

# nova™

Smart Tools, Powerful Solutions

## ORION 18" DVR LATHE™

OPERATION MANUAL



Publication: 128-0520-006

**Models:**

55250 – USA  
55251 – AUS/ NZ  
55252 – EU  
55253 – Canada  
55254 – UK

Date: 21 May 2020



# Contact

## Teknatool International Ltd

Phone: (+64) 9 477 5600

## Teknatool USA

Phone: 727-954-3433

## Customer Solutions

For all worldwide Inquiries, Repairs or Services (issues must be in writing)

Email: [Service@Teknatool.com](mailto:Service@Teknatool.com)

Or you can contact the retailer where you purchased your NOVA Orion 18" DVR Lathe, for the contact details please see our website [www.teknatool.com](http://www.teknatool.com)

# Table of Contents

Contact .....	2
Table of Contents .....	3
General Safety Rules.....	4
NOVA ORION 18" DVR FEATURES.....	5
Lathe Specifications .....	6
Package Contents .....	7
Assembling the Lathe .....	8
Connecting Lathe Bed Sections.....	8
Attaching the Lathe Bed to Stand.....	8
Attaching the Headstock onto the Bed.....	9
Locking the headstock into place.....	10
Attaching the Tool Rest onto the Bed.....	11
Attaching the Tailstock onto the Bed .....	11
NOVA ORION Bed Configuration .....	12
Connecting to Power .....	13
Ground Fault Interrupters (GFI).....	14
Input Voltage Selection.....	14
Setting Up Your Lathe .....	14
Workshop Environment.....	14
Lathe Interface .....	15
Keypad Buttons .....	15
Lathe Home Screen.....	15
Operating the Lathe.....	16
Starting Operation .....	16
Running the Lathe.....	16
Stopping the Lathe.....	17
Adjusting the Speed.....	18
Accessing the Main Menu.....	18
Favourite Speed Function.....	19
Using the lathe speed chart.....	21
Changing the Home Screen Display Mode.....	22
Switching between forward and reverse.....	23
Using the Lathe Spindle Lock.....	24
Swivelling the Headstock.....	25
Changing the <F> Key Functionalities .....	26
Wireless Remote.....	28
Password Lock .....	29
Lathe Settings .....	30
Maintaining Your Lathe .....	31
Maintenance after each use .....	31
Monthly maintenance .....	31
6-months Maintenance .....	31
Cleaning the Tool slide.....	31
Cleaning the Tailstock.....	31
Firmware Update.....	32
Checking the Firmware Version .....	32
USB Mode .....	32
Troubleshooting .....	33
Mechanical Issue .....	33
Electrical Issue .....	34
Teknatool Warranty.....	35
NOVA Orion Headstock Breakdown .....	36
NOVA Orion Tailstock Breakdown .....	36
NOVA Orion Toolrest Breakdown.....	37
NOVA Orion HMI Breakdown .....	37
NOVA Orion Bed and Stand .....	38
NOVA Orion Lathe Parts List.....	39

# General Safety Rules



**Failure to follow these rules may result in serious personal injury or death.**

❖ **IMPORTANT:** Before switching the lathe on, ALWAYS check the machine for the correct setting and speed

- 1. BEFORE OPERATING THE TOOL READ THE MANUAL!** Learn the machine's application and limitations, plus the specific hazards particular to it.
- 2. ALWAYS USE SAFETY GLASSES** (must be ANSI approved) Everyday eyeglasses usually are only impact resistant and safety glasses only protect eyes. A full-face shield will protect the eyes and face. Also use face or dust mask if sanding operation is dusty.
- 3. WEAR PROPER APPAREL.** Do not wear loose clothing, gloves, neckties, rings, bracelets or other jewelry which may get caught in moving parts. Nonslip footwear is recommended. Wear protective hair covering to contain long hair.
- 4. USE EAR PROTECTORS.** Use ear muffs for extended period of operation. Use muffs rated to 103 DBA LEQ (8 hour).
- 5. DO NOT USE IN DANGEROUS ENVIRONMENT.** Don't use power tools in damp or wet locations or expose them to rain. Keep work area well lighted. The NOVA ORION is intended for indoor use only. Failure to do so may void the warranty.
- 6. KEEP WORK AREA CLEAN.** Cluttered areas/benches invite accidents. Build-up of sawdust is a fire hazard.
- 7. KEEP CHILDREN AND VISITORS AWAY.** The NOVA ORION is **not recommended** for children and ailing persons. Such personnel and onlookers should be kept a safe distance from work area.
- 8. MAKE WORKSHOP CHILDPROOF** with locks, master switches, or by removing starter keys.
- 9. GROUND ALL TOOLS.** If the tool is equipped with a three-prong plug, it should be plugged into a three-hole electrical receptacle. If an adapter is used to accommodate a two-prong receptacle, the adapter plug must be attached to a known ground. Never remove the third prong and add surge protection.
- 10. MAKE SURE TOOL IS DISCONNECTED FROM POWER SOURCE** whilst in service/maintenance mode.
- 11. DISCONNECT TOOLS FROM WALL SOCKET** before servicing and when changing accessories such as bits, cutters, fuses, etc.
- 12. AVOID ACCIDENTAL STARTING.** Make sure switch is in the "Off" position before plugging in power cord.
- 13. NEVER LEAVE MACHINE RUNNING UNATTENDED.** Do not leave machine unless it is turned off and has come to a complete stop.
- 14. KEEP GUARDS IN PLACE** and in working order.
- 15. USE CORRECT TOOLS.** Do not use a tool or attachment to do a job for which it was not designed.
- 16. USE RECOMMENDED NOVA ACCESSORIES.** The use of improper accessories may cause hazards.
- 17. DO NOT FORCE THE TOOL.** It will do the job better and be safer at the rate for which it was designed.
- 18. MAINTAIN TOOLS IN TOP CONDITION.** Keep tools sharp and clean for best and safest performance. Follow instructions for lubricating and changing accessories.
- 19. NEVER STAND ON TOOL.** Serious injury could occur if the tool is tipped or if the cutting tool is accidentally contacted.
- 20. REMOVE ADJUSTING KEYS AND WRENCHES.** Form a habit of checking to see that keys and adjusting wrenches are removed from tool before turning it on.
- 21. DO NOT OVERREACH.** Keep proper footing and balance at all times.
- 22. DIRECTION OF FEED.** Mind the direction of spindle/chuck/work to ensure a safe environment.
- 23. PAY ATTENTION TO WORK.** Concentrate on your work. If you become tired or frustrated, leave it for a while and rest.
- 24. SECURE WORK.** Use clamps or a vice to hold work when practical. Severe injury or death can occur if an object comes free as it can become a dangerous projectile.
- 25. CHECK DAMAGED PARTS.** Before further use of the tool, any part that is damaged should be carefully checked to ensure that it will operate properly and perform its intended function. Check for alignment of moving parts, binding of moving parts, mounting, and any other conditions that may affect its operation. Any damaged part should be properly repaired or replaced.
- 26. DRUGS, ALCOHOL, MEDICATION.** Do not operate machine while under the influence of drugs, alcohol, or any medication.
- 27. DUST WARNING.** The dust generated by certain woods and wood products can be harmful to your health. Always operate machinery in well-ventilated areas and provide means for proper dust removal. Use wood dust collection systems whenever possible.
- 28. DO NOT MODIFY OR USE THE LATHE FOR USES OTHER THAN FOR WHICH IT WAS DESIGNED.**
- 29. CALIFORNIA PROPOSITION 65 – SEE PAGE 39**

# NOVA ORION 18" DVR FEATURES

Feature Name	Description	
<b>DIGITAL VARIABLE RELUCTANCE (DVR) ELECTRONIC DRIVE</b>	The DVR motor uses smart motor technology to provide an incredibly smooth and powerful drive. The controller constantly monitors the spindle position and maintains optimal spindle speed. Additional power is added as it senses extra load from the tool.	
<b>POWER TO TURN AND BURN</b>	1.75HP/110/ 2HP 220V Direct Drive DVR Motor.	
<b>ADD ON BED EXTENSION SYSTEM</b>	Each segment is 20"/510mmL	
<b>360° SWIVEL HEADSTOCK</b>	Lock at any position, plus detent locating positions at 0°, 22.5°, 45° and 90°. High accuracy and easy swivel	
<b>SOLID BED STRUCTURE</b>	CAD designed webbing to absorb vibration throughout the bed length. Exceptional structural strength.	
<b>8 FAVORITE SPEED FUNCTION</b>	Program your favorite speeds for faster and more efficient project set ups	
<b>FLEXIBLE CAPACITY TO MATCH YOUR PROJECT</b>	- 18"/457mm Capacity Over Bed - 29"/736mm Capacity Outboard (with optional outrigger accessory) - 45.25"/ 1149.35mm Between Centers	
<b>SAFETY SENSING FEATURE</b>	It senses faults in the setup and advises of safety issues- such as chisel dig in and spindle lock. It then instantly shuts down power to the spindle.	
<b>ENERGY EFFICIENT</b>	Intelligent (computer controlled) motor only draws as much power as it needs for the application	
<b>INCREDIBLE VARIABLE SPEED RANGE</b>	100 RPM - 5,000 RPM	
<b>WARRANTY</b>	* 5 Year Warranty on Parts and Components *2 Year Warranty on Motor and Electronics * <i>Restrictions apply</i>	

# Lathe Specifications

	Metric	Imperial
<b>Swing Over Bed</b>	457.2mm	18"
<b>Distance Between Centres</b>	560mm / 1120mm	22" / 44"
<b>Overall Size</b>	1800mm (L) x 600mm (w) x 1240mm(H)	44.5 (L) x 23.5" (w) x 48.82" (H)
<b>Weight</b>	210 Kg	460 lb
<b>Headstock</b>		
<b>Spindle Thread</b>	M33 x 3.5 RH*	1.25" x 8TPI
<b>Headstock Spindle Taper</b>	Morse Taper #2 (MT2)	
<b>Headstock Swivel</b>	360° With detent positions at: -45°, 0°, 22.5°, 45°, 90°, 180°	
<b>Spindle Index</b>	24 divisions (15 degrees apart)	
<b>Tailstock</b>		
<b>Quill Taper</b>	Morse Taper #2 (MT2)	
<b>Quill Travel</b>	80mm	3"
<b>Hole Through Tailstock</b>	12.5mm	0.48"
<b>Tool Rest</b>		
<b>Length</b>	300mm	12"
<b>Shaft Diameter</b>	25.4mm	1"
<b>Motor Specifications</b>		
<b>Motor Type</b>	DVR Direct Drive Smart Motor	
<b>Motor Speed Range</b>	100 RPM ~ 5000 RPM	
<b>Input Frequency</b>	50/60 Hz	
<b>Motor Power Output</b>	1.3KW (1.75HP)	1.5KW (2HP)
<b>Input Voltage</b>	110~120V	220~240V
<b>Input Current</b>	15A (max)	10A (max)

\*M33 x 3.5 RH thread spindle only available in European model. All other market models will have the 1.25inch x 8 TPI spindle.

# Package Contents

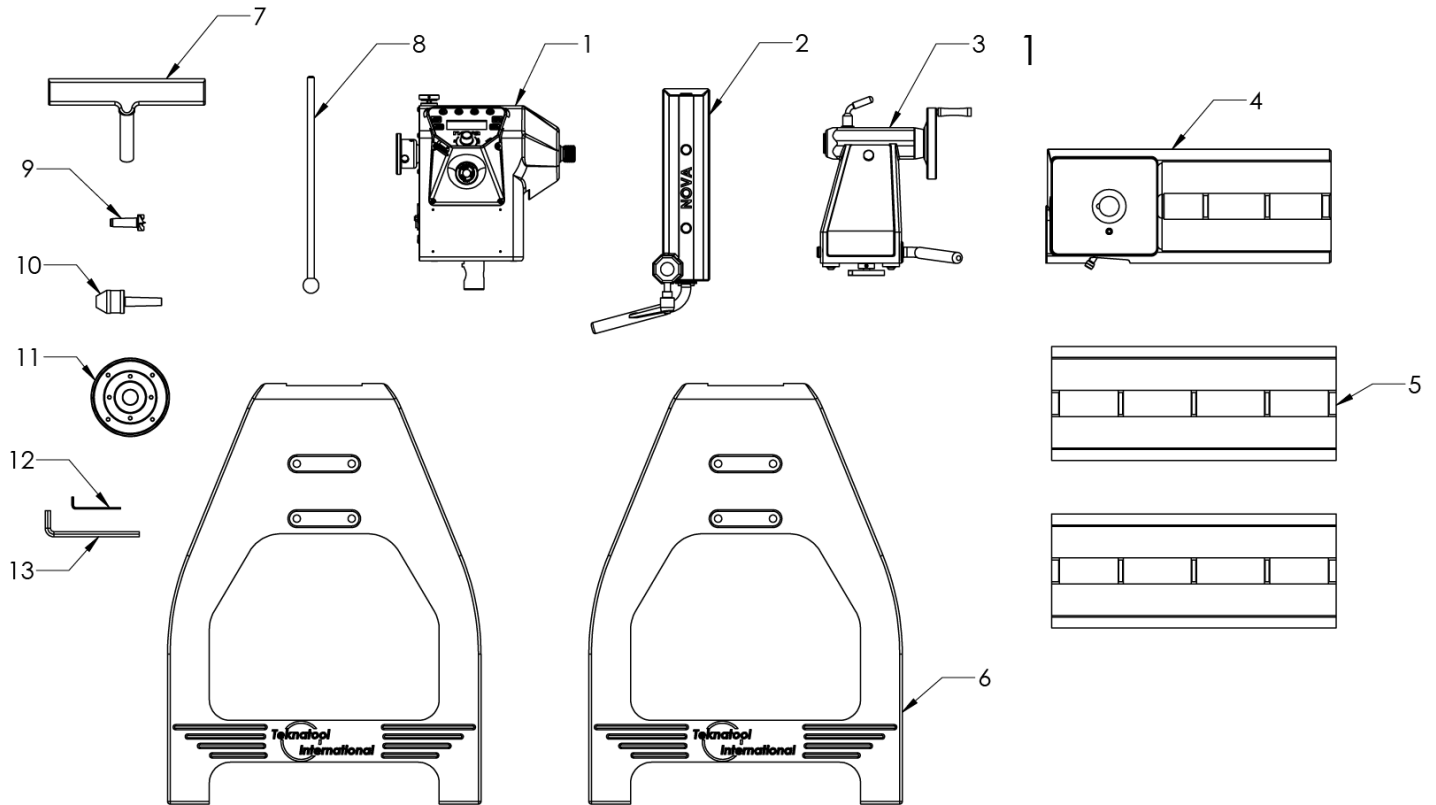

ITEM NUMBERS	DESCRIPTION	SKU
1	Headstock Assembly (+HMI)	5699001 + 5699005
2	Tool Slide Assembly	5699004
3	Tailstock Assembly	5699033
4	Main Bed	5699021
5	Bed Extension*	5699035
6	Lathe stand	5699018
7	12" (300mm) Tool Rest	5699024
8	Knockout/Operating Bar	5699033
9	2MT Spur Centre	2MTSPUR
10	2MT Live Centre	5020
11	6" (150mm) Face Plate	FP150L
12	3mm Allen Key	AK3
13	10mm Allen Key	AK10

**Note:** Only US model includes the second bed extension. All other market models will include one bed extension unit.

# Assembling the Lathe

## Connecting Lathe Bed Sections

Place the lathe bed onto a leveled surface with a 24mm thick block of wood or anything similar.

Connect the main bed assembly and extension bed section together but using the bolts

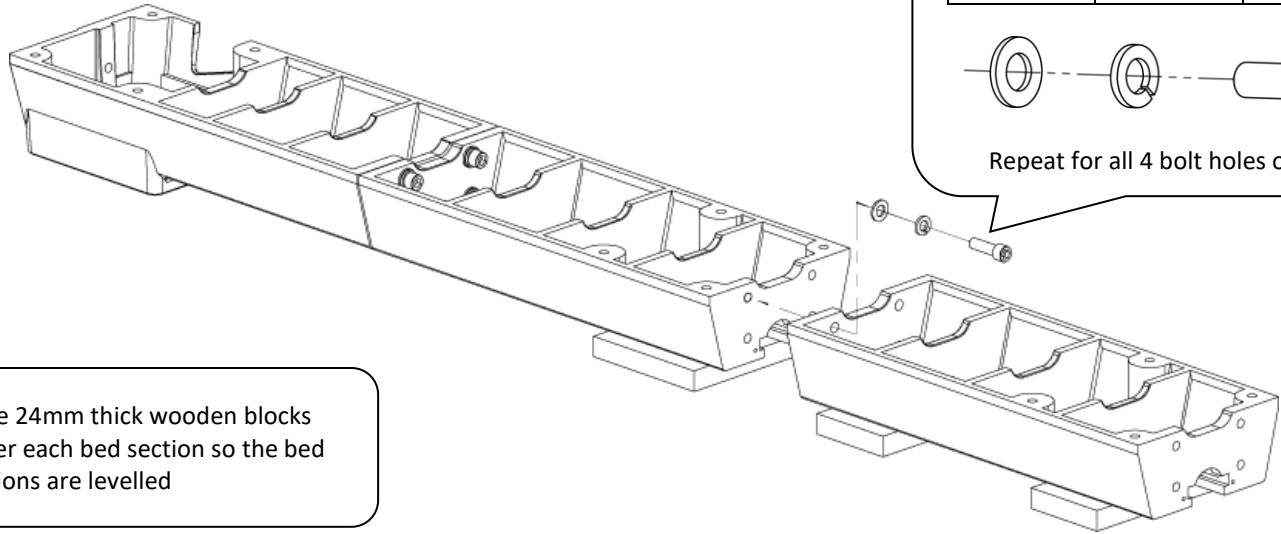

### ASSEMBLY NOTE

Washer	Spring Washer	Bolt
--------	---------------	------

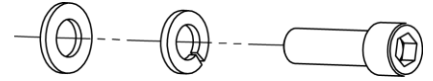

Repeat for all 4 bolt holes on bed

Place 24mm thick wooden blocks under each bed section so the bed sections are levelled

Make sure to use the washers included in the package to prevent damage to the lathe bed sections.

### Note:

This step is only for people who would like a longer bed section on the lathe (44inch between centers). If 24 inches between center is desired, this step can be disregarded. Bed extension included as standard only in the US model (55250), bed extension is sold separately in all other markets.

## Attaching the Lathe Bed to Stand

**SAFETY CAUTION:** Each of the lathe stand legs have a significant mass (Approximately 35Kg) therefore 2~3 people will be needed for assembly.

Place one of the lathes' stand leg on top of the lathe bed turned upside down.

Use 4 bolts to secure the stand leg onto the lathe bed.

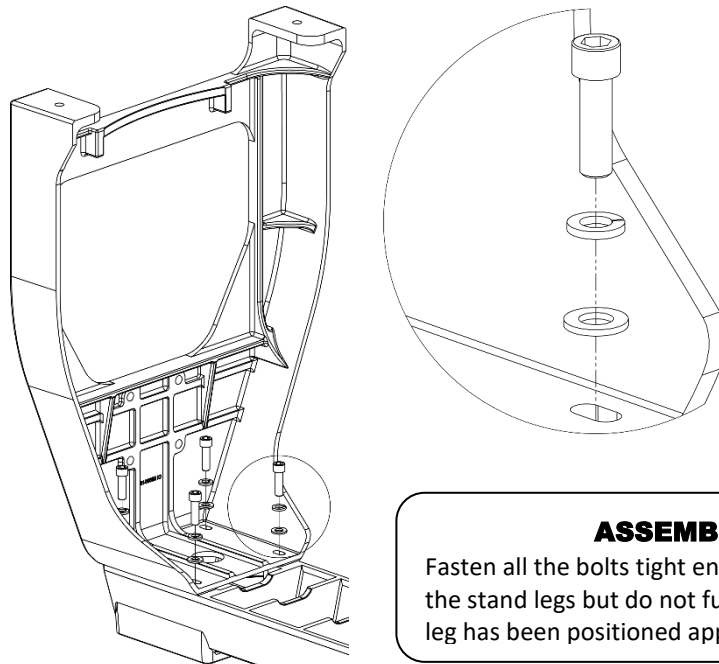

### ASSEMBLY NOTE

Fasten all the bolts tight enough so it barely touches the stand legs but do not fully tighten until the stand leg has been positioned appropriately.



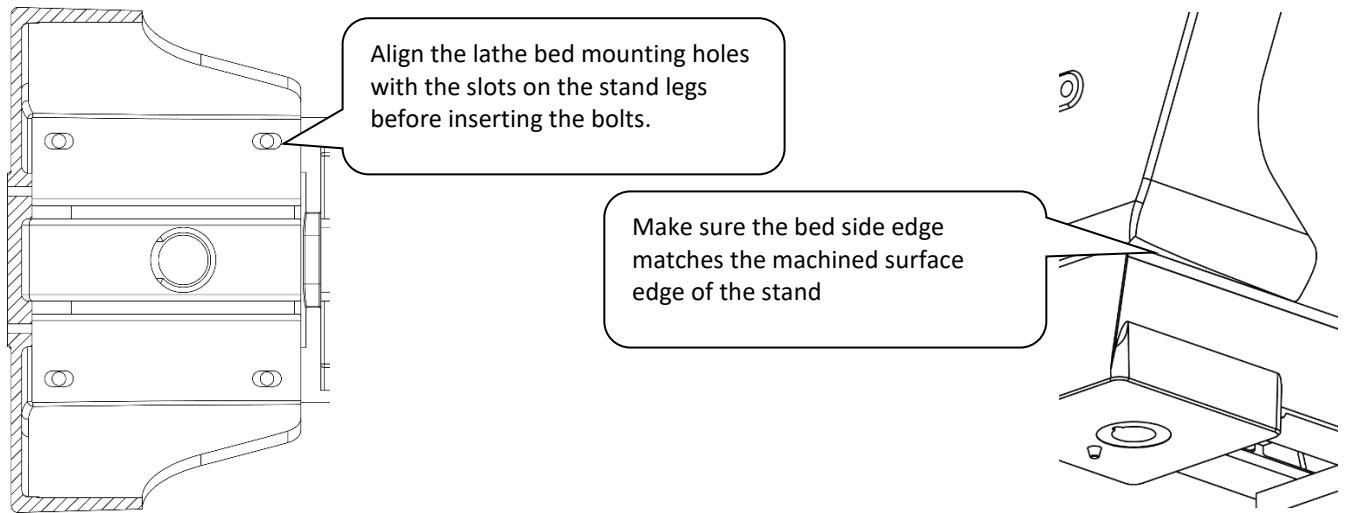

## Attaching the Headstock onto the Bed

**⚠ SAFETY CAUTION:** The headstock unit itself has a significant mass (Approximately 50Kg) therefore extreme caution must be taken to lift the headstock up to a height where it can be attached to the bed.

Insert the centre pin of the headstock into the bore of the lathe bed to mount the headstock.

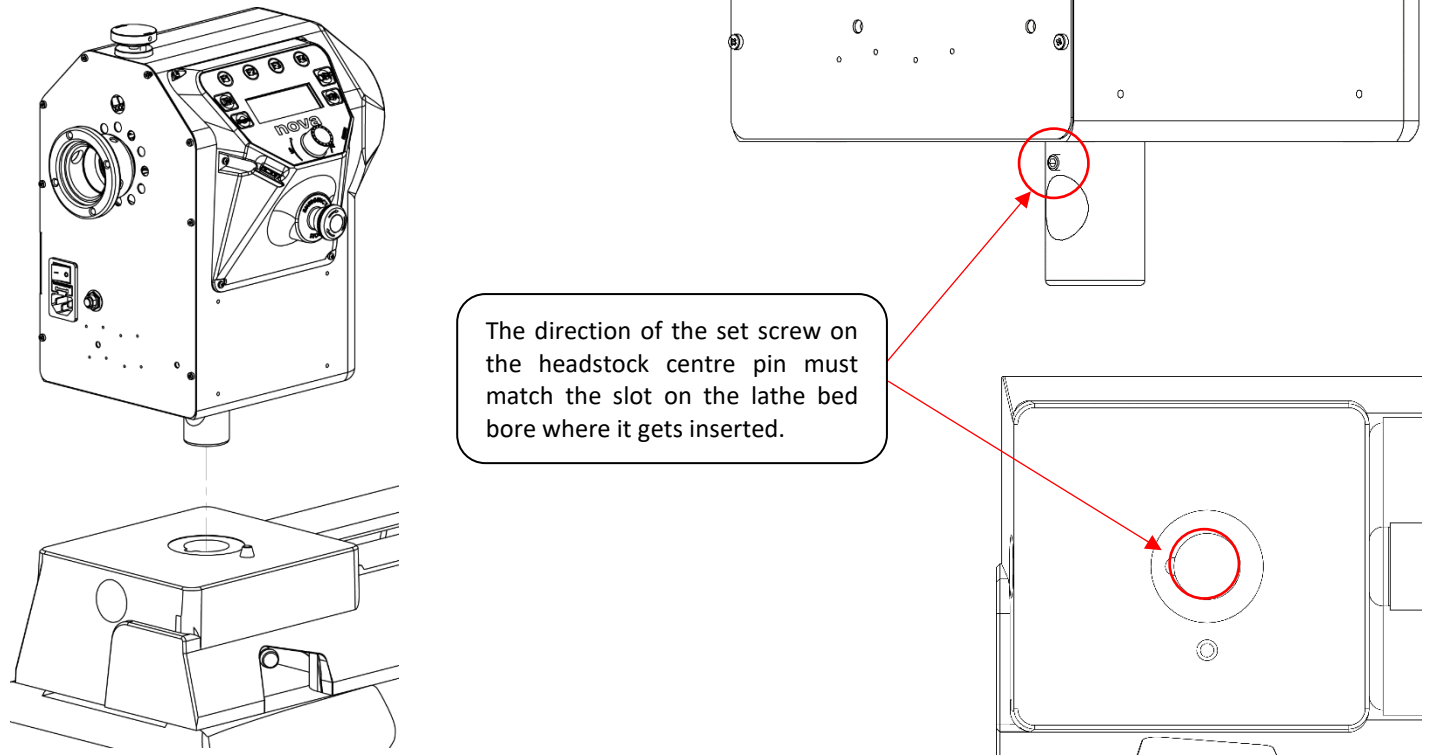

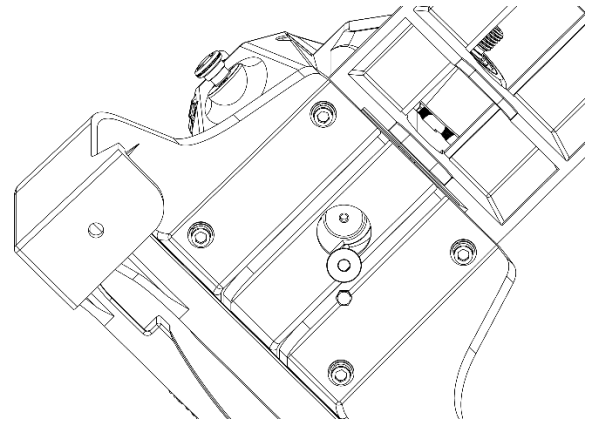
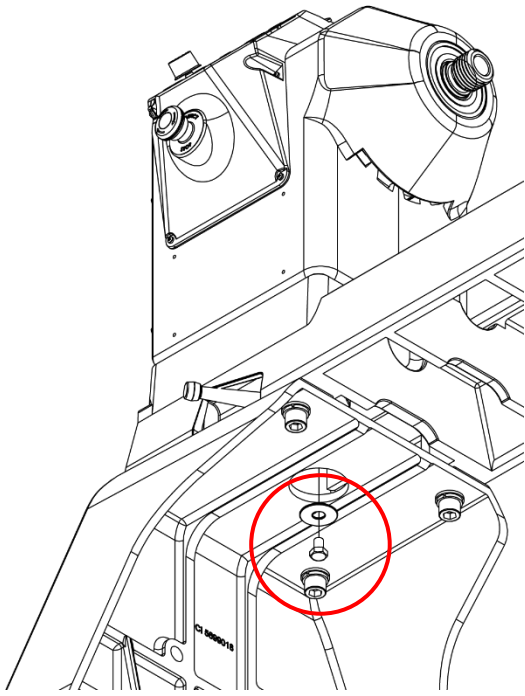

Secure the headstock onto the lathe bed by using the 8mm flat wide washer and M8 hex head bolt included in the packaging.

Insert the bolt and washer from underneath the stand through the hole and thread the bolt onto the headstock centre pin.

➤ **Note:** A hex socket extension may be needed to tighten this bolt.

### Locking the headstock into place

The headstock is locked into place by the headstock locking pin.

1.

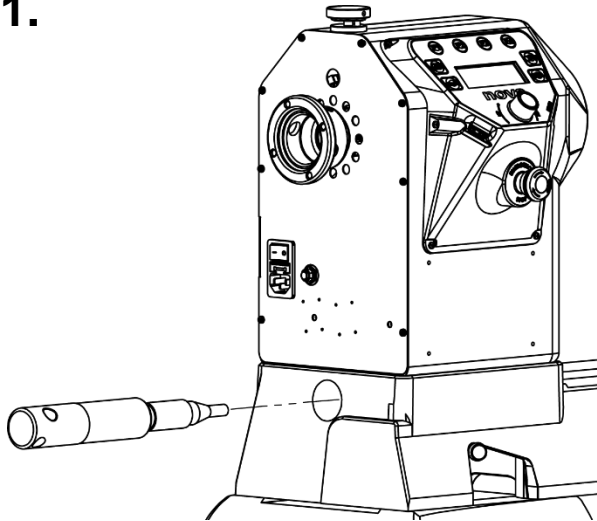

Insert the headstock lock pin into the bore on the lathe bed as shown in the above image.

Hand tighten until it becomes firm

2.

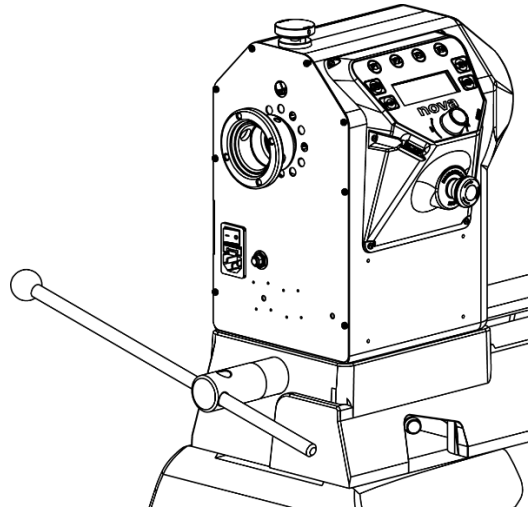

Further tighten the headstock lock pin by using the operating bar until firm to ensure the headstock is locked in place.

**⚠ WARNING! ⚠**

Do not over tighten as it may cause damage to the lathe bed.

## Attaching the Tool Rest onto the Bed

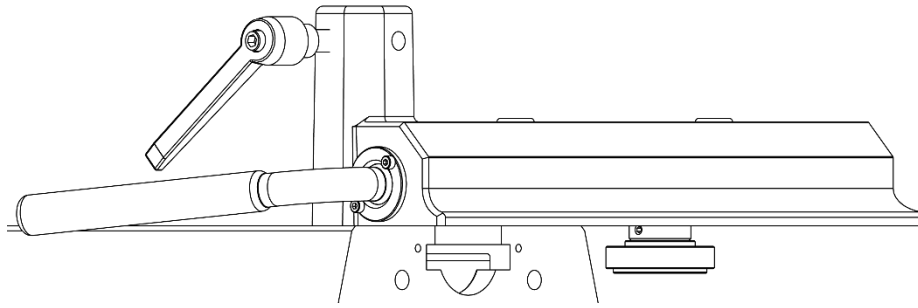

Slide the tool rest assembly onto the bed by matching the tool slide lock plate with the cut out made on the side of the lathe bed sections.

➤ **Note:** Turn the handle to adjust the position of the tool slide lock plate if it cannot slide onto the lathe bed section.

Attaching the tool rest onto the tool slide

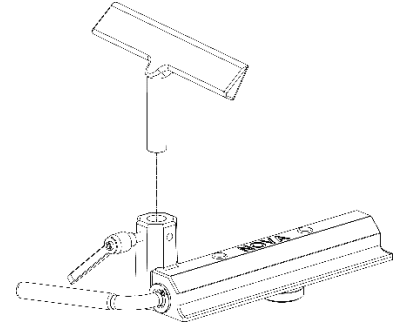

Loosen the tool rest lock handle and ensure nothing is inside the tool slide bore.

Insert the tool rest into the tool slide bore and tighten the tool rest lock handle to secure its position.

## Attaching the Tailstock onto the Bed

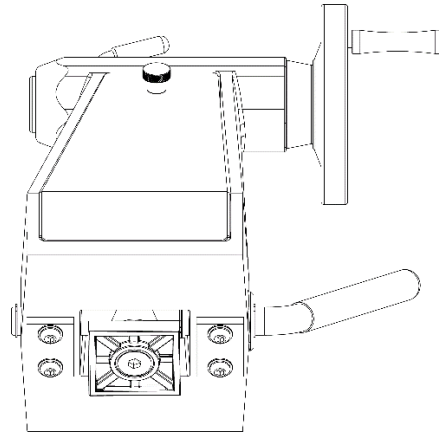
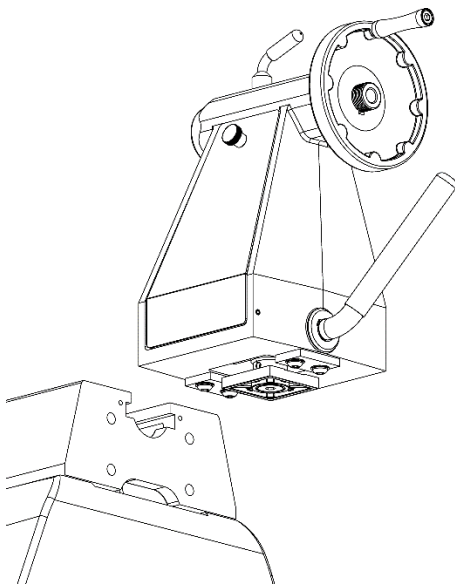

Slide the tailstock assembly onto the lathe bed section by matching the tailstock lock plate with the cut out made of the side of the lathe bed sections.

➤ **Note:** Turn the tailstock lock handle to adjust the position of the tailstock lock plate if the tailstock cannot slide onto the lathe bed section.

Attach any known straight sharp pointed tool (E.g. Spur and live centres) on the headstock spindle and tailstock quill to check for axial alignment between headstock and tailstock.

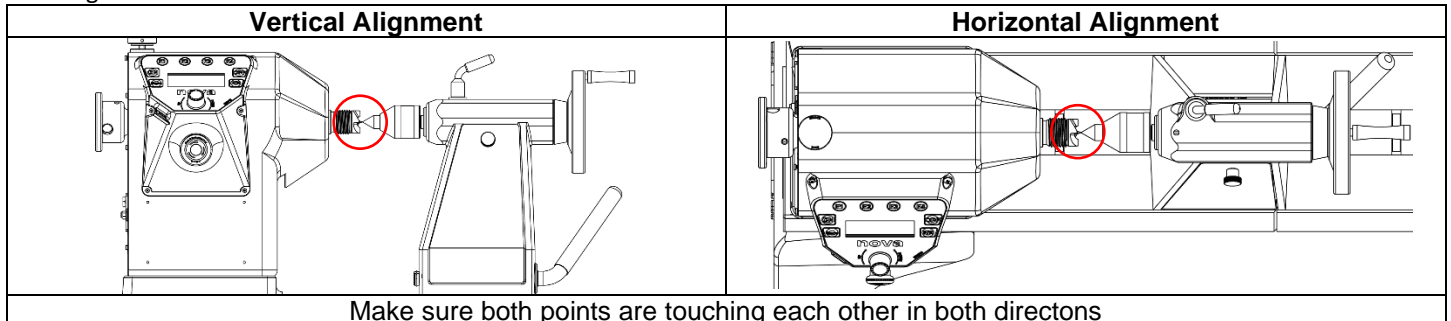

# NOVA ORION Bed Configuration

Multiple configurations to suit unique size needs

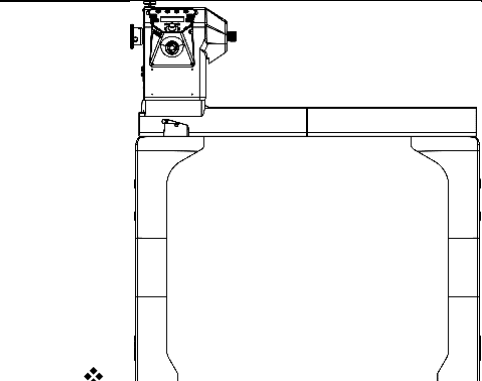
Basic Configuration	
	
Center to Center Distance	
Metric	Imperial
558.8mm	22"

**EU/World Standard**  
 Bed Accessory Extension (5699035)  
 Available for additional purchase

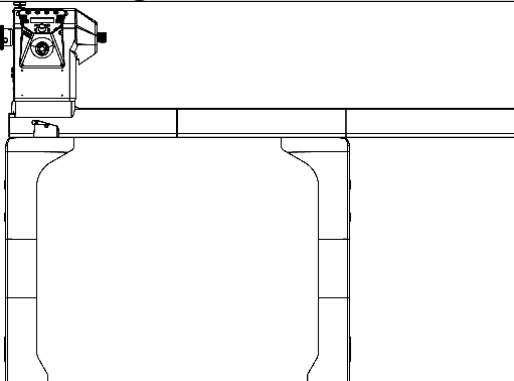
Basic Configuration with Bed Extension	
	
Center to Center Distance	
Metric	Imperial
1117.6mm	44"

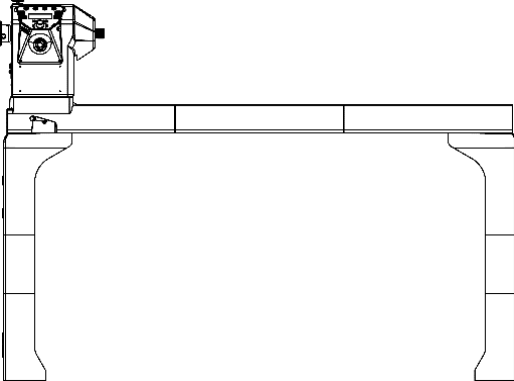
3-Bed Configuration	
	
Center to Center Distance	
Metric	Imperial
1117.6mm	44"

**U.S. Standard**  
 3-Beds

# Connecting to Power



## Warning!



Improper power connection may result in a risk of electrical hazard.

Before plugging the NOVA Orion lathe into the power source:

1. The main power switch is turned off
2. Power source is switched off

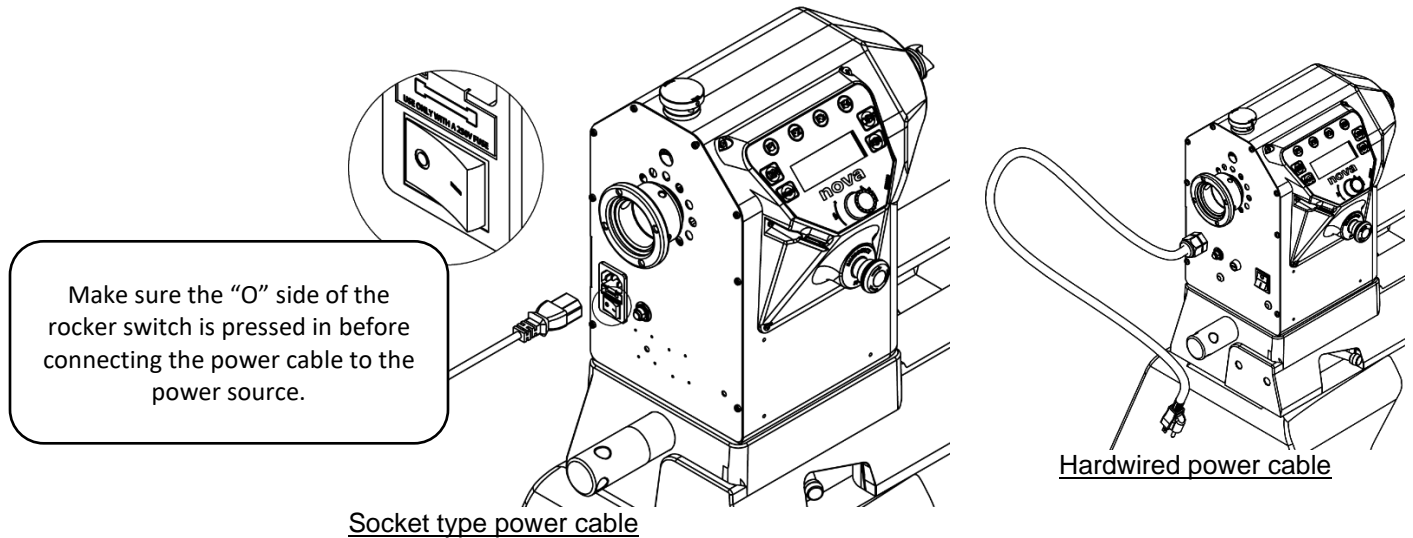

**Note:** This image on the left-hand side is the European version of the NOVA Orion wood lathe. Other versions will have a hard-wired power cable (shown on the image on the right-hand side)

The power cord that is installed on the NOVA Orion lathe will have a three-prong plug which includes a ground prong. The plug must be connected to a matching outlet that his properly installed and grounded in accordance with local electrical codes.

### **For 115V Outlet Only:**

A temporary adapter can be used to plug into a two-pole outlet if a three-prong outlet is unavailable in your environment. The ground tab on the adapter must be connected to the screw on the outlet for proper grounding. This adaptor should only be used until a qualified electrician can install a properly grounded outlet.

- **Note:** *If an extension cable is required, make sure to check the following:*
1. Extension cable gauge
  2. Is the cable properly insulated?

If in any doubt, please contact your local electrician to inspect the cord according to the local electrical standards before using it.

### **❖ IMPORTANT:**

- A surge protection device must be used when using the lathe.
- A surge protection device must be rated to at least 15A should be used in countries where 115V are used as a standard. In countries where 240V is used, a surge protector must be rated to either 10A or 15A.

## Ground Fault Interrupters (GFI)

For a GFI to be compatible with the DVR motor, it must have a **leak current threshold rating of 30mA (0.03A)**

- **Note:** Normal household GFI will typically be rated at 5mA (0.005A) which may trigger during the operation of the DVR motor. However, frequent tripping of the GFI will not cause any harm to the DVR motor or its control electronics as it has a built-in protective circuit to prevent damage from frequent switching.

## Input Voltage Selection

The NOVA Orion lathe is capable of handling both 115V and 240V without any changes to its internal circuits.

The lathe will automatically recognize the input voltage to the lathe and adjust the output power. Simply change the input power plug to a suitable plug for the desired input voltage to change the lathe's input voltage.

i.e. For US:



For 115V



For 240V (NEMA 6-15P)

For regions where 240V is standard:



Europe



Australia/ New Zealand

## Setting Up Your Lathe Workshop Environment

Your workshop should set up appropriately for you to effectively use the lathe. The workshop should be setup with the following factors taken into consideration:

### 1. Lathe location

Locate the NOVA Orion lathe close to a power source in an area with good amount of lighting. Leave enough clearance when the lathe headstock is swivelled around. Other machines in the workshop should not interfere with the movement/operation of the lathe.

### 2. Lighting

The work shop should have adequate lighting. There should be enough lighting around the lathe not to cast shadows upon the workpiece. If possible, locate the lathe near a window. A portable spotlight might be helpful.

### 3. Electrical

The NOVA Orion lathe requires an appropriate power outlet nearby to power the motor. The outlet wiring must meet the local electrical safety standards. If in any doubt, seek advice from an electrician. The length of an extension cable should be reduced as much as possible.

### 4. Ventilation

Workshop must have an adequate level of ventilation. The level of required ventilation depends on the size of the workshop and the amount of work that is done within the workshop. The use of dust collectors and filters will minimize your health risk.

## Lathe Interface

### Keypad Buttons

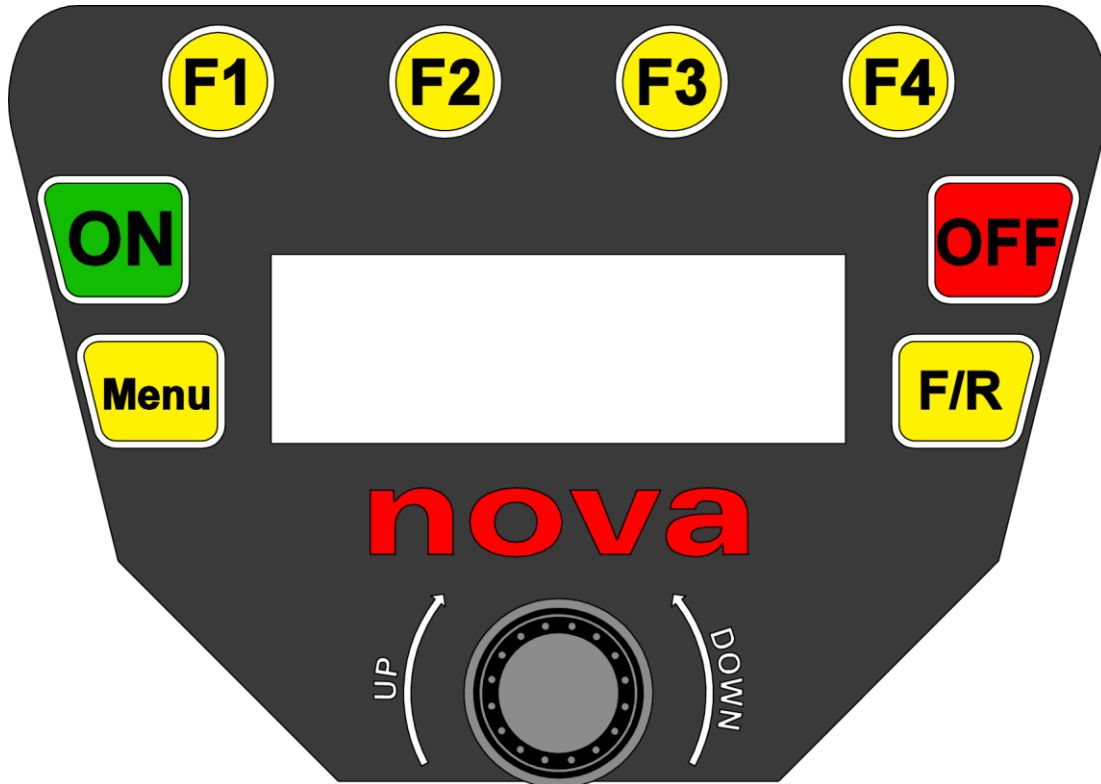

### Lathe Home Screen

There are 2 home screen display modes available for the NOVA Orion lathe

```
500 >>
      rpm
Ready to run
```

**LARGE NUMBER DISPLAY**

```
250 500 750 1020
Set Spd: 500rpm >>
Ready to run
```

**NORMAL NUMBER DISPLAY**

The large number display will display:

- Set RPM of the lathe (When the motor is not turned on). This will change to the actual RPM of the lathe spindle when the motor is turned on.

The normal number display will display:

- Favourite speed assigned to each of the <F> keys.
- From the right, the favourite speeds are assigned to: <F1>, <F2>, <F3>, <F4>

- Forward and reverse state
- Current state of the lathe

- The second set of favourite speeds will not be displayed.
- When the motor is off, set RPM of the lathe. This will change to the actual RPM of the lathe spindle when the motor is turned on.
- Forward and reverse state
- Current state of the lathe

## Operating the Lathe

### Starting Operation

When the main power switch has been turned ON, the LCD screen on the HMI will display the texts shown below:

```
Refer to owners
manual for safe
operating procedure.
Ensure proper speed
```

```
and direction are
selected.
Always use guards
and eye protection.
```

Additionally, the following screen will be shown at the end of the starting sequence if the braking function is enabled on the lathe. This message can be cleared to proceed on the lathe home screen by pressing any key on the HMI. The home screen will be shown once the starting sequence is completed.

```
==BRAKING ENABLED!==
Ensure Set Screws
are TIGHTLY SECURED
to Prevent Unwinding
```

### Running the Lathe

Press the <ON> key while on the home screen to start the motor.

The motor will accelerate to its set speed and keep its set speed.





## Stopping the Lathe

Press the <OFF> key while on the home screen to stop the motor.

The motor 2 types of behaviours when the <OFF> key is pressed:

- Motor stops and no brakes applied
- Motor stops and brakes are applied



## Emergency Stop Switch

The emergency stop switch can be pressed to stop the motor any time during operation. Brakes will be applied when the emergency stop switch is pressed.

Once the emergency stop switch is pressed, the motor will not start until the switch is released by twisting it in the clockwise direction.



## Adjusting the Speed

Set speed of the lathe motor can be adjusted anytime while the HMI is on the home screen.

The set speed can be adjusted by turning the speed adjustment knob.

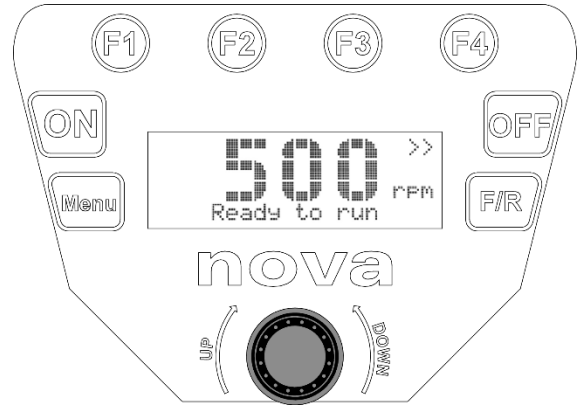

## Input Set Speed Function

The input set speed function allows to quickly set the lathe to any speed within 5rpm by using the function <F#> keys

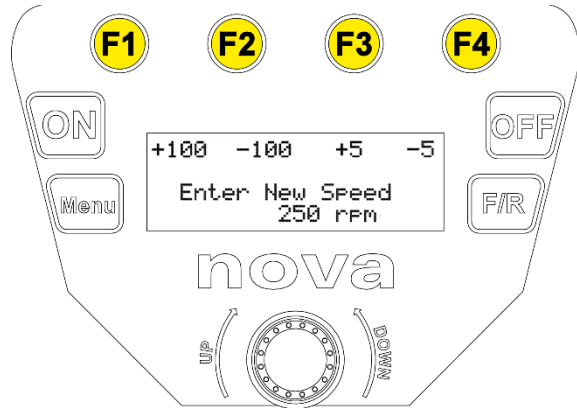

## Accessing the Main Menu

The main menu is used to access all available software features on the lathe.

Press <Menu> key while on the home screen to access the main menu of the lathe.

The screen will switch to the main menu once the key is pressed. =]=[]=[p-]=[p--

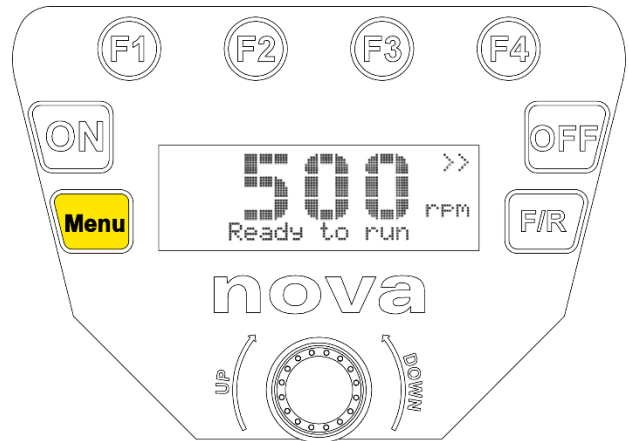

## Main Menu Contents

The following are the contents of the main menu in the NOVA Orion lathe:

1. Speed Chart
2. Input Set Speed
3. Edit Fav Speed #1-8
4. Profile: <Selected profile>

```
► Speed Chart →  
Input Set Speed →  
Edit Fav Spd #1-8 →  
Profile: Normal
```

5. Customize F Keys
6. Lathe Settings
7. Wireless remote
8. Motor Parameters
9. Password Lock
10. Firmware Upgrade
11. Version Info

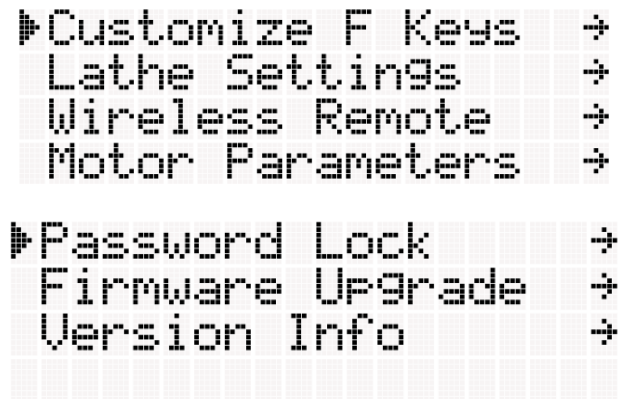

Each function in the menu will be described in detail in the later section of this manual.

## Favourite Speed Function

Favourite speed function allocates pre-set speed to each of the function keys (<F> keys) so the most commonly used lathe speeds can be accessed without using speed dial knob.

A total of 2 speeds can be set to a single <F> key (i.e. A total of 8 speeds can be set to the favourite speed function).

## Setting Favourite Speed Function

- **Note:** The <F> keys must be set to use the favourite speed function to have access to all assigned speeds. Refer to [page27](#) to check the alternative functions that can be assigned to the <F> keys.

While on the home screen, press one of the <F> keys where the desired speed is assigned to.

Press the <F> key once to access the first assigned speed  
 Press the <F> key again to switch between the first assigned speed and the second assigned speed.

The default speeds for the favourite speed function are the following:

Allocated Keys	Favourite speed Number	Default Allocated Speed
F1	#1	250
	#2D (Default)	500
F2	#3	750
	#4	1020
F3	#5	1250
	#6	1500
F4	#7	1750
	#8	2000

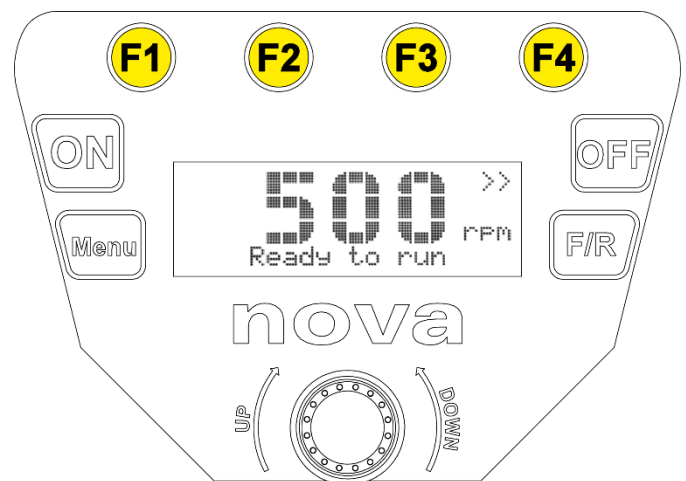

After pressing one of the <F> key to change the lathe speed, the lathe screen will change a screen where it asks for conformation to change the lathe set speed.

Press<F/R> key to confirm and change the lathe to the speed allocated to the favourite speed.

Press <Menu> key to cancel setting the speed from favourite speed and return to the home screen.

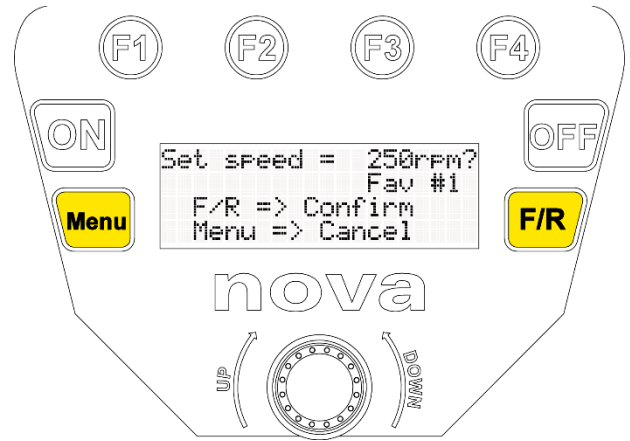

## Editing the Favourite Speed Function

Press the <Menu> key while on the lathe home screen to access the main menu of the lathe.

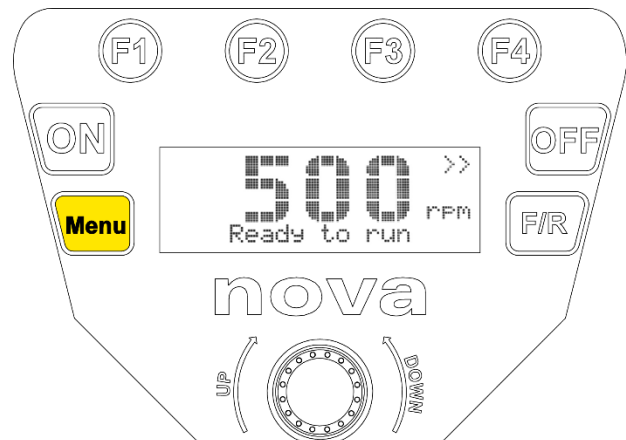

Navigate down the “Edit Fav Speed #1” item on the menu.

Press in the speed control knob to enter the function.

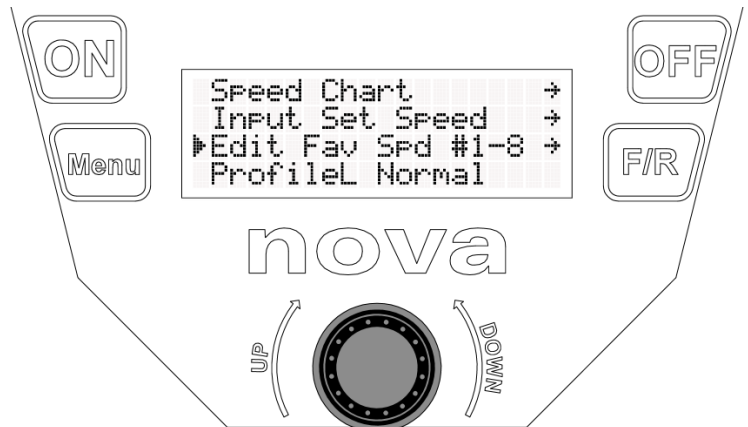

Use the speed control knob to navigate down to the favourite speed to edit.

> **Note:** There are 2 pages to this screen. The pages will automatically switch when scrolled down.

Press the speed control knob when the cursor is next to the favourite speed to edit.

Fav #1	:	250	rpm
▶ Fav #2	:	500	rpm
Fav #3	:	750	rpm
Fav #4	:	1000	rpm

After pressing the speed control knob on the selected favourite speed, the screen will change to enter the new lathe speed to assign.

Both <F> key and speed control knobs can be used to adjust the new speed value.

Key	Effect
F1	+100rpm
F2	-100rpm
F3	+5rpm
F4	-5rpm

Press the speed control knob to set the new favourite speed value.

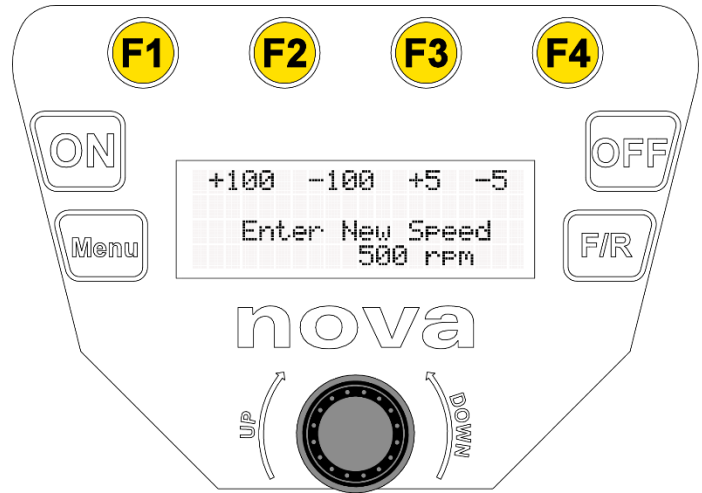

### Using the lathe speed chart

Access the speed chart function from the menu by pressing the <Menu> key on the lathe home screen.

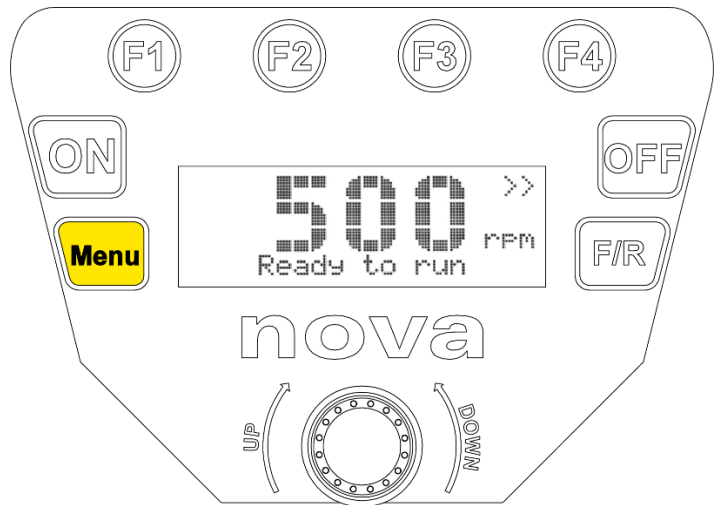

“Speed Chart” will be the first option that will appear on the lathe menu screen.

Press in the speed control knob to enter the speed chart function.

Use the speed control knob to select the desired type of cut; Finishing/ Shaping cut or Rough cut.

Press in the speed control knob to enter the selected menu of the selected type of cut.

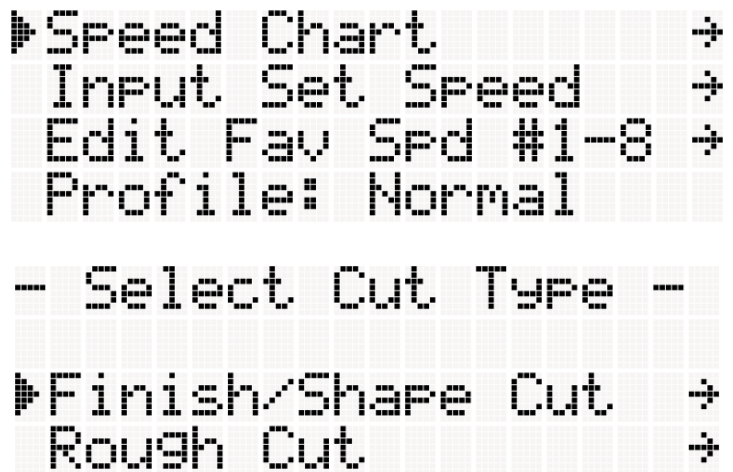

The lathe will prompt to select the approximate diameter of the workpiece. The lathe will automatically suggest the recommended speed for the operation.



➤ **Note:** The speed shown on the lathe is only a recommendation/ guideline. Actual required lathe speed must be determined from the actual condition along with the experience of the turner.

### Changing the Home Screen Display Mode

Press the <Menu> key while on the lathe home screen to access the main menu of the lathe.

#### To Customize F Keys, go to:

- Lathe Settings
- Wireless Remote
- Motor Paramters
- Customize F keys
- Lathe Settings
- Wireless Remote
- Motor Paramters

Use the speed control knob to navigate down to “Lathe Settings”.



Press the speed control knob to enter the function.

The first option “Display Size” will indicate the current display mode the lathe home screen is set; Large or Normal.

Press in the speed control knob while the cursor is next to the line “Display Size”. The display mode will switch between “Large” and “Normal”

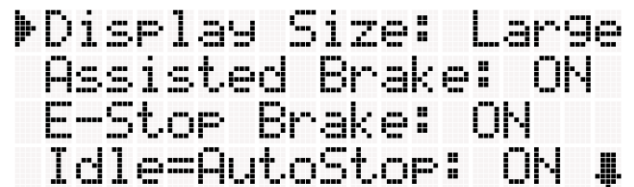

Press <OFF> to return to the home screen once the desired home screen display mode has been selected.

➤ **Note:** The change will take effect immediately.

## Switching between forward and reverse

While on the lathe home screen, press <F/R> key to switch between forward and reverse.

➤ **Note:** The lathe motor must be turned off in order to switch between forward and reverse. Forward and reverse cannot be switched while the lathe motor is running.

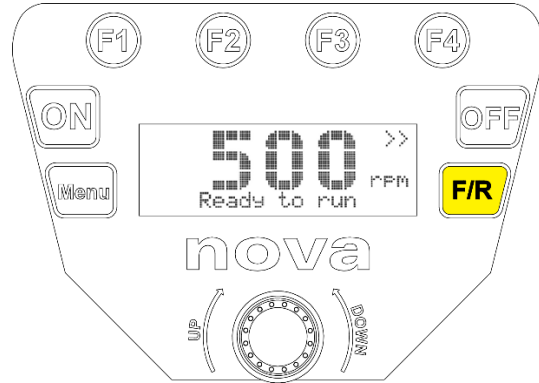

The Forward and reverse mode of the lathe is indicated by the arrow displayed on the top right-hand corner of the LCD screen.

Large home display	Normal number display
<p>500 &gt;&gt; rpm Ready to run <b>Forward Mode</b></p>	<p>250 500 750 1020 Set Spd: 500rpm &gt;&gt; Ready to run <b>Forward Mode</b></p>
<p>500 &lt;&lt; rpm Ready to run <b>Reverse Mode</b></p>	<p>250 500 750 1020 Set Spd: 500rpm &lt;&lt; Ready to run <b>Reverse Mode</b></p>

## Using the Lathe Spindle Lock

The NOVA Orion lathe features 24 spindle indexing position which can also be used as a lock spindle lock.

### Engaging/Disengaging the Spindle Lock

Pull the spindle index pin out from the headstock and turn it 180 degrees so the “Lock” text is closer to the HMI.

Slowly release the spindle index pin to let the spring pull the index pin into the headstock.

Turn the lathe spindle by hand to ensure the spindle lock has engaged properly.

- **Note:** Head of the index pin will be completely flat against its housing when the spindle lock is engaged properly.

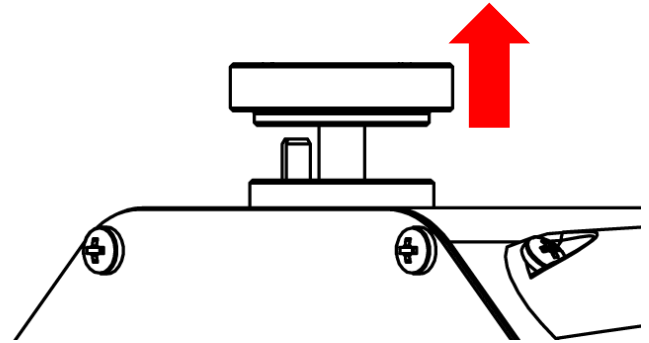

Pull the spindle index pin out from the headstock and turn it 180 degrees so the “Unlock” text is closer to the HM to disengage the spindle lock.

- **Note:** Head of the index pin should be held up by the tension pin of the index pin housing.

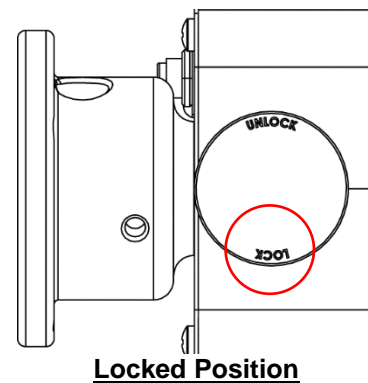

**Locked Position**

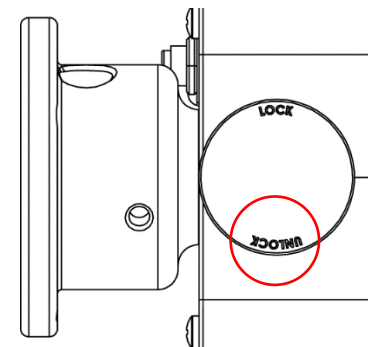

**Unlocked Position**



## Swivelling the Headstock

Loosen the headstock lock pin to free headstock.

- **Note:** Use the operating bar to provide more leverage then loosening the headstock lock pin as it can become tighter over time.

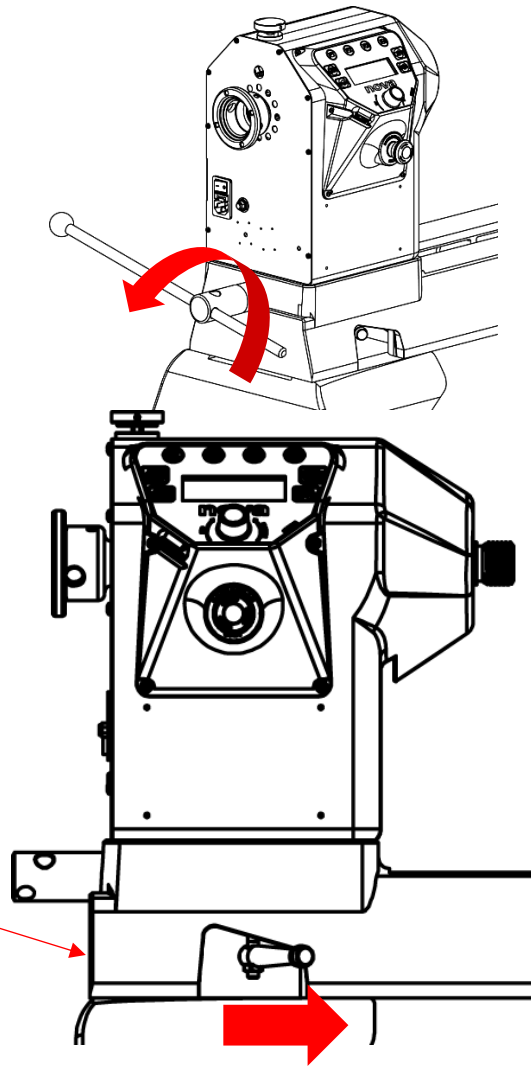

Push the detent lever towards the right-hand side and hold it in position.

Turn the headstock to the desired position.

NOVA Orion lathe has the headstock locking positions at the following angles:

Positive	Negative
22.5°	-45
45°	
90°	
180°	

Push the detent lever back to the left-hand side once the headstock is approximately in the desired position. Turn the headstock left and right to ensure the detent pin is properly engaged with the headstock.

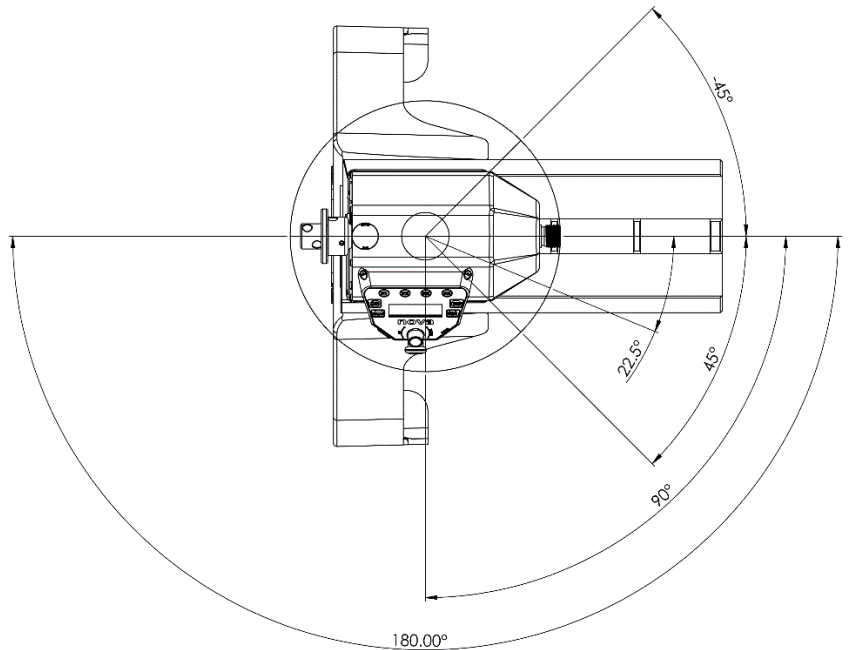

Retighten the headstock locking pin to ensure the headstock is securely locked.

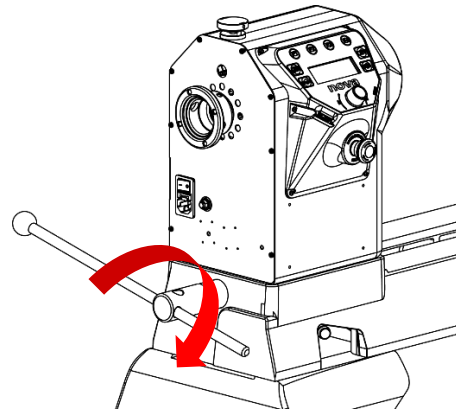

## Changing the <F> Key Functionalities

Press the <Menu> key to enter the lathe main menu of the lathe

Navigate down to “Customize F keys” on the second page using the speed dial.

Press in the speed dial to enter the function.

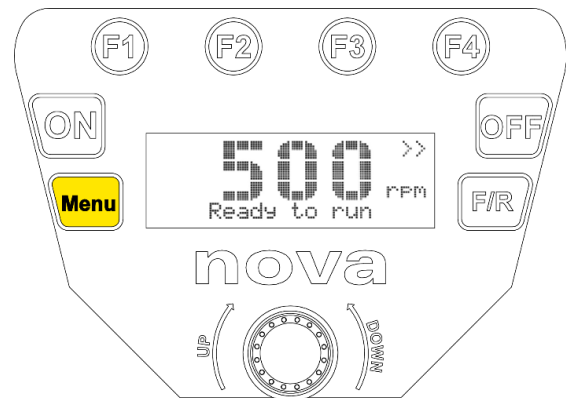

```
▶Customize F keys →  
Lathe Settings →  
Wireless Remote →  
Motor Parameters →
```

The menu screen will show the current functionality assigned to the F keys (Favourite speed at default).

Following functionalities can be assigned to the F keys

1. Favourite Speed (Displayed as: Fav Speed)
2. Speed Up/ Down
3. User Custom

Press the speed knob when the cursor on the left-hand side is in line with “F1-4 Function:” text to cycle through the above options.

```
▶F1-4 Function:  
Fav Speed  
Edit User Custom  
F Key Settings
```

Press the <OFF> key Once the desired function is set to return to the home screen. The change will immediately take effect.

## User Custom Settings

Functions other than Favourite Speed and Speed Up/ Down can be assigned to the F keys through “User Custom” settings.

Press the speed knob when the cursor on the left-hand side is in line with “**Edit User Custom**” text to enter the function assignment screen.

The function assignment screen will display the current function assigned to each of the F keys.

➤ **Note:** On User Custom, Functions can be assigned to each individual F key.

Using the speed dial to navigate the cursor in line with the F key where you would like to assign the function. Press the speed dial knob to enter the function selection page.

```
F1-4 Function:
User Custom
▶Edit User Custom
F Key Settings
```

```
▶F1: Fav Speed #1
F2: Fav Speed #2
F3: Set Speed +20
F4: Set Speed -20
```

```
- F1 Key Function -
▶Do Not Use
Fav Speeds →
Speed Up/Down →
```

### FUNCTION ASSIGNMENT PAGE

The following table shows the functions that can be assigned to the F keys:

FUNCTION NAME	DESCRIPTION
<b>Do Not Use</b>	This will disable the selected <F> key
<b>Favourite speed</b>	Any Favourite speed can be set on any of the F keys. e.g. Favourite Speed #8 can be assigned to <F1> key
<b>Speed Up/ Down</b>	When this function is assigned to the <F> key, the selected <F> key can be used to either increase or decrease the speed in the following increments: 1. 5rpm 2. 20rpm 3. 100rpm 4. 250rpm 5. 500rpm
<b>Speed Profile</b>	The speed control profile can be selected from the following: <ul style="list-style-type: none"> <li>• Low</li> <li>• Medium</li> <li>• High</li> </ul> Speed profile will determine the acceleration of the motor. E.g. Higher acceleration with the High-speed profile.
<b>Brakes On/ Off</b>	Switching between ON state and OFF state of the electronic brakes.
<b>Menu Shortcuts</b>	This will assign a shortcut to the selected <F> key

## Wireless Remote

The standard NOVA DVR Wireless Remote II (SKU 55522) can be used with the NOVA Orion lathe (Refer to Appendix XX for installation procedures).

Once the remote receiver is installed on the lathe:

- Navigate down to “Wireless Remote” function in the lathe main menu.
- Press the speed knob to enter the function.

```
Customize F keys  →  
Lathe Settings   →  
▶Wireless Remote  →  
Motor Parameters →
```

There will be 2 options inside the function:

- Pair new remote
- Unpair remote

```
▶Pair new remote  →  
Unpair remote    →
```

- **Note:** *The bottom line shows the ID of the current paired remote.*

```
Remote ID: 12345678
```

## Pairing New Remote

- Select “Pair new remote” option to start the process to pair the new remote.
- A prompt screen will show to prompt the user to press the **<OFF> key on the remote.**

```
-- Pairing Remote --  
  
Please Press OFF  
key on the remote
```

## Unpairing Remote

- Select “Unpair remote” option while a remote is paired and the user will be prompted with an option to unpair the remote.
- Press **<F/R>** key to unpair remote.

```
-- Clear Remote ID --  
  
Unpair this remote?  
▶Menu:NO      F/R:YES
```

## Password Lock

### Setting the password

- Enter the lathe menu and navigate down to “Set Password” on the second page.
- Press the speed dial when the cursor is in line with the “Set Password” text.

```
► Set Password      →
  Clear Password    →
  Lock Lathe Now    →
  Protect Menus: No
```

- The screen will change to a screen to enter the new password for the lathe.
- Set the new password by using the keys <F1>~<F4>. The F keys will correspond to each digit of the password.
  - i.e. <F1> key will correspond to the first digit (far left)
  - Press <ON> once the new password is set to save the new password.

```
  (F1)  (F2)  (F3)  (F4)
+1000  +100  +10   +1
New Password
"0000"
```

### Locking the lathe

The lathe can be locked immediately from the “Lock Lathe Now” function. The lathe will immediately switch to the lock screen when entering this function.

- **Note:** The lathe will enter the lock screen when entering “Password lock” function in the main menu when “Protect Menus” option is turned ON.

```
Set Password      →
  Clear Password    →
► Lock Lathe Now  →
  Protect Menus: No
```

### Unlocking lathe using the password

The lathe can be unlocked by entering the password using the keys <F1>~<F4>. The F keys will correspond to each digit of the password (i.e. <F1> key will correspond to the first digit far left)

Press <ON> once the password has been entered to unlock the lathe.

```
  (F1)  (F2)  (F3)  (F4)
+1000  +100  +10   +1
Enter
Current Password
"0000"
```

## Clearing the password

The password can be cleared from the system by entering the “Clear Password” function.

This will clear the password stored in the system

```

Set Password      →
▶Clear Password   →
Lock Lathe Now    →
Protect Menus: No
  
```

## Lathe Settings

The lathe setting will contain the toggles for the following functions:

1. Assisted Brake
2. E-Stop Brake
3. Idle Stopping Function
4. Vibration Sensor
5. Factory Reset

```

Customize F keys →
▶Lathe Settings  →
Wireless Remote  →
Motor Parameters
  
```

Press the speed dial when the cursor is in line with the desired option to toggle between the ON and OFF states of each function.

```

Display Size: Large
▶Assisted Brake: ON
E-Stop Brake: ON
Idle=AutoStop: ON
  
```

Below table shows the function and the available states of the function:

Function Name	Available States	Description
<b>Assisted Braking</b>	ON/OFF	The assisted braking function engages the motor electronic brakes when the <OFF> button is pressed while the lathe motor is running to bring the motor to a complete stop.
<b>E-Stop Brake</b>	ON/OFF	When the function is turned on, this will engage the motor electronic brakes when the Emergency Stop switch is pressed while the lathe motor is running.
<b>Idle Stopping Function</b>	ON/OFF	When enabled, this function will automatically turn the lathe motor off when it detects the motor idling (No change in load) for a certain amount of time.
<b>Vibration Sensor</b>	OFF/LOW/MED/HIGH	The vibration sensor will shut the lathe motor off when it detects a vibration above a certain threshold.
<b>Factory Reset</b>	This option will commence the factory reset to restore all default lathe value.	

# Maintaining Your Lathe



## WARNING

Improper power connection may result in a risk of electrical hazard

Regular maintenances are essential when considering the long-term use of the lathe.

### Maintenance after each use

1. Clean the work area and lathe
2. Vacuum shavings and dust from the headstock, table and base

### Monthly maintenance

1. Wax coat the exposed cast iron parts with a good quality paste wax. Buff off thoroughly.
2. Check tightness of nuts and bolts
3. Clean all tapers to ensure a secure fit

### 6-months Maintenance

1. Lubricate the tailstock quill and its inside threads with a light coat of light weight oil.
2. Check for any rusts on underneath the tool rest, tailstock and on the lathe bed. If there is rust on the surface, remove it by using a rust removal agent with an abrasive sponge.
  - **Note:** *Some rust removal agents may leave a stain on the metal surface. Please check on an area where stains are not easily visible before applying on the actual metal surface.*

### Cleaning the Tool slide

If the tool slide becomes hard to move and adjust, cleaning and lubricating are required.

1. To make the tool slide move more freely along the bed, make sure the bed rails are clean. Apply some paste wax to the rails.
2. If the tool slide is hard to move towards or away from you, remove the tool slide from the lathe bed. Clean the tool slide camshaft (round eccentric rod) with a petroleum-based solvent. Lubricate the rod with lightweight oil or a silicone spray.
3. Slide the base back onto the lathe bed.

### Cleaning the Tailstock

If the tailstock quill becomes hard to use or the Handwheel is hard to turn, cleaning and lubricating are required.

1. Remove the 6mm set screw from the tailstock handwheel. If needed, turn the handwheel to expose the set screw.
2. Using a screwdriver, remove the keeper plate from the tailstock body.
3. Remove the quill by unscrewing the tailstock quill lock handle off from the tailstock body and extending the quill out all the way. Remove handwheel from the tailstock body.
4. Wipe clean all parts including the inside of the tailstock slot.
5. Lubricate the quill, quill lead screw and tailstock slot with lightweight oil, apply small amount of oil to the quill threads.
6. Reassemble.

# Firmware Update

The HMI software plays an important role in the control and functionality of the NOVA Orion lathe. The firmware loaded onto the HMI panel is responsible of controlling the features and performance of the lathe.

The firmware version of the HMI can be upgraded via the included USB cable accessory and a PC with internet access. Be sure to check <https://www.teknatool.com/upgrade-your-firmware/> periodically for firmware upgrades for your machine, which may allow new features or software improvements that could enhance the performance of the lathe.

## Checking the Firmware Version

The firmware version of the lathe can be checked from the “Version Info” function located on the last line of the lathe menu.

```
Password Lock      →
Firmware Upgrade   →
▶Version Info      →
```

The lathe version information will be shown in the screen shown below:

```
NOVA ORION DVR 1844
TEKNATOOL Int.
AC 3.6R2or1f 2019
```

The last line indicates the firmware version of both HMI and main controller.

## USB Mode

USB mode is used to perform the firmware update on the lathe HMI.

USB mode is activated by navigating down to the “**Firmware Upgrade**” function on the lathe menu.

```
Password Lock      →
▶Firmware Upgrade  →
Version Info      →
```

Press <F/R> to continue into entering USB mode.

Return to the menu screen by pressing <Menu>

```
- Firmware Upgrade -
Enter USB Firmware
  upgrade mode?
Menu:NO          F/R:YES
```



# Troubleshooting

## Mechanical Issue

SYMPTOM	PLACE TO CHECK	HOW TO RESOLVE
Excessive Vibration	<ul style="list-style-type: none"> <li>▪ Work attached to the lathe</li> <li>▪ Lathe Mounting</li> <li>▪ (Either on bench or stand)</li> </ul>	<ol style="list-style-type: none"> <li>1. Remove any work pieces/tools attached to the headstock, inspect if there is any foreign materials or damages to the threads.</li> <li>2. Attach the tools one at a time to check which part is causing the vibration</li> <li>3. Extra weights can be added to reduce the amount of vibration that occurs from large unbalanced work pieces</li> </ol>
Faceplate or chuck running out of true	<ul style="list-style-type: none"> <li>▪ Back of face plate</li> <li>▪ Threads</li> </ul> <p>Inner threads on faceplate Spindle thread on headstock</p>	<ol style="list-style-type: none"> <li>1. Inspect if there is any damage on the threads</li> <li>2. Mount the faceplate or chuck onto the machine and check if it is seating securely on the bearing.</li> </ol>
Turning tools not sliding smoothly across Tool rest	Tool rest surface	Lightly use sand paper or a grinder to smooth out the top surface of the tool rest.
Spur drive centre/live centre not holding in spindle or quill taper when turning	Morse Taper surface	<ol style="list-style-type: none"> <li>1. Inspect both male and female Morse Taper surfaces to check for any foreign materials or defects on the surface.</li> <li>2. Clean the surface and remount the tools</li> </ol>
Tailstock and Headstock centres not aligning	<ul style="list-style-type: none"> <li>▪ Lathe bed connection</li> <li>▪ Headstock detent position</li> <li>▪ Tailstock adjustment plate</li> </ul>	<ol style="list-style-type: none"> <li>1. Inspect all connections of the bed sections to make sure all the top surfaces are flush with one another.</li> <li>2. Check to ensure the headstock is properly locked in the zero-degree detent position.</li> <li>3. Loosen the tailstock adjustment plate located on the bottom of the tailstock and align the headstock and tailstock. Tighten the tailstock adjustment plate to finish.</li> </ol>
Tailstock Handwheel hard to turn or will not turn	<ul style="list-style-type: none"> <li>▪ Quill lock</li> <li>▪ Inside the tailstock quill housing</li> </ul>	<ol style="list-style-type: none"> <li>1. Check if quill lock on the tailstock is not engaged.</li> <li>2. Fully extend the tailstock quill out to extract the quill from its housing. Inspect both quill and housing surface and threads for any defects and foreign materials. Apply lubricant to quill surface and thread and reassemble.</li> </ol>
Tailstock binds while sliding along the bed	<ul style="list-style-type: none"> <li>▪ Lathe bed</li> <li>▪ Tailstock adjustment plate</li> </ul>	<ol style="list-style-type: none"> <li>1. Check for defects or foreign materials on the bed.</li> <li>2. Loosen the tailstock lock</li> </ol>
Tailstock jumps at bed section joints.	<ul style="list-style-type: none"> <li>▪ Lathe bed</li> <li>▪ Tailstock bottom surface</li> </ul>	<ol style="list-style-type: none"> <li>1. Inspect uneven surfaces on the lathe bed and make sure the bed connection areas are flush.</li> <li>2. Check for any defects and foreign materials on the bottom of the tailstock casting.</li> <li>3. Use sand paper to lightly sand down the defects on the lathe bed or the tailstock casting.</li> </ol>

## Electrical Issue



**Always isolate the lathe from its power source  
before carrying out the following checking procedures**

<b>SYMPTOM</b>	<b>PLACE TO CHECK</b>	<b>HOW TO RESOLVE</b>
<b>NO Display screen when the main power is on</b>	10-pin ribbon cable	<ol style="list-style-type: none"><li>1. Dismount the HMI from the headstock</li><li>2. Unplug and re-plug the grey ribbon cable firmly as it may have become loose during shipping</li></ol>
<b>Rotor Fault</b>	<ul style="list-style-type: none"><li>▪ Spindle</li><li>▪ Index Pin</li></ul>	<ol style="list-style-type: none"><li>1. Check if the spindle index is engaged. Disengage the spindle index if engaged.</li><li>2. Check if there is anything preventing the spindle to turn</li><li>3. Remove the obstruction and try starting the motor again</li></ol>
<b>RP State Error (0 or 1)</b>	Motor optical sensor	<ol style="list-style-type: none"><li>1. Turn the spindle by hand to see if this will cause a breakthrough in the material that has built up around the sensor.</li><li>2. Blow air through the headstock blowing away the foreign material built up around the sensor.</li></ol>
<b>PFC Corrector (Flashing)</b>	Headstock body	<ol style="list-style-type: none"><li>1. CAREFULLY Touch the lower section of the headstock and see if it is hot to the touch</li><li>2. Turn off the headstock main power switch and leave it to cool down for a period of time. Restart the headstock after it has cooled down.</li></ol>

Please contact our customer service team as [service@teknatool.com](mailto:service@teknatool.com) if the above procedures did not resolve your issue.

# Teknatool Warranty



## NOVA Limited Warranty

4499 126<sup>th</sup> St North | Clearwater Florida 33762  
 teknatool.com | 727.954.3433

This NOVA product is backed by a registered warranty from the date of purchase and only to the original purchaser. These limited warranties are non-transferable. Under no circumstances will Teknatool International Ltd or Teknatool USA Inc. be liable for incidental, special, indirect, and consequential damages or expenses, including loss of profits or loss of operations.

**INSPECTION:** Buyer shall inspect all goods within thirty (30) days of receiving product confirming all parts are in good condition and accounted.

**GUARANTEE:** Teknatool International Ltd and Teknatool USA Inc. will repair or replace, at its expense and option, a NOVA product which under normal use and intended operation, has proven to be defective in workmanship or material. Teknatool will be granted a reasonable opportunity to verify the alleged defect by inspection and testing. Teknatool will not be responsible for any asserted defect, which has resulted from normal wear, misuse, abuse, power surges or excess voltage fluctuation, or using in a manner or with material not consistent with proper use, repair or alteration made by anyone other than an authorized service facility or representative.

Under these Limited Warranties, the sole liability of Teknatool is limited to repair, or at its option, replacement the applicable product or part not in conformity with these Limited Warranties. REFUNDS ARE NOT AVAILABLE. If within the warranty period, identical materials are unavailable at the time of repair or replacement, *IN NO EVENT SHALL NOVA TEKNATOOL'S RESPONSIBILITY EXCEED THE PURCHASE PRICE OF THE PRODUCT OR ITS REPLACEMENT AND RESERVES THE RIGHT TO USE REFURBISHED PARTS.*

**CONDITIONS:** Prior warranty registration is not required but advised via <https://www.teknatool.com/register-your-warranty/>; however, documented proof of purchase (sales receipt/invoice showing date, location, and purchase price paid) must be provided at the time of claim. *\*Repairs are charged hourly. In addition, customer pays for shipping to/from and provides own shipping contain; \*\*Warranty Repairs: customer pays for shipping to/from and provides own shipping container; repairs are covered within warranty.*

**OVERSEAS CUSTOMERS:** Our NOVA Distributors and agents will issue their own warranty to cover this product. Terms may vary from those stated above; please check with your dealer. In North America, the warranty covers the Continental USA only. For Alaska, Hawaii and other areas, warranty covers replacement of parts only and excludes transport costs.

Product	Electrical	Mechanical
All Lathes and *Accessories (except COMET) Comet Series Drill Presses and *Accessories <i>*Excludes belts and consumables</i>	2 years 1 year 2 years	5 years 2 years 5 years
All Chucks & Accessories Jaws		6 years 6 years
Chisels: -Dovetail -Smart Chisel Handle		2 years 1 year

**TO FILE A CLAIM:** Contact CUSTOMER SERVICE via <https://www.teknatool.com/contact-us/> or [support@teknatool.com](mailto:support@teknatool.com) with a full description for claim to include pictures/videos. All claims must include the original bill of sale, the product serial number (when available), and be filed within the applicable warranty period. Teknatool reserves the right to require defective parts be returned upon request. You must plan with Teknatool to schedule the transportation of the parts from your home to the retailer or from the retailer to your home. A RETURN AUTHORIZATION (RA) form will be sent to you via email. Items shipped to Teknatool without a RA form will be refused at shipper's expense. If the retailer from which you purchased the product is not able to service your product, contact Teknatool in writing at [service@teknatool.com](mailto:service@teknatool.com).

Our policy is one of continuous improvement. We therefore reserve the right to change specification/design without notice. This warranty is Teknatool International Ltd and Teknatool USA Inc. sole warranty whether written or verbal, whether expressed or implied by law, trade, custom, or otherwise, whether of merchantability, fitness for purpose, or otherwise, except for remedies available to customers under the Consumer Guarantees Act or other legislation

# NOVA Orion Headstock Breakdown

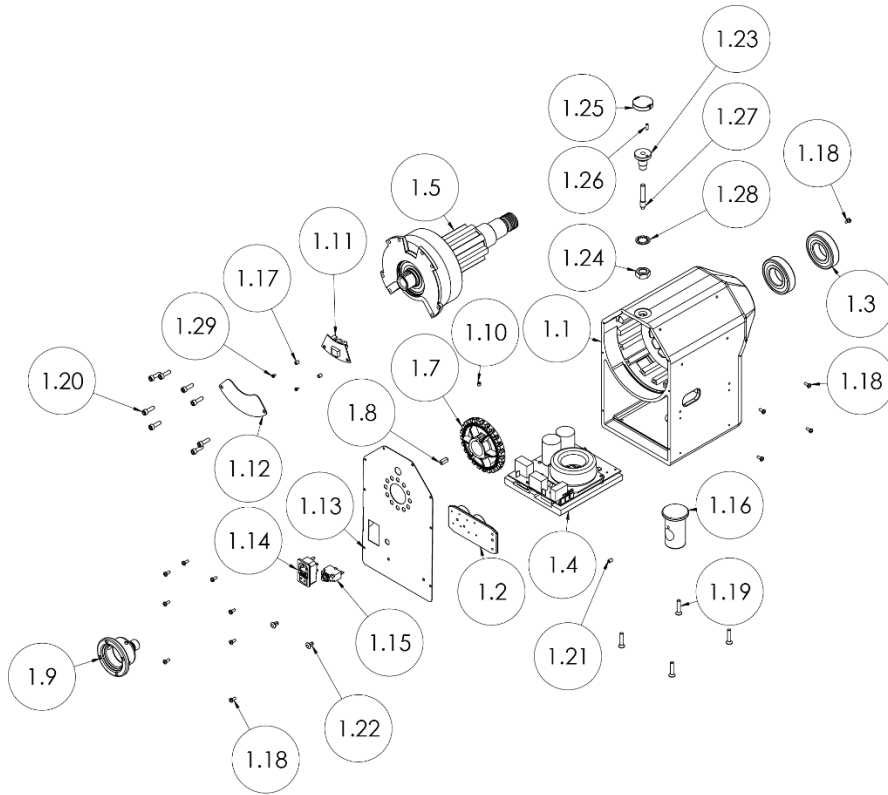

# NOVA Orion Tailstock Breakdown

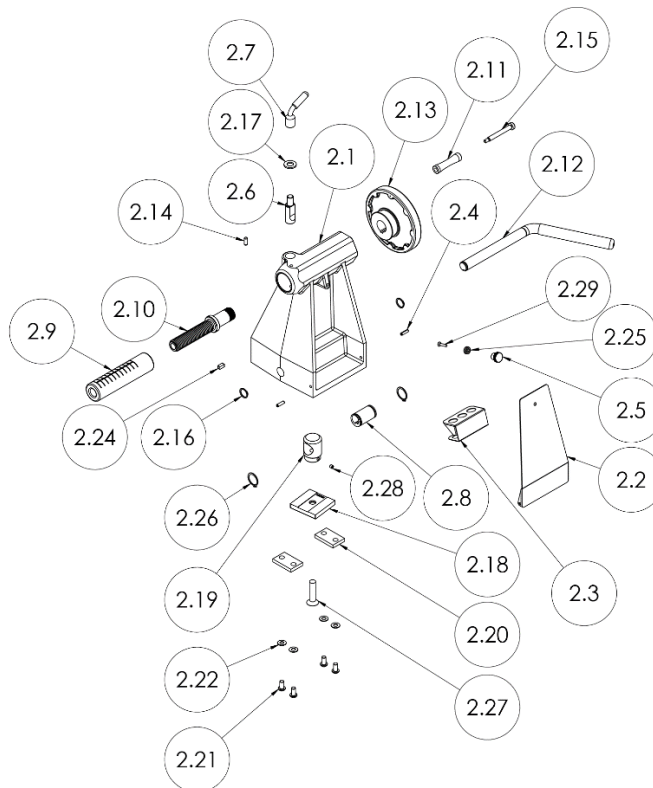

# NOVA Orion Toolrest Breakdown

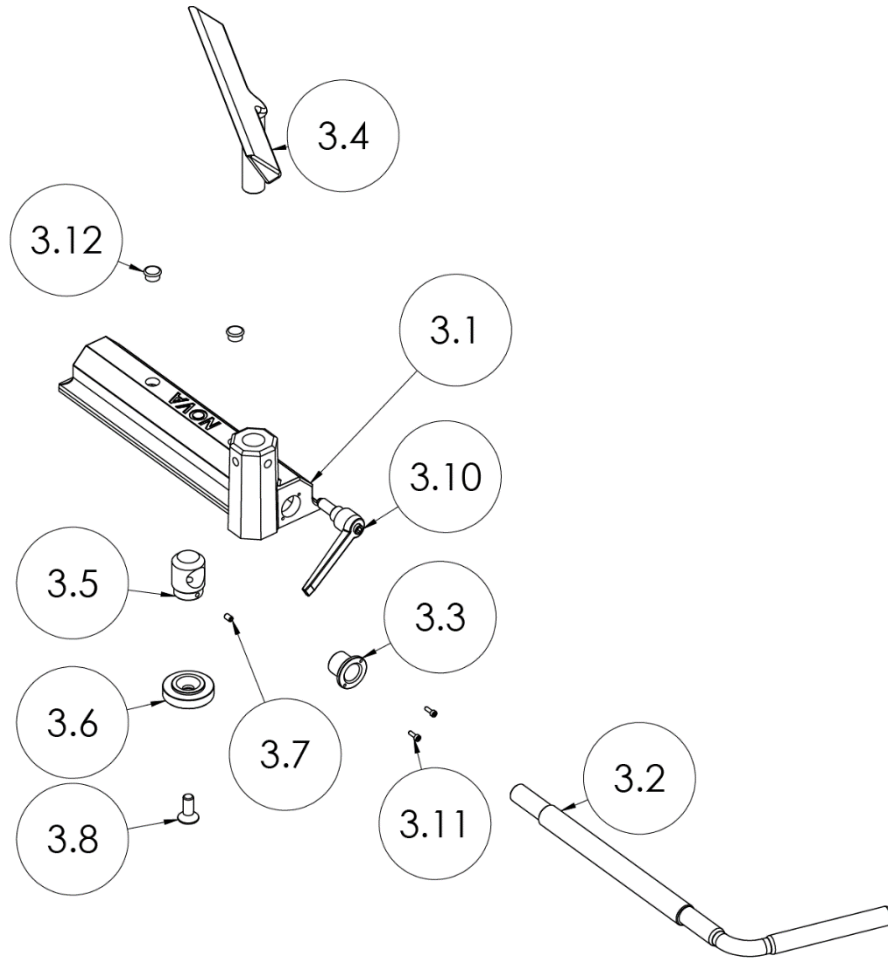

# NOVA Orion HMI Breakdown

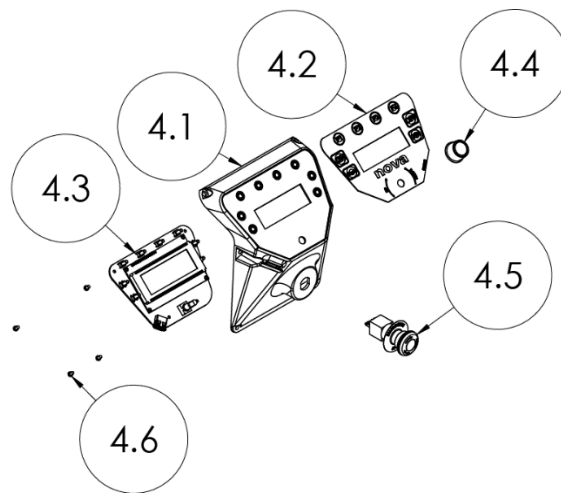

# NOVA Orion Bed and Stand

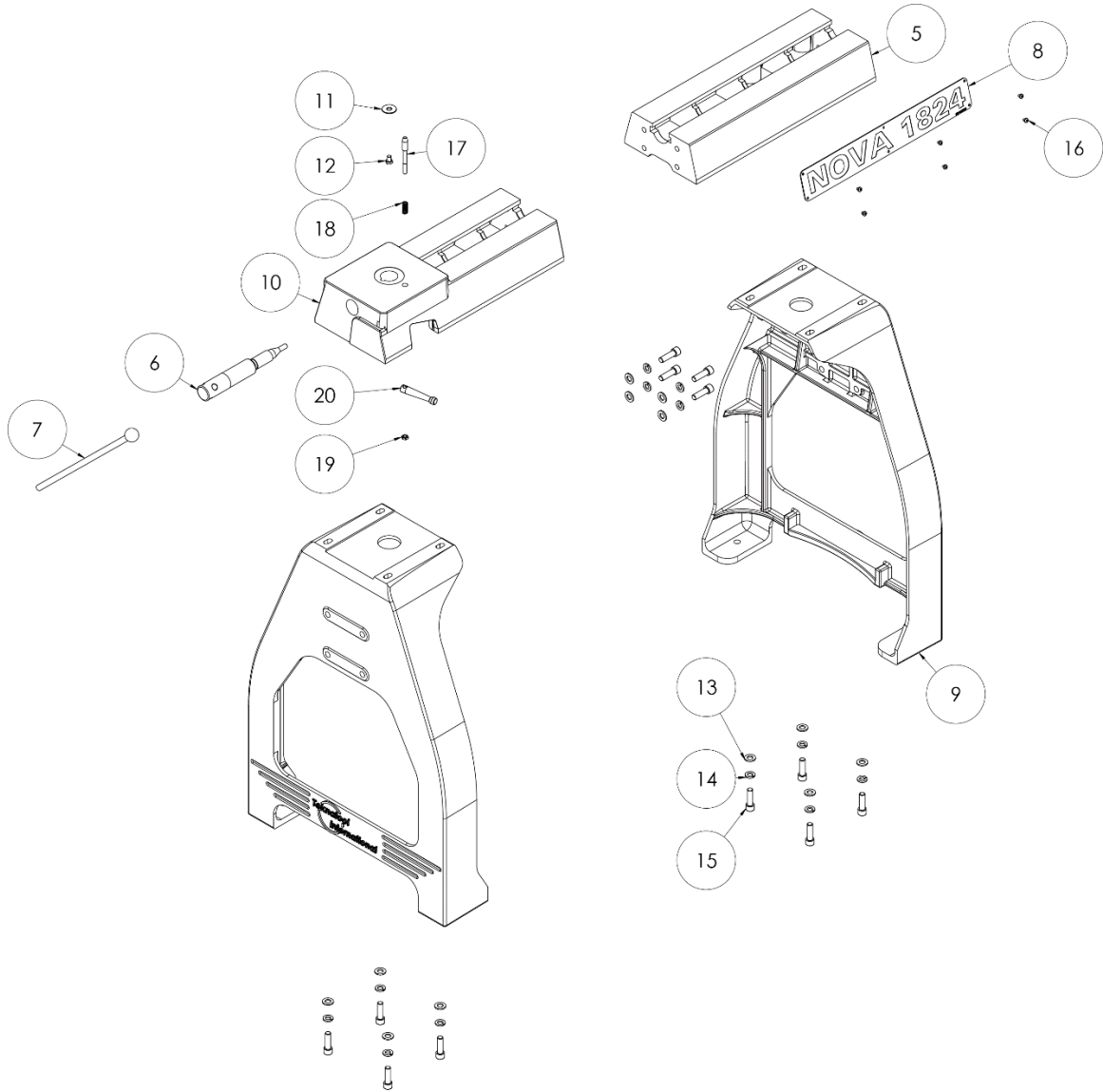

# NOVA Orion Lathe Parts List

ITEM NO.	DESCRIPTION	SKU	QTY.
1	Headstock Assembly	5699001	1
1.1	NOVA Orion Headstock Casting	5699015	1
1.2	EMI Filter [only for 240V models]	55170	1
1.3	6207 Bearing	6207ZZ	2
1.4	Main Control Board	55168	1
1.5	Rotor Assembly	5699002	1
1.6	External Circlip 35mm	EC35	1
1.7	Index Wheel	55011	1
1.8	Index Wheel Key	55051	1
1.9	Lathe Handwheel	LHB	1
1.0	Index Wheel Set Screw M6x6	SZ0606	1
1.11	Optical Sensor	55020	1
1.12	RPS Cover Plate	55174	1
1.13	Headstock Back Cover Plate	5699042	1
1.14	Main Power Switch	5699044	1
1.15	Thermal Breaker	5699045	1
1.16	Swivel Pin	5699043	1
1.17	Optical Sensor Location Dowel	55055	2
1.18	Panel Mounting Screws	MPB0410	14
1.19	Main Board Mounting Screws	CM0630	4
1.2	Rotor Assembly Mounting Bolt	C06020	8
1.21	Headstock Swivel Pin Positioning Set Screw	SZ0610	1
1.22	Plastic Rivets for EMI Filter		2
1.23	Lock Pin Housing	55035	1
1.24	Hex Nut 14mm	NH14	1
1.25	Lock Knob	55036	1
1.26	Index Pin Tension Pin	TPI31658	1
1.27	Detent Pin	55033	1
1.28	Index Pin Spring Washer	55137	1
1.29	Optical Sensor Mounting Screw	MPB0305	2
2	Tailstock Assembly	5699003	1
2.1	Tailstock Casting	5699011	1
2.2	Tailstock Sheet Metal Door	5699013	1
2.3	Tailstock Tool Holder	5699014	1
2.4	Tension Pin 5mm	TP0518	2
2.5	Tailstock Door Knob	5699032	1
2.6	Tailstock Quill Lock Pin	5699026	1
2.7	Tailstock Quill Lock Handle	55029	1
2.8	Tailstock Cam Shaft Ring	5699031	1
2.9	Tailstock Quill	5699040	1
2.1	Tailstock Quill Lead Screw	5699041	1
2.11	Tailstock Handwheel Handle	5699028	1
2.12	Tailstock Locking Lever	5699029	1
2.13	Tailstock Handwheel	5699027	1
2.14	Tailstock Quill Dowel Pin	5699025	1
2.15	Tailstock Handwheel Handle Stud Bolt	5699046	1
2.16	External Circlip 18mm	EC18	2
2.17	Flat Washer 12mm	FW12	1
2.18	Tailstock Locking plate	5699052	1

**\*Note:**

Item No 4.7 is only included in the packages for Australia/ New Zealand and Europe.

ITEM NO.	DESCRIPTION	SKU	QTY.
2.19	Tailstock Cam Follower	5699048	1
2.2	Tailstock Alignment Plate	5699050	2
2.21	Tailstock Alignment Plate Screw	BHC0816	4
2.22	Tailstock Alignment Screw Washer	FW08	4
2.23	Tailstock Handwheel Locking Nut	LN25	1
2.24	6mm Tailstock Handwheel Key	5699039	1
2.25	Tailstock Door Lock Magnet	5699019	1
2.26	Tailstock Cam Shaft Ring Retaining Circlip	EC24	2
2.27	Tailstock Locking Plate Mounting Bolt	C12050	1
2.28	Tailstock Cam Follower Set Screw	SZ0606	1
2.29	Tailstock Door Magnet Mounting Bolt	CM0420	1
3	Tool Slide Assembly	5699004	1
3.1	Tool slide	5699022	1
3.2	Tool slide lock Camshaft	5699023	1
3.3	Camshaft Ring	5699038	1
3.4	Tool Rest	5699024	1
3.5	Tool Slide Lock Boss	5699017	1
3.6	Tool Slide Lock Plate	5699012	1
3.7	M6x10 Set Screw	SZ0610	1
3.8	Tool Slide Lock Plate Mounting Screw	CM1230	1
3.9	Cam Shaft Ring B	5699037	1
3.1	Tool rest Locking Handle	5699036	1
3.11	Cam Shaft Ring Mounting Screws	C04012	2
3.12	Tool Slide Caps	HP16	2
4	HMI Assembly	5699005	1
4.1	Orion Interface Plastic Panel	5698000	1
4.2	HMI Keypad	5699030	1
4.3	Interface Circuit Board	5699051	1
4.4	Speed Control knob	5699034	1
4.5	Emergency Stop Switch	5699016	1
4.6	Interface Board Mounting Screw	MPB0305	4
4.7*	External EMS	55226	1
5	Main Bed Extension	5699035	1
6	Headstock Lock Pin	5699020	1
7	Operating Bar	5699033	1
8	Bed Metal Badge	5699081	1
9	NOVA Orion Lathe Stand	5699018	2
10	NOVA Orion Main Bed	5699021	1
11	Headstock Centre Pin Washer	FW08	1
12	Headstock Centre Pin Bolt	SZ0812	1
13	Bed Assembly Bolt Washer	FW12	13
14	Bed Assembly Spring Washer	SW12	12
15	M12 x 40 Bed Assembly Bolt	C1240	12
16	Bed Logo Plate Mounting Screws	MPB0506	6
17	Detent Pin	5699047	1
18	Detent Pin Spring	5699049	1
19	Detent Pin Nut	NH08	1
20	Detent Pin Handle	55176	1

# NOVA Orion Wiring Diagram

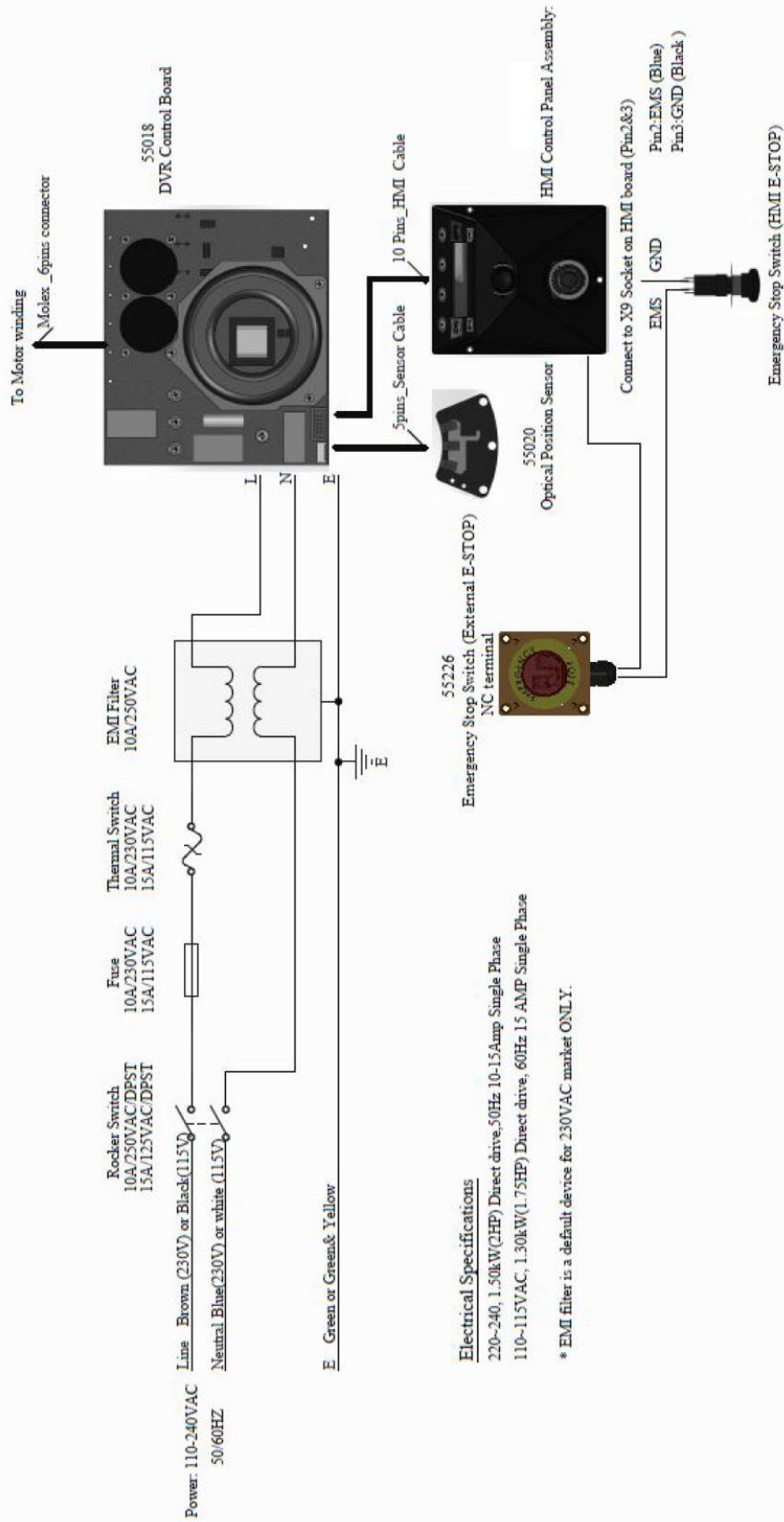



## CALIFORNIA RESIDENTS PROPOSITION 65

### Attention California Residents

California's Proposition 65 entitles California consumers to special warnings for products that contain chemicals known to the state of California to cause cancer and birth defects or other reproductive harm if those products expose consumers to such chemicals above certain threshold levels. We care about our customers' safety and hope that the information below helps with your buying decisions. The general Proposition 65 notice is as follows:

- ⚠ **WARNING:** Drilling, sawing, sanding or machining wood products can expose you to wood dust, a substance known to the State of California to cause cancer. Your risk from exposure to these chemicals varies, depending on how often you do this type of work. To reduce your exposure, work in a well-ventilated area and with approved safety equipment, such as dust masks that are specially designed to filter out microscopic particles.
  
- ⚠ **WARNING:** This product can expose you to chemicals (Rust Prevention Oil) which are known to the State of California to cause cancer. Do not touch your eyes or face after unpacking until you have washed your hands. Its advised to wear disposable gloves while unpacking and while cleaning the product down for first use. Always unpack and clean in a well-ventilated area. Always wash your hands after unpacking the product for first use. Dispose of packaging bags thoughtfully. Read the Safety Data Sheet for this Rust Protectant Oil here: [MSDS for rust protection](#)

For more information go to [www.P65Warnings.ca.gov](http://www.P65Warnings.ca.gov)



21 May 2020

NOVA Orion 18" DVR Lathe Manual

128-0520-006

© Teknatool® International 2020

All rights reserved. Teknatool® USA Inc.

Due to NOVA's continuous product improvement and development policy, specifications, features and images contained in this manual may change without notice. Teknatool is not responsible for omissions or errors herein, or for incidental damages in connection with the furnishing of this information.