

Jointer

Model 4275

Owner's Manual

For Models Manufactured Since 06/2019



Oliver Machinery
1-800-559-5065
6902 S 194th St, Kent, WA 98032

info@olivermachinery.net
WWW.OLIVERMACHINERY.NET

Stock Number: 4275.101.4S
4275.102.4S
Manual Version: 1.0.0



READ AND UNDERSTAND ALL INSTRUCTIONS IN THIS MANUAL BEFORE ATTEMPTING TO ASSEMBLE OR OPERATE THE MACHINE.

FOLLOW THE INSTRUCTIONS AND THINK SAFETY!

THE OWNER OF THIS MACHINE IS SOLELY RESPONSIBLE FOR THE SAFETY OF ANYONE USING THIS MACHINE. SUCH RESPONSIBILITY INCLUDES BUT NOT LIMITED TO:

- **PROPER ASSEMBLY, OPERATION, INSPECTION, MAINTENANCE, AND RELOCATION OF THE MACHINE.**
- **PROPER TRAINING FOR THE OPERATORS AND ENSURES THIS MANUAL IS AVAILABLE AT ALL TIMES.**
- **USAGE AUTHORIZATION.**
- **USAGE OF SAFETY AND PROTECTION DEVICE.**

OLIVER MACHINERY DISCLAIMS ANY LIABILITY FOR MACHINES THAT HAVE BEEN ALTERED OR ABUSED. OLIVER MACHINERY RESERVES THE RIGHT TO EFFECT AT ANY TIME, WITHOUT PRIOR NOTICE, THOSE ALTERATIONS TO PARTS, FITTINGS, AND ACCESSORY EQUIPMENT WHICH THEY MAY DEEM NECESSARY FOR ANY REASON WHATSOEVER.

**** SAVE THIS MANUAL FOR FUTURE REFERENCES. ****

PROP 65 NOTICE

WARNING: Drilling, sawing, sanding or machining wood products can expose you to wood dust, and/or other chemicals known to the State of California to cause cancer, birth defects or other reproductive harm.

Some examples of these chemicals are:

- Lead from lead-based paints.
- Crystalline silica from bricks, cement and other masonry products.
- Arsenic and chromium from chemically-treated lumber.

Avoid inhaling wood dust and other harmful chemicals. Use a dust mask and/or other safety devices for personal protection.

For more information go to <http://www.P65Warnings.ca.gov/wood>

Table of Contents

Introduction	6	Removing Machine from Crate	20
Specifications	7	Cleaning	20
Quick View	7	Assembly	21
Product Dimensions	7	Setup Control Panel	21
Shipment Info	7	Inspect / Adjust Jointer Tables (Optional).....	22
Electricals	7	Install Cutterhead Guard.....	22
Motor	8	Leveling Machine	23
Jointer Capacity and Performance	8	Dust Collection	23
Fence	8	Wiring and Grounding	24
Cutterhead	8	Wiring Instructions.....	24
Table	8	Controls and Components	25
Measurements	9	Control Panel	25
Safety	9	Infeed Table Height Adjustment Handwheel and Depth Scale	25
Others	9	Infeed Table Depth Stop Knob	26
Identification	10	Outfeed Table Height Lever and Lock	26
Safety	12	Fence	26
General Safety Guidelines	12	Digital Readout (DRO)	27
Safety Guidelines Specific to Jointer	13	DRO Calibration	27
Electricals	15	Test Run	28
Minimum Circuit Size Required for Model 4275 Jointer	15	Operation	29
Grounding	15	Preparation	29
Electrical Wiring	15	Inspect Wood Grain	30
Setup	17	Squaring Stock	30
Shop Preparation	17	Surface Planing	31
Space Requirement	17	Edge Jointing	33
Load Limits	17	Beveling	33
Electricals	17	Rabbet Cutting	34
Lighting.....	17	Common Cutting Problems	35
Safety Labels	17	Snipe.....	35
Dust Collection	17	Chipping	35
Receiving	18	Fuzzy Grain	35
Moving Machine into the Shop.....	18	Accessories	36
Unboxing	18	460V Conversion Kit	36
Inventory.....	19	Cutter Inserts	36

Touchup Paint	36
Power Feeder	37
Maintenance	38
Maintenance Schedule	38
Inspect / Adjust Jointer Tables	39
Inspect Outfeed Table Height	39
Adjust Outfeed Table Height	39
Inspect Outfeed Table Parallelism	39
Inspect Infeed Table	40
Adjust Table Parallelism/Coplanarity	41
Infeed Table Adjustments	43
Infeed Table Depth Stops Adjustments	43
Cutterhead Maintenance	44
Rotate / Replace Cutter Inserts	44
Adjust Fence Positive Stops	45
Adjust Belt Tension	46
Align Belt Pulleys	47
Troubleshooting	48

Wiring Diagram	51
For Stock # 4275.101.4S (230V, 1Ph)	51
For Stock # 4275.102.4S (230/460V, 3Ph)	52
Parts List	53
Fence Assembly	53
Table and Cutterhead Assembly	54
Base Assembly	55
Motor and Cabinet	56
Maintenance Record	57
Notes	66
Warranty and Service	67
Appendix	68
US Standard – Metric Conversion Chart	68

Introduction

Thank you for choosing Oliver! This manual contains important information on how to safely set up, operate, and maintain this machine. Please take the time to read through this manual, and make sure you understand all the instructions.

While this manual may provide tips on optimizing the result of your workpiece, the manual is not intended as a substitute for formal woodworking training. If you need to know how to safely perform an operation, please consult knowledgeable and qualified sources before proceeding further.

We made every effort to keep this manual up-to-date. Instructions, specifications, drawings, and photographs in this manual should match the machine delivered. If you find any differences, or anything that seems confusing in this manual, or some instructions are not available, please check our website for an updated version:

WWW.OLIVERMACHINERY.NET/MANUALS

Alternatively, you can contact our technical support for help:

1-800-559-5065

Before calling, please note down the manufacture date and serial number of the machine. You can find the information on a nameplate located on the back of the machine, right above the electrical junction box. This information is needed to provide proper technical support, and to determine if an updated manual is available for your machine.

Please let us know how well this manual serves you. If you have any suggestions, please call the number above or email us at:

info@olivermachinery.net

We love to hear from our customers and make improvements.

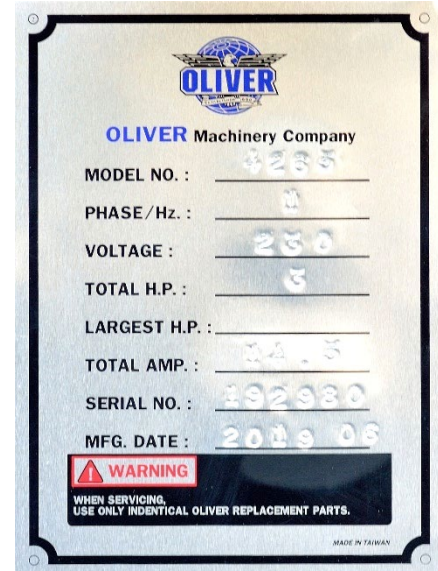

Specifications

Quick View

Model	4275 Jointer	
Stock Number	4275.101.4S	4275.102.4S
Motor	Baldor TEFC Induction Motor 5HP, 230V, 1Ph	Baldor TEFC Induction Motor 7.5HP, 230/460V, 3Ph
Jointer Size	16"	
Max. Depth of Cut (Jointing)	1/8"	
Max. Depth of Cut (Rabbeting)	3/4"	
Bevel Joining	0-45 Degrees	
Dimensions	100"(L) x 42"(W) x 46"(H)	
Footprint	52-1/2"(L) x 24-1/2"(W)	
Fully Assembled Weight	1,099 lbs.	
Warranty	1 Year (Motor and electronics) 2 Years (All other parts)	

Product Dimensions

Jointer Fully Assembled and Fence Fully Retracted	100"(L) x 42"(W) x 46"(H)
Footprint	52-1/2" (L) x 24-1/2"(W)
Fully Assembled Weight	1,099 lbs.

Shipment Info

Type	Wood Crate with Pallet Base
Content	Jointer with Included Accessories
Dimensions	103" (L) x 34"(W) x 52"(H)
Weight	1,136 lbs.
Approximate Setup Time	60 minutes
Must Ship Upright	YES
Stackable	NO

Electricals

Stock Number	4275.101.4S	4275.102.4S
Power Requirement	230V, 1Ph, 60Hz	230/460V, 3Ph, 60Hz
Full Load Current Rating	19.5A	16.8/8.4A
Recommended circuit size	30A	30A
Power Switch Type	Magnetic switch with overload protection.	
Connection Type	Cord and plug not included. Electrical hookups required.	
Overload Protection	Equipped	

Motor

Motor Type	Baldor TEFC Induction Motor	
Horsepower	5HP	7.5HP
Speed	3600 RPM	3600 RPM
Efficiency	76%	88.5%
Power Factor	87	91
Power Transfer Mechanism	Poly V-belt and pulleys	
Bearing type	Permanently sealed ball bearing	

Jointer Capacity and Performance

Maximum Stock Width	16"
Maximum Depth of Cut for Jointing	1/8"
Maximum Depth of Cut for Rabbeting	3/4"
Minimum Stock Thickness	1/2"
Minimum Stock Length	12"

Fence

Dimensions	47" (L) x 6" (H)
Fence Stops	45 and 90 Degrees
Auxiliary Fence Dimensions	47" (L) x 1-1/8" (W) x 1/2" (H)
Material	Extruded aluminum

Cutterhead

Cutterhead Type	Helical
Cutterhead Diameter	3-55/64"
Cutterhead Speed	5500 RPM
Number of Cutter Inserts	76
Number of Rows of Cutter Inserts	4
Cutter Insert Type	Four-sided, indexable German made carbide
Cutter Insert Diameters	15mm x 15mm x 2.5mm
Cutter Blade Angle	30 degree
Cutter Insert Screw Tensioning Torque	52-60 lbs.-inch

Table

Table Dimensions	100" (L) x 16" (W)
Table Height Above Ground	34-3/4"
Table Lifting / Adjustment Mechanism	Parallelogram
Material	Precision ground cast iron

Measurements

Measurement Units	Inch/mm
Measurement Devices	Wixey Digital Readout
Digital Readout Resolution	1/32" / 0.005" / 0.05mm
Digital Readout Accuracy	±1/500" / 0.002" / 0.05mm
Backup Measurement Device	Cutting depth scale with pointer.

Safety

Stock Number	4275.101.4S	4275.102.4S
Number of Dust Ports	1	
Dust Port Size	6"	
Minimum CFM Required	700 CFM	
Sound Rating @ 2' distance	90-95 dB	92-96 dB

Others

Serial Number Location	On the back of the machine.
Spare Parts Included	Ten cutter inserts and compatible Torx screws.
Certification	CSA 175370
Country of Origin	Taiwan

Identification

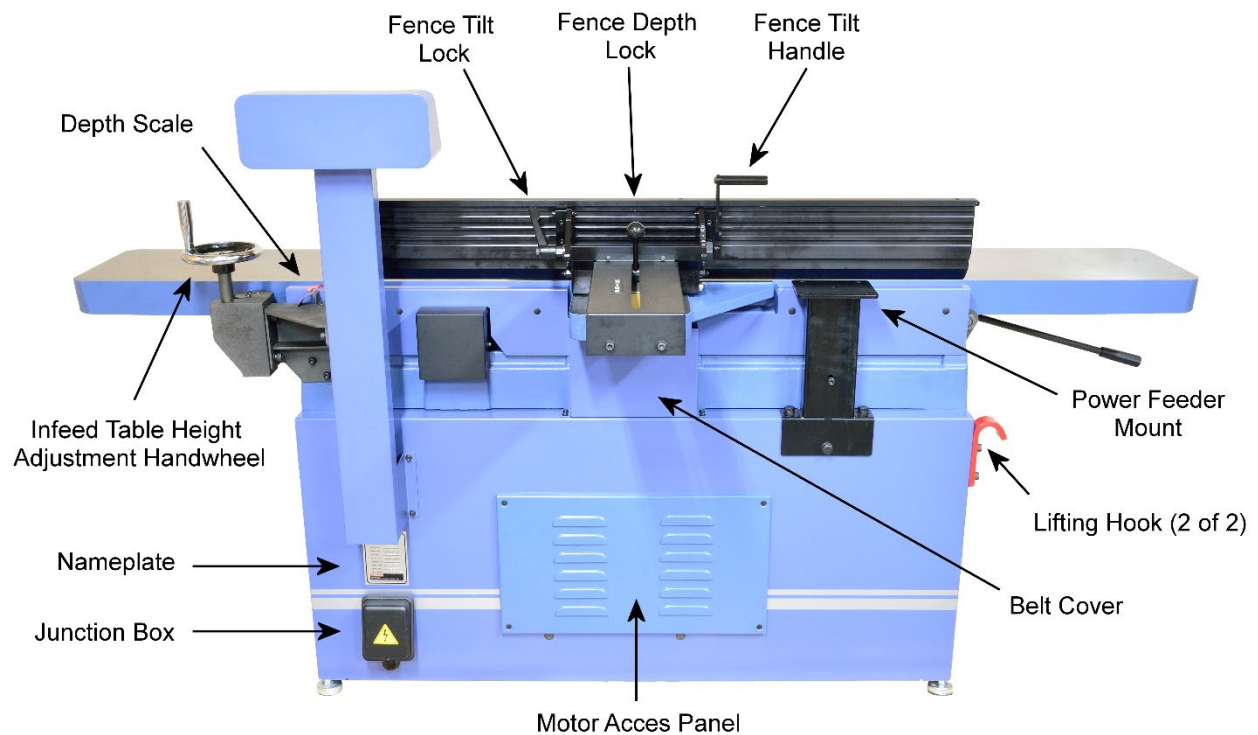
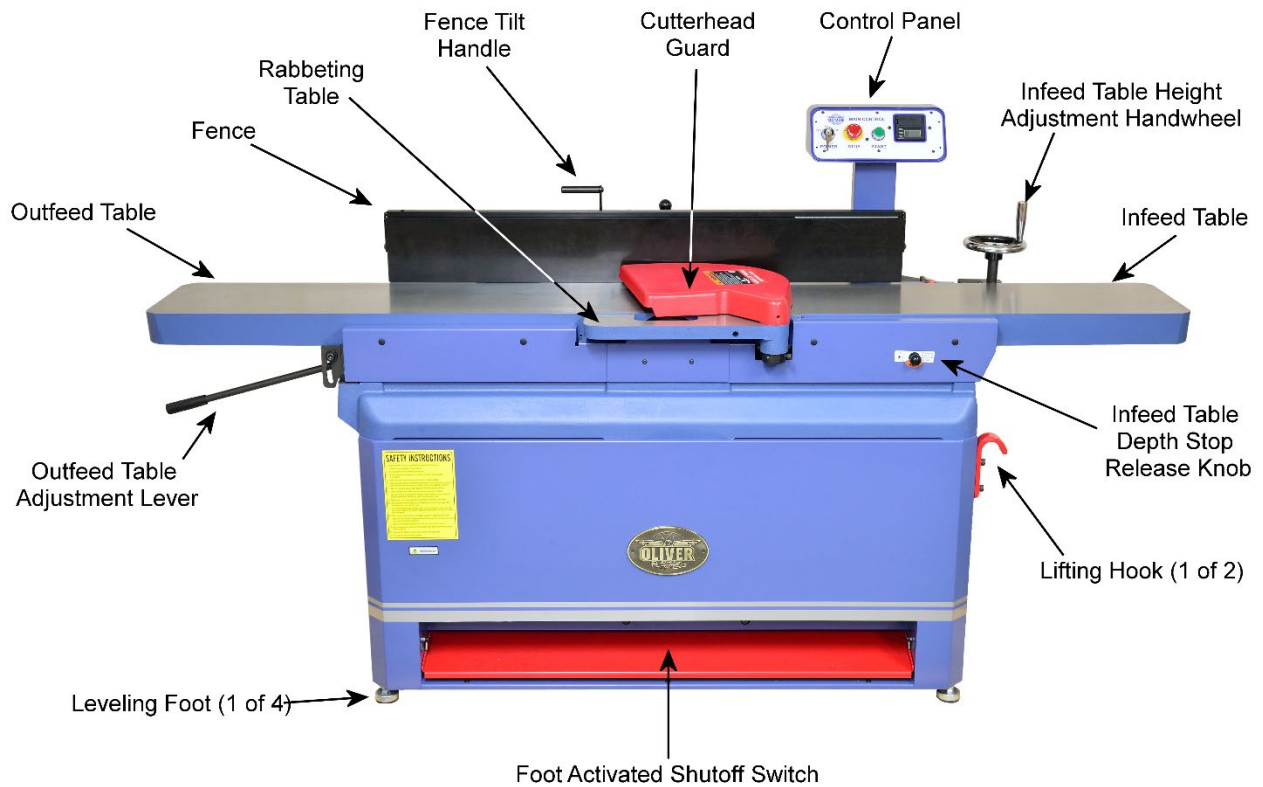

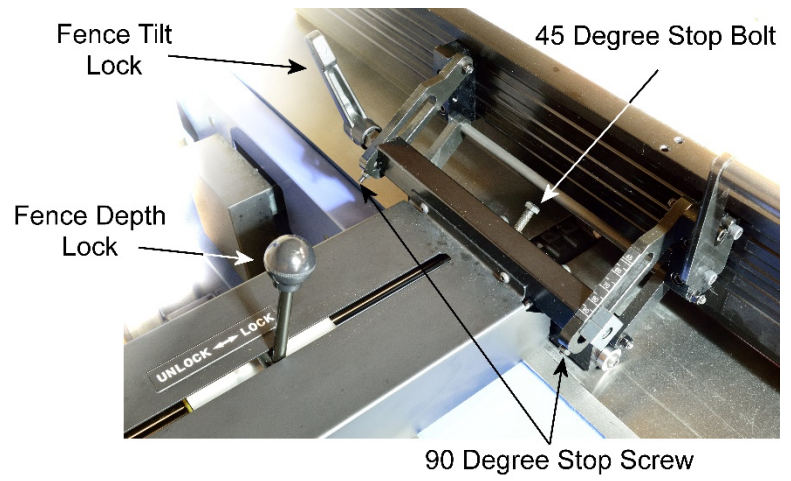
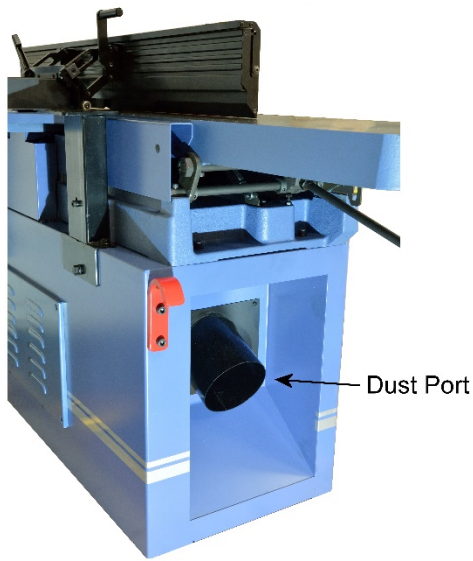

Control Panel

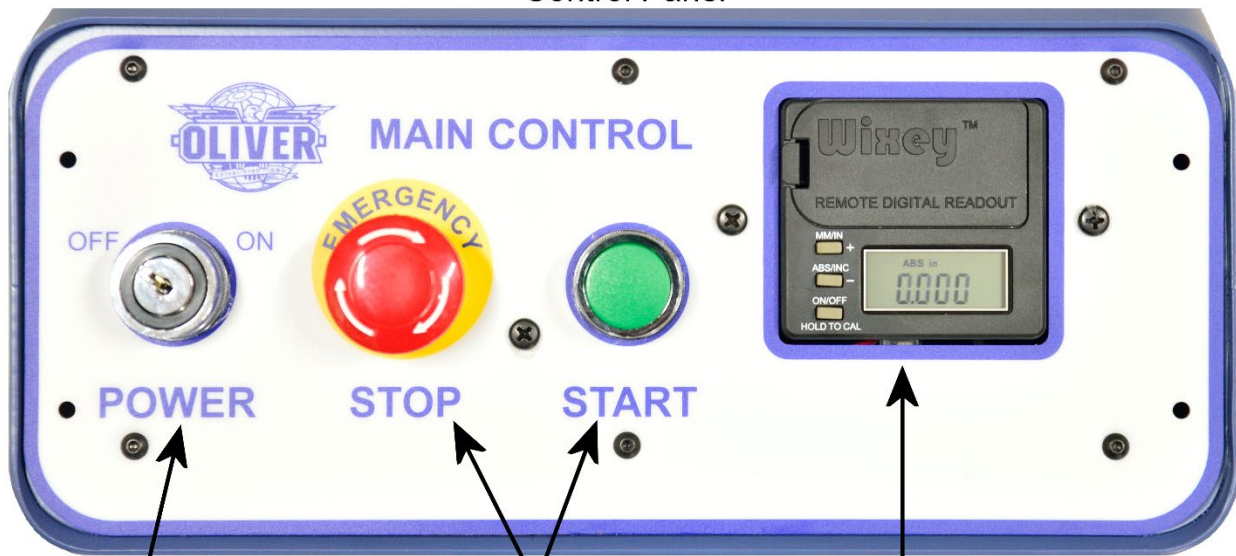



Key-Operated
Main Switch

On/Off Switch

Digital Readout

Safety

Oliver Machinery has made every attempt to provide a safe, reliable, easy-to-use piece of machinery. Safety, however, is ultimately depending on the individual machine operator. **Before operating this machine, please become familiar with the following safety labels and guidelines.**

 DANGER	This indicate an imminent hazardous situation which, if not avoided, WILL cause death or serious injury.
 WARNING	This means if the warning is not taken seriously, it CAN cause death or serious injury.
 CAUTION	This mean if the precaution is not taken, it MAY cause minor or moderate injury.
IMPORTANT	This is a tip about proper operation of the machine to avoid machine damage.

General Safety Guidelines

1. **FAMILIARIZE** yourself with all safety instructions found in this manual. Know the limitations and hazards associated with this machine. Do not operate / service this machine until you are properly trained.
2. **ELECTRICAL GROUNDING**, when done properly, reduce the risk of electrocution, shocks and fire. Make certain that the machine frame is electrically grounded and that a ground lead is included in the incoming electrical service. In cases where a cord and a plug are used, make certain that the grounding plug connects to a suitable ground. Follow the grounding procedure indicated in the electrical code of your area.
3. **DISCONNECT** the machine from power before performing any service, maintenance, or adjustments. A machine under repair should be RED TAGGED to show it should not be used until the repair is complete.
4. **EYE PROTECTION**: Always wear an approved safety face shield, goggles, or glasses that complies with ANSI Z87.1 and CSA Z94.3 standards. Common eyeglasses are not safety glasses, and may not provide adequate protection.
5. **EAR PROTECTION**: Use hearing protective devices where the noise exceeds the level of exposure allowed in Section 1910.95 of the OSHA Regulations. When in doubt, use it.
6. **OTHER PERSONAL PROTECTION**: Before operation, remove tie, rings, watch and other jewelry. Roll up sleeves above elbows. Remove all loose outer clothing and confine long hair. Protective type footwear should be used. Do not wear gloves unless it is instructed to perform particular step(s) in the manual.
7. **GUARDS**: Keep machine guards in place for all applicable operations. If any guards are removed for maintenance, DO NOT OPERATE machine until all guards are reinstalled. Check clearance between the guards and the cutter before starting the machine.
8. **WORKPLACE SAFETY**: Keep the floor around the machine clean. Scrap material, saw dust, oil and other liquids increase the risk of tripping or slipping. Be sure to clean up the table before starting the machine. Make certain the work area is well lighted and that a proper exhaust system is used to

minimize dust. Use anti-skid floor strips on the floor area where the operator normally stands and mark off machine work area. Provide adequate work space around the machine.

9. **ACCESS CONTROL** should be enforced so only trained personnel can access the work area and operate the machine. Use childproof power switch when applicable.
10. **STAY ALERT** at all times. Do not operate this machine while under the influence of drugs/alcohol, or when not feeling well.
11. **REPLACEMENT PARTS:** Use only genuine Oliver Machinery replacement parts and accessories recommended for this machine. Generic parts made by other manufacturers may create a safety hazard, and WILL void the factory warranty and other guarantees.
12. **PROPER USE:** Do not use this machine for other than its intended use. If used for other purposes, Oliver Machinery disclaims any real or implied warranty and holds itself harmless for any injury or damage which may result from that use.

Safety Guidelines Specific to Jointer

Before Work Begin:

1. **USE ONLY NATURAL, SOLID WOOD.** Do not joint any material such as plywood, MDF, OSB, laminate or anything that can disintegrate during operation. Do not joint treated lumber or anything that contains harmful chemicals, as this will spread wood dusts that contain such harmful chemicals. Do not attempt to joint workpiece with loose knots or with any other foreign materials.
2. **CHECK CUTTER INSERTS:** Make sure cutter inserts are sharp, clean, and free from damages. Forcing dull/damaged cutter inserts to work invites accidents, and lowers the quality of the finish. Use recommended amount of torque to securely fasten all inserts onto the cutterhead.
3. **SERVICING CUTTER INSERTS:** Wear heavy duty leather gloves to protect your hands when installing new cutter inserts or rotating the existing ones. Ensure the cutterhead is thoroughly clean before installing the insert. Debris between the cutter insert and the platform can create uneven pressure, causing the insert to break, and body injuries may occur.
4. **CHECK CUTTERHEAD GUARD:** Make sure the cutterhead guard is installed and is properly tensioned. The cutterhead guard should spring back and push against the fence, after it is rotated away and released.
5. **CHECK OUTFEED TABLE HEIGHT AND ALIGNMENT** to avoid a workpiece getting stuck while feeding.
6. **CHECK DEPTH OF CUT SETTING.** Maximum depth of cut for each pass is 1/8".
7. **SUPPORT LONG WORKPIECE** with auxiliary stock feeding rollers/tables. This will help avoiding injuries and improve quality of finish.

When Jointing:

1. **DUST COLLECTION SYSTEM** is required for this jointer. Please make sure the system is on and provide enough suction before operation begins.
2. **KICKBACK** happens when a workpiece is ejected at high speed during operation. Kickback projectiles can cause serious injuries or even death. Sudden movement of workpiece from kickback can also cause hands or other body parts getting pulled into the cutterhead. Operator should be cautious at all times about possible kickback.
3. **PROPER STOCK FEEDING** reduces chance of kickback. NEVER start the machine with anything engaging the cutterhead. NEVER start feeding until the jointer has reached its full speed. Use the right amount of downward pressure and forward force for feeding.
4. **INSPECT WORKPIECE.** Ensure workpiece is free from nails, loose knots and another foreign material. Use metal detector to scan for metal objects as appropriate.
5. **NEVER** join material shorter than 12", thinner than 1/2", or narrower than 2".
6. **NEVER** rabbet material with width or thickness less than 3/4", or shorter than 12".
7. **FOLLOW THE 3-INCH RULE.** Always use push blocks when jointing materials less than 3" in thickness or width. Keep your hands at least three inches away from cutterhead at all times when machine is running.
8. **CUPPED WORKPIECE** should be jointed with the cupped side facing down. This prevents the workpiece from rocking.
9. **PAY ATTENTION TO GRAIN DIRECTION.** Always cut WITH grain whenever possible. Jointing against or across grain, or jointing end grain increase chance of tear out and kickback.

After Operation

1. **STOP THE MACHINE** if the operator leaves the machine for any reason.
2. **WAIT** until the machine comes to a complete stop.
3. **CLEAN UP** and **LOCK POWER SWITCH** before departure.

Electricals



WARNING All electrical work must be done by a qualified electrician, and must meet the electrical code in your area.

Minimum Circuit Size Required for Model 4275 Jointer

Stock Number	Minimum Circuit Size Required
4275.101.4S	30A
4275.102.4S	30A

Please ensure the electrical circuit for this machine meets the minimum circuit size requirement. Minimum circuit size requirement applies to a dedicated circuit which provides power to one 4275 Jointer. If more machines are sharing the same circuit, consult a qualified electrician to ensure the designated circuit is properly sized for safe operation.

If a circuit is available, but not meeting the minimum circuit size requirement listed above, a new circuit must be installed for this machine.

Grounding



WARNING Improper grounding can cause electric shock, fire, and equipment damage.

Proper grounding reduces the risk to the operator in the event of electrical malfunction or breakdown. This machine must be connected to the grounding conductor when available, and all grounding connections must meet or exceed the electrical code requirements in your area. Furthermore, all grounds must be verified and must meet or exceed the electrical requirement of the machine. If grounding is not available, consider the use of a GFCI protection device as an alternative, if this complies with the electric code in your area.

Electrical Wiring

This machine is not pre-wired with a cord and a plug. If you plan to connect the machine directly to the electrical panel (“Hardwiring”). Please ensure there is a readily accessible electrical disconnect near the machine. Refer to section “Wiring Diagram” for wiring your machine to a power source.

If you choose to connect this machine with a plug and a cord, please use a UL/CSA listed plug. If you need an extension cord to connect to the power outlet, select a durable cord type with high temperature rating (90C° or above). Both plug and power cord must be sized to meet the amperage requirement of your machine.



Minimum cord size (AWG) required based on amperage draw and length of the cord:

Amps	Power Cord Length				
	25 feet	50 feet	75 feet	100 feet	> 100 feet
< 5	16	14	14	14	NR
5 to 8	14	14	14	12	
8 to 12	14	14	12	10	
12 to 15	12	12	10	10	
15 to 20	10	10	10	NR	
21 to 30	10	NR	NR	NR	

*NR: Not Recommended

 WARNING	<p>Use properly sized wires that meet or exceed the power requirement of your machine. Using undersized wires may cause overheating and increase the risk of fire and machine damage.</p>
---	--

 WARNING	<p>Improper copper-aluminum wire connection is a fire hazard. If the power circuit available uses aluminum wires, use certified CU/AL wire connectors.</p>
---	---

Setup

Shop Preparation

Space Requirement

The dimensions of this machine are 100”(L) x 42”(W). You will need additional spaces for manipulating your workpiece, electrical connection and dust collection.

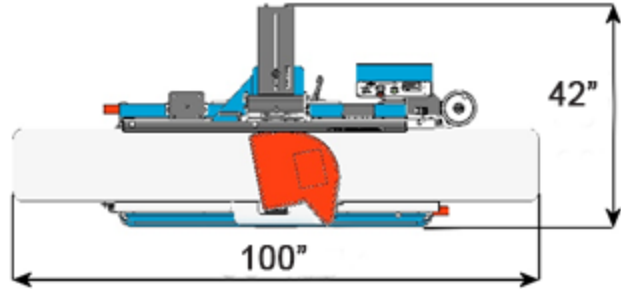

Load Limits

This machine has a shipping weight of 1,136 lbs., and a net weight of 1,099 lbs. Please ensure all lifting tools and building structures have adequate load capacity, for transporting and supporting the total weight of this machine, the operator, and related items.

Electricals

Ensure a properly sized circuit and an electrical terminal are available nearby the machine. If the machine is to be hardwired, there must be a readily accessible power disconnect nearby, so that the machine can be disconnected from power source for servicing and adjustments. If the machine is to be connected with a cord and a plug, please ensure a matching outlet is installed nearby the machine.

Please refer to section “Electricals” in this manual for details regarding electrical requirements.

Lighting

Adequate lighting is needed for operating this machine. Overhead, non-glare lighting should be installed.

Safety Labels

If this machine introduces a new safety hazard to your work place, display proper warning signs in highly visible location(s).

Dust Collection

Wood dusts created by this jointer is a health hazard. Connect a dust collection system to this machine. Check air suction regularly to ensure the pipes are not jammed.

Dust masks should be available for using the jointer.



CAUTION

Use a dust collection system that is rated above 700 CFM. Doing so improves air quality in the workplace, and protects the machine from jamming.

Piping of dust collection system introduces additional air resistance, and decreases the effective CFM measured at the dust ports. Ensure there is significant suction at the dust port, so dust and debris can be effectively removed from the machine.

Receiving

Your shipment should come with one wood crate. Upon receiving your shipment, check for any significant damages before signing the delivery confirmation.

IMPORTANT

If items are damaged, please call us immediately at **1-800-559-5065**

Moving Machine into the Shop

Your machine will be delivered by freight service, and it will be left outside of your workshop by default. On the day of delivery, please be sure help is available to move the machine to its final location.



4275 Jointer has a gross weight of 1,136 lbs. and a net weight of 1,099 lbs.

Safe moving techniques and proper lifting equipment required, or serious personal injury may occur.



Your shipment may be secured by the straps. Do not lift your shipment by the strap. They are not designed to hold the total weight of your shipment. They may snap without warning and cause serious injury and machine damage.

Always wear safety goggles and gloves when removing straps, as they may spring back violently when released and cause injury.

Unboxing

Upon removing the crate cover, you should find a jointer that is mostly assembled, and two paper boxes that contain all loose parts and accessories. Everything is covered by a plastic bag.



Inventory

Carefully unwrap the packaging and make sure all components are included in the shipment. Lay out all items received and inventory them.

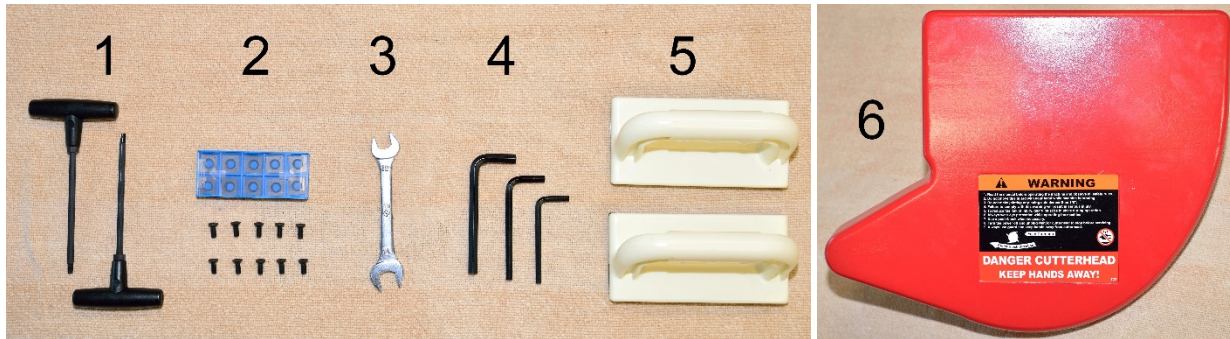

Item	Description	Quantity
1	T-Handle Torx drivers (T-25)	2
2	Spare Cutter Inserts and Torx Screws	10 each
3	12/14 mm Combination Wrench	1
4	Metric hex wrench set (5,6,8 mm)	1 each
5	Push blocks	2
6	Cutterhead guard	1

NOTICE: If you cannot find the item in the list above, please check if they are still attached to the packaging or inside the cabinet. Occasionally the item may have been pre-installed at the factory. Please refer to the parts list section in this manual to ensure you have all the components to set up this machine.

NOTICE: This machine comes with various standard sized, non-proprietary parts. If any of these parts are missing, we be happy to deliver them to you. To have the machine up and running as soon as possible, you can also find these parts at your local hardware store.

Additional Items Recommended for Machine Setup

Item	Purpose
Safety Glasses	Protection
Disposable Gloves	Protection
Paper Towel / Rags	Cleaning
Rust Inhibitor	Cast iron rust protection.
Straight edge	Check alignments.
Metric Combination Wrench Set	Assembly and Maintenance
Metric Hex Wrench Set	Assembly and Maintenance
Torque Wrench	Cutter inserts installation and for checking Torx screw tension (52-60 lbs.-inch).
T25 Star Bit Socket	Cutter inserts installation.
Ring Terminal Connector and Crimping Tool	Connecting machine to power. IMPORTANT: Always follow local electrical code for electrical work.

Removing Machine from Crate

When all items are ready for machine setup, attach lifting sling to the lifting hooks located at the two corners of the cabinet. Gently lift machine up from the pallet and move to its final location.

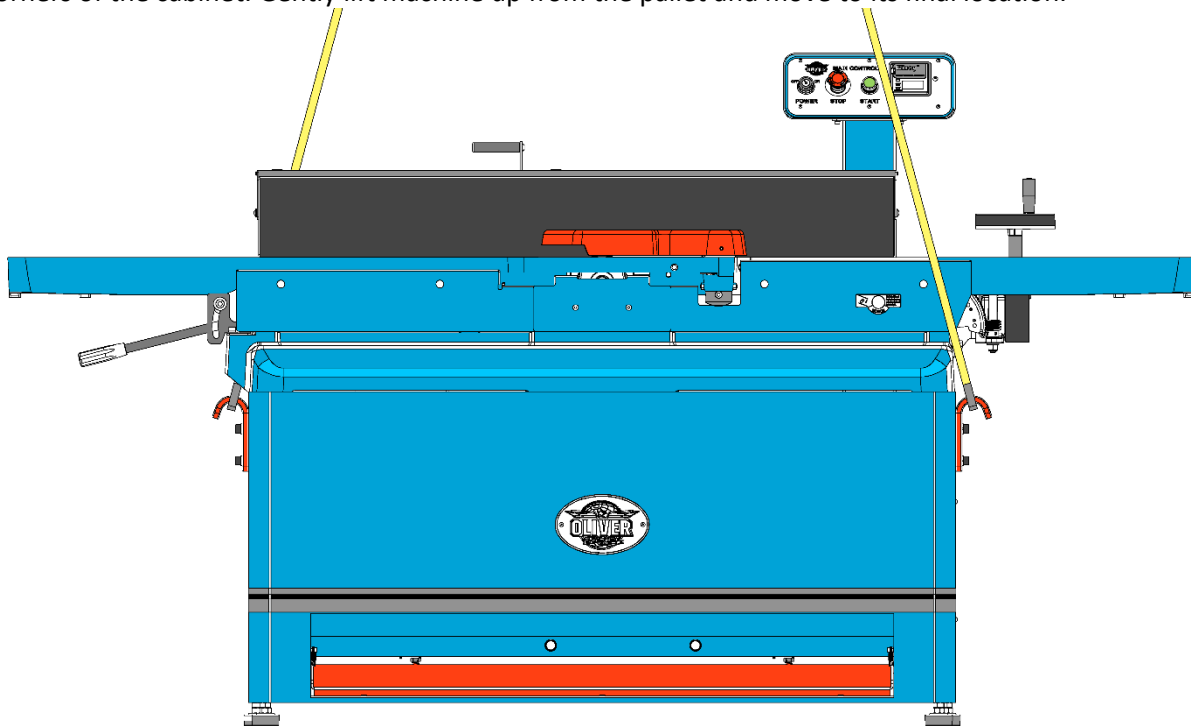

WARNING

4275 Jointer has a net weight of 1,099 lbs. All lifting devices must be capable to handle the load, or serious personal injury and machine damage may occur.

Cleaning

To prevent rusting, the cast iron jointer tables are covered with machine oil and plastic film. Remove the plastic film, then wipe off the machine oil with paper towels or rags.

Once all the machine oil is removed, routinely coat the unpainted cast iron surface with rust preventive such as Boeshield® T-9 or paste wax. Do not use rust preventives that contains silicon, which is known to interfere with certain finishes and glues.



Assembly

This jointer is mostly assembled in the factory. There are a few more steps to complete before the machine is ready for a test run:

1. Setup control panel.
2. Install battery for digital readout.
3. Inspect / Adjust Jointer Tables (optional).
4. Install cutterhead guard.
5. Connect jointer to a dust collection system.
6. Connect jointer to power source.

The approximate time for cleaning and assembly is approximately 60 minutes.

Setup Control Panel

1. To prevent damages, the control panel is lowered when it is shipped from the factory. Please follow the instructions to setup the control panel:

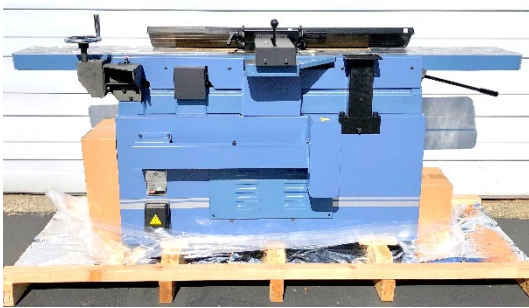

2. Remove all six cap screws from control panel post.

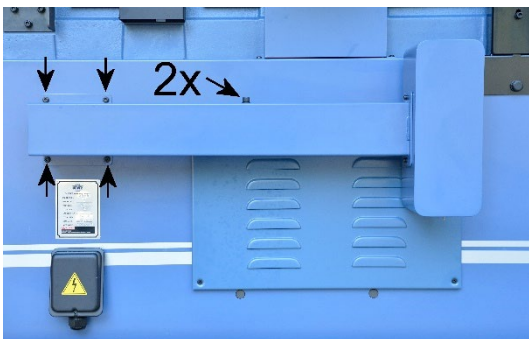

3. Raise the control panel to its operational position, then remount it back to the cabinet.

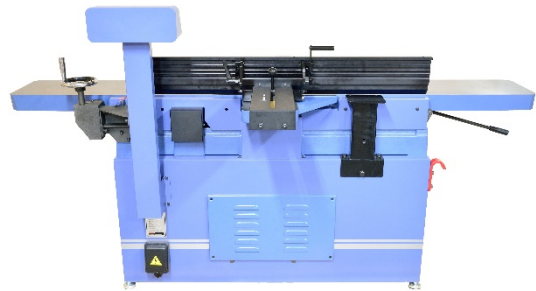

4. Attach the last two cap screws through the table adjustment handwheel bracket.

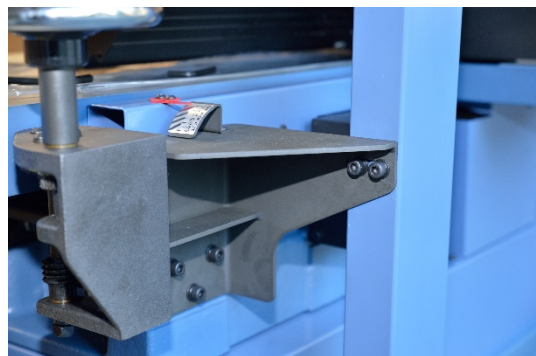

Install Batteries for Digital Readout

Locate the digital readout on the control panel. Remove the battery cover and install 2 AA sized batteries.

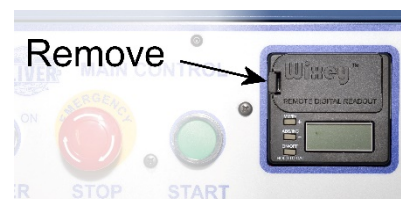

Inspect / Adjust Joints Tables (Optional)

Refer to section "Maintenance -> Inspect / Adjust Joints Tables"

Install Cutterhead Guard

1. Insert cutterhead guard shaft into the hole on the rabbeting table.

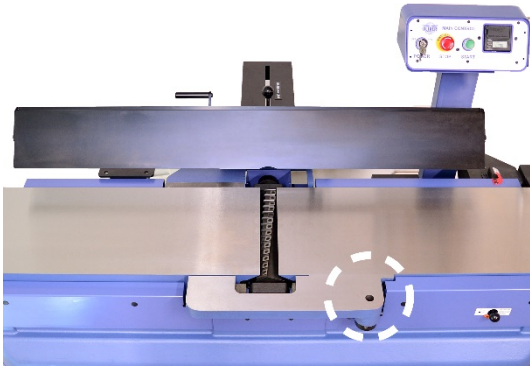

2. The guard must be installed as low as possible without scratching the table.

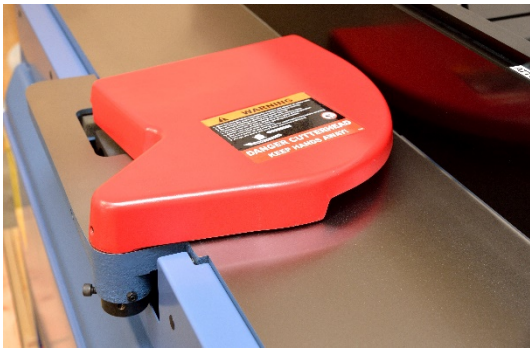

3. There is a spring-loaded knob at the bottom of the rabbeting table. It has a cap screw which grabs the cutterhead guard shaft and keeps the guard pushing against the fence.

Rotate the knob anticlockwise until you can feel the tension from the spring, then rotate it for another 1/3 turn. Hold the knob in position and tighten the cap screw.

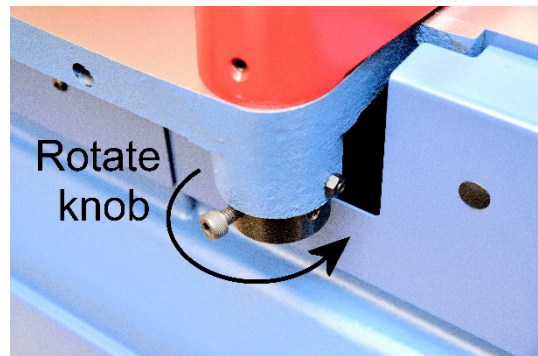

NOTICE: There are four screw holes on the knob. If the cap screw gets in the way while the knob rotates, relocate the screw and tighten when the knob is rotated to the proper position.



WARNING

Always operate this jointer with a cutterhead guard, except for some rabbeting operations. Serious personal injury may occur when operating a jointer without cutterhead guard.

Leveling Machine

This jointer should be positioned on level, stable floor. If machine is rocking on the floor, or if it vibrates excessively during operation, please adjust the rubber feet to level the machine:

1. Loosen the jam nut to unlock leveling foot.
2. Rotating the leveling foot to adjust its height.
3. Make adjustments on all other leveling feet until machine is completely leveled.
4. Tighten jam nuts of all adjusted leveling feet.

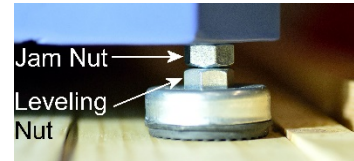

Dust Collection

Jointer can generate a lot of wood shavings and dusts. Connect dust collection system to this machine.

Minimum CFM requirement for this jointer is 700 CFM at the dust port, which means your dust collection system should have a rating greater than 700 CFM, as air friction from the ducts reduces effective CFM at dust ports.

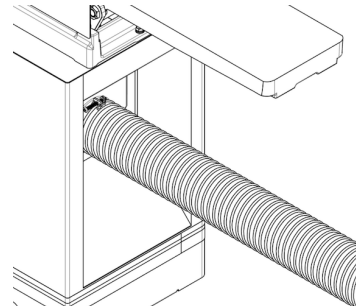

IMPORTANT

Running this jointer without dust collection system, or using a dust collection system with inadequate suction, will cause dust and shavings to accumulate inside the jointer. This can damage the machine and cause other hazardous situations. Check your dust collection system regularly to make sure it is not jammed or filled up.

Wiring and Grounding



Deenergize the electrical circuit before touching any enclosed, electrified parts. Touching electrified part WILL result in serious personal injury or death.



WARNING

All electrical work must be done by a qualified electrician, and must meet the electrical code in your area.

Make sure voltage of your power circuit matches the power requirement of this machine, and the circuit is sized to supply power to the jointer.

Wiring Instructions

1. **Power off before connecting any wires!!**
2. Remove the screw that secures junction box cover.

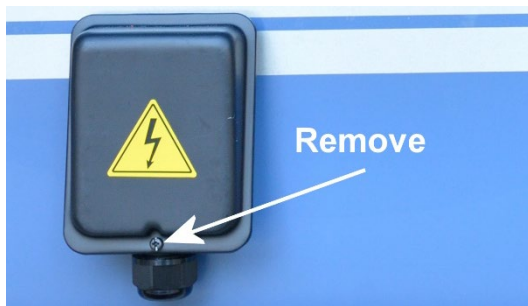

3. The wire connector inside the junction box accepts hot conductors with ring/spade terminals. The ground conductor can be connected with wire nut.



4. Insert power cord through strain relief. The strain relief can be temporarily removed from junction box to make this task easier.

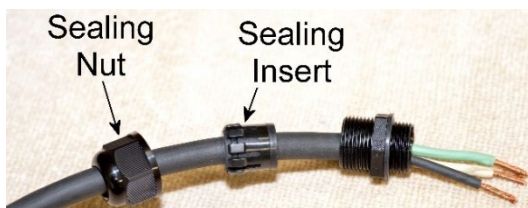

5. The picture below shows an example of how a single phase 230V model can be connected to a power source with ring terminal.

Please refer to the section "Wiring Diagram" for connecting a specific model to power source.



IMPORTANT: Always refer to local electrical code for properly connecting any machinery to power source.

6. Hand tighten sealing nut of the strain relief to keep the cord in place.
7. Re-install junction box cover.

Controls and Components

Control Panel



Key-Operated Main Switch

This switch enables access control to the jointer. To restrict access, lock the switch at “OFF” position. Machine’s power will be cut off.

Stop Button with Emergency Reset

This stop button is equipped with emergency shutoff feature. When it is pressed, the machine will stop, and the stop button will need to be reset before the machine can start again. To reset, simply rotate the rim with serrated edge. The button will pop up when it is reset.

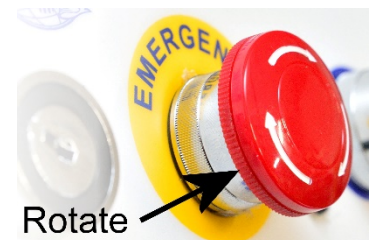

Start Button

When this machine is unlocked and the emergency stop button is reset, press START will start the machine.

Infeed Table Height Adjustment Handwheel and Depth Scale

The infeed table height adjustment handwheel is located right below the control panel:

- Turn **CLOCKWISE** to raise the table.
- Turn **COUNTERCLOCKWISE** to lower the table.



The depth of cut scale next to the handwheel indicates the position of the infeed table.



Infeed Table Depth Stop Knob

As a safety feature, a depth stop is set up to prevent depth of cut goes beyond 1/8" for jointing operations. To get more than 1/8" depth of cut for rabbeting operations, pull and hold the knob when lowering the infeed table.



The fence can be retracted and raised above the table to provide additional clearance for servicing the cutterhead.

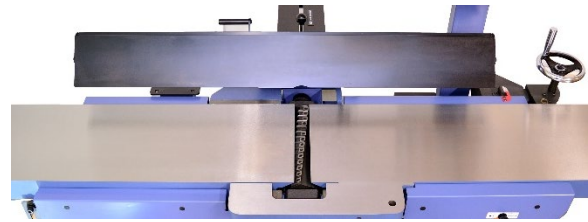

This fence comes with an auxiliary fence for jointing thin stock. When not in used, it can be securely hung on top of the main fence with the fence hanging notch.

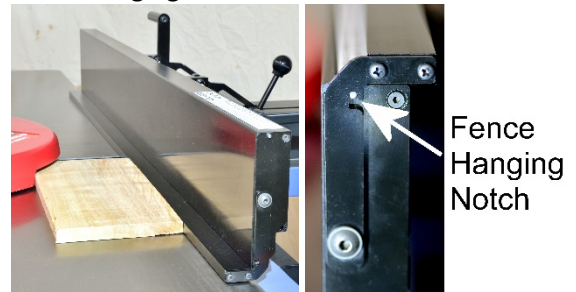

Outfeed Table Height Lever and Lock

The outfeed table height adjustment lever is located below the outfeed table. The outfeed table height is locked by a locking cap screw.

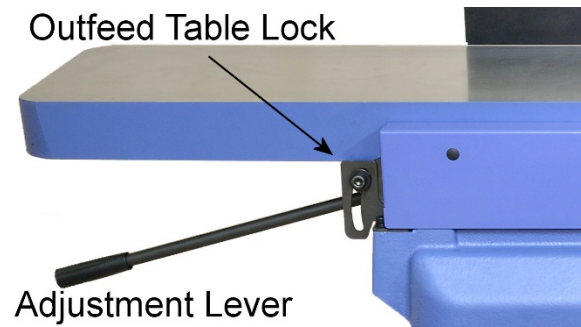

IMPORTANT: When deploying the auxiliary fence, please be sure the plastic supporting plates are sitting between the auxiliary fence and the table. Without these plates, the cutterhead will strike the auxiliary fence.



Fence

This extruded aluminum fence has two adjustable positive stops at 45° and 90°.

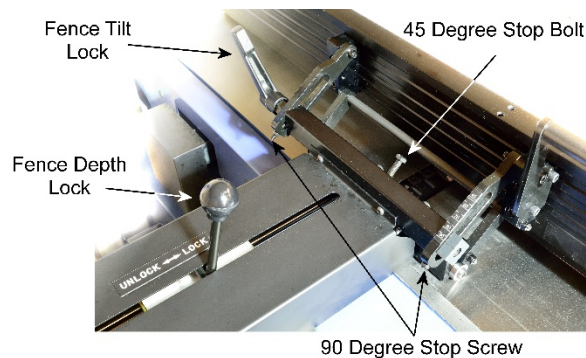

Digital Readout (DRO)

This jointer is equipped with a Wixey DRO with 0.005"/0.05mm resolution.



On/Off Button

To turn on/off this DRO. It is also for calibration in ABS (absolute) mode.

MM/IN Button

Toggles between inch and mm as measurement unit. When the reading gets close to a multiple of 1/32, its fractional value will show on the screen.

ABS/INC Button

Toggles between **Absolute** and **Incremental** mode.

Absolute mode shows total depth of cut. Once calibrated, settings will be memorized unless the battery is exhausted, OR if user recalibrates the DRO.

Incremental mode shows distance infeed table travelled since the last reset. The readings can be reset by leaving incremental mode.

DRO Calibration

1. **Disconnect jointer from power source!!**
2. Set infeed table depth of cut to zero.
3. Turn on DRO and switch to ABS mode.
4. Hold ON/OFF button for 3-5 seconds until "ABS" is blinking on display. As the button is released, readings will be reset to zero.
5. Press ON/OFF button again to leave calibration mode.

Test Run

Each jointer has been inspected and calibrated before leaving the factory to meet our quality and precision standards. Due to various reasons, this jointer may need to be re-adjusted when it arrives at your workshop. It is recommended to complete this test run before using the jointer for production work, and repeat if the jointer is relocated.

Complete these quick tests to verify components are functional.

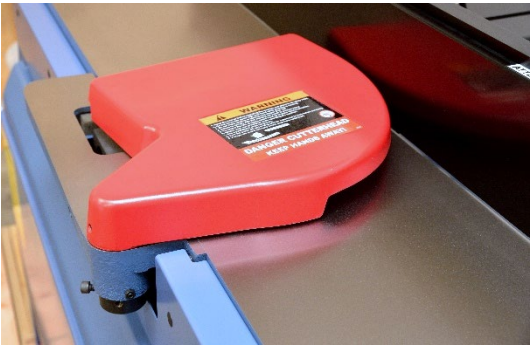
1. Remove all tools and debris from the machine. Ensure machine is disconnected from power source.
 2. Move and lock the fence all the way back to expose the entire jointer table. Ensure cutterhead guard is pushing against the fence. Rotate the guard to expose the entire cutterhead, then release the guard. The cutterhead guard should rotate back to its original position.
- 
- The image shows a red emergency stop button mounted on a machine. The button is shaped like a hand with the index finger pointing towards the center. It has a yellow label with black text that reads 'EMERGENCY STOP' and 'PRESS HERE TO STOP THE MACHINE'. The button is located on a blue metal frame.
- WARNING: If cutterhead guard needs adjustment, STOP HERE. Have the guard adjusted before resuming the test run.**
3. Use the provided key to turn main switch to OFF position, and press emergency STOP button.
 4. Connect machine to the power source.
 5. Press START button. The machine should not turn on.
 6. Turn main switch to ON, and press START button. The machine should not turn on.
 7. Reset the emergency STOP switch by rotating it clockwise. The button should pop up. Press START button, and the machine should turn on. The machine should be running with no excessive noise and vibration.
 8. Disconnect machine from power source while it is running, then reconnect machine to power. The machine should **NOT** restart.
 9. Turn on DRO. Rotate the infeed table adjustment handwheel to raise/lower the infeed table. DRO's readings should reflect movements of the table, and the table should stop at 1/8" when is lowered without disengaging the depth stop.
 10. Set infeed table depth of cut to 1/32".
 11. Turn on dust collection system, and surface plane a test workpiece. The workpiece should move through the jointer with ease.
 12. Inspect the workpiece for unusual tear outs and other defects.

Congratulations for completing the test run! Now your jointer is ready for production work. If you discover any issue from the tests, please refer to the troubleshooting section and maintenance section for how to diagnose the issue and make adjustments.

Operation

Preparation

For safety and best results, please take the following steps before processing any workpiece on this jointer.

Only Use Natural, Good Quality Wood

Only use this jointer for natural, quality wood materials. Cracked stock, board with loose knots, plywood and other engineered wood products can break apart and cause severe kickbacks, which can lead to severe injuries and machine damages.

Do not use this jointer to cut treated lumber or anything that contains harmful chemicals. This will spread wood dusts that contain such harmful chemicals.

Inspection

Carefully inspect workpiece for foreign objects. Nails, staples, rock chips and other objects embedded on wood surface will damage the jointer. It is advised to clean a workpiece with a stiff brush to remove all dirt and foreign objects ahead of time, especially for rough sawn or reclaimed lumber. Use metal detector to scan for metal objects as needed.

Check Dimensions

For safety, NEVER process stock that is:

1. Shorter than 12"
2. Thinner than 1/2", or
3. Less than 2" wide.

Support Long Workpiece

Support long stock with rollers or other devices to avoid injuries. This also helps creating a smooth, consistent finish.

Check Moisture Content

Check moisture content of the workpiece before operation. "Green wood" with moisture content over 20% will not cut properly and may jam the machine. Excessive moisture content will also cause jointer's unpainted surface to rust. Besides, as the workpiece dries, once-flattened surface can become fuzzy and warped again. It is recommended to allow the workpiece to dry and stabilize before it is processed.

Warped Stock

Avoid using boards with severe warping, as they can be unstable and might cause severe kickbacks during operation.

Glue Deposits

Glue left on the workpiece surface can dull the cutters and lower cut quality. Scrape off all glue deposits from the workpiece before operation.

Inspect Wood Grain

This jointer is designed to cut WITH grain. Avoid cutting against/across/end grain as severe kickback and chipping may occur.

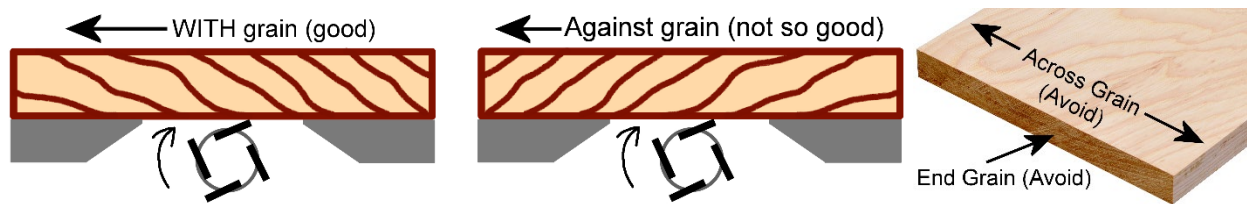

Sometimes it is impossible to cut with grain for the entire length of a workpiece. In this case, try feeding the workpiece in opposite direction and see what works best. Reducing the depth of cut and feed rate can also help improving cut quality.

Squaring Stock

Jointer is commonly used in conjunction with planer and table saw for squaring stock. Rough, warped stock is milled so it becomes flat and parallel along both length and width, and with the length and width perpendicular to one another.

It takes four steps for squaring stock:

1. Surface Planing - The bottom face of the stock is flattened by a jointer. The concaved face should be chosen for this step.
2. Thickness Planing - The top face of the stock is flattened by a thickness planer. In this step the workpiece can be planed down to the desired thickness.
3. Edge Jointing - The concaved edge is straightened and squared on a jointer.
4. The last edge is straightened with a rip cut on table saw, with the jointed edge placed against the table saw fence. In this step the workpiece can be cut to the desired width.

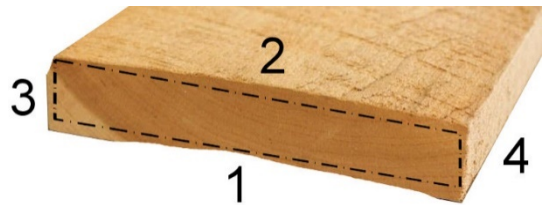

Serious injury or death can result from machine kickback or accidental contact to the cutterhead. Follow these safety rules to reduce your risks for all jointing operations:



- Begin operation with the concave, or the most stable surface for jointing.
- Feed stock with steady, controllable force. Remain stable stance and balance.
- Use eye and ear protection devices.
- Cutterhead guard must be installed for all jointing operations.
- Keep hands at least 3" away from the cutterhead.
- Use push blocks whenever possible.



Ensure dust collection system is functional and use dusk mask to avoid inhaling harmful airborne particles.

Surface Planing

1. **Inspect stock for quality issues and grain orientation prior operation.**
2. Begin surface planing with the concave face when present (see examples on the right).
3. Adjust depth of cut of infeed table. Do not cut more than 1/16" per pass to allow control over the workpiece.
4. Set fence to 90°.
5. Start jointer and dust collection system.

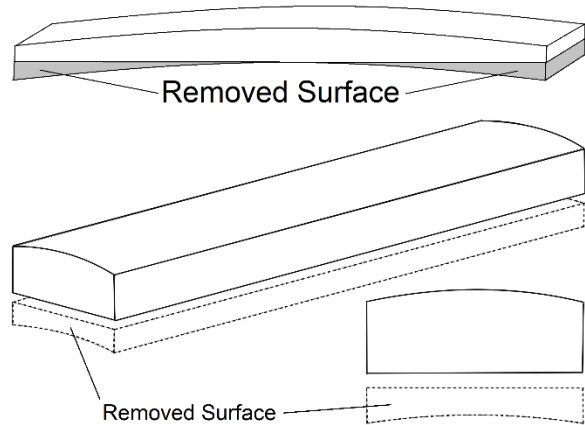

6. To initiate a cut, stand near the infeed table, slightly behind the cutterhead. Use left hand to push firmly on stock against the fence and infeed table, and use right hand to feed the stock from the back. Use push blocks whenever permissible.

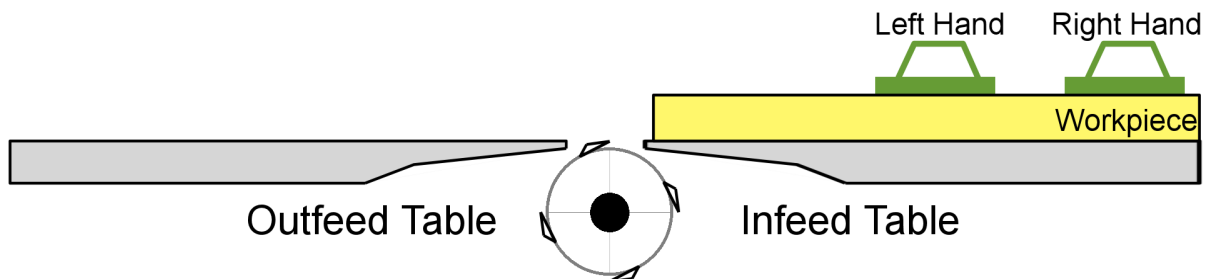

7. Feed a small section of stock across the cutterhead with pressure against the fence and the infeed table.

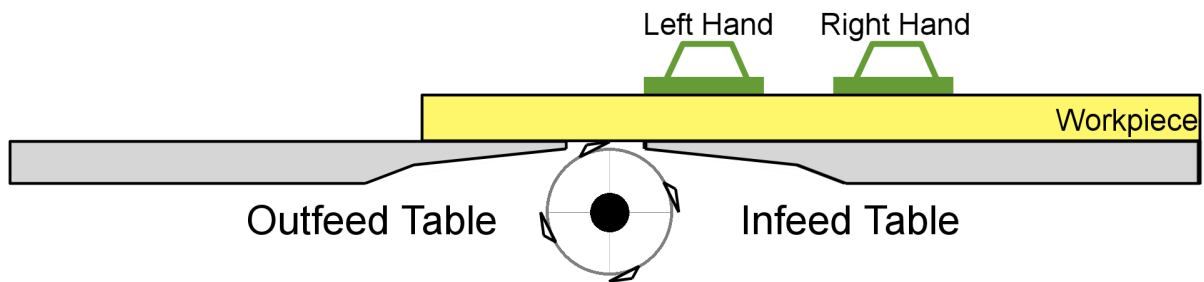

8. As left hand approaches the cutterhead, lift it up and move across the cutterhead to avoid accidental contact. Put left hand on stock that sits on the outfeed table, and continue to feed. Maintain control of stock with right hand while repositioning left hand.

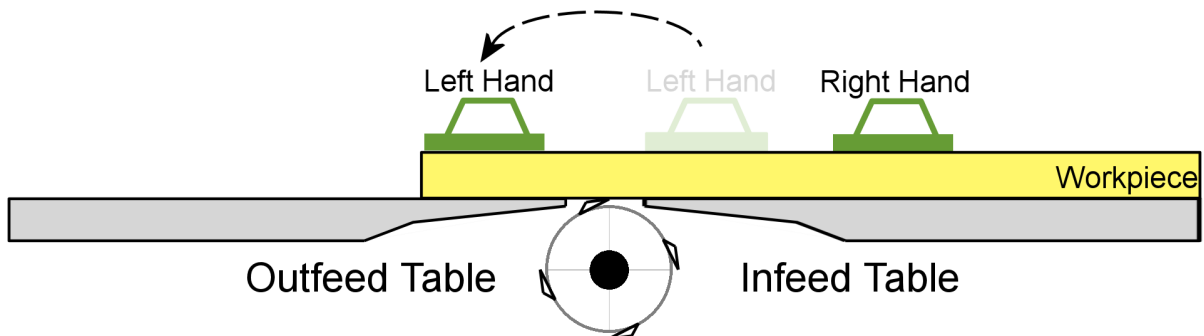

- As the right hand approaches the cutterhead, reposition right hand as shown in the diagram. Operator should move forward and continue feeding next to the outfeed table. Maintain control of stock with left hand while repositioning right hand.

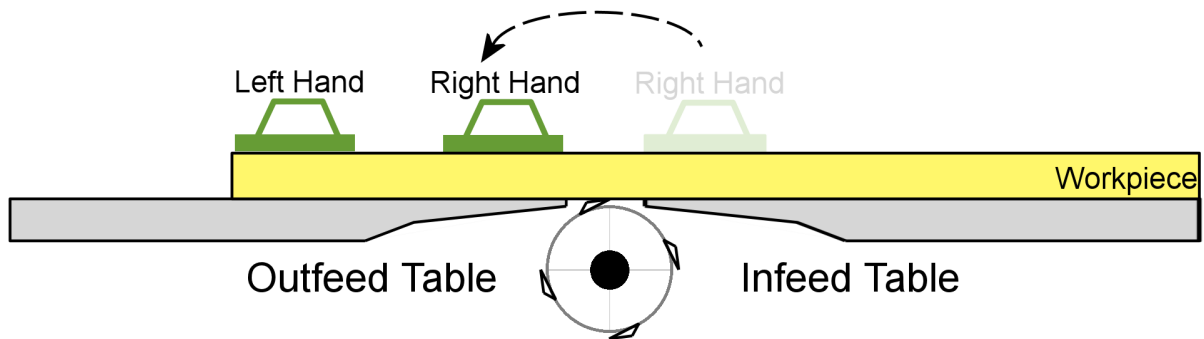

- From this point on, continue feeding only on outfeed table until the entire length of stock has moved across the cutterhead. Maintain feed rate to produce smooth cut with no burnt marks.

NOTICE: Putting downward pressure on the infeed table is unnecessary in this stage, and may cause the stock to bow, taper or snipe at the end.

- Repeat steps 6-10 until the entire surface is cut flat.

TIP: For new jointer users, practice stock feeding with depth of cut set to 0". This helps perfecting the skills before actual operations.

TIP: To ensure the entire surface is cut, some woodworkers leave pencil marks on the entire length of stock before the final passes, then verify all marks are removed after a pass.

TIP: For thin stock, avoid excessive downward pressure which will flatten any cup or warp as the stock pass through the cutterhead. After pressure is released, the cup or warp will spring back. Only apply adequate pressure to maintain control of the stock when feeding.

Edge Jointing

1. **Inspect stock for quality issues and grain orientation prior operation.**
2. Begin edge jointing with the concave edge when present.

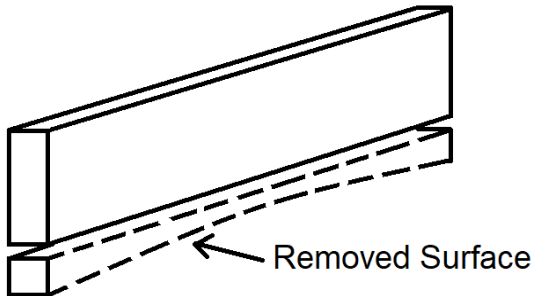

3. Set depth of the cut to the minimum amount to obtain a straight edge. Do not set cuts deeper than $1/8''$ in a single pass.
4. Set fence to 90° .
5. Start jointer and dust collection system.
6. Hold the best flattened face of the workpiece firmly against the fence throughout the entire cut. Use push blocks whenever permissible.



7. Follow steps [6-10] in "Surface Planing" for feeding stock through the jointer. Repeat the process until the entire edge is jointed flat and square.

Beveling

Instructions and precautions for edge jointing applies to beveling except:

- Instead of setting the fence to 90° , set fence tilt to the desired angle of cut using a protractor.
- Reduce depth of cut to $1/16''$ - $1/8''$ based on the width of bevel, and hardness of the workpiece.

Rabbet Cutting

A rabbet is a groove cut along the edge of a workpiece. This jointer is capable of making rabbet cuts as deep as 3/4", and with width as little as 5/16". Depends on the requirements and constraints of your project, a jointer, or other tools such as table saw, router or other hand tools, can be the best tool for your rabbeting needs. Always consider safety when choosing a tool for rabbeting.

Performing a rabbeting cut with this jointer may require the cutterhead guard removed. Promptly re-install the guard after rabbeting operation completes.

1. **Inspect stock for quality issues prior operation. The surfaces for rabbeting must be flat and squared.**
2. Set fence to 90°
3. Slide fence forward to set the width of cut. The amount of exposed cutterhead is the width of the rabbet. With the main fence, the minimum width of cut is 1-7/16". Using the auxiliary fence can further reduce the width of cut to 5/16".
4. Remove the cutterhead guard as needed.
5. Lower the infeed table to the desired depth of cut for each pass. Disengage the infeed table depth stop as the infeed table travels below 1/8". Maximum depth of cut for rabbeting is 3/4".
CAUTION: For safety, never exceed 1/8" per pass.
6. Start jointer and dust collection system.
7. Place workpiece firmly against the fence, infeed table and rabbeting table. Use push blocks whenever permissible.
8. Feed the workpiece through completely across cutterhead while keeping it firmly against fence and tables during the entire cut.



CAUTION: Beware that the rabbeting table is short and narrow. Take extra caution and maintain support of the entire workpiece throughout the operation.



If cutterhead guard is removed for rabbeting operation, use extreme caution when performing cuts. Reinstall the guard immediately when operation completes.

Common Cutting Problems

Snipe

Occurs when too much pressure is applied as a workpiece enters or leaves the cutterhead. This can also cause by improper table settings.

To mitigate this problem, apply even feeding pressure throughout the entire workpiece. Once the workpiece is past the cutterhead, downward pressure should be focused on the outfeed table only. Ensure outfeed table is not positioned way below the cutter head.



Chipping

Happens when making a cut against the grain direction. For highly figured lumber, and areas near a knot, some amount of chipping is normal. In this case, moistening the problematic area before jointing can sometimes mitigate the issue.

Chipping can also cause by dirty or dull cutters. If chipping happens while planing straight grain stocks. Inspect the cutter inserts and remove all resin buildups. Rotate/replace dull cutter inserts when they are dull.



Fuzzy Grain

Can happen when planing wood with high moisture content or if the cutter is dull. Sometimes fuzzy grain is unavoidable due to the nature of certain wood types. To mitigate this issue, avoid using wood with high moisture content and use sharp cutters.

Accessories

Oliver Machinery has a collection of accessories and add-ons to enhance productivity of your jointer. To purchase these items, please call us at **1-800-559-5065**, our representatives are available Monday through Friday, 9AM - 5PM pacific time.

You may also purchase them online: WWW.OLIVERMACHINERY.NET/ACCESSORIES or
E-mail our parts department: PARTS@OLIVERMACHINERY.NET

460V Conversion Kit



This 460V Conversion kit allows you to convert a three-phase model (**4275.102.4S**) that is pre-wired to 230V to operate on 460V. Installation of this kit should be done by qualified electrician. You may also order the 460V three-phase model directly from Oliver Machinery. We can pre-install this kit for you.

Parts number:

491192-000 440V Magnetic Contactor
490717-000 440V Overload RA-20

Cutter Inserts



Genuine four-sided indexable carbide cutter insert that will fit the cutterhead of Oliver **4275 Jointer**. Made in Germany.

Parts number: **P-15mm 4S**

Touchup Paint



Keeping all painted surface in good condition not only keeps your machine looks nice, it keeps rusts away. We have pre-mixed spray paint available in Oliver-Blue for purchase.



Using unapproved accessories may cause machine to malfunction, resulting in serious injury and/or machine damage. Only use accessories recommended for this machine.

Power Feeder

Two models of power feeder are available for 4275 Joints. They can be installed on the power feeder mount located behind outfeed table.



Features

- Polyurethane covered rollers provide excellent grip while protecting the work surface.
- Eight feed speeds and choice of three or four rollers to fit any application.
- Versatile stand allows adjustment of 10" in height and 18" in reach.
- Powerful TEFC motor available in single or three-phase.
- CSA Listed



Model	APF0038
Stock Number	APF0038.001 1HP, 1Ph, 230V (4.2A)
Stock Number	APF0038.002 1HP, 3Ph, 230V (3.4A)
Number of Rollers	3
Roller Size	4-3/4"(D) x 2-3/8"(W)
Feed Speed	8 Speeds: 6.5 / 13 / 18 / 22 / 36 / 43 / 55 / 108 FPM
Net Weight	137 lbs.



Model	APF0048
Stock Number	APF0048.001 1HP, 1Ph, 230V (4.2A)
Stock Number	APF0048.002 1HP, 3Ph, 230V (3.4A)
Number of Rollers	4
Roller Size	4-3/4"(D) x 2-3/8"(W)
Feed Speed	8 Speeds: 6.6 / 13 / 18 / 22 / 36 / 43 / 55 / 108 FPM
Net Weight	146 lbs.

Please visit our website at WWW.OLIVERMACHINERY.NET/ACCESSORIES for other recommended accessories.

Maintenance

Routine maintenance keeps your jointer in top shape. Please follow the maintenance schedule below, and use the maintenance record worksheet attached in the back of the manual to document all tasks completed. **NOTICE:** Maintenance schedule may vary for individual users due to different situations and safety requirements.



Disconnect machine from the power source before any maintenance work is performed. After servicing the jointer, remove all wrenches and tools before restarting the machine. Failure to comply can cause serious injury!

Maintenance Schedule

Interval	Component
Every day	Remove dust buildups from jointer and dust collection system.
	Inspect power cord for sign of aging and damages. Replace as needed.
Every week	Inspect and clean cutterhead. Remove any dust and resin accumulation.
	Inspect/rotate/replace worn cutter inserts.
	Apply rust protectant on unpainted cast iron surfaces.
	Verify infeed/outfeed tables are coplanar.
Every month	Check V-belt tension and replace if belt shows signs of cracking or glazing.
Every 6 months	Lubricate worm gears with grease.

Notice: Motor bearings are permanently sealed and lubricated, and do not require lubrication.

Inspect / Adjust Jointer Tables

Each jointer has been inspected and calibrated in factory and should not require adjustments initially. When a jointer consistently makes problematic cuts, perform these checks and make adjustments as needed.

Inspect Outfeed Table Height

1. **Disconnect jointer from power source!!**
2. Put on leather gloves.



3. Remove cutterhead guard.
4. Move fence assembly all the way back to expose the entire table.
5. Place a straight edge over the centerline the outfeed table so it hangs over the cutterhead.

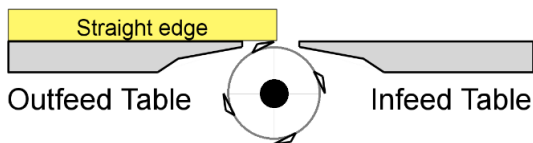

6. When outfeed table height is properly set, cutters should be barely scraping the straight edge when cutterhead rotates. Follow the next section to make adjustments as needed.

If outfeed table height is set properly, jump to section "**Inspect Outfeed Table Parallelism**".

Adjust Outfeed Table Height

1. **Disconnect jointer from power source!!**
2. Loosen the cap screw that locks the outfeed table.

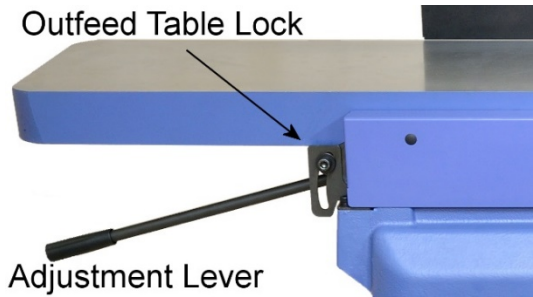

3. Adjust outfeed table height with the lever. With a straight edge sitting on the outfeed table, cutters should be barely touching the straight edge when cutterhead rotates.
4. Below the base of the lever, there are two stop bolts for setting the maximum and minimum height of the outfeed table.

If these stop bolts need to be adjusted, loosen the jam nuts, and retighten them when adjustments complete.

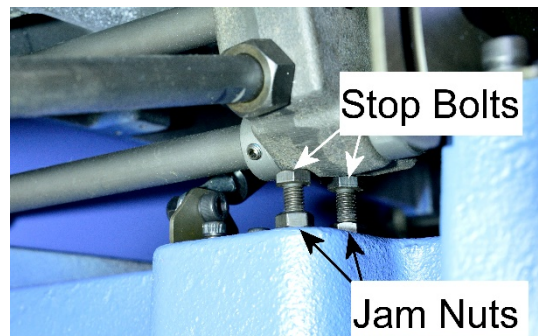

5. When height of the outfeed table is adjusted, tighten the locking cap screw to lock its height.

Inspect Outfeed Table Parallelism

1. **Disconnect jointer from power source!!**
2. Place a straight edge on outfeed table in positions as shown below:

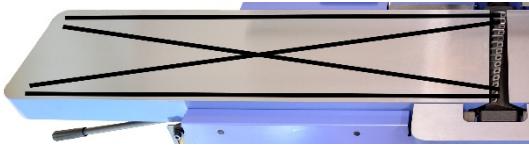

3. Make sure the straight edge is hanging above the cutterhead:

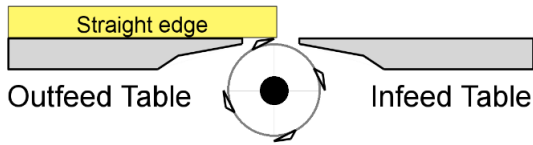

4. In each position, carefully rotate the cutterhead. When outfeed table is in parallel with cutterhead, cutters should be barely scraping the straight edge when cutterhead rotates.
5. If outfeed table and cutterhead are out of alignment, move to section “**Adjust Table Parallelism/Coplanarity**”.

If outfeed table is in parallel with cutterhead, proceed to next section “**Inspect Infeed Table**”

Inspect Infeed Table

1. **Disconnect jointer from power source!!**
2. **NOTICE:** Make sure the outfeed table is properly adjusted before continue.
3. Place a straight edge that splits evenly on both infeed and outfeed table.
4. Raise the infeed table so that it is at the same height as the outfeed table. When proper height is set, the straight edge will sit flat and flush with both infeed and outfeed table. Rotate carbide cutter away if it contacts the straight edge.
5. Move the straight edge across the tables in positions as shown in the picture below. Rotate carbide cutter away if it gets in the way.

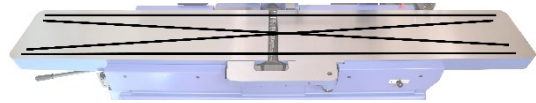

6. In each position, the straight edge should sit flat and fit flush with both infeed and outfeed tables.
7. If infeed / outfeed table are out of alignment, move to section “Adjust Table Parallelism/Coplanarity”.
8. Otherwise, congratulations! The jointer tables are well calibrated for your next project!

Adjust Table Parallelism/Coplanarity

Adjusting table parallelism and coplanarity takes time, precision and patient. The entire process can take over an hour or more. It is recommended to check the amount of misalignment against tolerance before proceed.

Measurement	Tolerance
Outfeed Table / Cutterhead Parallelism	$\leq 0.004''$
Infeed / Outfeed Table Parallelism	$\leq 0.01''$

For best results, a long and precise straight edge is required for adjustments.

1. **Disconnect jointer from power source!!**
2. Remove the depth stop knob.



3. Remove the cutterhead cover.



4. Remove all metal four metal panels that conceals the parallelogram mechanism.

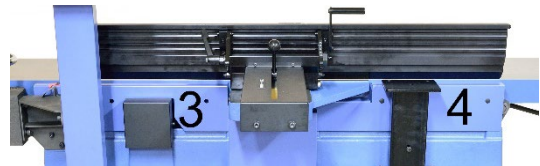

5. Each panel is secured by two cap screws, which are covered by plastic caps. Use a straight head screwdriver remove the plastic cover, then remove the hex cap screw with a 5mm hex wrench.

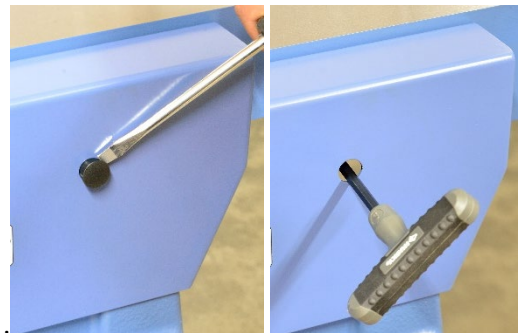

6. This picture shows the jointer with the parallelogram mechanism exposed. Table parallelism /coplanarity can be adjusted by rotating the eccentric nuts on the shafts [1-4]. There is a pair of eccentric nuts located on each end of these shafts.

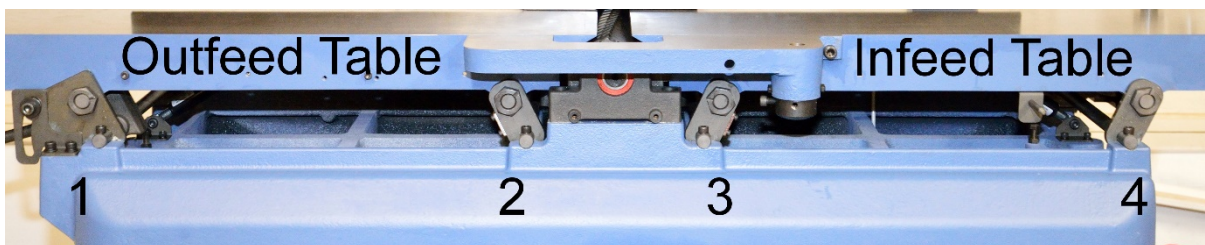

7. Locate and loosen the set screws for locking the eccentric nuts as shows in the pictures:

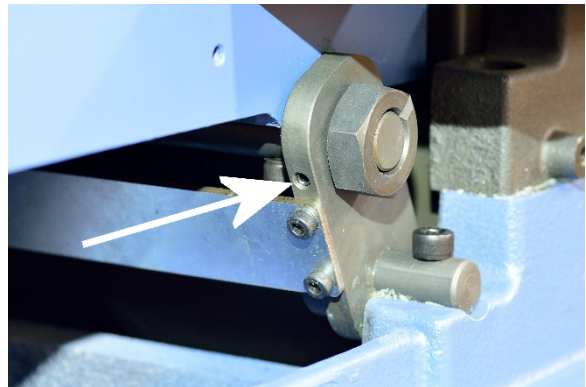
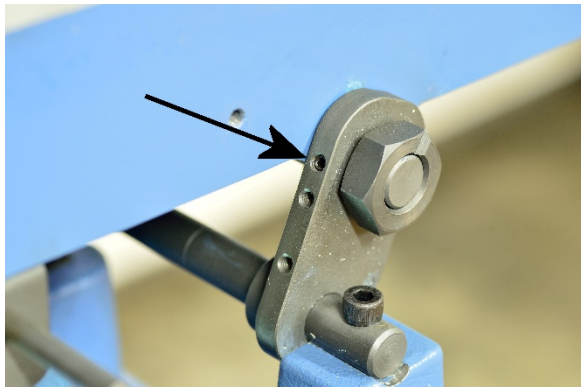
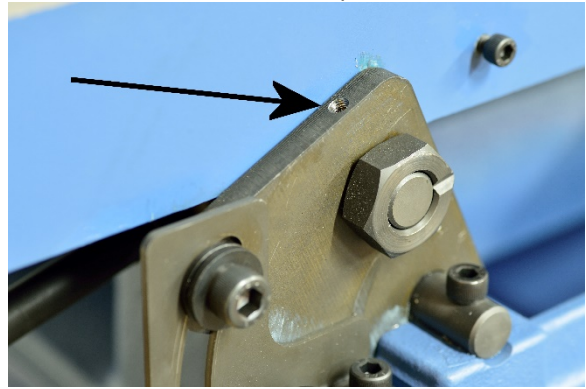
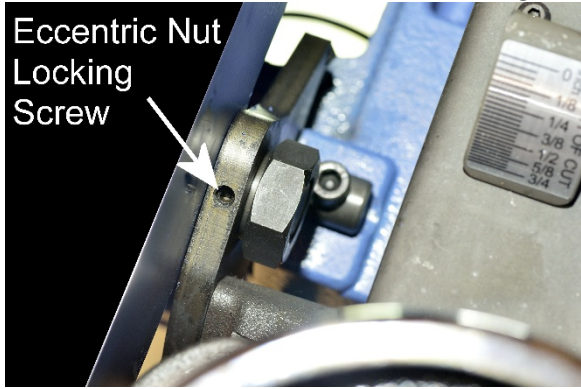

8. The eccentric nuts should be fairly loose once they are unlocked. Rotate the eccentric nuts to align outfeed table and cutterhead.
9. **IMPORTANT:** While rotating the eccentric nuts, ensure they are pushed against the holding bracket. Leaving any gaps in between may cause the table to shift sideways.

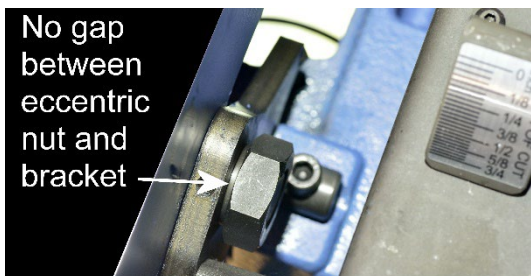

10. Repeat the steps in “**Inspect Outfeed Table Parallelism**” to verify adjustments.
11. When adjustments complete, retighten the set screws to lock all outfeed table eccentric nuts.
12. With the fence locked, gently rock the fence to ensure the outfeed table is stable. If the

outfeed table is rocking, eliminate all gaps between eccentric nuts and the bracket.

13. Adjust infeed / outfeed table parallelism using the infeed table eccentric nuts. Repeat the steps in “**Inspect Outfeed Table Parallelism**” when making adjustments. Again, leave no gaps between eccentric nut and the bracket.
14. Lock all eccentric nuts when adjustments complete.
15. With infeed table realigned, it may need additional adjustments. See section “**Infeed Table Adjustments**” for details.
16. Reinstall all panels and cutterhead guard when all adjustments complete.

Infeed Table Adjustments

After a full table realignment, the infeed table height should be re-zeroed, and a few components of the infeed table will need to be adjusted.

1. **Disconnect jointer from power source!!**
2. To re-zero infeed table height, raise the infeed table so it is approximately at the same height as cutting arc of the cutterhead.
3. Place a straight edge over the infeed table so it hangs over the cutterhead.

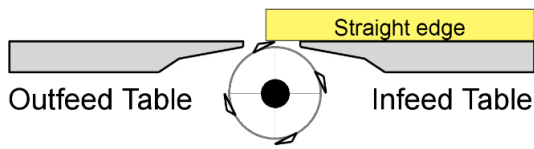

4. Fine tune table height to set depth of cut to zero. When properly set, cutters should be barely scraping the straight edge when cutterhead rotates.
5. With the infeed table height zeroed, follow the steps in **"DRO Calibration"** to re-zero the digital readout.
6. Check if the infeed table height scale is still pointing at zero. If not, loosen the 2 hex screws and readjust the pointer.



Infeed Table Depth Stops Adjustments

Under the infeed table, there are two positive stops. One is for setting maximum depth-of-cut for jointing, and another one is for making finishing passes.

1. **Disconnect jointer from power source!!**
2. With the depth stop knob left in place, attempt to lower the infeed table beyond 1/8". If this positive stop is set correctly, it will stop the table at 1/8".
3. If adjustment is needed, the stop nut is located behind the depth stop knob, which can be easily accessed when the panel is removed. Loosen the jam nuts when making adjustments.

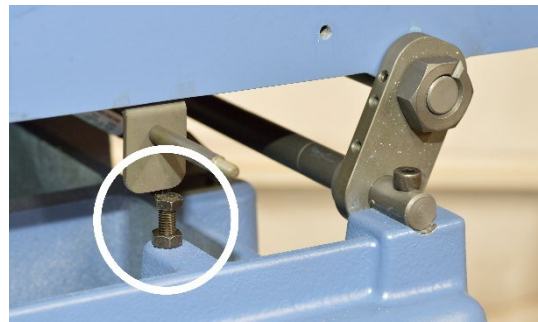

4. The stop nut for finishing passes is located below the infeed table, near the height adjustment worm gears. This stop nut should stop the table with 1/32" depth of cut. Loosen the jam nuts when making adjustments.

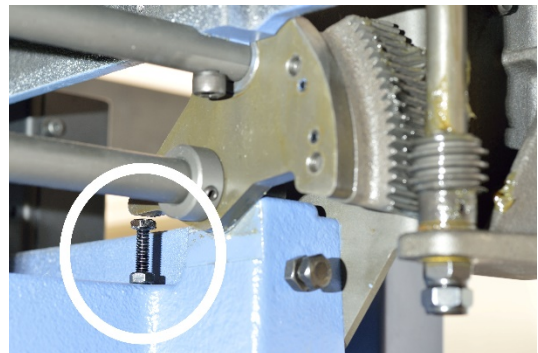

Cutterhead Maintenance

Rotate / Replace Cutter Inserts



CAUTION

Cutter inserts on the cutterhead are extremely sharp. Protect your hands with thick leather gloves to avoid injuries.

1. **Disconnect jointer from power source!!**
2. Put on leather gloves.
3. Remove cutterhead guard.
4. Move fence assembly all the way back and above the table to expose the cutterhead.
5. Remove dusts and resin accumulations on cutterhead and areas nearby.
6. Rotate cutter inserts 90° clockwise when they get dulled or nicked. Use a permanent marker to mark the new edge to be used.
7. To rotate/replace a cutter insert, remove the Torx screw with a T-25 Torx bit. Turn **COUNTERCLOCKWISE** to loosen the screw.

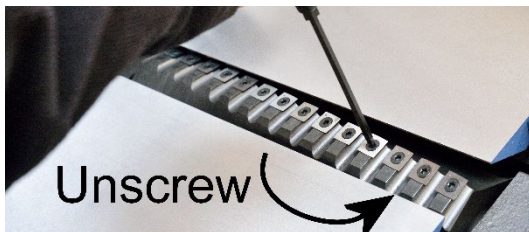

8. With the cutter insert removed from its platform, thoroughly clean the cutter insert platform with a vacuum or compressed air.

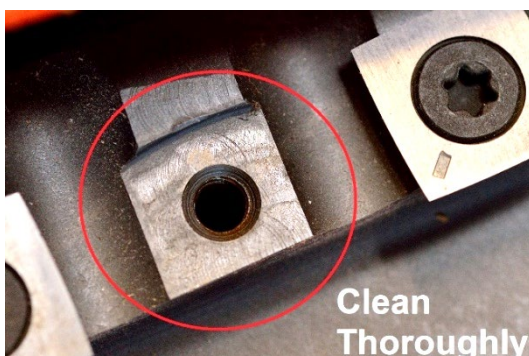

IMPORTANT: Obstacles between the insert and cutterhead platform will create uneven pressure against the insert. This will lower cut quality and may cause the insert to crack.

9. Reinstall the cutter insert with the marked cutting edge facing out.
10. Inspect the Torx screw. Replace any damaged screws. Lubricate screw thread with a thin coat of light weight machine oil.
IMPORTANT: Do not use excessive amount of lubrication, or the Torx screw and the cutter insert will not sit properly.
11. Using a torque wrench, re-tighten the Torx screw with 52-60 lbs.-inch of torque.
IMPORTANT: Do not overtighten the screw or the inserts may break. Do not use power tools to tighten the Torx screws as it can strip the screws.
12. Reinstall cutterhead guard and remove all tools from table when servicing is done.

Adjust Fence Positive Stops

The fence assembly has two positive stops at 90° and 45°. They were calibrated in factory and should not require initial adjustments.

Adjust 90° Positive Stop

1. Loosen two jam nuts and positive stop set screws.

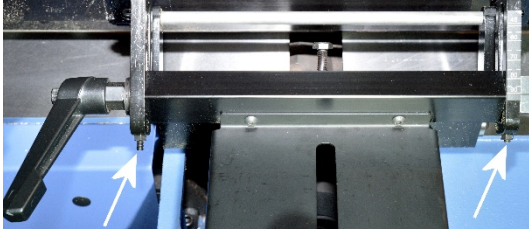

2. Use a machinist square to set the fence at 90 degrees.
3. Rotate set screws to reset the positive stop.
4. With the set screws holding in place, tighten the jam nuts.
5. Re-check fence stop settings.

Adjust 45° Positive Stop

1. Loosen jam nut and positive stop bolt.

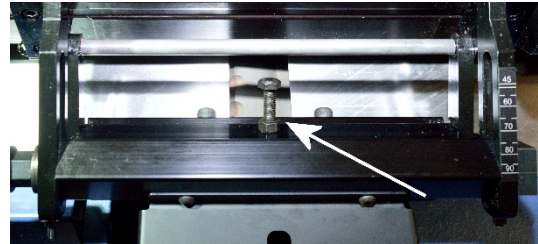

2. Use a protractor to set the fence at 45 degrees.
3. Rotate stop bolt to reset the positive stop.
4. With the stop bolt holding in place, tighten the jam nut.
5. Re-check fence stop settings.

Adjust Belt Tension



CAUTION

Belt and pulleys may be hot after operations. Allow components to cool before servicing.

1. **Disconnect jointer from power source!!**
2. Remove motor access panel and the belt cover.

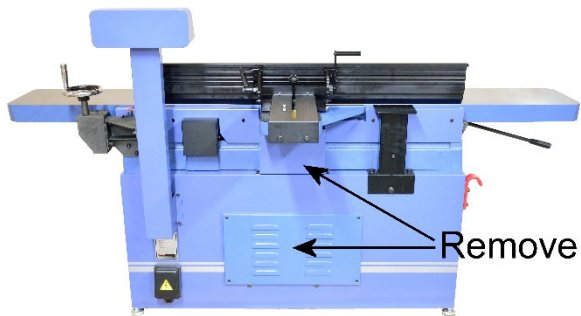

3. Apply moderate pressure on the V-belt midway between the two pulleys. Properly tensioned V-belt should deflect by approximately 1/4".

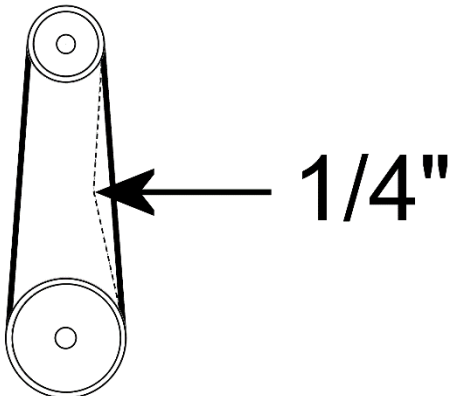

4. If V-belt tension needs to be adjusted, loosen both lower motor mounting bolts (#1). Lower the motor until proper belt tension is reached. Secure the motor mounting plate by tightening both upper mounting bolts (#2), and the lower mounting bolts.

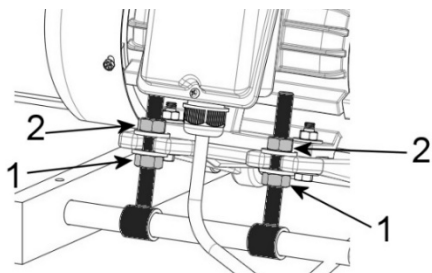

5. If V-belts need replacement, push the belt towards the motor to walk the belt out from the motor pulley.

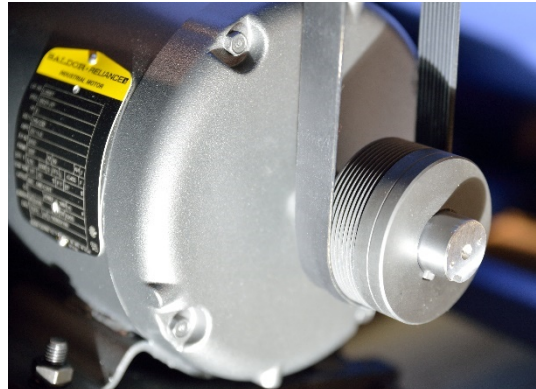

If the belt is too tight to remove, temporarily loosen the upper mounting bolts (#2). Raise the motor to loosen the belt, and remove it from the pulleys.

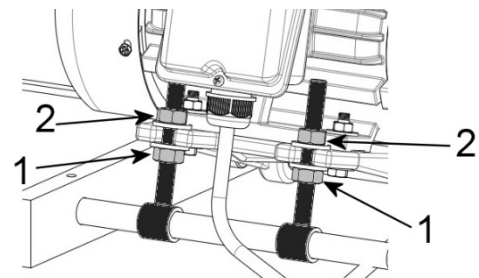

6. Install a new belt and make sure the belts sit into the grooves of pulleys.
7. Adjust belt tension and re-secure motor as needed.
8. Replace belt cover and motor access panel when maintenance completes.

Align Belt Pulleys

The belt pulleys were aligned in the factory and should not require further adjustments. Check pulley alignment if belt is slipping off the pulleys, or if the belts wears prematurely.

1. **Disconnect jointer from power source!!**
2. Remove motor access panel and the belt cover.

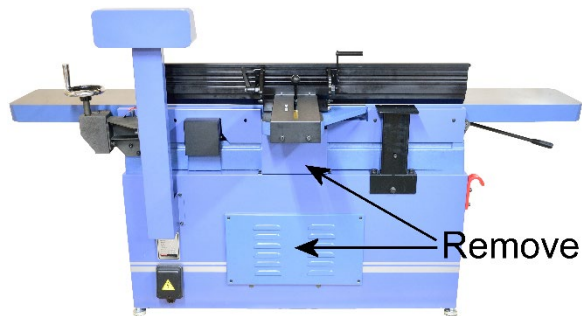

3. Use a straight edge or a tight string to check the alignment of the belt pulleys.
4. Adjustments can be made by shifting the motor pulley. Loosen the two set screws with a 5mm hex wrench, and the motor pulley can move along the motor shaft.

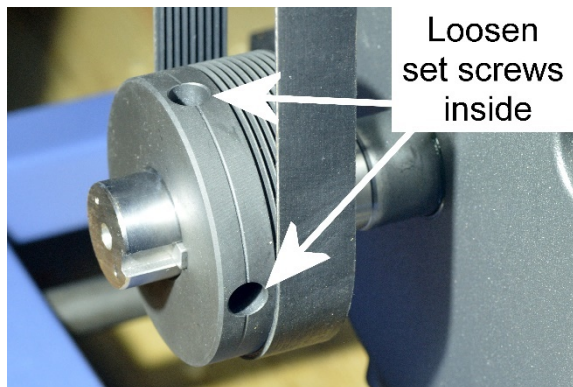

5. Realign the motor pulley with the cutterhead pulley.
6. Retighten the motor pulley locking screws, then close the belt cover and motor access panel when adjustments complete.

Troubleshooting

Problem	Possible Cause	Possible Solution
Machine does not start.	Machine is not connected to a power source.	<ol style="list-style-type: none"> 1. Make sure machine is plugged in, or power disconnect is at the ON position. 2. Check electrical panel for tripped circuit breaker or blown fuse. 3. Ensure all electrical connections have good contacts.
	Low voltage / current.	Have an electrician to check/repair the power circuit.
	Faulty switch/motor/capacitor.	Contact customer service for further assistance.
Machine trips thermal protection / circuit breaker, or blow fuses.	Machine is undersized for the operation.	Reduce depth of cut and/or feed rate.
	Workpiece moisture level is too high.	Only joint wood with moisture level below 20%.
	Machine is jammed.	Make sure cutterhead is not jammed by woodchips. Check dust chute and clear blockages.
	Too much load on a circuit.	Make sure power circuit is sized for this machine. If the same circuit is shared, ensure the circuit is sized to supply power for all items in the circuit.
	Motor/capacitor issue.	Contact customer service for further assistance.
Machine stalls during operation.	Machine is undersized for the operation.	Reduce depth of cut. Lower feed rate.
	Dull cutters	Rotate/replace cutter inserts.
	Belt slipping	Clean belt and the pulleys. Adjust belt tension.
	Motor/capacitor issue.	Contact customer service for further assistance.
Machine stopped during operation.	Thermal overload protection triggered.	Hit STOP button and wait for at least 3 minutes. When machine is cooled down, overload protection will reset automatically. Reduce depth of cut and feed rate before continue.
Outfeed table is stuck/difficult to adjust.	Outfeed table is locked.	Loosen the locking cap screw before adjusting the outfeed table.
Digital readout not functional.	Dead battery.	Replace battery.

Problem	Possible Cause	Possible Solution
Unable to lower infeed table below 1/8"	Depth stop is engaged.	Pull infeed table depth stop knob while lowering the infeed table. NOTICE: Only set depth of cut greater than 1/8" for rabbeting operations.
Outfeed table is loose and moves with the fence.	There is play in parallelogram mechanism.	Check the parallelogram mechanism and eliminate any gaps between the eccentric nut, bracket and shafts. Ensure all eccentric nuts are locked by the set screws, and each set screw is locked by blue Loctite.
Workpiece is caught on the edge of outfeed table.	Outfeed table is set too high.	Adjust outfeed table to ensure it is flush with the cutting arc of the cutterhead.
Uneven ware on cutter inserts	One section of cutterhead is used more than another.	Occasionally adjust fence's depth setting so the entire cutterhead is utilized.
Machine vibrates excessively or makes unexpected noise.	Damaged cutter inserts.	Replace cutter inserts.
	Machine stands on uneven floor.	Reposition machine on flat, level surface. Adjust leveling feet.
	V-belt worn, slipping or hitting belt cover.	Clean belt and pulleys. Adjust belt tension. Replace V-belt if it shows signs of aging.
	Improper motor mounting.	Check and adjust motor mounting.
	Loose components.	Tighten fasteners of the component.
	Worn bearings.	Contact customer service for assistance.

Problem	Possible Cause	Possible Solution
Workpiece came out twisted.	Improper feeding.	Use outfeed table as reference point for feeding. Apply even pressure and feed rate on the entire workpiece.
	Outfeed table is not in parallel with the cutterhead.	Ensure outfeed table is in parallel with cutterhead, and outfeed/infeed table are coplanar.
	More passes needed.	Significantly twisted board takes multiple passes to flatten.
Excessive snipe	Outfeed table too low.	Adjust outfeed table to ensure it is flush with the cutting arc of the cutterhead.
	Too much downward pressure when feeding the end of workpiece.	Once the workpiece reaches the outfeed table, use outfeed table as reference. Reduce feeding pressure apply to the workpiece that is still on the infeed table.
Chipping	Too much material removed in one pass.	Reduce feed rate / depth of cut.
	Planing across/end grain.	Do not use a jointer to cut across/end grain.
	Damaged cutter.	Rotate/replace cutter insert.
	Cutting against grain; or knots.	Avoid processing workpiece with knots. Cut WITH grain whenever possible. When jointing workpiece with complicated grain pattern, reduce depth of cut. Sometime moistening problematic areas can reduce chipping.
Fuzzy looking finish.	Wood moisture content too high.	Only process wood with less than 20% moisture content.
	Dull cutter.	Rotate/replace cutter insert.
	Some wood types tend to have fuzzy grain.	Adjust feed rate / depth of cut. Use sharp cutters.
Glossy looking finish.	Dull cutter.	Rotate/replace cutter insert.
	Cutting depth too shallow.	Increase depth of cut.
Long line or ridges running along the length of board.	Chipped cutter.	Rotate/replace cutter insert.
Finished stock has uneven front-to-back thickness.	Cutterhead is not flush with outfeed table.	Adjust outfeed table to ensure it is flush with the cutting arc of the cutterhead.
	Inconsistent feeding pressure applied to workpiece.	Apply even feeding pressure on workpiece. Keep feed rate consistent.
Finished stock is concave/convex in the middle.	Infeed/outfeed table are not coplanar.	Ensure outfeed table is parallel with cutterhead, and outfeed/infeed table are coplanar.

Wiring Diagram

For Stock # 4275.101.4S (230V, 1Ph)

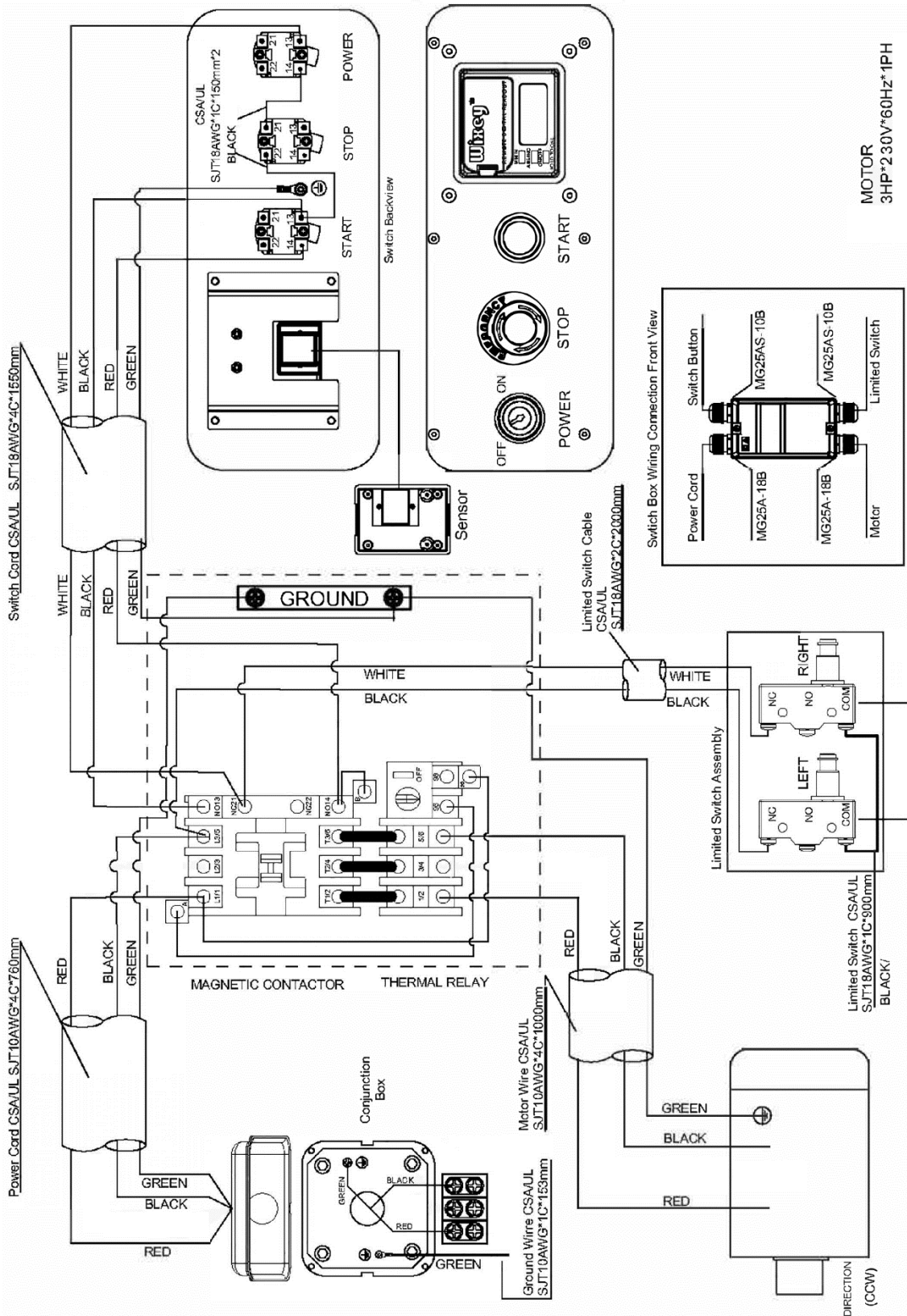

For Stock # 4275.102.4S (230/460V, 3Ph)

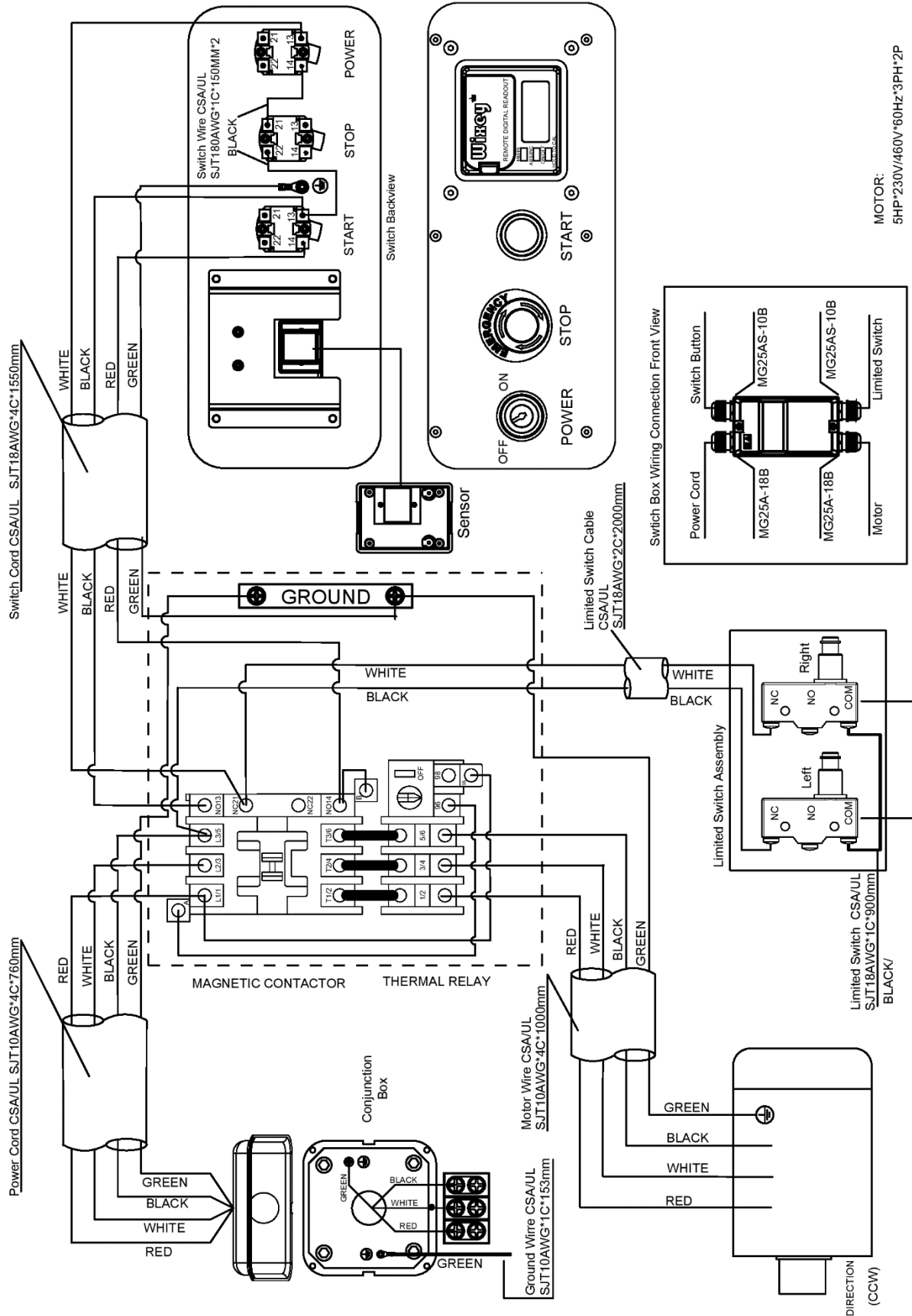

Parts List

Fence Assembly

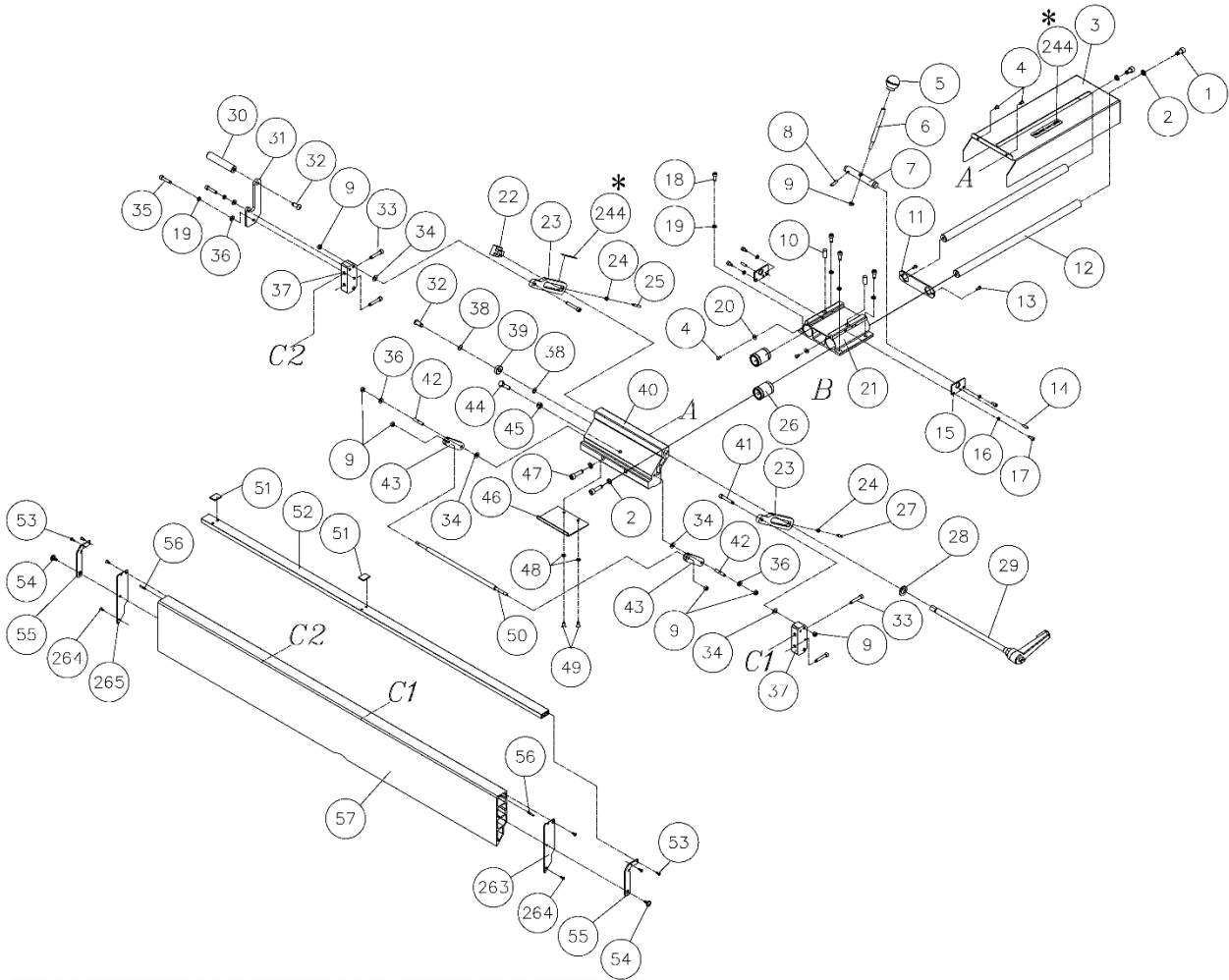

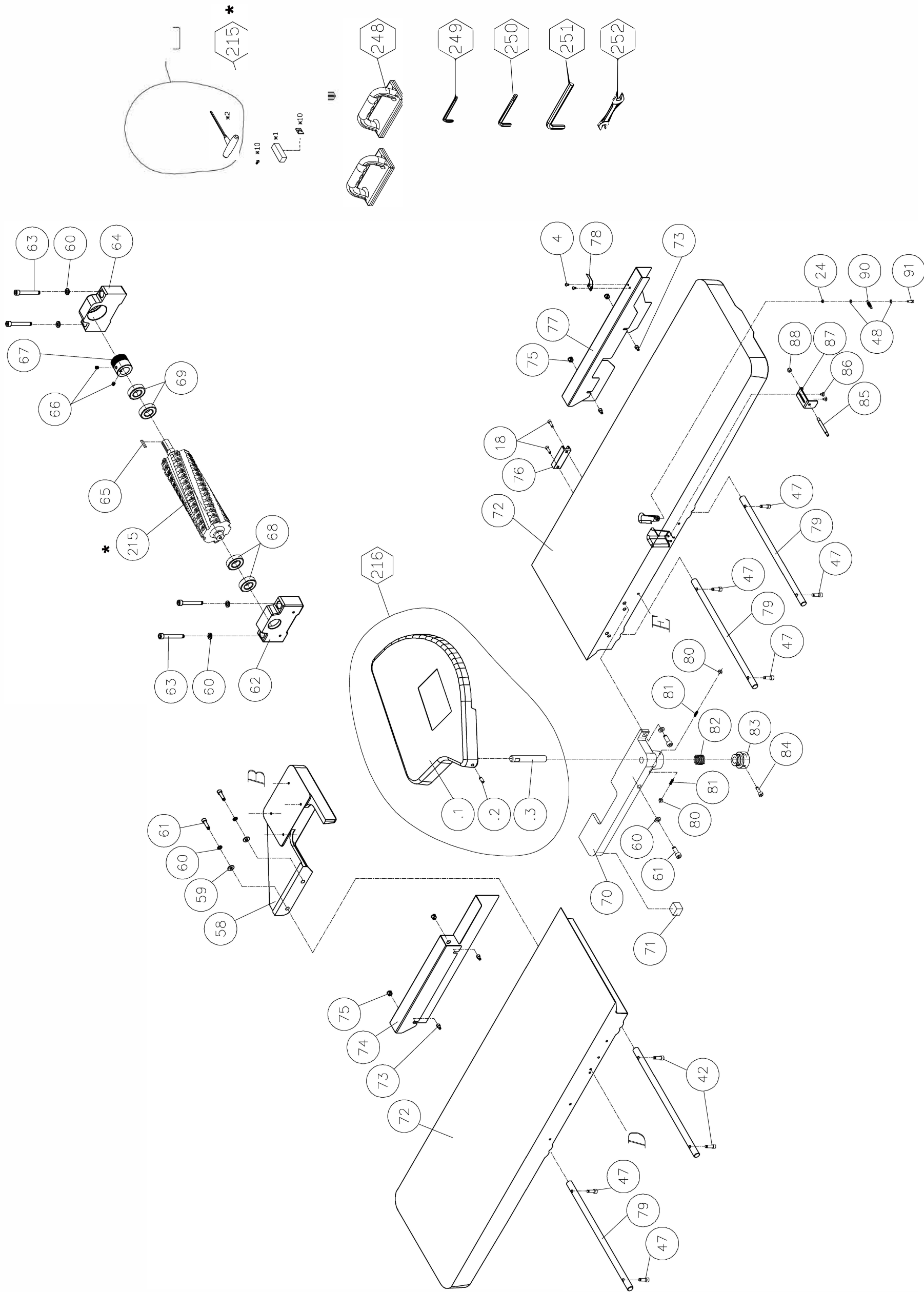

Base Assembly

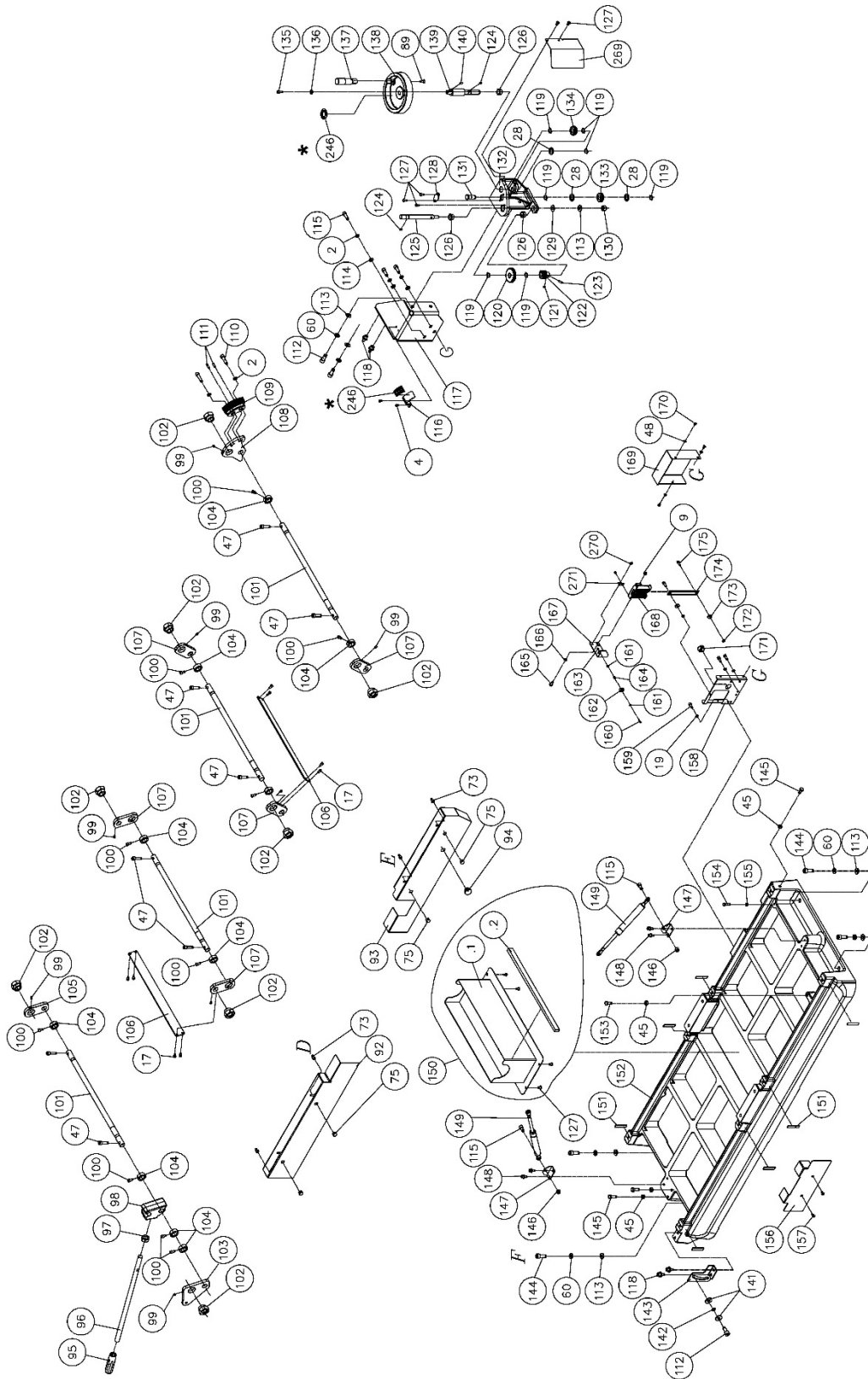

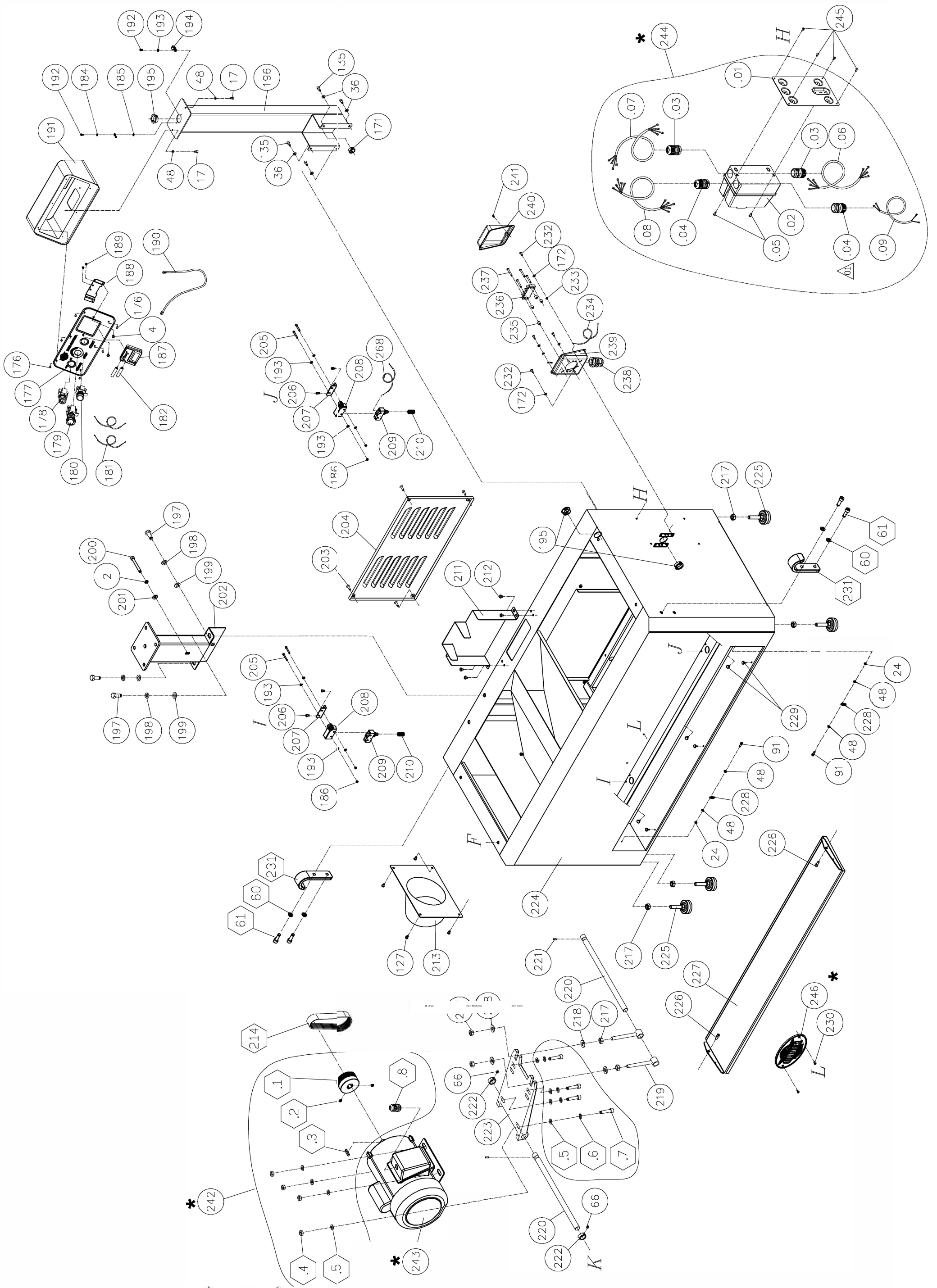

Parts List for 4275

Key	Part No.	Description	Specification	Qty
1	000104-104	Cap Screw	M8*1.25P*16	2
2	006305-100	Spring Washer	8.2*13.7	10
3	174706-008	Cover		1
4	000804-101	Flat Head Cap Screw	M5*0.8P*8	10
5	250372-615	Knob		1
6	361331-904	Rod		1
7	361330-902	Axis		1
8	011003-104	Spring Pin	5*25	1
9	008304-800	Lock Nut	M6*1.0P(10B*7H)	8
10	330066-000	Bushing		2
11	330068-000	Plate		1
12	361350-000	Rod		2
13	000101-101	Cap Screw	M4*0.7P*8	2
14	011002-110	Spring Pin	4*16	2
15	174615-904	Position Plate		2
16	006302-300	Spring Washer	5.1*9.3	4
17	000102-103	Cap Screw	M5*0.8P*10	14
18	002602-102	Cap Lock Screw	M6*1.0P*20	6
19	006303-100	Spring Washer	6.5*10.5	9
20	006001-010	Flat Washer	5.2*12*1.5t	2
21	310543-909	Fence Linear Guide Bracket		1
22	130383-903	Square Nut		1
23	381411-904	Sliding Arm		2
24	008004-100	Hex. Nut	M5*0.8P(8B*4H)	5
25	000202-105	Set Screw	M5*0.8P*30	1
26	034403-001	Linear Bearing	LM20UU	2
27	000202-106	Set Screw	M5*0.8P*20	1
28	006001-125	Flat Washer	15.5*25*2.5t	3
29	230405-000	Adjusting Handle		1
30	361333-904	Shaft		1
31	174620-904	Fence Adjust Plate		1
32	000802-102	Flat Head Cap Screw	M8*1.25P*20	2
33	000103-110	Cap Screw	M6*1.0P*35	4
34	006004-205	Flat Washer	6.8*14*0.3t	4
35	000103-108	Cap Screw	M6*1.0P*25	2

Key	Part No.	Description	Specification	Qty
36	006011-023	Flat Washer	6.3*13*2.0t	8
37	300119-911	Shaft Block		2
38	006001-044	Flat Washer	8.5*16*0.8t	2
39	030101-001	Ball Bearing	608-ZZ	1
40	310542-911	Fence Position Bracket		1
41	000103-811	Cap Screw	M6*1.0P*40	2
42	361359-902	Stud		2
43	174622-904	Link		2
44	000003-108	Hex. Screw	M8*1.25P*40	1
45	008006-100	Hex. Nut	M8*1.25P(13B*6.5H)	5
46	174616-904	Plate		1
47	000104-110	Cap Screw	M8*1.25P*30	18
48	006001-009	Flat Washer	5.2*10*1.0t	13
49	000402-104	Pan Phillips Screw	M5*0.8P*12	2
50	361367-902	Link Bolt		1
51	250602-621	Plate		2
52	310522-911	Auxiliary Fence		1
53	001102-504	Self-Tapping Screw	M4*1.59P*12	4
54	290104-902	Shoulder Screw		2
55	174614-904	Supporting Plate		2
56	360249-905	Pin		2
57	310518-911	Fence		1
58	051396-000	Fence Base		1
59	006001-068	Flat Washer	10*20*2.0t	2
60	006307-100	Spring Washer	10.2*18.5	17
61	000105-103	Cap Screw	M10*1.5P*30	7
62	051436-902	Bearing Housing (Front)		1
63	000105-109	Cap Screw	M10*1.5P*75	4
64	051435-902	Bearing Housing (Rear)		1
65	012006-001	Key	8*8*40	1
66	001903-105	Set Lock Screw	M8*1.25P*8	4
67	381414-902	Cutterhead Pulley		1
68	030208-002	Ball Bearing	6204-2NSE	2
69	030210-002	Ball Bearing	6206-2NSE	2
70	051183-000	Rabbeting Table		1
71	200105-615	Sponge	30*30*22(L*W*H)	1
72	051434-000	Table (infeed or outfeed)		2

Key	Part No.	Description	Specification	Qty
73	000103-102	Cap Screw	M6*1.0P*10	8
74	174645-000	Rear Cover (Left)		1
75	042505-000	Plug	HP-13	8
76	300118-909	Position Bracket		1
77	174646-000	Rear Cover (Right)		1
78	174649-156	Scale Pointer		1
79	361348-902	Table Shaft		4
80	009004-100	Hex. Nut	1/4"-20NC(11B*5.5H)	2
81	230275-000	Set Screw	1/4"-20NC*3/4"	2
82	280165-000	Torsion Spring		1
83	380825-901	Knob		1
84	000104-708	Cap Screw	M8*1.25P*25	1
85	361336-902	Round Standoff		1
86	290028-901	Shoulder Screw		2
87	174655-902	Position Plate		1
88	009103-100	Lock Nut	1/4"-20NC(11B*8H)	1
89	000702-104	Socket Flat Head Hex Screw	Only used SN 192994 and beyond	1
90	280082-000	Torsion Spring		1
91	000102-116	Cap Screw	M5*0.8P*15	3
92	174644-000	Front Cover (Left)		1
93	174643-000	Front Cover (Right)		1
94	230156-615	Knob		1
95	250496-615	Handle		1
96	361300-902	Rod		1
97	008011-100	Hex. Nut	M16*2.0P(24B*13H)	1
98	051401-902	Elevation Bracket		1
99	001902-102	Set Lock Screw	M6*1.0P*8	8
100	002602-101	Cap Lock Screw	M6*1.0P*12	10
101	361349-902	Shaft		4
102	381392-902	Eccentric Bushing		8
103	174513-902	Shaft Plate		1
104	381393-902	Bushing		10
105	174512-902	Shaft Plate		1
106	174705-000	Plate		2
107	174650-902	Shaft Plate		5
108	174515-902	Shaft Plate		1
109	070070-902	Toothed Bracket		1

Key	Part No.	Description	Specification	Qty
110	000104-111	Cap Screw	M8*1.25P*35	2
111	011103-103	Pin	5.0*20	2
112	000105-102	Cap Screw	M10*1.5P*25	3
113	006001-075	Flat Washer	10.3*22*2.0t	7
114	006001-038	Flat Washer	8*16*1.6t	3
115	000104-106	Cap Screw	M8*1.25P*20	5
116	174656-904	Scale Seat		1
117	174516-902	Position Bracket		1
118	001501-101	Cap w/Spring Washer/Flat Washer	M8*1.25P*20/8.2*15.4/8.5*19*2t	4
119	010006-000	S Ring	STW-15	7
120	320398-000	Gear	50T	1
121	000203-101	Set Screw	M6*1.0P*6	1
122	361301-902	Worm Gear		1
123	011003-114	Spring Pin	5*20	1
124	012003-001	Key	5*5*8	2
125	361302-902	Position Shaft		1
126	330067-000	Bushing		3
127	000801-101	Flat Head Cap Screw	M6*1.0P*10	11
128	174518-902	Plate		1
129	006004-070	Flat Washer	10*22*0.8t	1
130	008308-100	Lock Nut	M10*1.5P(17B*12H)	1
131	381395-902	Position Bolt		1
132	051407-902	Bracket		1
133	320399-000	Gear	30T	1
134	320397-000	Gear	30T	1
135	000103-103	Cap Screw	M6*1.0P*12	5
136	006001-025	Flat Washer	6.4*16*1.0t	1
137	230114-906	Handle Chrome	SN 192988 to 192993	1
137	230284-000	Black Folding Handle	SN 192994 and beyond.	1
138	240061-008	Hand Wheel Chrome	SN 192988 to 192993	1
138	240092-008	Hand Wheel Black	SN 192994 and beyond.	1
139	361304-902	Handwheel Shaft	SN 192988 to 192993	1
139	361395-902	Handwheel Shaft	SN 192994 and beyond.	1
140	012002-004	Key	SN 192988 to 192993	1
140	012002-006	Key	SN 192994 and beyond.	1
141	006001-071	Flat Washer	10*25*3.0t	2
142	006703-100	Wavy Washer	WW-10	1

Key	Part No.	Description	Specification	Qty
143	174514-902	Outfeed Table Lock Plate		1
144	000105-105	Cap Screw	M10*1.5P*40	4
145	000003-105	Hex. Screw	M8*1.25P*25	3
146	008306-100	Lock Nut	M8*1.25P(13B*9H)	2
147	174653-902	Bracket		2
148	001502-102	Cap w/Spring Washer/Flat Washer	M6*1.0P*16/6.5*10.5/6.3*13*1.0t	4
149	660292-000	Hydraulic Cylinder		2
150	924706-000	Dust Cover Assembly		1
150.1	174704-008	Dust Cover		1
150.2	200107-615	Sponge		1
151	200024-615	Vibration Absorbing Pad		7
152	051433-000	Base		1
153	000003-106	Hex. Screw	M8*1.25P*30	1
154	000002-107	Hex. Screw	M6*1.0P*40	1
155	008005-100	Hex. Nut	M6*1.0P(10B*5H)	1
156	174647-000	Cutterhead Front Cover		1
157	000801-104	Flat Head Cap Screw	M6*1.0P*20	2
158	174612-008	Digital Readout Position Plate		1
159	000103-106	Cap Screw	M6*1.0P*16	3
160	000301-204	Pan Phillips Screw	M3*0.5P*15	1
161	006002-139	Flat Washer	3*8*1.0t	2
162	030127-001	Ball Bearing	606-ZZ	1
163	008315-200	Lock Nut	M3*0.5P(5.5B*4H)	1
164	360906-902	Bushing		1
165	000002-101	Hex. Screw	M6*1.0P*12	1
166	006001-155	Flat Washer	6*12*1t	1
167	174652-000	Bracket		1
168	491128-000	Sensor	WR5501	1
169	174611-008	Cover		1
170	000102-101	Cap Screw	M5*0.8P*6	3
171	021801-000	Snap Bushing	NB-1722	2
172	006001-131	Flat Washer	5.3*10*2.0t	6
173	006001-181	Flat Washer	5*16*3.0t	2
174	950785-000	Magnetic Strip Assembly	Depth:3/4"	1
175	002603-702	Cap Lock Screw	M5*0.8P*16	2
176	000805-101	Flat Head Cap Screw	M4*0.7P*6	6
177	574956-000	Switch Panel		1

Key	Part No.	Description	Specification	Qty
178	490019-000	Key Switch		1
179	490039-000	Stop Switch		1
180	490040-000	Start Switch		1
181	471037-083	CSA Cable	SJT18AWG*1C*150mm	2
182	Local Purchase	Battery	AAA	2
184	006501-100	Outer Toothed Washer	4.3*8.5(BW-4)	1
185	006002-200	Flat Washer	4.3*8*0.8t	1
186	008002-200	Hex. Nut	M4*0.7P(7B*3.2H)	4
187	491130-000	Digital Readout	WR5502 (Wixey)	1
188	174750-000	Position Bracket		1
189	001101-203	Self-Tapping Screw	M3*1.06P*8	2
190	730139-001	Transmission Cable	Cat 5E* RJ-45-CT-A *2M	1
191	174770-000	Switch Box		1
192	000302-102	Pan Phillips Screw	M4*0.7P*8	2
193	006001-001	Flat Washer	4.3*10*1.0t	9
194	021103-100	Zip Tie	ACC-3-B	1
195	021802-000	Snap Bushing	NB-2430	3
196	924571-000	Switch Pedestal Assembly		1
197	000005-111	Hex. Screw	M12*1.75P*30	3
198	006308-100	Spring Washer	12.2*21.6	3
199	006001-136	Flat Washer	12.2*23*2.0t	3
200	000104-117	Cap Screw	M8*1.25P*70	1
201	006001-054	Flat Washer	8.5*20*2.0t	1
202	381391-308	Bracket		1
203	000403-104	Pan Phillips Screw	M6*1.0P*20	4
204	170479-000	Rear Access Panel		1
205	000101-110	Cap Screw	M4*0.7*30	4
206	000102-102	Cap Screw	M5*0.8P*8	4
207	174651-902	Bracket		2
208	490229-615	Switch Cover	KSSCB-2	2
209	491101-000	Micro Switch	MJ2-1307	2
210	280274-000	Spring		2
211	174642-000	Belt Guard		1
212	001603-102	Phillip Head Screw w/Flat Washer	M6*1.0P*10/6*13.2*1.0t	4
213	174641-008	Dust Port		1
214	014343-000	V-Belt	490J-9	1
215	JP02-12	Cutterhead Assembly		1

Key	Part No.	Description	Specification	Qty
	040710-000	Torx Screwdriver	T-25	2
	038201-101	Torx Screw	#10-32NF*1/2"	76
	P-15mm 4S	Inserts Sold in Packs of 10	15*15*2.5t	76
<i>SN 192988 to 192996 feature a BYRD Cutterhead Use item #A-BYRD for replacement inserts (Qty 80).</i>				
216	924705-000	Cutterhead Guard Assembly		1
216.1	300111-000	Cutterhead Guard		1
216.2	000204-103	Set Screw	M8*1.25P*12	1
216.3	360869-901	Guard Pivot Shaft		1
217	008009-100	Hex. Nut	M12*1.75P(19B*10H)	8
218	006001-091	Flat Washer	13*28*3.0t	4
219	380249-901	Adjusting Shaft Assembly		2
220	361303-902	Supporting Shaft		2
221	001902-105	Set Lock Screw	M6*1.0P*12	2
222	190074-901	Spacer		2
223	050321-008	Motor Mounting Plate		1
224	174703-000	Stand		1
225	230403-000	Foot		4
226	000103-120	Cap Screw	M6*1.0P*15	2
227	174762-156	Emergency Stop Foot Switch		1
228	280050-000	Spring		2
229	340007-615	Rubber Packing		6
230	000401-104	Pan Phillips Screw	M4*0.7P*10	2
231	170638-156	Lifting Hook		2
232	000303-104	Pan Phillips Screw	M5*0.8P*12	4
233	006502-300	Outer Toothed Washer	5.3*10(BW-5)	2
234	471008-001	CSA Cable	10AWG*1C*153mm	1
235	250573-615	Bushing		4
236	490336-000	Terminal Socket	HD-30-A3(600V/40A)	1
237	000303-109	Pan Phillips Screw	M5*0.8P*35	4
238	021314-000	Strain Relief	MG25A-18B (w/nut)	1
239	491116-008	Junction Box Lower Cover		1
240	490124-008	Junction Box Upper Cover		1
241	003303-102	Pan Phillips Screw	3/16"-24NC*1/4"	1
242.1	381412-902	Motor Pulley		1
242.2	001903-105	Set Lock Screw	M8*1.25P*8	2
242.3	013003-001	Key	1/4"*1/4"*1-1/2"	1
242.4	008007-100	Hex. Nut	M10*1.5P(17B*8H)	4

Key	Part No.	Description	Specification	Qty
242.5	006001-068	Flat Washer	10*20*2.0t	8
242.6	006307-100	Spring Washer	10.2*18.5	4
242.7	000105-105	Cap Screw	M10*1.5P*40	4
242.8	021314-000	Strain Relief	MG25A-18B (w/nut)	1
243	L3608T	Baldor Motor	5HP 1Ph 230V	1
	EM3616T	Baldor Motor	7.5HP 3Ph 230/460V	1
244	938014-000	Magnetic Switch Assembly		1
244.01	170977-901	Switch Plate		1
244.02	823017-058	Magnetic Switch		1
NS	490270-000	220V Magnetic Contactor	MA-18	1
NS	490296-000	220V Overload	12 - 18A	1
244.03	021313-000	Strain Relief	MG25A-18B (no nut)	2
244.04	021377-000	Strain Relief	MG25AS-10B (no nut)	2
244.05	000303-104	Pan Phillips Screw	M5*0.8P*12	2
244.06	474005-015	CSA Cable	SJT 10AWG*4C*1000mm	1
244.07	474005-016	CSA Cable	SJT 10AWG*4C*760mm	1
244.08	474001-013	CSA Cable	SJT 18AWG*4C*1550mm	1
244.09	472001-050	CSA Cable	SJT 18AWG*2C*2000mm	1
<i>Note: 440V 3Phase operation requires special components, contact Oliver Machinery.</i>				
NS	491192-000	440V Magnetic Contactor		1
NS	490717-000	440V Overload	8 - 10 - 12A	1
Key	Part No.	Description	Specification	Qty
245	000804-103	Flat Head Cap Screw	M5*0.8P*10	4
246		Label	Advise content/location to order	
248	250035-629	Push Blocks		2
249	Local Purchase	Hex. Wrench	5mm	1
250	Local Purchase	Hex. Wrench	6mm	1
251	Local Purchase	Hex. Wrench	8mm	1
252	Local Purchase	Open End Wrench	12mm/14mm	1
265	174618-904	Fence Cap (Right)		1
266	029001-701	Socket Flat Head Self-Tapping Screw	M4*1.41*10	4
267	174619-904	Fence Cap (Left)		1
268	471037-095	CSA Cable	SJT 18AWG*1C*900mm	1

Maintenance Record

Date	Task	Operator

Notes

Warranty and Service

Oliver Machinery makes every effort to assure that its equipment meets the highest possible standards of quality and durability. All products sold by Oliver Machinery are warranted to the original customer to be free from defects for a period of two (2) years on all parts excluding electronics and motors which are warranted for one (1) year from the date of shipment. Oliver Machinery's obligation under this warranty shall be exclusively limited to repairing or replacing products or parts or components, at its sole option, determined by Oliver Machinery to be defective. Oliver Machinery shall not be required to provide other form of indemnity or compensation including but not limited to compensatory damages.

This warranty does not apply to defects due to direct or indirect misuse, abuse, negligence, accidents, unauthorized repairs, alternation outside our facilities, lack of maintenance, acts of nature, or items that would normally be consumed or require replacement due to normal wear and tear.

OTHER TERMS

To obtain and exercise the warranty right, please call 800-559-5065 or fill out warranty request form online at www.olivermachinery.net.

Warranty parts are shipped via Parcel or Ground. Additional charge will occur and charge to customers if express shipping is required.

DISCLAIMER

Under no circumstances shall Oliver Machinery be liable for death, personal or property injury or damages arising from the use of its products.

Oliver Machinery reserves the right to make changes without prior notice to its products to improve function or performance or design.

FOR MORE INFORMATION

If you need assistance or have questions beyond what is covered in the scope of this warranty information, please call 800-559-5065 or email us at info@olivermachinery.net.

Appendix

US Standard – Metric Conversion Chart

Fractions	Decimal In.	Millimeters
1/64	.0156	.396
1/32	.0312	.793
3/64	.0469	1.190
1/16	.0625	1.587
5/64	.0781	1.984
3/32	.0937	2.381
7/64	.1094	2.778
1/8	.125	3.175
9/64	.1406	3.571
5/32	.1562	3.968
11/64	.1719	4.365
3/16	.1875	4.762
13/64	.2031	5.159
7/32	.2187	5.556
15/64	.2344	5.953
1/4	.25	6.350
17/64	.2656	6.746
9/32	.2812	7.143
19/64	.2969	7.540
5/16	.3125	7.937
21/64	.3281	8.334
11/32	.3437	8.731
23/64	.3594	9.128
3/8	.375	9.525
25/64	.3906	9.921
13/32	.4062	10.318
27/64	.4219	10.715
7/16	.4375	11.112
29/64	.4531	11.509
15/32	.4687	11.906
31/64	.4844	12.303
1/2	.5	12.700

Fractions	Decimals In.	Millimeters
33/64	.5156	13.096
17/32	.5312	13.493
35/64	.5469	13.890
9/16	.5625	14.287
37/64	.5781	14.684
19/32	.5937	15.081
39/64	.6094	15.478
5/8	.625	15.875
41/64	.6406	16.271
21/32	.6562	16.668
43/64	.6719	17.065
11/16	.6875	17.462
45/64	.7031	17.859
23/32	.7187	18.256
47/64	.7344	18.653
3/4	.75	19.050
49/64	.7656	19.446
25/32	.7812	19.843
51/64	.7969	20.240
13/16	.8125	20.637
53/64	.8281	21.034
27/32	.8437	21.431
55/64	.8594	21.828
7/8	.875	22.225
57/64	.8906	22.621
29/32	.9062	23.018
59/64	.9219	23.415
15/16	.9375	23.812
61/64	.9531	24.209
31/32	.9687	24.606
63/64	.9844	25.003
1.0	1.	25.400



Oliver Machinery is always adding new Industrial Woodworking products to the line.

For complete, up-to-date product information, visit us online at:

WWW.OLIVERMACHINERY.NET

or call toll free 1-800-559-5065

**** SAVE THIS MANUAL FOR FUTURE REFERENCES. ****