



Proudly Manufactured



In the USA
American Castings
American Motors

Operations & Maintenance Manual and Parts Bulletin

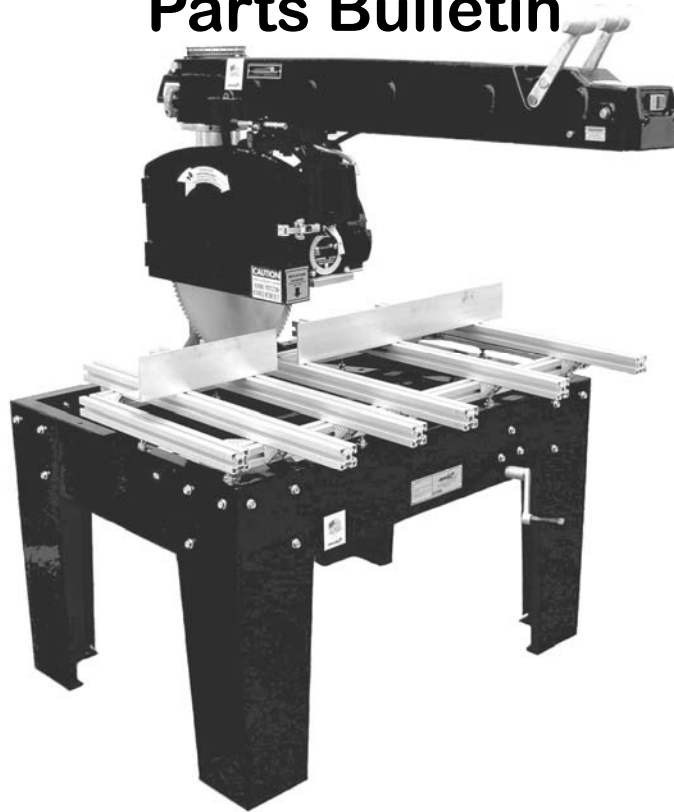

WARNING: FOR YOUR SAFETY READ AND UNDERSTAND THIS MANUAL PRIOR TO USING THE SAW. REVIEW ALL SAFETY RULES AND OPERATING INSTRUCTIONS FREQUENTLY.

This manual is provided for your convenience in the use and care of your saw. These instructions include operation, precautions, preventative maintenance and other pertinent data to assist you in assuring long life and dependable service from your saw.

**16" Metal Cutting Radial Arm Saw
TYPE 7
MODELS 3579-16M, 3579-16L**

**20" Metal Cutting Radial Arm Saw
TYPE 7
MODELS 3579-20M, 3579-20L
For s/n 071010997 forward**

INDEX

General Safety Precautions/Specifications . . .	3-4	Parts Diagram and Listings	17-25
Unpacking and Assembly.	5-6	Setting Thermal Overload Relay/Changing Voltage	26-27
Operating Cautions/Alternative Setup	7	Troubleshooting.	28-30
Operating Instructions.	8-11	Accessories/Preventive Maintenance.	31
Adjustments and alignments.	12-16	Warranty Information/Factory Service	32

General Rules for Safe Operation of Power Tools

1. KNOW YOUR POWER TOOL— Read the owner’s manual carefully. Learn the applications and limitations as well as the specific potential hazards of the tool.
2. GROUND ALL TOOLS.
3. KEEP GUARDS IN PLACE. Keep guards in working order.
4. KEEP WORK AREA CLEAN. Cluttered areas and benches invite accidents.
5. AVOID DANGEROUS ENVIRONMENTS. Don’t use power tools in damp or wet locations. Keep work area well lit.
6. KEEP CHILDREN AWAY. All visitors should keep a safe distance from the work area.
7. DON’T FORCE TOOL. The tool will do a better job if used at its designed rate.
8. WEAR PROPER APPAREL. Loose clothing, gloves or jewelry may get caught in moving parts. Rubber footwear is recommended when working outdoors.
9. USE PROTECTIVE GLASSES. If operation is dusty also where a face or dust mask.
10. DON’T OVERREACH. Keep proper balance and footing at all times.
11. MAINTAIN TOOLS WITH CARE. Tools kept sharp and clean provide the best and safest performance. Follow instructions for lubricating and changing accessories.
12. DISCONNECT TOOLS FROM POWER SOURCE. When not in use, before servicing, when changing accessories, such as blades or cutters, the tool should be disconnected and locked out.
13. REMOVE ADJUSTING KEYS AND WRENCHES. Make it a habit to ensure keys and adjusting wrenches are removed prior to starting tool.
14. USE RECOMMENDED ACCESSORIES. Consult your distributor or the Original Saw Company for recommended accessories. Using improper accessories may cause hazards.
15. SECURE YOUR WORK. Use clamps or vise to hold work when practical.
16. NEVER LEAVE TOOL RUNNING WHILE UNATTENDED.
17. ONE OPERATOR ONLY. The person who pulls the saw should position the work.
18. DO NOT REMOVE SMALL SCRAPS FROM THE TABLE WITH YOUR FINGERS.

!!! CAUTION !!!

FOR ILLUSTRATION PURPOSES ONLY, THE LOWER GUARD HAS BEEN REMOVED FOR THE PHOTOS USED IN THIS MANUAL. IN ACTUAL USE BOTH UPPER AND LOWER GUARDS MUST REMAIN IN PLACE FOR SAFE CUTTING OPERATION.

This manual is not totally comprehensive. It does not and cannot cover every possible safety and operational factor which may arise during the life of the machine.

16" & 20" RADIAL ARM SAWS

MODEL	MOTOR SIZE	VOLTAGE	GUARD SIZE	ARM LENGTH
3579-16M Type 7	7.5 hp 3 phase	208/230/460 V 50/60 Hz	16"	44"
3579-16L Type 7	7.5 hp 3 phase	208/230/460 V 50/60 Hz	16"	52"
3579-20M Type 7	7.5 hp 3 phase	208/230/460 V 50/60 Hz	20"	44"
3579-20L Type 7	7.5 hp 3 phase	208/230/460 V 50/60 Hz	20"	52"
Machines wired for 380 and 575 volt operation also available				
Model numbers and serial numbers are found on a tag located on the front of the frame.				

Specifications

MODEL:	3579-16M	3579-16L	3579-20M	3579-20L	3579-22M	3579-22L
Arm	Medium	Long	Medium	Long	Medium	Long
Blade Size	16" / 400mm	16" / 400mm	20" / 500mm	20" / 500mm	22" / 550mm	22" / 550mm
MOTOR: ALL MOTORS TOTALLY ENCLOSED FAN COOLED						
HP	7.5*	7.5*	7.5*	7.5*	7.5*	7.5*
Phase	3	3	3	3	3	3
Hertz	50/60	50/60	50/60	50/60	50/60	50/60
Volts *	230/460 **	230/460 **	230/460 **	230/460 **	230/460 **	230/460 **
Amp (FLA)						
Watts						
Brake	automatic	automatic	automatic	automatic	automatic	automatic
Arbor	1" dia x 1 3/8"	1" dia x 1 3/8"	1" dia x 1 3/8"	1" dia x 1 3/8"	1" dia x 1 3/8"	1" dia x 1 3/8"
CAPACITIES: inches/metric						
Max Cross Cut 1" Stock	24" / 609mm	32" / 812mm				
Max Miter 45° 1" Stock	16" / 406mm	21 5/8" / 549mm				
Max Depth of Cut	4 3/8" / 111 mm	4 3/8" / 111 mm	7" / 175 mm	7" / 175 mm	8" / 200 mm	8" / 200 mm
Max Depth of Cut 45° Bevel	2" / 50mm	2" / 50mm	3 3/8" / 85 mm	3 3/8" / 85 mm	4" / 101 mm	4" / 101 mm

FLOOR MOUNTING DIMENSIONS

Your saw may be mounted to the floor. Use the diagram at right to assist you in placing the saw and fastening it to the floor.

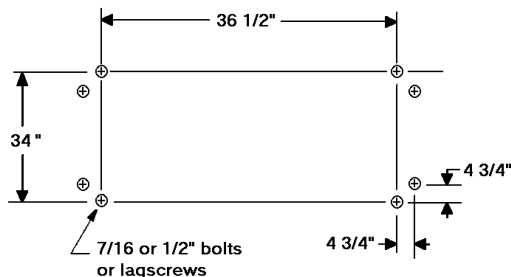

Unpacking

The box included in your shipment contains the legs, hardware and wrenches. Please use the following procedure to remove the box: Remove the elevating handle from the hardware bag fastened to the carton top. Install handle on shaft located at the lower right side of saw frame. Release the column clamp, elevate the arm and remove carton.

Attaching the Table Legs

The machine can be lifted with a fork lift under the steel saw frame. A sling or chain hoist may be used under the arm ONLY if placed at the rear of the arm near the column.

Attach the legs using the 3/8" hexhead cap screws, lock washers and nuts provided in the hardware bag.

Tighten cap screws securely after the machine has been lowered onto its legs. When the saw has been placed in its permanent location shim the legs where necessary to provide a solid foundation. This is important to maintaining an accurate cut. In order to prevent the forward movement of the carriage when the operator releases his grip, it is recommended the front legs be shimmed.

Important

Loosen the 2 cable clamps (1 inside of arm, 1 at right rear of arm) and adjust the cables so rollerhead is free to travel the total length of the arm with the motor pivoted in the roller head so the blade is on the right hand side. Also, check to ensure there is enough slack in the cables between the rear of the arm and the starter enclosure so the arm can be swung to the right a full 90° while the arm is elevated to its highest position.

Electrical Hookup Recommended Copper Wire Sizes (A.W.G.)

To obtain maximum efficiency from your saw motor, the feeder wire from the power source to the machine should comply with the table below.

Motor Horsepower	1 Phase	3 Phase		
	200-240 V	200-240 V	440-480 V	550-600 V
5	6	6	—	—
7.5	—	4	6	8

NOTE: This table is based on 60-100' distances from power supply. Less than 60' may use one even size smaller (high number = smaller size); 100-160' use one even size larger, over 160' use two even sizes larger.

Connecting Electrical Current

The motor is properly connected to the magnetic switch at the factory for operation on the electrical voltage specified on the tag attached to the starter enclosure. Make sure incoming voltage from your power supply conforms to the voltage specified on the tag.

Remove the magnetic switch cover and insert power supply cable through the dust proof fitting. Connect wires to L1, L2 and L3 for 3 phase; L1 and L2 for single phase. Attach the ground wire to the ground lug inside the switch enclosure. Wiring must conform to the National Electrical Code and any applicable local codes.

Check Arbor Rotation (3 Phase Only)

Check arbor rotation with arbor nut and arbor collars removed. Open line disconnect to the saw to remove arbor nut and collars, close the line disconnect and start saw. The rotation of the arbor must be clockwise as indicated on the arrow on the nameplate. If the rotation is counterclockwise, the incoming wires are not properly connected to the switch box. To change the direction reverse any two of the wire leading to the switch box from the power supply.

Changing Voltage (Dual Voltage Motors Only)

Dual voltage motors can be operated on either of the two voltages indicated on the motor nameplate. On the tag attached to the guard stud, you will find the voltage that was set at the factory. To change the voltage:

1. Change the motor lead connections as shown on the diagram on the inside cover of the motor conduit box. This is also found on pages 25-26 in this manual. Be sure to disconnect and lockout the power supply before attempting voltage change.
2. Reconnect the transformer in the magnetic starter as shown in the diagram on the inside of the starter box cover. This is also found on pages 26 of this manual.
3. Replace the thermal overload protectors with those rated at the desired voltage. See page 25 of this manual.
4. Contact your dealer for correct thermal overload protectors.

Overload Protection

Your saw is equipped with automatic reset thermal overload protection. To restart after thermals have tripped, wait until the motor cools, then press the saw start button. If overloads continue to trip the machine is being overloaded. Do not continue to operate under these conditions. Find the trouble and correct it—see the electrical trouble shooting section of this manual. The power supply branch circuit should be fused as follows using Time Delay fuses:

Motor Horsepower	1 Phase	3 Phase		
	200-240 V	200-240 V	440-480 V	550-600 V
5	60	30	—	—
7.5	—	50	25	20

Electrical Precautions

1. Be sure machine is properly grounded.
2. Do not attempt to operate saw on any voltage other than the one designated.
3. Use correct size time delay fuses to protect incoming current.
4. If it takes more than 3 seconds to reach maximum speed with a standard blade, turn the saw off. (See trouble shooting on page 27 of this manual).
5. Do not cause the motor to repeatedly approach a stall.
6. Do not attempt to start the saw for at least 15 minutes after thermal overload has tripped.
7. Disconnect and lockout the saw from the power source before opening a starter box, conduit box or whenever removing a guard.

Mounting the Blade (Caution! Disconnect power source before mounting blade)

1. Place the hex box wrench over the arbor nut and place the long allen wrench in the arbor shaft end hole. Place a wood striking block under the allen wrench to avoid marring the tabletop. Push down on the hex wrench to loosen nut (left hand threaded). (See figure 2)
2. Remove the nut and first arbor collar. Wipe the arbor collar faces and mounting area on the blade. Slide the blade on the shaft with the directional arrow away from the motor and pointing clockwise.
3. Place the arbor collar, recessed sides against the blade, arbor nut and tighten securely. (See figure 1)



FIGURE 1



FIGURE 2

General Safety Precautions

1. Be sure the blade rotates clockwise when facing the saw from the left side. Blade must rotate to the front of the saw.
2. Be sure all clamp handles are tight before turning motor on.
3. Keep the blade sharp and properly set.
4. Hold material firmly against the guide strip when cutting.
5. Be sure the blade and arbor collars are clean and the recessed side of the collars are against blade.
6. Never oil or grease arm trackways or motor.
7. Do not start machine without proper tool guard.
8. Do not remove the anti-kickback device from the blade guard. Adjust it to just clear the work.
9. Keep motor air slots clean.
10. Return roller head to full rear after each operation.

General Cautions When Using the Lower Blade Guard:

1. The lower blade guard will provide protection from contact with the side of the blade. It is not designed to prevent contact with the front or rear of the blade. When the lower guard contacts the fence or material being cut it will rise up exposing the blade. Be careful to keep your hands out of the line of the cut.
2. Lower blade guards may become caught in prior kerfs in the fence or table. Replace guide fence frequently. If guard becomes caught stop saw before attempting to remove.
3. Short cut-off pieces of wood may become caught between the lower guard and the blade. If this happens shut off the saw and wait until blade stops to remove the piece.
4. The lower blade guard's effectiveness is limited in bevel operations. It may have to be raised out of the way when setting the bevel angle. **Be sure the power is off/locked out and blade is completely stopped before making any adjustment.**
5. Catching the lower guard in saw kerfs when changing the saw setup can be avoided by elevating the saw until the bottom of the guard clears the fence.
6. When ripping narrow strips the lower guard may have to be raised to rest on top of the guide fence. Be sure to use a pusher stick to feed the work.
7. Do not use the lower guard with any accessory other than the correct size blade.

Using the Adjustable Rollerhead Stop

The rollerhead stop should be used whenever rollerhead travel needs to be limited for example when repetitive cross cuts are being made. Use of the rollerhead stop will also prevent the blade from throwing small cut off pieces on the return stroke.

Do not adjust the rollerhead stop unless the power is off and locked out and the blade stopped. The rollerhead stop must be used on the right side of the arm. Proper adjustment of the rollerhead stop is completed as follows:

1. Pull the rollerhead forward far enough for the blade to sever the material and travel 1/4" past the material.
2. Lock the rollerhead to the arm with the riplock and place the rollerhead stop so it is touching the rollerhead and tighten the knob.
3. Loosen the riplock and return the rollerhead behind the fence.



Operating Instructions

!!! CAUTION !!!

FOR ILLUSTRATION PURPOSES ONLY, THE LOWER GUARD HAS BEEN REMOVED FOR THE PHOTOS USED IN THIS MANUAL. IN ACTUAL USE BOTH UPPER AND LOWER GUARDS MUST REMAIN IN PLACE FOR SAFE CUTTING OPERATION.

Control Locations

- A. On / Off Switch
- B. Miter Controls
- C. Miter Scale
- D. Bevel Controls
- E. Bevel Scale
- F. Column Clamp Handle
- G. Elevation Control
- H. Rip Controls
- I. Operating Handle
- J. Anti-kickback assembly

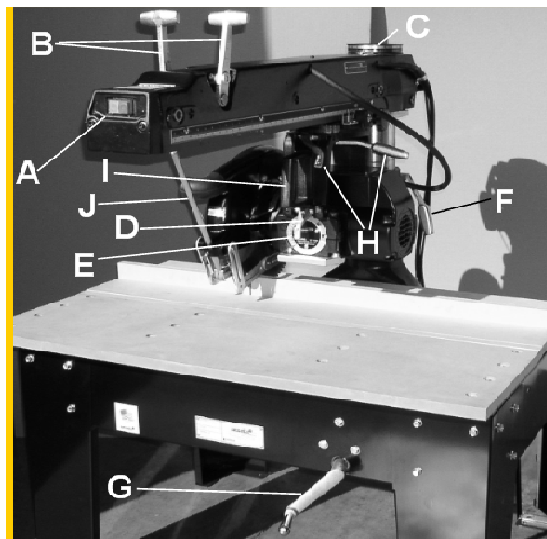

Raising and Lowering the Arm

When the column clamp handle is pulled forward, the elevating crank can be used to raise or lower the arm. Using the elevating scale and the indicator on the elevating crank, the desired depth of cut can be adjusted. Each calibration (1/8 turn) on the elevating scale raises or lowers the arm 1/64", therefore, one full turn of the elevating crank moves the arm exactly 1/8", one half turn exactly 1/16". The elevating crank can be removed to avoid any interference during the operation of the saw. Engage column clamp after elevating the desired amount.

To Revolve the Arm Horizontally

To change the position of the arm, pull both the miter latch handle and the arm clamp handle forward. Observing the miter scale, swing the arm either right or left to the desired angle. The arm can quickly be located at the 0 and 45 degree marks by using the locator slots machined into the column ring. When you have located the saw at the required position engage both the miter latch and the arm clamp by pushing the handles back.

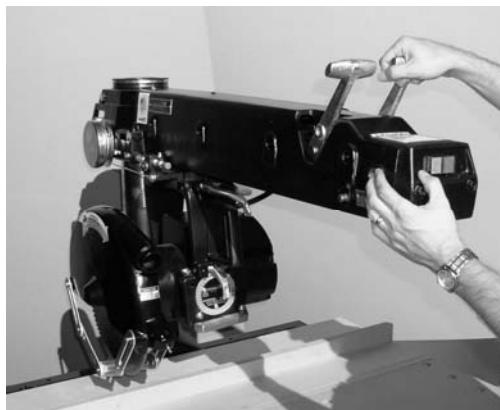

!!! CAUTION !!!
FOR ILLUSTRATION PURPOSES ONLY ,THE LOWER GUARD HAS BEEN REMOVED FOR THE PHOTOS USED IN THIS MANUAL. IN ACTUAL USE BOTH UPPER AND LOWER GUARDS MUST REMAIN IN PLACE FOR SAFE CUTTING OPERATION.

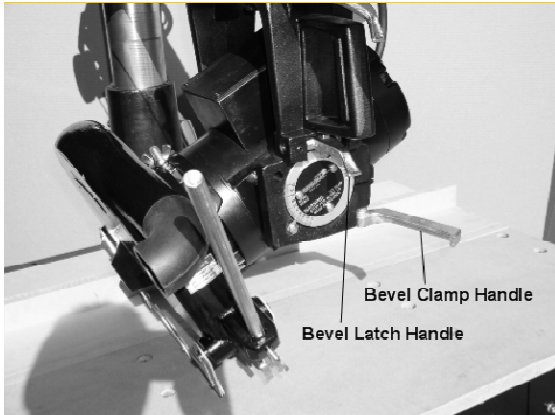

Revolving the Motor Vertically in the Yoke

Raise the arm to allow the saw blade sufficient clearance above the table top. Release the bevel clamp handle , grasp the saw guard with the left hand and lift the bevel latch handle. The motor can now be swung to a bevel position as indicated on the bevel scale. Lock the motor by engaging the bevel latch handle (possible only at 0°, 45° and 90°) and by locking the bevel clamp handle.

Cross Cutting

Lock the arm in the 0° position. Place the material securely against the guide strip– keep hands well away from the blade. Draw the saw blade across the material. After the cut has been completed return the blade behind the guide strip. Observe this order of operation for all cross cuts. Never push the saw blade into the material. Pull the blade slowly and firmly across the material from the rear of the arm using the operating handle. The saw blade should cut into the table about 1/ 16” when cutting through the material. Raise the anti-kickback to just clear the material being cut. Adjust for varying wood thickness or warped material.

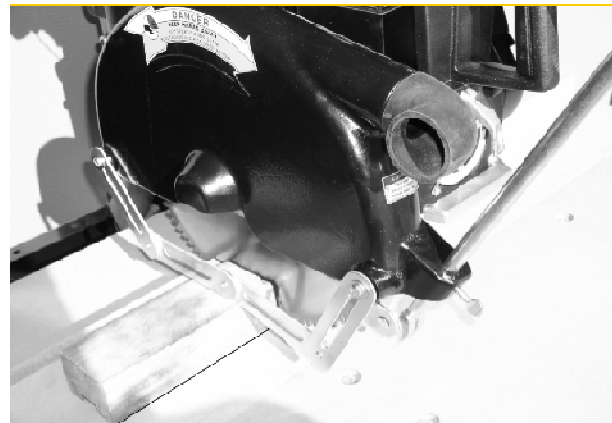

Adjusting the Saw Guard

The 16” guard can be pivoted about the motor by loosening the guard mounting wing nut.

The 20” guard can be pivoted about the guard bracket by loosening the two wing nuts on the motor side of the guard.

CAUTION—DO NOT ADJUST THE GUARD, OR ANTI-KICKBACK WHILE BLADE IS MOVING. KEEP ALL ADJUSTING MECHANISMS TIGHT.

Bevel Cutting

Lock the arm in the cross cutting position. Raise the motor by rotating the elevation crank. Release the bevel clamp and the bevel latch and tilt the motor in the yoke. The bevel angle is shown on the bevel scale. Lock the bevel latch and clamp. Lower the arm into cutting position. Adjust the bevel stop to assure clearance between blade and base. Pull the saw through as you would for cross cutting.

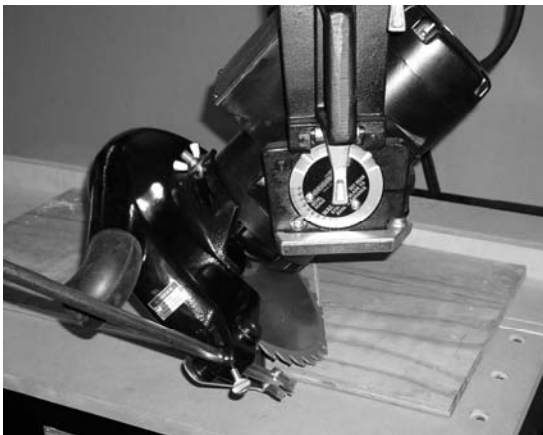

Compound Miter Cutting

The compound miter is merely a combination of the bevel cut and the miter cut. Set up the machine for bevel cutting. Release the arm clamp handle and the miter latch handle. Swing the arm into the required position and lock the miter latch and arm clamp. Adjust bevel stop to assure clearance between blade and base. Pull the blade through as you would for cross cutting.

!!! CAUTION !!!

FOR ILLUSTRATION PURPOSES ONLY, THE LOWER GUARD HAS BEEN REMOVED FOR THE PHOTOS USED IN THIS MANUAL. IN ACTUAL USE BOTH UPPER AND LOWER GUARDS MUST REMAIN IN PLACE FOR SAFE CUTTING OPERATION.

Maintenance Adjustments and Alignments

Caution! Disconnect and lockout power supply before making any adjustments or alignments.

Your saw has been completely assembled, aligned and tested at the factory...then partially disassembled for shipment. Handling during shipment may cause some misalignment and the following information will enable you to correct any cutting inaccuracy you discover. These adjustments may also be necessary after a period of use. (See preventive maintenance)

Important ...Since one adjustment may affect another it is important to run through the adjustments in the sequence as follows.

Adjustment of Base to Column Fit

If excessive side motion exists at the end of the arm when the arm clamp is engaged and the column clamp is released, adjustment to the base or bronze gib is generally necessary. To adjust:

1. Loosen all locknuts, setscrews and bolts and pull column clamp handle forward.
2. With the motor and yoke in the rearmost position the elevation effort should be easy.
3. Tighten the bottom pinch bolt (A) until there is an increase in the elevation effort. Bottom the jack screw (B) against the opposite side of the slot; this will lock the pinch bolt.
4. Tighten the gib screw (C) hard, then back it off. Run it back up against the gib lightly, then snug up the locknut (D).
5. With the column clamp handle in the forward position insert a 1/4" allen wrench into column clamp bolt (E) and turn it clockwise until all play is removed from the column clamp handle. Lock the handle adjustment by tightening the bolt (F) on the opposite side of the base.

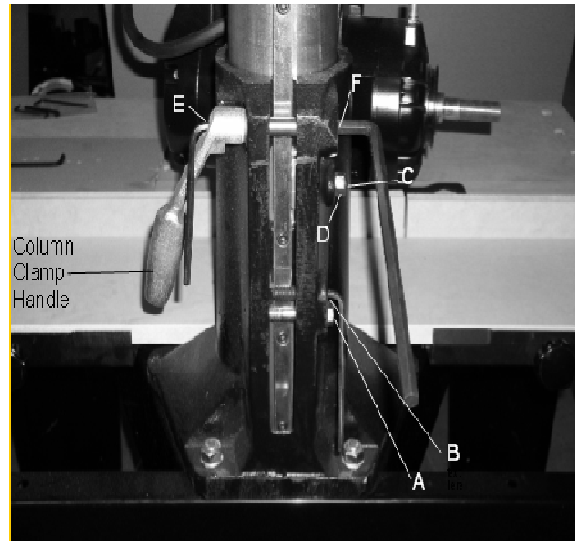

Adjustment of the Arm Clamp

If the arm will not clamp tight on the column:

1. Place motor carriage in the rearmost position.
2. Pull the miter handles (A) forward.
3. Tighten upper arm pinch bolt (B) until slight resistance to arm swing is felt.
4. Swing the arm to the left 10° until the two locking set screws (C) are aligned with an oblong hole in the bottom of the column collar (D).
5. Loosen the two set screws.
6. Use a 1/4" allen wrench to tighten the arm clamp screw (E) by rotating clockwise.
7. Retighten the two locking set screws securely to a required torque of 200-225 inch/ lbs. They must be tight to prevent clamp screw slippage.

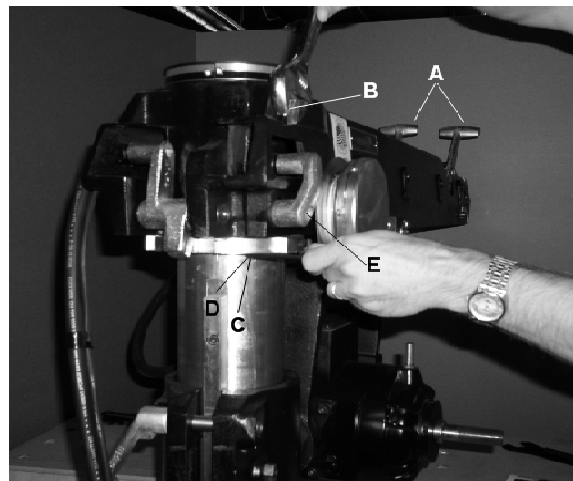

Adjustment of the Rollerhead to Arm

Accurate work cannot be done if the roller bearings of the motor carriage are not in proper adjustment. When play develops between the rollerhead and the arm the following adjustment is required:

1. Remove the arm end cap by taking out the two socket head cap screws in the front of the end cap.
2. Clean the tracks thoroughly. Wipe them clean with a solvent, **do not** use kerosene. Use extreme caution as most solvents are toxic and/or flammable. **Do not** grease or oil the tracks.
3. Loosen the locking set screws (A) on the two left hand 45° bearings (C) just enough to loosen them (1/6 of a turn or less).
4. Using a 1/4" allen wrench and a light behind the rollerhead, adjust the eccentric studs (B) on the left-hand side bearings until all 8 bearings contact the track. Attempt to equalize the load on the front and rear bearings by putting the same load on the front and rear eccentrics.

Adjustment of the Rollerhead to Arm (cont'd)

5. Retighten the locking set screw securely to a required torque of 90-100 inch/lbs., after adjusting each eccentric.
6. Replace the end cap
7. If any of the top rollers do not revolve when in contact with the top track it will be necessary to remove the entire carriage to closely check each roller bearing. If bearings do not revolve, and thorough cleaning doesn't make them all free to revolve, the defective ones should be replaced.

Note-Too much pressure on the roller bearings will cause excessive and unnecessary wear in the parts and make the carriage work harder. Seven to ten pounds average pull on the carriage is a desirable preload.

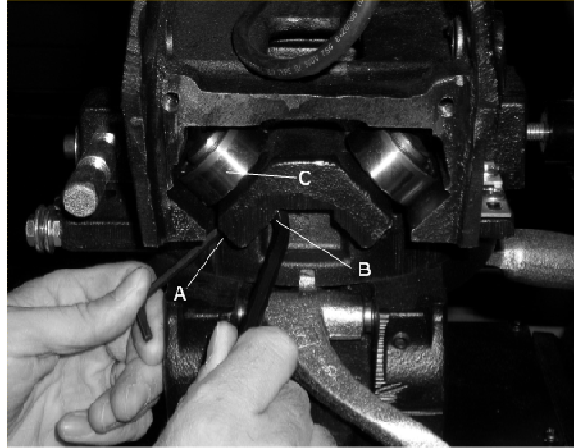

Adjustment of the Yoke Clamp Handle

If the yoke clamp handle (A) becomes too loose the following steps will correct this condition:

1. Pull yoke clamp handle forward.
2. Remove socket head cap screw (B) on the underside of the yoke.
3. Using the same allen wrench rotate the kingbolt (C) counterclockwise to tighten.
4. Replace the cap screw.

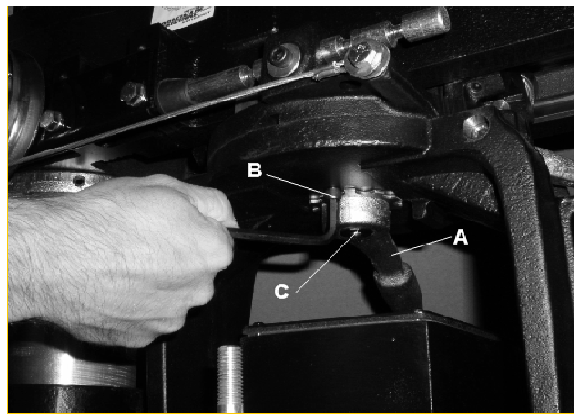

Adjustment of Table Top Parallel to Arm

The arm tracks must be parallel to the tabletop at all points. This assures uniform depth of cut, especially when dado cutting. Remove the blade and insert an arbor wrench or allen wrench between the saw arbor collars. Lower the wrench until it touches the tabletop. If the top is not level:

1. Locate the highest point by swinging the arm from side to side and moving the carriage back and forth on the arm.
2. Loosen the lock nuts beneath the table frame.
3. Raise the jack screws so as to bring the low parts of the tabletop level with the high spots.
4. Tighten the lock nuts beneath the table frame.

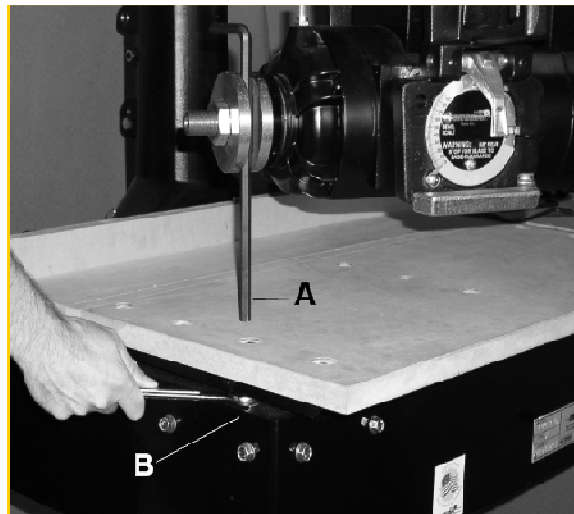

How to check the Guide Strip For Accuracy

For accurate work the guide strip must be straight. If the machine has been exposed to the weather or used for a period of time the wood parts may become warped or worn so that the guide strip is no longer straight. It should be made straight by planing and sanding. Check it with a straight edge or square before proceeding and make any adjustments necessary.

Caution! Disconnect and lockout power supply before making any adjustments or alignments.

To Square Saw Blade with the Table Top

Make sure the tabletop is level and place a steel square against the side of the blade; the square should be against the gullets and not the teeth of the blade. If the blade is not square to the tabletop:

1. Release the bevel clamp handle (A) and bevel latch (B).
2. Loosen the two set screws (C) in the front of the yoke locking the bronze bevel latch adjustment screws. (D).
3. Adjust the bevel latch adjustment screws by backing off one and tightening the other to move the blade flush to the square. Tighten the two locking set screws to a required torque of 90-100 inch/lbs.
4. After adjustment, the bevel latch should move freely but with no side play.
5. Engage the bevel latch and bevel clamp and re-check for square.
6. Adjust the bevel pointer washer (E) to line up with zero on the bevel scale.

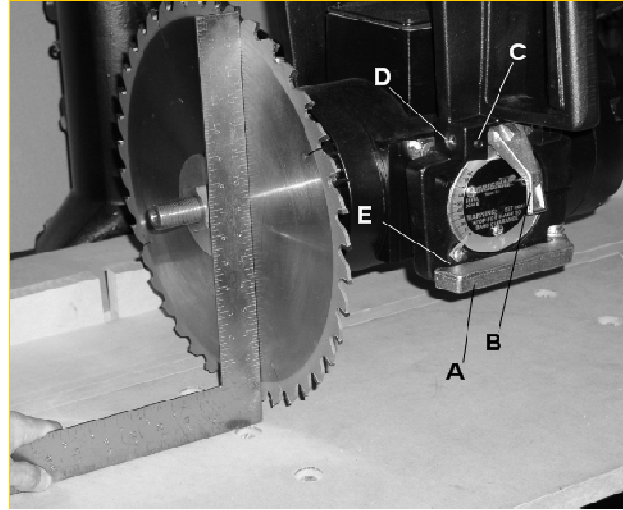

Adjustment of Rear Trunion and Bevel Clamp Handle

If the rear motor trunion is loose in the yoke, or if bevel clamp will not hold:

1. Loosen locking set screws (A in Figures 5 and 6) and bevel clamp (B in figure 5).
2. Tighten rear trunion pinch bolt (B, figure 6) until bevel movement becomes slightly difficult. Reset its locking set screw to a torque of 90–100 inch/lbs.
3. Tighten the bevel clamp stud (C in figure 5).
4. Tighten its locking set screw to 90-100 inch/lbs.

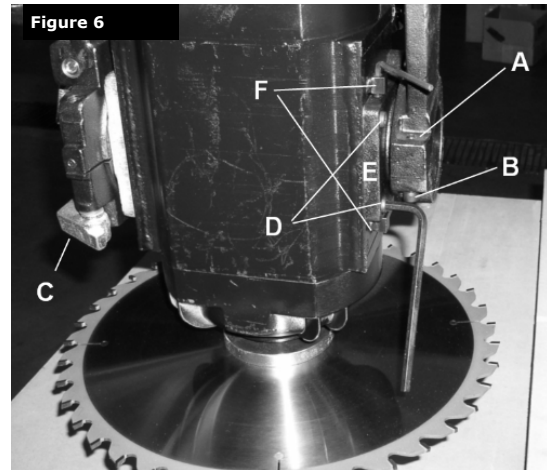
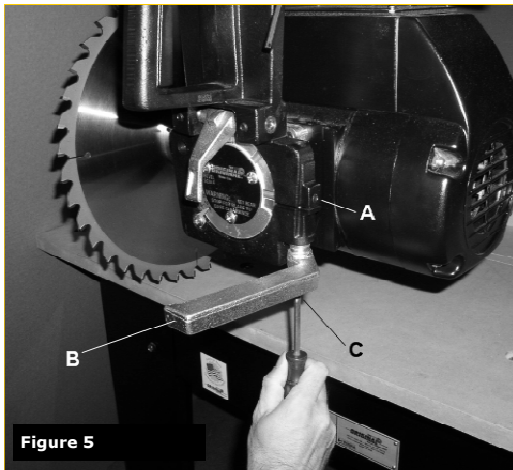

To Adjust for “Heel” (Saw Blade Not Parallel to Arm)

When the saw blade is not parallel to the arm the result will be what is called “heel” - the back of the blade will not follow in the kerf of the front of the blade. Signs of a blade heeling are indicated when the rear teeth of the blade mark the material with an offset in the cut. This condition can be noticed with by eye or with a straight edge. To correct this situation:

- A. First- --Adjust at the 90° Bevel Position**
 1. Put the motor into 90° bevel position. Engage both bevel latch and bevel clamp.
 2. Place a block about 5” high on the tabletop, ahead of and right of the arbor.
 3. Elevate and move the carriage until a saw tooth forward and to the right of the arbor just touches the block.
 4. Pull the carriage forward and turn the blade until the same tooth is over the same spot on the block. The tooth should just touch the block at each position. If it does not:
 - a. Release the bevel clamp (C in figure 6). Loosen the 4 cap screws (D in figure 6) holding the rear trunion (E, figure 6) to the motor. Move the rear trunion by means of the two set screws (F in figure 6) so the saw tooth just strikes the block in the 2 positions with the bevel clamp engaged. Retighten the cap screws to a required torque of 200–225 inch/lbs.

Steps 1–4 normally need be done only when rear trunion has been removed from motor.

To Adjust for “Heel” (Saw Blade Not Parallel to Arm) (cont’d)

B. Second - Adjust at the 0° Bevel Position

1. Put the motor into 0° bevel position. Engage bevel latch (A, Fig. 7) and bevel clamp (B).
2. Cross cut a piece of material and determine the side of the cut on which the teeth are heeling. Make a note which side of the cut material has heeling marks.
3. Pull the yoke clamp handle (C, Fig. 7) forward.
4. Release the rip swivel latch (D, Fig. 7).
5. Loosen the two set screws (E, Fig. 7) locking the bronze rip swivel latch adjusting screws (F, Fig. 7).
6. If the heel marks were on the right side of the material loosen the adjusting screw on your left and tighten the one on the right. If the marks were on the right of the material tighten the adjusting screw on your left and loosen the one on your right.
7. Tighten the two locking set screws to a required torque of 90–100 inch/lbs.
8. The rip swivel latch must move freely without side play.
9. Engage rip swivel latch and lock the yoke clamp, recheck the crosscut and make additional adjustment if necessary.

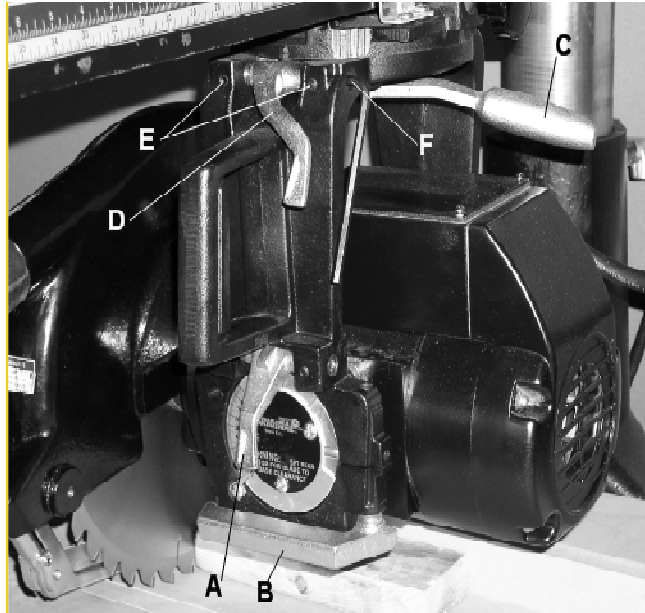

Figure 7

If after making these adjustments the blade continues to heel, particularly if the blade heels on both sides of the material, the blade may require tensioning. If the blade must be re-tensioned contact your local distributor.

Square the Saw Travel with the Guide Strip

Engage the miter latch, miter clamp and column clamp. Place a steel square against the guide strip, flat on the tabletop. If the blade does not move parallel to the square as the carriage is moved forward the following adjustments are in order:

1. Pull miter handles (A) forward.
2. Loosen the two set screws (B) on the bottom of the rear of the arm that lock the bronze miter latch adjusting screws (C).
3. If the blade moved **toward the square** when pulled, loosen the adjusting screw on the right and tighten the one on the left (as viewed from the front). If the blade movement was **away from the square** then tighten the adjusting screw on the right and loosen the left.
4. Tighten the two locking set screws to a required torque of 200– 225 inch/lbs.
5. The miter latch must have no side play after adjusting.
6. Make a final check of square with the column clamp, miter latch and miter clamp engaged.

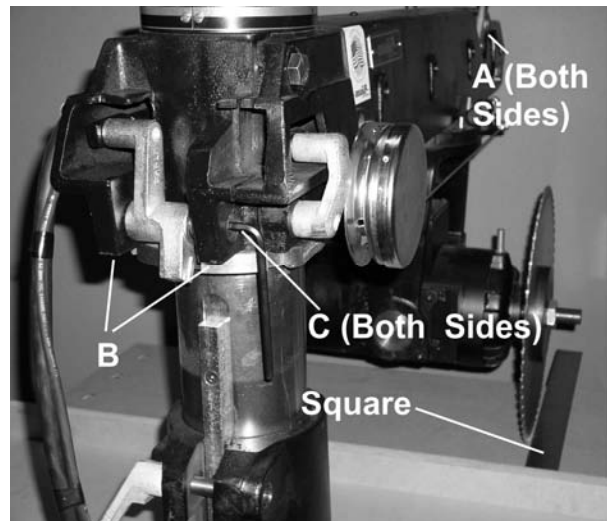

Adjustment of Miter, Bevel and Swivel Latches

If a loose condition ever develops between the miter, bevel or swivel latches and their respective adjusting screws, refer back to the following sections for adjustment. Miter Latch above, Bevel Latch page 14 and Rip Swivel Latch above. Be sure to check alignment after adjusting latches.

Caution! Disconnect and lockout power supply before making any adjustments or alignments.

Bevel Stop Rod

The bevel stop rod (A) is a device mounted on the roller-head to prevent the blade from contacting the base when the bevel cuts are being made; particularly with 20" blades. A socket head cap screw (B) locks the rod into position. BEFORE MAKING BEVEL CUTS ALWAYS BE CERTAIN THE BEVEL STOP ROD IS POSITIONED SO THE BLADE CLEARS THE BASE WITH THE MOTOR IN ITS REAR POSITION.

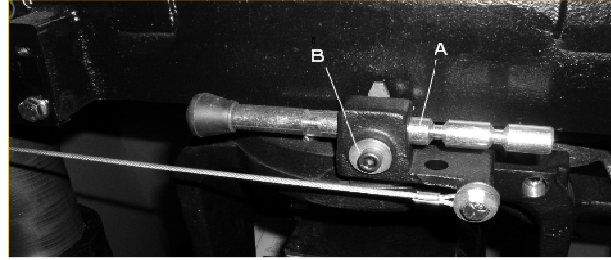

Adjustment of Miter Scale

The miter scale is located at the rear of the arm. When the arm is positioned for straight cross cutting, the pointer should be a 0° on the scale. To adjust, loosen the screw holding the pointer and adjust to 0°. Retighten the screw.

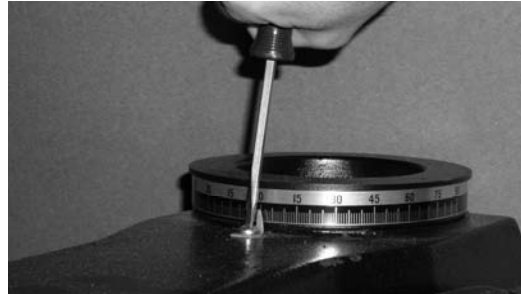

Adjustment of Bevel Scale

The bevel scale is located at the front of the yoke. When the motor is positioned for straight cross cutting the pointer should be at 0° on the scale. To adjust, loosen screw and move pointer to 0° and tighten.

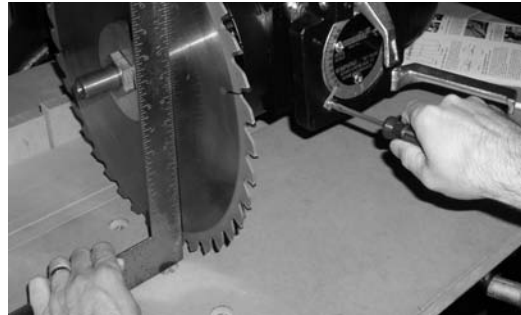

PARTS LIST AND ORDERING INSTRUCTIONS

Order only genuine parts from your Original Saw Company Dealer. With your order be sure to include:

1. Name of Manufacturer: The Original Saw Company.
2. Complete machine identification data (from name plate on the front of the table frame).
3. Complete motor identification data (from motor name plate).
4. Quantity, part number, and description of parts required.
5. Complete shipping and billing instructions.

Because of the importance of tightening critical bolts and set screws to an established torque, each of the following parts lists pages contains torque tightening requirements for certain fasteners. These fasteners have their part numbers circled and torque requirements specified.

If parts should be replaced, information is supplied on these same parts lists where lubrication would be desirable. Such areas are marked with a 'G'; general purpose grease can be used.

16" METAL CUTTING GUARD

Ind No.	Part No.	Description	Qty
1	090531	16" Upper Guard Assembly	1
2	090527	Rotation Label	1
3	123716	Latch	1
4	099248-06	8-32 x 3/8 Pan Hd Screw	2
5	000407	8-32 Hex Nut	2
6	000418	#8 Lockwasher	2
7	099358-08	5/16 Flat Washer	1
8	082007	Wing Nut	1
9	090528	Label	1
10	080155	Bolt	4
11	084173	1/4" Lockwasher	4
12	123539	Danger Label - Noise	1
13	123541	Danger Label - Cutting Tool	1

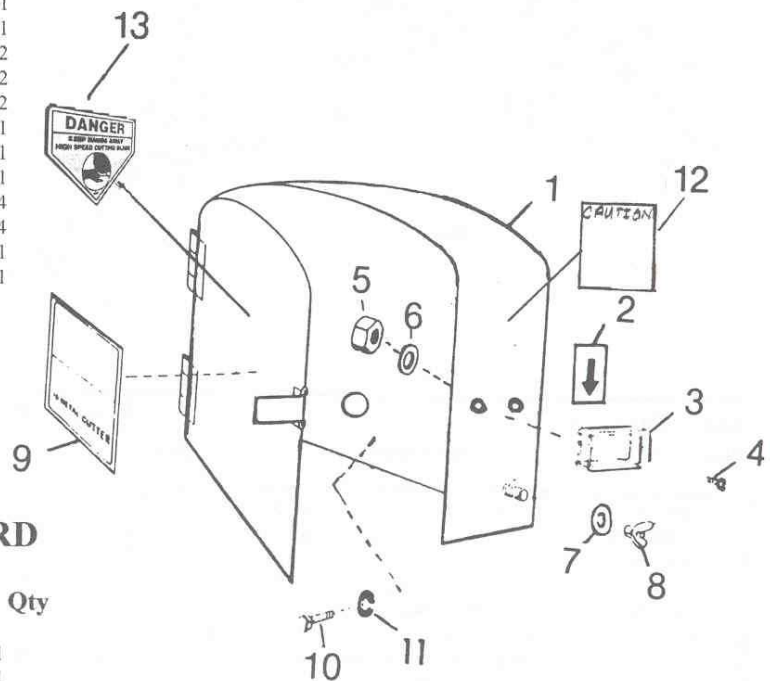

20" METAL CUTTING GUARD

Ind No.	Part No.	Description	Qty
1	090533	20" Upper Guard Assembly	1
2	090527	Rotation Label	1
3	123716	Latch	1
4	099248-06	8-32 x 3/8 Pan Hd Screw	2
5	000407	8-32 Hex Nut	2
6	000418	#8 Lockwasher	2
7	099358-08	5/16 Flat Washer	1
8	082007	Wing Nut	1
9	090528	Label	1
10	080155	Bolt	4
11	084173	1/4" Lockwasher	4
12	123539	Danger Label - Noise	1
13	123541	Danger Label - Cutting Tool	1

Arm Assembly

52"- 800420-02

44"- 800410

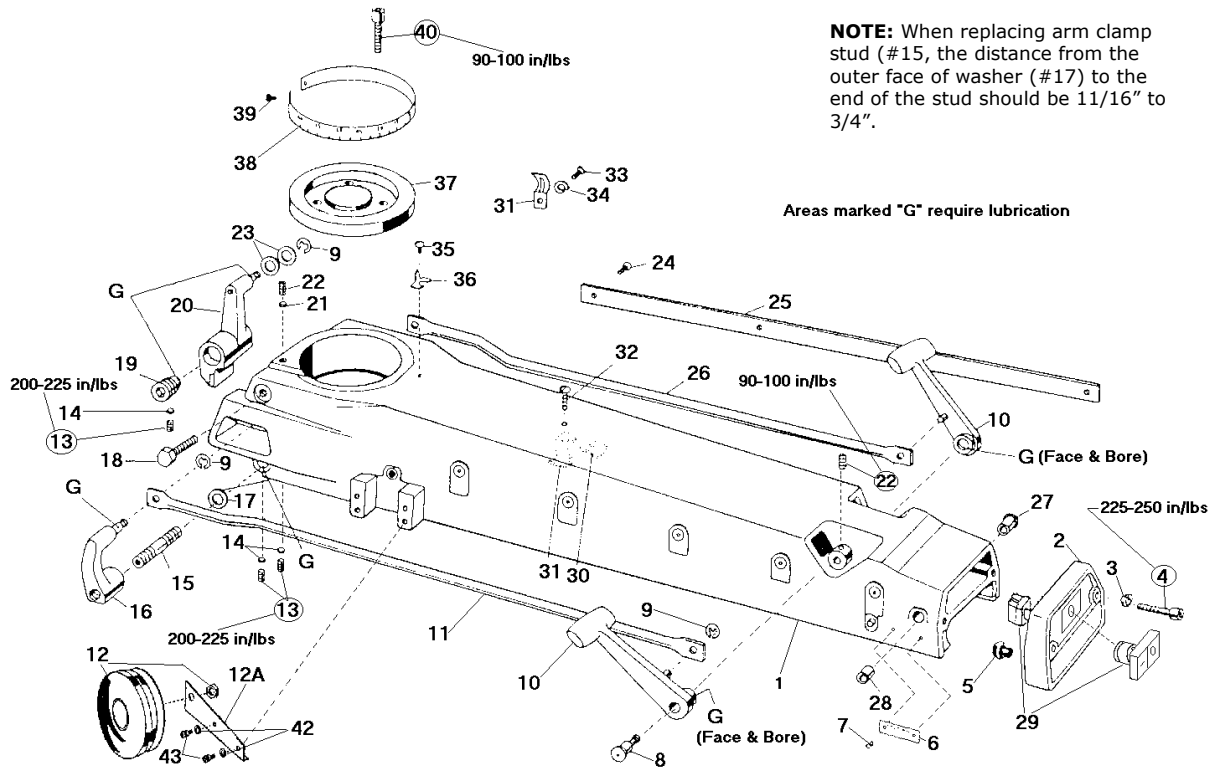

NOTE: When replacing arm clamp stud (#15, the distance from the outer face of washer (#17) to the end of the stud should be 11/16" to 3/4".

Areas marked "G" require lubrication

Index No.	Part No.	Description	Qty	Index No.	Part No.	Description	Qty
1	068545-01	Arm (52")	1	24	099264-06	1/4-20 x 3/8 Panhd Screw (52")	5
1A	068545-00	Arm (44")	1	25	068490	1/4-20 X 3/8 Panhd Screw (44")	4
2	068190-04	End Cap	1	25A	068395	Rip Scale (16" Long 52")	1
3	084319	5/16 Lockwasher	2	25B	068490-01	Rip Scale (20" Long 52")	1
4	082179	5/16-18 x 2 Sckthd Cap Screw	2	25C	068395-01	Rip Scale (20" Med 44")	1
5	070871	End Cap Bumper	1	26	068188-02	Miter Latch Rod (52")	1
6	103117	Arm Caution Plate	1	26A	068188-01	Miter Latch Rod (44")	1
7	003041	#2 3/16 Drive Screw	1	27	070258	Flanged Bushing	2
8	068634	Concentric Shaft	2	28	068955	Sleeve Bushing	2
9	058529	Retaining Ring	4	29	900101-02	Switch Kit -Square Button	1
10	068589	Miter Handle	2	30	071684	Clamp Nut	1
11	068189-01	Miter Clamp Rod (44")	1	31	081778	Cable Clamp	1
11A	068189-02	Miter Clamp Rod (52")	1	32	082354	1/4-20 x 2 Roundhead Screw	1
12	066210	Auto Return Reel	1	33	080634	1/4-20 x 1/2 Roundhead Screw	1
12A	084963	Auto Return Bracket	1	34	084173	1/4 Lockwasher	1
13	068967	3/8-16 x 1/2 Set Screw	4	35	099264-06	1/4-20 x 3/8 Panhead Screw	1
14	068077	Set Screw Slug	4	36	203597-09	Miter Pointer	1
15	068424	Arm Clamp Stud	1	37	122458-01	Miter Cap	1
16	068591	Miter Clamp	1	38	068567	Miter Scale	1
17	122051	Flat Washer	1	39	099249-06	10-24 x 5/16 Panhead Screw	2
18	082115	5/8-11 x 3/4 Hexhd Cap Screw	1	40	082190	1/4-20 x 1 Sockethead Cap Screw	3
19	068262	Adjustment Screw	2	41	081777	Cable Clamp (not shown)	1
20	068590	Miter Latch	1	42	000415	3/8 Lockwasher	2
21	083412	Set Screw Slug	1	43	082098	3/8-16 x 3/4 Hexhead Bolt	2
22	068703	5/16-18 x 1/2 Set Screw	3				
23	082488	Flat Washer	2				

Manual Chain Feed Assembly

52"- 040022

44"-040021

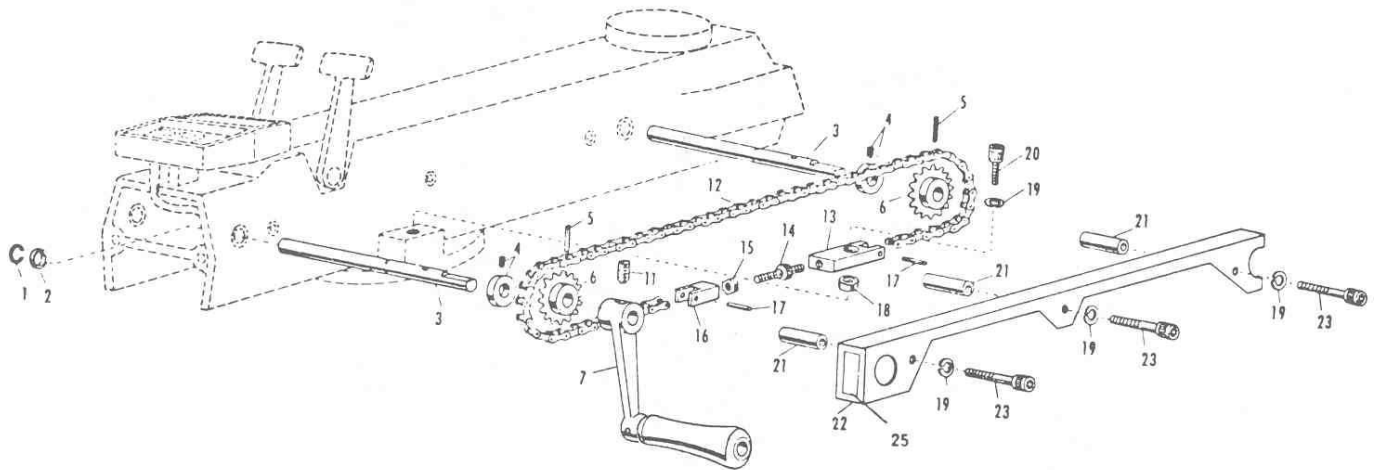

XX

Ind No.	Part No.	Description	Qty	Ind No.	Part No.	Description	Qty
1	071252	Retaining Ring	2	14	068259	Turnbuckle	1
2	068955	Spacer Bushing	1	15	099364-04	5/16-18 Hex Nut	1
3	085182	Crank Shaft	2	16	068256	Left Hand Clevis	1
4	084145	Collar	2A	17	123615	13/64 x 1 Pin	2
5	099210-24	3/16 x 1 1/2 Roll Pin	2	18	068258	Spacer	1
6	084139	Sprocket	2	19	099384-07	5/16 Lockwasher	4
7	070964	Crank Handle Assembly	1	20	099155-24	5/16-18 x 1 1/2 Soc Hd Cap Scr	1
11	082392	3/8-16 x 3/8 Cup Pt Set Screw	1	21	070955	Spacer	3
		CHAIN ASSEMBLIES:	1			CHAIN GUARDS:	
12	068261-01	Assy for 52" arm incl 13,16,17		22	071260-01	Chain Guard 52" Arm	1
	068261-00	Assy for 44" arm incl 13,16,17			071260-00	Chain Guard 44" Arm	1
13	068257	Right Hand Clevis	1	23	082181	5/16-18 x 2 1/2 Soc Hd Cap Scr	3

Rollerhead Assembly

800500-02

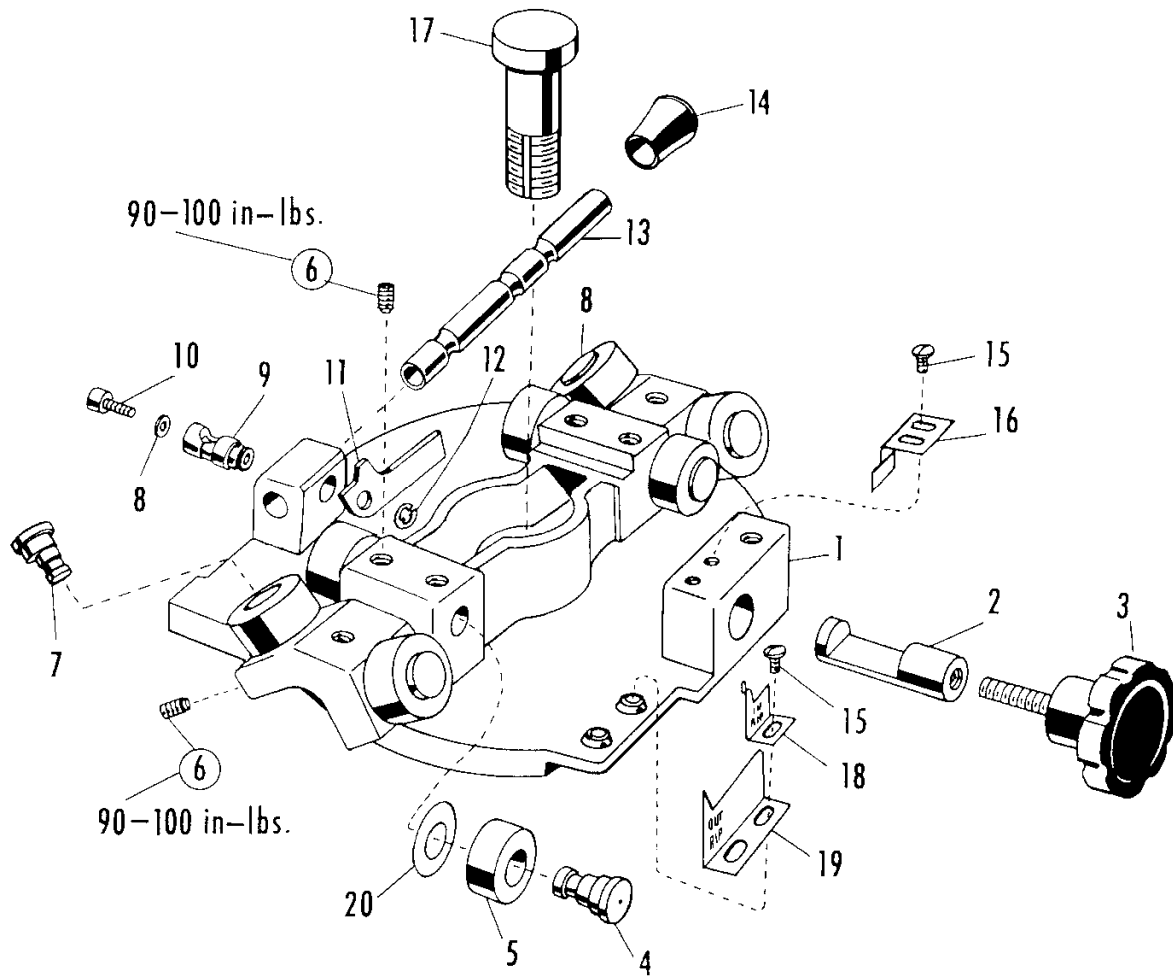

Item #2 and #3 are not used in 3579 Metal Cutter or 40005 Power Crossfeed

Index No.	Part No.	Description	Qty	Index No.	Part No.	Description	Qty
1	068632	Rollerhead	1	11	070270	Stop Plate	1
2	068636	Rip Lock	1	12	058529	Retaining Ring	1
3	068654	Locking Knob	1	13	068263	Bevel Stop Rod	1
4	068634	Concentric Shaft	6	14	068653	Bumper	1
5	081476-01	Ball Bearing	8	15	099264-06	1/4-20 x 3/8 Panhd Screw	2
6	068703	5/16-18 x 1/2 Set Screw	8	16	068635	Shoe	1
7	068633	Eccentric Shaft	2	17	067927	King Bolt	1
8	099358-08	Flat Washer	1	18	068527	In Rip Pointer	1
9	070269	Bevel Stop Lock	1	19	068348	Out Rip Pointer	1
10	080590	5/16-18 x 1 3/4 Sochd Cap Screw	1	20	103422	Bearing Shaft Washer	8

Yoke and Trunion Assembly

800300

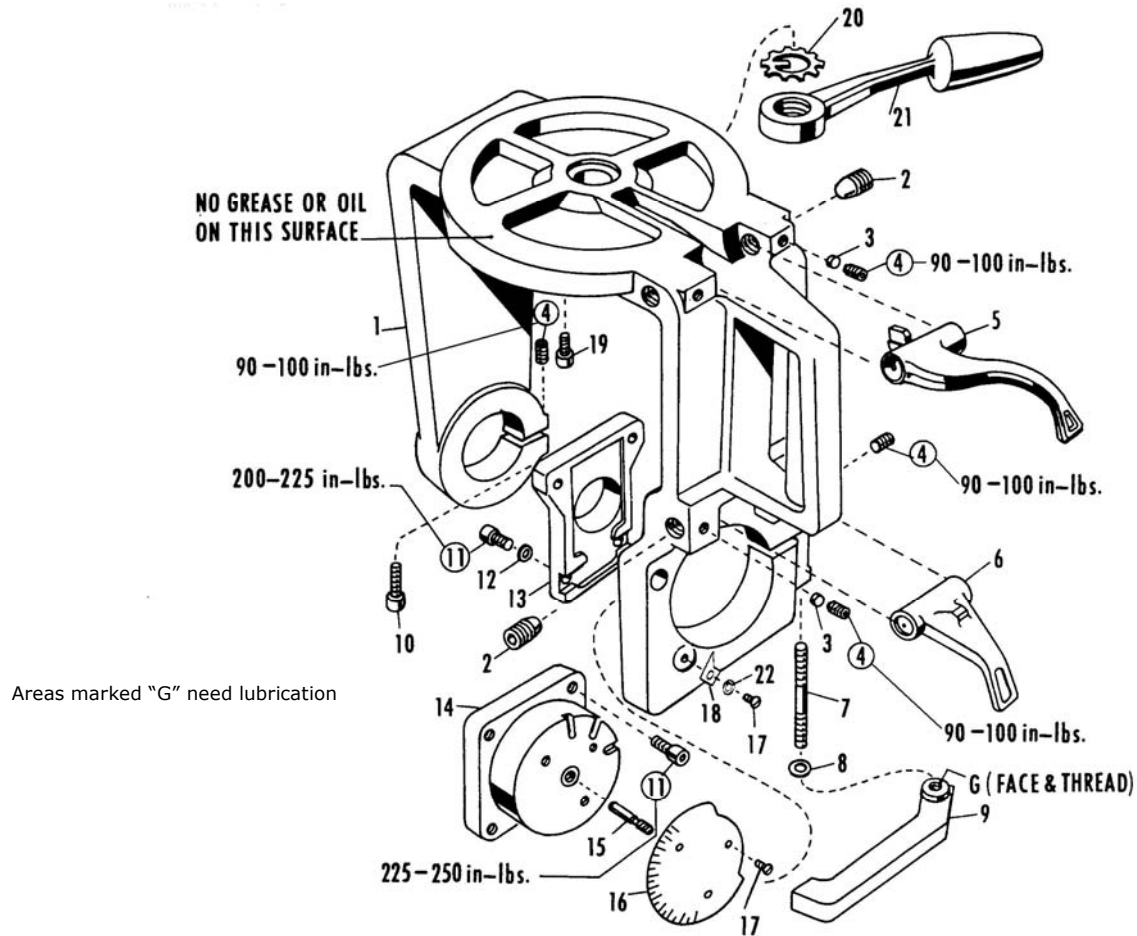

Important:

1. Bevel clamp #7 should be adjusted flush to 1/8" inside bottom of Bevel Clamp Handle #9
2. Turn front trunion #14 counterclockwise as far as it will go before tightening screws #11.

Index No.	Part No.	Description	Qty	Index No.	Part No.	Description	Qty
1	068622	Yoke	1	12	203085	special washer	4
2	068626	Adjusting Screw	4	13	068624	Rear Trunion	1
3	083412	Set Screw Slug	6	14	068623	Front Trunion	1
4	068703	5/16-18 x 1/2 Set Screw	6	15	068631	Dowel Screw	1
5	068627-01	Swivel Latch Handle	1	16	073872	Bevel Scale	2
6	068628-01	Bevel Latch Handle	1	17	099264-06	1/4-20 x 3/8 Panhd Screw	4
7	068625	Stud	1	18	203588-01	Bevel Pointer	1
8	114720	1/2 Flat Washer	1	19	082200	5/16-18 x 3/8 Sochd Cap Scrw	1
9	068629-01	Bevel Clamp Handle	1	20	068655	Adjuster Washer	1
10	082172	5/16-18 x 1 1/4 Sochd Cap Screw	1	21	096775	Yoke Clamp Handle	1
11	082168	5/16-18 x 1 Sochd Cap Screw	8	22	084173	1/4 Lockwasher	1

Base and Column Assembly

800200-02

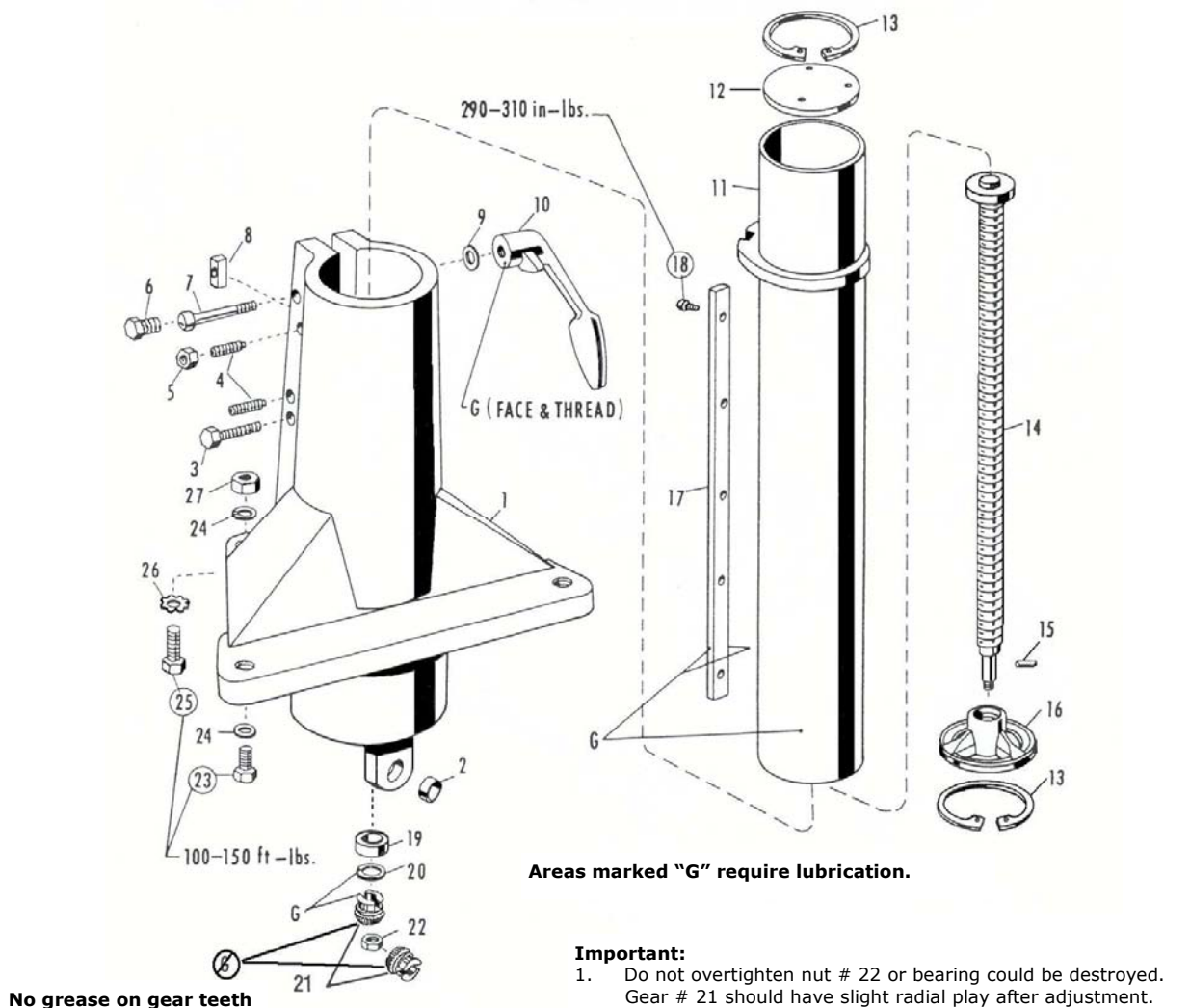

Areas marked "G" require lubrication.

Important:

1. Do not overtighten nut # 22 or bearing could be destroyed. Gear # 21 should have slight radial play after adjustment.
2. After tightening screws #18 slightly, seat key #17 against shoulder of column #11 and tighten screws to required torque.

No grease on gear teeth

Index No.	Part No.	Description	Qty	Index No.	Part No.	Description	Qty
1	068649-00	Column Base	1	15	039746	Roll Pin	1
2	068955	Sleeve Bearing	1	16	068642-01	Elevating Nut	1
3	099187-56	1/2-13 x 3 1/2 Hexhd Cap Screw	1	17	068645	Key	1
4	068651	1/2-13 x 2 Set Screw	1	18	082205	5/16-18 x 5/8 Sochd Cap Scrw	5
5	081959	1/2-13 Hex Nut	1	19	063564	Bearing	1
6	068824	Lock Screw	1	20	068647	Thrust Washer	1
7	068643	Clamp Screw	1	21	061382	Bevel Gear Set	1
8	068644	Gib	1	22	032492	Elastic Stop Nut	1
9	122051	Flat Washer	1	23	082111	5/8-11 x 1 1/2 Hexhd Cap Scrw	2
10	068648-01	Clamp Handle	1	24	080682	5/8 Lock Washer	1
11	073878	Column	1	25	082122	5/8-11 x 2 1/4 Hexhd Cap Scrw	1
12	068646	Column Insert	1	26	082525	5/8 Star Washer	2
13	099022-04	Retaining Ring	1	27	081960	5/8-11 Hexhead Nut	2
14	068641	Elevating Screw	1				

Table & Frame Assembly

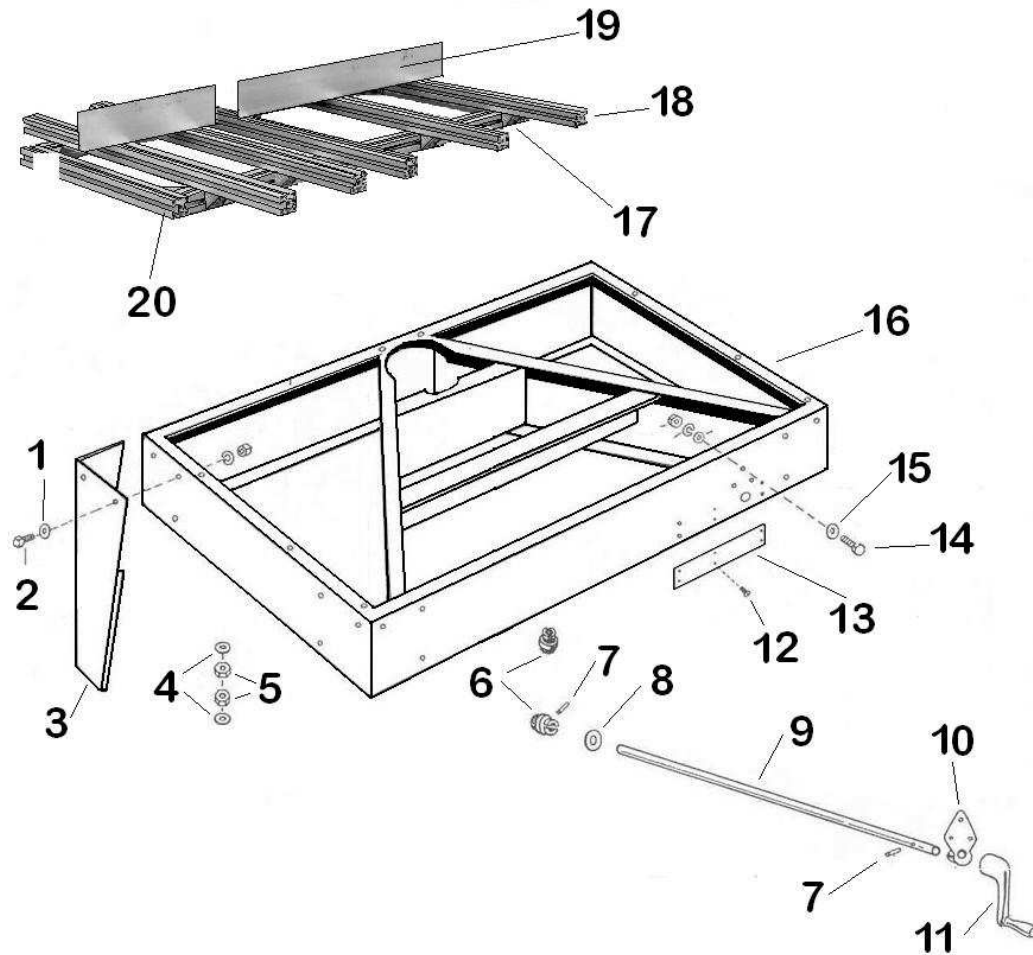

Index No.	Part No.	Description	Qty	Index No.	Part No.	Description	Qty
1	080674	3/8 Flat washer	80	11	090524	Elevating Handle	1
2	082102	3/8-16 x 1 flanges cap screw	24	12	012122	Drive Screw	4
3	083165	Leg	4	13	123459	Nameplate	1
4	080674	3/8 Flat Washer		14	082104	5/16-18 x 1 HHB	3
5	084180	3/8 heavy hex nut	80	15	099358-08	5/16 Flat Washer	3
6	061382	Bevel Gear Set (incl#6, 7, 8)	1	16	068659	Table frame	1
7	063382	3/169 x 1 1/4 roll pin	2	17	050110-00	gusset kit w/ fastener	14
8	068647	Thrust Washer	2	18	203490-09	t-slot rail	5
9	068670	elevating shaft	1	19	T1655	--- optional equip not included	
10	068708-01	Elevating bracket	1	20	090545-01	leveling frame	1

Motor Assembly

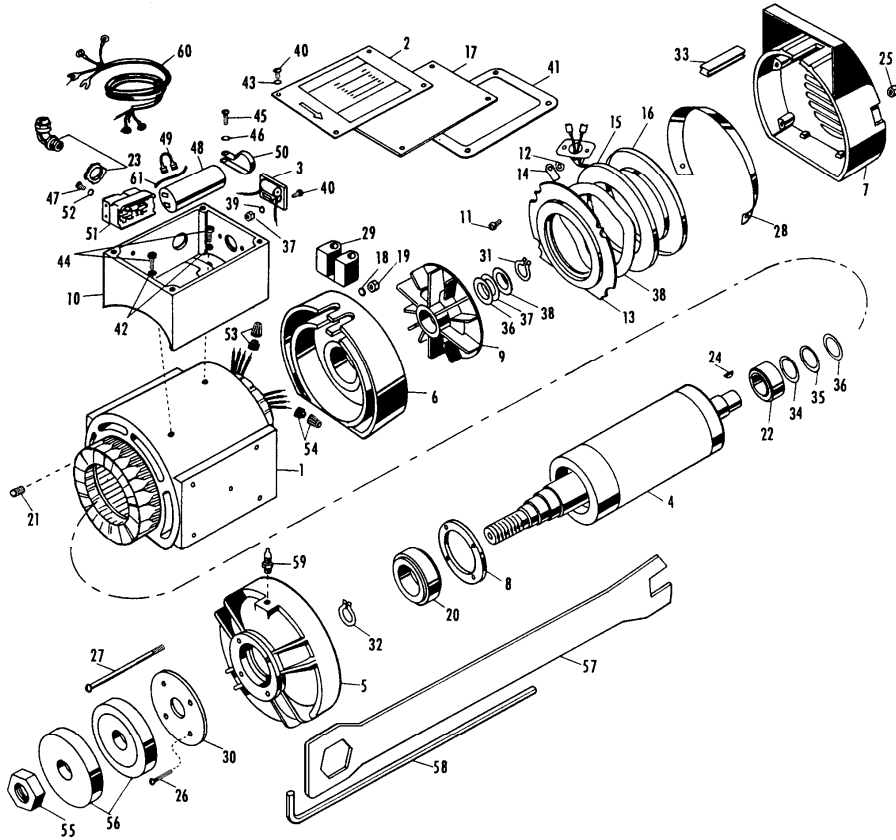

Each motor assembly includes items 1 through 61 depending on the phase of the motor.

5 HP 1 PHASE 230 V - 123504

7.5 HP 3 PHASE 230/460 V - 123505-00

7.5 HP 3 PHASE 575 V - 123505-01

7.5 HP 3 PHASE 208 V - 123505-03

Motor Assembly

5 HP 1 PHASE 230 V - 123504

7.5 HP 3 PHASE 230/460 V - 123505-00

7.5 HP 3 PHASE 575 V - 123505-01

7.5 HP 3 PHASE 208 V - 123505-03

In-dex	5 HP 1 PH	7.5 HP 3 PH	Description	Qty	In-dex	5 HP 1 PH	7.5 HP 3 PH	Description	Qty
1	068554-56		Stators: 230 v 60 cycle	1	34	542004	542004	Shim Washer	AR
		068556-90			35	542252	542252	Shim Washer	AR
		068556-93			36	083799	083799	Shim Washer	AR
		068556-96			37	000407	000407	#8-32 Hex Nut	2
					38	083399	083399	Brake Spring	1
2	070266-00	070266-20	Motor Nameplate	1	39	000418	000418	#8 Lock washer	2
3	072222	072222	Brake Module	1	40	099262-10	099262-10	8-32 x 5/8 Screw	4/2
4	123503-01	123503-01	Rotor & Shaft	1	41	067687	067687	Gasket	1
5	083384	083384	Arbor End Bell	1	42	000417	000417	#10 Lock Washer	2
6	072227-01	072227-01	Fan End Bell	1	43	000418	000418	# 8 Lock Washer	4
7	083387	083387	Fan Housing	1	44	096994	096994	10-24 x 2 Phil Panhd	2
8	083419	083419	Bearing Cap	1	45	99249-05		10-24 x 3/8 Panhd Mach	1
9	096603	096603	SD Motor Fan & Liner	1	46	099384-07		5/16 Lock Washer	1
10	068293-02	068293-01	Conduit Box	1	47	099262-10		8-32 x 5/8 Screw	2
11	697162	697162	10-24x3/8 Sochd Cap Scrw	4	48	083382-01		Capacitor	1
12	000417	000417	10-24 Lock Washer	4	49	123484		Capacitor Lead	1
13	083396	083396	Brake Disk	1	50	068873		Capacitor Clamp	1
14	068532	068532	Retainer	4	51	068595-01		Relay	1
15	068593	068593-01	Brake Coil	1	52	000418		# 8 Lock Washer	2
16	070081	070081	Coil Housing	1	53	081733	081733	Wire Connector	4
17	067686	067686	Conduit Box Cover	1	54		081730	Wire Conn Brake Lead	6
18	084173	084173	1/4" Lockwasher	4	55	081433	081433	Arbor Nut	1
19	038738	038738	1/4-20 Hex Nut	4	56	081401	081401	Arbor Collar	2
20	123413	123413	Ball Bearing	1	57	301020-02	301020-02	Arbor Wrench	1
21	068703	068703	5/16-18 x 1/2 Soc Set Scrw	2	58	203511	203511	Wrench	1
22	123506	123506	Ball Bearing	1	59	103859	103859	Guard Stud	1
23	068820-07	068820-07	3/4 NPT Nut	1	60			Motor Cables:	
24	026587	026587	Woodruff Key	1		096725		208/230V 1 Ph 60 Hz	1
25	066966	066966	1/4-20 Hex Cap Nut—Brass	4			096780	208-575V 3 Ph 50/60 Hz	1
26	082323	082323	10-24 x 1 3/8 Flathead Scr	4	61	123485		Capacitor Jumper	1
27	083388	083388	Tie Rod	4					
28	083932	083932	Air Baffle	1					
29	072701	072701	Lead Grommet	1					
30	070786	070786	Cover Plate	1					
31	542253	542253	Retaining Ring	1					
32	541351	541351	Retaining Ring	1					
33	083898	083898	Slot Bushing—Rubber	1					

Magnetic Starter Assembly (telemecanique starter)

5 HP 1 PHASE 208/230 V - 700750-01

7.5 HP 3 PHASE 208/230 V - 700748-01

7.5 HP 3 PHASE 575 V - 700742-02

7.5 HP 3 PHASE 460 V - 700744-01

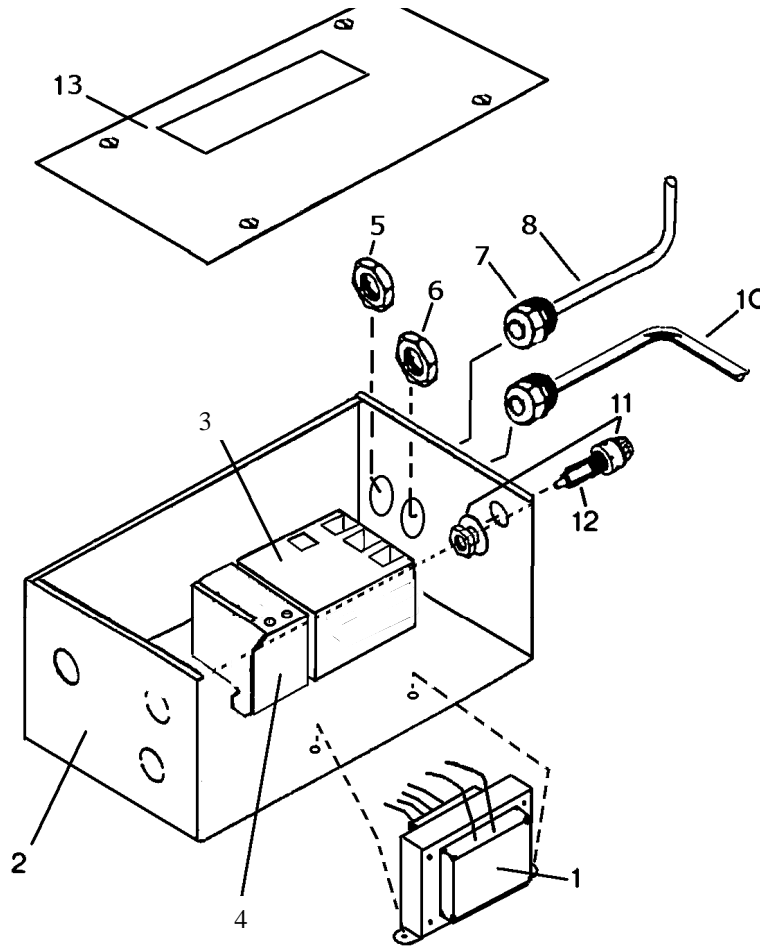

Index No.	Description	Qty	7.5 HP 3 Phase	5 HP 1 Phase
1	Transformer 208/230/460 volt 380/575 volt	1	122105-50 122105-51	122105-50 n/a
2	Enclosure	1	096759-04	096759-04
3	Magnetic Starter	1	122108-63	122108-63
4	Overload Block	1		
	208v 1 phase		—	122110-87 set to 30.8
	230v 1 phase		—	122110-87 set to 28
	208v 3 phase		122110-87 set to 24.2	—
	230v 3 phase		122110-87 set to 23	—
	460v 3 phase		122110-85 set to 12	—
5	Nylon nut 3/4	1	068820-02	068820-02
6	Nylon nut 1/2	1	068820-03	068820-03
7	Liquid tight fitting 3/4	1	081724-01	081724-01
8	Motor cable	1	096780-00	096725-00
9	Liquid tight fitting 1/2	1	066425-01	066425-01
10	Control cable	1		
	44" arm		068710-00	068719-00
	52" arm		068710-01	068710-01
11	Fuse holder	1	068723	068723
12	Fuse	1	081554	081554
13/14	See # 11			
15	Seal	2	066045-01	066045-01
16	Seal	2	066045-03	066045-03
17	Warning label	1	123540	123540

Changing the Motor Voltage

WARNING—DISCONNECT AND LOCKOUT POWER BEFORE SERVICING

If your machine requires a different voltage, follow the instructions below. The motor will need to be rewired according to the diagrams on the following pages. The thermal overloads must be replaced with the proper pieces to maintain thermal motor protection.

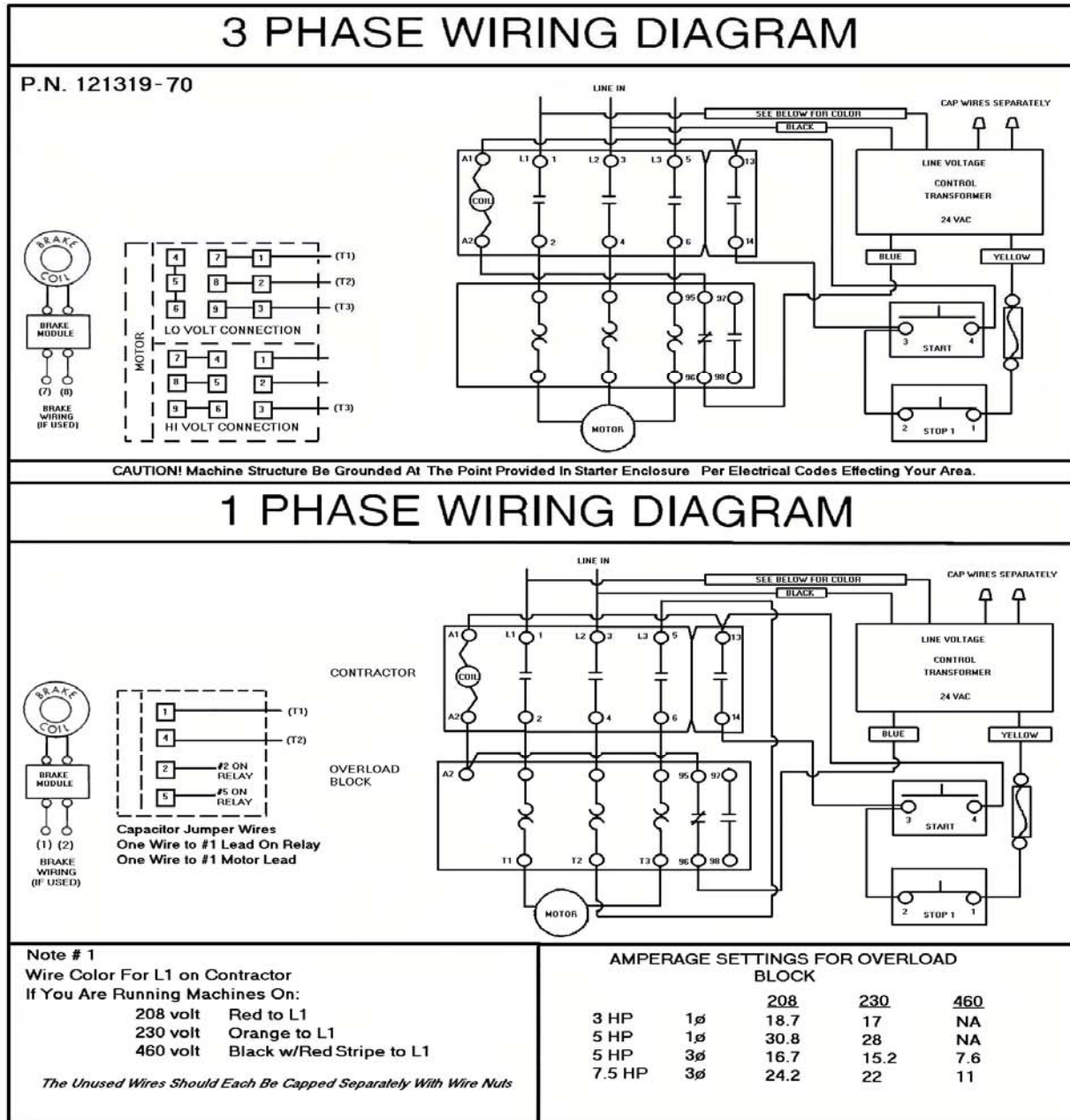

Instructions for Changing the Motor Voltage

- 1) **Disconnect and lockout power**– Electrical shock could occur if this is not done.
- 2) Reconnect motor and transformer leads as shown in the chart above to match your required voltage.
- 3) Reset the dial for the proper amperage setting shown in the chart above. If your overload block does not have the proper settings, the block will have to be replaced with one appropriate for your voltage.
- 4) Recheck all connections and replace lids on the motor box and magnetic starter enclosure before restoring power.

Alignment Guide for Accurate Cutting

The following guide is provided for your convenience. A saw that is not properly adjusted will not yield the desired accuracy and quality of cut. It should be noted any adjustment made will effect another, therefore it is best to perform all of the adjustments when correcting any one problem.

PROBLEM	POSSIBLE CAUSE	SOLUTION
Saw will not make a square cross cut or a good 45° miter cut	<ul style="list-style-type: none"> - Arm is not perpendicular to guide fence - Arm has excessive play at end - Column is loose in base - Too much play between arm and column - Rollerhead loose in arm (left to right play) - Yoke loose when clamped to rollerhead - Sawdust between lumber and guide fence - Table not parallel with arm - Guide fence not straight/rear edge of fixed board not straight 	<ul style="list-style-type: none"> - Adjust cross cut travel with guide fence - Tighten adjusting screws - Make proper adjustment (p.12) - Make proper adjustment (p. 12) - Adjust rollerhead (p. 12) - Adjust yoke clamp handle (p.13) - Clean tabletop - Make proper adjustment (p.13) - Replace fence/sand or replace (p.13)
Lumber has a tendency to walk away from fence when ripping or ploughing	<ul style="list-style-type: none"> - Saw blade is not parallel with fence - Arm not perpendicular to guide fence - Dull blade or cutters 	<ul style="list-style-type: none"> - Make heel adjustment (p. 14) - Adjust crosscut travel with guide fence (p. 15) - Sharpen or replace blade
Saw stalls when ripping or ploughing	<ul style="list-style-type: none"> - Fence not straight - Feed rate too fast - Wrong blade - Column too loose in base - Too much play between arm and column - Rollerhead loose in arm - Yoke loose when clamped to rollerhead - Sawdust between lumber and fence 	<ul style="list-style-type: none"> - Replace fence - Slow feed rate - Use correct blade - Make proper adjustment (p.12) - Make proper adjustment (p.12) - Make proper adjustment (p. 12) - Make proper adjustment (p. 13) - Clean tabletop
Saw blade scores lumber, finish cut is not smooth	<ul style="list-style-type: none"> - Saw blade is heeling - Column too loose in base - Too much play between arm and column - Rollerhead loose in arm - Yoke too loose when clamped to rollerhead - Bent or dull blade - Not feeding saw properly - Using improper blade 	<ul style="list-style-type: none"> - Make heel adjustment (p. 14) - Make proper adjustment (p.12) - Make proper adjustment (p.12) - Make proper adjustment (p. 12) - Make proper adjustment p. 13) - Replace blade - Draw blade across lumber with slow steady pull - Change blade.

PROBLEM	POSSIBLE CAUSE	SOLUTION
Saw blade or dado blades tend to push lumber to one side when cross cutting	<ul style="list-style-type: none"> - Saw blade is heeling - Column too loose in base - Too much play between arm and column - Rollerhead too loose in arm - Yoke too loose when clamped to rollerhead - Fence not straight - Dull blade or cutters 	<ul style="list-style-type: none"> - Make heel adjustment (p. 14) - Make proper adjustment (p. 12) - Make proper adjustment (p.12) - Make proper adjustment (p. 12) - Make proper adjustment (p. 13) - Replace fence - Replace or sharpen
Cut depth varies from one end of stock to the other	<ul style="list-style-type: none"> - Tabletop not parallel with arm - Column too loose in base - Too much play between arm and column 	<ul style="list-style-type: none"> - Adjust tabletop to arm (p. 13) - Make proper adjustment (p. 12) - Make proper adjustment (p. 12)
45° bevel cut not accurate	<ul style="list-style-type: none"> - Saw blade not perpendicular to tabletop - Column too loose in base - Too much play between arm and column - Rollerhead too loose in arm - Yoke too loose when clamped to rollerhead - Bevel clamp handle loose - Tabletop not parallel to arm 	<ul style="list-style-type: none"> - Make proper adjustment (p. 14) - Make proper adjustment (p. 12) - Make proper adjustment (p. 12) - Make proper adjustment (p. 12) - Make proper adjustment (p. 13) - Make proper adjustment (p.14) - Make proper adjustment (p. 13)
Saw tends to advance over lumber too fast	<ul style="list-style-type: none"> - Rollerhead bearings out of adjustment - Dull blade - Not feeding saw properly 	<ul style="list-style-type: none"> - Adjust bearings (p. 12) - Replace or sharpen blade - Draw blade across lumber with a slow steady pull
Saw does not move smoothly in arm tracks	<ul style="list-style-type: none"> - Dirty tracks - Bad bearing 	<ul style="list-style-type: none"> - Clean tracks - Replace bearing
Miter scale not accurate at various miter angles	<ul style="list-style-type: none"> - Scale pointer not properly adjusted 	<ul style="list-style-type: none"> - Adjust scale pointer (p. 16)
Elevating handle slips when elevating or lowering the saw	<ul style="list-style-type: none"> - Base not adjusted properly 	<ul style="list-style-type: none"> - Adjust base to column (p.12)
Clamping force not sufficient at miter angles other than 45°	<ul style="list-style-type: none"> - Arm clamp out of adjustment 	<ul style="list-style-type: none"> - Adjust arm clamp (p.12)
Clamping force not sufficient at bevel angles other than 45°	<ul style="list-style-type: none"> - Bevel clamp handle too loose 	<ul style="list-style-type: none"> - Adjust bevel clamp (p. 14)

ELECTRICAL TROUBLE-SHOOTING GUIDE

CAUTION—HIGH VOLTAGES ARE DANGEROUS—BE SURE POWER IS OFF AND LOCKED OUT WHEN INSPECTING OR REPAIRING MOTOR OR CONTROLS

TROUBLE	POSSIBLE CAUSE	SUGGESTED REMEDY
Saw motor will neither start nor hum	Power line not connected to cable.	Correct power wiring. See wiring diagram inside magnetic starter box.
	Thermal overload relays may have tripped.	Allow time for overload relays to cool.
	Faulty (brown) line fuse, line circuit breaker tripped.	Check for presence of proper voltage at motor.
	Defective control transformer.	Check circuit with continuity meter. Ensure power is off.
	Start and stop switches at end of arm may be defective.	
	Faulty starter.	
Saw motor hums but will not start (Shut off power immediately)	Open circuit in a thermal relay heater.	Remove heaters. If defective, heater may be completely burned up. Install new heater if required.
	Open circuit in motor cable or cable lugs.	Use a continuity meter and check each wire between control unit and motor. Check lug connections.
	Wiring error.	Check connections in starter box and conduit box, refer to motor and starter connection diagrams.
	Mechanical binding—shaft should turn freely by hand.	Tap end of shaft with mallet to seat bearings in end bells. Check bearings and bell etc. Replace as needed.
	Low voltage—voltage should be measured at the motor while it is starting and blade attached. Voltage should not drop lower than 185 volts for 208, 220 and 230 volt systems.	Check for loose or high resistance connections— make sure lines are of ample capacity and other equipment is not pulling down the voltage.
	Burned out stator	If motor smells or has been smoking each phase winding should be checked with a test lamp or continuity meter.
	Bad capacitor (single phase only).	Turn off power, remove motor nameplate. Discharge capacitor by short circuiting terminals; remove motor from circuit. Test with ohm meter. Needle should jump when leads are touched to capacitor terminals and fall back to a high resistance as capacitor charges.
	Bad starting relay (single phase only).	If contacts are excessively burned, pitted or welded together the relay must be replaced. Check for open relay coil using continuity meter.
Motor trips overload relay or blows line fuse.	Wrong heater or fuse.	Replace with proper heater, fuse or circuit breaker.
	Excessive currents.	Check for grounds or shorts.
	Low voltage.	Check voltage while starting as outlined above.
	Loose or faulty connection.	Locate and repair.

ACCESSORIES

Manual Chain Feed—Provides full control of saw carriage for heavy production work. Use for heavy sawing, dado cutting and rafter notching. Standard on metal cutting radial arm saws.

40021 Chain feed for 44" arm

40022 Chain feed for 52" arm

Electronic Power Crossfeed—Provides the optimum feed rate for the material to be cut. Assures uniform cuts and maximum utilization of blade for efficient cutting.

40005 Feed rates from 0—40 ft/min. Adjustable crosscut travel. Permanently sealed and enclosed drive motor.

Roller Table Extension— 20" wide and 8' long. Eight rollers, mounting brackets and support legs included.

40030-01 Roller table extension 12" centers

40030-02 Roller table extension 6" centers

Blades—

T1613-00 16" x 100 tooth x 1" bore non-ferrous cutting, Negative hook angle

T2013-00 20" x 120 tooth x 1" bore non ferrous cutting, Negative hook angle

T1614-00 16" x 300 tooth x 1" bore ferrous cutting— high speed steel friction cut

T2012-00 20" x 300 tooth x 1" bore ferrous cutting — high speed steel friction cut.

PREVENTIVE MAINTENANCE

Original Radial Arm Saws are designed to provide you with precision cutting with a minimal amount of maintenance. The frequency of the maintenance depends on the amount of use and the desired cutting quality.

Always disconnect and lockout power supply before performing maintenance.

After every 10 –20 hours of use the column should be wiped down with a clean dry rag. Wipe the tracks of the arm with a clean rag and either denatured alcohol or paint thinner. Move the carriage back and forth several times and clean it again. DO NOT lubricate the arm tracks; doing so may cause excessive arm wear due to dust attracting to the arm tracks. Keep the tracks clean and dry; periodically wipe or vacuum sawdust from all exposed surfaces. Check for loose or broken parts and replace if necessary with genuine Original Saw Parts. Check the blade to see if it is sharp and free of wobble.

Adjustment and alignment of saw is necessary only when cutting results in unacceptable accuracy.

After many years of use your saw may need replacement parts. If any of the following wears out all others listed should be checked also.

Rollerhead bearings: Check for free, smooth rotation. Do not attempt to lubricate.

Arm Tracks: If the saw is used primarily for short cut-offs, the tracks may wear making it difficult to adjust the rollerhead bearing for full length arm travel. Arms can generally be remachined—contact Original Saw for pricing and shipping instructions.

Motor bearings: Check for free, smooth rotation. Do not attempt to lubricate.

Elevating mechanism: Remove, clean and lubricate with with type EP grease. Examine threads in the nut for wear.

Industrial Use Warranty Information

Your new Original Radial Arm Saw is precision manufactured under strict quality standards. In the unlikely event there is trouble with your machine, the Original Saw Company warrants the machine for the period of one year from the date of purchase. The warranty covers defects in materials and workmanship. We will cover the cost of the defective part and ground shipping. If a replacement part is sent under warranty the defective part must be returned to Original Saw Company or you will be charged for the replacement. When the part is returned it may be repaired or replaced at our discretion. The part must be shipped prepaid to: The Original Saw Company, Attn. Warranty Replacement Counter, 465 Third Avenue SE, Britt, Iowa 50423. The part must also be accompanied by a return goods authorization number. This number can be obtained by calling customer service at 800-733-4063.

IMPORTANT

IMPORTANT

IMPORTANT

To assure product reliability, repairs, maintenance and adjustments should be performed by Authorized Service Centers, always using genuine replacement parts.



**465 Third Ave SE
Britt, IA 50423**

**PH 800/733-4063 641/843-3868
FX 641/843-3869**

e-mail customerservice@originalsaw.com

For parts or service please contact the manufacturer for the dealer nearest you.