

SAC2411

Legend

- 1 Return Air
- 2 Control Pad
- 3 Cold Air Supply
- 4 Condenser Air Inlet
- 5 Condenser Air Outlet
- 6 Power Cord
- 7 Condensate Nipple
- 8 Condensate Alarm Jack
- 9 Access Door

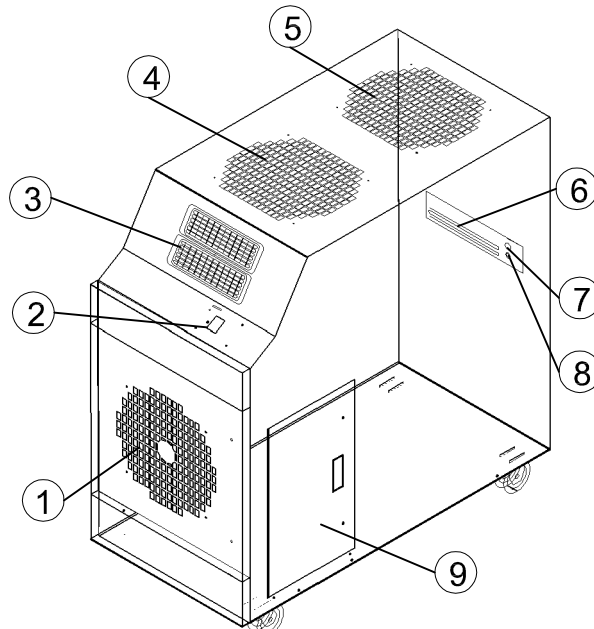

Isometric View

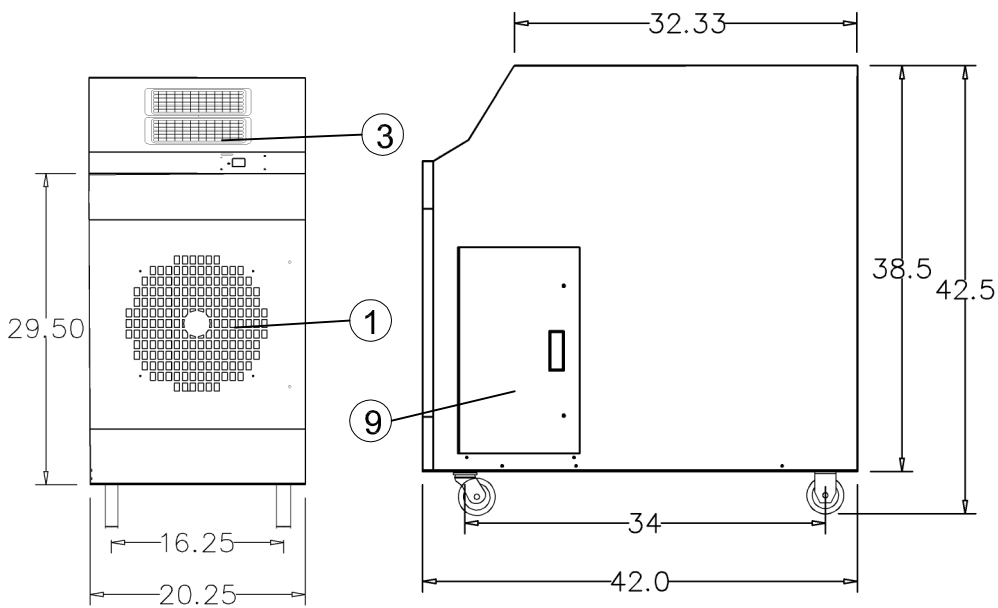

Front View

Right View



ETL LISTED CONFORMS TO ANSI/UL
1995 CERTIFIED TO CAN/CSAA22.2 NO.235



1-800-KWIKOOL

Model SAC2411 - 2 Ton

| COOLING CAPACITY | | |
|--------------------|-------------------------------------|----------------------------|
| | BTU/hr @ 95 F at 60%RH | 23,500 (2 TONS) |
| COMPRESSOR DATA | | |
| | Compressor Type | HERMETIC RECIP. |
| | Operating Temperatures | 60-110 F .50%RH |
| | Non-CFC Refrigerant Charge (Lbs.) | 407C |
| FAN DATA | | |
| EVAPORATOR | | |
| | Fan Type (Centrifugal) | DIRECT DRIVE |
| | Air Flow (CFM) | 725/Single Speed |
| | Supply Air Chute Data | ADJUSTABLE VENT |
| | Supply Air Chute Kit (Optional) | 2 6" Dia. x 15" Length |
| | Motor HP | 1/5 |
| CONDENSER | | |
| | I/O Intergral Condenser - In/Out | BALANCED AIR FLOW |
| | Fan Type (Centrifugal) | DIRECT DRIVE |
| | Air Flow (CFM) | 1050 |
| | Condenser Hose Data (Optional) | 2-14" Dia x 8' Length |
| | Condenser Hose Max. Length | 25' |
| | Motor HP | 1/3 |
| ELECTRICAL DATA | | |
| | Power Supply (Volts) | 115/Single Phase |
| | Current Consumption (Amps) | 17 |
| | Power Consumption (KW) | 2 |
| | Maximum Circuit Breaker (Amps) | 20 |
| | Minimum Circuit Ampacity (Amps) | 20.1 |
| | Min/Max Voltage | 105-125 |
| | Power Cord Gauge/Length | 12AWG/6 |
| | Plug Configuration | NEMA 5-20 |
| DIMENSIONAL DATA | | |
| Unitary Models | Width x Depth x Height (Inches) | 20.25X42X42.5 |
| | Weight (Lbs.) | 288 |
| | Shipping Weight (Lbs.) | 373 |
| | Ceiling Kit - CK-24 Weight | 47 |
| | Total Shipping Weight/w Ceiling Kit | 435 |
| SAFETY DEVICE DATA | | |
| | Compressor Overload | INTERNAL |
| | Fan Motor Overload | AUTOMATIC INTERNAL |
| | Evaporator Freeze-up | HOT GAS BYPASS |
| | High Pressure Switch | MANUAL |
| | Low Pressure Switch | AUTOMATIC |
| | Compressor Short Cycle | YES |
| | Automatic Restart | YES |
| | Thermostat | MICROPROCESSOR/ DIGITAL |
| | Condensate Pump w 20' Head Pres. | YES |
| | Condensate Pump Overflow | YES |
| | Condensate Tank Overflow | YES |



1-800-KWIKOOL