

**Model 571M1 with Standard Fixed Boom**

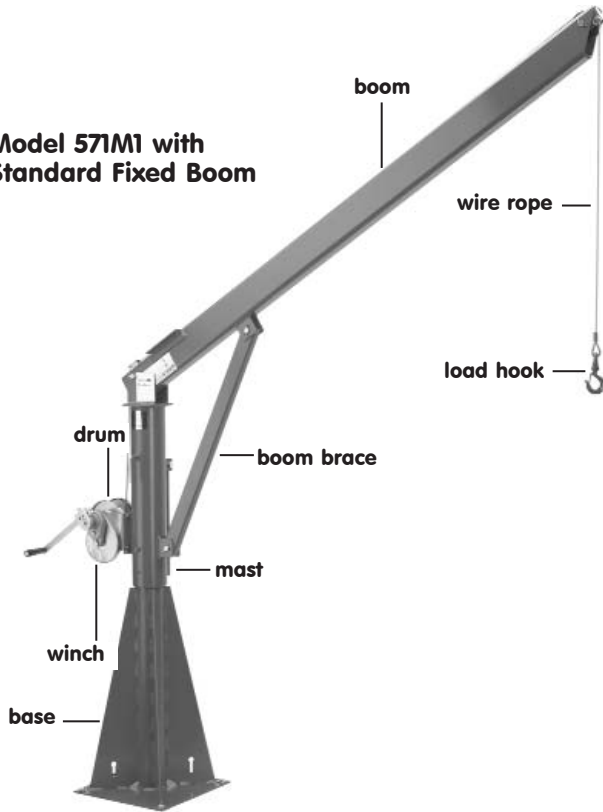

**Model 571M2 with Adjustable Boom Option**

## Series 571 and 572 Fre Rol Davit Cranes

Hand or Power Winch Operation  
Up to 2200 lb capacity

- **Hand Winch Operated Models** include spur gear or worm gear hand winch with brake for load control. Model 571M2 can be drill driven, 400 rpm max.
- **Power Winch Operated Models** include 115 volt 1 phase AC electric winch with pendant control and brake. Other power options available, please contact factory.
- **Fixed Boom** – Boom Position C
- **Adjustable Boom Option** – adjusts between Boom Position A and D – with hand operated ratchet style screw-jack, used to adjust height and reach.
- **Mast and Boom Rotate** on tapered roller bearings for smooth 360° load movement. Mast locks in one of four positions with hand tightened lock bolt. Handle on the mast makes rotation easy.
- **Gusset Style Base** for permanent installation and stability under load.
- **Epoxy Finish** available for improved protection against corrosion.
- **Wire Rope Assemblies** sold separately. See tables on following pages.
- **Two-year Limited Warranty**

### Series 571 and 572 – Crane Configurations, Bases, and Options – Section 4 Pricing

model	description	approx. ship wt.
571M1	up to 1500 lb – with M4312PB-K spur gear hand winch	425 lb
571M2	up to 1500 lb – with 4WM2V-K worm gear hand winch	450 lb
571E2	up to 1500 lb – with 4WP2-K electric winch – 115 VAC, 1 phase, 6 ft pendant control	475 lb
571E4	up to 1500 lb – with 4777-K electric winch – 115 VAC, 1 phase, 6 ft pendant control	489 lb
572M1	up to 2200 lb – with M452B-K spur gear hand winch	720 lb
572E3	up to 2000 lb – with 4771-K electric winch – 115 VAC, 1 phase, 6 ft pendant control	750 lb
572E5	up to 2200 lb – with 4WS3M6-K electric winch – 115 VAC, 1 phase, 6 ft pendant control <b>(other configurations available, please contact factory)</b>	750 lb
SJ1	ratchet style screw-jack for Series 571 (replaces standard boom brace)	37 lb
SJ2	ratchet style screw-jack for Series 572 (replaces standard boom brace)	97 lb

Please contact factory or nearest Thern Distributor for firm fixed price and delivery.

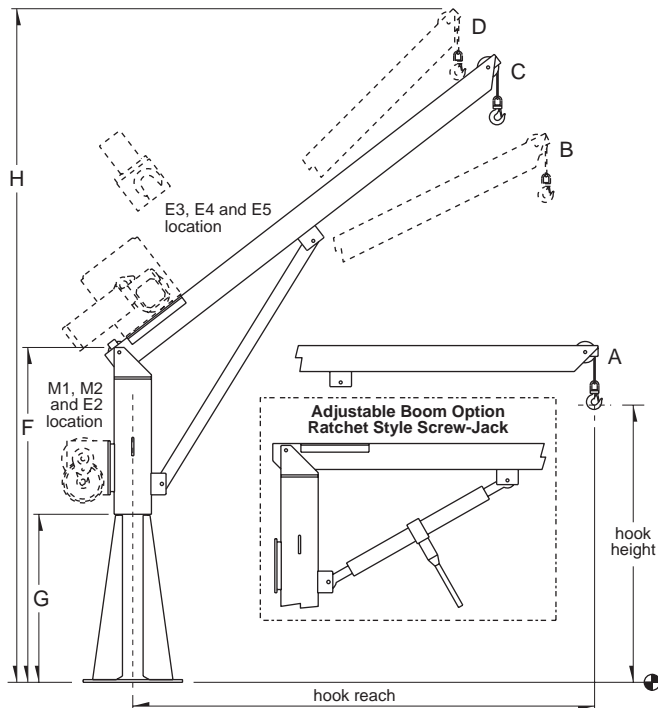

**Series 571 and 572 Crane Dimensions**

	Series 571	Series 572
F	67.19 in	77.41 in
G	32.88 in	38.62 in
H	131.19 in	155.75 in
Q	16.00 in	20.00 in
R	18.00 in	23.00 in
S (hole dia.)	.56 in	.81 in

Dimensions are for reference only and subject to change without notice.

**Important:**

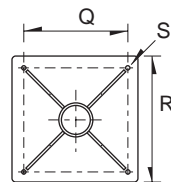
Load rating will vary with wire rope length and boom position. Please see Performance Characteristics table on the following page.

**Important:**

It is the owner's or operator's responsibility to determine the suitability of the equipment to its intended use. Study all applicable codes, manuals, and regulations. Be sure to read the Owner's Manual supplied with the equipment before operating it.

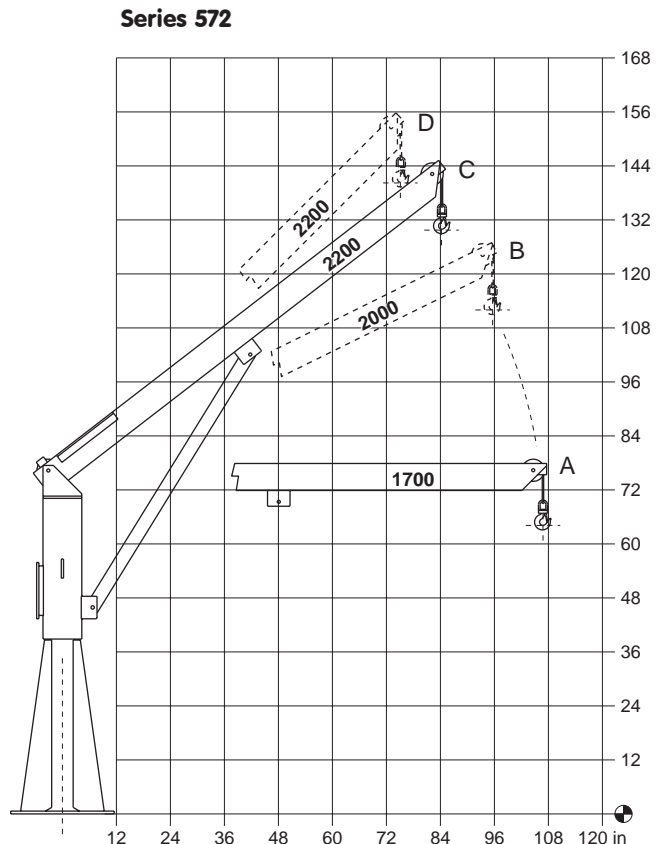
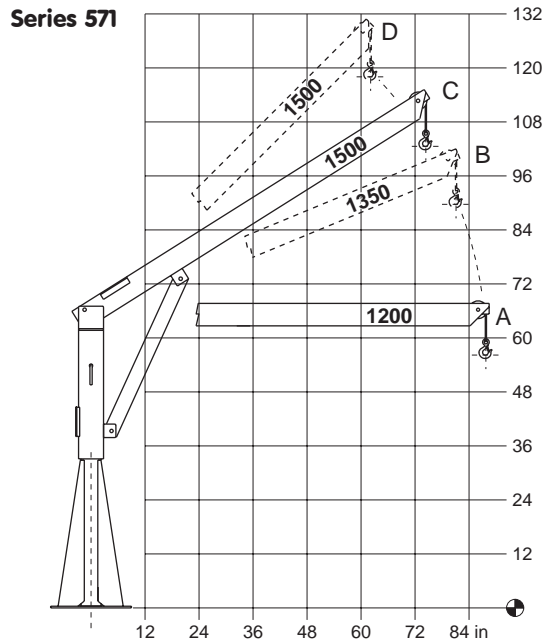
**Series 571 and 572 – Height and Reach**

series	boom position	hook reach	hook height
571	A	87.88 in	56.00 in
	B	81.25 in	90.00 in
	C (fixed)	74.56 in	102.00 in
	D	62.25 in	118.00 in
572	A	106.75 in	64.00 in
	B	95.50 in	112.00 in
	C (fixed)	84.25 in	130.00 in
	D	75.00 in	140.00 in

Dimensions are for reference only and subject to change without notice.

**Important:**

Base installation is purchaser's responsibility. Thern recommends consulting a civil engineer or other qualified professional.

**WIRE ROPE ASSEMBLIES – sold separately**

- Galvanized or Stainless Steel wire rope assemblies.

**Wire Rope Assemblies – Section 9 Pricing**

model number	wire rope diameter and length	approx. ship weight
galvanized aircraft cable with swivel hook and swaged ball fitting		
WA25-28NS	1/4 in x 28 ft	5 lb
WA25-36NS	1/4 in x 36 ft	6 lb
WA25-45NS	1/4 in x 45 ft	7 lb
WA25-60NS	1/4 in x 60 ft	9 lb
WA25-75NS	1/4 in x 75 ft	10 lb

304 stainless steel wire rope with SS eye hook and swaged ball fitting - swivel hook also available please contact factory		
WS25-28NE	1/4 in x 28 ft	5 lb
WS25-36NE	1/4 in x 36 ft	6 lb
WS25-45NE	1/4 in x 45 ft	7 lb
WS25-60NE	1/4 in x 60 ft	8 lb
WS25-75NE	1/4 in x 75 ft	10 lb

galvanized aircraft cable with swivel hook and unfinished end		
WA31-28DS	5/16 in x 28 ft	7 lb
WA31-36DS	5/16 in x 36 ft	9 lb
WA31-45DS	5/16 in x 45 ft	10 lb
WA31-60DS	5/16 in x 60 ft	13 lb
WA31-75DS	5/16 in x 75 ft	15 lb

304 stainless steel wire rope with SS eye hook and unfinished end - swivel hook also available please contact factory		
WS31-28DE	5/16 in x 28 ft	7 lb
WS31-36DE	5/16 in x 36 ft	9 lb
WS31-45DE	5/16 in x 45 ft	11 lb
WS31-60DE	5/16 in x 60 ft	14 lb
WS31-75DE	5/16 in x 75 ft	17 lb

Please contact factory or nearest Thern Distributor for firm fixed price and delivery.

**Important:**

It is the owner's or operator's responsibility to determine the suitability of the equipment to its intended use. Study all applicable codes, manuals, and regulations. Be sure to read the Owner's Manual supplied with the equipment before operating it.

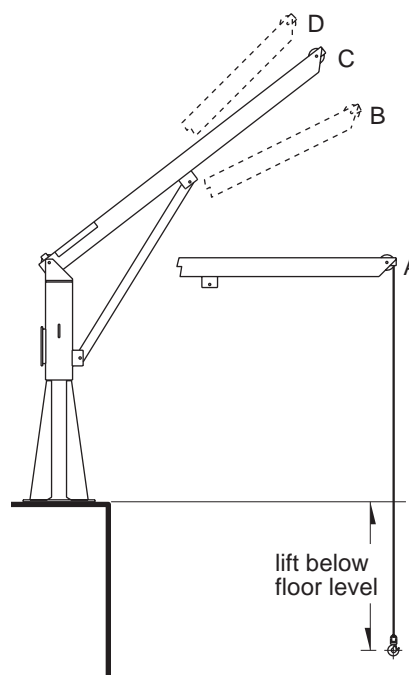
**Series 571 Performance Characteristics**

wire rope dia.	wire rope length	load rating for 571M1, 571M2 and 571E2				load rating for 571E4 <sup>2</sup>				lift below floor level (min – max) <sup>1</sup>
		position A	position B	position C	position D	position A	position B	position C	position D	
1/4 in	28 ft	1200 lb	1350 lb	1500 lb	1500 lb	1200 lb	1350 lb	1500 lb	1500 lb	4 – 9 ft
1/4 in	36 ft	1200 lb	1350 lb	1500 lb	1500 lb	1200 lb	1350 lb	1500 lb	1500 lb	12 – 17 ft
1/4 in	45 ft	1200 lb	1350 lb	1400 lb	1400 lb	1200 lb	1350 lb	1500 lb	1500 lb	21 – 26 ft
1/4 in	60 ft	1200 lb	1300 lb	1300 lb	1300 lb	1200 lb	1350 lb	1400 lb	1400 lb	36 – 41 ft
1/4 in	75 ft	–	–	–	–	1200 lb	1300 lb	1300 lb	1300 lb	51 – 56 ft

<sup>1</sup> Lift below floor level varies depending on boom position and winch configuration. For longer lifts contact factory.

<sup>2</sup> Add 2 ft to lift below floor level for Model 571E4.

**Series 572 Performance Characteristics**

wire rope dia.	wire rope length	load rating for 572M1 and 572E5 <sup>2</sup>				load rating for 572E3 <sup>2</sup>				lift below floor level (min – max) <sup>1</sup>
		position A	position B	position C	position D	position A	position B	position C	position D	
1/4 in	28 ft	1700 lb	2000 lb	2200 lb	2200 lb	1700 lb	1700 lb	1700 lb	1700 lb	-1 – 5 ft
1/4 in	36 ft	1700 lb	2000 lb	2200 lb	2200 lb	1700 lb	1700 lb	1700 lb	1700 lb	7 – 13 ft
1/4 in	45 ft	1700 lb	2000 lb	2200 lb	2200 lb	1500 lb	1500 lb	1500 lb	1500 lb	16 – 22 ft
1/4 in	60 ft	1700 lb	2000 lb	2200 lb	2200 lb	1300 lb	1300 lb	1300 lb	1300 lb	31 – 37 ft
1/4 in	75 ft	1700 lb	2000 lb	2200 lb	2200 lb	1300 lb	1300 lb	1300 lb	1300 lb	46 – 52 ft

<sup>1</sup> Lift below floor level varies depending on boom position and winch configuration. For longer lifts contact factory.

<sup>2</sup> Add 3 ft to lift below floor level for Model 572E3 and 572E5.