

# OPERATION AND PARTS MANUAL



## **MODEL AR-13D** **RIDE-ON TANDEM DRUM ROLLER** **SERIES DRIVE SYSTEM** **(DIESEL ENGINE)**

Revision #0 (07/13/07)

To find the latest revision of this  
publication, visit our website at:  
[www.multiquip.com](http://www.multiquip.com)



**THIS MANUAL MUST ACCOMPANY THE EQUIPMENT AT ALL TIMES.**



**CALIFORNIA — Proposition 65 Warning**

Engine exhaust and some of its constituents are known to the State of California to cause cancer, birth defects and other reproductive harm.



# AR-13D RIDE-ON ROLLER — TABLE OF CONTENTS

## MULTIQUIP AR-13D RIDE-ON TANDEM DRUM ROLLER

Proposition 65 Warning .....	2
Table Of Contents .....	4
Parts Ordering Procedures .....	5
Safety Message Alert Symbols .....	6-7
Rules For Safe Operation .....	8-10
Operation and Safety Decals .....	11-12
Specifications (Roller) .....	13
Specifications (Engine) .....	14
Dimensions .....	15
General Information .....	16-17
Roller Components .....	18-20
Engine Components .....	21
Inspection .....	22-24
Initial Start-Up .....	25
Operation .....	26
Maintenance .....	27-36
Preparation For Long-Term Storage .....	37
Manifold Test Ports .....	38
Hydraulic System Diagram .....	39
Electric Wiring Diagram .....	40
Hydraulic Hose Connection .....	42-43
Troubleshooting (Roller) .....	44
Troubleshooting (Engine) .....	45-46

## COMPONENT DRAWINGS

Explanation Of Code In Remarks Column .....	48
Suggested Spare Parts .....	49
Name Plate and Decals .....	50-51
Front Drum Assembly .....	52-53
Exciter Assembly .....	54-55
Rear Drum and Chassis Assembly .....	56-57
Covers and Frame Articulation Lock Assy. ....	58-59
Hood and Rear Panel Assembly .....	60-61
Steering Column and Hydraulic Artic. Assy. ....	62-63
Articulation Arm Assembly .....	64-65
Hydraulic Drive Pump Assembly .....	66-67
Manifold and Hydraulic Oil Filter Assembly .....	68-69
Fuel Tank and Oil Drain Hose Assembly .....	70-71
Water Tank Assembly .....	72-73
Engine Mounting Assembly .....	74-75
Muffler Assembly .....	76-77
Air Cleaner Assembly .....	78-79
Radiator Assembly .....	80-81
Throttle Assy. ....	82-83
Brake Control Assy. ....	84-85
Battery Assy. ....	86-87
Scraper Assy. ....	88-89
Terms and Conditions of Sale .....	90

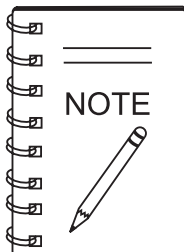

***Specification and part number  
are subject to change without  
notice.***

# PARTS ORDERING PROCEDURES

www.multiquip.com

## Ordering parts has never been easier! Choose from three easy options:

Effective:  
January 1<sup>st</sup>, 2006



### Order via Internet (Dealers Only):

Order parts on-line using Multiquip's SmartEquip website!

- View Parts Diagrams
- Order Parts
- Print Specification Information



If you have an MQ Account, to obtain a Username and Password, E-mail us at: [parts@multiquip.com](mailto:parts@multiquip.com).

To obtain an MQ Account, contact your District Sales Manager for more information.

Goto [www.multiquip.com](http://www.multiquip.com) and click on **Order Parts** to log in and save!

Use the **internet** and qualify for a **5% Discount** on *Standard orders* for all orders which include complete part numbers.\*

Note: Discounts Are Subject To Change



### Order via Fax (Dealers Only):

All customers are welcome to order parts via Fax.

**Domestic (US) Customers dial:**  
1-800-6-PARTS-7 (800-672-7877)

**Fax** your order in and qualify for a **2% Discount** on *Standard orders* for all orders which include complete part numbers.\*

Note: Discounts Are Subject To Change



**Order via Phone: Domestic (US) Dealers Call:**  
1-800-427-1244

### Non-Dealer Customers:

Contact your local Multiquip Dealer for parts or call 800-427-1244 for help in locating a dealer near you.



**International Customers** should contact their local Multiquip Representatives for Parts Ordering information.

## When ordering parts, please supply:

- |   |  |
|---|--|
| <input type="checkbox"/> Dealer Account Number                                | <input type="checkbox"/> Specify Preferred Method of Shipment:                         |
| <input type="checkbox"/> Dealer Name and Address                              | <input checked="" type="checkbox"/> UPS/Fed Ex <input checked="" type="checkbox"/> DHL |
| <input type="checkbox"/> Shipping Address (if different than billing address) | <input type="checkbox"/> Priority One <input checked="" type="checkbox"/> Truck        |
| <input type="checkbox"/> Return Fax Number                                    | <input type="checkbox"/> Ground  |
| <input type="checkbox"/> Applicable Model Number                              | <input type="checkbox"/> Next Day  |
| <input type="checkbox"/> Quantity, Part Number and Description of Each Part   | <input type="checkbox"/> Second/Third Day  |

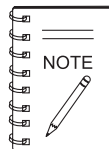

All orders are treated as *Standard Orders* and will ship the same day if received prior to 3PM PST.

WE ACCEPT ALL MAJOR CREDIT CARDS!



# AR-13D RIDE-ON ROLLER — SAFETY MESSAGE ALERT SYMBOLS

## FOR YOUR SAFETY AND THE SAFETY OF OTHERS!

Safety precautions should be followed at all times when operating this equipment. Failure to read and understand the Safety Messages and Operating Instructions could result in injury to yourself and others.



This Owner's Manual has been developed to provide complete instructions for the safe and efficient operation of the Multiquip Model AR-13D Ride-on Tandem Drum Roller. Refer to the engine manufacturers instructions for data relative to its safe operation.

**Before using this roller, ensure that the operating individual has read and understands all instructions in this manual.**

## SAFETY MESSAGE ALERT SYMBOLS

The three (3) Safety Messages shown below will inform you about potential hazards that could injure you or others. The Safety Messages specifically address the level of exposure to the operator, and are preceded by one of three words: **DANGER**, **WARNING**, or **CAUTION**.

### **DANGER**

You **WILL** be **KILLED** or **SERIOUSLY** injured if you do not follow directions.

### **WARNING**

You **COULD** be **KILLED** or **SERIOUSLY** injured if you do not follow directions.

### **CAUTION**

You **CAN** be injured if you do not follow directions

## HAZARD SYMBOLS

Potential hazards associated with operation of the pump will be referenced with Hazard Symbols which appear throughout this manual, and will be referenced in conjunction with Safety Message Alert Symbols. Some examples are listed below:

### **WARNING - LETHAL EXHAUST GASES**



Gasoline engine exhaust gases contain poisonous carbon monoxide. This gas is colorless and odorless, and can cause death if inhaled. **NEVER** operate this equipment in a confined area or enclosed structure that does not provide ample free flow air.

### **WARNING - EXPLOSIVE FUEL**



**Gasoline** is extremely flammable, and its vapors can cause an explosion if ignited. **DO NOT** start the engine near spilled fuel or combustible fluids. **DO NOT** fill the fuel tank while the engine is running or hot. **DO NOT** overfill tank, since spilled fuel could ignite if it comes into contact with hot engine parts or sparks from the ignition system. Store fuel in approved containers, in well-ventilated areas and away from sparks and flames. **NEVER** use fuel as a cleaning agent.

### **WARNING - BURN HAZARDS**



Engine components can generate extreme heat. To prevent burns, **DO NOT** touch these areas while the engine is running or immediately after operations. **NEVER** operate the engine with heat shields or heat guards removed.

# AR-13D RIDE-ON ROLLER — SAFETY MESSAGE ALERT SYMBOLS

## WARNING - ROTATING PARTS



**NEVER** operate equipment with covers, or guards removed. Keep **fingers, hands, hair** and clothing away from all moving parts to prevent injury.

## CAUTION - RESPIRATORY HAZARDS



**ALWAYS** wear approved **respiratory** protection.

## CAUTION - ACCIDENTAL STARTING



**ALWAYS** place the **Engine ON/OFF** switch in the **OFF** position and remove the ignition key when the pump is not in use.

## CAUTION - SIGHT AND HEARING HAZARDS

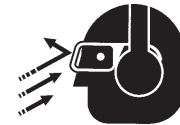

**ALWAYS** wear approved **eye** and **hearing** protection.

## CAUTION - OVER-SPEED CONDITIONS



**NEVER** tamper with the factory settings of the engine governor or settings. Personal injury and damage to the engine or equipment can result if operating in speed ranges above maximum allowable.

## CAUTION - EQUIPMENT DAMAGE MESSAGES

Other important messages are provided throughout this manual to help prevent damage to your concrete pump, other property, or the surrounding environment.



This Ride-on Tandem Drum Roller, other property, or the surrounding environment could be damaged if you do not follow instructions.

# AR-13D RIDE-ON ROLLER — RULES FOR SAFE OPERATION

## DANGER - Read This Manual!

Failure to follow instructions in this manual may lead to serious injury or even **DEATH!** This equipment is to be operated by trained and qualified personnel only! This equipment is for industrial use only.

The following safety guidelines should always be used when operating the AR-13D Ride-on Tandem Drum Roller:

### GENERAL SAFETY

- **DO NOT** operate or service this equipment before reading this entire manual.
- This equipment should not be operated by persons under 18 years of age.
- **NEVER** operate this equipment without proper protective clothing, shatterproof glasses, steel-toed boots and other protective devices required by the job.
- **NEVER** operate this equipment when not feeling well due to fatigue, illness or taking medicine.
- **NEVER** operate this equipment under the influence of drugs or alcohol.
- Whenever necessary, replace nameplate, operation and safety decals when they become difficult read.
- **ALWAYS** check the machine for loosened threads or bolts before starting.
- **ALWAYS** wear proper respiratory (mask) hearing and eye protection equipment when operating the roller.



- **NEVER** operate this equipment when not feeling well due to fatigue, illness or taking medicine.
- **NEVER** operate this equipment under the influence of **drugs** or **alcohol**.



- **NEVER** touch the hot exhaust manifold, muffler or cylinder. Allow these parts to cool before servicing engine or pump.

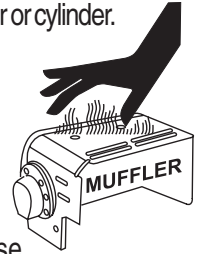

- **High Temperatures** – Allow the engine to cool before adding fuel or performing service and maintenance functions. Contact with *hot* components can cause serious burns.

- The engine of this roller requires an adequate free flow of cooling air. Never operate the roller in any enclosed or narrow area where free flow of the air is restricted. If the air flow is restricted it will cause serious damage to the roller or engine and may cause injury to people and property. Remember the roller's engine gives off **DEADLY** gases.

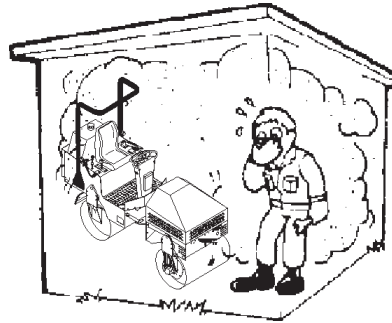

- **ALWAYS** refuel in a well-ventilated area, away from sparks and open flames.
- **ALWAYS** use extreme caution when working with **flammable** liquids. When refueling, **stop the engine** and allow it to cool. **DO NOT** smoke around or near the machine. Fire or explosion could result from fuel vapors, or if fuel is spilled on a hot engine.
- **NEVER** operate the Ride-on Tandem Drum Roller in an explosive atmosphere or near combustible materials. An explosion or fire could result causing severe *bodily harm or even death*.
- Topping-off to filler port is dangerous, as it tends to spill fuel.
- Refer to the **Engine Owner's Manual** for engine technical questions or information.
- **NEVER** use accessories or attachments, which are not recommended by Multiquip for this equipment. Damage to the equipment and/or injury to user may result.
- Manufacturer does not assume responsibility for any accident due to equipment modifications.

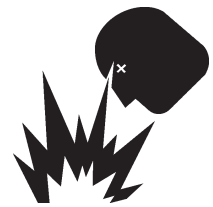

# AR-13D RIDE-ON ROLLER — RULES FOR SAFE OPERATION

- **NEVER** Run engine without air cleaner. Severe engine damage may occur.
- **ALWAYS** read, understand, and follow procedures in Operator's Manual before attempting to operate equipment.
- **ALWAYS** be sure the operator is familiar with proper safety precautions and operations techniques before using roller.
- **ALWAYS** store equipment properly when it is not being used. Equipment should be stored in a clean, dry location out of the reach of children.
- **DO NOT** operate this roller with hydrostatic oil temperature higher than 180 degrees fahrenheit.
- **NEVER** leave the roller unattended, turn off engine and place parking brake lever in upright position.
- **CAUTION** must always be observed while servicing this roller. Rotating parts can cause injury if contacted.
- **DO NOT** leave roller with engine running.
- If the roller must be stopped on an incline (grade), remove the ignition key and place chock blocks (not provided) under **the front** and **rear** drums.
- **NEVER** drive the roller on unshored trenches or near steep, unsupported banks. The vibration caused by the roller could cause a cave-in.
- **ALWAYS** use extreme care when operating near obstructions, on slippery surfaces, grades and side slopes.
- **ALWAYS** wear slip resistant safety shoes or boots.
- Unauthorized equipment modifications will void all warranties.
- When working on slopes, avoid **sidehill travel**. Operate up and down travel only. Remember, the danger of sliding on and/or tripping on steep slopes is always present.
- **ALWAYS** wear **seat belts**.
- When malfunctions occur, always remove the ignition key and place a "**DO NOT OPERATE**" sign in the operator's seat.
- If a malfunction occurs with the travel lever mechanism, speed and direction will be impossible to control. Immediately stop the roller and correct the problem.
- If the steering system operates improperly, immediately stop the engine and apply the parking brake.
- In the event of hydraulic hose or line failure, promptly return the travel lever to the "neutral" position, stop the engine and set the parking brake.

## MAINTENANCE SAFETY

- **NEVER** lubricate components or attempt service on a running machine.
- **ALWAYS** allow the machine a proper amount of time to cool before servicing.
- Keep the machinery in proper running condition.
- Fix damage to the machine immediately and always replace broken parts, or missing decals.
- Dispose of hazardous waste properly. Examples of potentially hazardous waste are used motor oil, fuel and fuel filters.
- **DO NOT** use food or plastic containers to dispose of hazardous waste.
- **DO NOT** pour waste, oil or fuel directly onto the ground, down a drain or into any water source.

# AR-13D RIDE-ON ROLLER — RULES FOR SAFE OPERATION

## LOADING AND TRANSPORTING SAFETY

### DANGER - Loading & Unloading the Roller

**DANGER!** ALWAYS load and unload the roller on **Level, Hard Ground, or Pavement**. **Serious injury or death** can result from improper loading, lifting or unloading. Use extreme caution!

- The roller has an operating weight of approximately 3,088 lbs. (1,400 Kg). Use lifting equipment capable of lifting this weight.
- **ALWAYS** check the roller's lifting hooks. Before lifting or transporting the roller, lock the frame with the locking bar that is provided. Make sure the hooks are secure and tight before lifting the machine.
- When driving the roller onto a transporting vehicle or trailer, use ramps or other suitable material of sufficient strength to support the roller.
- Remove mud, oil, ice, snow or any other slippery materials from the ramps and bed of the vehicle to avoid accidents.
- After loading, apply the parking brake.
- Use a chain, binders or other suitable means to firmly secure the roller before transporting.
- Only use the lifting points for the roller that are clearly marked as "**lifting point**".
- **NEVER** apply chains through the articulating section of the roller. The chain could cause damage by scoring the hydraulic steering cylinder.
- **NEVER** stand below roller when it is being lifted.

### DANGER - Transporting Safety

**DO NOT** allow personnel to **stand under** or **near** any suspended machine. **Serious injury or death** may result.

## EMERGENCIES

- **ALWAYS** know the location of the nearest **fire extinguisher**.



- **ALWAYS** know the location of the nearest and **first aid kit**.



- In emergencies **always** know the location of the nearest phone or **keep a phone on the job site**. Also know the phone numbers of the nearest **ambulance, doctor** and **fire department**. This information will be invaluable in the case of an emergency.



# AR-13D RIDE-ON ROLLER — OPERATION AND SAFETY DECALS

## Machine Safety Decals

The AR-13D Ride-on Tandem Drum Roller is equipped with a number of safety decals. These decals are provided for operator safety and maintenance information. The illustration below and on the next page shows these decals as they appear on the machine. Should any of these decals become unreadable, replacements can be obtained from your dealer.

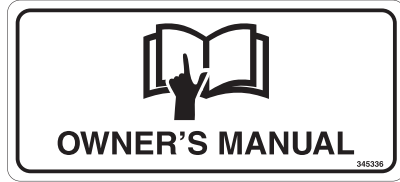

P/N: 34536



P/N: 511735

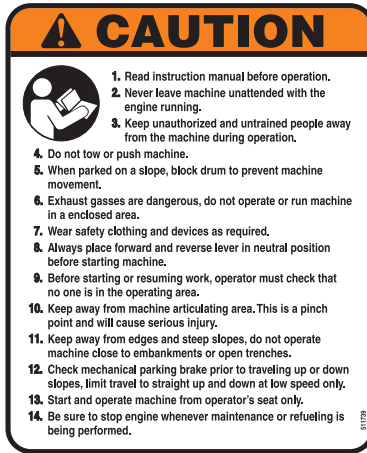

P/N: 511739

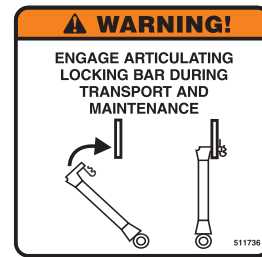

P/N: 511736

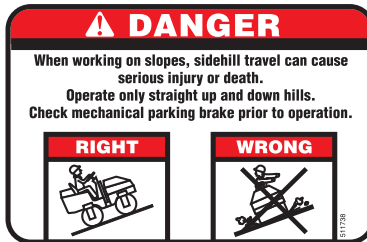

P/N: 511738

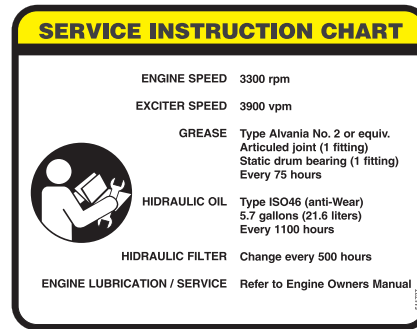

P/N: 511737



P/N: 513740



P/N: 515818



P/N: 513469



P/N: 515815

# AR-13D RIDE-ON ROLLER — OPERATION AND SAFETY DECALS

# MQ MULTIQUIP

P/N: 511740



P/N: 511724



P/N: 511726



P/N: 513688



P/N: 511733



P/N: 511718

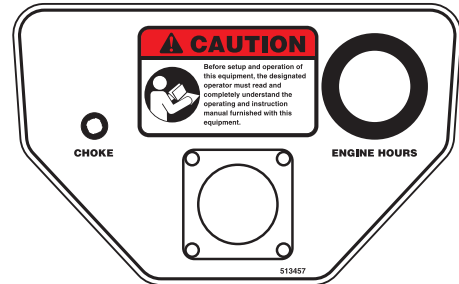

P/N: 513457

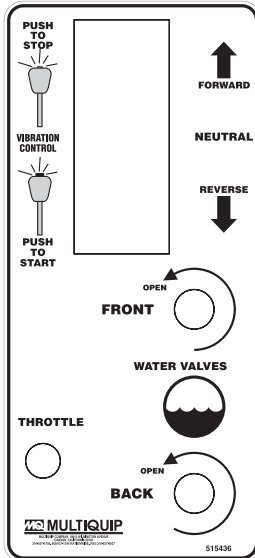

P/N: 515436



P/N: 513393

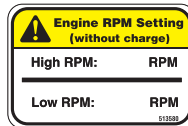

P/N: 513580

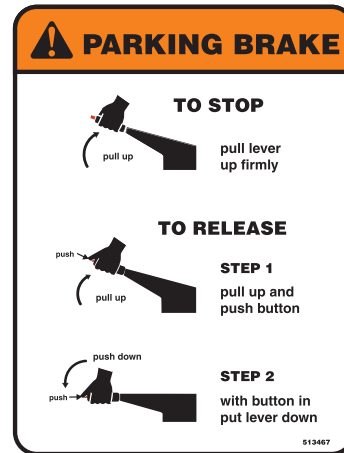

P/N: 513467

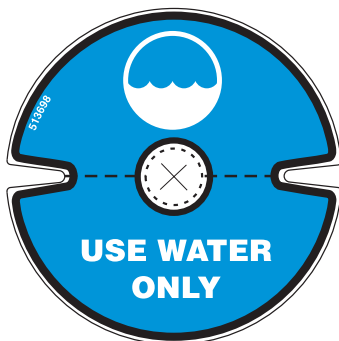

P/N: 513698

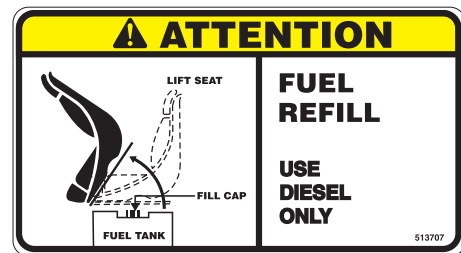

P/N: 516558

# AR-13D RIDE-ON ROLLER — SPECIFICATIONS (ROLLER)

**Table 1. AR-13D Roller Specifications**

Shipping Weight	2,700 lbs. (1,225 Kg.)
Dry Weight	2,556 lbs. (1,160 Kg.)
Operating Weight	3,360 lbs. (1,524 Kg.)
Operating Weight w/ Drum Ballast	3,437 lbs. (1,559 Kg.)
Overall Length	90.5 in. (2,286 mm.)
Overall Width	38.25 in. (972 mm.)
Overall Height-ROPS (up)	87.0 in. (2,210 mm.)
Maximum Rolling Width	35.7 in. (907 mm.)
Turning Radius-Inside	109 in. (2,768 mm.)
Ground Clearance	11.5 in. (292 mm.)
Curb Clearance	7.75 in. L, 19.0 in. R (197 mm., 483 mm.)
Wall Clearance	1.75 in L, 1.25 in. R (45 mm., 32 mm.)
Wheelbase	45 in. (1,143 mm.)
Drum Width	35.7 in. (907mm.)
Drum Diameter	22.6 in. (574 mm.)
Drum Thickness	0.38 in. (10.0 mm.)
Centrifugal Force @ 2,400 - 2,700 rpm	3,100 lbs. (1,406 Kg.)
Vibrations per minute @ 2,400 - 2,700 rpm	4,000 VPM
Dynamic Linear Force per Drum 2,400 - 2,700 rpm	87.5 lbs./in. (39.6 Kg./cm.) (front only)
Oscillating Angle	11 degrees
Hydraulic Oil Tank Capacity	5.7 U.S. Gallons (21.6 Liters)
Cooling System	Air
Fuel	Diesel
Fuel Tank Capacity	9.5 U.S. Gallons (36 Liters)
Water Tank Capacity	40 Gallons (152 Liters)
Battery	12 Volt GroupType U1
Travel Speed -variable	0-4.8 MPH (0-7.7 KPH)
Grade Ability w-w/o Vibration	15 degrees (27%)

## AR-13D RIDE-ON ROLLER — SPECIFICATIONS (ENGINE)

<b>Table 2. Engine Specifications</b>	
<b>Model</b>	<b>Briggs &amp; Stratton DM 850D</b>
Type	Diesel Engine
Number of Cylinders	3
[Bore x Stroke]	2.67 in. x 307 in. (68 mm x 78 mm)
Displacement	51.8 cu. in. (850 cc)
Horsepower HP@ 3600RPM	23.6 gross 21.1 (net intermittent) 18.3 ( net continuous)
Max. Torque Ft./lbs. @ 2400 RPM	40.0/2400 gross 35.0/2400
Dry Weight	185.0 lbs. (84.0 kg.)
Engine Oil without Filter	3.17 qts. (3.0 liters)
Engine Oil with Filter	3.5 qts. (3.3 liters)

# AR-13D RIDE-ON ROLLER — DIMENSIONS

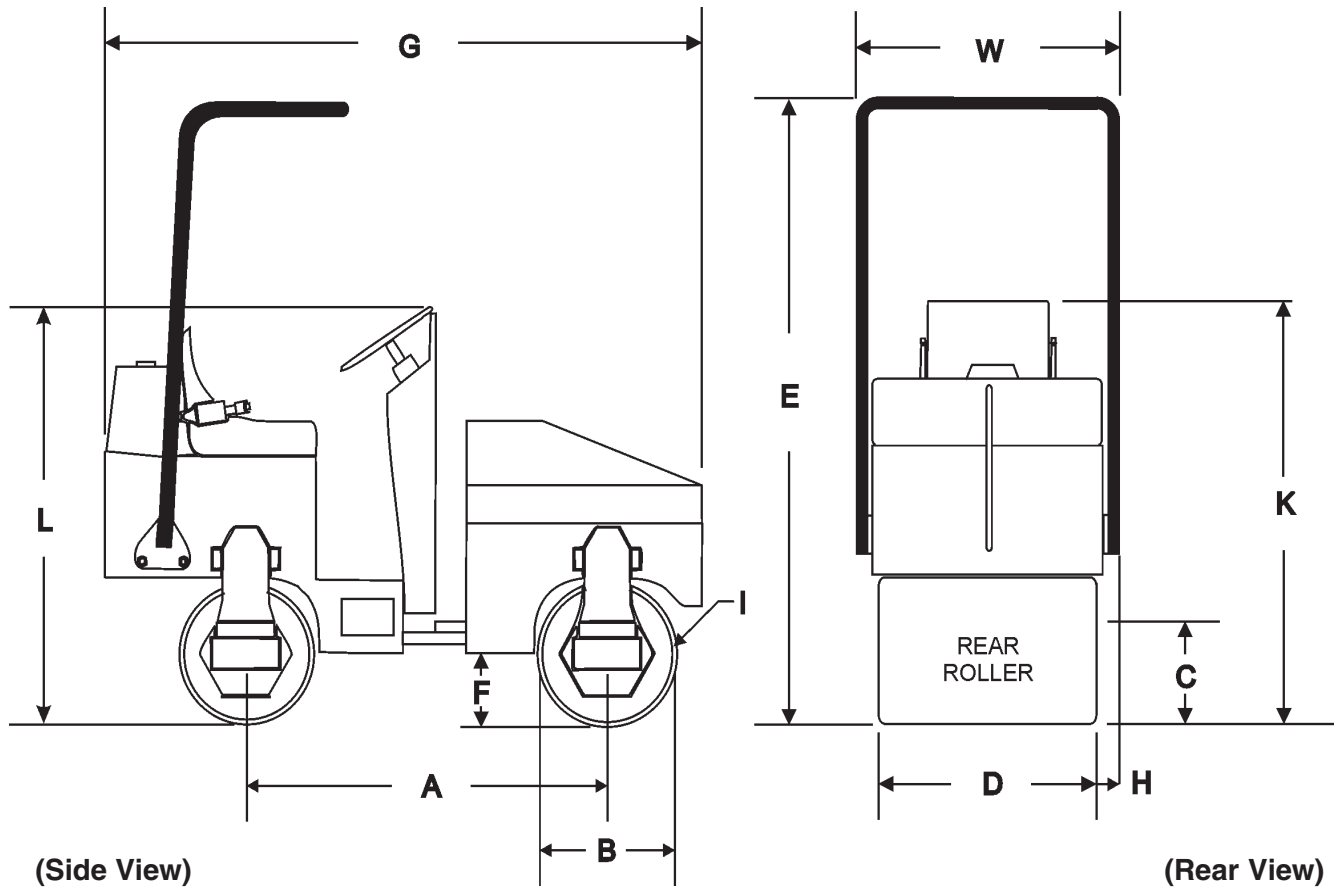

Figure 1. AR-13D Roller Dimensions

Table 3. AR-13D Dimensions		
Wheelbase	A	45.0 in. (1,143 mm.)
Drum Diameter	B	22.6 in. (574 mm.)
Curb Clearance	C	7.75 in. Left, 19.0 in. Right ( 197 mm., 483 mm.)
Drum Width	D	35.7 in. (907 mm.)
Overall Height (with ROPS)	E	87 in. (2,210 mm.)
Ground Clearance	F	11.5 in. (292 mm.)
Overall Length	G	90.5 in. (2,147 mm.)
Wall Clearance	H	1.75 in. Left, 1.25 in. Right ( 45 mm., 32 mm.)
Drum Thickness	I	.38 in. (10 mm.)
Overall Width	J	38.25 in. (972 mm.)
Seat Height	K	63 in. (1,600 mm.)
Steering Wheel	L	60 in. (1,524 mm.)

# AR-13D RIDE-ON ROLLER — GENERAL INFORMATION

The AR-13D roller has been designed for asphalt application and compaction of granular soils used in site preparation. Use the machine only for the purpose intended and by experienced personnel who understand this operating manual and all safety decals. Typical applications for this roller are driveways, patch work and road repairs. Standard features included with this roller are articulated steering, double drum hydrostatic drive, front drum vibration, high curb clearance and on board water capability.

## POWER PLANT

The AR-13D roller is powered by a Briggs & Stratton DM 850D, liquid cooled, diesel engine rated at 23.6 hp @3,600 rpm. The engine is of a lightweight design and is exceptionally well balanced for low vibration.

## HYDRAULIC SYSTEM

The Briggs & Stratton DM 850D diesel engine drives an axial hydraulic, variable displacement pump which is manually controlled via a cable control system. Pump flow is directed through an aluminum block manifold which provides the control for the 3 hydraulic motors.

The hydraulic drum drive system incorporates a parallel closed loop configuration operating at a maximum pressure of 2,900 psi. In addition this hydraulic system offers a "**free wheel valve**" which allows the roller to be towed in the event of an emergency.

## COMPACTION SYSTEM

The compaction force is delivered by a 36-inch wide steel drum with beveled edges to help prevent asphalt **marring**. A fully enclosed hydrostatic drive system offers a variable speed control as well as smooth acceleration and braking.

Connected to the axial hydraulic pump is a gear pump that provides power for the drum vibratory system and the articulating steering system. Oil from this pump flows to the manifold control valve block and then to a hydraulic motor which rotates the eccentric weights inside a sealed housing containing oil to lubricate the bearings.

A pushbutton switch located on top of the gearshift lever when pressed activates a **hydraforce** valve that engages or disengages the vibratory action. The drum's vibratory action generates 3,100 lbs. (1,406 Kg.) of centrifugal force at a frequency of 4,000 vpm (vibrations per minute). If the vibration appears to be weak or slow, allow the machine to warm-up thoroughly, and check the hydraulic oil level. Add hydraulic oil if necessary.

The vibrator housing and drum are shock mounted to isolate the engine compartment and operator from vibration.

The roller nominally has an operating weight of 3,088 lbs (1,400 Kg.), but can be increased to 3,309 lbs (1,500 Kg.) by adding water ballast to the rear drum.

## HYDRAULIC OIL FILTER SYSTEM

The hydraulic system oil is filtered by a screen type filter located in the reservoir filler neck, then doubled filtered within the system first by a 40 micron mesh-type suction filter located in the tank and the by a **Zinga** 10 micron, cartridge style spin-on return line filter.

## ARTICULATED STEERING SYSTEM

Power for the articulated steering system, which uses a single hydraulic cylinder is provided by the gear pump. This steering system can produce an inside turning radius of 109 inches (2.77 meters).

## SPRINKLER SYSTEM

A 40 gallon (152 liters) water tank with a gravity feed spray bar is provided for wetting the roll for asphaltic pavement rolling.

The water system is fully adjustable from the operator's position by adjusting the two water valves. The front valve controls the water supply to the front drum, and the rear valve controls water to the rear drum.

Before starting an asphalt rolling job, be sure all spray bar holes are clear of dirt or foreign matter and are working. Always use clean fresh water in the water tank. To prevent rust and foreign debris from clogging the spray bar holes, drain and flush water tank and spray bars every 30 days.

## LIFTING THE ROLLER

When lifting of the roller is required, attach a suitable hook or shackle to the **lifting eye** of the roller. These lifting points (4) are marked by a lifting hook decal. Make sure the lifting device is capable of lifting 4,000 lbs. (1,814 Kg).



## DANGER - Clear Obstacles from Area

Before operating the roller, make sure that personnel and obstacles are free from the roller's path. **Serious injury** or even **death** can result!

The forward-reverse control lever operates the hydrostatic pump which governs the roller speed and direction of travel. The speed in which movement of this lever is made is directly related to the amount of pressure that is applied to the travel lever in each direction. Travel speed is infinitely variable from 0 to 4.8 mph. The neutral position of this lever will cause the roller to stop.

# AR-13D RIDE-ON ROLLER — GENERAL INFORMATION

## **!** DANGER - Transporting Safety

**DO NOT** allow personnel to **stand under** or **near** any suspended machine. **Serious injury** or **death** may result.

## **!** CAUTION - Use CERTIFIED Lifting Devices

**ONLY!** use approved certified lifting devices capable of lifting at least 4,000 lbs. (1,814 Kg.).

## **!** CAUTION - Lifting the Roller

When lifting of the roller is required, only use the provided **lifting eyes** to lift the roller. Using other sections of the roller for lifting purposes may cause severe damage to the roller.

### OPERATING ON SLOPES

Special care must be taken when operating the roller on hills or slopes. There exist the possibility of serious injury to the operator and severe damage to the roller in the event of a roll over. **ALWAYS** operate the roller up and down hills rather than from side to side. For safe operation hillside slopes should not exceed 12 degree (27 % grade). See Figure 2 below.

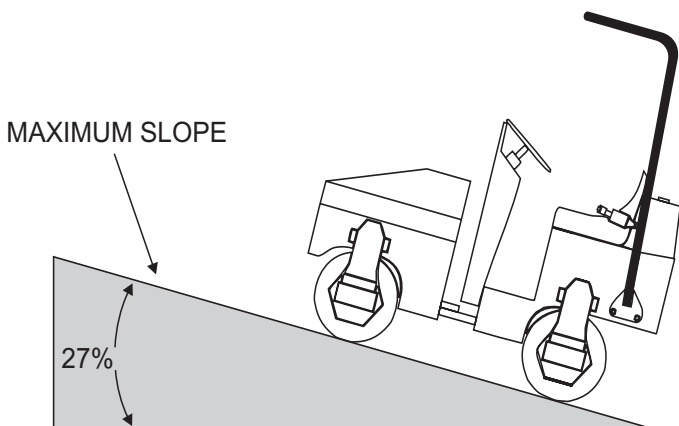

Figure 2. Recommend Slope

### Tipping (Rollovers)

**NEVER!** operate the roller on side slopes (Figure 3). The possibility exist that the roller could tip over (roll over), thus causing bodily harm even death and serious damage to the equipment.

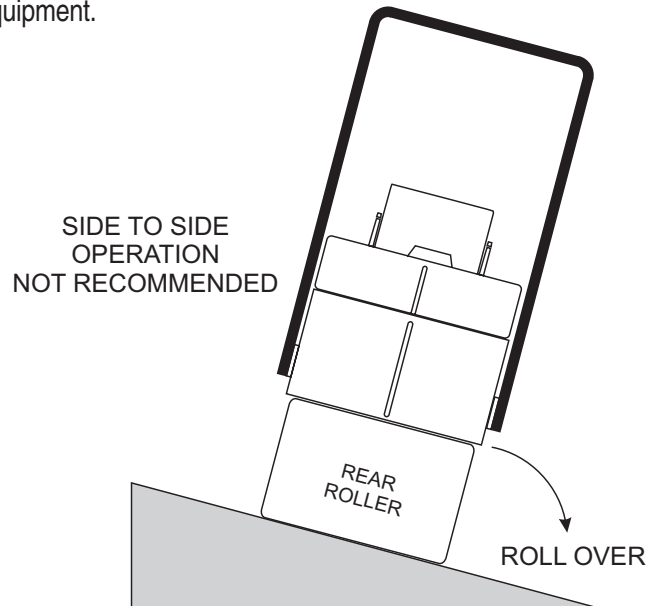
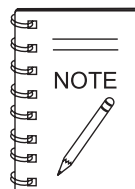

Figure 3. Tipping (Rollover)



**NEVER!** operate the roller on **side slopes**. The roller may tip over causing injury to personnel and severe damage to the equipment

In the event the roller does tip over, if at all possible, try to shut-down the engine by turning the ignition key to the **OFF** position. Extreme care must be taken to prevent damage to the engine. When the roller has been tipped over, oil from the engine crankcase can flow into the combustion chamber, which can severely damage the engine the next time it is started.

**IMMEDIATELY** after a unit has tipped over upright the unit as soon as possible to prevent oil from leaking into the combustion chamber.

## **!** CAUTION - Roller Rollover Safety

To prevent damage to the engine after a rollover, the roller must **NOT** be started. **NEVER** start a roller after a rollover. **CONTACT** your nearest authorized multiquip dealer for instructions or servicing.

# AR-13D RIDE-ON ROLLER — ROLLER COMPONENTS

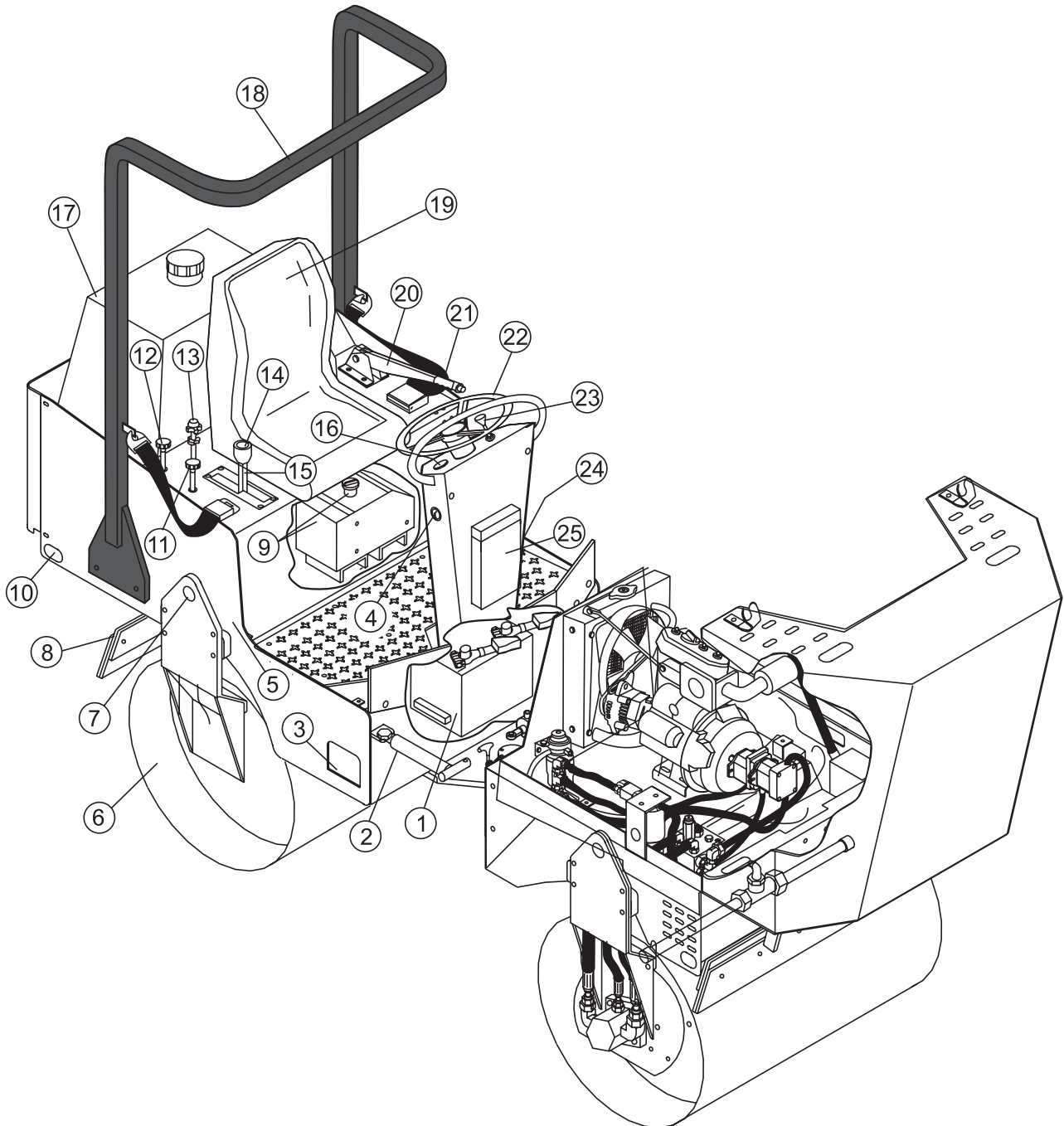
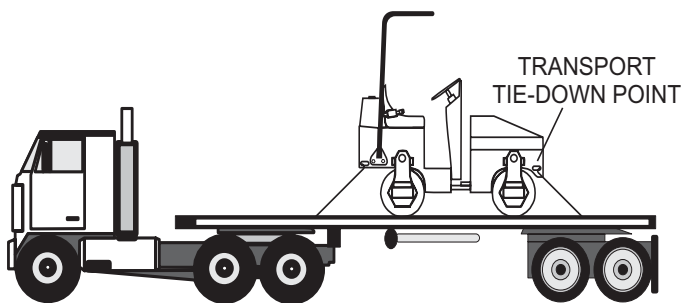

Figure 4. Roller Components 1

## AR-13D RIDE-ON ROLLER — ROLLER COMPONENTS

Figure 4 shows the location of the components and basic components for the AR-13D compaction roller. The function of each component or control is described below:

1. **Battery** – Provides +12VDC to the electrical system, and is located underneath foot plate. Replace only with recommended type battery, see specification Table 1.
2. **Articulating Locking Bar** – Always make sure that the articulating locking bar is engaged during lifting, transport and maintenance.
3. **Foot Step** – To lift yourself onto the roller's platform, place foot into foot step, then grab hold of hand rail.
4. **Ignition Switch** – With key inserted, turn clockwise to start the engine.
5. **Rear Sprinkler System** – A gravity feed spray bar is provided for the wetting the roll for asphalt pavement.
6. **Rear Roller** – This roller is a 30 inch wide **steel drum** with beveled edges (no vibration). The beveled edges help prevent asphalt marring.
7. **Lifting Point** – Attach a crane or suitable lifting device to this point when lifting of the roller is required.
8. **Rear Scrapper** – This adjustable rear scrapper blade helps prevent the buildup of material between the drum and frame.
9. **Fuel Tank/Fuel Gauge** – The fuel capacity of the fuel tank is 9.5 gallons (36 liters). Read the gauge on top of the fuel cap to determine if fuel level is low. Fill with diesel fuel. To gain access to the fuel tank, **tilt the front seat forward**. Fuel tank has a spill containment feature
10. **Tie-Down Transport Point** – Attach a chain or suitable tie-down device to this point when transporting of the is required.



11. **Front Spray Control Valve** – This valve controls the flow of water to the **front spray bar**. Turn the water valve to the **open** position (counterclockwise) to let water flow, return this valve to the **closed** position (clockwise) when water is not required.

12. **Rear Spray Control Valve** – This valve controls the flow of water to the **rear spray bar**. Turn the water valve to the **open** position (counterclockwise) to let water flow, return this valve to the **closed** position (clockwise) when water is not required.
13. **Throttle Control** — Pull all the way out to achieved maximum engine RPM's. To idle the engine, push the **RED** stop button inwards all the way.
14. **Vibration Control Button** – Press this button to activate the eccentric that will produce a vibration frequency of 4,400 vpm (vibrations per minute). Pressing the button again will stop the vibrations.
15. **Shift Lever** — Push the lever **forward** to makethe roller travel in a forward direction, pull the lever **backward** to make the roller travel in a reverse direction. Maximum travel speed is 4.8 MPH ( 7.7 KPH). Center position is neutral, no travel.
16. **Hour meter** — Indicates the number hours the unit has been in use.
17. **Water Tank** — Remove filler cap and fill with water. Water tank capacity is 40 gallons (152 liters). To determine if water level is low, visually inspect water level gauge (tube) at rear of roller. Add water as necessary.
18. **Roll-Over Bar** — This unit may be equipped with a **Roll Over Protection System (ROPS)** to protect the operator when the roller is used on slopes, open trenches, sharp turns, slippery surfaces or objects in the rollers's path of travel.
19. **Operator's Seat** — A contoured seat that provides visibility of both front rear drum edges during operation. **NEVER!** start the roller unless seated in the operator's seat.
20. **Parking Break Lever** — Pull the lever upward to set the parking break. To release the parking break, press and hold the button on top of the lever and push lever downward.
21. **Seat Belt** — When using the roller in working conditions always have the operator wear the seat belt. **NEVER** use the roller without a seat belt. If the seat belt becomes worn or damaged, have it replaced immediately.
22. **Steering Wheel** — Use this wheel to steer the roller.
23. **Engine Status Indicator Gauge** — Indicates oil temperature, water temperature, glow plug and battery.
24. **Hydraulic Motor** – This hydraulic motor provides control for the **rear** of the roller
25. **Documentation Box** — Maintain and store **at all times** Operation, Parts, and Engine manuals in this box.

## AR-13D RIDE-ON ROLLER — ROLLER COMPONENTS

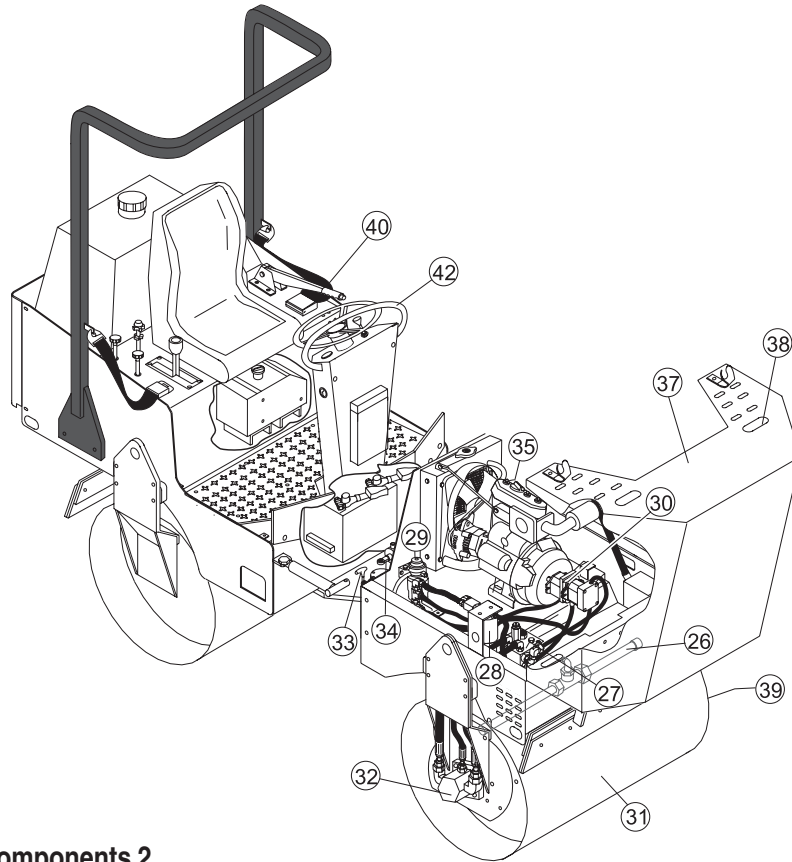

Figure 5. Roller Components 2

Figure 5 shows the location of additional components for the AR-13D compaction roller. The function of each component or control is described below:

26. **Front Sprinkler System** – A gravity feed spray bar is provided for the wetting the roll for asphalt pavement.
27. **Hydraulic Manifold** – Aluminum block that controls the flow of hydraulic pressure to the various hydraulic motors and other components required to control the roller.
28. **Hydraulic Oil Filter** – Filters return oil from the front and rear hydrostatic motors.
29. **Fuel Filter/Fuel Pump** – Electrical device that pumps fuel from the fuel tank to the carburetor.
30. **Hydraulic Pump** – This unit incorporates an axial variable displacement hydraulic piston pump.
31. **Front Ride-on Tandem Drum Roller** – This roller is a 30 inch wide **steel drum** with beveled edges. The beveled edges help prevent asphalt marring.
32. **Hydraulic Motor** – This hydraulic motor controls the rotation of the vibratory system.
33. **Bunjee Latch** – Pull this rubber latch upward and back to gain access to the engine/pump compartment. There is one rubber latch located on each side of the unit.
34. **Steering Cylinder** – Controls direction of roller.
35. **Engine** – This roller incorporates a Briggs & Stratton DM850D, liquid-cooled diesel engine rated at 23.6 hp at 3,600 rpm.
36. **Hydraulic Fluid Filler Port** – Remove this cap to add hydraulic fluid. Fill with type ISO 46 anti-wear hydraulic fluid.
37. **Compartment Hood** – Houses the engine, hydraulic manifold, accessory relay, hydraulic oil filter, hoses, and hydraulic pump. To lift the compartment hood, release the rubber bunjee latches located on each side of the hood.
38. **Compartment Hood Lift Point** – Place hand here then lift upwards to lift compartment hood.
39. **Hydraulic Motor** – This hydraulic motor drives the roller during operation.
40. **Rear Drum Zerk Grease Fitting** – Grease this fitting bi-weekly. See maintenance section of this manual.
42. **Hand Rail** – Grab hold of this hand rail when lifting yourself onto the operator's platform.

# AR-13D RIDE-ON ROLLER — ENGINE COMPONENTS

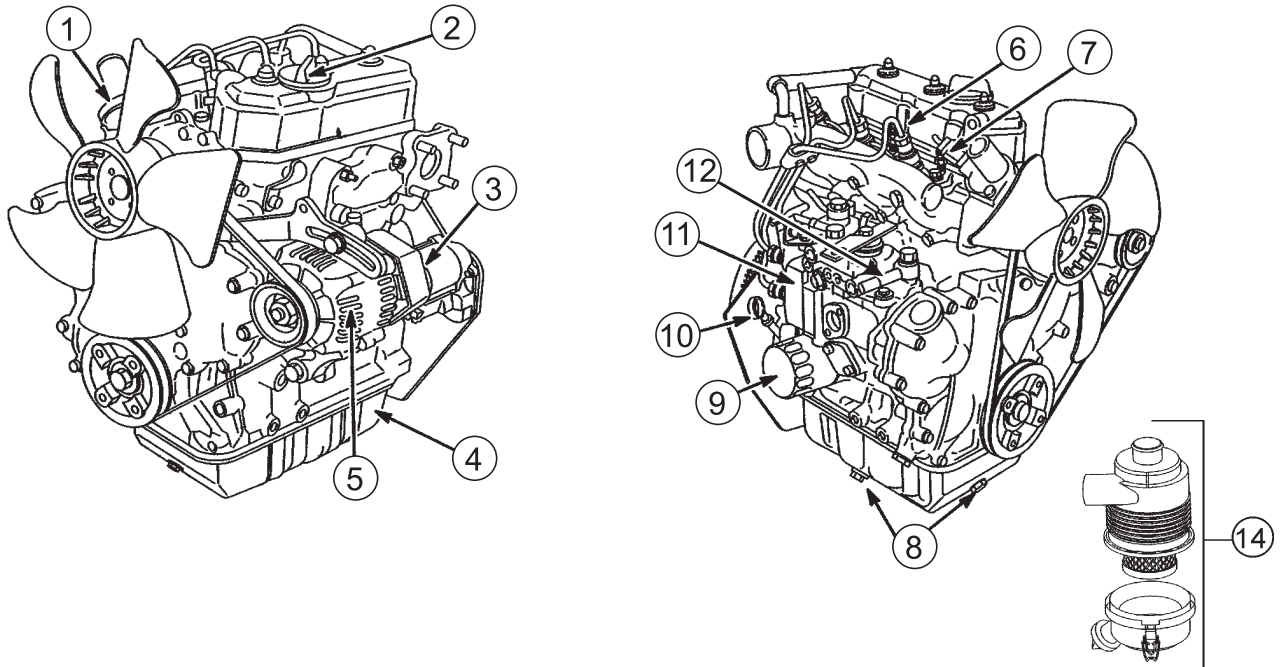

Figure 6. B&S 850D Diesel Engine Controls and Components

## INITIAL SERVICING

The engine (Figure 6) must be checked for proper lubrication and filled with fuel prior to operation. Refer to the manufacturer's engine manual for instructions & details of operation and servicing.

1. **Thermostat** – Regulates the temperature of the engine coolant.
2. **Oil Filler Cap** – Remove to add engine oil.
3. **Starter** – Starts engine when ignition key is rotated to the "ON" position
4. **Oil Pan**– Holds a maximum of 3.5 quarts (3.3 liters) of motor oil.
5. **Alternator**– Provides charge for battery and voltage for the +12 VDC electrical system.
6. **Injection Nozzle** – Injects diesel fuel into the cylinder.
7. **Glow Plugs** – Heating element used for starting the engine in cold weather conditions.
8. **Oil Drain Plugs** – Remove to drain crankcase oil. Fill with recommended type oil as listed in Table 4.
9. **Oil Filter** – Spin-on type, filters oil contaminants.
10. **Oil Dip Stick** – Remove to check amount and condition of oil in crankcase. Refill or replace with recommended type oil as listed in Table 4.

12. **Injector Pump**– Provides fuel under pressure to the injector nozzles.
14. **Air Filter** – Prevents dirt and other debris from entering the fuel system. Unsnap air filter cover to gain access to filter element.

**! WARNING - BURN HAZARD**



Engine components can generate extreme heat. To prevent burns, **DO NOT** touch these areas while the engine is running or immediately after operating. **NEVER** operate the engine with the muffler removed.

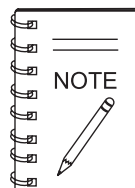

Operating the engine without an air filter, with a damaged air filter, or a filter in need of replacement will allow dirt to enter the engine, causing rapid engine wear.

# AR-13D RIDE-ON ROLLER — INSPECTION

## Before Starting

1. Read safety instructions at beginning of manual.
2. Clean the **ROLLER**, removing dirt and dust, particularly the engine cooling air inlet, carburetor and air cleaner.
3. Check the air filter for dirt and dust. If air filter is dirty, replace air filter with a new one as required.
4. Check carburetor for external dirt and dust. Clean with dry compressed air.
5. Check fastening nuts and bolts for tightness.



3. Check the oil level shown on the dipstick (Figure 8).

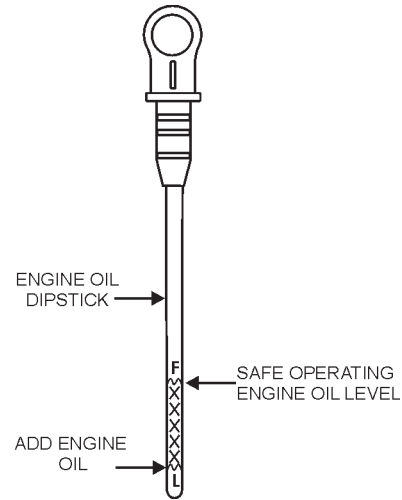

Figure 8. Engine Oil Dipstick

## Engine Oil Check

1. To check the engine oil level, place the roller on secure level ground with the engine stopped.
2. Remove the dipstick from its holder (Figure 7) and wipe it clean.

DIPSTICK

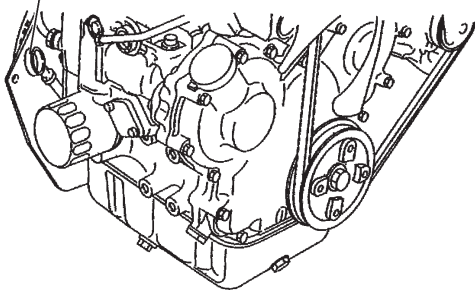

Figure 7. Engine Oil Dipstick (Removal)

4. If the oil level is low, remove the oil filler cap (Figure 9) and fill to the safe operating level (F) as indicated by the dipstick. Pour oil slowly. Fill with recommended type oil as listed in Table 4. Maximum oil capacity is 3.5 quarts (3.3 liters).

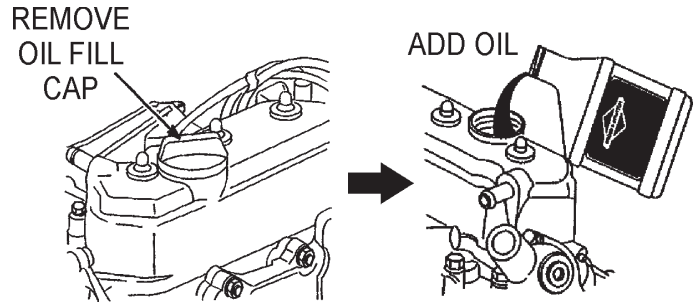
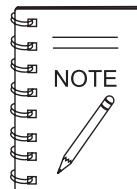

Figure 9. Engine Oil Filler Port

Table 4. Motor Oil Grade

Season or Temperature	Grade of motor oil (higher than MS class)
Spring, Summer or Autumn +120° F to +15° F	SAE 30
Winter +40° F to +15° F	SAE 30
Below +15° F	SAE 10W-30



To assure proper venting, always remove the dipstick when adding oil. **ALWAYS** be sure to check the engine oil level prior to starting the engine.

# AR-13D RIDE-ON ROLLER — INSPECTION

## Fuel Check

### **! DANGER - EXPLOSIVE FUEL**

**NEVER** fill the fuel tank while the engine is running or in the dark. Fuel spillage on a hot engine can cause a fire or explosion. If fuel spillage occurs, wipe up the spilled fuel completely to prevent fire hazards.



**DO NOT** smoke while refueling, motor fuels are highly flammable and can be dangerous if mishandled.

1. To check the engine fuel level, place the roller on secure level ground with the engine stopped.
2. Tilt the operator's seat (Figure 10) **forward** to gain access to the fuel tank.

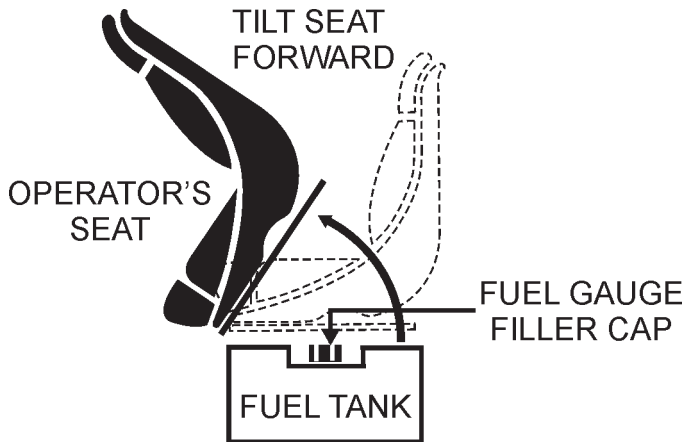

Figure 10. Fuel Tank Access

3. Read the fuel gauge (Figure 11) located on top of the fuel tank to determine if fuel level is low.



Figure 11. Fuel Gauge

4. If the fuel level is low, remove the fuel filler cap/gauge and fill with #2 diesel fuel. Wipe up any spilled fuel immediately.
5. Pay attention to the fuel tank capacity when replenishing fuel (Figure 12). Refer to the fuel tank capacity listed on page 13, AR-13D Roller Specification Table 1.

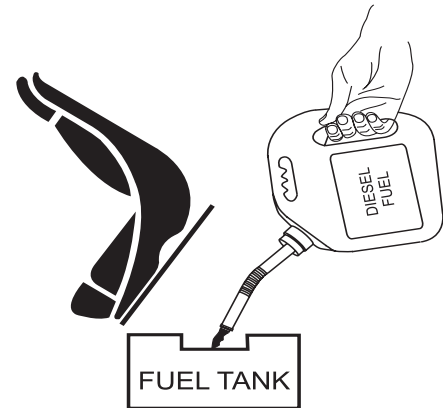

Figure 12. Adding Fuel

6. After replenishing fuel, make sure fuel cap is securely tighten to fuel tank. Return operator's seat to normal operating position.

## Hydraulic Oil Check

1. To check the hydraulic oil level, place the roller on secure level ground with the engine stopped.
2. Visually inspect the hydraulic oil sight glass (Figure 13) located on the right rear of the front drum. For normal operation the hydraulic oil level must be below the top and above the bottom of the sight glass. **DO NOT OVERFILL!**

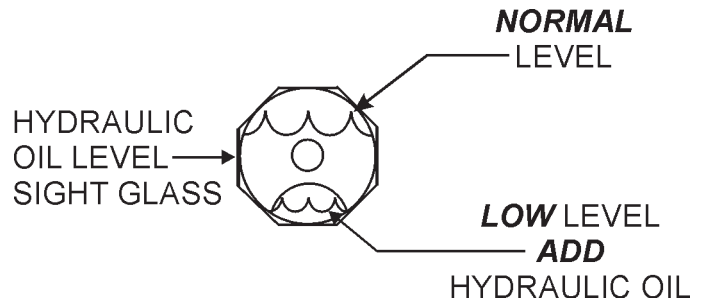

Figure 13. Hydraulic Oil Sightglass

4. If the hydraulic oil level is low, remove the hydraulic oil cap (Figure 14) and fill with type **ISO 46 anti-wear type hydraulic oil** to the recommended operating level.

# AR-13D RIDE-ON ROLLER — INSPECTION

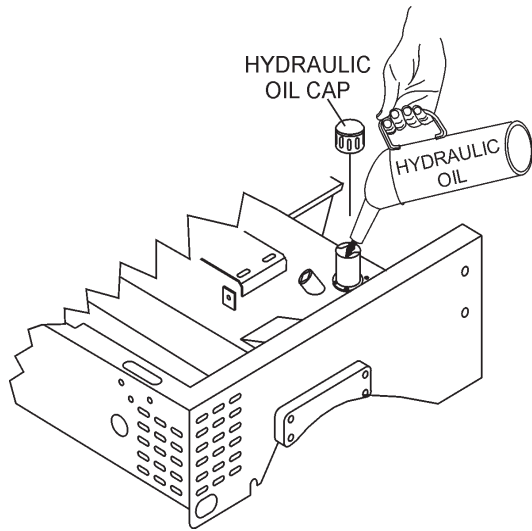

Figure 14. Hydraulic Oil Reservoir Filler Port

## Battery Check

A 12-volt DC battery (Figure 16) is shipped dry, and will require a proper electrolyte level for operation.

**ALWAYS** be sure that the battery cables are properly connected to the battery terminals as shown below. Generally the **RED** cable will be connected to the positive terminal of the battery, and the **BLACK** cable will be connected to the negative terminal of the battery.

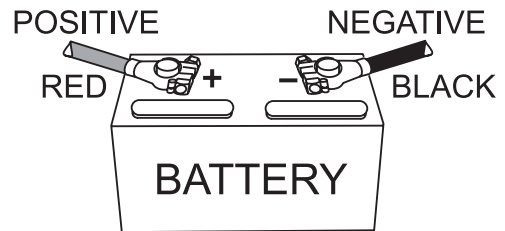

Figure 16. Battery

## Water Tank Check

1. To check the water tank water level, place the roller on secure level ground.
2. The amount of water inside the water tank can be visually inspected by reading the water tube (Figure 15) that runs vertically along the water tank at the rear of the roller. This tube indicates the amount of water inside the water tank. Total tank capacity is 40 gallons (152 liters)

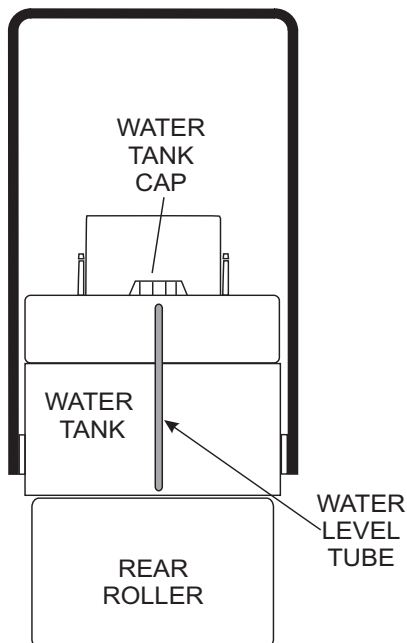

Figure 15. Water Tank

## ! WARNING - Battery Polarity Safety

If the battery cables are connected incorrectly, electrical damage will occur causing damage to the roller's electrical circuits. Pay close attention to the polarity of the battery when connecting the battery.

# AR-13D RIDE-ON ROLLER — INITIAL START-UP

## Initial Start-up Instructions

### Starting

#### **!** CAUTION - General Operation Safety

**DO NOT** attempt to operate the roller until the Safety, General Information and Inspection sections have been read and understood.

1. Place your foot into the roller's foot step, grab hold of the hand rail located on the steering console, and lift yourself onto the platform.
2. Sit down in the operators seat and adjust the seat for a comfortable position, then fasten the seat belt (Figure 17) around your waist. **NEVER!** operate the roller without the seat belt being fastened, serious injury could occur if the seat belt is not used.

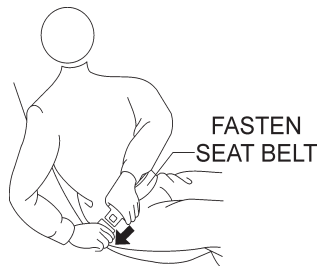

Figure 17. Securing Seat Belt

3. Before starting engine, make sure the immediate area is free of obstructions and debris that may lay in the roller's path.
4. Make sure that the roller's shift lever (Figure 18) is placed in the **neutral position**.

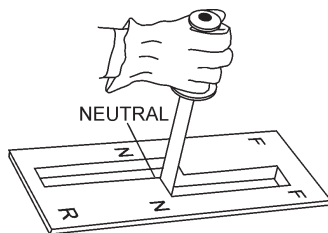

Figure 18. Shift Lever

5. **PUSH** the "RED" button (Figure 19) on the throttle control and pull the round black knob about halfway out. Make sure that the throttle lock knob has been dis-engaged.

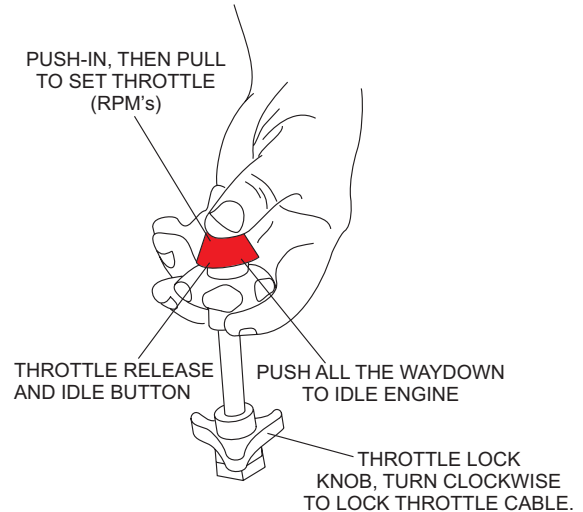

Figure 19. Throttle Control

6. Insert ignition key into ignition switch (Figure 20), turn key clockwise until glow plug indicator light turns **ON**, keep key in this position until glow plug indicator light turns **OFF**. Continue turning ignition all the way clockwise until engine starts, release key.

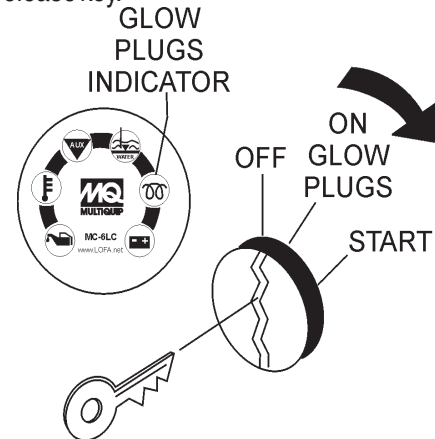

Figure 20. Ignition Switch

7. If the engine does not start, repeat steps 1 through 7 or consult the troubleshooting guide contained in this manual.
8. Let the engine warm for 3 to 5 minutes before using roller. Check for fuel and oil leaks, and noises that would associate with a loose guard and/or covers.
9. If necessary return the choke knob to the full **OPEN** position.

# AR-13D RIDE-ON ROLLER — OPERATION

## OPERATION

### Parking Brake

1. To release the parking brake, press and hold the release button (Figure 21) pull up slightly on the parking lever, then push the parking brake lever all the way down.

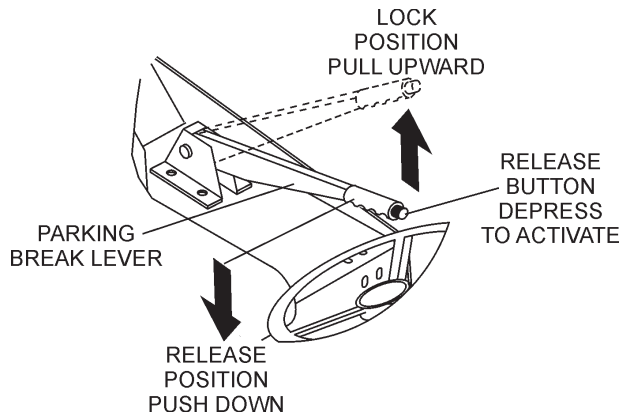

Figure 21. Brake Release Lever

### Shift Lever

1. To make the roller move in a **forward direction**, move the shift lever forward as shown in Figure 22.

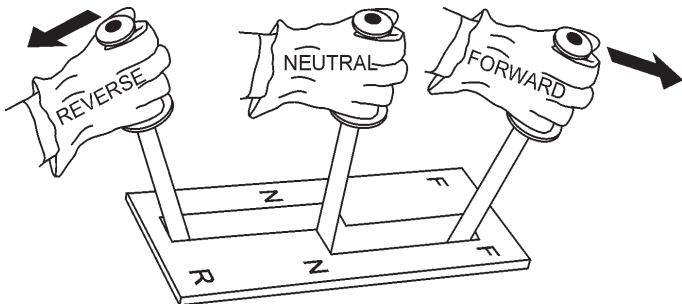

Figure 22. Shift Lever

2. Remember the speed of the roller is directly proportional to the amount of pressure being applied to the lever in each direction. Travel speed is between 0 and 4.8 mph (7.2 kph).

### CAUTION - Drive System Safety

**ALWAYS** allow the roller to come to a complete stop before changing the direction of travel. Changing directions before the roller comes to a complete stop will result in **excessive force** being applied to the transmission and drive system, which will reduce the over service life of the system.

3. Try maneuvering the roller a few times to get familiar with the handling. Also place the travel lever in the opposite direction to get acquainted with driving in reverse.
4. Make sure that the roller comes to a complete stop (neutral) before placing the travel lever in either a forward or reverse position.

### Vibration Button

1. To begin the vibratory action, **press** the vibratory pushbutton switch located on top of the travel lever as shown in Figure 23. The pressing of this switch will generate 3,100 lbs. (1,406 Kg.) of centrifugal force at a frequency of 4000 vpm (vibrations per minute) to the **front** drum.

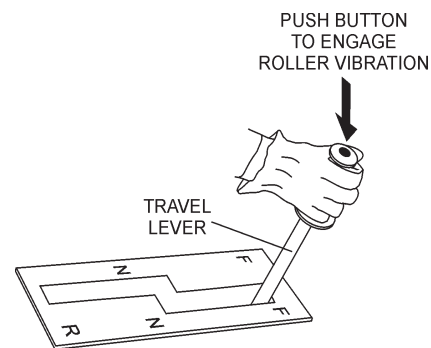

Figure 23. Vibration Pushbutton Switch

2. To stop the vibratory action, press the vibratory pushbutton switch again.

### Sprinkler Controls

1. If the application requires the wetting of a surface, front and rear drum sprinkler controls have been provided. These controls (Figure 24) are located to the bottom right of the operators seat. The **front** valve controls the water supply to the front drum spray bar and the **back** valve controls water flow to the back drum spray bar.

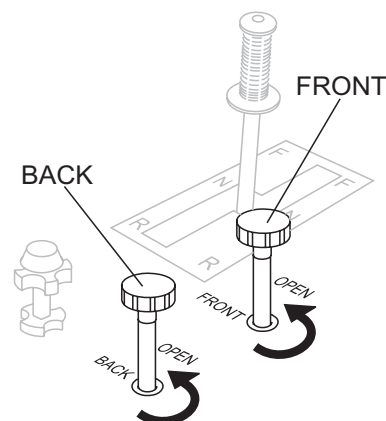

Figure 24. Sprinkler Controls

# AR-13D RIDE-ON ROLLER — MAINTENANCE

## Maintenance

Perform roller maintenance as indicated by Figure 25 and Table 5.

Figure 25. Roller Maintenance Schedule

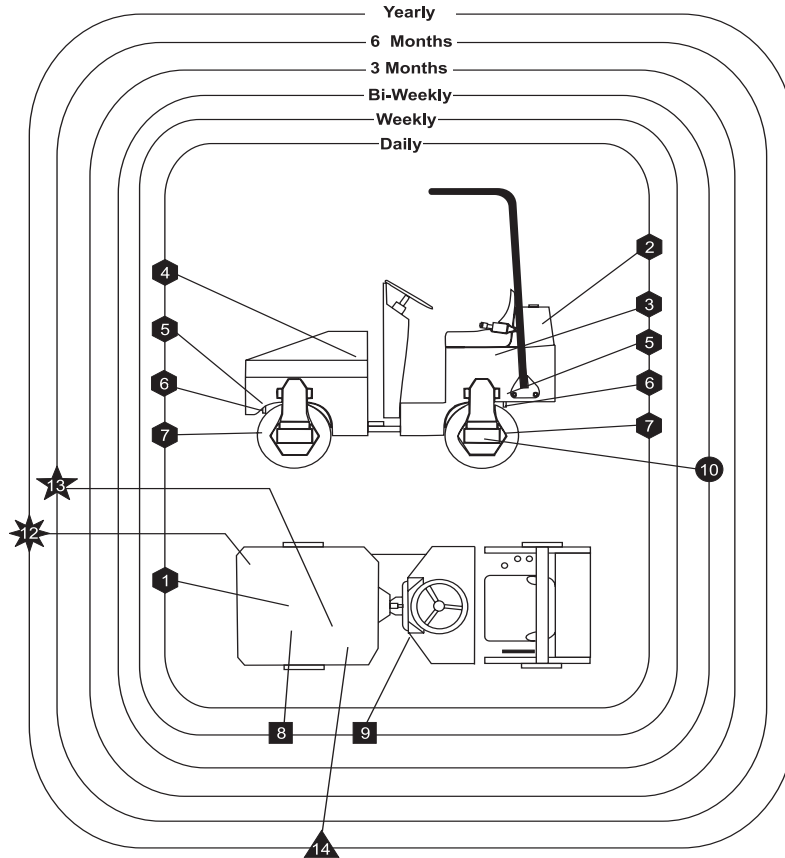

Table 5. AR-13H Roller Maintenance Schedule

	Daily	1	2	3	Interval	Notes
1	Engine Oil Level	X	X			See Table 4
2	Water Tank Level	X	X			
3	Fuel Level	X	X			
4	Hydraulic Oil Level	X	X			Use ISO 46 Type Hydraulic Oil
5	Sprinkler System	X				
6	Scraper	X	X			Replace when badly worn
7	Drums (Front/Rear)	X	X			
<b>Weekly</b>						
8	Air Filter	X	X			Replace paper element once a year.
9	Battery Liquid Level	X	X			
<b>Bi-Weekly</b>						
10	Zerk Grease Fitting (Rear Drum)		X		80 hrs. or Bi-Weekly	Use Type Alvania #2 or equivalent 3 shots max. <b>DO NOT</b> over grease.
<b>3 Months</b>						
12	Hydraulic Oil Filter (Return)			X	500 hrs.	Replace with same type filter.
<b>6 Months</b>						
13	Engine Oil Filter			X	20 hrs. or 1 month	After first 20 hrs, change oil filter every 6 months or 100 hrs.
<b>Yearly</b>						
14	Hydraulic Oil			X	1,100 hrs. or Once a year	Use ISO 46 Type Hydraulic Oil

1 = Check 2 = Refill/ Clean / Grease 3 = Replace

# AR-13D RIDE-ON ROLLER — MAINTENANCE

## Hydraulic Oil System

The hydraulic system consists of a two pump stack directly coupled to the engine. A hydraulic valve block (manifold) is provided for quick and easy testing and troubleshooting.

Hydraulic oil is filtered by a screen filter located in the tank filler neck, a **40 micron suction filter** located in the tank, and a **10 micron return filter**, with cold oil bypass valve located in the return circuit.

It is recommended that **ISO 46 type hydraulic oil** or equivalent be used when adding or replacing the hydraulic oil is required.

**DO NOT USE MULTI-VISCOSITY OIL.** Cleanliness is a very important part of proper hydraulic system operation. Hydraulic oil is not only used to transfer power; it also lubricates and cools the system components. Keeping the hydraulic system clean can help reduce costly repairs.

The hydraulic oil level sight glass is located on the right rear of the front drum, below the engine compartment. This level should be checked daily. Oil must be below the top and above the bottom of the sight glass. **DO NOT OVERFILL!** Care should be taken to clean the filler cap before adding oil to the system. If hydraulic oil has to be added, the machine should be inspected for leaks.

The **suction filter** (Figure 26) is located inside the hydraulic tank. This filter is attached to the fitting connected to the hydraulic pump suction hose.

The **return filter** (Figure 26) is located at the front of the engine compartment. Replace both filters according to the Table 5.

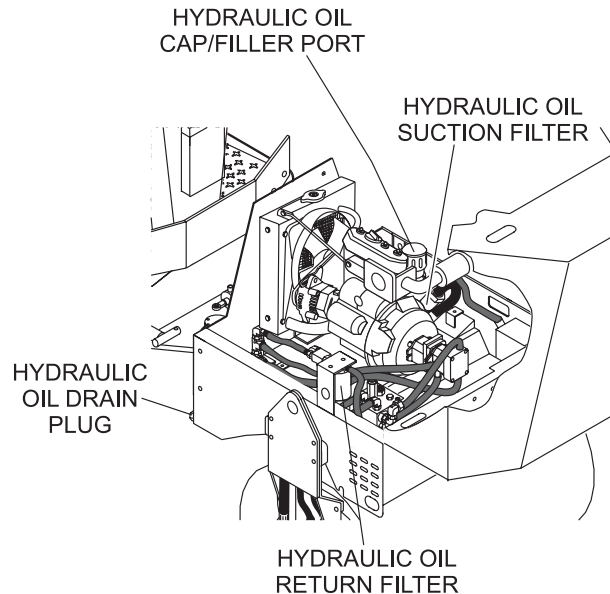

Figure 26. Hydraulic Filter Locations

## Changing Hydraulic Oil and Filters

1. Park the roller on a clean flat work area and set the parking brake.
2. Remove the **hydraulic oil drain plug** (Figure 26) and drain the hydraulic oil. Dispose of the used oil in an environmentally friendly manner. Replace the drain plug and tighten.
3. Remove the return filter and **install a new filter**. Dispose of the used filter in an environmentally friendly manner.
4. Disconnect the suction hose and remove the fitting from the tank. **Replace** the suction filter. Dispose of the used filter in an environmentally friendly manner. Replace the fitting and reconnect the suction hose.

## Freewheel Engagement Valve

This hydraulic system has a freewheel engagement valve allowing hydraulic oil to be bypassed. **Open** (turn allen wrench counter-clockwise) this valve (Figure 27) to engage the freewheel capability of the roller. When the valve is fully opened, ports **A** and **B** are allowed to connect, bypassing the oil to and from the drum drive motors.

Remember the freewheel engagement valve should only be used in emergencies when the roller cannot be driven due to engine or hydraulic system problems.

When towing of the roller has been completed, this valve **must** be **closed** (turn allen wrench fully clockwise) completely and the lock nut set. Failure to close this valve completely will result in low power, improper speed, and excessive hydraulic oil temperature.

## ⚠ CAUTION - HYDRAULIC SYSTEM HAZARD

**DO NOT** open hydraulic lines or loosen hydraulic fittings while engine is running! Hydraulic fluid under pressure can penetrate the skin, blind, cause burns or create other potentially dangerous hazards follow all safety instructions as described throughout this manual.

# AR-13D RIDE-ON ROLLER — MAINTENANCE

## **CAUTION - Freewheel Engagement Valve**

The freewheel engagement valve (towing) is only for **emergency use**. **DO NOT** move roller over 2 MPH or long distances as hydraulic system component failure could result.

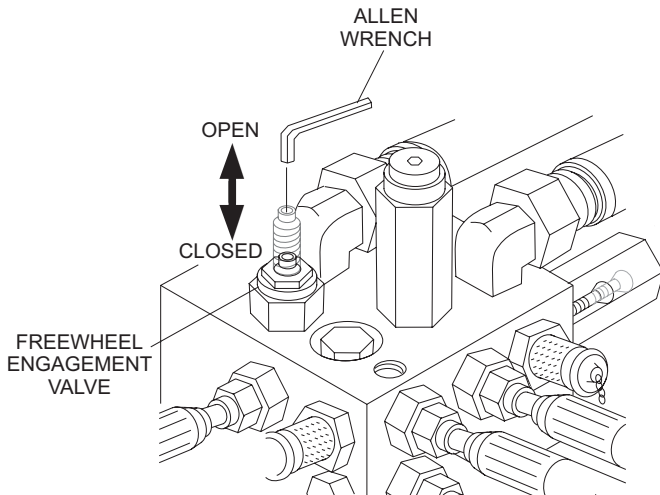

**Figure 27. Freewheel Engagement Valve**

### Drum Drive

The drum drive circuit is a **parallel, closed loop system** (Figures 29 and 30) consisting of a hydrostatic pump, two relief valves, a freewheel engagement valve, front and rear drum drive motors.

The hydrostatic pump is manually controlled by a cable connected to the forward/reverse shift lever located on the right side of the operator seat. When the shift lever is placed in forward, high-pressure oil is supplied by the hydrostatic pump to the valve block (**port A**). The valve block (manifold) directs this high-pressure oil to the front and rear drum drive motors. Return oil from the motors is returned to the valve block (**port B**) and is returned to the suction side of the hydrostatic pump.

When shifted into reverse, the high-pressure and suction ports on the hydrostatic pump are reversed. Oil flow is then in the opposite direction of forward (**port B** becomes high-pressure and **port A** becomes suction)

### Vibration and Steering

The vibration and steering system is an **open loop circuit** operated by a gear type pump. Separate relief valves control each circuit. This system consist of the gear pump, relief valves, electric vibration control valve, vibration drive motor, steering valve, and steering cylinder.

The vibration circuit is controlled by an electric control valve located on the valve block (manifold). This valve is controlled by the **“ON/OFF”** pushbutton switch mounted on top of the travel lever.

High-pressure oil is supplied by the pump to the valve block (**port P**) and is directed to the electric control valve. When the pushbutton switch is in the **“OFF”** position, this valve is **open** allowing oil to go to the steering valve, without driving the vibration motor.

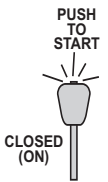

When the switch is in the **“ON”** position, the electric control valve **closes** and oil is directed out of **port 1** to the vibration motor. Return oil from the motor returns to the valve block via **port 2** and is directed to the steering valve.

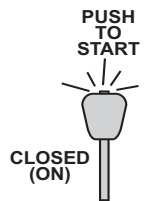

Steering is controlled by a **steering valve** and **cylinder** (Figures 29 and 30). The steering wheel is direct coupled to the steering valve controlling the oil flow to the cylinder. Oil supplied from the vibration circuit is directed to **port 3** which connects to **port P** of the steering valve. When steering is not being used, oil passes out of **port T** of the valve block and returns to the hydraulic tank. When the steering wheel is operated, the steering valve closes and oil is directed to ports **L** or **R** to extend or retract the steering cylinder.

### Rubber Scrapper Mat

Rubber scrapper mats have been provided for the cleaning of the front and rear drums. Adjust the scrapper mats as close as possible to the drums, using the slotted holes (Figure 28) provided. Replace these rubber mats when they become badly worn.

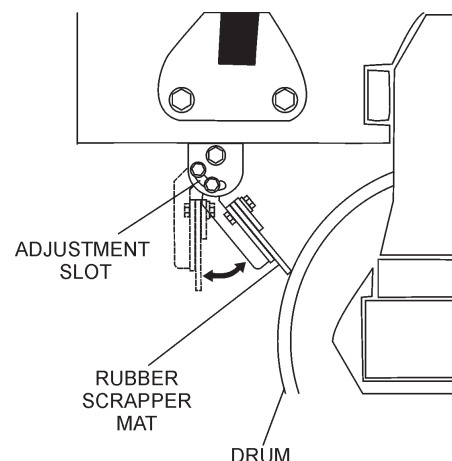

**Figure 28. Scrapper Bar Adjustment**

# AR-13D RIDE-ON ROLLER — MAINTENANCE

## Forward/Reverse Hydraulic Pressure Test

Park the machine on a solid flat surface and stop the engine. Set the parking brake and **block the front drum securely**.

1. Check hydraulic oil level by viewing the hydraulic oil sight glass. The hydraulic oil level must be below the top and above the bottom of the sight glass. **DO NOT OVERFILL!**
2. Adjust engine RPM (3,500 +/- 50 RPM)
3. Let engine run for 5 minutes, this will bring the hydraulic oil operating temperature to a minimum of 135° fahrenheit.
4. Check and repair all hydraulic leaks.
5. On the manifold block install a 5,000 psi pressure gauge (Figure 34) to the **forward** pressure quick disconnect test port 2
6. Run engine at full throttle.
7. Move the **travel lever** to the forward position. **MAKE SURE FRONT AND REAR DRUMS DO NOT SPIN.**
8. Read the pressure gauge. The **relief pressure** (roller drums blocked) will read 2,900 ± 145 psi. Under **normal operating** conditions this pressure will read 400-600 psi.
9. Return the travel lever to the **neutral** position and **stop** the engine.
10. Install the pressure gauge into the reverse quick disconnect **port 3** and repeat the above procedures. The relief pressure reading for the **reverse** test port 3 will be the same (2,900 psi). Again normal operation pressure for the reverse port will be 400-600 psi.

## Vibration Circuit Pressure Test

Place the front drum on soil, gravel, or a heavy rubber mat. **DO NOT ACTIVATE VIBRATION FEATURE ON CONCRETE OR HARD SURFACE!**

1. On the manifold block install a 5,000 psi pressure gauge to quick disconnect test port 1.
2. Start the engine and run at full throttle.
3. To start the vibration, **press** the pushbutton switch (vibration control) located on top of the travel lever. Under normal operating conditions this pressure will range between 800-1,000 psi.

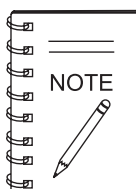

Vibration relief pressure is hard to read accurately using this test. It may be necessary to disconnect the pressure line to the vibration drive motor. Plug this line and re-test, pressure will be exact relief pressure. **DO NOT** perform this test for a long period of time — damage could occur.

## Steering Pressure Test

1. On the manifold block, install a 5,000 psi pressure gauge into quick disconnect test **port 1** (Figure 34).
2. Start the engine and run at full throttle.
3. Turn the steering wheel to the **left or right** (maximum) and hold. Read the steering relief pressure. The **relief pressure** reading for the **steering** test port 1 will be 700 psi. Again, under normal operating conditions, pressure for the steering port will be between 200-400 psi.

If maximum pressure cannot be reached, plug the steering cylinder pressure hoses and re-test. If pressure is correct the steering cylinder is leaking. **DO NOT ACTIVATE THE VIBRATION FUNCTION WHILE PERFORMING THIS TEST !**

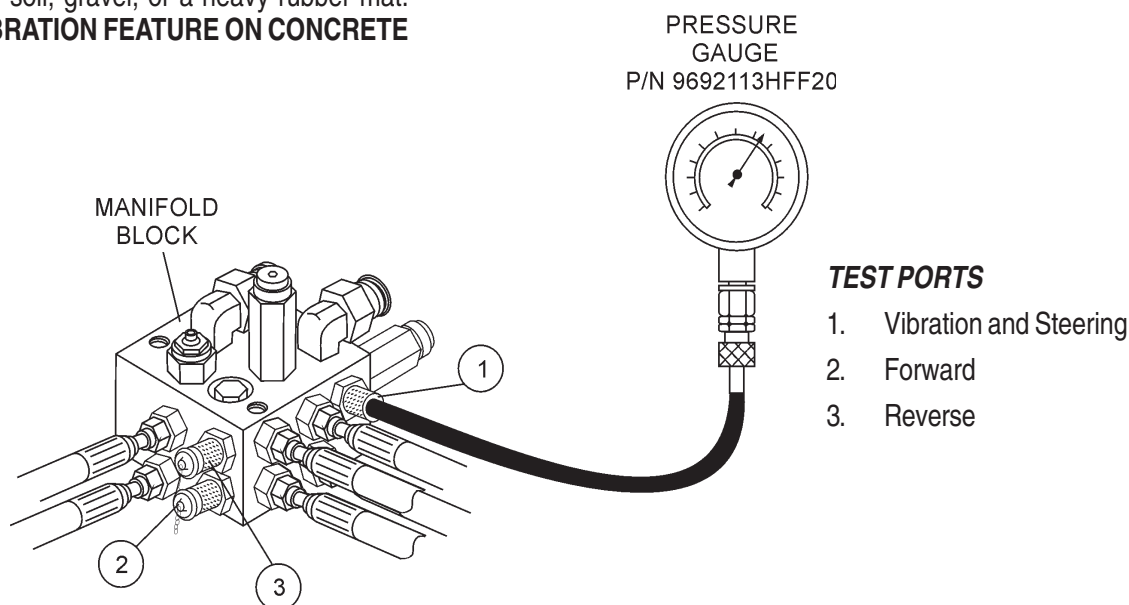
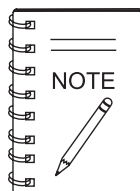

Figure 34. Manifold Test Ports

# AR-13D RIDE-ON ROLLER — MAINTENANCE

## Forward/Reverse Relief Valves Drive Adjustment

The **forward** and **reverse** relief valves (Figure 35) are shim type cartridge type and are located in the hydrostatic pump (not on the manifold block) under plugs 1 and 2. Plug 2 is located in the same location as plug 1, except it is on the bottom side of the pump. Relief valve 1 is **reverse** and 2 is **forward**.



Axle Pumps supplied **after 01/01/2003 DO NOT** have adjustable relief cartridges. The pressure is fixed at  $2,900 \pm 145$  psi. If the relief pressure is not within normal range, the complete cartridge must be replaced.

1. Clean the area around the cap.
2. Remove the cap.
3. Carefully remove the valve cartridge.
4. Using an **allen wrench**, remove the top nut (extreme care must be taken not to loosen existing shims, spring, or valve) Add or remove shims as required. **Adding** shims increases pressure; **removing** shims lowers pressure. One shim is equal to approximately 50 psi. Shim P/N is 34538.
5. Install the top nut and install valve in the pump cavity using extreme care not to bind.
6. Install the valve cap.
7. Re-test pressure, further adjustment may be needed if pressure is not correct.

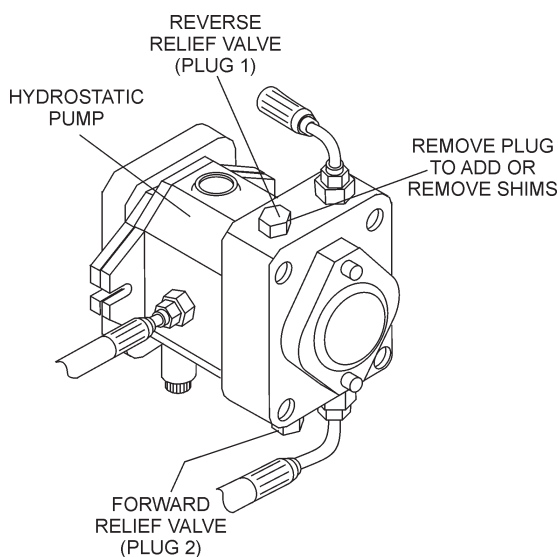

Figure 35. Adjusting Forward/Reverse Relief Valves

## Steering Relief Valve Pressure Adjustment

To adjust the relief valve steering pressure perform the following:

1. Insert an 8 mm allen wrench into steering relief **port 4** (Figure 36) on the manifold block.
2. On the manifold, connect at 5,000 psi pressure gauge into quick disconnect test **port 1**.
3. Start the engine and run at full throttle.
4. Turn the steering wheel to the **left or right** (maximum) and hold. Read the steering relief pressure. The **relief pressure** reading for the **steering** test port 1 will should be 700 psi.
5. If the steering relief pressure is not 700 psi, using the allen wrench adjust the pressure at **port 4** until the pressure gauge reads 500 psi.

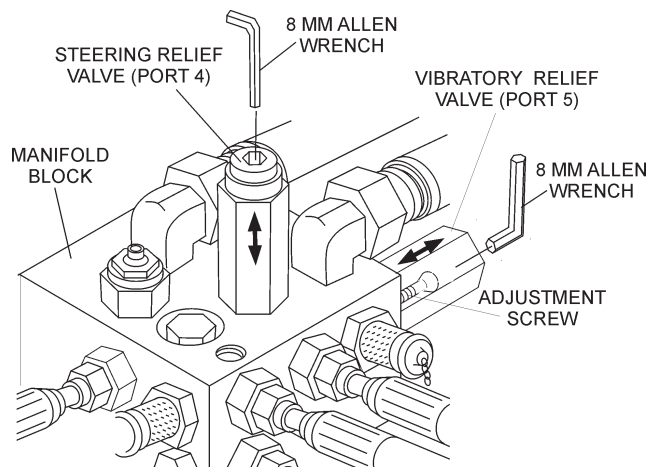

Figure 36. Steering and Vibration Relief Valves

## Vibration Relief Valve Pressure Adjustment

1. Insert an 8 mm allen wrench into steering relief **port 5** (Figure 36) on the manifold block.
2. On the manifold block, insert a 5,000 psi pressure gauge into quick disconnect test **port 1**.
3. Start the engine and run at full throttle.
4. To start the vibration, **press** the pushbutton switch (vibration control) located on top of the travel lever. The relief pressure should read 800 ~ 1,000 psi.
5. If the vibration relief pressure is not 800 ~ 1,000 psi using the allen wrench adjust the pressure at **port 5** until the pressure gauge reads correctly.

# AR-13D RIDE-ON ROLLER — MAINTENANCE

## Removing and Replacing Hydrostatic Pump

1. Set the parking brake.
2. Disconnect the battery.
3. Clean the pump and all connections.
4. Mark and disconnect all hoses and lines from the pump.
5. Disconnect the forward / reverse control cable.
6. Disconnect the pump support bracket.
7. Remove the engine mounting bolts.
8. Elevate the pump and engine assembly using a proper lifting device.
9. Disconnect and remove the hydrostatic pump assembly.
10. Repair or replace the hydrostatic pump as required.
11. Install the hydrostatic pump in the reverse order of removal, using *Loctite 271* on all mounting bolts and nuts.
12. Test operate. Test and adjust the forward and reverse relief pressures as required. Adjust the forward / reverse control cable.

## Removing and Replacing Vibration/Steering Pump

1. Remove the hydrostatic pump as per preceding instructions.
2. Remove all hoses and lines.
3. Disconnect the vibration / steering pump and remove.
4. Repair or replace pump as required.
5. Install the pump in the reverse order of removal, using *Loctite 271* on all mounting bolts and nuts.
6. Test operate. Test and adjust the forward and reverse pressure relief valves as required. Adjust the **forward/reverse control cable**. Test and adjust the vibration and steering pressure relief valves as required.

## Drums and Main Frame

The front drum is designed to apply vibration and compaction force to the operating surface for compaction. This vibration and compaction force is produced when the vibrator shaft is rotated. Maximum efficiency is achieved only when the engine is operated at full throttle.

A single drive motor is mounted on the left side of the drum and is shockmounted. This type of drive motor is designed for maximum torque and power.

The vibrator is driven by a gear motor coupled to the vibrator shaft. The vibrator assembly rotates inside of a sealed housing containing oil to lubricate the bearings. This side of the drum is also shock mounted.

### Front and Rear Drum Removal and Disassembly.

The removal and disassembly of the front and rear drums shall be referenced by Figures 37, 38, and 39 on the following pages. When reassembling the front drum use *Loctite 271* on all mounting hardware.

# AR-13D RIDE-ON ROLLER — MAINTENANCE

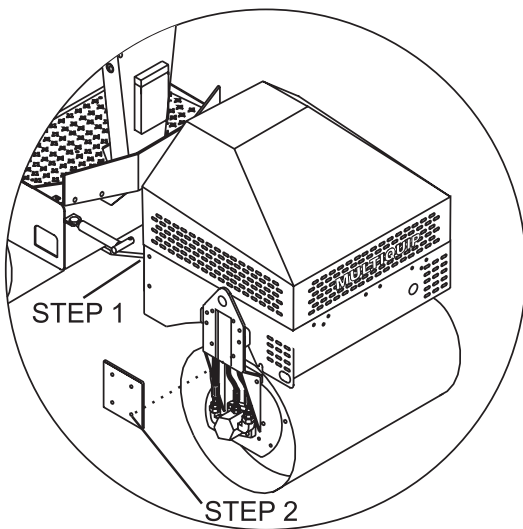

1. JACK FRAME UP SLIGHTLY AT ARTICULATION JOINT.
2. REMOVE THE FOUR ALLEN HEAD SCREWS HOLDING THE SIDE COVER OF THE DRUM SUPPORT PLATE.

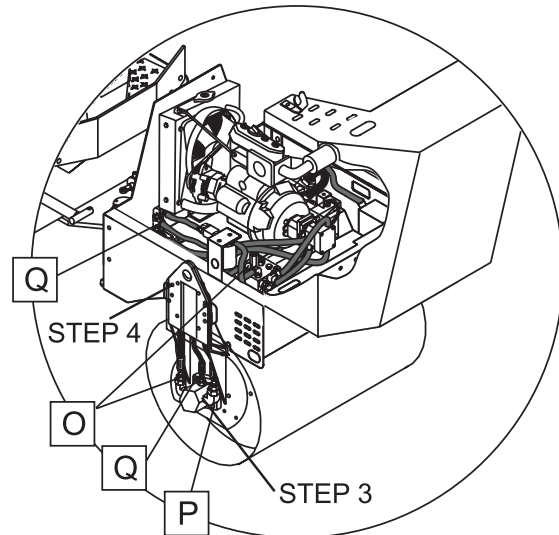

3. MARK AND DISCONNECT HOSES FROM MOTOR AND MANIFOLD.
4. REMOVE FOUR ALLEN HEAD SCREWS FROM DRUM SUPPORT PLATES.(SCREWS MAY NEED TO BE HEATED TO REMOVE)

5. REMOVE NUTS SECURING FLANGE ASSEMBLY TO DRUM SUPPORT PLATE AND PULL OFF OF FLANGE ASSEMBLY.
6. REMOVE THE SIX 9/16 BOLTS SECURING EXCITER PLATE TO DRUM WALL

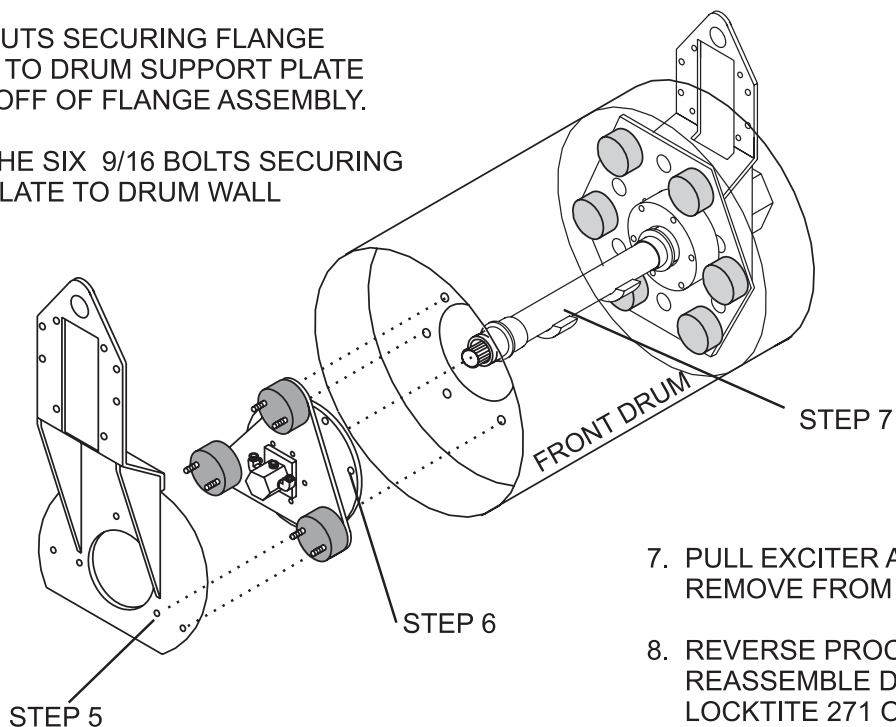

7. PULL EXCITER ASSEMBLY TO REMOVE FROM DRUM INTERIOR.
8. REVERSE PROCEDURES TO REASSEMBLE DRUM. USE LOCKTITE 271 ON ALL BOLTS AND NUTS.

Figure 37. Front-Right Drum Removal

# AR-13D RIDE-ON ROLLER — MAINTENANCE

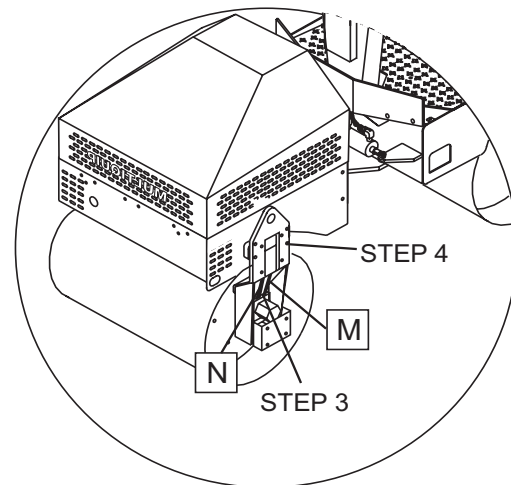
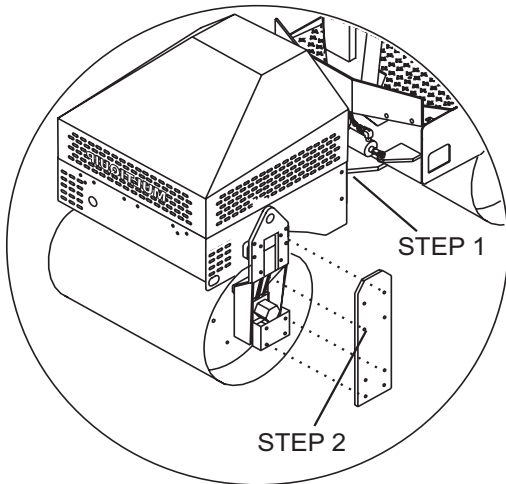

1. JACK FRAME UP SLIGHTLY AT ARTICULATION JOINT.

2. REMOVE THE EIGHT ALLEN HEAD SCREWS HOLDING THE SIDE COVER OF THE DRUM SUPPORT PLATE.

3. MARK AND DISCONNECT HOSES FROM MOTOR.

4. REMOVE FOUR ALLEN HEAD SCREWS FROM DRUM SUPPORT PLATE. (SCREWS MAY NEED TO BE HEATED TO REMOVE)

5. PULL DRUM SUPPORT PLATE OFF DRIVE PLATE ASSEMBLY.

6. REMOVE FOUR ALLEN HEAD SCREWS SECURING MOTOR TO DRUM SUPPORT PLATE AND SET ASIDE.

7. REMOVE SIX NUTS SECURING DRIVE PLATE TO SHOCK MOUNTS. PULL OFF DRIVE PLATE AND SET ASIDE.

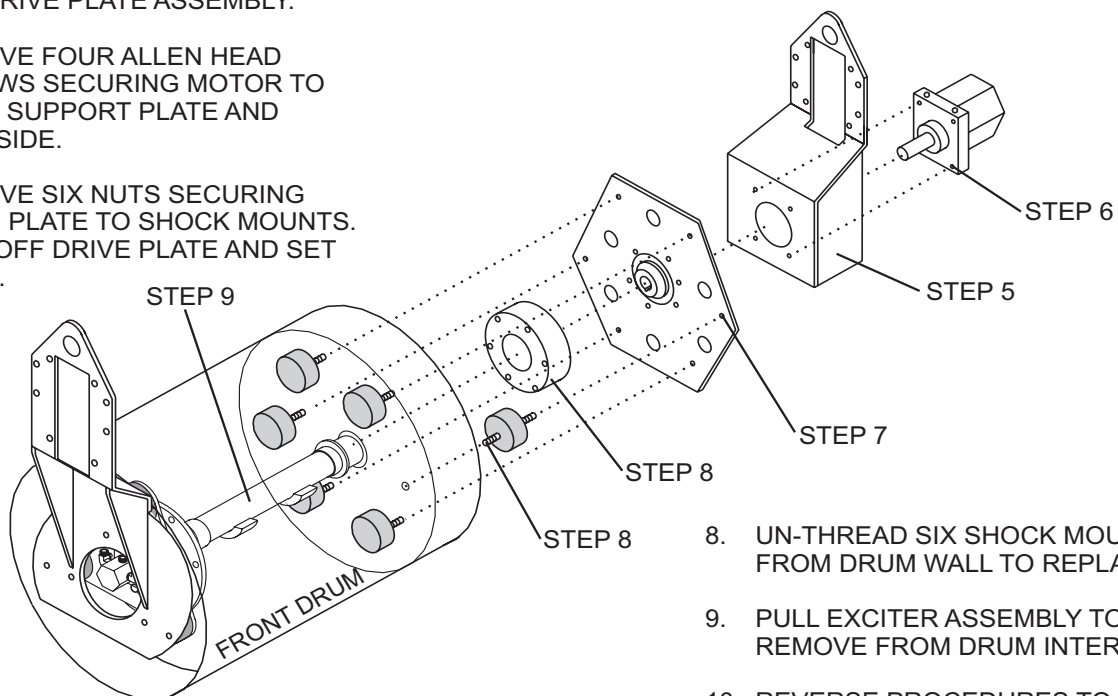

8. UN-THREAD SIX SHOCK MOUNTS FROM DRUM WALL TO REPLACE.

9. PULL EXCITER ASSEMBLY TO REMOVE FROM DRUM INTERIOR.

10. REVERSE PROCEDURES TO REASSEMBLE DRUM. USE LOCKTITE ON ALL NUTS AND BOLTS.

Figure 38. Front-Left Drum Removal

# AR-13D RIDE-ON ROLLER — MAINTENANCE

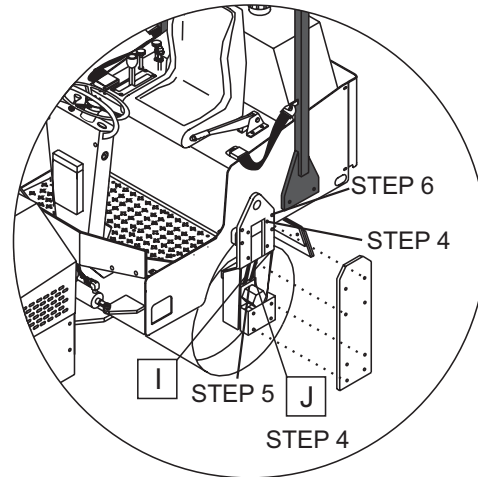
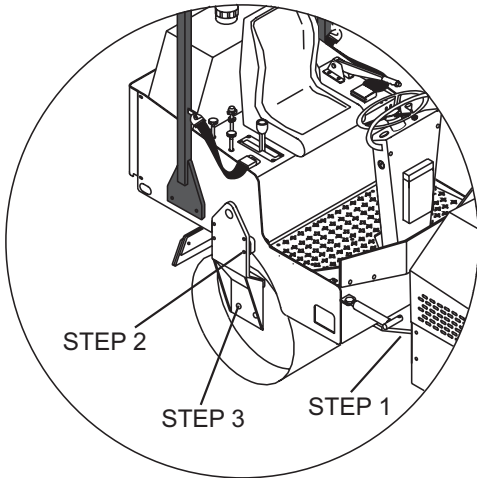

1. JACK FRAME UP SLIGHTLY AT ARTICULATION JOINT.
2. REMOVE THE FOUR ALLEN HEAD SCREWS SECURING THE DRUM SUPPORT PLATE TO THE FRAME.
3. REMOVE NUTS SECURING BEARING FLANGE TO BASE OF DRUM SUPPORT PLATE.
7. REMOVE TWO NUTS SECURING DRUM SUPPORT PLATE TO FLANGE. PULL OFF LEFT DRUM SUPPORT PLATE AND SET ASIDE.
8. PULL FLANGE OFF DRUM ROD FOR SERVICE.
9. PULL RIGHT DRUM SUPPORT PLATE OFF DRIVE PLATE ASSEMBLY.

4. REMOVE ALLEN HEAD SCREWS HOLDING THE SIDE COVER OF THE DRUM SUPPORT PLATE.
5. MARK AND DISCONNECT HOSES FROM MOTOR.
6. REMOVE FOUR ALLEN HEAD SCREWS FROM DRUM SUPPORT PLATES.

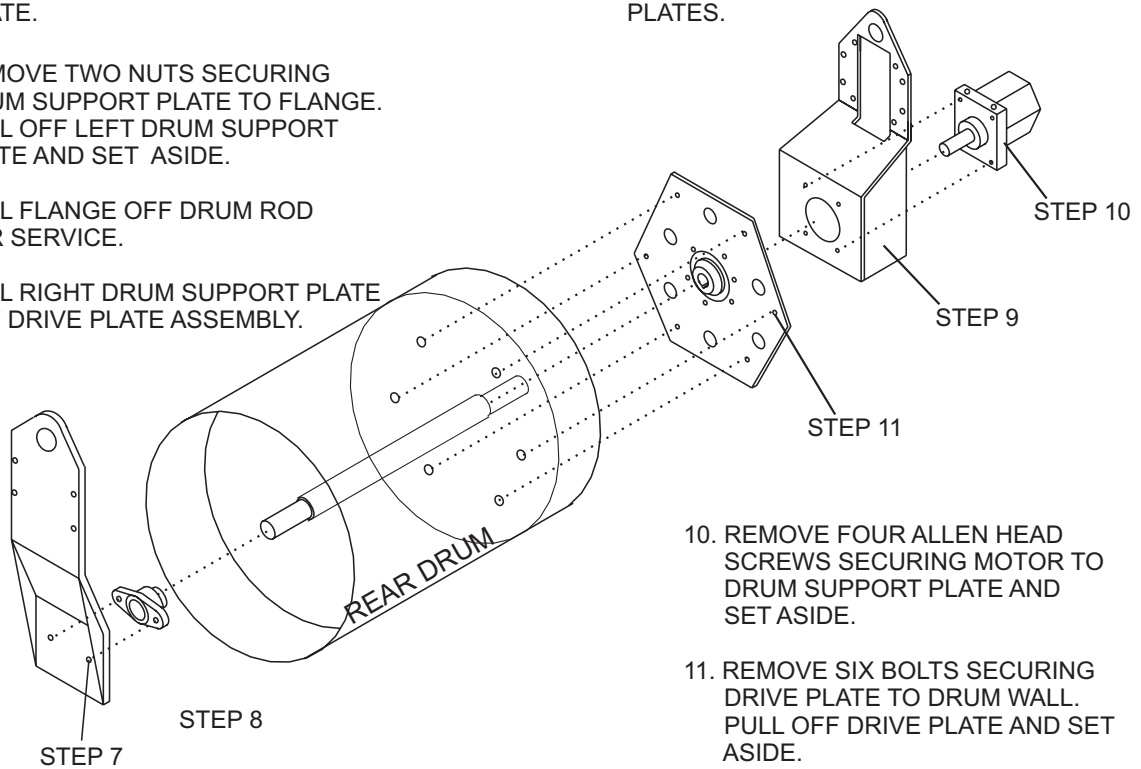

10. REMOVE FOUR ALLEN HEAD SCREWS SECURING MOTOR TO DRUM SUPPORT PLATE AND SET ASIDE.
11. REMOVE SIX BOLTS SECURING DRIVE PLATE TO DRUM WALL. PULL OFF DRIVE PLATE AND SET ASIDE.
12. REVERSE PROCEDURES TO REASSEMBLE DRUM.

Figure 39. Rear Drum Removal/Installation

# AR-13D RIDE-ON ROLLER — MAINTENANCE

## Alternator/Regulator

The AR-13D is equipped with a 40 amp charging system. This system uses three charge coils connected in parallel. The windings of each coil are wound with heavy-duty insulated wire and are further protected by insulating material for long life. A voltage regulator is provided to control the amount of charge voltage being delivered to the 12 volt electrical system. For servicing this charging system, contact your engine dealer.

## Neutral Safety Switch

The *travel lever* is provided with a *neutral safety switch* (Figure 40) that prevents the engine from starting when the lever is in the forward or reverse drive position. Lever must be placed in the neutral position in order for the starter to function.

To check this switch, remove the panel located below and to the rear of the floor. This switch is mounted to the lower forward/reverse lever mechanism. Disconnect the *white* and *green* wires. Place the lever in neutral and test for continuity. Place the lever in forward or reverse; no continuity should be present. Repair or replace as required.

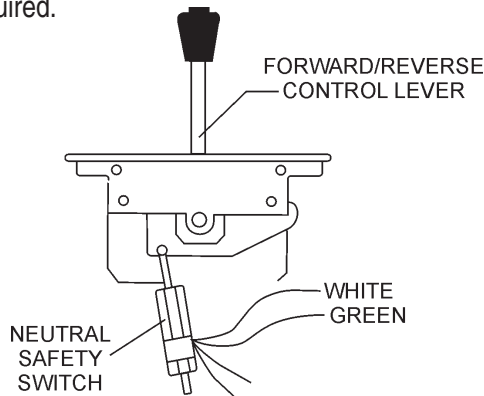

Figure 40. Safety Switch

## Vibrator Solenoid

The vibrator solenoid (Figure 41) is located in the manifold valve block and is controlled by the vibration switch located on top of the travel lever. This solenoid controls the vibration control valve which supplies hydraulic oil to the vibration drive motor.

To test the vibration solenoid, turn the ignition switch on. Check for proper supply voltage and ground. If proper voltage and ground are present, check the solenoid for continuity. If no continuity, replace the solenoid coil. If continuity is present, place your hand on the solenoid and turn the switch to the **ON** position; movement should be felt. **DO NOT START THE ENGINE FOR THIS TEST**

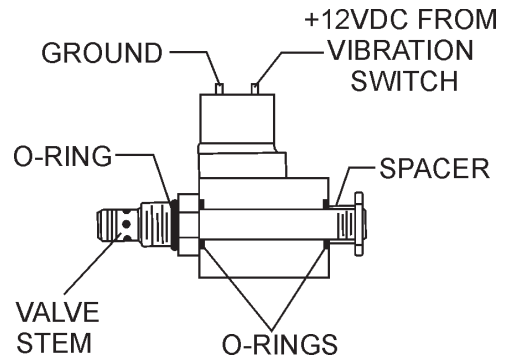

Figure 41. Vibration Solenoid

## Battery

Mishandling of the battery shortens the service life of the battery and adds to maintenance cost. When handling the battery do the following:

- Be careful not to let the battery electrolyte come in contact with your body or clothing.
- Always wear eye protection and rubber gloves, since the battery contains sulfuric acid which burns skin and eats through clothing.

**! CAUTION - BATTERY ACID BURN HAZARD**

If your clothing or skin comes in contact with the battery acid, **immediately** wash off with running water and get medical attention.

- Check the battery regularly and make sure that each electrolyte level is to the bottom of the vent well (Figure 42). If necessary add only distilled water in a well-ventilated area.

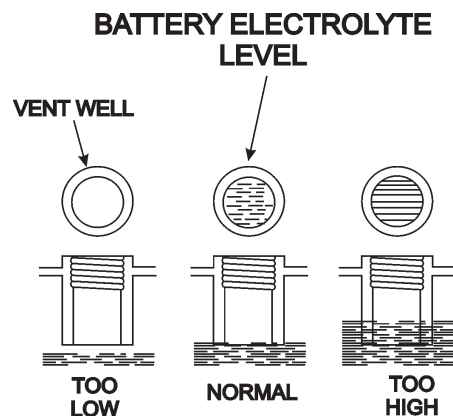

Figure 42. Battery Fluid Levels

# AR-13D RIDE-ON ROLLER — PREPARATION FOR LONG-TERM STORAGE

## Roller Storage

For storage of the roller for over 30 days, the following is recommended:

- Drain the fuel tank completely, or add STA-BIL to the fuel.
- Run the engine until the fuel in the injection system is completely consumed.
- Completely drain used oil from the engine crankcase and fill with fresh clean oil, then follow the procedures described in the engine manual for engine storage.
- Drain water tank
- Clean the entire roller and engine compartment.
- Remove battery and store it in cool dry place.
- Cover the roller and place it a clean dry area, that is protected from harsh elements.
- Remove ignition key, and store in a safe place.

# AR-13D RIDE-ON ROLLER — MANIFOLD TEST PORTS

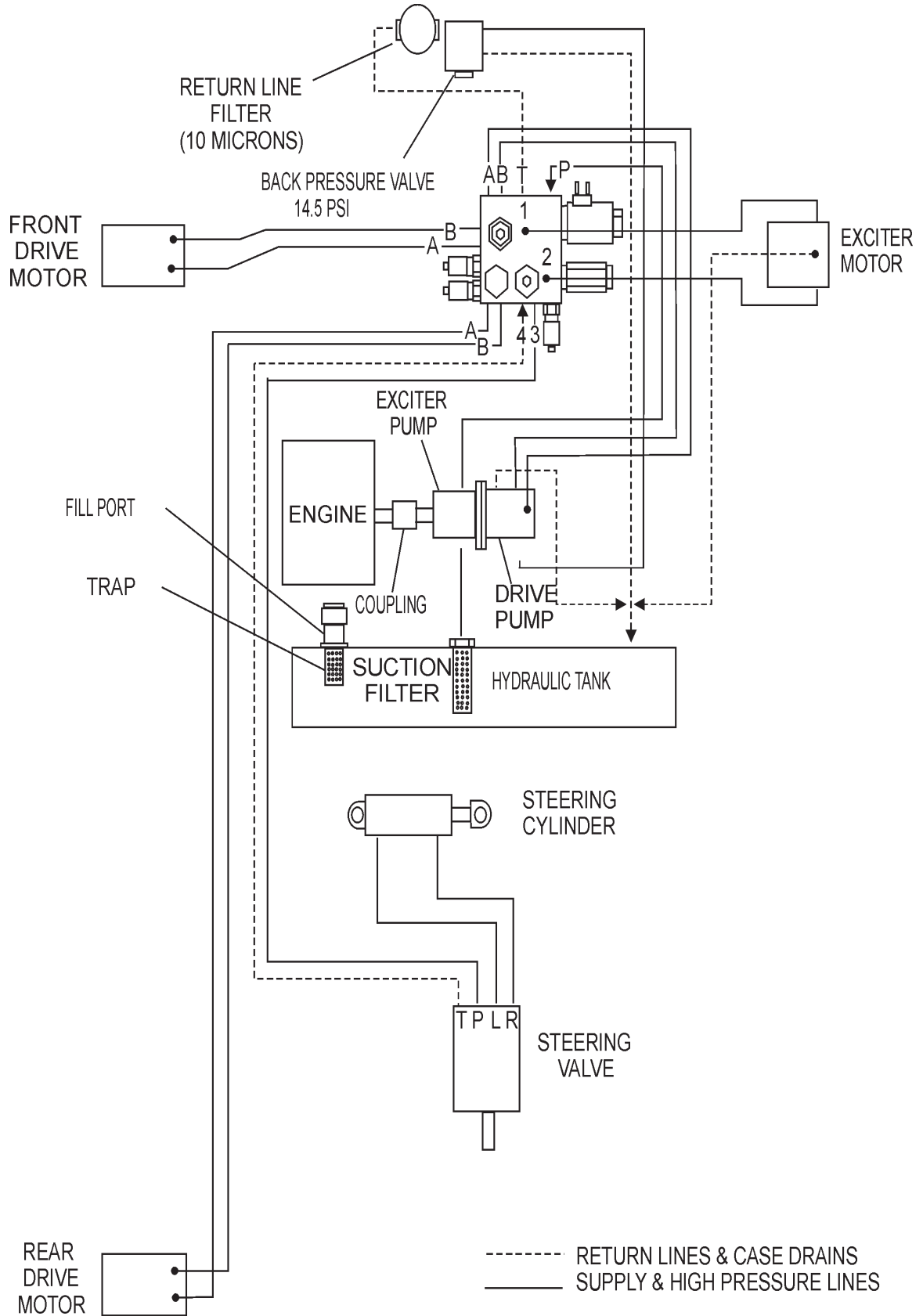

Figure 29. Manifold Test Ports

# AR-13D RIDE-ON ROLLER — HYDRAULIC SYSTEM DIAGRAM

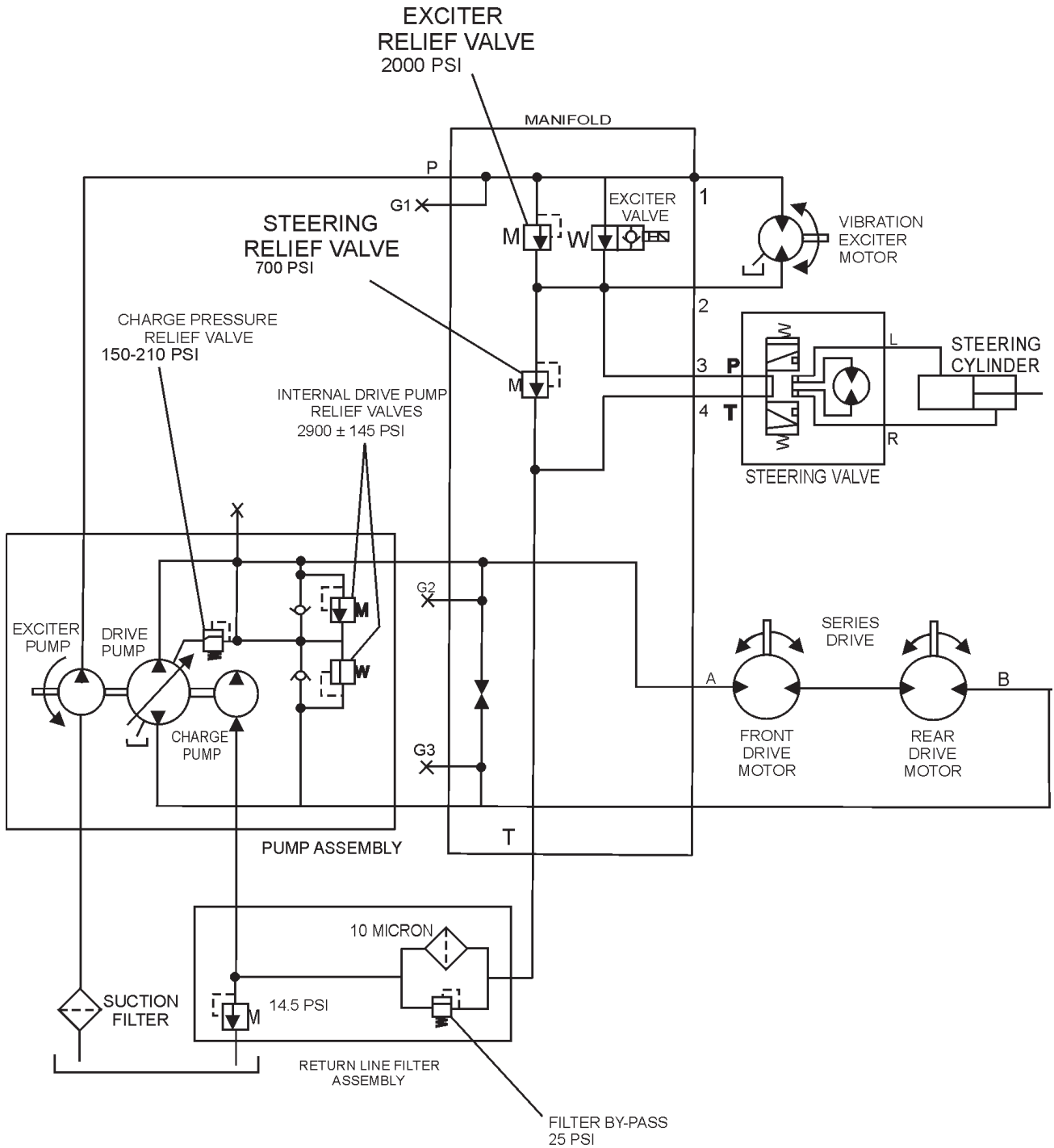
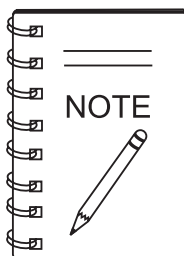

Figure 30. Hydraulic System Diagram



Wiring diagram not available at this time.



# AR-13D RIDE-ON ROLLER — HYDRAULIC HOSE CONNECTIONS

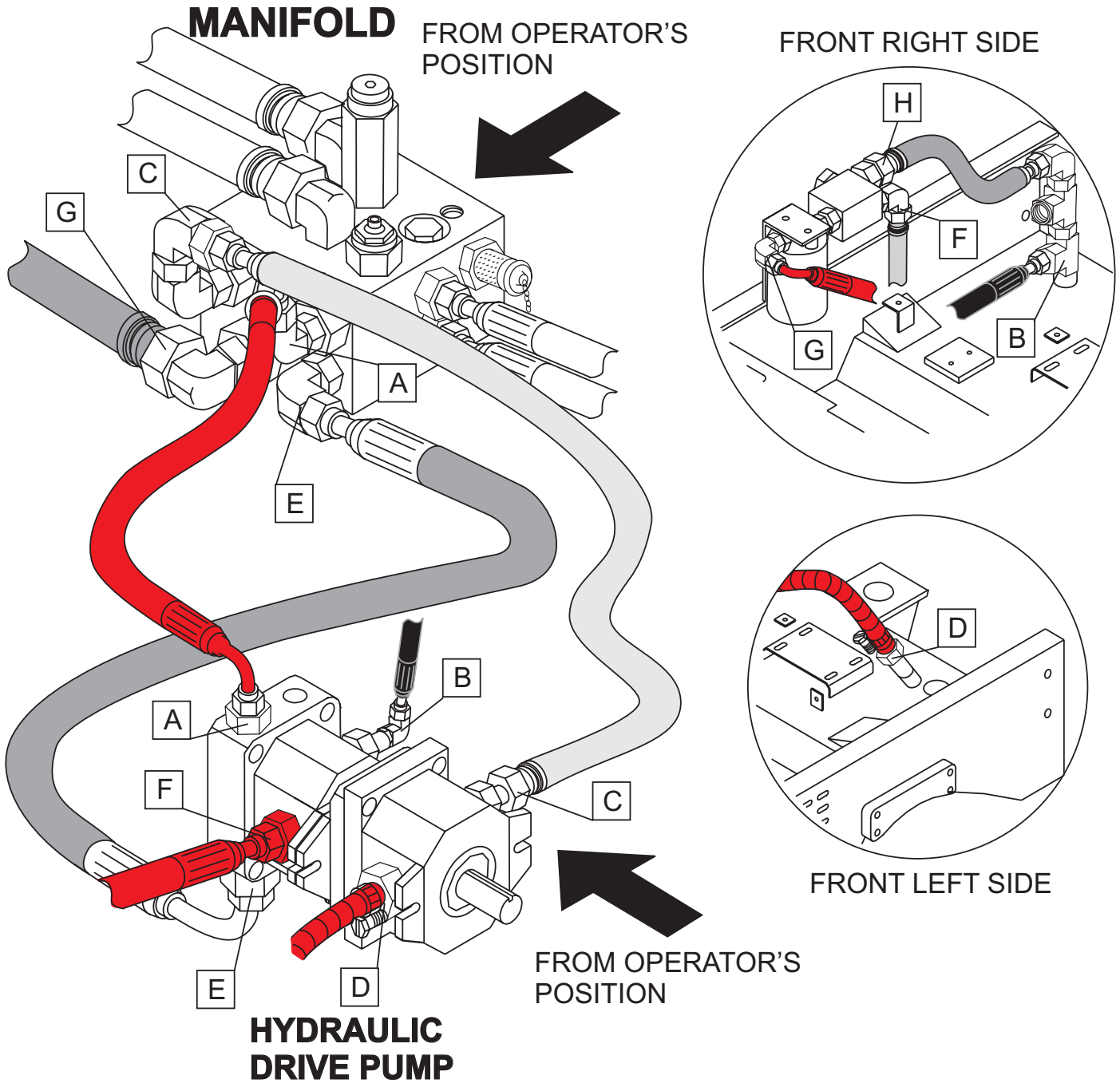

## NOTES

HOSES SHADED FOR VISUAL CLARITY.

Figure 32. Hydraulic Hose Connections 1

# AR-13D RIDE-ON ROLLER — HYDRAULIC HOSE CONNECTIONS

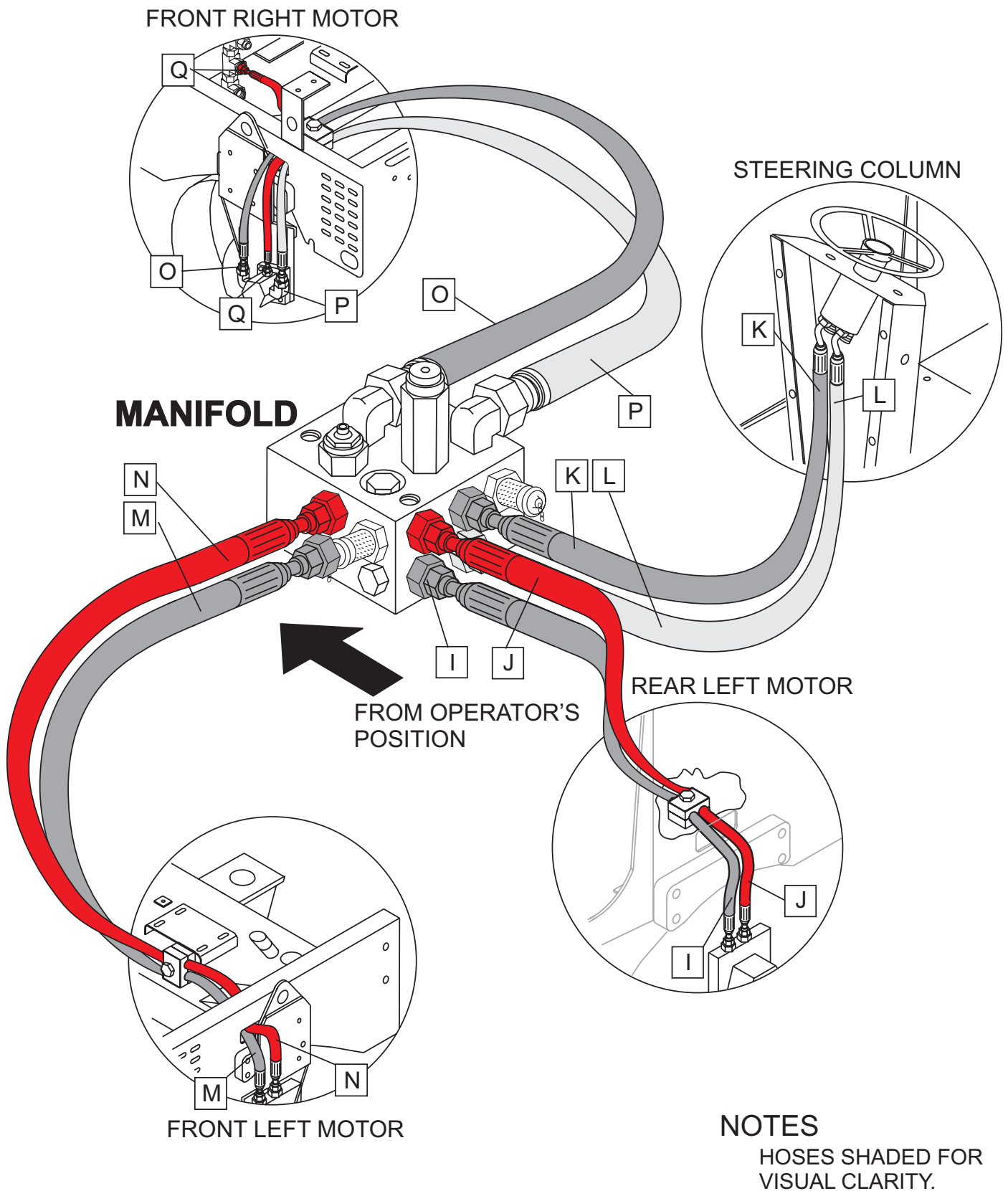

Figure 33. Hydraulic Hose Connections 2

# AR-13D RIDE-ON ROLLER — TROUBLESHOOTING (ROLLER)

TABLE 6. ROLLER TROUBLESHOOTING

SYMPTOM	POSSIBLE PROBLEM	SOLUTION
Low Vibration	Low engine RPM?	Check and adjust engine speed.
	Low hydraulic pressure?	Check and adjust hydraulic pressure.
No Vibration	No voltage to 12 volt solenoid?	Check vibration switch, check coil for continuity.
	No oil pressure?	Check for proper oil pressure or defective relief valve.
	Broken motor coupler?	Replace coupler.
Slow Steering	Low hydraulic pressure?	Check pressure.
	Steering column connector?	Inspect bearings and grease if necessary.
	Defective steering cylinder?	Check seals, replace if necessary.
Steers Slow in One Direction	Defective Steering cylinder?	Inspect cylinder for contamination, replace if necessary.
Slow Forward/Reverse Speed	Low hydraulic pressure?	Check pressure.
	Rubber scrapper adjustment incorrect?	Check for proper adjustment against drum.
	Rubber shock mount loose?	Inspect for broken mount, replace if necessary.
	Free wheel valve " <i>open</i> "?	Close valve.
	Speed control cable out of adjustment?	Inspect cable and adjust if necessary.
Main Hydraulic Pressure Low	Incorrect engine speed?	Adjust engine speed to correct speed.
	Broken rubber shock mounts or drive plate?	Inspect for cracks, replace if necessary.
	Drive motor hardware not secure?	Check motor nut and key coupler.

# AR-13D RIDE-ON ROLLER — TROUBLESHOOTING (ENGINE)

**TABLE 7. ENGINE TROUBLESHOOTING**

<b>SYMPTON</b>	<b>POSSIBLE PROBLEM</b>	<b>SOLUTION</b>
Engine will not start or start is delayed, although engine can be turned over.	No Fuel reaching injection pump?	Add fuel. Check entire fuel system.
	Defective fuel pump?	Replace fuel pump.
	Fuel filter clogged?	Replace fuel filter and clean tank.
	Faulty fuel supply line?	Replace or repair fuel line.
	Compression too low?	Check piston, cylinder and valves. Adjust or repair per engine repair manual.
	Fuel pump not working correctly?	Repair or replace fuel pump.
	Oil pressure too low?	Check engine oil pressure.
	Low starting temperature limit exceeded	Comply with cold starting instructions and proper oil viscosity.
	Defective battery?	Charge or replace battery.
At low temperatures engine will not start.	Engine oil too thick?	Refill engine crankcase with correct type of oil for winter environment.
	Defective battery?	Replace battery.
Engine fires but stops soon as starter is switched off.	Fuel filter blocked?	Replace fuel filter.
	Fuel supply blocked?	Check the entire fuel system.
	Defective fuel pump?	Replace fuel pump.
Engine stops by itself during normal operation.	Fuel tank empty?	Add fuel.
	Fuel filter blocked?	Replace fuel filter.
	Defective fuel pump?	Replace fuel pump.
	Mechanical oil pressure shutdown sensor stops the engine due to low oil?	Add oil. Replace low oil shutdown sensor if necessary.

# AR-13D RIDE-ON ROLLER — TROUBLESHOOTING (ENGINE)

**TABLE 7. ENGINE TROUBLESHOOTING (CONTINUED)**

SYMPTON	POSSIBLE PROBLEM	SOLUTION
Low engine power, output and speed.	Fuel tank empty?	Replace fuel filter.
	Fuel filter clogged?	Replace fuel filter.
	Fuel tank venting is inadequate?	Ensure that tank is adequately vented.
	Leaks at pipe unions?	Check threaded pipe unions tape and tighten unions as required.
	Speed control lever does not remain in selected position?	See engine manual for corrective action.
	Engine oil level too full?	Correct engine oil level?
Low engine power output and low speed, black exhaust smoke.	Air filter blocked?	Clean or replace air filter.
	Incorrect valve clearances?	Adjust valves per engine specification.
	Malfunction at injector?	See engine manual.
Air-cooled diesel engine runs very "HOT". Cylinder head overheats.	Too much oil in engine crankcase?	Drain off engine oil down to uppermark on dipstick.
	Entire cooling air system contaminated blocked?	Clean cooling air system, and cooling fin areas.



# EXPLANATION OF CODE IN REMARKS COLUMN

The following section explains the different symbols and remarks used in the Parts section of this manual. Use the help numbers found on the back page of the manual if there are any questions.

The contents and part numbers listed in the parts section are subject to change **without notice**. Multiquip does not guarantee the availability of the parts listed.

Sample Parts List:

NO.	PART NO.	PART NAME	QTY.	REMARKS
1	12345	BOLT .....	1	INCLUDES ITEMS W/*
2*		WASHER, 1/4 IN. ....		NOT SOLD SEPARATELY
2*	12347	WASHER, 3/8 IN. ...	1	MQ-45T ONLY
3	12348	HOSE .....	A/R	MAKE LOCALLY
4	12349	BEARING .....	1	S/N 2345B AND ABOVE

## NO. Column

**Unique Symbols** - All items with same unique symbol (\*, #, +, %, or >) in the number column belong to the same assembly or kit, which is indicated by a note in the "Remarks" column.

**Duplicate Item Numbers** - Duplicate numbers indicate multiple part numbers are in effect for the same general item, such as different size saw blade guards in use or a part that has been updated on newer versions of the same machine.



When ordering a part that has more than one item number listed, check the remarks column for help in determining the proper part to order.

## PART NO. Column

**Numbers Used** - Part numbers can be indicated by a number, a blank entry, or TBD.

TBD (To Be Determined) is generally used to show a part that has not been assigned a formal part number at time of publication.

A blank entry generally indicates that the item is not sold separately or is not sold by Multiquip. Other entries will be clarified in the "Remarks" Column.

## QTY. Column

**Numbers Used** - Item quantity can be indicated by a number, a blank entry, or A/R.

A/R (As Required) is generally used for hoses or other parts that are sold in bulk and cut to length.

A blank entry generally indicates that the item is not sold separately. Other entries will be clarified in the "Remarks" Column.

## REMARKS Column

Some of the most common notes found in the "Remarks" Column are listed below. Other additional notes needed to describe the item can also be shown.

**Assembly/Kit** - All items on the parts list with the same unique symbol will be included when this item is purchased.

Indicated by:

"INCLUDES ITEMS W/(unique symbol)"

**Serial Number Break** - Used to list an effective serial number range where a particular part is used.

Indicated by:

"S/N XXXXX AND BELOW"

"S/N XXXX AND ABOVE"

"S/N XXXX TO S/N XXX"

**Specific Model Number Use** - Indicates that the part is used only with the specific model number or model number variant listed. It can also be used to show a part is NOT used on a specific model or model number variant.

Indicated by:

"XXXXX ONLY"

"NOT USED ON XXXX"

**"Make/Obtain Locally"** - Indicates that the part can be purchased at any hardware shop or made out of available items. Examples include battery cables, shims, and certain washers and nuts.

**"Not Sold Separately"** - Indicates that an item cannot be purchased as a separate item and is either part of an assembly/kit that can be purchased, or is not available for sale through Multiquip.

## AR-13D RIDE-ON ROLLER — SUGGESTED SPARE PARTS

### AR-13D Ride-on Tandem Drum Roller w/Briggs and Stratton Diesel Engine *1 to 3 Units*

<u>Qty.</u>	<u>P/N</u>	<u>Description</u>
1 .....	513324 .....	Forward Reverse Travel Cable
.....	509350SW .....	Neutral Safety Switch
2 .....	510229 .....	Throttle Cable
6 .....	508667 .....	Hydraulic Oil Filter
1 .....	507278 .....	Hydraulic Tank Cap
6 .....	820311 .....	Fuel Filter
1 .....	34507 .....	Fuel Tank Cap Gauge
1 .....	509249 .....	Water Tank Cap
4 .....	508433 .....	Rubber Drum Scraper
3 .....	M113621 .....	Air Filter Element
4 .....	691959 .....	Ignition Key
2 .....	692318 .....	Ignition Switch
4 .....	821075 .....	Fan Belt
4 .....	820150 .....	Rocker Cover Gasket
6 .....	820314 .....	Engine Oil Filter
2 .....	820258 .....	Radiator Cap
1 .....	825222 .....	Starter
2 .....	821135 .....	Oil Pressure Switch
2 .....	820208 .....	Water Temperature Switch
2 .....	825064 .....	Thermostat
2 .....	515848 .....	Breaker Switch
1 .....	825324 .....	Injection Pump
1 .....	825265 .....	Water Pump
1 .....	825133 .....	Radiator Hose Upper
1 .....	825134 .....	Radiator Hose Lower

# AR-13D RIDE-ON ROLLER — NAME PLATE AND DECALS

## NAME PLATE AND DECALS

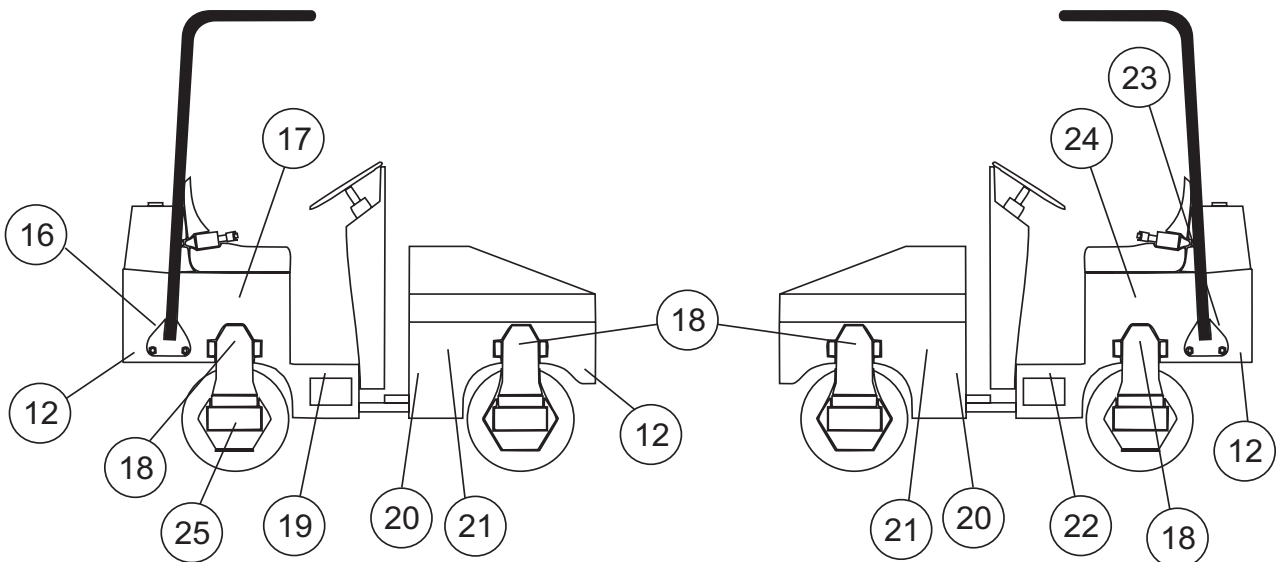
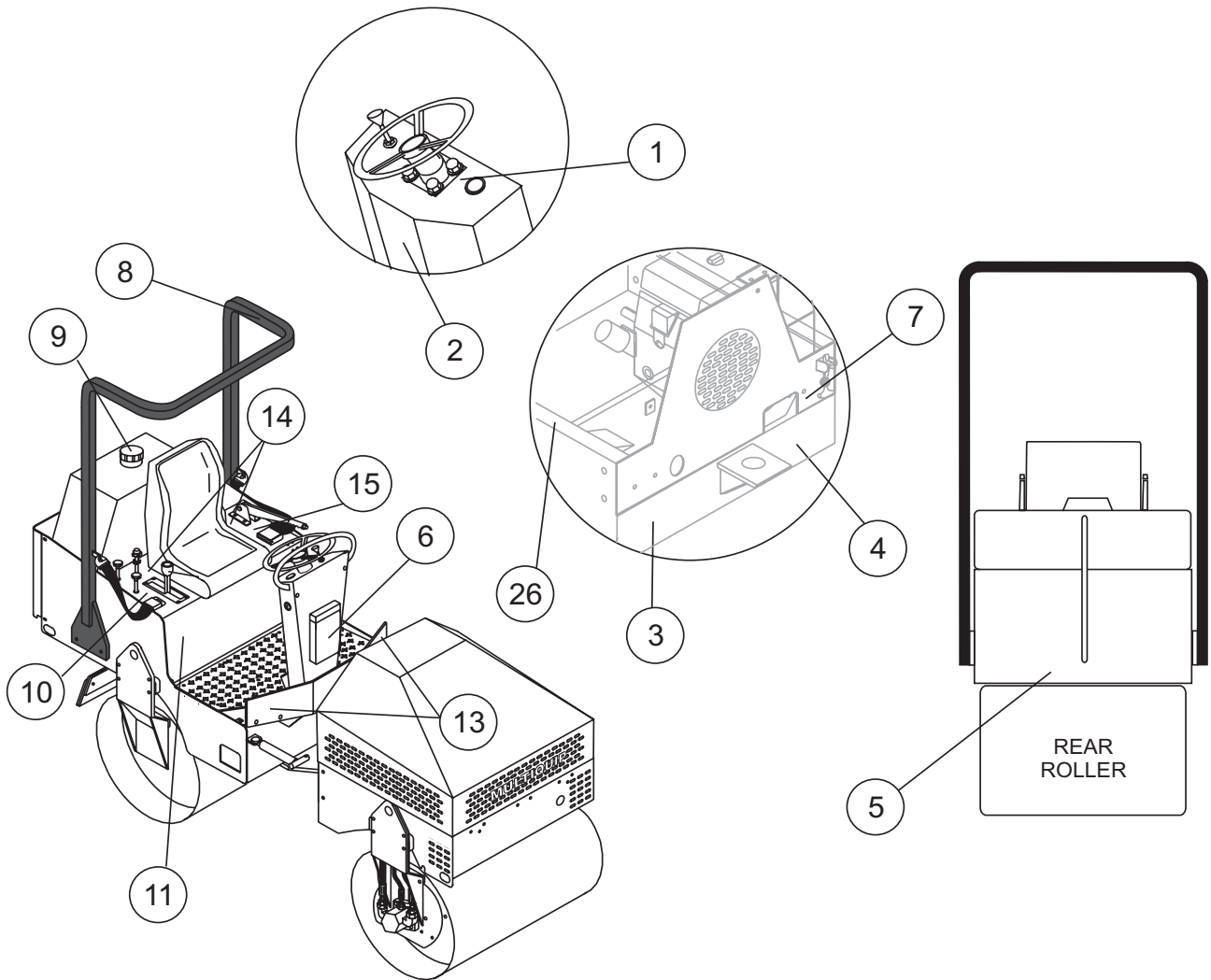

## AR-13D RIDE-ON ROLLER — NAME PLATE AND DECALS

### NAME PLATE AND DECALS

<u>NO.</u>	<u>PART NO.</u>	<u>PART NAME</u>	<u>QTY.</u>	<u>REMARKS</u>
1	513457	DECAL: STEERING CONSOLE	1	
2	13118	DECAL: POWDER COATED	1	
3	511726	DECAL: HYDRAULIC OIL LEVEL INDICATOR	1	
4	511736	DECAL: WARNING	1	
5	511740	DECAL: MULTIQUIP BANNER	1	
6	34536	DECAL: OWNERS MANUAL	1	
7	513580	DECAL: ENGINE RPM SETTING	1	
9	513698	DECAL: WATER TANK CAP	1	
10	515436	DECAL: CONTROL PANEL	1	
11	511737	DECAL: SERVICE INSTRUCTION CHART	1	
12	513393	DECAL: SECURING POINT INDICATOR .....	3	POINT ARROW DOWN
13	511735	DECAL: CAUTION	2	
14	513707	DECAL: ATTENTION	2	
15	513467	DECAL: PARKING BRAKE INSTRUCTIONS	1	
16	515818	DECAL: AR-13D MQ LOGO	1	
17	511738	DECAL: DANGER	1	
18	513393	DECAL: SECURING POINT INDICATOR .....	4	POINT ARROW UP
19	513469	DECAL: CAUTION STRIPE PATTERN .....	1	HORIZONTAL PLACEMENT
20	511718	DECAL: CAUTION STRIPE PATTERN .....	2	VERTICAL PLACEMENT
21	513688	DECAL: MQ LOGO	2	
22	513740	DECAL: CAUTION STRIPE PATTERN .....	1	HORIZONTAL PLACEMENT
23	515815	DECAL: AR-13D MQ LOGO	1	
24	511739	DECAL: CAUTION: INSTRUCTIONS	1	
25	511724	DECAL: GREASE REMINDER	1	
26	511733	DECAL: HYDRAULIC OIL INDICATOR	1	

# AR-13D RIDE-ON ROLLER — FRONT DRUM ASSY.

FRONT DRUM ASSY.

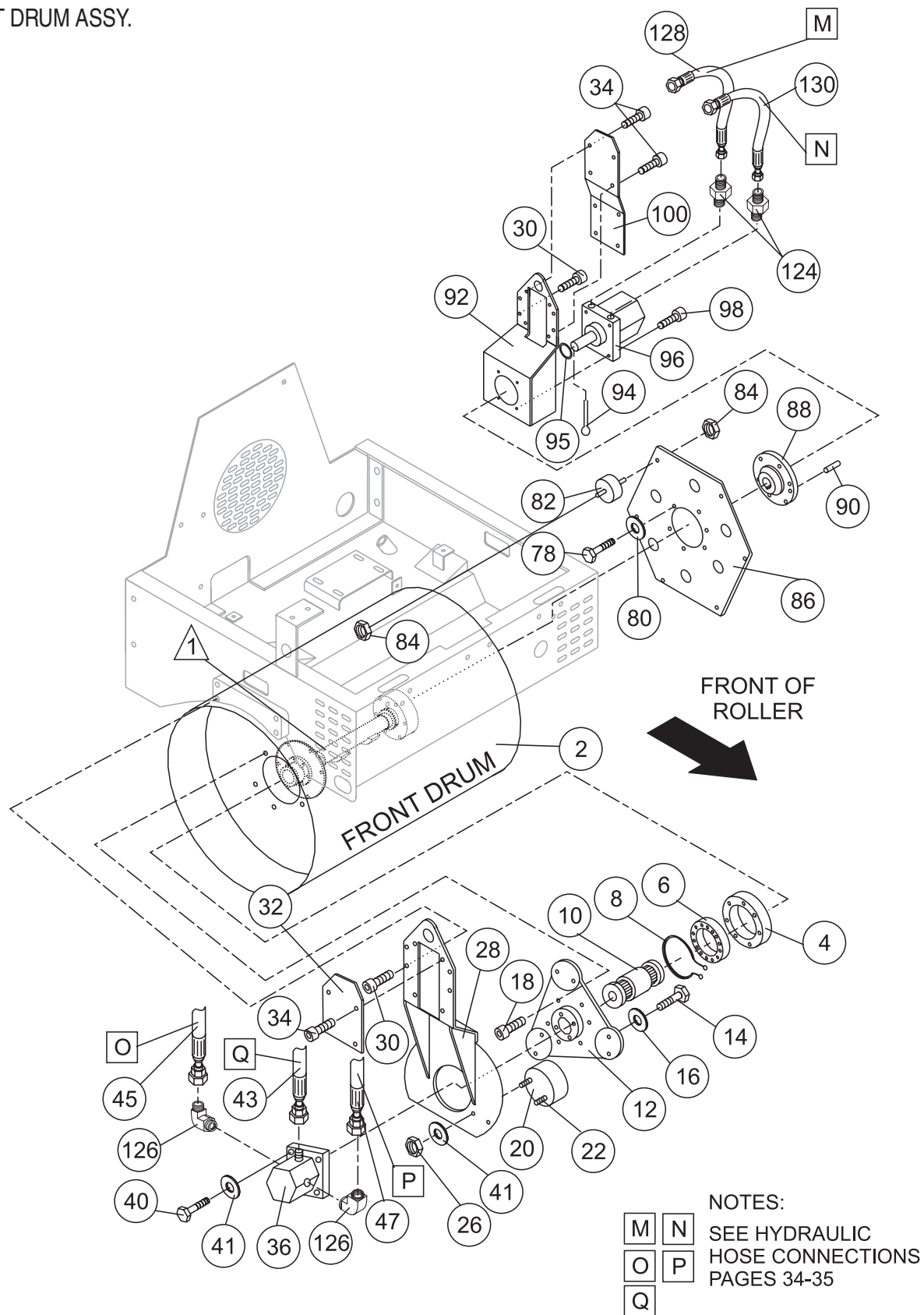

NOTES:

- |   |   |  |
|---|---|--|
| M | N | SEE HYDRAULIC HOSE CONNECTIONS PAGES 34-35 |
| O | P |  |
| Q |   |  |

1 EXCITER ASSEMBLY SEE PAGE 54

# AR-13D RIDE-ON ROLLER — FRONT DRUM ASSY.

## FRONT DRUM ASSY.

<u>NO.</u>	<u>PART NO.</u>	<u>PART NAME</u>	<u>QTY.</u>	<u>REMARKS</u>
2	513280	FRONT ROLLER	1	
4	506145	HOUSING BEARING	1	
6	506147	BEARING	1	
8	506136	RING, RETAINING	1	
10	508665	COUPLER	1	
12	506142	MOUNT, VIBRATION MOTOR	1	
14	011208025	BOLT, 8X25T .....	6	REPLACES 508342
16	EM923023	WASHER, FLAT 5/16" .....	6	REPLACES 492597
18	492264	BOLT, 3/8"X1"	6	
20	506141	SHOCK, MOUNT	3	
22	508340	STUD, M8X40	6	
26	020108060	NUT, M8 .....	6	REPLACES 508341
28	514522	ROLLER, SUPPORT, RIGHT .....	1	LEFT SIDE - FRONT/REAR
30	6109210	BOLT 1/2"X1-1/2" .....	8	REPLACES 492276
32	513283	HOSE, PROTECTION COVER	1	
34	513314	NUT 1/4"X1/2"	12	
36	506220	MOTOR, HYDRAULIC	1	
40	492362	NUT 5/16"X5/8"	4	
41	EM923343	WASHER, LOCK 5/16" DIAMETER .....	10	REPLACES 492623
43	513337	HOSE	1	
45	513343	HOSE	1	
47	513342	HOSE	1	
78	EM963610	BOLT 3/8"X1" .....	6	REPLACES 492375
80	3019092	WASHER, 3/8" .....	6	REPLACES 508346
82	505985	SHOCK, MOUNT	6	
84	021110120	NUT, NYLON LOCK M10 ZINC 1.SP	12	
86	505977	PLATE, DRIVER	1	
88	505984	HUB	1	
90	EM503803	PINS, DOWEL .....	2	REPLACES 503803
92	515637	SUPPORT, ROLLER, LEFT .....	1	RIGHT SIDE - FRONT
94	EM924006	KEY, COTTER 1/8"X2" .....	1	REPLACES 491690
95	511159	FLAT WASHER	1	
96	515396	MOTOR, HYDRAULIC	1	
98	505990	BOLT 1/2"X2-1/2"	4	
100	515639	COVER	1	
124	505951	FITTING	2	
126	513332	FITTING	2	
128	515641	HOSE	1	
130	513344	HOSE	1	

# AR-13D RIDE-ON ROLLER — EXCITER ASSY.

EXCITER ASSY.

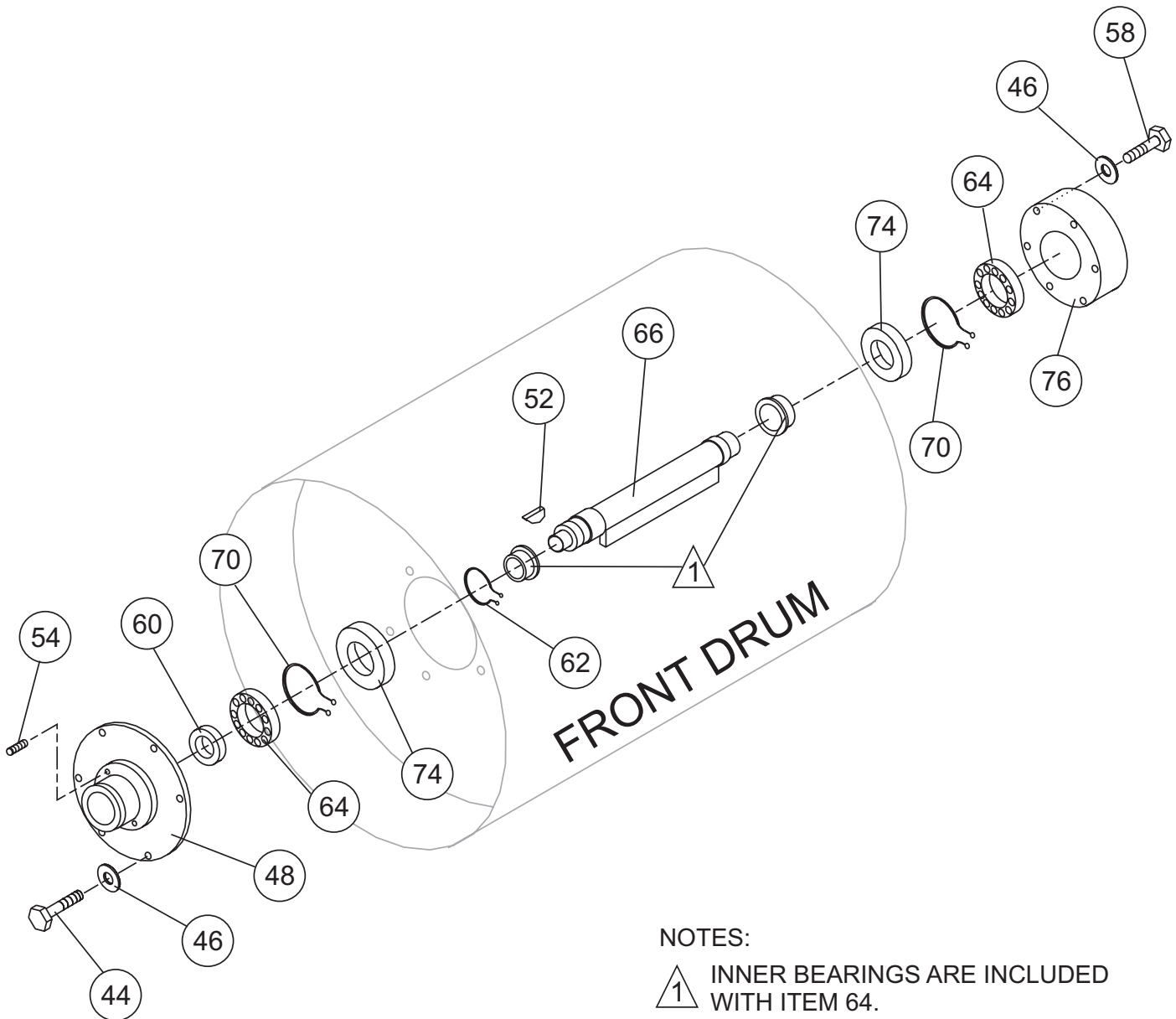

## AR-13D RIDE-ON ROLLER — EXCITER ASSY.

### EXCITER ASSY.

<u>NO.</u>	<u>PART NO.</u>	<u>PART NAME</u>	<u>QTY.</u>	<u>REMARKS</u>
44	EM963610	CAPSCREW, 3/8" N X 1-1/4" G5	6	
46	3019092	WASHER, 3/8" .....	12 .....	REPLACES 508346
48	513285	HOUSING, BEARING RIGHT	1	
52	EM927040	KEY, WOODRUFF 606 .....	1 .....	REPLACES 506250
54	492467	SCREW, ALLEN 5/16"	4	
58	EM963610	CAPSCREW, 3/8" .....	6 .....	REPLACES 492375
60	506144	SEAL	1	
62	490964	RING, RETAINING	1	
64	506131	BEARING	2	
66	513418	EXCITER SHAFT	1	
70	506135	RING, RETAINING	2	
74	513286	OIL SEAL 65x100x9	2	
76	513287	HOUSING, BEARING LEFT	1	

# AR-13D RIDE-ON ROLLER — REAR DRUM & CHASSIS ASSY.

REAR DRUM & CHASSIS ASSY.

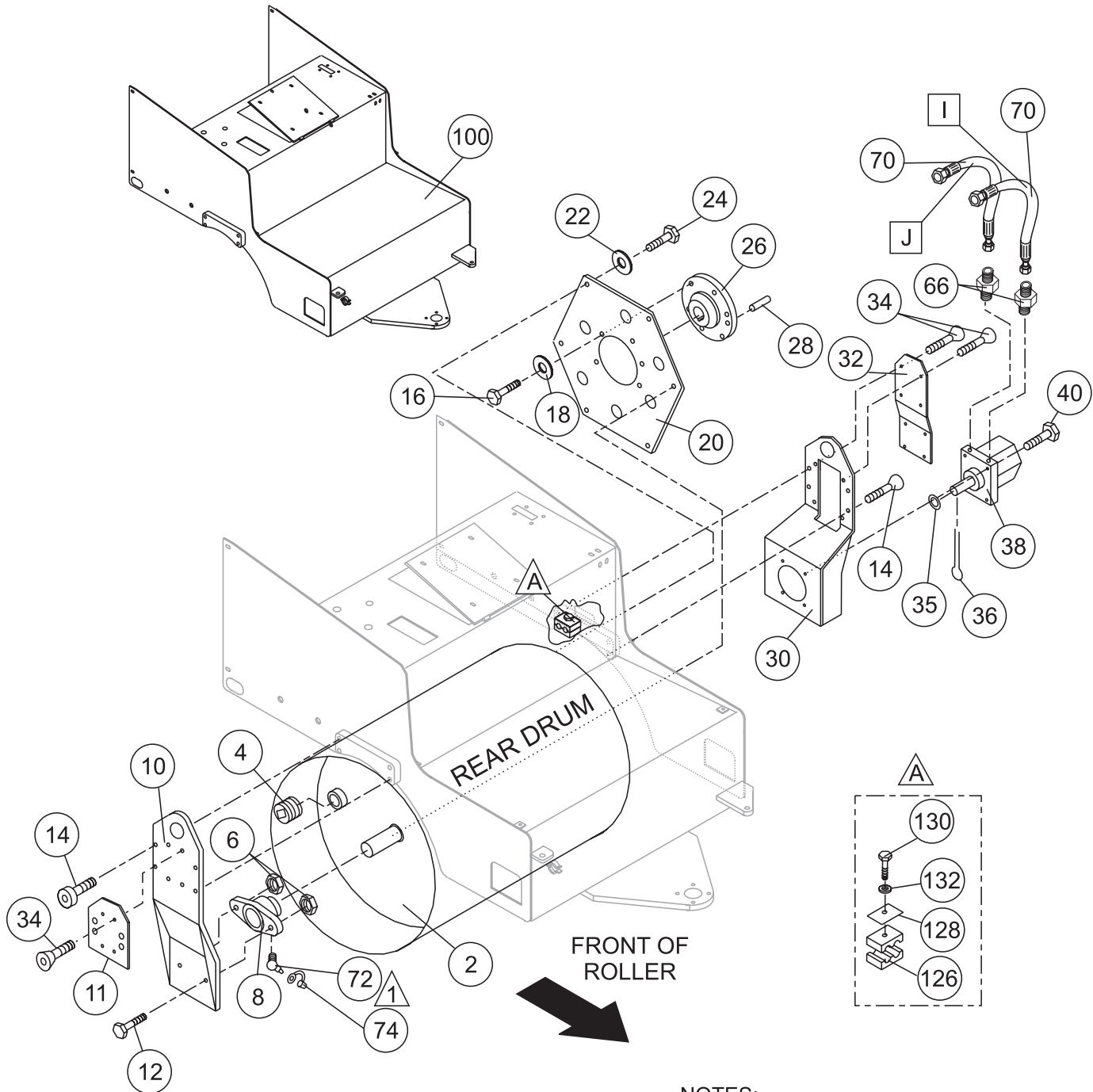

**NOTES:**



SEE HYDRAULIC HOSE CONNECTIONS PAGE 34-35



ITEMS 72 AND 74 ARE INCLUDED WITH ITEM 8 (BEARING, FLANGE) AND CANNOT BE SOLD SEPARATELY.

# AR-13D RIDE-ON ROLLER — REAR DRUM & CHASSIS ASSY.

## REAR DRUM & CHASSIS ASSY.

<u>NO.</u>	<u>PART NO.</u>	<u>PART NAME</u>	<u>QTY.</u>	<u>REMARKS</u>
2	513291	REAR DRUM	1	
4	505988	ALLEN PLUG	1	
6	492584	NUT, LOCK 1/2 IN.	2	
8	503735	BEARING, FLANGE .....	1 .....	INCLUDES ITEMS W/*
10	514523	SUPPORT, ROLLER .....	1 .....	RIGHT SIDE - REAR
11	513283	HOSE PROTECTION COVER	1	
12	509165	BOLT, 1/2 NC x 2-1/4 IN. G5	2	
14	6109210	BOLT, 1/2 NC x 1-1/2 IN. G5 .....	8 .....	REPLACES 492276
16	EM963610	CAPSCREW, 3/8 IN. NC x 1-1/4 IN. G5	6	
18	3019092	LOCK WASHER 3/8 IN. ....	6 .....	REPLACES 508346
20	505977	PLATE DRIVE	1	
22	3019092	WASHER 3/8 IN. ....	6 .....	REPLACES 508346
24	EM963610	CAPSCREW, 3/8 NC x 1-1/4 IN. G8 .....	6 .....	REPLACES 492375
26	505984	HUB	1	
28	EM503803	PINS, DOWEL 3/8 x 1 IN.	2	
30	515637	REAR ROLLER SUPPORT, LEFT .....	1 .....	LEFT SIDE - FRONT/REAR
32	515639	SUPPORT COVER	1	
34	513314	BOLT, 1/4 NC x 1/2 IN. G	12	
35	511159	FLAT WASHER 1 IN.	1	
36	EM924006	KEY, COTTER 1/8 x 2 IN. ....	1 .....	REPLACES 491690
38	515396	MOTOR, HYDRAULIC	1	
40	505990	BOLT, 1/2 NC x 2-1/2 IN. G	4	
66	505951	FITTING 8-10-F5OLO-S	2	
70	513349	HOSE	2	
72 *		ZERK GREASE FITTING .....	1 .....	CANNOT BE SOLD SEPARATELY
74 *		ZERK CAP .....	1 .....	CANNOT BE SOLD SEPARATELY
100	513266	REAR CHASSIS	1	
126	505976	CLAMP 3/4	5	
128	506185	PLATE CORNER	4	
130	492367	SCREW, HHC5/16"-18X1-3/4"	3	
132	EM923343	WASHER, LOCK 5/16" .....	4 .....	REPLACES 492623

# AR-13D RIDE-ON ROLLER — COVERS AND FRAME ARTICULATION LOCK ASSY.

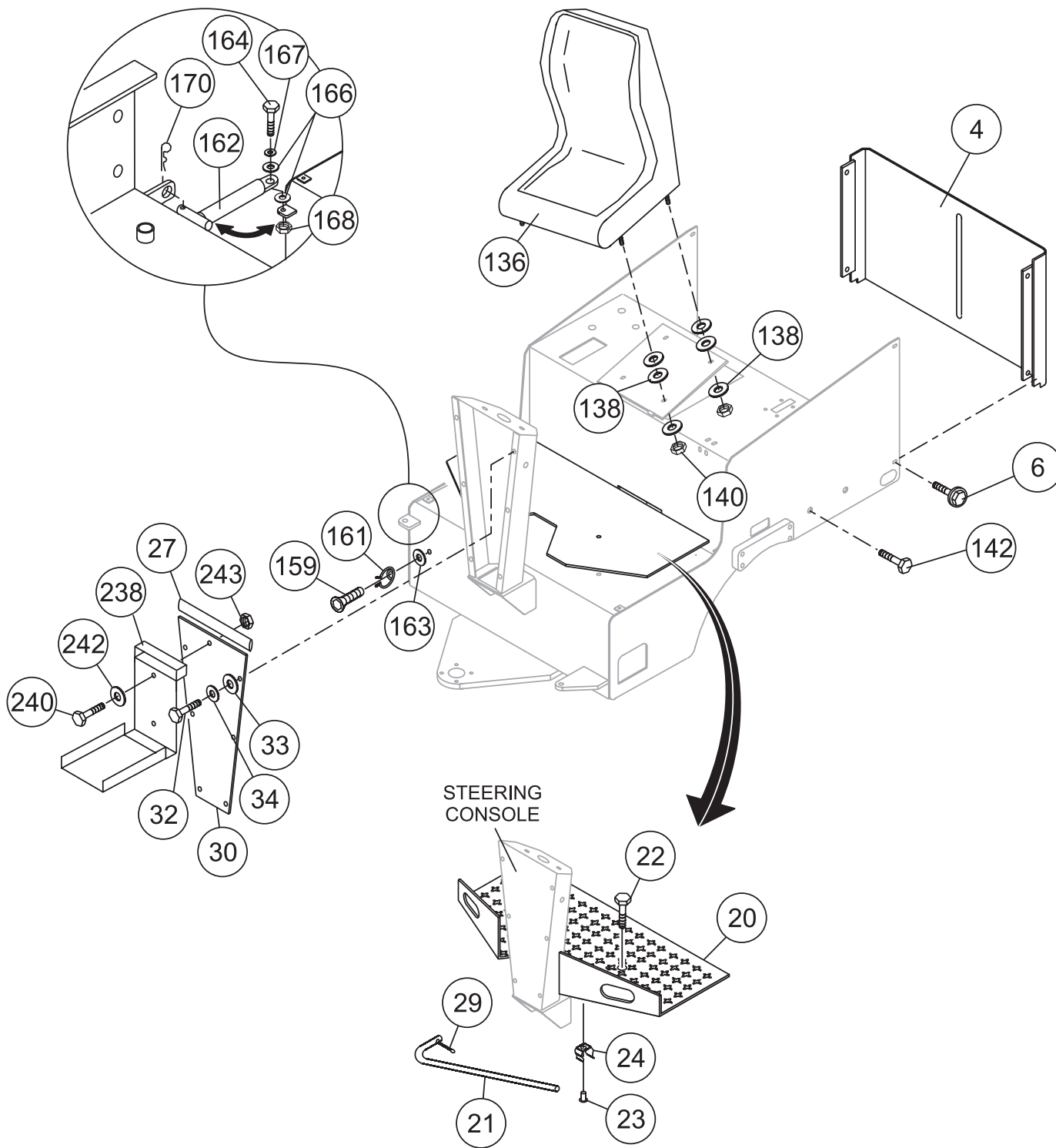

# AR-13D RIDE-ON ROLLER — COVERS AND FRAME ARTICULATION LOCK ASSY.

## COVERS AND FRAME ARTICULATION LOCK ASSY.

<u>NO.</u>	<u>PART NO.</u>	<u>PART NAME</u>	<u>QTY.</u>	<u>REMARKS</u>
4	513315	REAR WATER TANK COVER	1	
6	509177	BOLT 5/16 IN.	4	
20	515416	FLOOR PLATE	1	
21	515415	ARM, FLOOR COVER	1	
22	509177	BOLT 5/16 X 3/4 IN.	2	
23	512881	RIVET AM-54 .....	1	REPLACES 503723
24	511474	BRACKET, ARM	1	
27	508679	SEAL RUBBER	11.8"	
29	509074	PIN COTTER 3/32"	1	
30	514243	CONSOLE COVER	1	
32	492363	BOLT 5/16 X 3/4 IN. NCG5	6	
33	EM923023	WASHER 5/16" .....	6	REPLACES 505679
34	EM923343	WASHER, LOCK 5/16 IN. ....	6	REPLACES 492623
136	507888	SEAT	1	
138	EM923023	NUT 5/16" .....	12	REPLACES 505679
140	2105164	NUT, NYLON 5/16 IN. - 18 .....	4	REPLACES 492582
142	510875	BOLT 3/4 NC X 1-1/2 IN	4	
159	513314	SCREW 1/4" X 3/4"	1	
161	513471	LOCK CLIP	1	
162	513328	LOCKING ARM	1	
163	2101402	WASHER LOCK 1/4" .....	1	REPLACES 492622
164	492410	BOLT 5/8 NC x 2-1/2 IN. G5	1	
166	506167	WASHER, PLASTIC 5/8 IN.	2	
167	EM923023	WASHER, PLAIN 5/16 IN. ....	1	REPLACES 506109
168	EM969023	NUT, LOCK 5/8 IN. ....	1	REPLACES 492586
170	745	LOCK PIN	1	
238	29057	DOCUMENT BOX	1	
240	492356	BOLT 1/4" X 3/4"	2	
242	EM923057	WASHER 1/4 IN. ....	8	REPLACES 492596
243	492581	NUT 1/4"-20 NYLON	2	

# AR-13D RIDE-ON ROLLER — HOOD AND REAR PANEL ASSY.

HOOD AND REAR PANEL ASSY.

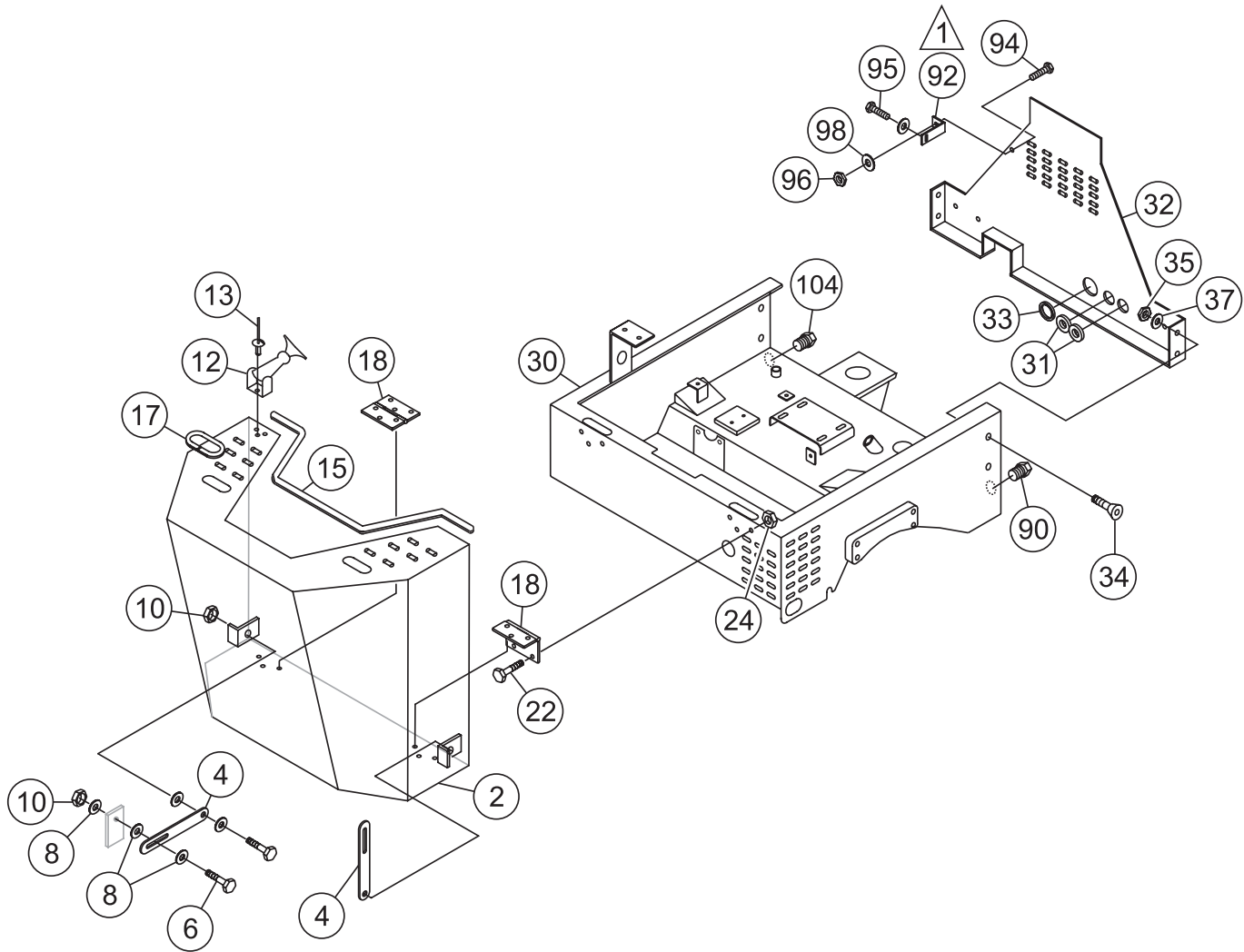

## NOTES:

△ 1 SECURE TO ENGINE

## AR-13D RIDE-ON ROLLER — HOOD AND REAR PANEL ASSY.

### HOOD AND REAR PANEL ASSY.

<u>NO.</u>	<u>PART NO.</u>	<u>PART NAME</u>	<u>QTY.</u>	<u>REMARKS</u>
2	515703	HOOD	1	
4	513305	HINGE, SLOTTED	2	
6	0202	SCREW, HHC 5/16 X 18 X 1 IN. ....	4	REPLACES 492364
8	EM923023	FLAT WASHER 5/16 IN. ....	10	REPLACES 505679
10	2105164	NUT, NYLON 5/16- 18	4	REPLACES 492582
12	491010	LATCH KIT	2	REPLACES 504744
13	512881	RIVET BRAKE LINING	2	REPLACES 503723
15	508679	SEAL RUBBER	56.1"	
17	508679	SEAL RUBBER	23.6"	
18	514438	LATCH KIT (HOOD)	2	
22	492356	BOLT 1/4 X 3/4 IN.	12	
24	492581	NUT 1/4 IN.	12	
30	515645	FRONT CHASSIS	1	
32	513308	REAR ENGINE COVER	1	
33	13212	GROMMET, 1-1/4 IN. ID	1	
34	506158	BOLT 5/16 X 3/4 IN. ....	4	REPLACES 513309
90	490181	SIGHT GLASS	1	
92	516294	SUPPORT REAR ENGINE COVER	1	
94	0202	BOLT 1/4 X 3/4 IN. ....	1	REPLACES 492364
96	2105164	WASHER, LOCK 1/4 IN. ....	1	REPLACES 492622
98	EM923023	FLAT WASHER 5/16 IN. ....	3	REPLACES 492597
100	011208025	BOLT 8 X 25T DCA-85,125,150SSM	1	REPLACES 508342
102	EM923343	WASHER, LOCK 5/16 IN. ....	1	REPLACES 492623
104	506205	PLUG	1	
148	510925	NUT 3/16 IN.	2	
150	513314	BOLT 1/4 X 1/2 IN.	2	
155	EM506085	GROMMET	1	REPLACES 506085



# AR-13D — STEERING COLUMN AND HYDRAULIC ARTICULATION ASSY.

## STEERING COLUMN AND HYDRAULIC ARTICULATION ASSY.

<u>NO.</u>	<u>PART NO.</u>	<u>PART NAME</u>	<u>QTY.</u>	<u>REMARKS</u>
16	EM969023	NUT, LOCK 5/8 IN. ....	2	REPLACES 492586
18	492413	BOLT 5/8" UNC X 3-1/2	1	
19	EM128	BOLT 5/8"NC X 4"G8	1	
22	506196	ELBOW FITTING	2	
24	513297	CYLINDER, STEERING	1	
26	6109210	BOLT 1/2"-13 x 1-1/2 .....	4	REPLACES 492276
28	513299	COVER, ARTICULATING JOINT	1	
30	EM963055	HEX HEAD CAPSCREW 3/8 IN. x 3/4 IN. ....	3	REPLACES 492373
32	6109180	WASHER, LOCK 1/2" DIAMETER .....	8	REPLACES 492626
34	0166A	WASHER, LOCK 3/8" DIAMETER .....	3	REPLACES 492624
36	513300	RETAINER PLATE	1	
38	513301	SPACER	1	
40	506164	BEARING	1	
42	6109210	BOLT 1/2 IN. NC x 1-1/2 IN. G .....	4	REPLACES 492276
44	6109180	WASHER, LOCK 1/2 IN. ....	4	REPLACES 492626
46	513302	BASE, ARTICULATING JOINT	1	
48	513303	ARTICULATING JOINT	1	
50	6109210	BOLT 1/2 IN. NC x 1-1/2 IN. G .....	4	REPLACES 492276
52	491701	ZERK FITTING	1	
54	513350	HOSE, 9	1	
56	513348	HOSE, 16	1	
58	491008	GREASE COVER	1	
172	509156	NUT	1	
174	493128	WHEEL, STEERING	1	
176	507862	STEERING COLUMN .....	1	REPLACES 5061861
178	506265	NUT 5/16 IN.	4	
181	513346	HOSES K AND L	2	
182	EM923343	WASHER 5/16 IN. ....	4	REPLACES 492623
184	508335	BUSHING	4	
186	509190	WASHER 3/4 IN.	1	
188	506186	HYDRAULIC VALVE	1	
190	18706	HOUR METER	1	
192	503119	NUT, LOCK 3/16"	1	
194	692318	SWITCH, STARTER	1	
195	691959	KEY, IGNITION	1	
198	492356	BOLT 1/4 IN. x 3/4 IN.	1	
200	EM969079	NUT 1/4 IN. ....	1	REPLACES 492581
202	515791	HARNESS, WIRING	1	
390	515971	INDICATOR, GAUGE, ENGINE STATUS	1	
391	515848	CIRCUIT BREAKER	1	

# AR-13D RIDE-ON ROLLER — ARTICULATION ARM ASSY.

## ARTICULATION ARM

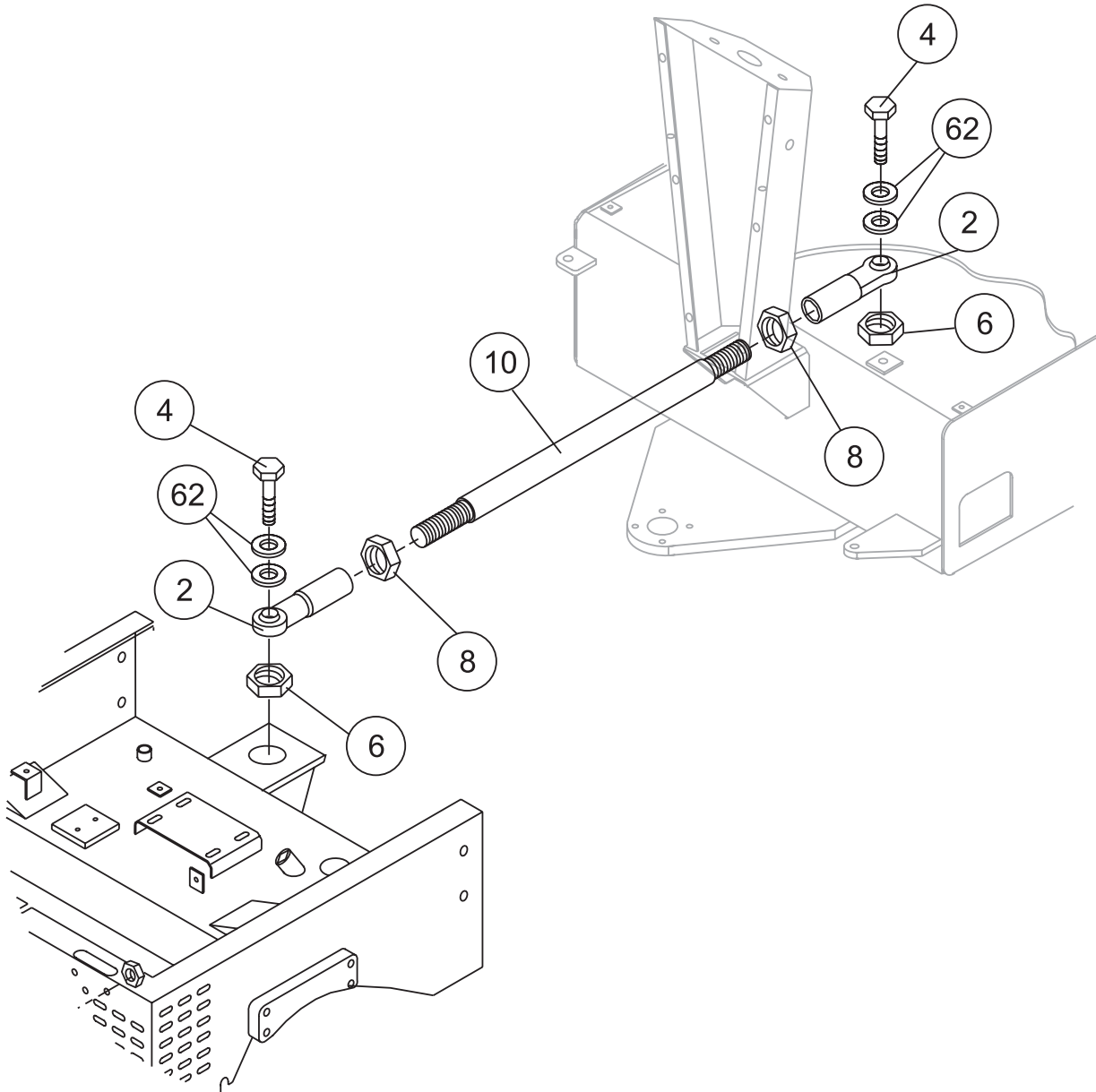

## AR-13D RIDE-ON ROLLER — ARTICULATION ARM ASSY.

### ARTICULATION ARM

<u>NO.</u>	<u>PART NO.</u>	<u>PART NAME</u>	<u>QTY.</u>	<u>REMARKS</u>
2	513294	ROD END	2	
4	514347	BOLT 3/4 IN. x 2-1/2 IN.	2	
6	EM505069	NUT 3/4 IN.	2	
8	513295	NUT 3/4 IN.	2	
10	513296	ROD, DIRECTION STABILIZER	1	
62	514433	FLAT WASHER 3/4.	4	

# AR-13D RIDE-ON ROLLER — HYDRAULIC DRIVE PUMP ASSY.

HYDRAULIC DRIVE PUMP ASSY.

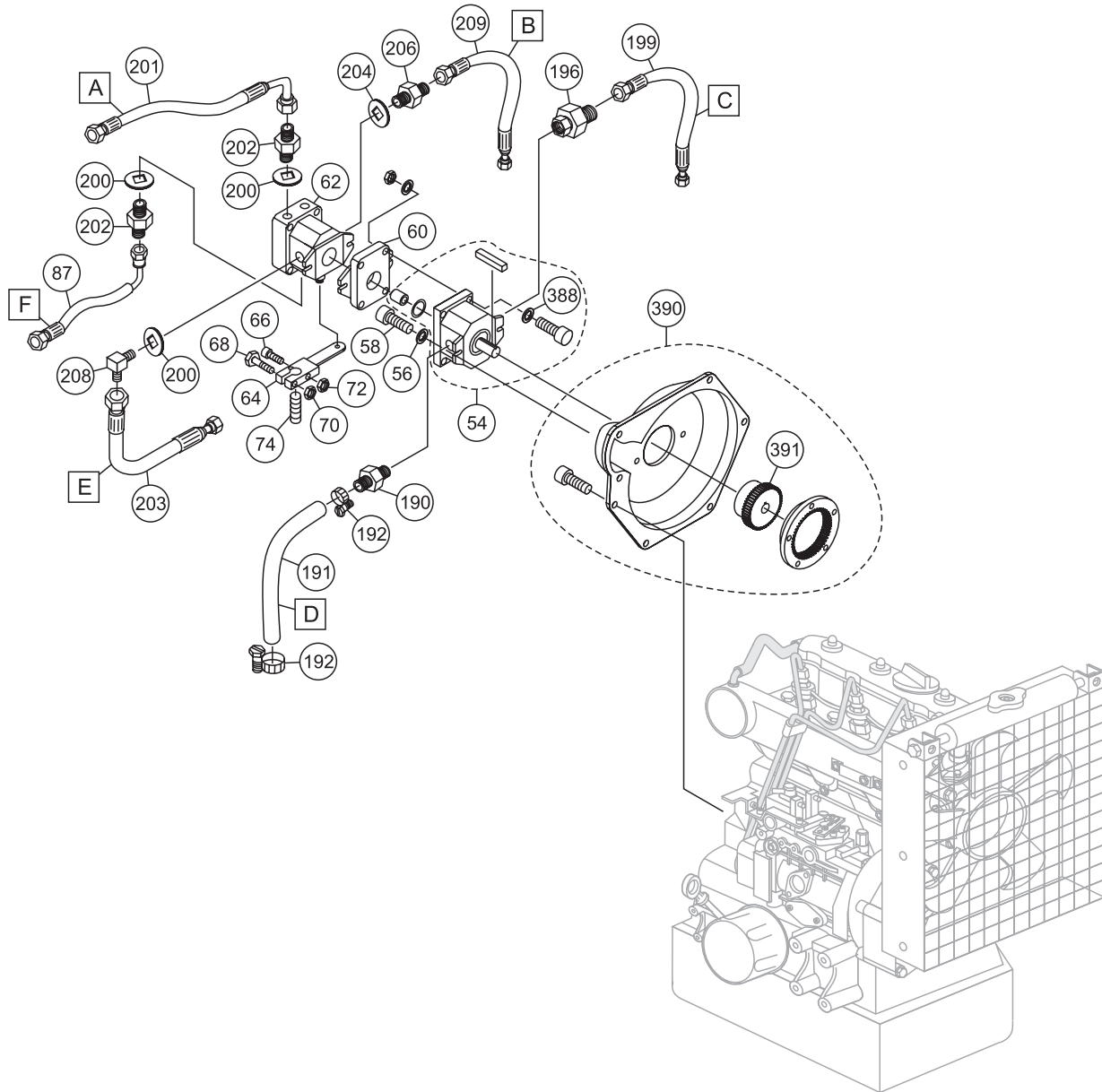

## NOTES

A	C	A	SEE HYDRAULIC HOSE CONNECTIONS
B	D	B	

## AR-13D RIDE-ON ROLLER — HYDRAULIC DRIVE PUMP ASSY.

### HYDRAULIC DRIVE PUMP ASSY.

<u>NO.</u>	<u>PART NO.</u>	<u>PART NAME</u>	<u>QTY.</u>	<u>REMARKS</u>
36	515803	ENGINE, BRIGGS AND STRATTON 850D	1	
54	507845	PUMP, STEERING	1	
56	EM508346	WASHER 3/8 IN. ....	2	REPLACES 508346
58	EM175	BOLT 3/8-16 X 1-1/4 SC HD	2	
60	507860	ADAPTER, STEERING PUMP	1	
62	506187	HYDRAULIC PUMP	1	
64	513310	SHIFT LEVER	1	
66	509144	BOLT 3/16 X 1-3/4 IN.	1	
68	2105162	BOLT 5/16 X 1-3/4 IN. ....	1	REPLACES 492367
70	2105164	NUT, NYLON 5/16 IN. - 18 .....	1	REPLACES 492582
72	503119	NUT, LOCK 3/16 IN.	1	
74	513489	SCREW ALLEN HEAD 1/4 - 20 X 3/8 IN. ....	1	REPLACES 492465
87	515727	HOSE	2	
190	506217	FITTING 3/4 IN.	1	
191	515723	HOSE	1	
192	506207	HOSE CLAMP, HS-16	2	
196	506203	FITTING	1	
199	515725	HOSE	1	
200	508427C	COPPER WASHER 21/32 IN.	3	
201	515726	HOSE	1	
202	508343	FITTING	3	
203	513339	HOSE	1	
204	508428C	COPPER WASHER 5/8 IN.	1	
206	506219	FITTING 1/2 IN.	1	
208	506195	FITTING 3703-08-08	1	
209	515724	HOSE	1	
388	EM923343	WASHER LOCK 5/16" .....	4	REPLACES 492623
390	515811	COUPLING, FLYWHEEL ASSY .....	1	INCLUDES ITEMS W/#
391#	515811H	HUB, DRIVE	1	

# AR-13D RIDE-ON ROLLER — MANIFOLD AND HYDRAULIC OIL FILTER ASSY.

## MANIFOLD AND HYDRAULIC OIL FILTER ASSY.

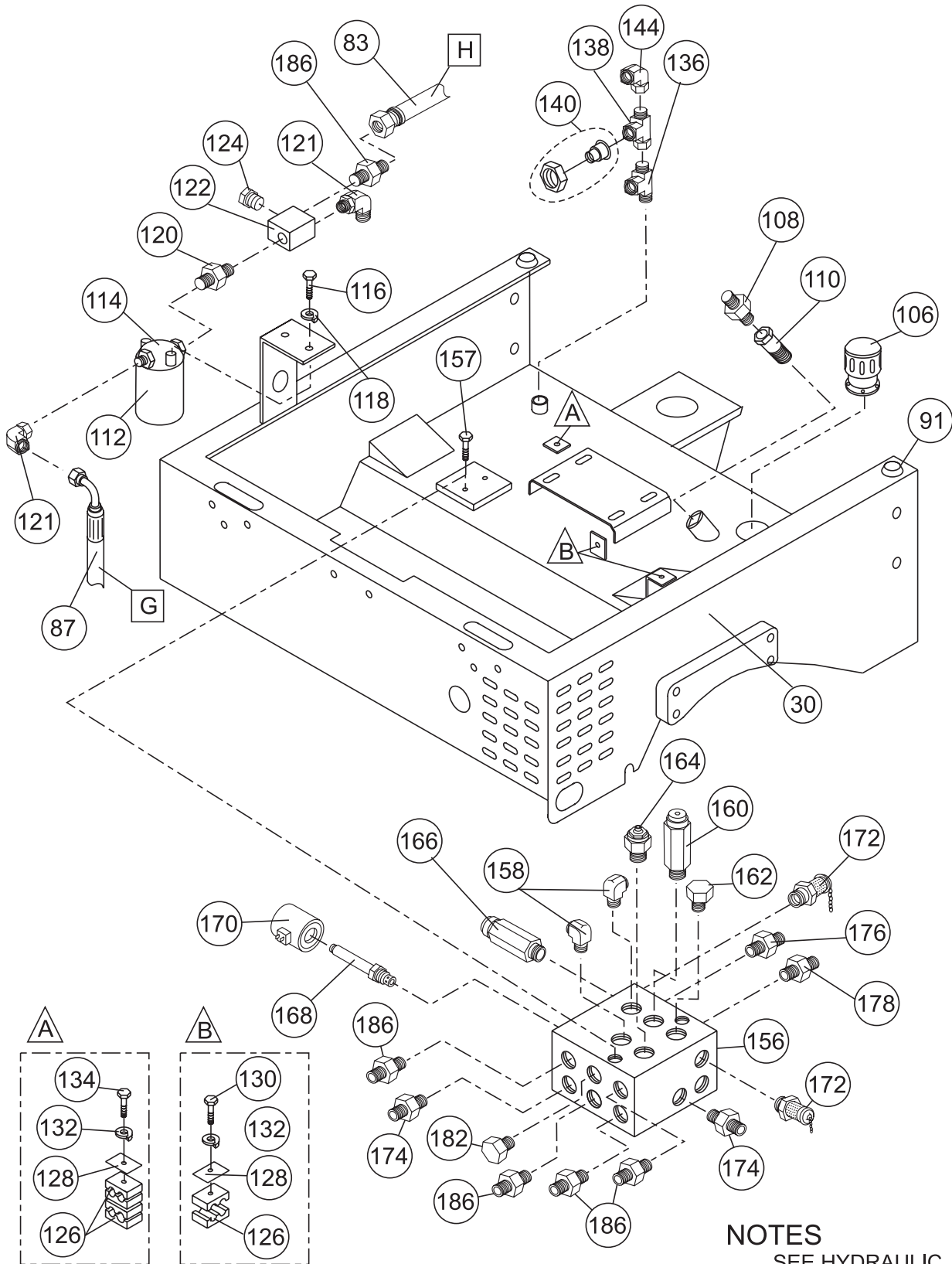

### NOTES

**G H** SEE HYDRAULIC HOSE CONNECTIONS PAGE 34-35

## AR-13D RIDE-ON ROLLER — MANIFOLD AND HYDRAULIC OIL FILTER ASSY.

### MANIFOLD AND HYDRAULIC OIL FILTER ASSY.

<u>NO.</u>	<u>PART NO.</u>	<u>PART NAME</u>	<u>QTY.</u>	<u>REMARKS</u>
30	515645	CHASSIS AR13D	1	
83	513221	HOSE	1	
87	515727	HOSE	1	
91	EM505186	CUSHION RUBBER .....	2 .....	REPLACES 505186
106	507278	HYDRAULIC TANK CAP	1	
108	506218	STRAIGHT FITTING 3/4"	1	
110	506221	FILTER	1	
112	508667	OIL FILTER	1	
114	508664	FILTER, HEAD	1	
116	492356	BOLT 1/4" X 3/4"	2	
118	2101402	WASHER, LOCK 1/4" .....	2 .....	REPLACES 492622
120	506204	FITTING	1	
121	EM25507	FITTING	2	
122	506244	BLOCK FILTER M10	1	
124	508670	VALVE CHECK	1	
126	505976	CLAMP 3/4	3	
128	506185	PLATE CORNER	3	
130	2105162	SCREW, HHC5/16"-18X1-3/4" .....	2 .....	REPLACES 492367
132	EM923343	WASHER, LOCK 5/16" .....	3 .....	REPLACES 492623
134	492371	BOLT 5/16" LOCK	1	
136	506201	FITTING, TEE	1	
138	506202	FITTING	1	
140	506206	FITTING	1	
144	506195	FITTING	1	
156	515502	MANIFOLD	1	
157	508814	BOLT 5/16"X3-1/4"	2	
158	506192	FITTING	2	
160	507774	VALVE RELIEF, 500 PSI	1	
162	507772	PLUG	1	
164	506247	VALVE, NEEDLE	1	
166	506246	VALVE, RELIEF, 2000 PSI	1	
168	506245	VALVE, SOLENOID	1	
170	507885	12 VOLT COIL SOLENOID	1	
172	506182	COUPLING PSI TEST	3	
174	506190	FITTING	2	
176	511808	ADAPTER, STRAIGHT	2	
178	506190	FITTING	2	
182	506205	PLUG	1	
186	506193	FITTING	5	



# AR-13D RIDE-ON ROLLER — FUEL TANK & OIL DRAIN HOSE ASSY.

## FUEL TANK & OIL DRAIN HOSE ASSY.

<u>NO.</u>	<u>PART NO.</u>	<u>PART NAME</u>	<u>QTY.</u>	<u>REMARKS</u>
124	508302	PAD, RUBBER TANK	2	
204	513329	FUEL TANK	1	
205	514467	BRACKET, FUEL TANK SUPPORT	1	
206	34507	CAP, FUEL W/GAUGE	1	
207	514340	PAD, RUBBER BRACKET 4 x 36 x 10 mm	5.6'	
208	505594	FLEX TUBE 5/16 IN.	1	
210	514560	ADAPTER, ELBOW	1	
212	492309	BOLT 3/8 NC x 3/4 IN. G5	2	
213	EM923343	WASHER, LOCK 5/16 IN. ....	2	REPLACES 492623
214	3019092	WASHER, FLAT 3/8 IN.	2	
216	2105164	NUT, HEX 5/16 IN. ....	2	REPLACES 492553
218	506208	CLAMP HS-4	12	
220	514536	HOSE 4FLH 5/16 IN.	4.1'	
221	514536	HOSE 4FLH 5/16 IN.	.7'	
248	512731	ADAPTOR	2	
252	512731	ADAPTOR	2	
256	EM512722	FUEL SHUT-OFF VALVE	1	
268	511778	ADAPTER	2	
270	514536	HOSE 4FLH 5/16 IN.	4.1'	
284	491210	PLUG, TANK 1/4 IN.	1	
285	505594	FLEX TUBE 5/16 IN.	1	
290	514536	HOSE 4FLH 5/16 IN.	4.1'	
292	EM20427	HOSE 4FLH 5/16 IN.	4'	
294	514560	HOSE 4FLH 5/16 IN.	4.6'	
342	515697	FILTER SUPPORT	1	
344	011208025	BOLT 8 X 25T .....	2	REPLACES 508342
346	EM923343	WASHER 5/16 IN. ....	2	REPLACES 492623
362	492363	BOLT 5/16" NC X 3/4" G5	2	
364	492582	NUT 5/16"-18	2	
398	825219	FUEL FILTER ASSY W/SENSOR	1	
400	516416	ENGINE OIL DRAIN	1	
401	516417	FITTING 90°	1	
402	516353	HOSE	1	
403	513619	FITTING	1	
404	820311	FUEL, FILTER ELEMENT W/O SENSOR	1	
405	820347	SENSOR, FUEL FILTER	1	

# AR-13D RIDE-ON ROLLER — WATERTANK ASSY.

WATER TANK ASSEMBLY ASSY.

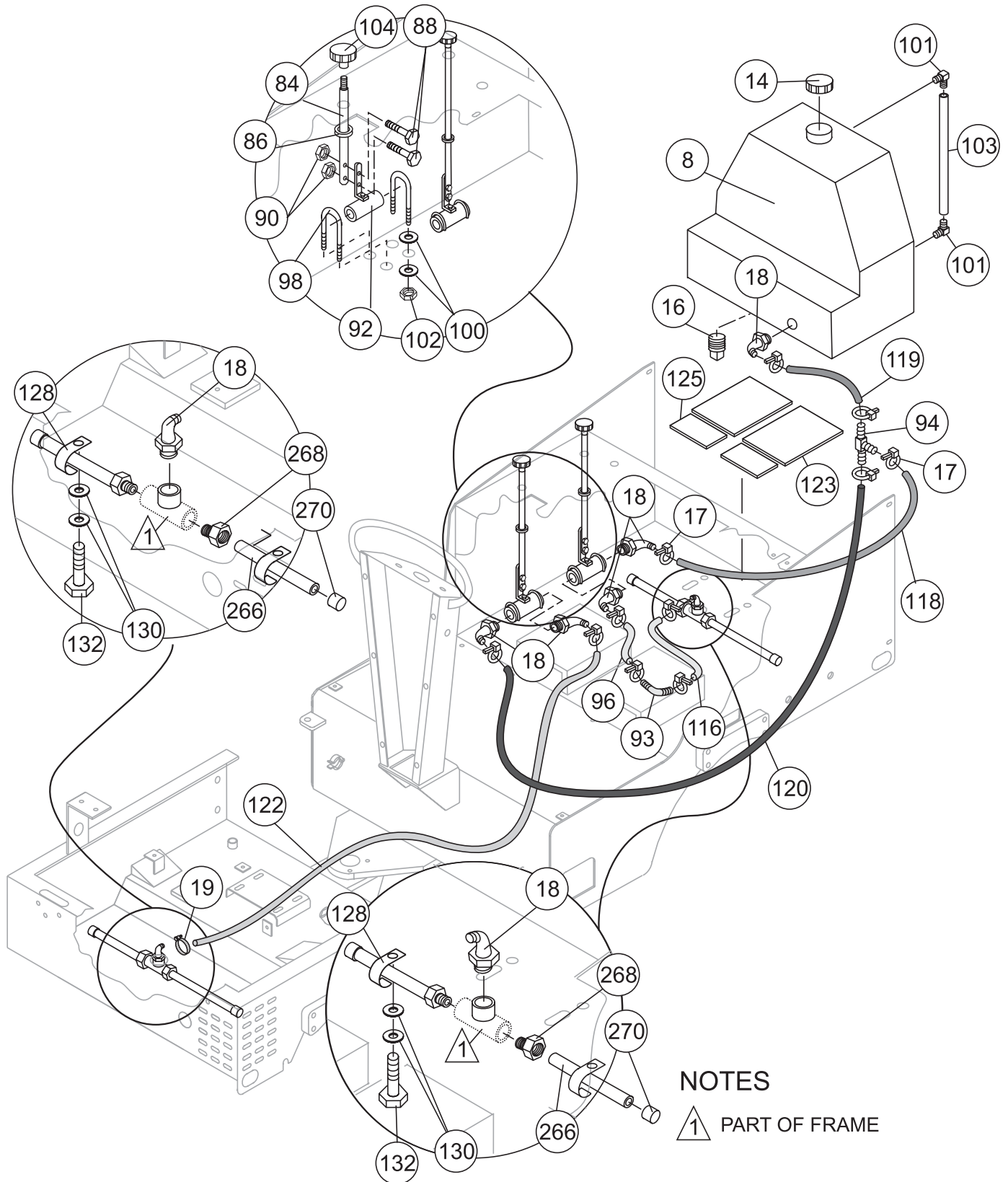

## NOTES

△ PART OF FRAME

## AR-13D RIDE-ON ROLLER — WATER TANK ASSY.

### WATER TANK ASSEMBLY ASSY.

<u>NO.</u>	<u>PART NO.</u>	<u>PART NAME</u>	<u>QTY.</u>	<u>REMARKS</u>
8	513316	WATER TANK	1	
14	509249	WATER TANK CAP	1	
16	514541	PLUG	1	
17	491028	CLAMP	10	
18	506071	ELBOW PVC	7	
19	506288	CLAMP	1	
84	513321	WATER VALVE EXTENSION	1	
86	EM506085	GROMMET	2	
88	EM492358	BOLT 1/4" NC x 1-1/4" G5	4	
90	492581	NUT 1/4"	4	
92	513322	VALVE, BALL	2	
93	513351	ELBOW 90G 1/2" NYLON	1	
94	513379	"T" ADAPTER	1	
96	402010060	HOSE 1/2" .....	1.3'	REPLACES 504163
98	506086	U- BOLT 3/8"	4	
100	3019092	WASHER, FLAT. 3/8" .....	16	REPLACES 492598
101	EM20426	ELBOW BRASS	2	
102	508435	LOCK NUT	8	
103	EM20415	TUBE 5/16"	2.3'	
104	503015	KNOB, HANDLE ADJ.	2	
116	402010060	HOSE 1/2" .....	.33'	REPLACES 504163
118	402010060	HOSE 1/2" .....	.66'	REPLACES 504163
119	402010060	HOSE 1/2" .....	2'	REPLACES 504163
120	402010060	HOSE 1/2" .....	.5'	REPLACES 504163
122	402010060	HOSE 1/2" .....	6.2'	REPLACES 504163
123	508301	PAD, WATER TANK	2	
125	508251	PAD, WATER TANK	2	
128	506084	CLAMP	4	
130	EM923023	NUT 5/16" .....	4	REPLACES 505679
132	EM492299	SCREW, HHC 5/16" - 18X1/2" .....	4	REPLACES 505401
266	506072	PVC TUBE	4	
268	506074	MALE ADAPTER	4	
270	508610	CAP	4	

# AR-13D RIDE-ON ROLLER — ENGINE MOUNTING ASSY.

ENGINE MOUNTING ASSY.

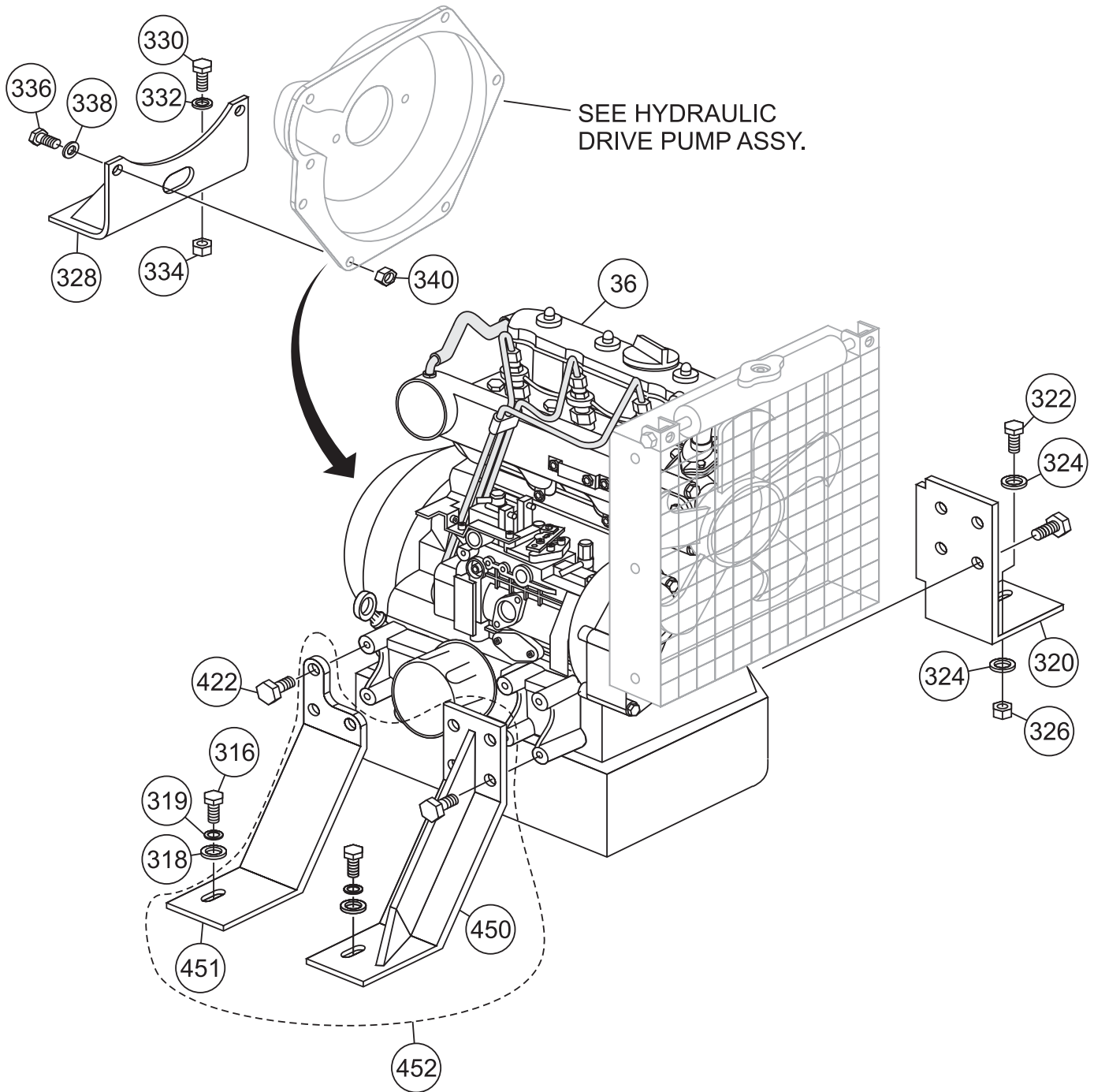

## AR-13D RIDE-ON ROLLER — ENGINE MOUNTING ASSY.

### ENGINE MOUNTING ASSY.

<u>NO.</u>	<u>PART NO.</u>	<u>PART NAME</u>	<u>QTY.</u>	<u>REMARKS</u>
36	515803	DIESEL ENGINE, BRIGGS AND STRATTON 850D .....	1 .....	INCLUDES ITEMS W/#
316	515800	BOLT 7/16"NC X 1" G5	2	
318	492599	WASHER 7/16"	2	
319	492625	WASHER 7/16"	2	
320	515659	MOUNT, ENGINE	1	
322	EM963057	CAPSCREW 3/8"X1-1/2" .....	2 .....	REPLACES 492313
324	3019092	WASHER FLAT 3/8" .....	4 .....	REPLACES 492598
326	EM969013	NUT NYLOC .....	2 .....	REPLACES 492583
328	515650	MOUNT, ENGINE	1	
330	EM963610	CAPSCREW 3/8"NC X 1-1/4" G8 .....	2 .....	REPLACES 492376
332	3019092	WASHER FLAT 3/8" .....	2 .....	REPLACES 492598
334	EM969013	NUT NYLOC .....	2 .....	REPLACES 492583
336	2105162	SET BOLT ENGINE .....	2 .....	REPLACES 492367
338	EM923023	WASHER PLAIN 5/16" .....	2 .....	REPLACES 492597
340	2105164	NUT 5/16" .....	2 .....	REPLACES 492582
450#@		MOUNT, ENGINE	1	
451#@		MOUNT, ENGINE	1	
452#	835034	ENGINE MOUNT KIT .....	1 .....	INCLUDES ITEMS W/@

# AR-13D RIDE-ON ROLLER — MUFFLER ASSY.

MUFFLER ASSY.

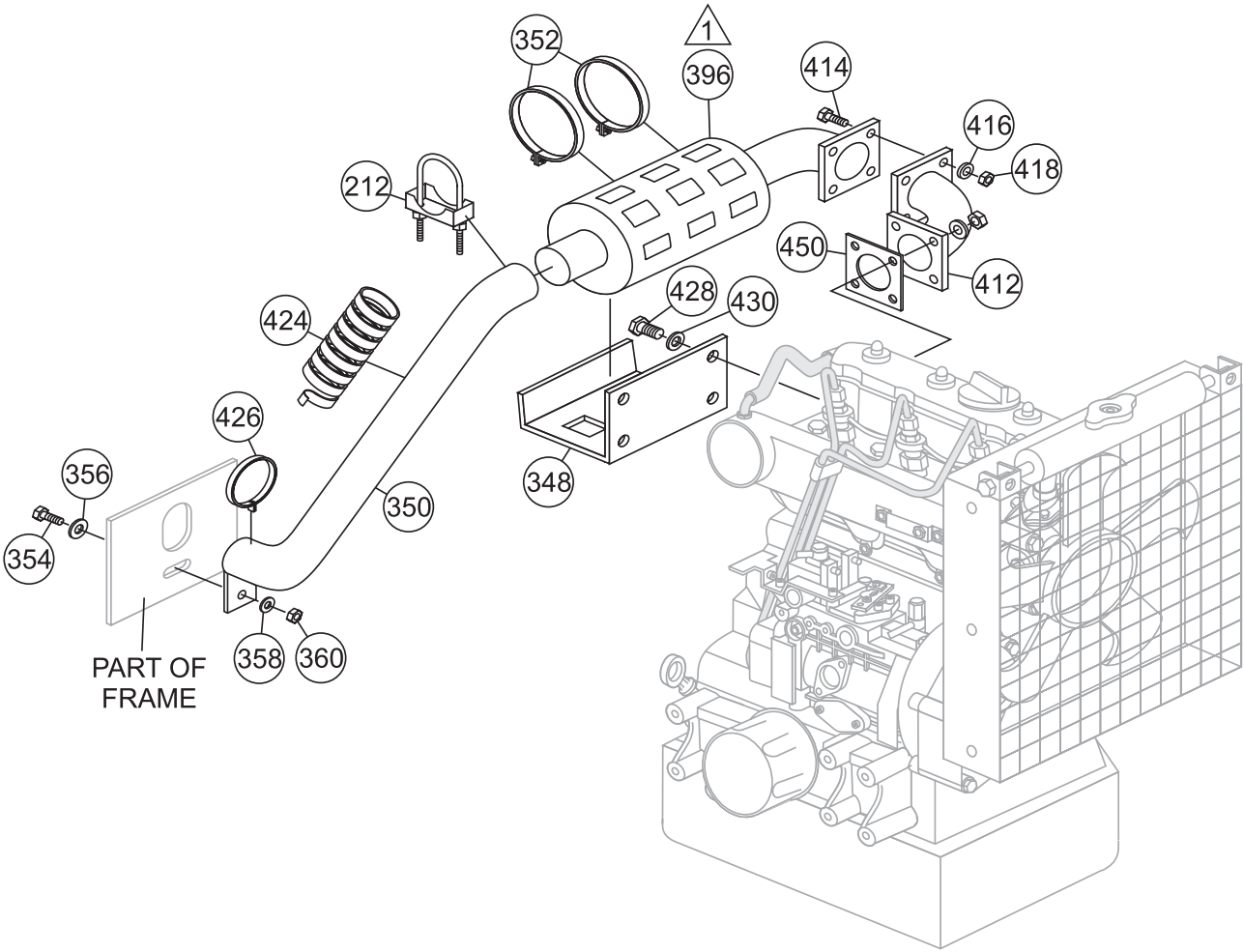

## NOTES

▲ MUFFLER SOLD WITH ENGINE

## AR-13D RIDE-ON ROLLER — MUFFLER ASSY.

### MUFFLER ASSY.

<u>NO.</u>	<u>PART NO.</u>	<u>PART NAME</u>	<u>QTY.</u>	<u>REMARKS</u>
212	506257	U-BOLT	1	
348	515667	MOUNT PLATE, MUFFLER	1	
350	515663	MUFFLER BASE EXTENSION	1	
352	493108	CLAMP	2	
354	0202	SCREW, HHC 5/16-18 X 1 .....	1	REPLACES 492364
356	EM923023	WASHER FLAT 5/16 .....	1	REPLACES 492597
358	EM923343	WASHER FLAT 5/16 .....	1	REPLACES 492623
360	2105164	NUT 5/16.....	1	REPLACES 492553
396	835029	MUFFLER .....	1	INCLUDED WITH ENGINE
412	516291	ELBOW, EXHAUST	1	
414	0202	SCREW, HHC 5/16-18 X 1 .....	4	REPLACES 492364
416	EM923343	WASHER LOCK 5/16" .....	4	REPLACES 492623
418	2105164	NUT HEX 5/16" DIA-NC .....	4	REPLACES 492553
424	517127	WRAP 2" X 1/16" X 8' .....	11.5'	REPLACES 510718
426	517328	CLAMP	1	
428	506886	BOLT	4	
430	EM923343	WASHER LOCK 5/16" .....	4	REPLACES 492623
450	821001	GASKET, EXHAUST MANIFOLD	1	

# AR-13D RIDE-ON ROLLER — AIR CLEANER ASSY.

AIR CLEANER ASSY.

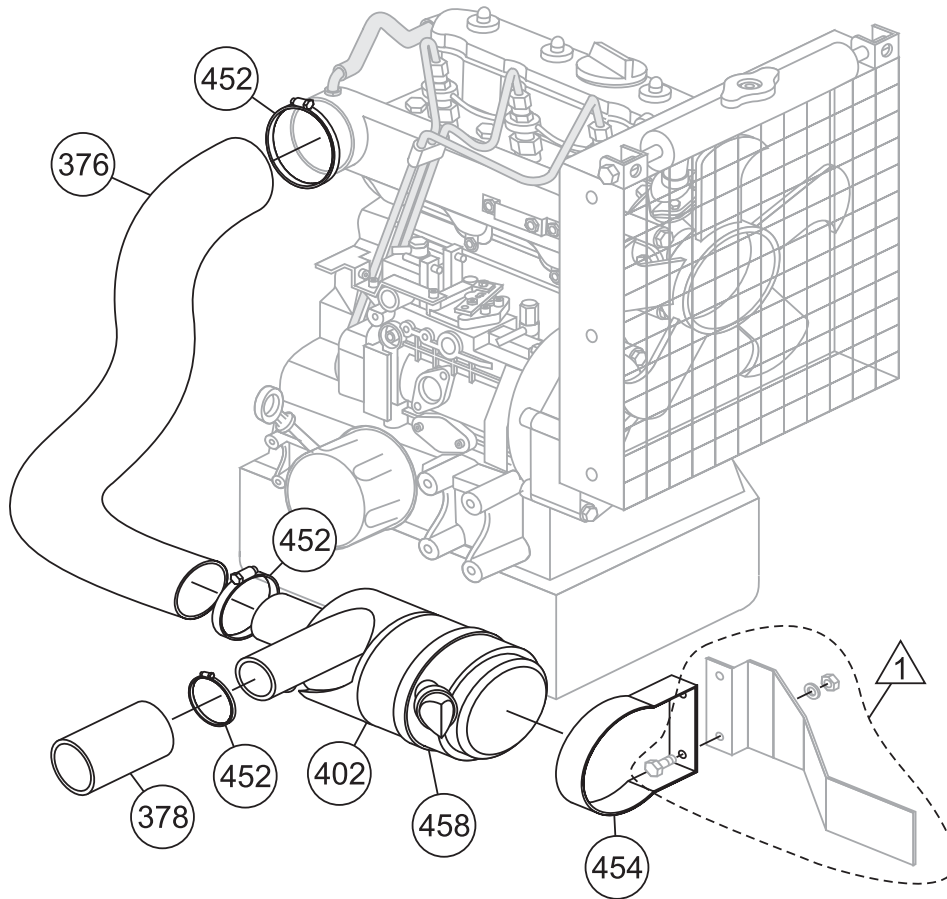

## NOTES

- ① ITEMS WITHIN DASHED LINE ARE INCLUDED WITH RADIATOR MOUNTING KIT. SEE RADIATOR ASSY.

## AR-13D RIDE-ON ROLLER — AIR CLEANER ASSY.

### AIR CLEANER ASSY.

<u>NO.</u>	<u>PART NO.</u>	<u>PART NAME</u>	<u>QTY.</u>	<u>REMARKS</u>
376	515801	AIR INTAKE HOSE	1	
378	515696	HOSE AIR INLET	1	
402	835007	AIR CLEANER .....	1 .....	INCLUDED WITH ENGINE
452	515802	CLAMP	3	
454		MOUNT, AIR CLEANER .....	1 .....	INCLUDED WITH ITEM 402
458	M113621	ELEMENT, AIR FILTER	1	

# AR-13D RIDE-ON ROLLER — RADIATOR ASSY.

## RADIATOR ASSY.

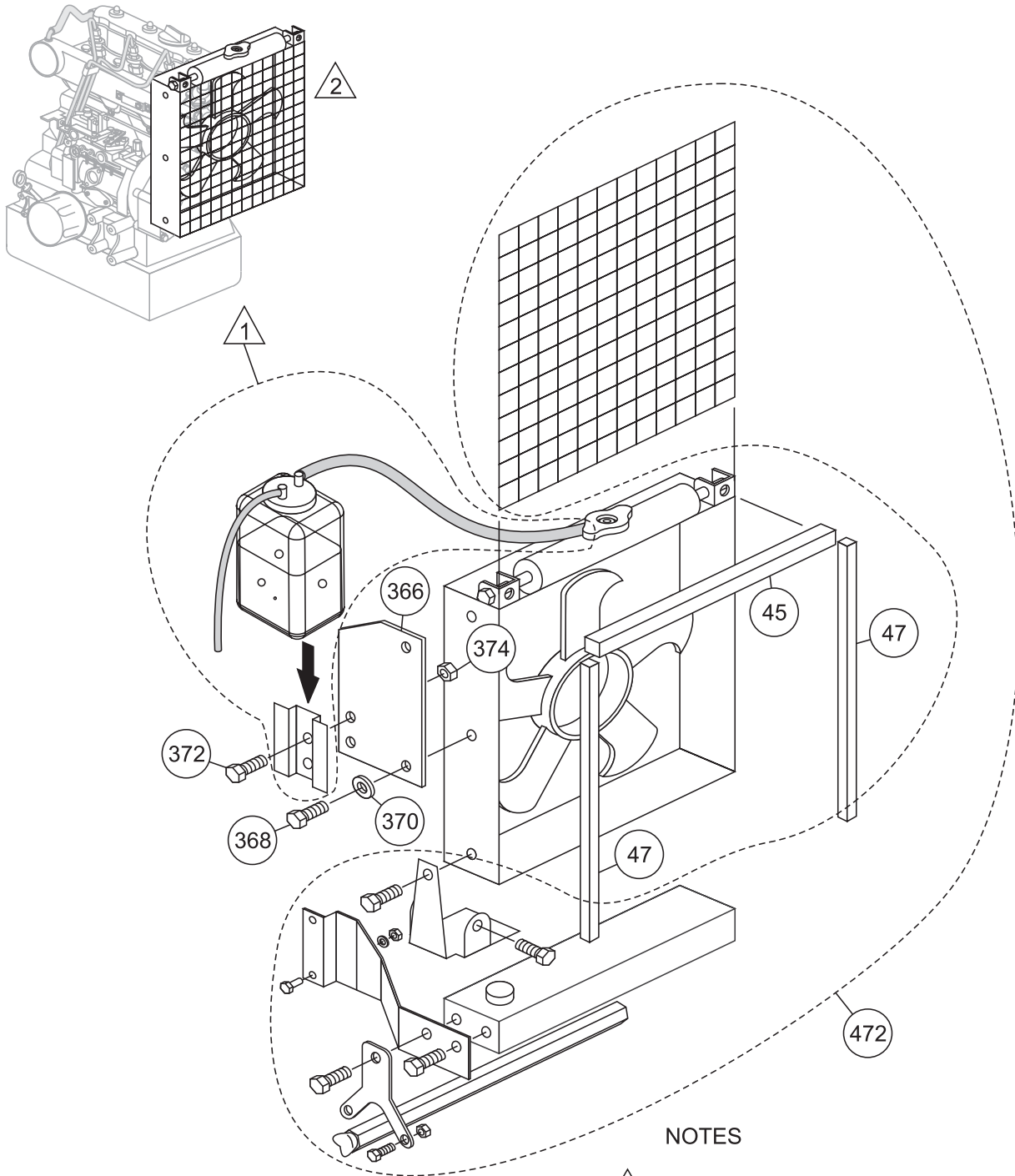

### NOTES

- ① ITEMS WITHIN DASHED LINE ARE INCLUDED WITH ENGINE. REFER TO ENGINE PARTS MANUAL.
- ② RADIATOR INCLUDED WITH ENGINE. REFER TO ENGINE PARTS MANUAL.

## AR-13D RIDE-ON ROLLER — RADIATOR ASSY.

### RADIATOR ASSY.

<u>NO.</u>	<u>PART NO.</u>	<u>PART NAME</u>	<u>QTY.</u>	<u>REMARKS</u>
45	516422	TRIM EDGE 1" X 1"	2.62'	
47	516421	TRIM EDGE 3/4" X 3/4"	2.62'	
366	515660	MOUNT RADIATOR OVERFLOW	1	
368	EM506599	BOLT HEX 6MM X 15 .....	2 .....	REPLACES 506599
370	2101402	WASHER SPRING 1/4" .....	2 .....	REPLACES 492622
372	492356	BOLT 1/4" X 3/4"	2	
374	492581	NUT 1/4"-20 NYLON LOCK	2	
472	835085	RADIATOR MOUNTING KIT	1	



## AR-13D RIDE-ON ROLLER — THROTTLE ASSY.

### THROTTLE ASSY.

<u>NO.</u>	<u>PART NO.</u>	<u>PART NAME</u>	<u>QTY.</u>	<u>REMARKS</u>
106	513323	TRAVEL LEVER (FWD/REV)	1	
108	513324	CABLE, FORWARD/REVERSE	1	
110	516487	JOINT BALL	1	
112	508451	LOCK NUT 1/4" - 28 NF	1	
114	513325	ADVANCE CABLE SUPPORT	1	
134	510229	CABLE THROTTLE ASSEMBLY	1	
135	DY160701	KNOB HANDLE	1	
136	DA1252	LEVER HANDLE	1	
137	516116	NUT 1/4-20 HEX	1	
330	EM968435	NUT	1	

# AR-13D RIDE-ON ROLLER — BRAKE CONTROL ASSY.

BRAKE CONTROL ASSY.

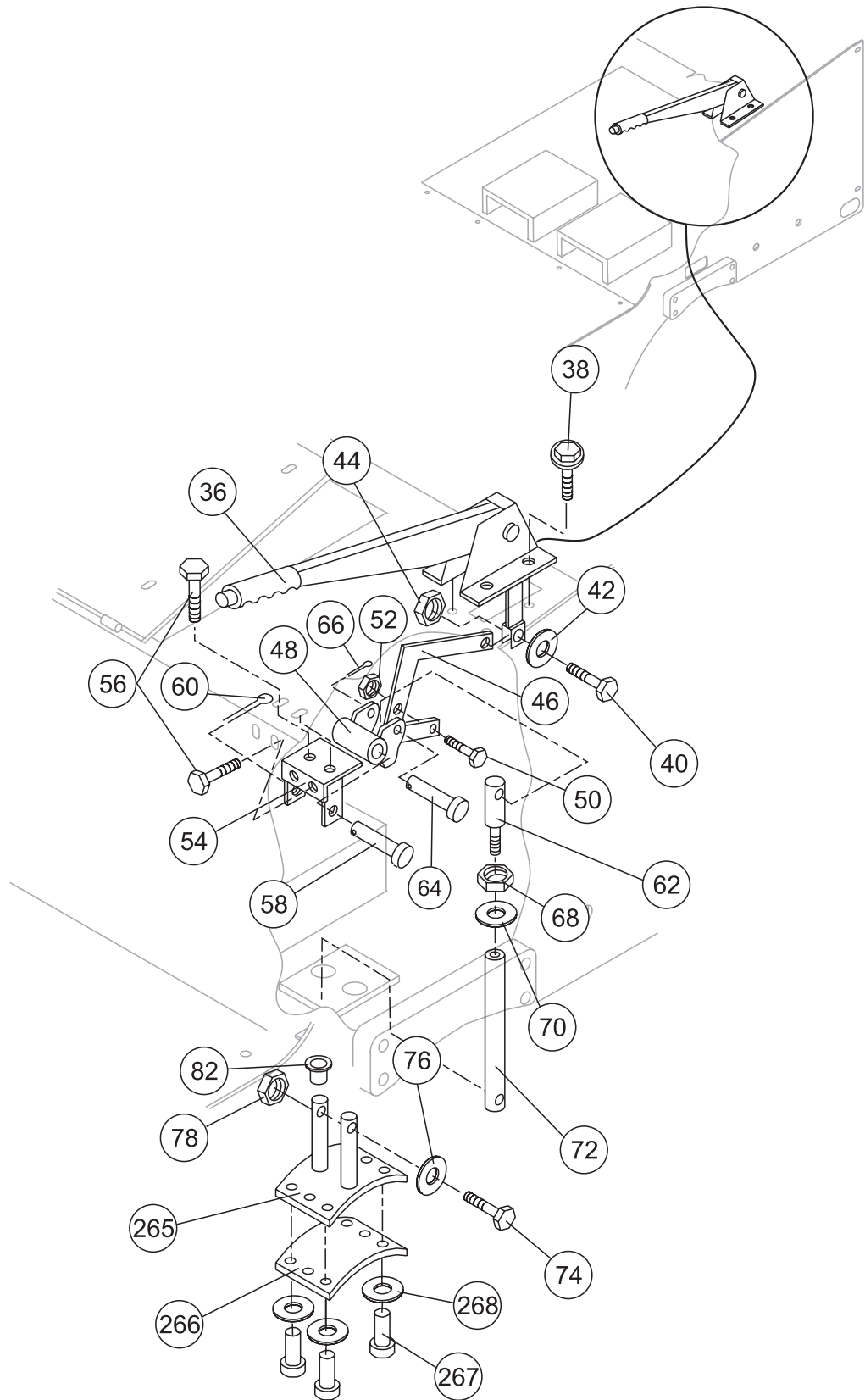

## AR-13D RIDE-ON ROLLER — BRAKE CONTROL ASSY.

### BRAKE CONTROL ASSY.

<u>NO.</u>	<u>PART NO.</u>	<u>PART NAME</u>	<u>QTY.</u>	<u>REMARKS</u>
36	506046	LEVER, BRAKE	1	
38	506158	BOLT 5/16" NC x 3/4" G5	4	
40	492303	BOLT 5/16" NC x 1/1/4" G5 .....	1 .....	REPLACES 492365
42	EM923023	WASHER, FLAT 5/16" .....	2 .....	REPLACES 492597
44	2105164	NUT, NYLON 5/16"- 18 .....	1 .....	REPLACES 492582
46	506057	BRAKE LINK	1	
48	505999	BELL CRANK	1	
50	EM963097	BOLT 3/8" NC x 1/1/2" G5 .....	1 .....	REPLACES 492313
52	EM969013	NUT, LOCK 3/8" .....	1 .....	REPLACES 492583
54	506000	BRACKET, BRAKE	1	
56	508674	BOLT 5/16" NC x 1" G5	4	
58	506042	PIN, CLEVIS	1	
60	506044	KEY, COTTER	1	
62	508450	ROD BRAKE UPPER	1	
64	506043	PIN, CLEVIS	1	
66	2219	KEY, COTTER .....	1 .....	REPLACES 491687
68	4702	NUT, HEX 5/8" .....	1 .....	REPLACES 492570
70	EM923348	WASHER, LOCK 5/8" .....	1 .....	REPLACES 492627
72	508449	BRAKE ROD	1	
74	503116	BOLT, HEX HEAD 3/8" NCX4"	1	
76	3019092	WASHER, FLAT 3/8" .....	2 .....	REPLACES 492598
78	EM969013	NUT, LOCK 3/8" .....	1 .....	REPLACES 492583
82	506001	BUSHING, PLASTIC	1	
265	513320	SUPPORT, BRAKE SHOE	1	
266	505997	BRAKE PAD	1	
267	508566	RIVET	6	
268	508386	WASHER 3/16"	6	

# AR-13D RIDE-ON ROLLER — BATTERY ASSY.

BATTERY ASSY.

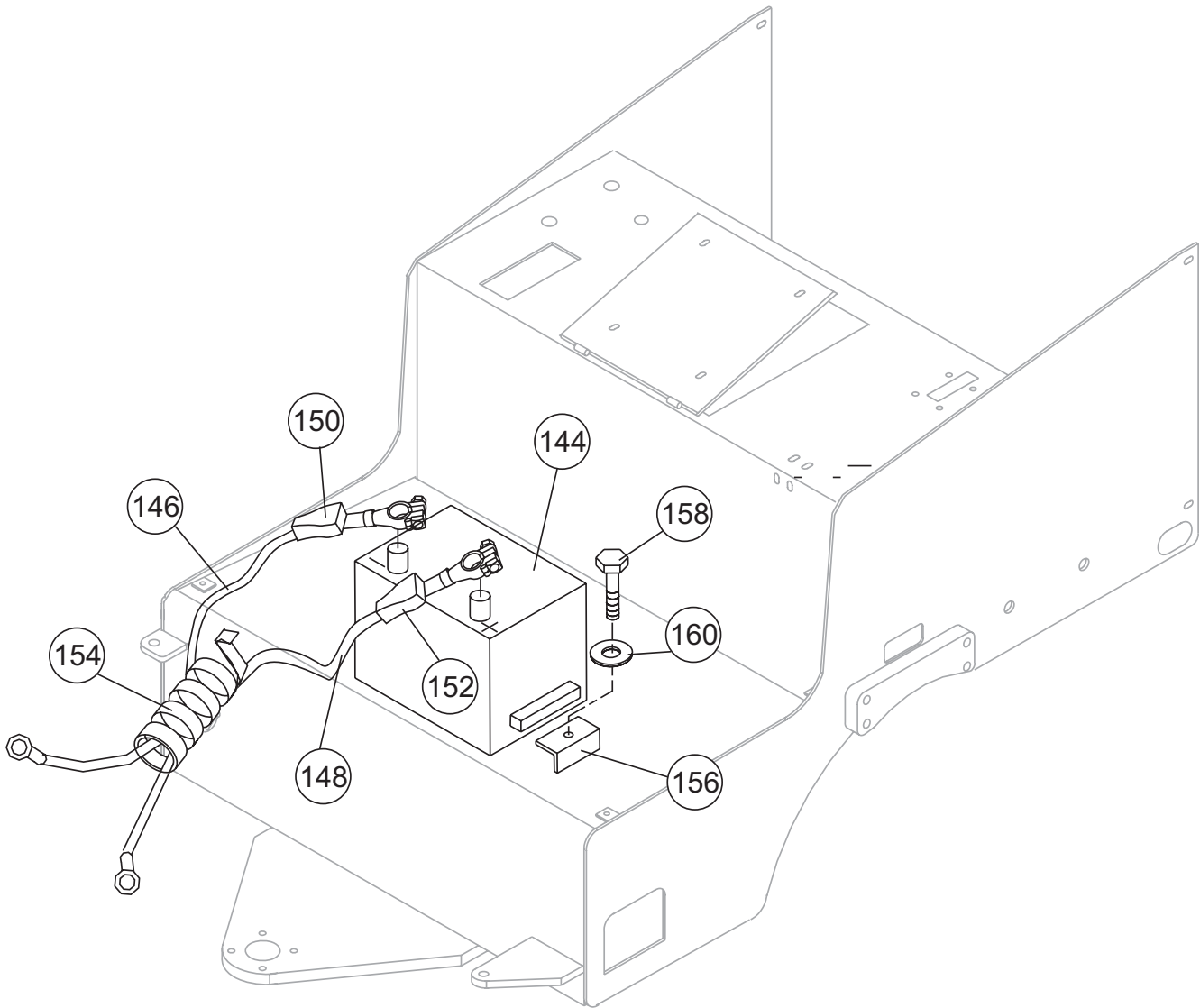

## NOTES:

REMOVE ITEMS 20  
AND 29 ON PAGE 58  
FOR BATTERY ACCESS

## AR-13D RIDE-ON ROLLER — BATTERY ASSY.

### BATTERY ASSY.

<u>NO.</u>	<u>PART NO.</u>	<u>PART NAME</u>	<u>QTY.</u>	<u>REMARKS</u>
144	514391	BATTERY 12V	1	
146	515119	CABLE (-) BATTERY	1	
148	515115	CABLE (+) BATTERY	1	
150	505624	BATTERY TERMINAL COVER .....	1 .....	BLACK
152	506266	BATTERY TERMINAL COVER .....	1 .....	RED
154	506153	WRAP	1	
156	514387	CLAMP, BATTERY	1	
158	492359	HEX HEAD SCREW 3/8"X2" NC G5	1	
160	2101402	WASHER, LOCK 1/4" .....	1 .....	REPLACES 492622

# AR-13D RIDE-ON ROLLER — SCRAPER ASSY.

SCRAPER ASSY.

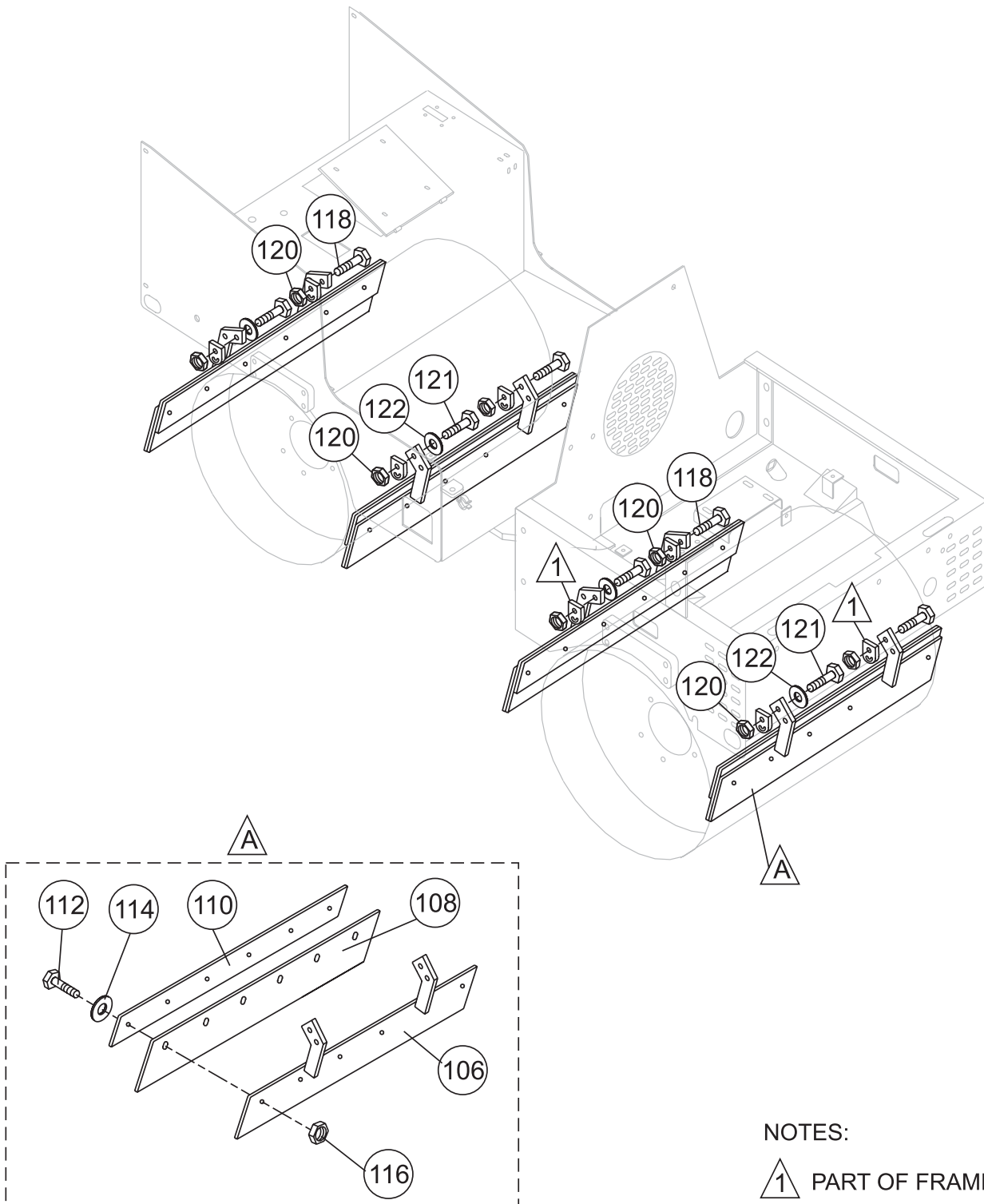

NOTES:

△ 1 PART OF FRAME

## AR-13D RIDE-ON ROLLER — SCRAPER ASSY.

### SCRAPER ASSY.

<u>NO.</u>	<u>PART NO.</u>	<u>PART NAME</u>	<u>QTY.</u>	<u>REMARKS</u>
106	513290	SCRAPER, SUPPORT	4	
108	508433	SCRAPER, RUBBER	4	
110	508434	PLATE BACKING	4	
112	EM963057	BOLT 3/8" .....	12	REPLACES 492313
114	3019092	WASHER, FLAT3/8" .....	12	REPLACES 492598
116	EM969013	NUT, LOCK 3/8" .....	12	REPLACES 492583
118	EM963692	BOLT, 1/2" UNC X 1-1/2" .....	8	REPLACES 492394
120	492584	NUT, LOCK 1/2" NC	8	
122	621	WASHER 1/2" SPECIAL	8	

**PAYMENT TERMS**

Terms of payment for parts are net 30 days.

**FREIGHT POLICY**

All parts orders will be shipped collect or prepaid with the charges added to the invoice. All shipments are F.O.B. point of origin. Multiquip's responsibility ceases when a signed manifest has been obtained from the carrier, and any claim for shortage or damage must be settled between the consignee and the carrier.

**MINIMUM ORDER**

The minimum charge for orders from Multiquip is \$15.00 net. Customers will be asked for instructions regarding handling of orders not meeting this requirement.

**RETURNED GOODS POLICY**

Return shipments will be accepted and credit will be allowed, subject to the following provisions:

1. A Returned Material Authorization must be approved by Multiquip prior to shipment.
2. To obtain a Return Material Authorization, a list must be provided to Multiquip Parts Sales that defines item numbers, quantities, and descriptions of the items to be returned.
  - a. The parts numbers and descriptions must match the current parts price list.
  - b. The list must be typed or computer generated.
  - c. The list must state the reason(s) for the return.
  - d. The list must reference the sales order(s) or invoice(s) under which the items were originally purchased.
  - e. The list must include the name and phone number of the person requesting the RMA.
3. A copy of the Return Material Authorization must accompany the return shipment.
4. Freight is at the sender's expense. All parts must be returned freight prepaid to Multiquip's designated receiving point.
5. Parts must be in new and resalable condition, in the original Multiquip package (if any), and with Multiquip part numbers clearly marked.
6. The following items are not returnable:
  - a. Obsolete parts. (If an item is in the price book and shows as being replaced by another item, it is obsolete.)
  - b. Any parts with a limited shelf life (such as gaskets, seals, "O" rings, and other rubber parts) that were purchased more than six months prior to the return date.
  - c. Any line item with an extended dealer net price of less than \$5.00.
  - d. Special order items.
  - e. Electrical components.
  - f. Paint, chemicals, and lubricants.
  - g. Decals and paper products.
  - h. Items purchased in kits.
7. The sender will be notified of any material received that is not acceptable.
8. Such material will be held for five working days from notification, pending instructions. If a reply is not received within five days, the material will be returned to the sender at his expense.
9. Credit on returned parts will be issued at dealer net price at time of the original purchase, less a 15% restocking charge.
10. In cases where an item is accepted, for which the original purchase document can not be determined, the price will be based on the list price that was effective twelve months prior to the RMA date.
11. Credit issued will be applied to future purchases only.

**PRICING AND REBATES**

Prices are subject to change without prior notice. Price changes are effective on a specific date and all orders received on or after that date will be billed at the revised price. Rebates for price declines and added charges for price increases will not be made for stock on hand at the time of any price change.

Multiquip reserves the right to quote and sell direct to Government agencies, and to Original Equipment Manufacturer accounts who use our products as integral parts of their own products.

**SPECIAL EXPEDITING SERVICE**

A \$35.00 surcharge will be added to the invoice for special handling including bus shipments, insured parcel post or in cases where Multiquip must personally deliver the parts to the carrier.

**LIMITATIONS OF SELLER'S LIABILITY**

Multiquip shall not be liable hereunder for damages in excess of the purchase price of the item with respect to which damages are claimed, and in no event shall Multiquip be liable for loss of profit or good will or for any other special, consequential or incidental damages.

**LIMITATION OF WARRANTIES**

No warranties, express or implied, are made in connection with the sale of parts or trade accessories nor as to any engine not manufactured by Multiquip. Such warranties made in connection with the sale of new, complete units are made exclusively by a statement of warranty packaged with such units, and Multiquip neither assumes nor authorizes any person to assume for it any other obligation or liability whatever in connection with the sale of its products. Apart from such written statement of warranty, there are no warranties, express, implied or statutory, which extend beyond the description of the products on the face hereof.



# OPERATION AND PARTS MANUAL

## HERE'S HOW TO GET HELP

PLEASE HAVE THE MODEL AND SERIAL  
NUMBER *ON-HAND* WHEN CALLING

### UNITED STATES

#### ***Multiquip Corporate Office***

18910 Wilmington Ave. Tel: (800) 421-1244  
Carson, CA 90746 Fax (800) 537-3927  
Contact: mq@multiquip.com

#### ***Mayco Parts***

800-306-2926 Fax: 800-672-7877  
310-537-3700 Fax: 310-637-3284

#### ***Service Department***

800-421-1244 Fax: 310-537-4259  
310-537-3700

#### ***MQ Parts Department***

800-427-1244 Fax: 800-672-7877  
310-537-3700 Fax: 310-637-3284

#### ***Warranty Department***

800-421-1244, Ext. 279 Fax: 310-537-1173  
310-537-3700, Ext. 279

#### ***Technical Assistance***

800-478-1244 Fax: 310-631-5032

### MEXICO

#### ***MQ Cipsa***

Carr. Fed. Mexico-Puebla KM 126.5 Tel: (52) 222-225-9900  
Momoxpan, Cholula, Puebla 72760 Mexico Fax: (52) 222-285-0420  
Contact: pmastretta@cipsa.com.mx

### CANADA

#### ***Multiquip***

4110 Industriel Boul. Tel: (450) 625-2244  
Laval, Quebec, Canada H7L 6V3 Fax: (450) 625-8664  
Contact: jmartin@multiquip.com

### UNITED KINGDOM

#### ***Multiquip (UK) Limited Head Office***

Hanover Mill, Fitzroy Street, Tel: 0161 339 2223  
Ashton-under-Lyne, Fax: 0161 339 3226  
Lancashire OL7 0TL  
Contact: sales@multiquip.co.uk

### BRAZIL

#### ***Multiquip***

Av. Evandro Lins e Silva, 840 - grupo 505 Tel: 011-55-21-3433-9055  
Barra de Tijuca - Rio de Janeiro Fax: 011-55-21-3433-9055  
Contact: cnavarro@multiquip.com.br, srentes@multiquip.com.br

© COPYRIGHT 2007, MULTIQUIP INC.

Multiquip Inc and the MQ logo are registered trademarks of Multiquip Inc. and may not be used, reproduced, or altered without written permission. All other trademarks are the property of their respective owners and used with permission.

This manual MUST accompany the equipment at all times. This manual is considered a permanent part of the equipment and should remain with the unit if resold.

The information and specifications included in this publication were in effect at the time of approval for printing. Illustrations, descriptions, references and technical data contained in this manual are for guidance only and may not be considered as binding. Multiquip Inc. reserves the right to discontinue or change specifications, design or the information published in this publication at any time without notice and without incurring any obligations.

Your Local Dealer is:

