

OPERATION AND PARTS MANUAL



MODEL AR-13HA RIDE-ON TANDEM DRUM ROLLER SERIES DRIVE SYSTEM (HONDA GASOLINE ENGINE)

Revision #2 (07/26/06)

To find the latest revision of this
publication, visit our website at:
www.multiquip.com



THIS MANUAL MUST ACCOMPANY THE EQUIPMENT AT ALL TIMES.



CALIFORNIA — Proposition 65 Warning

Engine exhaust and some of its constituents are known to the State of California to cause cancer, birth defects and other reproductive harm.

MULTIQUIP AR-13HA RIDE-ON TANDEM DRUM ROLLER

Proposition 65 Warning	2
Table Of Contents	4
Parts Ordering Procedures	5
Safety Message Alert Symbols	6-7
Rules For Safe Operation	8-10
Operation and Safety Decals	11-12
Specifications (Roller)	13
Specifications (Engine)	14
Dimensions	15
General Information	16-17
Roller Components	18-20
Engine Components	21
Inspection	22-24
Initial Start-Up	25
Operation	26
Maintenance	27-36
Preparation For Long-Term Storage	37
Manifold Test Ports	38-39
Hydraulic System Diagram	40
Electric Wiring Diagram (S/N 241001 and Below)	41
Electric Wiring Diagram (S/N 241002 and Above)	42
Troubleshooting (Roller)	44
Troubleshooting (Engine)	45-46

COMPONENT DRAWINGS

Explanation Of Code In Remarks Column	48
Suggested Spare Parts	49
Name Plate and Decals	50-51
Front Drum Assembly	52-53
Exciter Assembly	54-55
Rear Drum Assembly	56-57
Covers and Frame Articulation Lock Assy.	58-59
Hood and Rear Panel Assembly	60-61
Steering Column and Hydraulic Artic. Assy.	62-63
Articulation Arm Assembly	64-65
Hydraulic Drive Pump Assembly	66-67
Manifold and Hydraulic Oil Filter Assembly	68-69
Fuel Tank Assembly	70-71
Water Tank Assembly	72-73
Muffler Assembly	74-75
Throttle Assy.	76-77
Brake Control Assy.	78-79
Battery Assy.	80-81
Scraper Assy.	82-83

HONDA GX610K1QZB2 GASOLINE ENGINE

Air Cleaner Assembly	84-85
Carburetor Assembly	86-87
Control Assembly	88-89
Crankcase Cover Assembly	90-91
Camshaft Assembly	92-93
Crankshaft Assembly	94-95
Cylinder Barrel Assembly	96-97
Cylinder Head Assembly	98-99
Fan Cover Assembly	100-101
Fuel Pump Assembly	102-103
Flywheel Assembly	104-105
Ignition Assembly	106-107
Piston Assembly	108-109
Starter Motor Assembly	110-111
Labels Assembly	112-113

Terms and Conditions of Sale	114
------------------------------------	-----

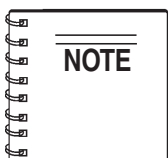

**Specification and part number
are subject to change without
notice.**

www.multiquip.com

**Ordering parts has never been easier!
Choose from three easy options:**



Order via Internet (Dealers Only):

Order parts on-line using Multiquip's SmartEquip website!

- View Parts Diagrams
- Order Parts
- Print Specification Information



If you have an MQ Account, to obtain a Username and Password, E-mail us at: parts@multiquip.com.

To obtain an MQ Account, contact your District Sales Manager for more information.

Goto www.multiquip.com and click on **Order Parts** to log in and save!

Use the **internet** and qualify for a **5% Discount** on *Standard orders* for all orders which include complete part numbers.*

Note: Discounts Are Subject To Change



Order via Fax (Dealers Only):

All customers are welcome to order parts via Fax.

Domestic (US) Customers dial:
1-800-6-PARTS-7 (800-672-7877)

Fax your order in and qualify for a **3% Discount** on *Standard orders* for all orders which include complete part numbers.*

Note: Discounts Are Subject To Change



Order via Phone: Domestic (US) Dealers Call:
1-800-427-1244

Non-Dealer Customers:

Contact your local Multiquip Dealer for parts or call 800-427-1244 for help in locating a dealer near you.



International Customers should contact their local Multiquip Representatives for Parts Ordering information.

When ordering parts, please supply:

- | | |
|------------------------------------------------------------------------------------------------------------------------------------------------------------------------------------------------------------------------------------------------------------------------------------------------------------------------------------------------------------------------------------------------------------------------------------------------------|----------------------------------------------------------------------------------------------------------------------------------------------------------------------------------------------------------------------------------------------------------------------------------------------------------------------------------------------------------------------------------------------------------------------------------------------------------------------------------------------------------------|
| <ul style="list-style-type: none"> <input type="checkbox"/> Dealer Account Number <input type="checkbox"/> Dealer Name and Address <input type="checkbox"/> Shipping Address (if different than billing address) <input type="checkbox"/> Return Fax Number <input type="checkbox"/> Applicable Model Number <input type="checkbox"/> Quantity, Part Number and Description of Each Part | <ul style="list-style-type: none"> <input type="checkbox"/> Specify Preferred Method of Shipment: <ul style="list-style-type: none"> <input checked="" type="checkbox"/> Fed Ex/UPS <input checked="" type="checkbox"/> DHL <input type="checkbox"/> Priority One <input checked="" type="checkbox"/> Truck <input type="checkbox"/> Ground <input type="checkbox"/> Next Day <input type="checkbox"/> Second/Third Day |
|------------------------------------------------------------------------------------------------------------------------------------------------------------------------------------------------------------------------------------------------------------------------------------------------------------------------------------------------------------------------------------------------------------------------------------------------------|----------------------------------------------------------------------------------------------------------------------------------------------------------------------------------------------------------------------------------------------------------------------------------------------------------------------------------------------------------------------------------------------------------------------------------------------------------------------------------------------------------------|

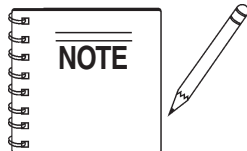

Unless otherwise indicated by customer, all orders are treated as *Standard Orders* and will ship within 24 hours. We will make every effort to ship *Air Shipments* the same day the order is received, if received prior to 2PM PST. *Stock Orders* must be noted on fax or web order form.

WE ACCEPT ALL MAJOR CREDIT CARDS!



AR-13HA RIDE-ON ROLLER — SAFETY MESSAGE ALERT SYMBOLS

FOR YOUR SAFETY AND THE SAFETY OF OTHERS!

Safety precautions should be followed at all times when operating this equipment. Failure to read and understand the Safety Messages and Operating Instructions could result in injury to yourself and others.

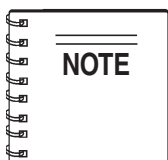

This Owner's Manual has been developed to provide complete instructions for the safe and efficient operation of the Multiquip Model AR-13HA Ride-on Tandem Drum

Roller. Refer to the engine manufacturers instructions for data relative to its safe operation.

Before using this roller, ensure that the operating individual has read and understands all instructions in this manual.

SAFETY MESSAGE ALERT SYMBOLS

The three (3) Safety Messages shown below will inform you about potential hazards that could injure you or others. The Safety Messages specifically address the level of exposure to the operator, and are preceded by one of three words: **DANGER**, **WARNING**, or **CAUTION**.

DANGER

You **WILL** be **KILLED** or **SERIOUSLY** injured if you do not follow directions.

WARNING

You **COULD** be **KILLED** or **SERIOUSLY** injured if you do not follow directions.

CAUTION

You **CAN** be injured if you do not follow directions

HAZARD SYMBOLS

Potential hazards associated with operation of the pump will be referenced with Hazard Symbols which appear throughout this manual, and will be referenced in conjunction with Safety Message Alert Symbols. Some examples are listed below:

WARNING - LETHAL EXHAUST GASES



Gasoline engine exhaust gases contain poisonous carbon monoxide. This gas is colorless and odorless, and can cause death if inhaled. **NEVER** operate this equipment in a confined area or enclosed structure that does not provide ample free flow air.

WARNING - EXPLOSIVE FUEL



Gasoline is extremely flammable, and its vapors can cause an explosion if ignited. **DO NOT** start the engine near spilled fuel or combustible fluids. **DO NOT** fill the fuel tank while the engine is running or hot.

DO NOT overfill tank, since spilled fuel could ignite if it comes into contact with hot engine parts or sparks from the ignition system. Store fuel in approved containers, in well-ventilated areas and away from sparks and flames. **NEVER** use fuel as a cleaning agent.

WARNING - BURN HAZARDS



Engine components can generate extreme heat. To prevent burns, **DO NOT** touch these areas while the engine is running or immediately after operations. **NEVER** operate the engine with heat shields or heat guards removed.

AR-13HA RIDE-ON ROLLER — SAFETY MESSAGE ALERT SYMBOLS

WARNING - ROTATING PARTS



NEVER operate equipment with covers, or guards removed. Keep **fingers, hands, hair** and clothing away from all moving parts to prevent injury.

CAUTION - RESPIRATORY HAZARDS



ALWAYS wear approved **respiratory** protection.

CAUTION - ACCIDENTAL STARTING



ALWAYS place the **Engine ON/OFF** switch in the **OFF** position and remove the ignition key when the pump is not in use.

CAUTION - SIGHT AND HEARING HAZARDS

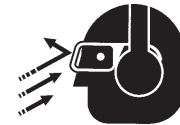

ALWAYS wear approved **eye** and **hearing** protection.

CAUTION - OVER-SPEED CONDITIONS



NEVER tamper with the factory settings of the engine governor or settings. Personal injury and damage to the engine or equipment can result if operating in speed ranges above maximum allowable.

CAUTION - EQUIPMENT DAMAGE MESSAGES

Other important messages are provided throughout this manual to help prevent damage to your concrete pump, other property, or the surrounding environment.

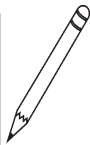
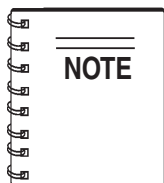

This Ride-on Tandem Drum Roller, other property, or the surrounding environment could be damaged if you do not follow instructions.

RULES FOR SAFE OPERATION

DANGER - Read This Manual!

Failure to follow instructions in this manual may lead to serious injury or even **DEATH!** This equipment is to be operated by trained and qualified personnel only! This equipment is for industrial use only.

The following safety guidelines should always be used when operating the AR-13HA Ride-on Tandem Drum Roller:

GENERAL SAFETY

- **DO NOT** operate or service this equipment before reading this entire manual.
- This equipment should not be operated by persons under 18 years of age.
- **NEVER** operate this equipment without proper protective clothing, shatterproof glasses, steel-toed boots and other protective devices required by the job.
- **NEVER** operate this equipment when not feeling well due to fatigue, illness or taking medicine.
- **NEVER** operate this equipment under the influence of drugs or alcohol.
- Whenever necessary, replace nameplate, operation and safety decals when they become difficult read.
- **ALWAYS** check the machine for loosened threads or bolts before starting.
- **ALWAYS** wear proper respiratory (mask) hearing and eye protection equipment when operating the roller.



- **NEVER** operate this equipment when not feeling well due to fatigue, illness or taking medicine.
- **NEVER** operate this equipment under the influence of **drugs** or **alcohol**.



- **NEVER** touch the hot exhaust manifold, muffler or cylinder. Allow these parts to cool before servicing engine or pump.

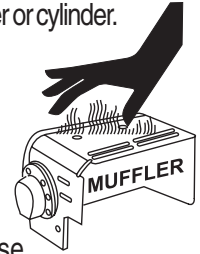

- **High Temperatures** – Allow the engine to cool before adding fuel or performing service and maintenance functions. Contact with *hot* components can cause serious burns.

- The engine of this roller requires an adequate free flow of cooling air. Never operate the roller in any enclosed or narrow area where free flow of the air is restricted. If the air flow is restricted it will cause serious damage to the roller or engine and may cause injury to people and property. Remember the roller's engine gives off **DEADLY** gases.

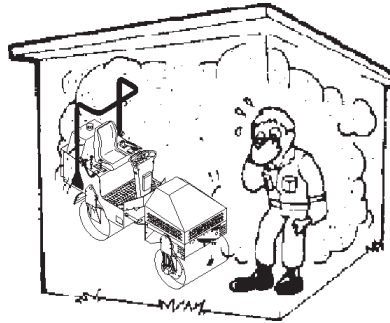

- **ALWAYS** refuel in a well-ventilated area, away from sparks and open flames.
- **ALWAYS** use extreme caution when working with **flammable** liquids. When refueling, **stop the engine** and allow it to cool. **DO NOT** smoke around or near the machine. Fire or explosion could result from fuel vapors, or if fuel is spilled on a hot engine.
- **NEVER** operate the Ride-on Tandem Drum Roller in an explosive atmosphere or near combustible materials. An explosion or fire could result causing severe *bodily harm or even death*.
- Topping-off to filler port is dangerous, as it tends to spill fuel.
- Refer to the **Engine Owner's Manual** for engine technical questions or information.
- **NEVER** use accessories or attachments, which are not recommended by Multiquip for this equipment. Damage to the equipment and/or injury to user may result.
- Manufacturer does not assume responsibility for any accident due to equipment modifications.

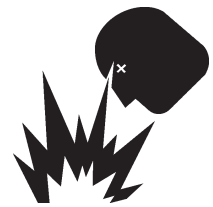

RULES FOR SAFE OPERATION

- **NEVER** Run engine without air cleaner. Severe engine damage may occur.
- **ALWAYS** read, understand, and follow procedures in Operator's Manual before attempting to operate equipment.
- **ALWAYS** be sure the operator is familiar with proper safety precautions and operations techniques before using roller.
- **ALWAYS** store equipment properly when it is not being used. Equipment should be stored in a clean, dry location out of the reach of children.
- **DO NOT** operate this roller with hydrostatic oil temperature higher than 180 degrees fahrenheit.
- **NEVER** leave the roller unattended, turn off engine and place parking brake lever in upright position.
- **CAUTION** must always be observed while servicing this roller. Rotating parts can cause injury if contacted.
- **DO NOT** leave roller with engine running.
- If the roller must be stopped on an incline (grade), remove the ignition key and place chock blocks (not provided) under **the front** and **rear** drums.
- **NEVER** drive the roller on unshored trenches or near steep, unsupported banks. The vibration caused by the roller could cause a cave-in.
- **ALWAYS** use extreme care when operating near obstructions, on slippery surfaces, grades and side slopes.
- **ALWAYS** wear slip resistant safety shoes or boots.
- Unauthorized equipment modifications will void all warranties.
- When working on slopes, avoid **sidehill travel**. Operate up and down travel only. Remember, the danger of sliding on and/or tripping on steep slopes is always present.
- **ALWAYS** wear **seat belts**.
- When malfunctions occur, always remove the ignition key and place a "**DO NOT OPERATE**" sign in the operator's seat.
- If a malfunction occurs with the travel lever mechanism, speed and direction will be impossible to control. Immediately stop the roller and correct the problem.
- If the steering system operates improperly, immediately stop the engine and apply the parking brake.
- In the event of hydraulic hose or line failure, promptly return the travel lever to the "neutral" position, stop the engine and set the parking brake.

MAINTENANCE SAFETY

- **NEVER** lubricate components or attempt service on a running machine.
- **ALWAYS** allow the machine a proper amount of time to cool before servicing.
- Keep the machinery in proper running condition.
- Fix damage to the machine immediately and always replace broken parts, or missing decals.
- Dispose of hazardous waste properly. Examples of potentially hazardous waste are used motor oil, fuel and fuel filters.
- **DO NOT** use food or plastic containers to dispose of hazardous waste.
- **DO NOT** pour waste, oil or fuel directly onto the ground, down a drain or into any water source.

RULES FOR SAFE OPERATION

LOADING AND TRANSPORTING SAFETY

DANGER - Loading & Unloading the Roller

DANGER! ALWAYS load and unload the roller on **Level, Hard Ground, or Pavement**. **Serious injury or death** can result from improper loading, lifting or unloading. Use extreme caution!

- The roller has an operating weight of approximately 3,088 lbs. (1,400 Kg). Use lifting equipment capable of lifting this weight.
- **ALWAYS** check the roller's lifting hooks. Before lifting or transporting the roller, lock the frame with the locking bar that is provided. Make sure the hooks are secure and tight before lifting the machine.
- When driving the roller onto a transporting vehicle or trailer, use ramps or other suitable material of sufficient strength to support the roller.
- Remove mud, oil, ice, snow or any other slippery materials from the ramps and bed of the vehicle to avoid accidents.
- After loading, apply the parking brake.
- Use a chain, binders or other suitable means to firmly secure the roller before transporting.
- Only use the lifting points for the roller that are clearly marked as "**lifting point**".
- **NEVER** apply chains through the articulating section of the roller. The chain could cause damage by scoring the hydraulic steering cylinder.
- **NEVER** stand below roller when it is being lifted.

DANGER - Transporting Safety

DO NOT allow personnel to **stand under** or **near** any suspended machine. **Serious injury or death** may result.

EMERGENCIES

- **ALWAYS** know the location of the nearest **fire extinguisher**.



- **ALWAYS** know the location of the nearest and **first aid kit**.



- In emergencies **always** know the location of the nearest phone or **keep a phone on the job site**. Also know the phone numbers of the nearest **ambulance, doctor** and **fire department**. This information will be invaluable in the case of an emergency.

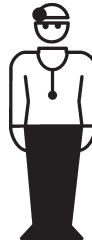

OPERATION AND SAFETY DECALS

Machine Safety Decals

The AR-13HA Ride-on Tandem Drum Roller is equipped with a number of safety decals. These decals are provided for operator safety and maintenance information. The illustration below and on the next page shows these decals as they appear on the machine. Should any of these decals become unreadable, replacements can be obtained from your dealer.



P/N: 345336



P/N: 511735

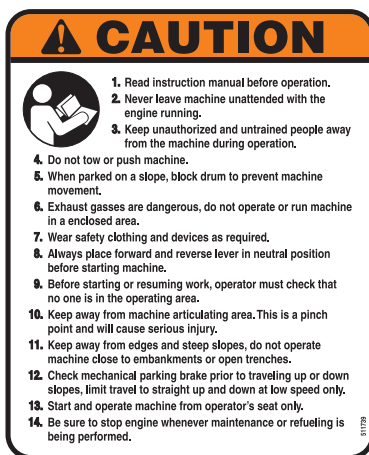

P/N: 511739

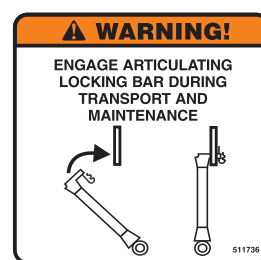

P/N: 511736



P/N: 511738

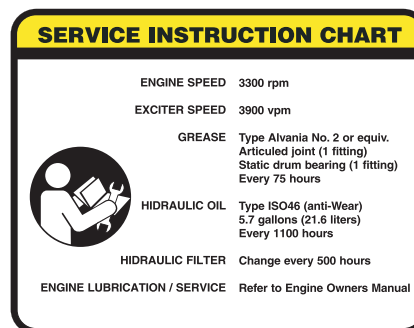

P/N: 511737



P/N: 513740



P/N: 515642



P/N: 513469



P/N: 515643

MQ MULTIQUIP

P/N: TBD



P/N: 511724



P/N: 511726



P/N: 513688



P/N: 511733



P/N: 511718

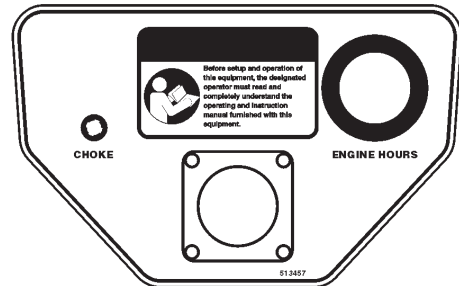

P/N: 513457

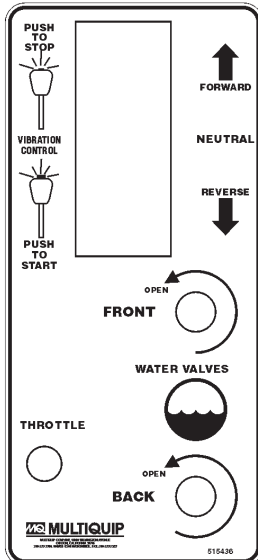

P/N: 515436



P/N: 513393

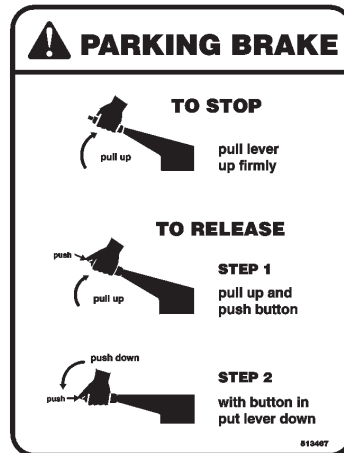

P/N: 513467

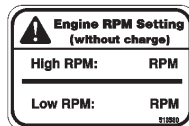

P/N: 513580

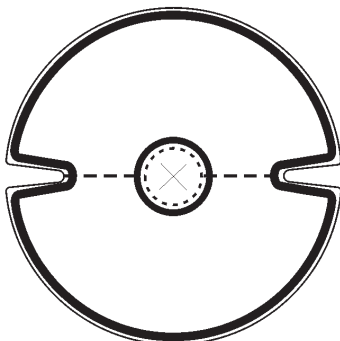

P/N: 513698

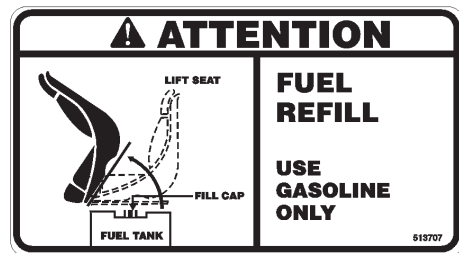

P/N: 513707

AR-13HA RIDE-ON ROLLER — SPECIFICATIONS (ROLLER)

Table 1. AR-13HA Roller Specifications

Shipping Weight	2,572 lbs. (1,167 Kg.)
Dry Weight	2,428 lbs. (1101 Kg.)
Operating Weight	3,088 lbs. (1,400 Kg.)
Operating Weight w/ Drum Ballast	3,309 lbs. (1,500 Kg.)
Overall Length	86.5 in. (2,197 mm.)
Overall Width	38.25 in. (972 mm.)
Overall Height-ROPS (up)	87 in.(2210 mm.)
Maximum Rolling Width	35.7 in. (907 cm.)
Turning Radius-Inside	109 in. (2,768 mm.)
Ground Clearance	11.5 in. (292 mm.)
Curb Clearance	7.75L, 19.0R (197 mm., 483 mm.)
Wall Clearance	1.75L, 1.25R (45 mm., 32 mm.)
Wheelbase	45 in. (1,143 mm.)
Drum Width	35.7 in. (907mm.)
Drum Diameter	22.6 in. (574 mm.)
Drum Thickness	0.38 in. (10.0 mm.)
Centrifugal Force 2,400 - 2,700 rpm	3,100 Lbs. (1,406 Kg.)
Vibrations per minute 2,400 - 2,700 rpm	4,000 VPM
Dynamic Linear Force per Drum 2,400 - 2,700 rpm	87.5 Lbs./in. (39.6 Kg./cm.) (front only)
Oscillating Angle	11 degrees
Hydraulic Oil Tank Capacity	5.7 U.S. Gallons (21.6 Liters)
Cooling System	Air
Fuel	Gasoline
Fuel Tank Capacity	9.5 U.S. Gallons (36 Liters)
Water Tank Capacity	60 Gallons (227 Liters)
Battery	12 Volt GroupType U1
Travel Speed -variable-	0-4.8 MPH (0-7.7 KPH)
Grade Ability w-w/o Vibration	15 degrees (27%)

AR-13HA RIDE-ON ROLLER — SPECIFICATIONS (ENGINE)

Table 2. Engine Specifications

Model	Honda GX610K1QZB2 Engine
Type	Air-Cooled 4 Stroke, Overhead Valve, 2 cylinders (90 degree V-Twin), Gasoline Engine.
Piston Displacement	37.5 cu. in. (614 cc)
[Bore x Stroke]	[3.03 in. x 2.60 in. (77 mm x 66 mm)]
Max. Output	18 hp (13.4 KW, 18.3 PS) at 3,600 rpm
Max. Governed Speed, No Load	3,500 rpm
Max. Torque	31.8 lbf-ft. at 2,500 rpm
Cooling System	Forced Air
Engine Oil	SAE-10W-30 for general use
Engine Oil Capacity (with oil filter replacement)	1.90 qts. (1.80 liters)
Engine Oil Capacity (without oil filter replacement)	1.59 qts. (1.50 liters)
Fuel	Unleaded gasoline
Fuel Consumption	0.51 lb/hph (313 g/kWh, 230 g/PSH)
Spark Plug Type	NGK: ZGR5A DENSO: J16CR-U
Idle Speed	1,400 +/- 150 rpm
PTO Shaft Rotation	Counterclockwise

AR-13HA RIDE-ON ROLLER — DIMENSIONS

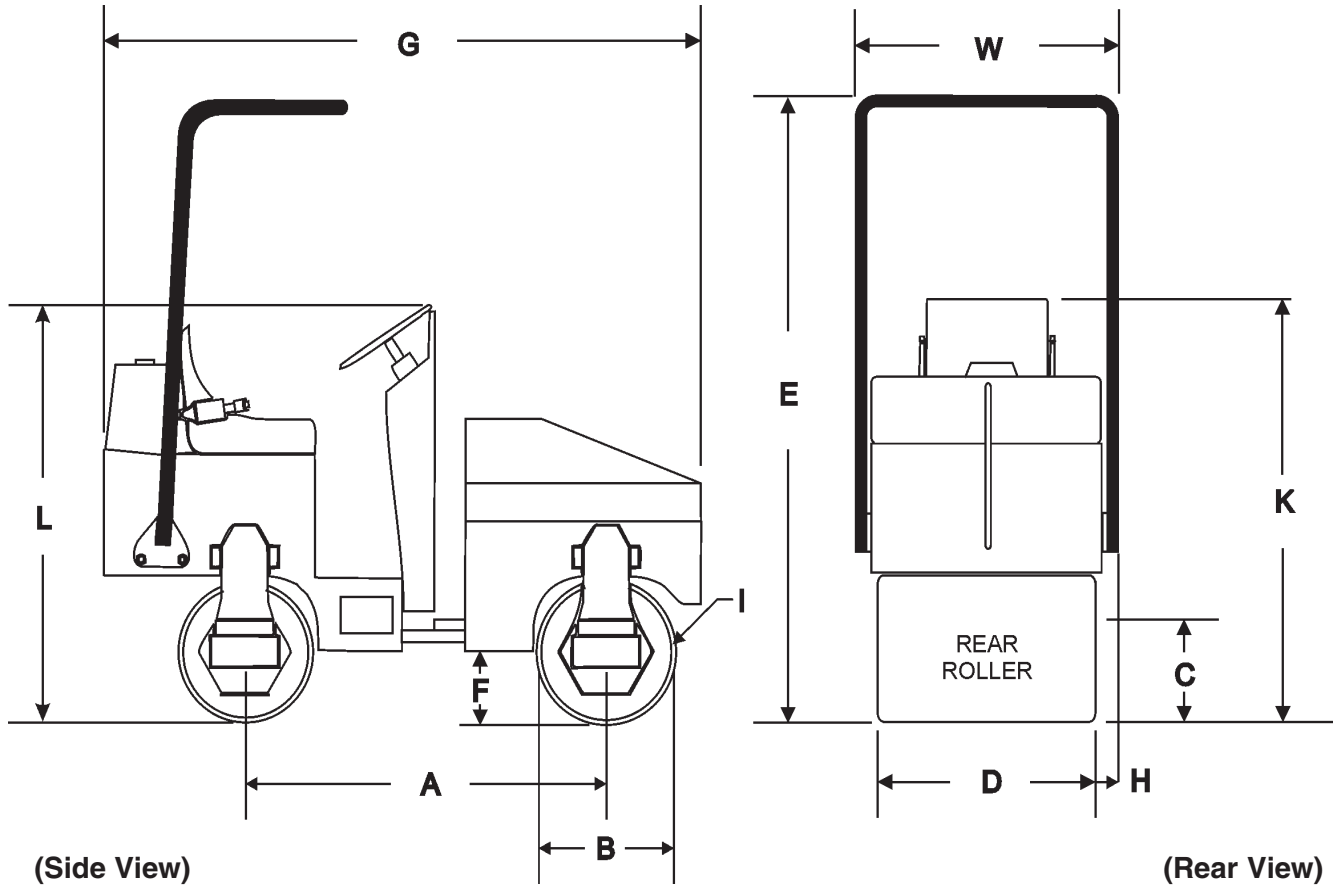

Figure 1. AR-13H Roller Dimensions

Table 3. AR-13 Dimensions		
Wheelbase	A	45.0 in. (1,143 mm.)
Drum Diameter	B	22.6 in. (574 mm.)
Curb Clearance	C	7.75 in. Left, 19.0 in. Right (197 mm., 483 mm.)
Drum Width	D	35.7 in. (907 mm.)
Overall Height (with ROPS)	E	87 in. (2,210 mm.)
Ground Clearance	F	11.5 in. (292 mm.)
Overall Length	G	86.5 in. (2,147 mm.)
Wall Clearance	H	1.75 in. Left, 1.25 in. Right (45 mm., 32 mm.)
Drum Thickness	I	.38 in. (10 mm.)
Overall Width	J	38.25 in. (972 mm.)
Seat Height	K	63 in. (1,600 mm.)
Steering Wheel	L	60 in. (1,524 mm.)

AR-13HA RIDE-ON ROLLER — GENERAL INFORMATION

The AR-13H roller has been designed for asphalt application and compaction of granular soils used in site preparation. Use the machine only for the purpose intended and by experienced personnel who understand this operating manual and all safety decals. Typical applications for this roller are driveways, patch work and road repairs. Standard features included with this roller are articulated steering, double drum hydrostatic drive, front drum vibration, high curb clearance and on board water capability.

POWER PLANT

The AR-13H roller is powered by a Honda GX-610, air cooled, gasoline engine rated at 18 hp @3,500 rpm. The engine features a side-mounted muffler designed to direct engine exhaust away from the operator. In the event of low oil, this engine has a built in "**oil alert system**" that will shut-down if the engine oil level reaches an unsafe operating level.

HYDRAULIC SYSTEM

The Honda GX-610 engine drives an axial hydraulics, variable displacement pump which is manually controlled via a cable control system. Pump flow is directed through an aluminum block manifold which provides the control for the 3 hydraulic motors.

The hydraulic drum drive system incorporates a parallel closed loop configuration operating at a maximum pressure of 2,900 psi. In addition this hydraulic system offers a "**free wheel valve**" which allows the roller to be towed in the event of an emergency.

COMPACTION SYSTEM

The compaction force is delivered by a 36-inch wide steel drum with beveled edges to help prevent asphalt **marring**. A fully enclosed hydrostatic drive system offers a variable speed control as well as smooth acceleration and braking.

Connected to the axial hydraulic pump is a gear pump that provides power for the drum vibratory system and the articulating steering system. Oil from this pump flows to the manifold control valve block and then to a hydraulic motor which rotates the eccentric weights inside a sealed housing containing oil to lubricate the bearings.

A pushbutton switch located on top of the gearshift lever when pressed activates a **hydraforce** valve that engages or disengages the vibratory action. The drum's vibratory action generates 3,100 lbs. (1,406 Kg.) of centrifugal force at a frequency of 4,000 vpm (vibrations per minute). If the vibration appears to be weak or slow, allow the machine to warm-up thoroughly, and check the hydraulic oil level. Add hydraulic oil if necessary.

The vibrator housing and drum are shock mounted to isolate the engine compartment and operator from vibration.

The roller nominally has an operating weight of 3,088 lbs (1,400 Kg.), but can be increased to 3,309 lbs (1,500 Kg.) by adding water ballast to the rear drum.

HYDRAULIC OIL FILTER SYSTEM

The hydraulic system oil is filtered by a screen type filter located in the reservoir filler neck, then doubled filtered within the system first by a 40 micron mesh-type suction filter located in the tank and the by a **Zinga** 10 micron, cartridge style spin-on return line filter.

ARTICULATED STEERING SYSTEM

Power for the articulated steering system, which uses a single hydraulic cylinder is provided by the gear pump. This steering system can produce an inside turning radius of 109 inches (2.77 meters).

SPRINKLER SYSTEM

A 60 gallon (227 liters) water tank with a gravity feed spray bar is provided for wetting the roll for asphaltic pavement rolling.

The water system is fully adjustable from the operator's position by adjusting the two water valves. The front valve controls the water supply to the front drum, and the rear valve controls water to the rear drum.

Before starting an asphalt rolling job, be sure all spray bar holes are clear of dirt or foreign matter and are working. Always use clean fresh water in the water tank. To prevent rust and foreign debris from clogging the spray bar holes, drain and flush water tank and spray bars every 30 days.

LIFTING THE ROLLER

When lifting of the roller is required, attach a suitable hook or shackle to the **lifting eye** of the roller. These lifting points (4) are marked by a lifting hook decal. Make sure the lifting device is capable of lifting 4,000 lbs. (1,814 Kg).



DANGER - Clear Obstacles from Area

Before operating the roller, make sure that personnel and obstacles are free from the roller's path. **Serious injury** or even **death** can result!

The forward-reverse control lever operates the hydrostatic pump which governs the roller speed and direction of travel. The speed in which movement of this lever is made is directly related to the amount of pressure that is applied to the travel lever in each direction. Travel speed is infinitely variable from 0 to 4.8 mph. The neutral position of this lever will cause the roller to stop.

AR-13HA RIDE-ON ROLLER — GENERAL INFORMATION

! DANGER - Transporting Safety

DO NOT allow personnel to **stand under** or **near** any suspended machine. **Serious injury** or **death** may result.

! CAUTION - Use CERTIFIED Lifting Devices

ONLY! use approved certified lifting devices capable of lifting at least 4,000 lbs. (1,814 Kg.).

! CAUTION - Lifting the Roller

When lifting of the roller is required, only use the provided **lifting eyes** to lift the roller. Using other sections of the roller for lifting purposes may cause severe damage to the roller.

OPERATING ON SLOPES

Special care must be taken when operating the roller on hills or slopes. There exist the possibility of serious injury to the operator and severe damage to the roller in the event of a roll over. **ALWAYS** operate the roller up and down hills rather than from side to side. For safe operation hillside slopes should not exceed 12 degree (27 % grade). See Figure 2 below.

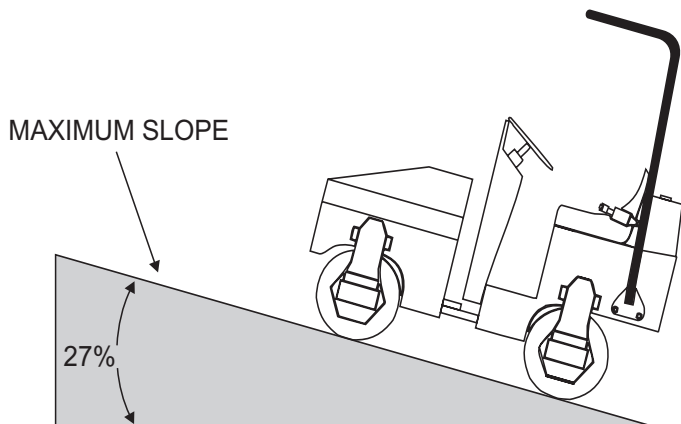

Figure 2. Recommend Slope

Tipping (Rollovers)

NEVER! operate the roller on side slopes (Figure 3). The possibility exist that the roller could tip over (roll over), thus causing bodily harm even death and serious damage to the equipment.

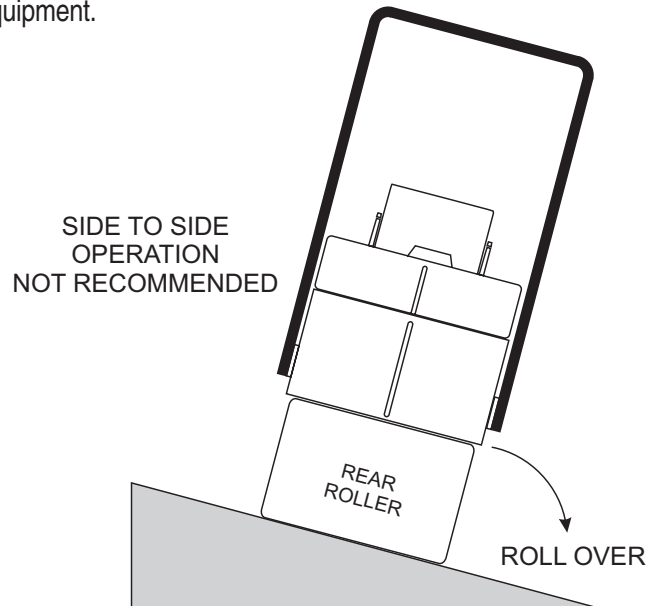
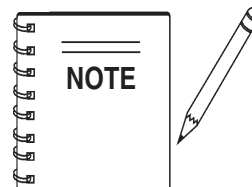

Figure 3. Tipping (Rollover)



NEVER! operate the roller on **side slopes**. The roller may tip over causing injury to personnel and severe damage to the equipment

In the event the roller does tip over, if at all possible, try to shut-down the engine by turning the ignition key to the **OFF** position. Extreme care must be taken to prevent damage to the engine. When the roller has been tipped over, oil from the engine crankcase can flow into the combustion chamber, which can severely damage the engine the next time it is started.

IMMEDIATELY after a unit has tipped over upright the unit as soon as possible to prevent oil from leaking into the combustion chamber.

! CAUTION - Roller Rollover Safety

To prevent damage to the engine after a rollover, the roller must **NOT** be started. **NEVER** start a roller after a rollover. **CONTACT** your nearest authorized multiquip dealer for instructions or servicing.

AR-13HA RIDE-ON ROLLER — ROLLER COMPONENTS

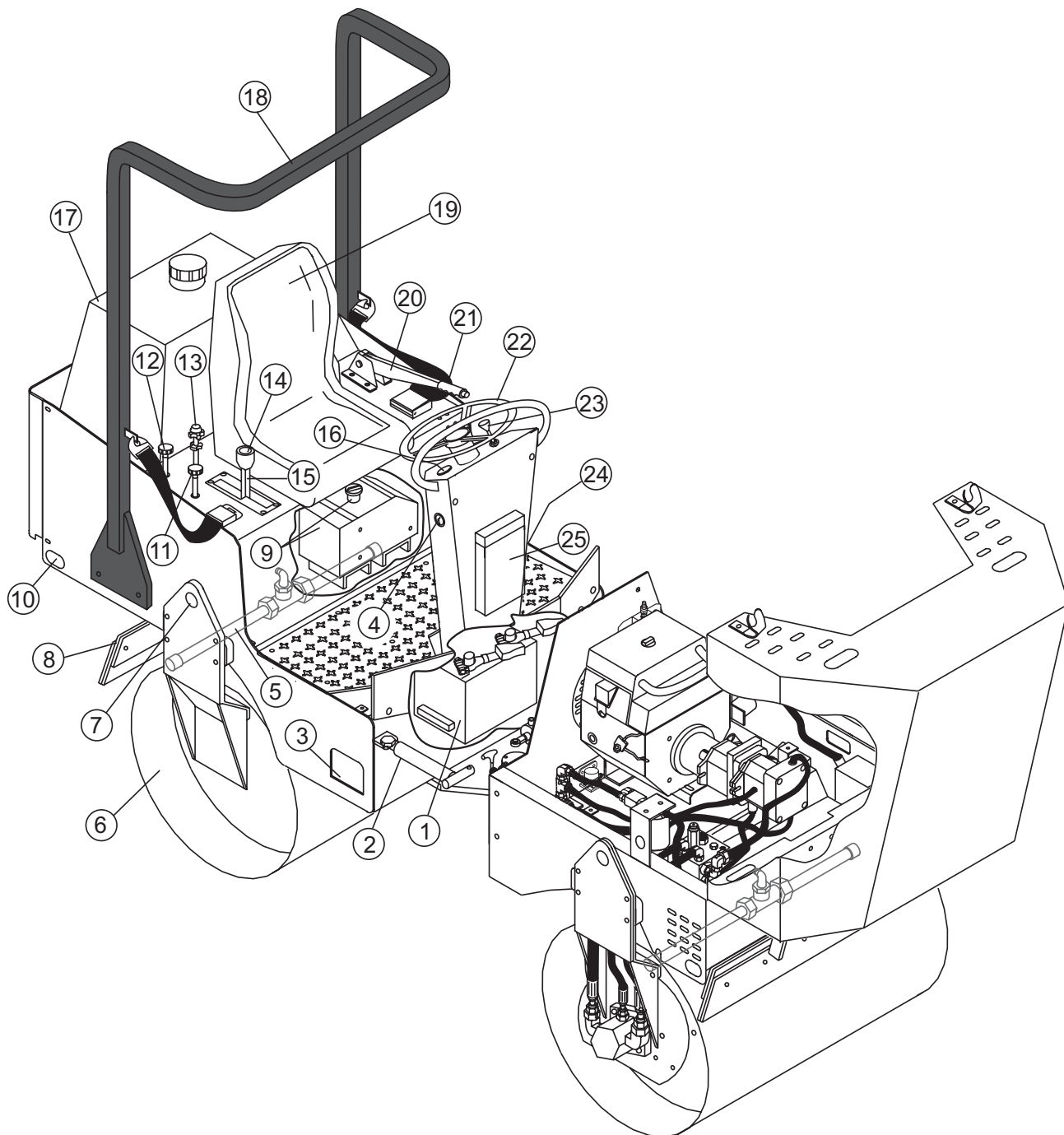
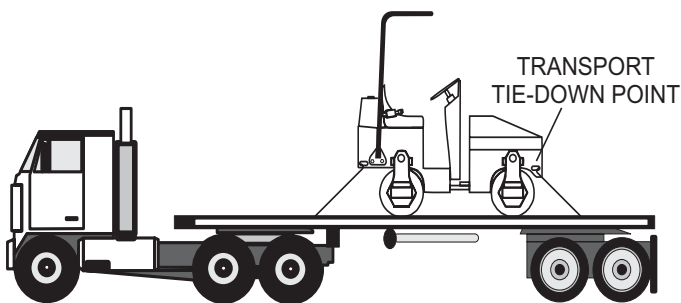

Figure 4. Roller Components 1

AR-13HA RIDE-ON ROLLER — ROLLER COMPONENTS

Figure 4 shows the location of the components and basic components for the AR-13HA compaction roller. The function of each component or control is described below:

1. **Battery** – Provides +12VDC to the electrical system, and is located underneath foot plate. Replace only with recommended type battery, see specification Table 1.
2. **Articulating Locking Bar** – Always make sure that the articulating locking bar is engaged during lifting, transport and maintenance.
3. **Foot Step** – To lift yourself onto the roller's platform, place foot into foot step, then grab hold of hand rail.
4. **Ignition Switch** – With key inserted, turn clockwise to start the engine.
5. **Rear Sprinkler System** – A gravity feed spray bar is provided for the wetting the roll for asphalt pavement.
6. **Rear Roller** – This roller is a 30 inch wide **steel drum** with beveled edges (no vibration). The beveled edges help prevent asphalt marring.
7. **Lifting Point** – Attach a crane or suitable lifting device to this point when lifting of the roller is required.
8. **Rear Scrapper** – This adjustable rear scrapper blade helps prevent the buildup of material between the drum and frame.
9. **Fuel Tank/Fuel Gauge** – The fuel capacity of the fuel tank is 9.5 gallons (36 liters). Read the gauge on top of the fuel cap to determine if fuel level is low. Fill with unleaded type gasoline. To gain access to the fuel tank, **tilt the front seat forward**. Fuel tank has a spill containment feature
10. **Tie-Down Transport Point** – Attach a chain or suitable tie-down device to this point when transporting of the is required.



11. **Front Spray Control Valve** – This valve controls the flow of water to the **front spray bar**. Turn the water valve to the **open** position (counterclockwise) to let water flow, return this valve to the **closed** position (clockwise) when water is not required.

12. **Rear Spray Control Valve** – This valve controls the flow of water to the **rear spray bar**. Turn the water valve to the **open** position (counterclockwise) to let water flow, return this valve to the **closed** position (clockwise) when water is not required.
13. **Throttle Control** — Pull all the way out to achieved maximum engine RPM's. To idle the engine, push the **RED** stop button inwards all the way.
14. **Vibration Control Button** – Press this button to activate the eccentric that will produce a vibration frequency of 4,400 vpm (vibrations per minute). Pressing the button again will stop the vibrations.
15. **Shift Lever** — Push the lever **forward** to makethe roller travel in a forward direction, pull the lever **backward** to make the roller travel in a reverse direction. Maximum travel speed is 4.8 MPH (7.7 KPH). Center position is neutral, no travel.
16. **Hourmeter** — Indicates the number hours the unit has been in use.
17. **Water Tank** — Remove filler cap and fill with water. Water tank capacity is 60 gallons (227 liters). To determine if water level is low, visually inspect water level gauge (tube) at rear of roller. Add water as necessary.
18. **Roll-Over Bar** — This unit may be equipped with a **Roll Over Protection System** (ROPS option) to protect the operator when the roller is used on slopes, open trenches, sharp turns, slippery surfaces or objects in the rollers's path of travel.
19. **Operator's Seat** — A contoured seat that provides visibility of both front rear drum edges during operation. **NEVER!** start the roller unless seated in the operator's seat.
20. **Parking Break Lever** — Pull the lever upward to set the parking break. To release the parking break, press and hold the button on top of the lever and push lever downward.
21. **Seat Belt** — When using the roller in working conditions always have the operator wear the seat belt. **NEVER** use the roller without a seat belt. If the seat belt becomes worn or damaged, have it replaced immediately.
22. **Steering Wheel** — Use this wheel to steer the roller.
23. **Choke Knob** — Used in the starting of a cold engine, or in cold weather conditions. The choke enriches the fuel mixture.
24. **Hydraulic Motor** – This hydraulic motor provides control for the **rear** of the roller
25. **Documentation Box** — Maintain and store **at all times** Operation, Parts, and Engine manuals in this box.

AR-13HA RIDE-ON ROLLER — ROLLER COMPONENTS

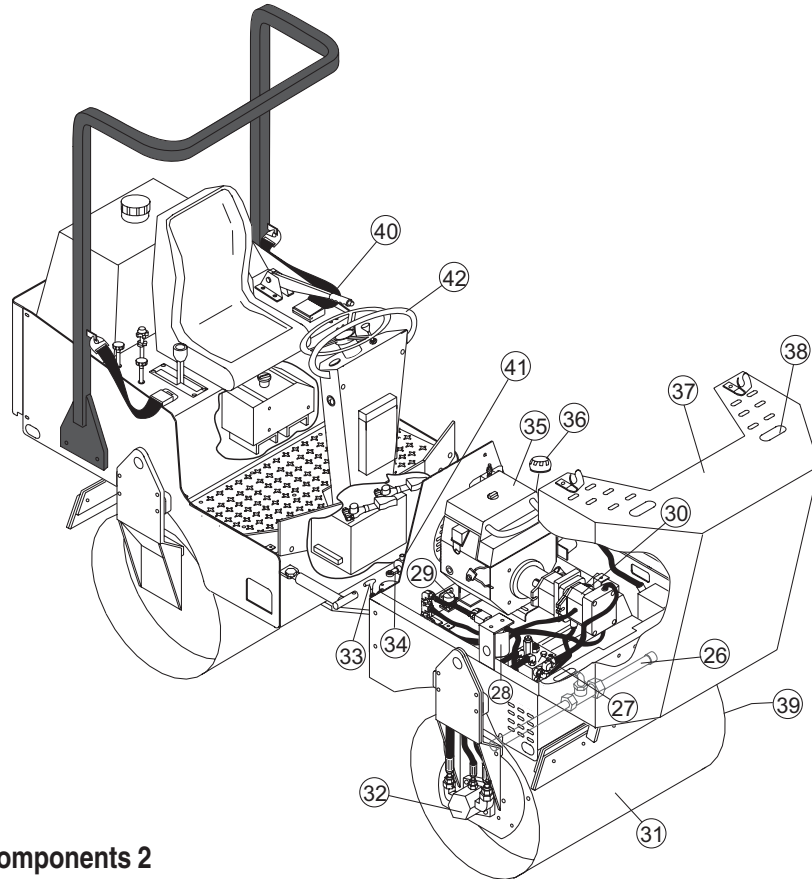

Figure 5. Roller Components 2

Figure 5 shows the location of additional components for the AR-13HA compaction roller. The function of each component or control is described below:

- 26. **Front Sprinkler System** – A gravity feed spray bar is provided for the wetting the roll for asphalt pavement.
- 27. **Hydraulic Manifold** – Aluminum block that controls the flow of hydraulic pressure to the various hydraulic motors and other components required to control the roller.
- 28. **Hydraulic Oil Filter** – Filters return oil from the front and rear hydrostatic motors.
- 29. **Accessory Relay** – Provides the +12VDC necessary to run the roller's electrical accessories.
- 30. **Hydraulic Pump** – This unit incorporates an axial variable displacement hydraulic piston pump.
- 31. **Front Ride-on Tandem Drum Roller** – This roller is a 30 inch wide **steel drum** with beveled edges. The beveled edges help prevent asphalt marring.
- 32. **Hydraulic Motor** – This hydraulic motor controls the rotation of the vibratory system.
- 33. **Bunjee Latch** – Pull this rubber latch upward and back to gain access to the engine/pump compartment. There is one rubber latch located on each side of the unit.
- 34. **Steering Cylinder** – Controls direction of roller.
- 35. **Engine** – This unit incorporates a HONDA GX-610, air cooled engine rated at 18 hp at 3,500 rpm.
- 36. **Hydraulic Fluid Filler Port** – Remove this cap to add hydraulic fluid. Fill with type ISO 46 anti-wear hydraulic fluid.
- 37. **Compartment Hood** – Houses the engine, hydraulic manifold, accessory relay, hydraulic oil filter, hoses, and hydraulic pump. To lift the compartment hood, release the rubber bunjee latches located on each side of the hood.
- 38. **Compartment Hood Lift Point** – Place hand here then lift upwards to lift compartment hood.
- 39. **Hydraulic Motor** – This hydraulic motor drives the roller during operation.
- 40. **Rear Drum Zerk Grease Fitting** – Grease this fitting bi-weekly. See maintenance section of this manual.
- 41. **Articulation Zerk Grease Fitting** – Grease this fitting once a year. See maintenance section of this manual.
- 42. **Hand Rail** – Grab hold of this hand rail when lifting yourself onto the operator's platform.

AR-13HA RIDE-ON ROLLER — ENGINE COMPONENTS

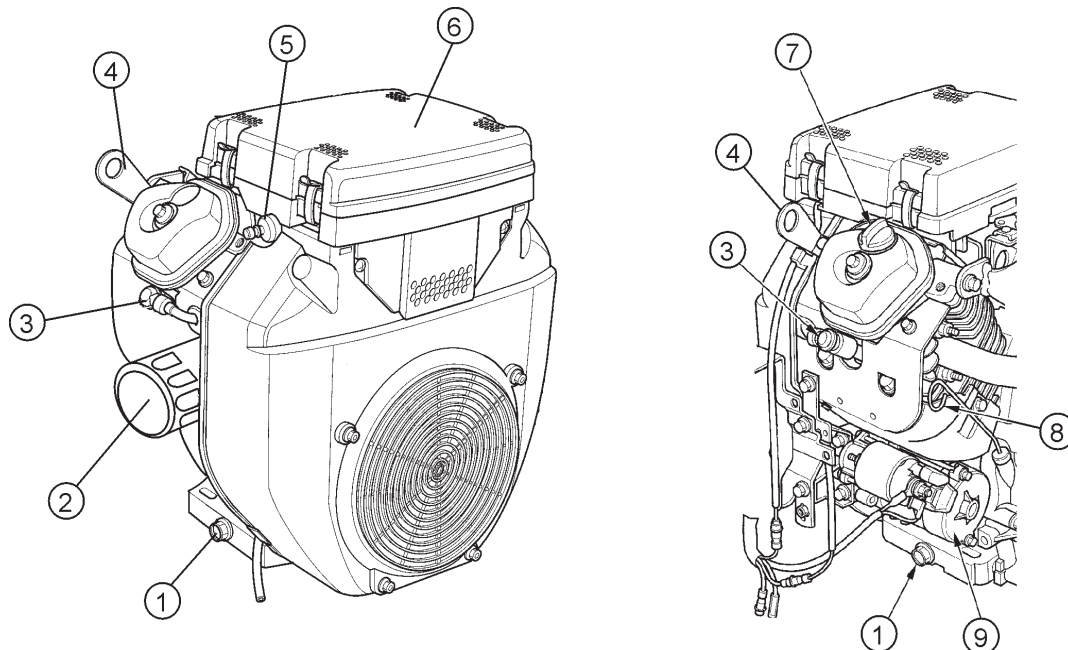

Figure 6. Honda GX610 Engine Controls and Components

INITIAL SERVICING

The engine (Figure 6) must be checked for proper lubrication and filled with fuel prior to operation. Refer to the manufacturer's engine manual for instructions & details of operation and servicing.

1. **Oil Drain Plug** – Remove to drain crankcase oil. Fill with recommended type oil as listed in Table 4.
2. **Oil Filter** – Spin-on type, filters oil for contaminants.
3. **Spark Plug** – Provides spark to the ignition system. Set spark plug gap to 0.6 - 0.7 mm (0.028 - 0.031 inch) Clean spark plug once a week.
4. **Lifting Hook Eye** – Attach a lifting device of adequate lifting capacity at this lifting point whenever lifting of the engine is required.
5. **Fuel Filter** – Prevents dirt and other debris from entering the fuel system..
6. **Air Filter** – Prevents dirt and other debris from entering the fuel system. Unsnap air filter cover to gain access to filter element.

7. **Oil Filler Cap** – Remove to add engine oil.
8. **Oil Dip Stick** – Remove to check amount and condition of oil in crankcase. Refill or replace with recommended type oil as listed in Table 4.
9. **Starter** – Starts engine when ignition key is rotated to the "ON" position.

! WARNING - BURN HAZARD



Engine components can generate extreme heat. To prevent burns, **DO NOT** touch these areas while the engine is running or immediately after operating. **NEVER** operate the engine with the muffler removed.

NOTE

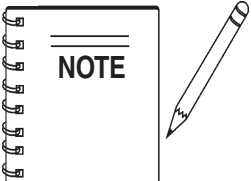

Operating the engine without an air filter, with a damaged air filter, or a filter in need of replacement will allow dirt to enter the engine, causing rapid engine wear.

AR-13HA RIDE-ON ROLLER — INSPECTION

Before Starting

1. Read safety instructions at beginning of manual.
2. Clean the **ROLLER**, removing dirt and dust, particularly the engine cooling air inlet, carburetor and air cleaner.
3. Check the air filter for dirt and dust. If air filter is dirty, replace air filter with a new one as required.
4. Check carburetor for external dirt and dust. Clean with dry compressed air.
5. Check fastening nuts and bolts for tightness.



3. Check the oil level shown on the dipstick (Figure 8).

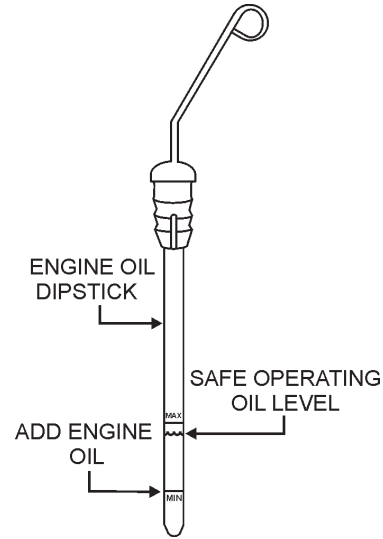

Figure 8. Engine Oil Dipstick Level

Engine Oil Check

1. To check the engine oil level, place the roller on secure level ground with the engine stopped.
2. Remove the dipstick from its holder (Figure 7) and wipe it clean.

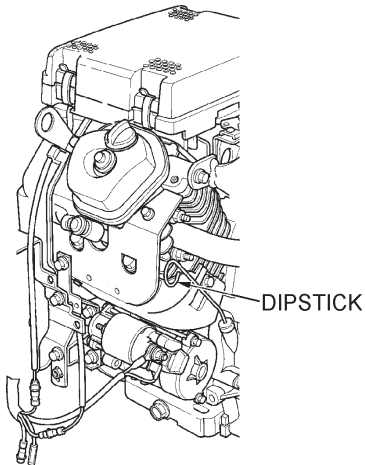

Figure 7. Engine Oil Dipstick (Removal)

4. If the oil level is low, remove the oil filler cap (Figure 9) and fill to the safe operating level (max) as indicated by the dipstick. Fill with recommended type oil as listed in Table 4. Maximum oil capacity is 1.90 quarts (1.8 liters).

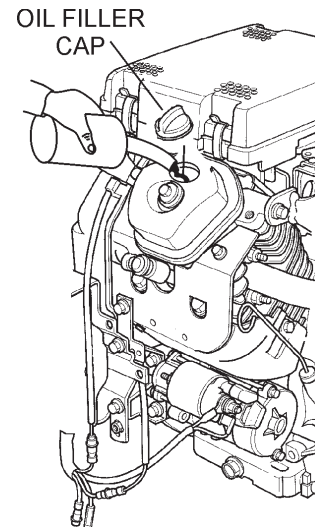
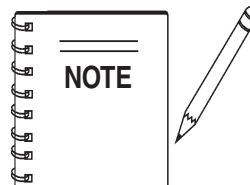

Figure 9. Engine Oil Filler Port

Table 4. Motor Oil Grade

Season or Temperature	Grade of motor oil (higher than MS class)
Spring, Summer or Autumn +120° F to +15° F	SAE 30
Winter +40° F to +15° F	SAE 30
Below +15° F	SAE 10W-30



The **HONDA GX-610** engine used on the AR-13H roller has an "**Oil Alert System**". This system will automatically stop the engine in the event of low oil level. **ALWAYS** be sure to check the engine oil level prior to starting the engine.

AR-13HA RIDE-ON ROLLER — INSPECTION

Fuel Check

! DANGER - EXPLOSIVE FUEL

NEVER fill the fuel tank while the engine is running or in the dark. Fuel spillage on a hot engine can cause a fire or explosion. If fuel spillage occurs, wipe up the spilled fuel completely to prevent fire hazards.



DO NOT smoke while refueling, motor fuels are highly flammable and can be dangerous if mishandled.

1. To check the engine fuel level, place the roller on secure level ground with the engine stopped.
2. Tilt the operator's seat (Figure 10) **forward** to gain access to the fuel tank.

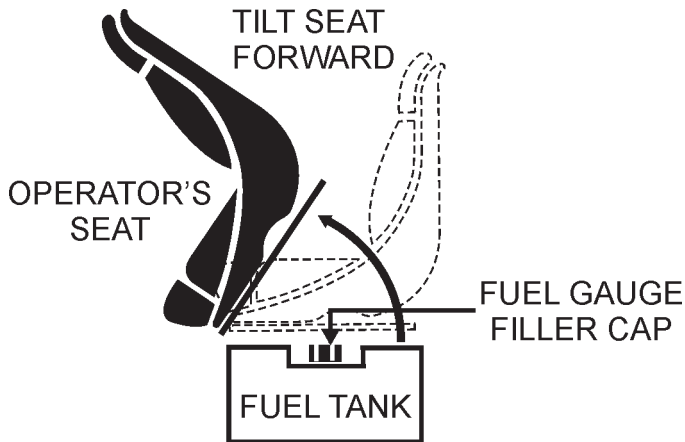

Figure 10. Fuel Tank Access

3. Read the fuel gauge (Figure 11) located on top of the fuel tank to determine if fuel level is low.



Figure 11. Fuel Gauge

4. If the fuel level is low, remove the fuel filler cap/gauge and fill with unleaded gasoline. Wipe up any spilled fuel immediately.
5. Pay attention to the fuel tank capacity when replenishing fuel (Figure 12). Refer to the fuel tank capacity listed on page 13, AR-13H Roller Specification Table 1.

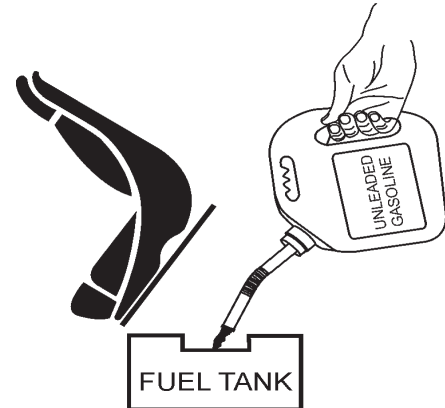

Figure 12. Adding Fuel

6. After replenishing fuel, make sure fuel cap is securely tighten to fuel tank. Return operator's seat to normal operating position.

Hydraulic Oil Check

1. To check the hydraulic oil level, place the roller on secure level ground with the engine stopped.
2. Visually inspect the hydraulic oil sight glass (Figure 13) located on the right rear of the front drum. For normal operation the hydraulic oil level must be below the top and above the bottom of the sight glass. **DO NOT OVERFILL!**

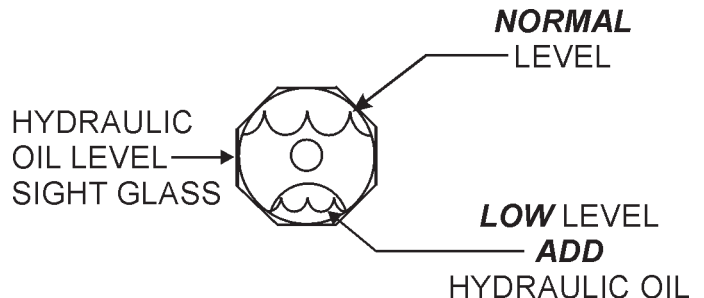

Figure 13. Hydraulic Oil Sightglass

4. If the hydraulic oil level is low, remove the hydraulic oil cap (Figure 14) and fill with type **ISO 46 anti-wear type hydraulic oil** to the recommended operating level.

AR-13HA RIDE-ON ROLLER — INSPECTION

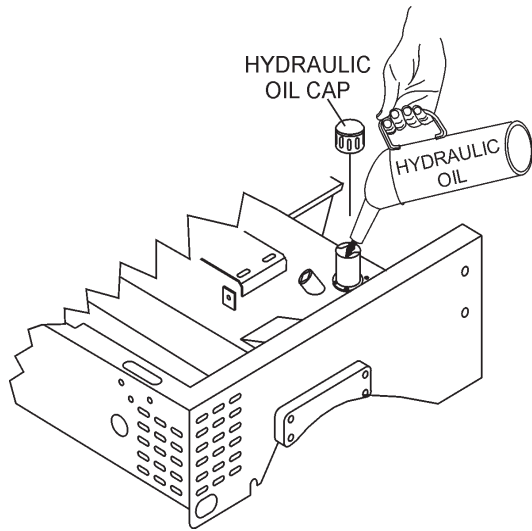

Figure 14. Hydraulic Oil Reservoir Filler Port

Battery Check

A 12-volt DC battery (Figure 16) is shipped dry, and will require a proper electrolyte level for operation.

ALWAYS be sure that the battery cables are properly connected to the battery terminals as shown below. Generally the **RED** cable will be connected to the positive terminal of the battery, and the **BLACK** cable will be connected to the negative terminal of the battery.

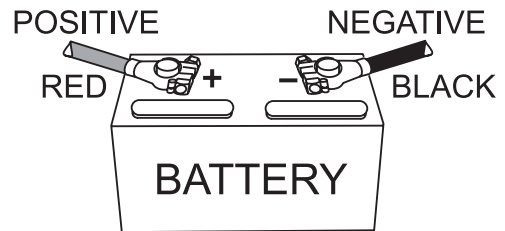

Figure 16. Battery

Water Tank Check

1. To check the water tank water level, place the roller on secure level ground.
2. The amount of water inside the water tank can be visually inspected by reading the water tube (Figure 15) that runs vertically along the water tank at the rear of the roller. This tube indicates the amount of water inside the water tank. Total tank capacity is 60 gallons (227 liters)

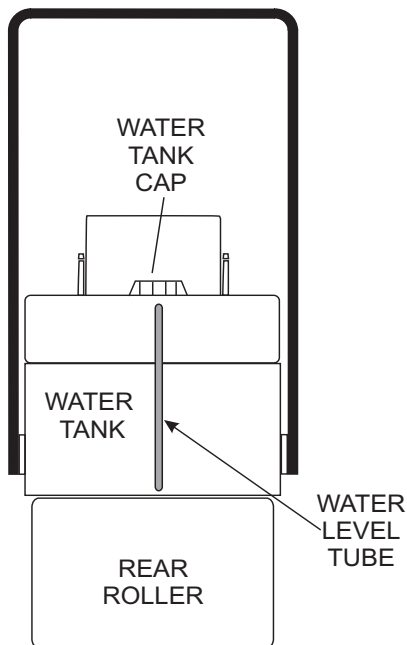

Figure 15. Water Tank

! WARNING - Battery Polarity Safety

If the battery cables are connected incorrectly, electrical damage will occur causing damage to the roller's electrical circuits. Pay close attention to the polarity of the battery when connecting the battery.

AR-13HA RIDE-ON ROLLER — INITIAL START-UP

Initial Start-up Instructions

Starting

! CAUTION - General Operation Safety

DO NOT attempt to operate the roller until the Safety, General Information and Inspection sections have been read and understood.

1. Place your foot into the roller's foot step, grab hold of the hand rail located on the steering console, and lift yourself onto the platform.
2. Sit down in the operators seat and adjust the seat for a comfortable position, then fasten the seat belt (Figure 17) around your waist. **NEVER!** operate the roller without the seat belt being fastened, serious injury could occur if the seat belt is not used.

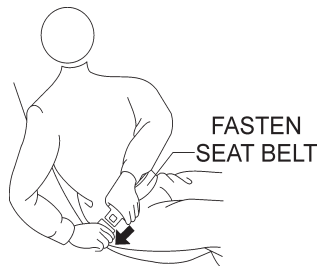

Figure 17. Securing Seat Belt

3. Before starting engine, make sure the immediate area is free of obstructions and debris that may lay in the roller's path.
4. Make sure that the roller's shift lever (Figure 18) is placed in the **neutral position**.

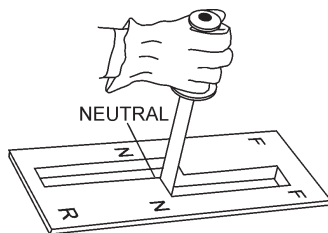

Figure 18. Shift Lever

5. In cold weather, start the roller with the choke fully **closed**. In warm weather or when the engine is warm, the roller can be started with choke halfway or completely **open**.
6. **PUSH** the "RED" button (Figure 19) on the throttle control and pull the round black knob about halfway out. Make sure that the throttle lock knob has been dis-engaged.

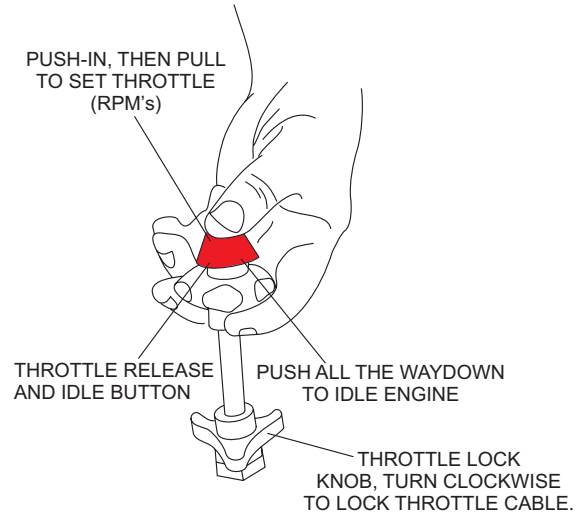

Figure 19. Throttle Control

7. Insert the ignition key into the ignition (Figure 20), then turn and hold the key in the clockwise position until the engine starts, release key.

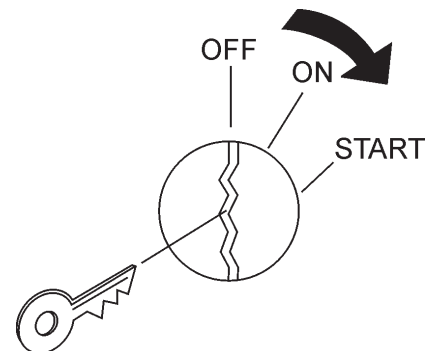
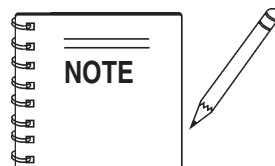

Figure 20. Ignition Switch

8. If the engine does not start, repeat steps 1 through 7 or consult the troubleshooting guide contained in this manual.
9. Let the engine warm for 3 to 5 minutes before using roller. Check for fuel and oil leaks, and noises that would associate with a loose guard and/or covers.
10. If necessary return the choke knob to the full **OPEN** position.



The **CLOSED** position of the choke knob enriches the fuel mixture for starting a **COLD** engine. The **OPEN** position provides the correct fuel mixture for normal operation after starting, and for restarting a warm engine.

AR-13HA RIDE-ON ROLLER — OPERATION

OPERATION

Parking Brake

1. To release the parking brake, press and hold the release button (Figure 21) pull up slightly on the parking lever, then push the parking brake lever all the way down.

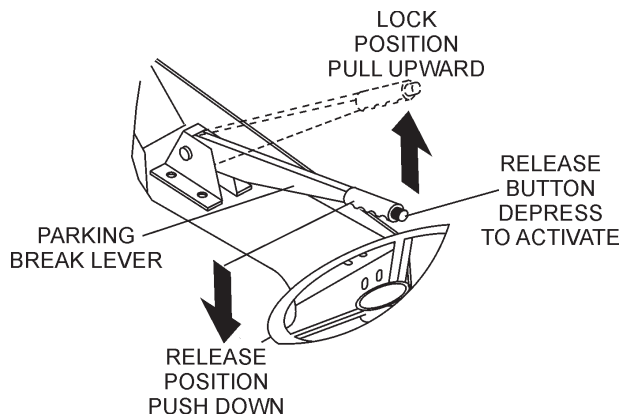

Figure 21. Brake Release Lever

Shift Lever

1. To make the roller move in a **forward direction**, move the shift lever forward as shown in Figure 22.

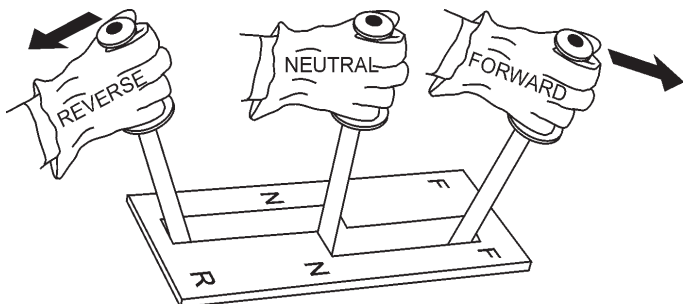

Figure 22. Shift Lever

2. Remember the speed of the roller is directly proportional to the amount of pressure being applied to the lever in each direction. Travel speed is between 0 and 4.8 mph (7.2 kph).

CAUTION - Drive System Safety

ALWAYS allow the roller to come to a complete stop before changing the direction of travel. Changing directions before the roller comes to a complete stop will result in **excessive force** being applied to the transmission and drive system, which will reduce the over service life of the system.

3. Try maneuvering the roller a few times to get familiar with the handling. Also place the travel lever in the opposite direction to get acquainted with driving in reverse.
4. Make sure that the roller comes to a complete stop (neutral) before placing the travel lever in either a forward or reverse position.

Vibration Button

1. To begin the vibratory action, **press** the vibratory pushbutton switch located on top of the travel lever as shown in Figure 23. The pressing of this switch will generate 3,100 lbs. (1,406 Kg.) of centrifugal force at a frequency of 4000 vpm (vibrations per minute) to the **front** drum.

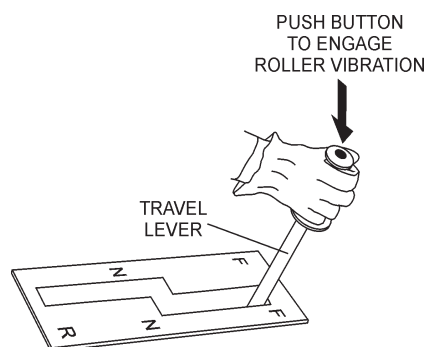

Figure 23. Vibration Pushbutton Switch

2. To stop the vibratory action, press the vibratory pushbutton switch again.

Sprinkler Controls

1. If the application requires the wetting of a surface, front and rear drum sprinkler controls have been provided. These controls (Figure 24) are located to the bottom right of the operators seat. The **front** valve controls the water supply to the front drum spray bar and the **back** valve controls water flow to the back drum spray bar.

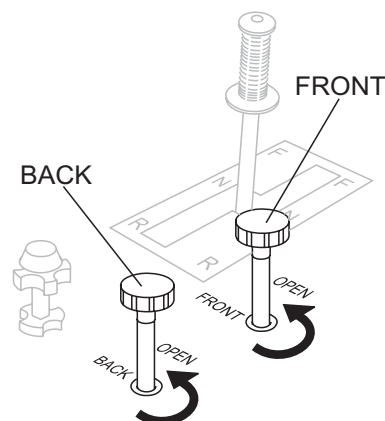

Figure 24. Sprinkler Controls

AR-13HA RIDE-ON ROLLER — MAINTENANCE

Maintenance

Perform roller maintenance as indicated by Figure 25 and Table 5.

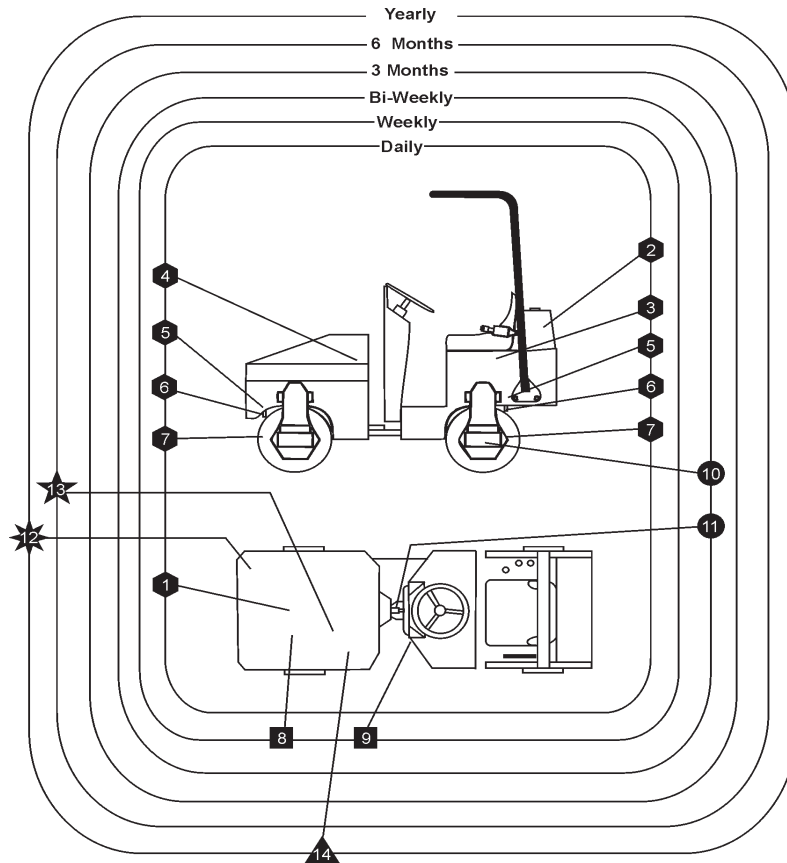

Figure 25. Roller Maintenance Schedule

Table 5. AR-13H Roller Maintenance Schedule

	Daily	1	2	3	Interval	Notes
1	Engine Oil Level	X	X			See Table 4
2	Water Tank Level	X	X			
3	Fuel Level	X	X			
4	Hydraulic Oil Level	X	X			Use ISO 46 Type Hydraulic Oil
5	Sprinkler System	X				
6	Scraper	X	X			Replace when badly worn
7	Drums (Front/Rear)	X	X			
Weekly						
8	Air Filter	X	X			Replace paper element once a year.
9	Battery Liquid Level	X	X			
Bi-Weekly						
10	Zerk Grease Fitting (Rear Drum)		X		80 hrs. or Bi-Weekly	Use Type Alvania #2 or equivalent 3 shots max. DO NOT over grease.
11	Zerk Grease Fitting (Articulation Joint)		X		80 hrs. or Bi-Weekly	Use Type Alvania #2 or equivalent 3 shots max. DO NOT over grease.
3 Months						
12	Hydraulic Oil Filter (Return)			X	500 hrs.	Replace with same type filter.
6 Months						
13	Engine Oil Filter			X	20 hrs. or 1 month	After first 20 hrs, change oil filter every 6 months or 100 hrs.
Yearly						
14	Hydraulic Oil			X	1,100 hrs. or Once a year	Use ISO 46 Type Hydraulic Oil

1 = Check 2 = Refill/ Clean / Grease 3 = Replace

AR-13HA RIDE-ON ROLLER — MAINTENANCE

Hydraulic Oil System

The hydraulic system consists of a two pump stack directly coupled to the engine. A hydraulic valve block (manifold) is provided for quick and easy testing and troubleshooting.

Hydraulic oil is filtered by a screen filter located in the tank filler neck, a **40 micron suction filter** located in the tank, and a **10 micron return filter**, with cold oil bypass valve located in the return circuit.

It is recommended that **ISO 46 type hydraulic oil** or equivalent be used when adding or replacing the hydraulic oil is required.

DO NOT USE MULTI-VISCOSITY OIL. Cleanliness is a very important part of proper hydraulic system operation. Hydraulic oil is not only used to transfer power; it also lubricates and cools the system components. Keeping the hydraulic system clean can help reduce costly repairs.

The hydraulic oil level sight glass is located on the right rear of the front drum, below the engine compartment. This level should be checked daily. Oil must be below the top and above the bottom of the sight glass. **DO NOT OVERFILL!** Care should be taken to clean the filler cap before adding oil to the system. If hydraulic oil has to be added, the machine should be inspected for leaks.

The **suction filter** (Figure 26) is located inside the hydraulic tank. This filter is attached to the fitting connected to the hydraulic pump suction hose.

The **return filter** (Figure 26) is located at the front of the engine compartment. Replace both filters according to the Table 5.

! CAUTION - HYDRAULIC SYSTEM HAZARD

DO NOT open hydraulic lines or loosen hydraulic fittings while engine is running! Hydraulic fluid under pressure can penetrate the skin, blind, cause burns or create other potentially dangerous hazards follow all safety instructions as described throughout this manual.

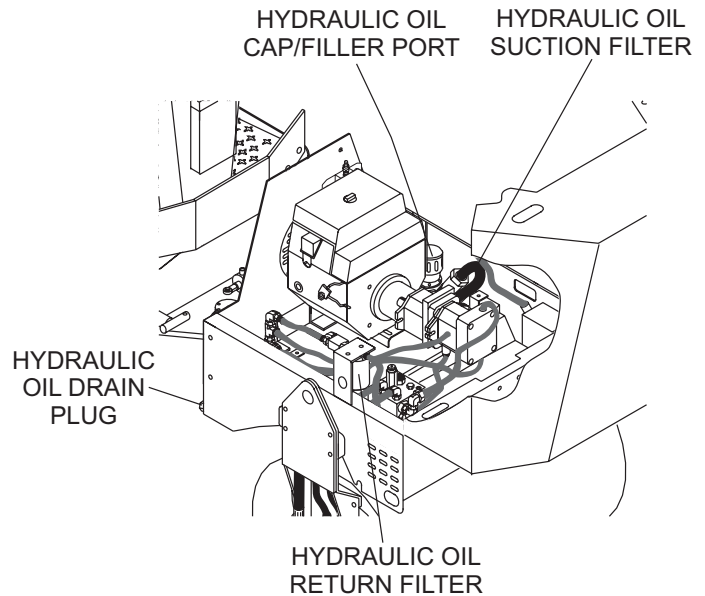

Figure 26. Hydraulic Filter Locations

Changing Hydraulic Oil and Filters

1. Park the roller on a clean flat work area and set the parking brake.
2. Remove the **hydraulic oil drain plug** (Figure 26) and drain the hydraulic oil. Dispose of the used oil in an environmentally friendly manner. Replace the drain plug and tighten.
3. Remove the return filter and **install a new filter**. Dispose of the used filter in an environmentally friendly manner.
4. Disconnect the suction hose and remove the fitting from the tank. **Replace** the suction filter. Dispose of the used filter in an environmentally friendly manner. Replace the fitting and reconnect the suction hose.

Freewheel Engagement Valve

This hydraulic system has a freewheel engagement valve allowing hydraulic oil to be bypassed. **Open** (turn allen wrench counter-clockwise) this valve (Figure 27) to engage the freewheel capability of the roller. When the valve is fully opened, ports **A** and **B** are allowed to connect, bypassing the oil to and from the drum drive motors.

Remember the freewheel engagement valve should only be used in emergencies when the roller cannot be driven due to engine or hydraulic system problems.

When towing of the roller has been completed, this valve **must** be **closed** (turn allen wrench fully clockwise) completely and the lock nut set. Failure to close this valve completely will result in low power, improper speed, and excessive hydraulic oil temperature.

AR-13HA RIDE-ON ROLLER — MAINTENANCE

CAUTION - Freewheel Engagement Valve

The freewheel engagement valve (towing) is only for **emergency use**. **DO NOT** move roller over 2 MPH or long distances as hydraulic system component failure could result.

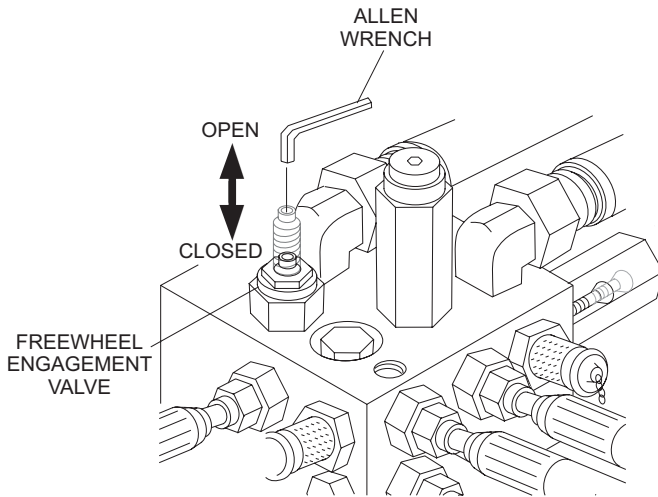

Figure 27. Freewheel Engagement Valve

Drum Drive

The drum drive circuit is a **parallel, closed loop system** (Figures 29 and 30) consisting of a hydrostatic pump, two relief valves, a freewheel engagement valve, front and rear drum drive motors.

The hydrostatic pump is manually controlled by a cable connected to the forward/reverse shift lever located on the right side of the operator seat. When the shift lever is placed in forward, high-pressure oil is supplied by the hydrostatic pump to the valve block (**port A**). The valve block (manifold) directs this high-pressure oil to the front and rear drum drive motors. Return oil from the motors is returned to the valve block (**port B**) and is returned to the suction side of the hydrostatic pump.

When shifted into reverse, the high-pressure and suction ports on the hydrostatic pump are reversed. Oil flow is then in the opposite direction of forward (**port B** becomes high-pressure and **port A** becomes suction)

Vibration and Steering

The vibration and steering system is an **open loop circuit** operated by a gear type pump. Separate relief valves control each circuit. This system consist of the gear pump, relief valves, electric vibration control valve, vibration drive motor, steering valve, and steering cylinder.

The vibration circuit is controlled by an electric control valve located on the valve block (manifold). This valve is controlled by the **“ON/OFF”** pushbutton switch mounted on top of the travel lever.

High-pressure oil is supplied by the pump to the valve block (**port P**) and is directed to the electric control valve. When the pushbutton switch is in the **“OFF”** position, this valve is **open** allowing oil to go to the steering valve, without driving the vibration motor.

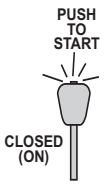

When the switch is in the **“ON”** position, the electric control valve **closes** and oil is directed out of **port 1** to the vibration motor. Return oil from the motor returns to the valve block via **port 2** and is directed to the steering valve.

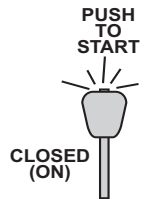

Steering is controlled by a **steering valve** and **cylinder** (Figures 29 and 30). The steering wheel is direct coupled to the steering valve controlling the oil flow to the cylinder. Oil supplied from the vibration circuit is directed to **port 3** which connects to **port P** of the steering valve. When steering is not being used, oil passes out of **port T** of the valve block and returns to the hydraulic tank. When the steering wheel is operated, the steering valve closes and oil is directed to ports **L** or **R** to extend or retract the steering cylinder.

Rubber Scrapper Mat

Rubber scrapper mats have been provided for the cleaning of the front and rear drums. Adjust the scrapper mats as close as possible to the drums, using the slotted holes (Figure 28) provided. Replace these rubber mats when they become badly worn.

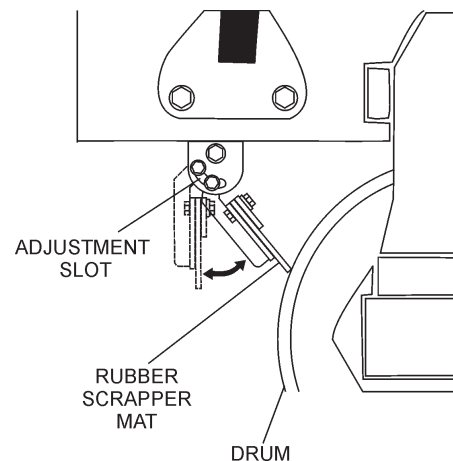

Figure 28. Scrapper Bar Adjustment

AR-13HA RIDE-ON ROLLER — MAINTENANCE

Forward/Reverse Hydraulic Pressure Test

Park the machine on a solid flat surface and stop the engine. Set the parking brake and **block the front drum securely**.

1. Check hydraulic oil level by viewing the hydraulic oil sight glass. The hydraulic oil level must be below the top and above the bottom of the sight glass. **DO NOT OVERFILL!**
2. Adjust engine RPM (3,500 +/- 50 RPM)
3. Let engine run for 5 minutes, this will bring the hydraulic oil operating temperature to a minimum of 135° fahrenheit.
4. Check and repair all hydraulic leaks.
5. On the manifold block install a 5,000 psi pressure gauge (Figure 34) to the **forward** pressure quick disconnect test port 2
6. Run engine at full throttle.
7. Move the **travel lever** to the forward position. **MAKE SURE FRONT AND REAR DRUMS DO NOT SPIN.**
8. Read the pressure gauge. The **relief pressure** (roller drums blocked) will read 2,900 ± 145 psi. Under **normal operating** conditions this pressure will read 400-600 psi.
9. Return the travel lever to the **neutral** position and **stop** the engine.
10. Install the pressure gauge into the reverse quick disconnect **port 3** and repeat the above procedures. The relief pressure reading for the **reverse** test port 3 will be the same (2,900 psi). Again normal operation pressure for the reverse port will be 400-600 psi.

Vibration Circuit Pressure Test

Place the front drum on soil, gravel, or a heavy rubber mat. **DO NOT ACTIVATE VIBRATION FEATURE ON CONCRETE OR HARD SURFACE!**

1. On the manifold block install a 5,000 psi pressure gauge to quick disconnect test port 1.
2. Start the engine and run at full throttle.
3. To start the vibration, **press** the pushbutton switch (vibration control) located on top of the travel lever. Under normal operating conditions this pressure will range between 800-1,000 psi.

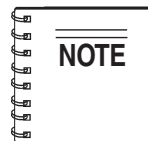

Vibration relief pressure is hard to read accurately using this test. It may be necessary to disconnect the pressure line to the vibration drive motor. Plug this line and re-test, pressure will be exact relief pressure. **DO NOT** perform this test for a long period of time — damage could occur.

Steering Pressure Test

1. On the manifold block, install a 5,000 psi pressure gauge into quick disconnect test **port 1** (Figure 34).
2. Start the engine and run at full throttle.
3. Turn the steering wheel to the **left or right** (maximum) and hold. Read the steering relief pressure. The **relief pressure** reading for the **steering** test port 1 will be 700 psi. Again, under normal operating conditions, pressure for the steering port will be between 200-400 psi.

If maximum pressure cannot be reached, plug the steering cylinder pressure hoses and re-test. If pressure is correct the steering cylinder is leaking. **DO NOT ACTIVATE THE VIBRATION FUNCTION WHILE PERFORMING THIS TEST !**

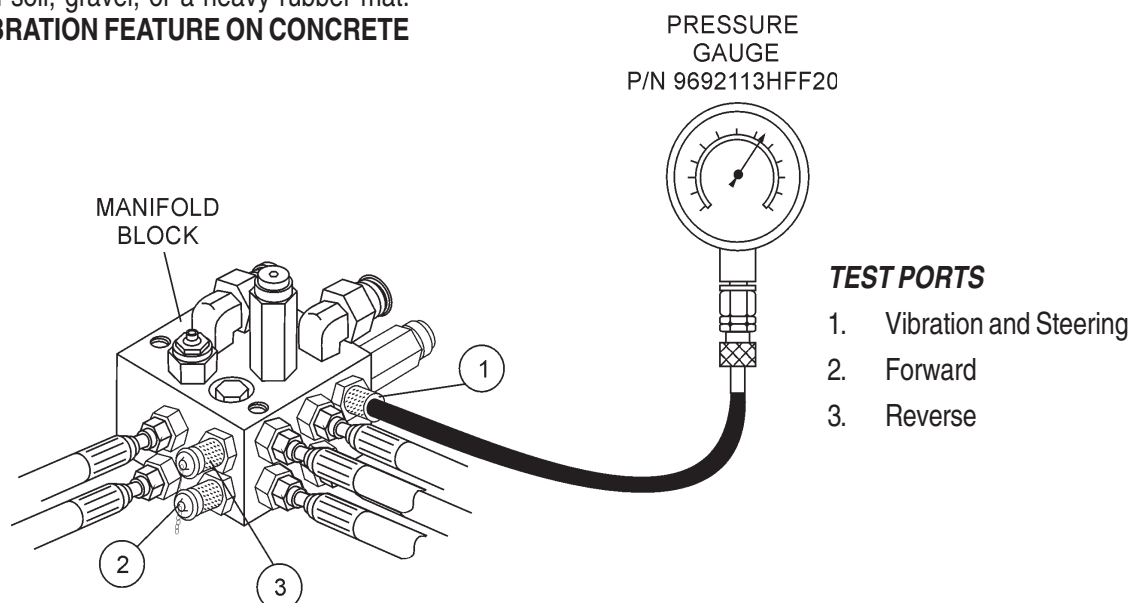
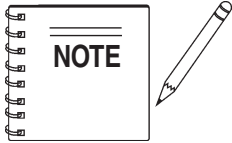

Figure 34. Manifold Test Ports

AR-13HA RIDE-ON ROLLER — MAINTENANCE

Forward/Reverse Relief Valves Drive Adjustment

The **forward** and **reverse** relief valves (Figure 35) are shim type cartridge type and are located in the hydrostatic pump (not on the manifold block) under plugs 1 and 2. Plug 2 is located in the same location as plug 1, except it is on the bottom side of the pump. Relief valve 1 is **reverse** and 2 is **forward**.



Axle Pumps supplied **after 01/01/2003** **DO NOT** have adjustable relief cartridges. The pressure is fixed at 2,900 ± 145 psi. If the relief pressure is not within normal range, the complete cartridge must be replaced.

1. Clean the area around the cap.
2. Remove the cap.
3. Carefully remove the valve cartridge.
4. Using an **allen wrench**, remove the top nut (extreme care must be taken not to loosen existing shims, spring, or valve) Add or remove shims as required. **Adding** shims increases pressure; **removing** shims lowers pressure. One shim is equal to approximately 50 psi. Shim P/N is 34538.
5. Install the top nut and install valve in the pump cavity using extreme care not to bind.
6. Install the valve cap.
7. Re-test pressure, further adjustment may be needed if pressure is not correct.

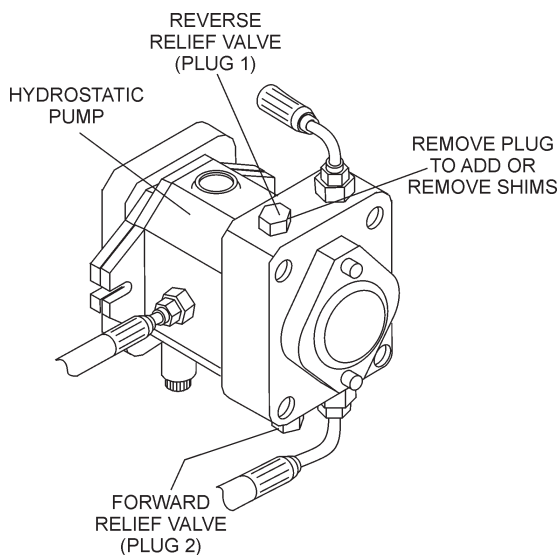

Figure 35. Adjusting Forward/Reverse Relief Valves

Steering Relief Valve Pressure Adjustment

To adjust the relief valve steering pressure perform the following:

1. Insert an 8 mm allen wrench into steering relief **port 4** (Figure 36) on the manifold block.
2. On the manifold, connect at 5,000 psi pressure gauge into quick disconnect test **port 1**.
3. Start the engine and run at full throttle.
4. Turn the steering wheel to the **left or right** (maximum) and hold. Read the steering relief pressure. The **relief pressure** reading for the **steering** test port 1 will should be 700 psi.
5. If the steering relief pressure is not 700 psi, using the allen wrench adjust the pressure at **port 4** until the pressure gauge reads 500 psi.

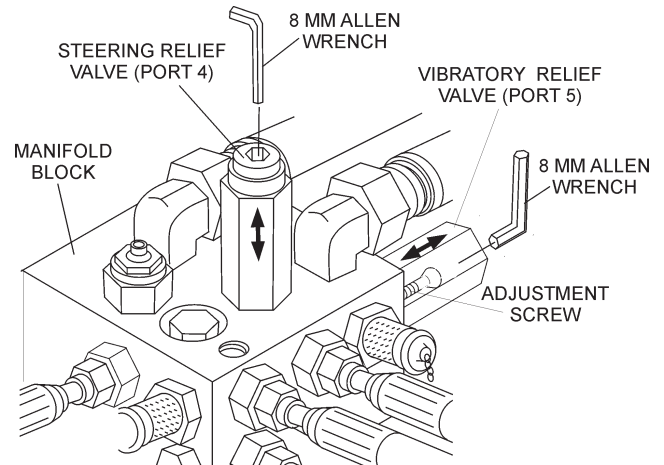

Figure 36. Steering and Vibration Relief Valves

Vibration Relief Valve Pressure Adjustment

1. Insert an 8 mm allen wrench into steering relief **port 5** (Figure 36) on the manifold block.
2. On the manifold block, insert a 5,000 psi pressure gauge into quick disconnect test **port 1**.
3. Start the engine and run at full throttle.
4. To start the vibration, **press** the pushbutton switch (vibration control) located on top of the travel lever. The relief pressure should read 800 ~ 1,000 psi.
5. If the vibration relief pressure is not 800 ~ 1,000 psi using the allen wrench adjust the pressure at **port 5** until the pressure gauge reads correctly.

Removing and Replacing Hydrostatic Pump

1. Set the parking brake.
2. Disconnect the battery.
3. Clean the pump and all connections.
4. Mark and disconnect all hoses and lines from the pump.
5. Disconnect the forward / reverse control cable.
6. Disconnect the pump support bracket.
7. Remove the engine mounting bolts.
8. Elevate the pump and engine assembly using a proper lifting device.
9. Disconnect and remove the hydrostatic pump assembly.
10. Repair or replace the hydrostatic pump as required.
11. Install the hydrostatic pump in the reverse order of removal, using *Loctite 271* on all mounting bolts and nuts.
12. Test operate. Test and adjust the forward and reverse relief pressures as required. Adjust the forward / reverse control cable.

Removing and Replacing Vibration/Steering Pump

1. Remove the hydrostatic pump as per preceding instructions.
2. Remove all hoses and lines.
3. Disconnect the vibration / steering pump and remove.
4. Repair or replace pump as required.
5. Install the pump in the reverse order of removal, using *Loctite 271* on all mounting bolts and nuts.
6. Test operate. Test and adjust the forward and reverse pressure relief valves as required. Adjust the **forward/reverse control cable**. Test and adjust the vibration and steering pressure relief valves as required.

Drums and Main Frame

The front drum is designed to apply vibration and compaction force to the operating surface for compaction. This vibration and compaction force is produced when the vibrator shaft is rotated. Maximum efficiency is achieved only when the engine is operated at full throttle.

A single drive motor is mounted on the left side of the drum and is shockmounted. This type of drive motor is designed for maximum torque and power.

The vibrator is driven by a gear motor coupled to the vibrator shaft. The vibrator assembly rotates inside of a sealed housing containing oil to lubricate the bearings. This side of the drum is also shock mounted.

Front and Rear Drum Removal and Disassembly.

The removal and disassembly of the front and rear drums shall be referenced by Figures 37, 38, and 39 on the following pages. When reassembling the front drum use *Loctite 271* on all mounting hardware.

AR-13HA RIDE-ON ROLLER — MAINTENANCE

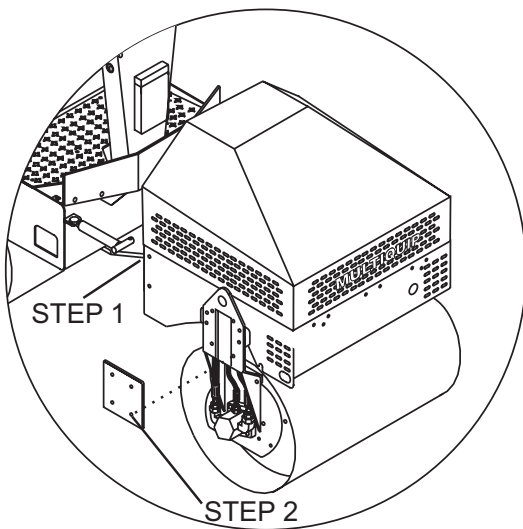

1. JACK FRAME UP SLIGHTLY AT ARTICULATION JOINT.
2. REMOVE THE FOUR ALLEN HEAD SCREWS HOLDING THE SIDE COVER OF THE DRUM SUPPORT PLATE.

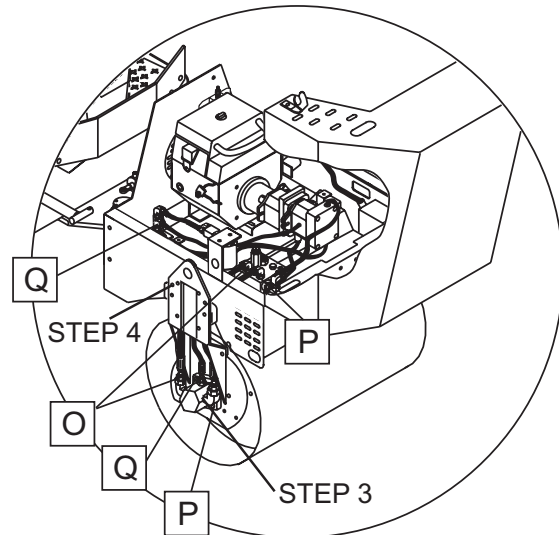

3. MARK AND DISCONNECT HOSES FROM MOTOR AND MANIFOLD.
4. REMOVE FOUR ALLEN HEAD SCREWS FROM DRUM SUPPORT PLATES.(SCREWS MAY NEED TO BE HEATED TO REMOVE)

5. REMOVE NUTS SECURING FLANGE ASSEMBLY TO DRUM SUPPORT PLATE AND PULL OFF OF FLANGE ASSEMBLY.
6. REMOVE THE SIX 9/16 BOLTS SECURING EXCITER PLATE TO DRUM WALL

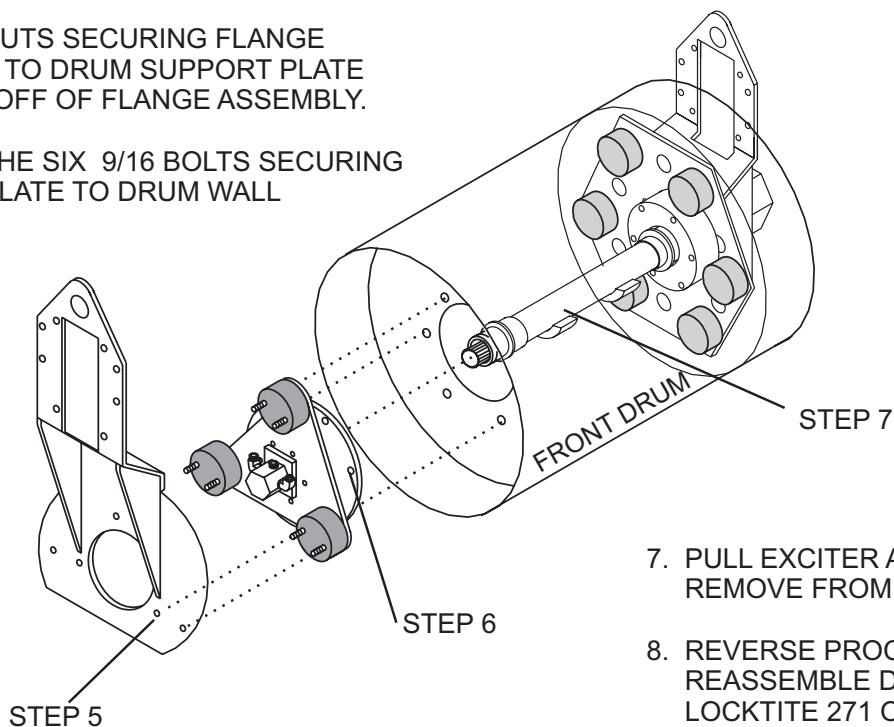

7. PULL EXCITER ASSEMBLY TO REMOVE FROM DRUM INTERIOR.
8. REVERSE PROCEDURES TO REASSEMBLE DRUM. USE LOCKTITE 271 ON ALL BOLTS AND NUTS.

Figure 37. Front-Right Drum Removal

AR-13HA RIDE-ON ROLLER — MAINTENANCE

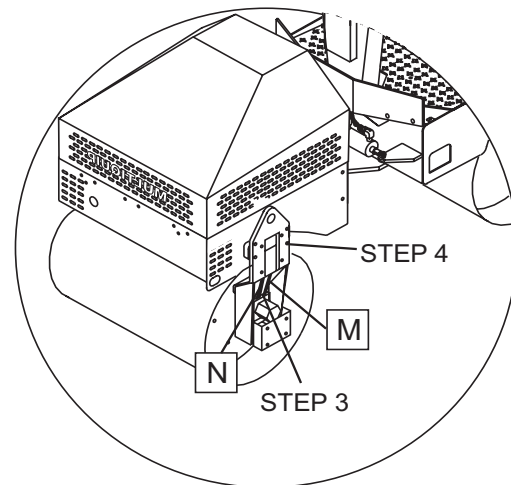
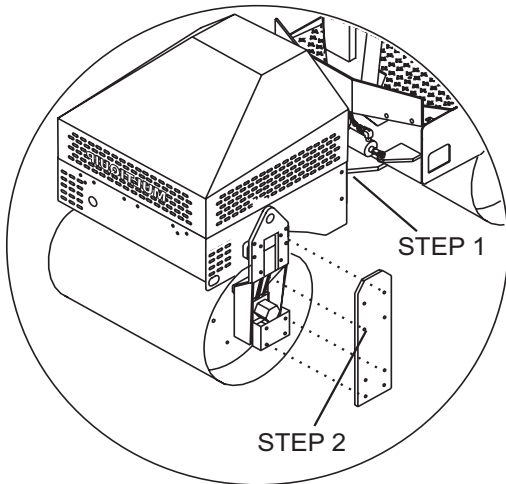

1. JACK FRAME UP SLIGHTLY AT ARTICULATION JOINT.

2. REMOVE THE EIGHT ALLEN HEAD SCREWS HOLDING THE SIDE COVER OF THE DRUM SUPPORT PLATE.

3. MARK AND DISCONNECT HOSES FROM MOTOR.

4. REMOVE FOUR ALLEN HEAD SCREWS FROM DRUM SUPPORT PLATE. (SCREWS MAY NEED TO BE HEATED TO REMOVE)

5. PULL DRUM SUPPORT PLATE OFF DRIVE PLATE ASSEMBLY.

6. REMOVE FOUR ALLEN HEAD SCREWS SECURING MOTOR TO DRUM SUPPORT PLATE AND SET ASIDE.

7. REMOVE SIX NUTS SECURING DRIVE PLATE TO SHOCK MOUNTS. PULL OFF DRIVE PLATE AND SET ASIDE.

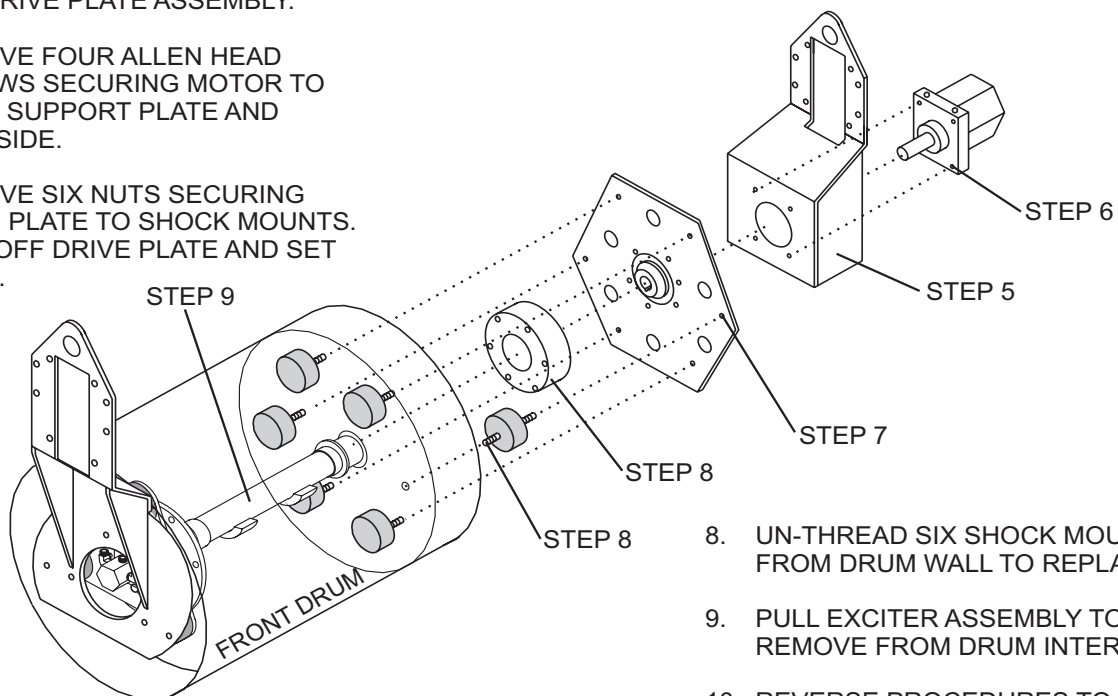

8. UN-THREAD SIX SHOCK MOUNTS FROM DRUM WALL TO REPLACE.

9. PULL EXCITER ASSEMBLY TO REMOVE FROM DRUM INTERIOR.

10. REVERSE PROCEDURES TO REASSEMBLE DRUM. USE LOCKTITE ON ALL NUTS AND BOLTS.

Figure 38. Front-Left Drum Removal

AR-13HA RIDE-ON ROLLER — MAINTENANCE

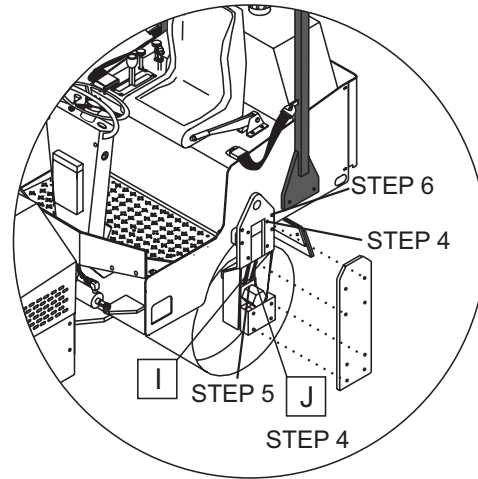
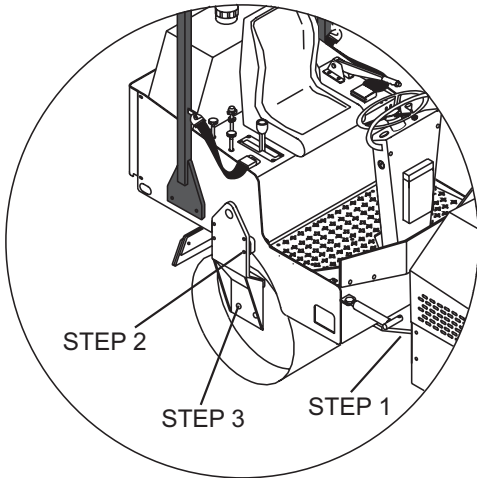

1. JACK FRAME UP SLIGHTLY AT ARTICULATION JOINT.
2. REMOVE THE FOUR ALLEN HEAD SCREWS SECURING THE DRUM SUPPORT PLATE TO THE FRAME.
3. REMOVE NUTS SECURING BEARING FLANGE TO BASE OF DRUM SUPPORT PLATE.
7. REMOVE TWO NUTS SECURING DRUM SUPPORT PLATE TO FLANGE. PULL OFF LEFT DRUM SUPPORT PLATE AND SET ASIDE.
8. PULL FLANGE OFF DRUM ROD FOR SERVICE.
9. PULL RIGHT DRUM SUPPORT PLATE OFF DRIVE PLATE ASSEMBLY.

4. REMOVE ALLEN HEAD SCREWS HOLDING THE SIDE COVER OF THE DRUM SUPPORT PLATE.
5. MARK AND DISCONNECT HOSES FROM MOTOR.
6. REMOVE FOUR ALLEN HEAD SCREWS FROM DRUM SUPPORT PLATES.

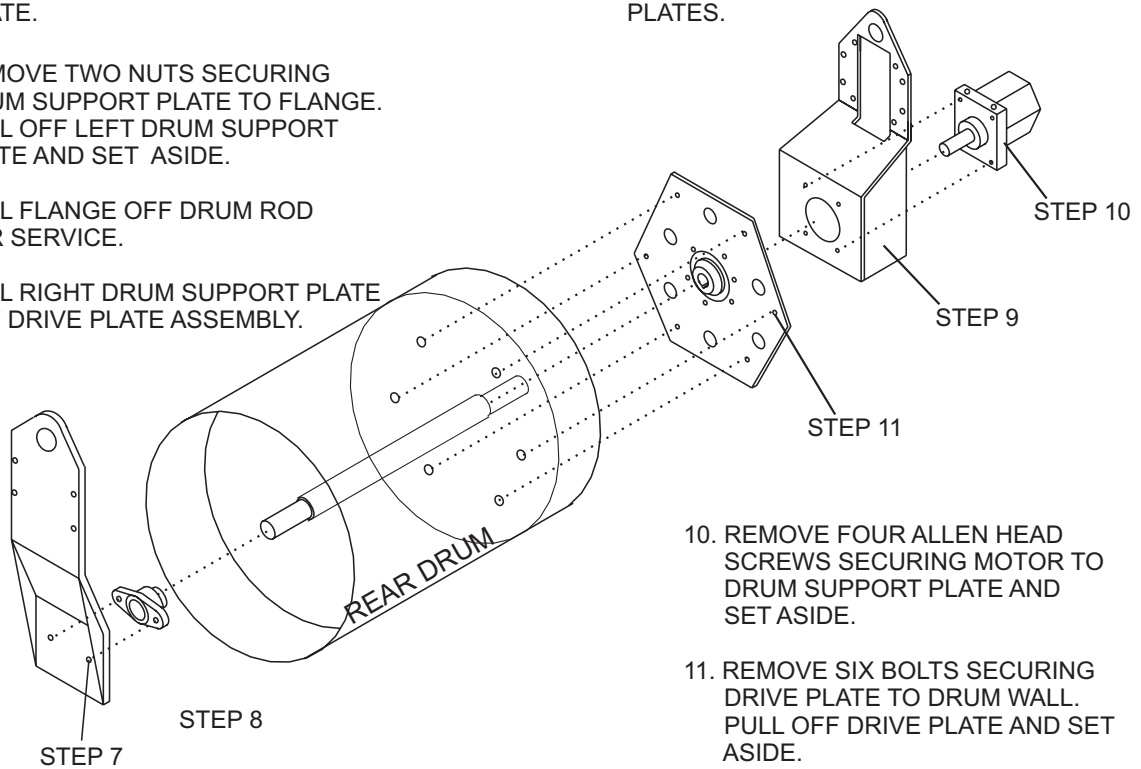

10. REMOVE FOUR ALLEN HEAD SCREWS SECURING MOTOR TO DRUM SUPPORT PLATE AND SET ASIDE.
11. REMOVE SIX BOLTS SECURING DRIVE PLATE TO DRUM WALL. PULL OFF DRIVE PLATE AND SET ASIDE.
12. REVERSE PROCEDURES TO REASSEMBLE DRUM.

Figure 39. Rear Drum Removal/Installation

AR-13HA RIDE-ON ROLLER — MAINTENANCE

Alternator/Regulator

The AR-13H is equipped with a 20 amp charging system. This system uses three charge coils connected in parallel. The windings of each coil are wound with heavy-duty insulated wire and are further protected by insulating material for long life. A voltage regulator is provided to control the amount of charge voltage being delivered to the 12 volt electrical system. For servicing this charging system, contact your Honda dealer.

Neutral Safety Switch

The **travel lever** is provided with a **neutral safety switch** (Figure 40) that prevents the engine from starting when the lever is in the forward or reverse drive position. Lever must be placed in the neutral position in order for the starter to function.

To check this switch, remove the panel located below and to the rear of the floor. This switch is mounted to the lower forward/reverse lever mechanism. Disconnect the **white** and **green** wires. Place the lever in neutral and test for continuity. Place the lever in forward or reverse; no continuity should be present. Repair or replace as required.

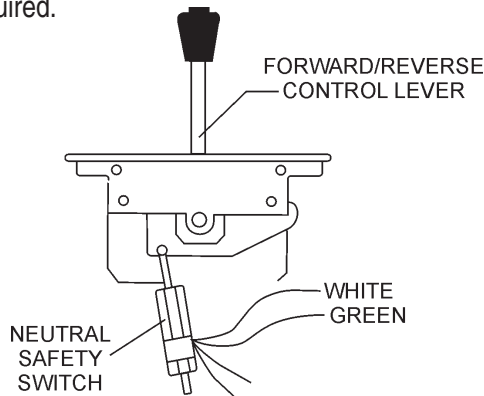

Figure 40. Safety Switch

Vibrator Solenoid

The vibrator solenoid (Figure 41) is located in the manifold valve block and is controlled by the vibration switch located on top of the travel lever. This solenoid controls the vibration control valve which supplies hydraulic oil to the vibration drive motor.

To test the vibration solenoid, turn the ignition switch on. Check for proper supply voltage and ground. If proper voltage and ground are present, check the solenoid for continuity. If no continuity, replace the solenoid coil. If continuity is present, place your hand on the solenoid and turn the switch to the **ON** position; movement should be felt. **DO NOT START THE ENGINE FOR THIS TEST**

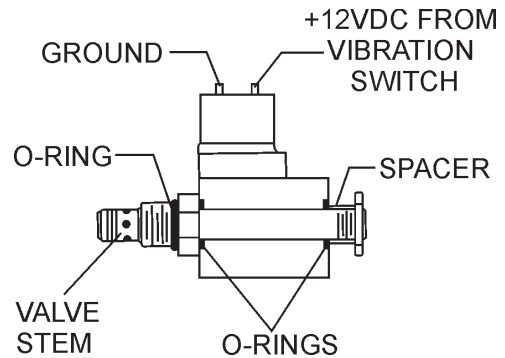

Figure 41. Vibration Solenoid

Battery

Mishandling of the battery shortens the service life of the battery and adds to maintenance cost. When handling the battery do the following:

- Be careful not to let the battery electrolyte come in contact with your body or clothing.
- Always wear eye protection and rubber gloves, since the battery contains sulfuric acid which burns skin and eats through clothing.

! CAUTION - BATTERY ACID BURN HAZARD

If your clothing or skin comes in contact with the battery acid, **immediately** wash off with running water and get medical attention.

- Check the battery regularly and make sure that each electrolyte level is to the bottom of the vent well (Figure 42). If necessary add only distilled water in a well-ventilated area.

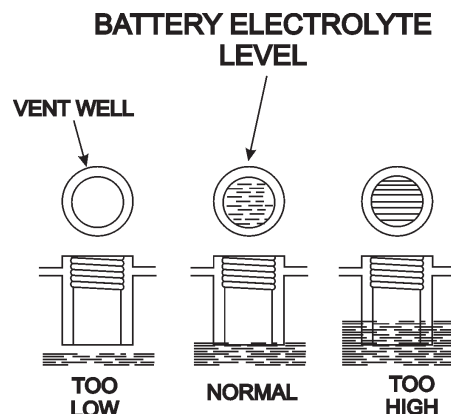

Figure 42. Battery Fluid Levels

AR-13HA RIDE-ON ROLLER — PREPARATION FOR LONG-TERM

Roller Storage

For storage of the roller for over 30 days, the following is recommended:

- Drain the fuel tank completely, or add STA-BIL to the fuel.
- Run the engine until the fuel in the injection system is completely consumed.
- Completely drain used oil from the engine crankcase and fill with fresh clean oil, then follow the procedures described in the engine manual for engine storage.
- Drain water tank
- Clean the entire roller and engine compartment.
- Remove battery and store it in cool dry place.
- Cover the roller and place it a clean dry area, that is protected from harsh elements.
- Remove ignition key, and store in a safe place.

AR-13HA RIDE-ON ROLLER — MANIFOLD TEST PORTS

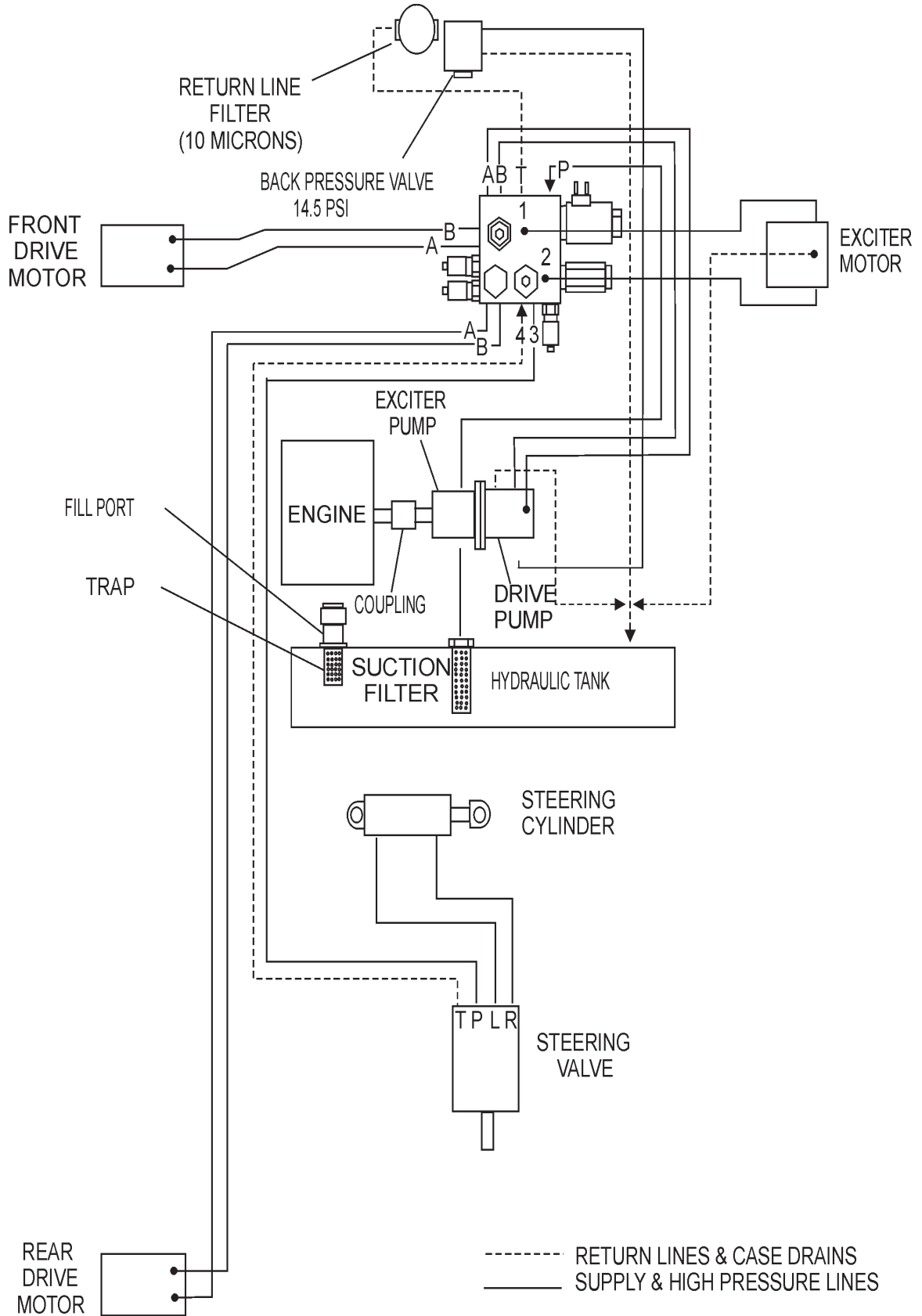

Figure 29. Manifold Test Ports

AR-13HA RIDE-ON ROLLER — HYDRAULIC SYSTEM DIAGRAM

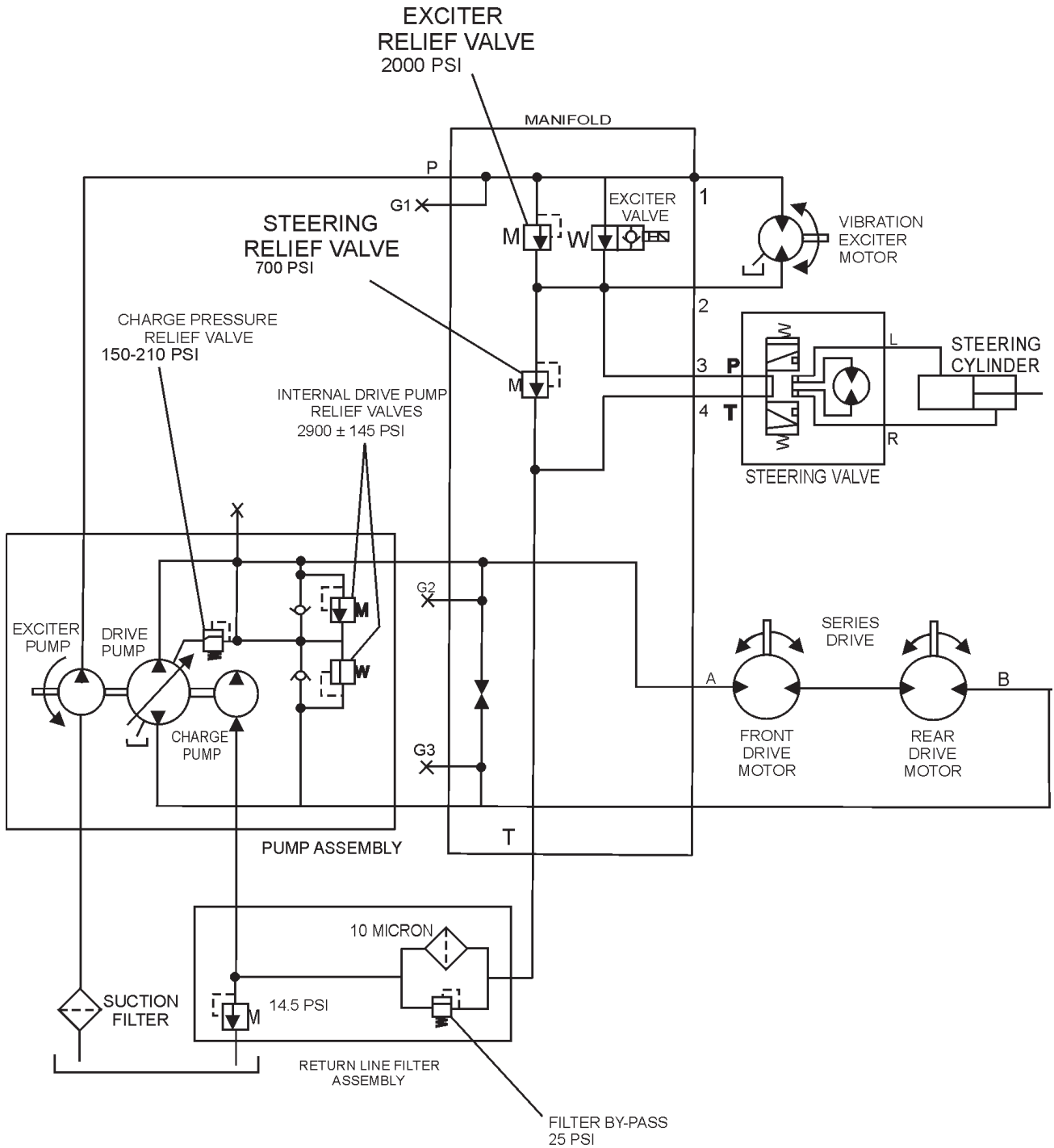
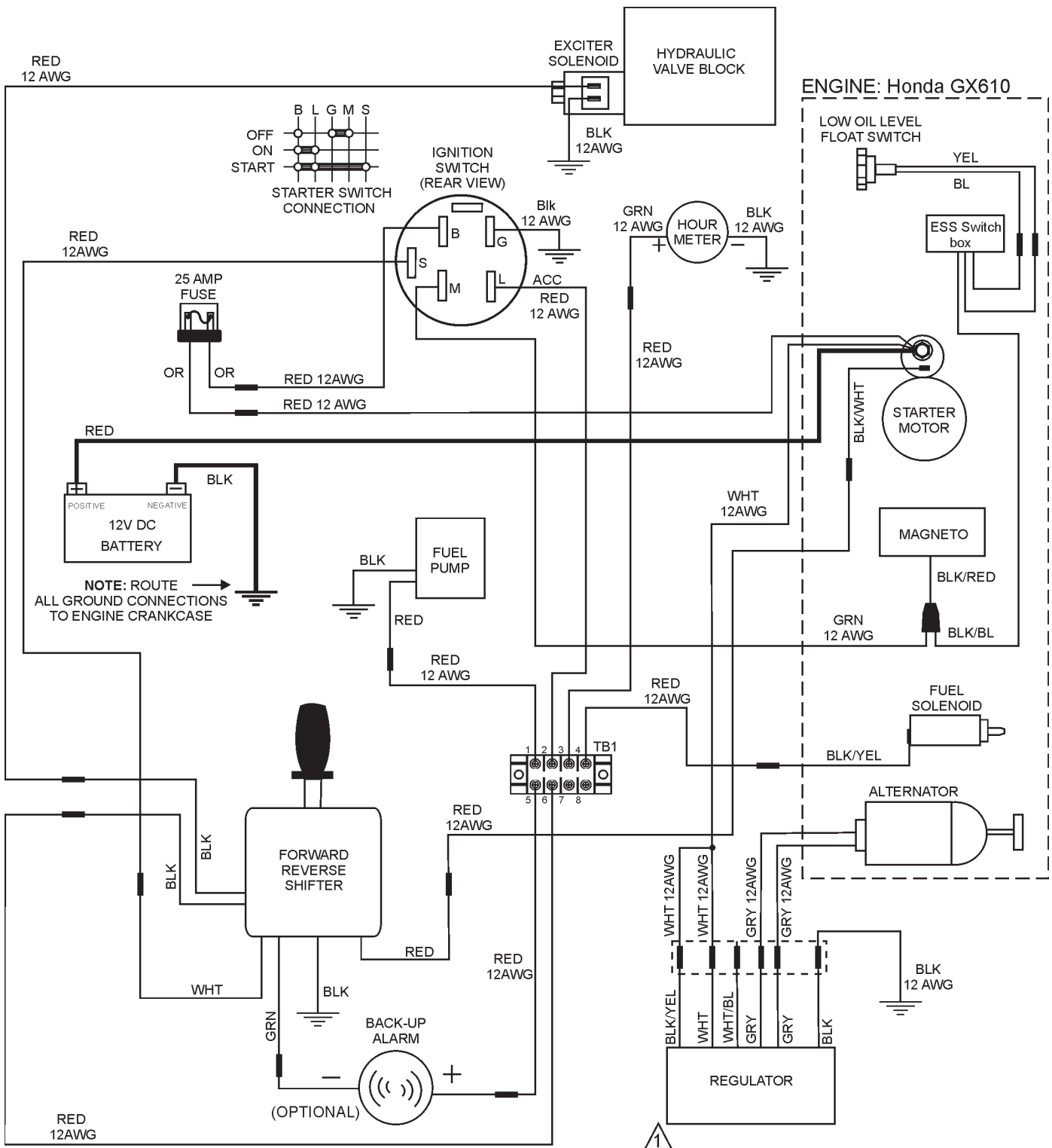

Figure 30. Hydraulic System Diagram

AR-13H ROLLER — ELECTRIC WIRING DIAGRAM



NOTE:

⚠ WHITE WIRE WITH BLUE STRIPE ON REGULATOR IS NOT USED.

BL = BLUE
 GRY = GRAY
 GRN = GREEN
 OR = ORANGE
 BLK = BLACK
 YEL = YELLOW
 WHT = WHITE

AR-13HA RIDE-ON ROLLER — HYDRAULIC HOSE CONNECTIONS

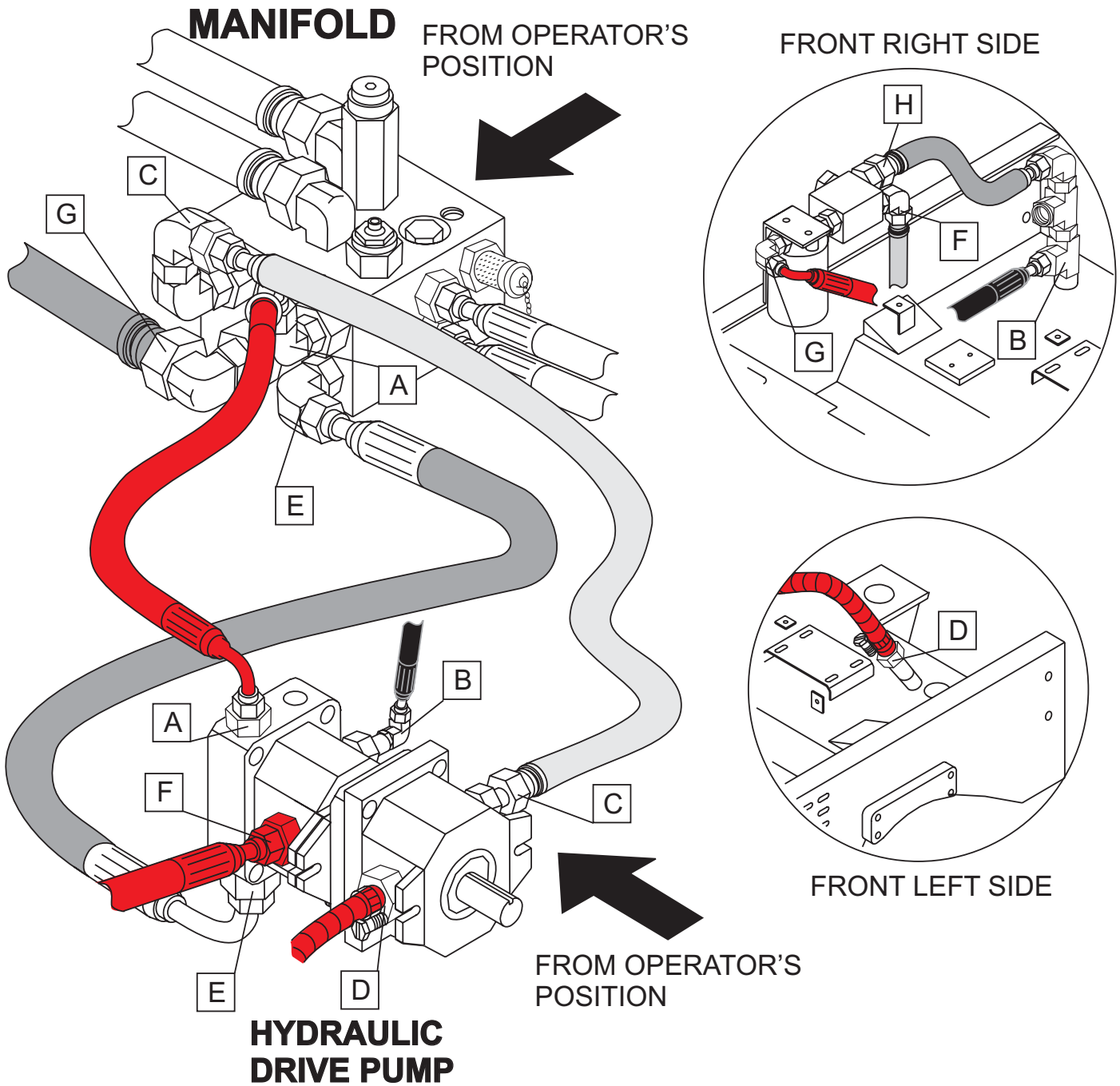

NOTES

HOSES SHADED FOR VISUAL CLARITY.

Figure 32. Hydraulic Hose Connections 1

AR-13HA RIDE-ON ROLLER — HYDRAULIC HOSE CONNECTIONS

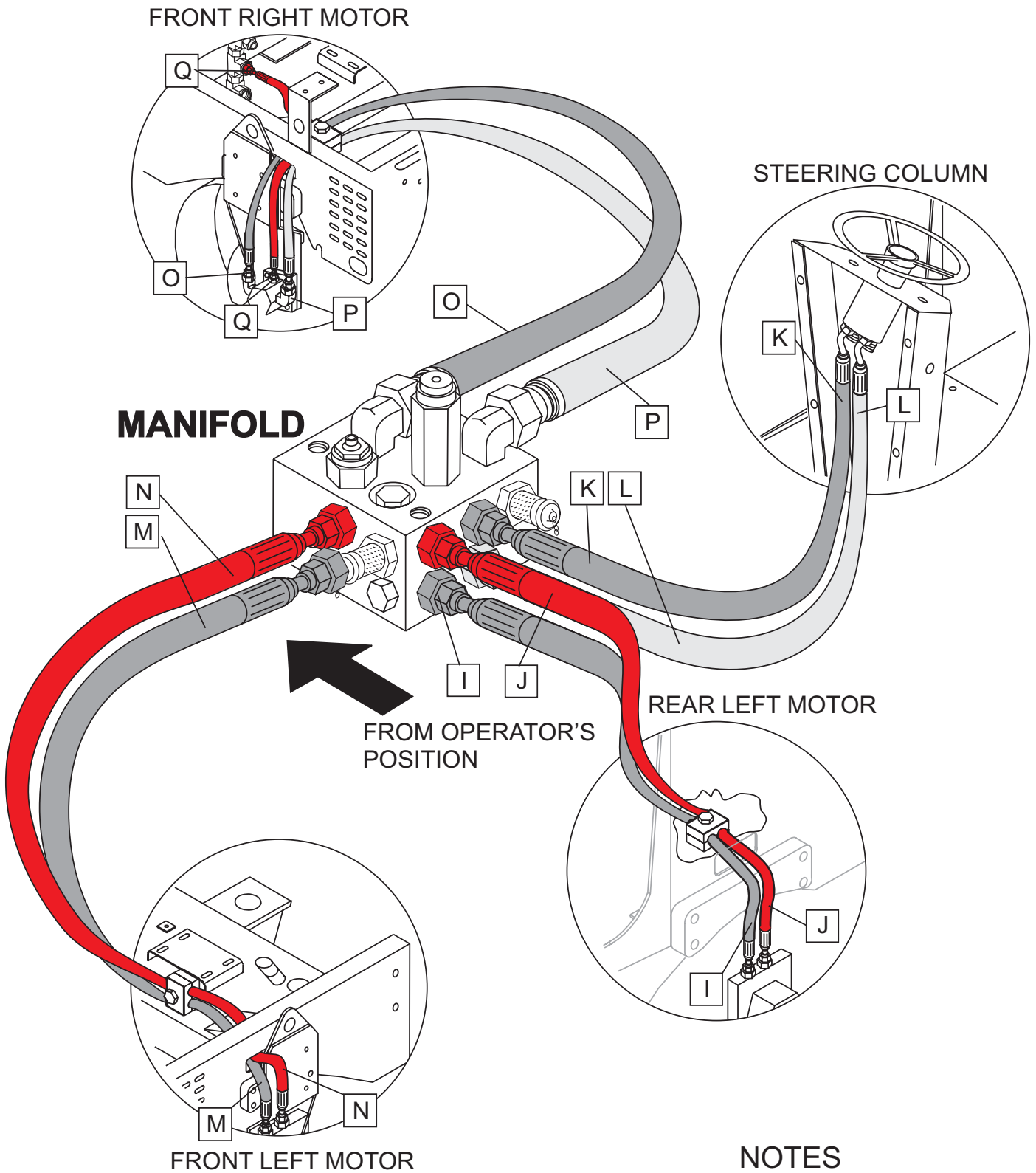

NOTES

HOSES SHADED FOR VISUAL CLARITY.

Figure 33. Hydraulic Hose Connections 2

AR-13HA RIDE-ON ROLLER — TROUBLESHOOTING (ROLLER)

TABLE 6. ROLLER TROUBLESHOOTING

SYMPTOM	POSSIBLE PROBLEM	SOLUTION
Low Vibration	Low engine RPM?	Check and adjust engine speed.
	Low hydraulic pressure?	Check and adjust hydraulic pressure.
No Vibration	No voltage to 12 volt solenoid?	Check vibration switch, check coil for continuity.
	No oil pressure?	Check for proper oil pressure or defective relief valve.
	Broken motor coupler?	Replace coupler.
Slow Steering	Low hydraulic pressure?	Check pressure.
	Steering column connector?	Inspect bearings and grease if necessary.
	Defective steering cylinder?	Check seals, replace if necessary.
Steers Slow in One Direction	Defective Steering cylinder?	Inspect cylinder for contamination, replace if necessary.
Slow Forward/Reverse Speed	Low hydraulic pressure?	Check pressure.
	Rubber scrapper adjustment incorrect?	Check for proper adjustment against drum.
	Rubber shock mount loose?	Inspect for broken mount, replace if necessary.
	Free wheel valve " <i>open</i> "?	Close valve.
	Speed control cable out of adjustment?	Inspect cable and adjust if necessary.
Main Hydraulic Pressure Low	Incorrect engine speed?	Adjust engine speed to correct speed.
	Broken rubber shock mounts or drive plate?	Inspect for cracks, replace if necessary.
	Drive motor hardware not secure?	Check motor nut and key coupler.

AR-13HA RIDE-ON ROLLER — TROUBLESHOOTING (ENGINE)

TABLE 7. ENGINE TROUBLESHOOTING

SYMPTON	POSSIBLE PROBLEM	SOLUTION
Engine will not start or start is delayed, although engine can be turned over.	No Fuel reaching injection pump?	Add fuel. Check entire fuel system.
	Defective fuel pump?	Replace fuel pump.
	Fuel filter clogged?	Replace fuel filter and clean tank.
	Faulty fuel supply line?	Replace or repair fuel line.
	Compression too low?	Check piston, cylinder and valves. Adjust or repair per engine repair manual.
	Fuel pump not working correctly?	Repair or replace fuel pump.
	Oil pressure too low?	Check engine oil pressure.
	Low starting temperature limit exceeded	Comply with cold starting instructions and proper oil viscosity.
	Defective battery?	Charge or replace battery.
At low temperatures engine will not start.	Engine oil too thick?	Refill engine crankcase with correct type of oil for winter environment.
	Defective battery?	Replace battery.
Engine fires but stops soon as starter is switched off.	Fuel filter blocked?	Replace fuel filter.
	Fuel supply blocked?	Check the entire fuel system.
	Defective fuel pump?	Replace fuel pump.
Engine stops by itself during normal operation.	Fuel tank empty?	Add fuel.
	Fuel filter blocked?	Replace fuel filter.
	Defective fuel pump?	Replace fuel pump.
	Mechanical oil pressure shutdown sensor stops the engine due to low oil?	Add oil. Replace low oil shutdown sensor if necessary.

AR-13HA RIDE-ON ROLLER — TROUBLESHOOTING (ENGINE)

TABLE 7. ENGINE TROUBLESHOOTING (CONTINUED)

SYMPTON	POSSIBLE PROBLEM	SOLUTION
Low engine power, output and speed.	Fuel tank empty?	Replace fuel filter.
	Fuel filter clogged?	Replace fuel filter.
	Fuel tank venting is inadequate?	Ensure that tank is adequately vented.
	Leaks at pipe unions?	Check threaded pipe unions tape and tighten unions as required.
	Speed control lever does not remain in selected position?	See engine manual for corrective action.
	Engine oil level too full?	Correct engine oil level?
Low engine power output and low speed, black exhaust smoke.	Air filter blocked?	Clean or replace air filter.
	Incorrect valve clearances?	Adjust valves per engine specification.
	Malfunction at injector?	See engine manual.
Air-cooled diesel engine runs very "HOT". Cylinder head overheats.	Too much oil in engine crankcase?	Drain off engine oil down to uppermark on dipstick.
	Entire cooling air system contaminated blocked?	Clean cooling air system, and cooling fin areas.

AR-13HA RIDE-ON ROLLER — EXPLANATION OF PARTS SECTION

The following section explains the different symbols and remarks used in the Parts section of this manual. Use the help numbers found on the back page of the manual if there are any questions.

The contents and part numbers listed in the parts section are subject to change **without notice**. Multiquip does not guarantee the availability of the parts listed.

Sample Parts List:

NO.	PART NO.	PART NAME	QTY.	REMARKS
1	12345	BOLT	1	INCLUDES ITEMS W/*
2*		WASHER, 1/4 IN.		NOT SOLD SEPARATELY
2*	12347	WASHER, 3/8 IN.	1	MQ-45T ONLY
3	12348	HOSE	A/R ..	MAKE LOCALLY
4	12349	BEARING	1	S/N 2345B AND ABOVE

NO. Column

Unique Symbols - All items with same unique symbol (*, #, +, %, or >) in the number column belong to the same assembly or kit, which is indicated by a note in the “Remarks” column.

Duplicate Item Numbers - Duplicate numbers indicate multiple part numbers are in effect for the same general item, such as different size saw blade guards in use or a part that has been updated on newer versions of the same machine.

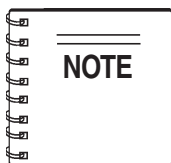

When ordering a part that has more than one item number listed, check the remarks column for help in determining the proper part to order.

PART NO. Column

Numbers Used - Part numbers can be indicated by a number, a blank entry, or TBD.

TBD (To Be Determined) is generally used to show a part that has not been assigned a formal part number at time of publication.

A blank entry generally indicates that the item is not sold separately or is not sold by Multiquip. Other entries will be clarified in the “Remarks” Column.

QTY. Column

Numbers Used - Item quantity can be indicated by a number, a blank entry, or A/R.

A/R (As Required) is generally used for hoses or other parts that are sold in bulk and cut to length.

A blank entry generally indicates that the item is not sold separately. Other entries will be clarified in the “Remarks” Column.

REMARKS Column

Some of the most common notes found in the “Remarks” Column are listed below. Other additional notes needed to describe the item can also be shown.

Assembly/Kit - All items on the parts list with the same unique symbol will be included when this item is purchased.

Indicated by:

“INCLUDES ITEMS W/(unique symbol)”

Serial Number Break - Used to list an effective serial number range where a particular part is used.

Indicated by:

“S/N XXXXX AND BELOW”

“S/N XXXX AND ABOVE”

“S/N XXXX TO S/N XXX”

Specific Model Number Use - Indicates that the part is used only with the specific model number or model number variant listed. It can also be used to show a part is NOT used on a specific model or model number variant.

Indicated by:

“XXXXX ONLY”

“NOT USED ON XXXX”

“Make/Obtain Locally” - Indicates that the part can be purchased at any hardware shop or made out of available items. Examples include battery cables, shims, and certain washers and nuts.

“Not Sold Separately” - Indicates that an item cannot be purchased as a separate item and is either part of an assembly/kit that can be purchased, or is not available for sale through Multiquip.

AR-13HA RIDE-ON ROLLER — SUGGESTED SPARE PARTS

AR-13H Ride-on Tandem Drum Roller w/Honda GX610K1QZB2 Engine 1 to 3 Units

Qty.	P/N	Description
1	510229	CABLE, THROTTLE
1	506239	CABLE, CHOKE
1	513324	CABLE, FORWARD/REVERSE
1	10958	SWITCH, STARTER
3	506267K	KEY, STARTER SWITCH
6	508667	OIL FILTER, HYDRAULIC
1	507278	CAP, HYDRAULIC TANK
1	506221	FILTER, GAS TANK
6	EM20763	FILTER, FUEL
1	34507	GAUGE, FUEL/CAP
1	509249	CAP, WATER TANK
4	508433	SCRAPER, RUBBER
3	17010ZJ1000	ELEMENT SET, AIR
1	17218ZJ1000	FILTER OUTER, AIR
6	15410ZJ4999AH	FILTER, OIL
6	9807956846	SPARK PLUG
3	16910ZE8015	FILTER, FUEL ENGINE

AR-13HA RIDE-ON ROLLER — NAME PLATE AND DECALS

NAME PLATE AND DECALS

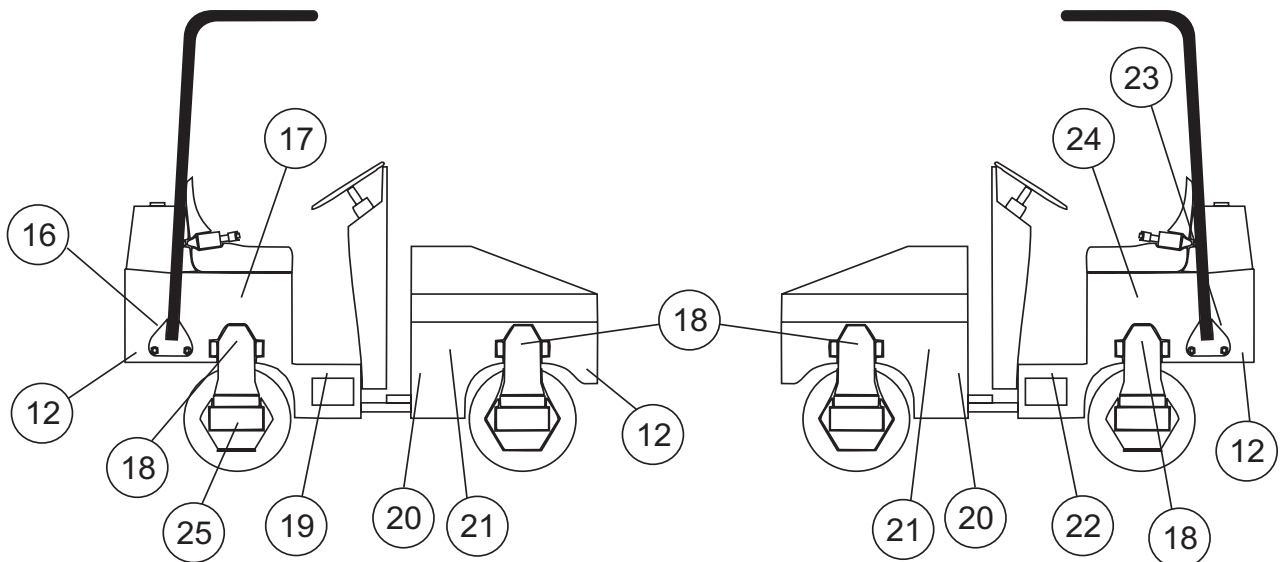
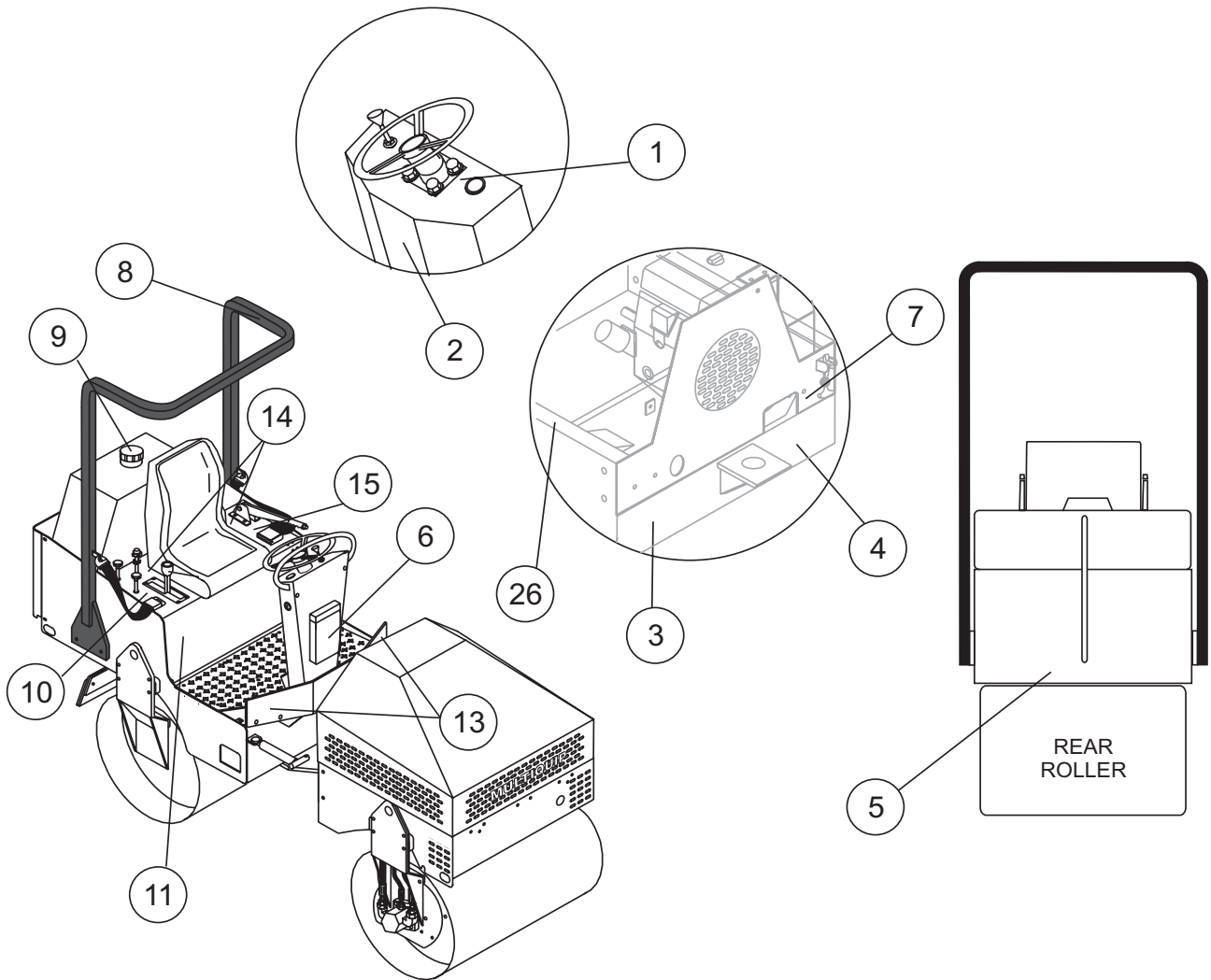

AR-13HA RIDE-ON ROLLER — NAME PLATE AND DECALS

NAME PLATE AND DECALS

<u>NO.</u>	<u>PART NO.</u>	<u>PART NAME</u>	<u>QTY.</u>	<u>REMARKS</u>
1	513457	DECAL: STEERING CONSOLE	1	
2	13118	DECAL: POWDER COATED	1	
3	511726	DECAL: HYDRAULIC OIL LEVEL INDICATOR	1	
4	511736	DECAL: WARNING	1	
5	TBD	DECAL: MULTIQUIP BANNER	1	
6	34536	DECAL: OWNERS MANUAL	1	
7	513580	DECAL: ENGINE RPM SETTING	1	
9	513698	DECAL: WATER TANK CAP	1	
10	515436	DECAL: CONTROL PANEL	1	
11	511737	DECAL: SERVICE INSTRUCTION CHART	1	
12	513393	DECAL: SECURING POINT INDICATOR	3	POINT ARROW DOWN
13	511735	DECAL: CAUTION	2	
14	513707	DECAL: ATTENTION	2	
15	513467	DECAL: PARKING BRAKE INSTRUCTIONS	1	
16	513529	DECAL: AR-13H MQ LOGO	1	
17	511738	DECAL: DANGER	1	
18	513393	DECAL: SECURING POINT INDICATOR	4	POINT ARROW UP
19	513469	DECAL: CAUTION STRIPE PATTERN	1	HORIZONTAL PLACEMENT
20	511718	DECAL: CAUTION STRIPE PATTERN	2	VERTICAL PLACEMENT
21	513658	DECAL: MQ LOGO	2	
22	513740	DECAL: CAUTION STRIPE PATTERN	1	HORIZONTAL PLACEMENT
23	513531	DECAL: AR-13H MQ LOGO	1	
24	511739	DECAL: CAUTION: INSTRUCTIONS	1	
25	511724	DECAL: GREASE REMINDER	1	
26	511733	DECAL: HYDRAULIC OIL INDICATOR	1	

AR-13HA RIDE-ON ROLLER — FRONT DRUM ASSY.

FRONT DRUM ASSY.

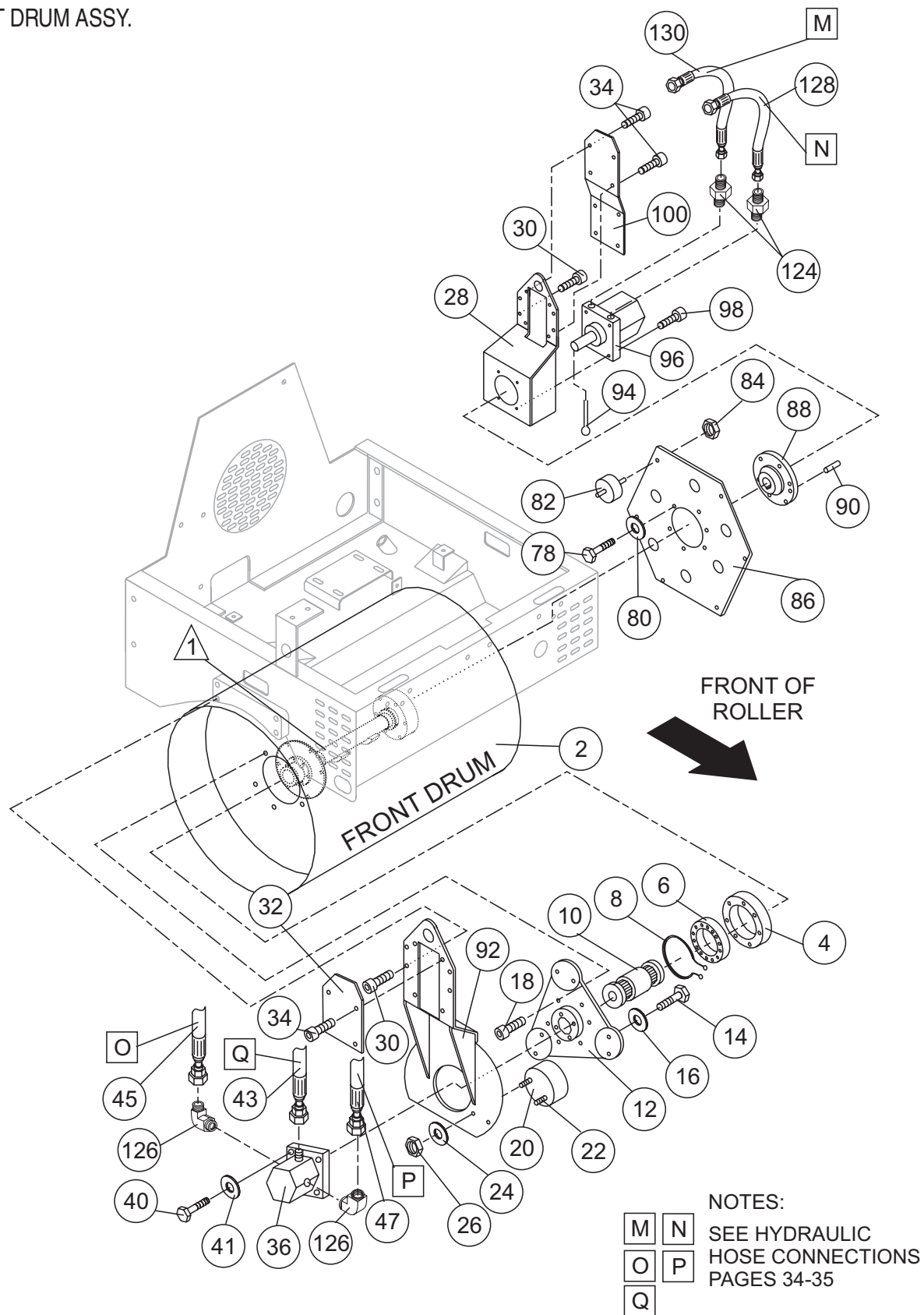

AR-13HA RIDE-ON ROLLER — FRONT DRUM ASSY.

FRONT DRUM ASSY.

<u>NO.</u>	<u>PART NO.</u>	<u>PART NAME</u>	<u>QTY.</u>	<u>REMARKS</u>
2	513280	FRONT ROLLER	1	
4	506145	HOUSING BEARING	1	
6	506147	BEARING	1	
8	506136	RING, RETAINING	1	
10	508665	COUPLER	1	
12	506142	MOUNT, VIBRATION MOTOR	1	
14	011208025	BOLT, 8X25T	6	REPLACES 508342
16	EM923023	WASHER, FLAT 5/16"	6	REPLACES 492597
18	492264	BOLT, 3/8"X1"	6	
20	506141	SHOCK, MOUNT	3	
22	508340	STUD, M8X40	6	
24	EM923343	WASHER, LOCK 5/16	6	REPLACES 492623
26	508341	NUT, M8	6	
28	515637	ROLLER, SUPPORT,	1	LEFT SIDE - FRONT/REAR
30	492276	BOLT 1/2"X1-1/2"	8	
32	513283	HOSE, PROTECTION COVER	1	
34	513314	NUT 1/4"X1/2"	12	
36	506220	MOTOR, HYDRAULIC	1	
40	492362	NUT 5/16"X5/8"	4	
41	EM923343	WASHER, LOCK 5/16" DIAMETER	4	REPLACES 492623
43	513337	HOSE	1	
45	513343	HOSE	1	
47	513342	HOSE	1	
78	EM963610	BOLT 3/8"X1"	6	REPLACES 492375
80	508346	WASHER, 3/8	6	
82	505985	SHOCK, MOUNT	6	
84	021110120	NUT, NYLON LOCK M10 ZINC 1.SP	6	
86	505977	PLATE, DRIVER	1	
88	505984	HUB	1	
90	EM503803	PINS, DOWEL	2	REPLACES 503803
92	514522	SUPPORT, ROLLER	1	RIGHT SIDE - FRONT
94	491690	KEY, COTTER 1/8"X2"	1	
96	515396	MOTOR, HYDRAULIC	1	
98	505990	BOLT 1/2"X2-1/2"	4	
100	515639	COVER	1	
124	505951	FITTING	2	
126	513332	FITTING	2	
128	515641	HOSE	1	
130	513344	HOSE	1	

AR-13HA RIDE-ON ROLLER — EXCITER ASSY.

EXCITER ASSY.

<u>NO.</u>	<u>PART NO.</u>	<u>PART NAME</u>	<u>QTY.</u>	<u>REMARKS</u>
44	EM963610	CAPSCREW, 3/8"N X 1-1/4"G5	6	
46	508346	WASHER, 3/8"	12	
48	513285	HOUSING, BEARING RIGHT	1	
52	EM927040	KEY, WOODRUFF 606	1	REPLACES 506250
54	492467	SCREW, ALLEN 5/16"	2	
58	EM963610	CAPSCREW, 3/8"	6	REPLACES 492375
60	506144	SEAL	1	
62	490964	RING, RETAINING	1	
64	506131	BEARING	2	
66	513418	EXCITER SHAFT	1	
70	506135	RING, RETAINING	2	
74	513286	OIL SEAL 65x100x9	2	
76	513287	HOUSING, BEARING LEFT	1	

AR-13HA RIDE-ON ROLLER — REAR DRUM & CHASSIS ASSY.

REAR DRUM & CHASSIS ASSY.

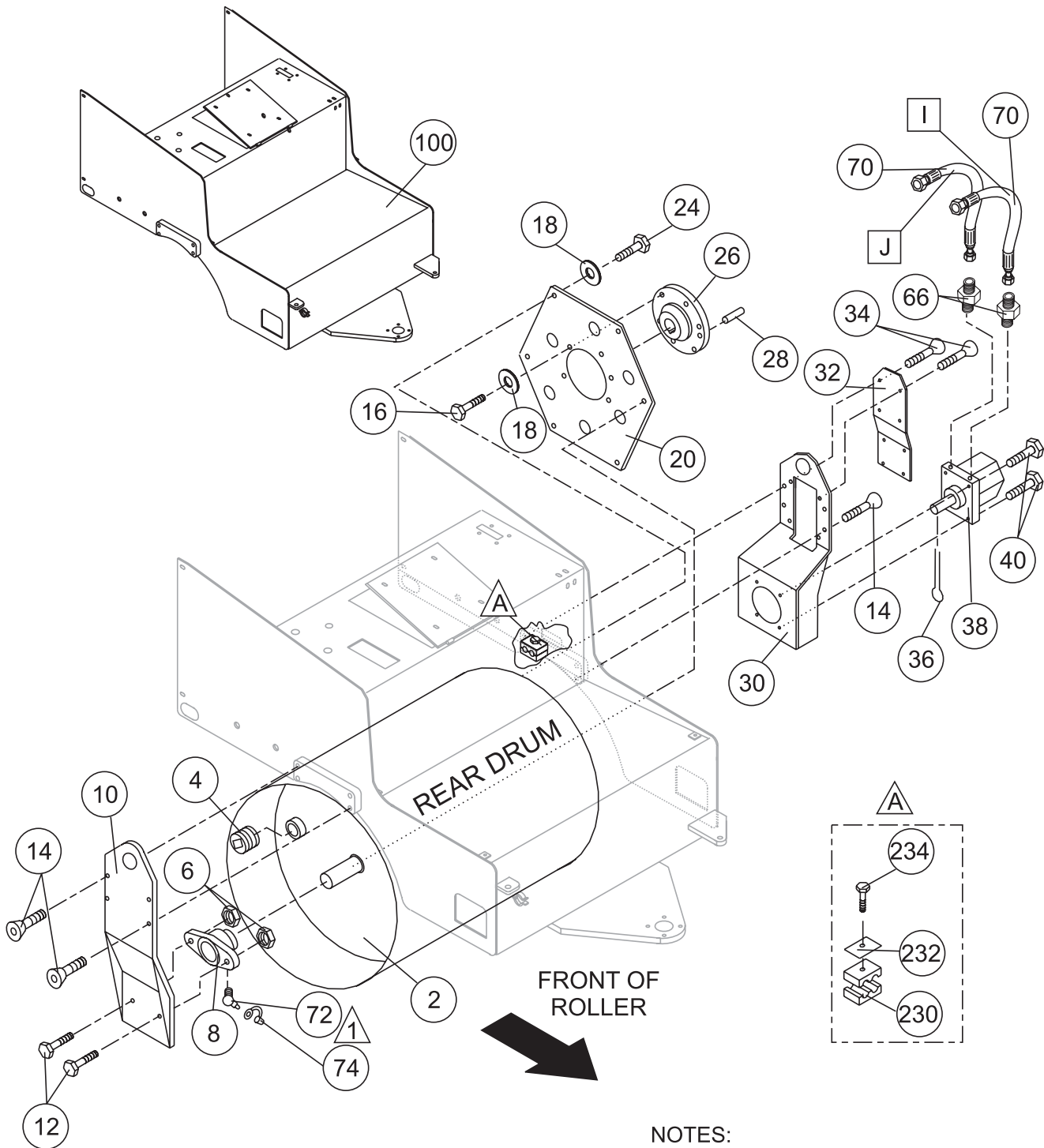

NOTES:

I J SEE HYDRAULIC HOSE CONNECTIONS PAGE 34-35

▲ ITEMS 72 AND 74 ARE INCLUDED WITH ITEM 8 (BEARING, FLANGE) AND CANNOT BE SOLD SEPARATELY.

AR-13HA RIDE-ON ROLLER — REAR DRUM & CHASSIS ASSY.

REAR DRUM & CHASSIS ASSY.

<u>NO.</u>	<u>PART NO.</u>	<u>PART NAME</u>	<u>QTY.</u>	<u>REMARKS</u>
2	513291	REAR DRUM	1	
4	505988	ALLEN PLUG	1	
6	492584	NUT, LOCK 1/2 IN.	1	
8	503735	BEARING, FLANGE	1	INCLUDES ITEMS W/*
10	514523	SUPPORT, ROLLER	1	RIGHT SIDE - REAR
12	509165	BOLT, 1/2 NC x 2-1/4 IN. G5	1	
14	492276	BOLT, 1/2 NC x 1-1/2 IN. G5	8	
16	EM963610	CAPSCREW, 3/8 IN. NC x 1-1/4 IN. G5	6	
18	508346	LOCK WASHER 3/8 IN.	6	
20	505977	PLATE DRIVE	1	
24	EM963610	CAPSCREW, 3/8 NC x 1-1/4 IN. G8	6	REPLACES 492375
26	505984	HUB	1	
28	EM503803	PINS, DOWEL 3/8 x 1 IN.	2	
30	515637	REAR ROLLER SUPPORT, LEFT	1	LEFT SIDE - FRONT/REAR
32	515639	SUPPORT COVER	1	
34	513314	BOLT, 1/4 NC x 1/2 IN. G	12	
36	491689	KEY, COTTER 1/8 x 2 IN.	1	
38	515396	MOTOR, HYDRAULIC	1	
40	505990	BOLT, 1/2 NC x 2-1/2 IN. G	4	
66	505951	FITTING 8-10-F5OLO-S	2	
70	513349	HOSE	2	
72 *		ZERK GREASE FITTING	1	CANNOT BE SOLD SEPARATELY
74 *		ZERK CAP	1	CANNOT BE SOLD SEPARATELY
100	513266	REAR CHASSIS	1	

AR-13HA RIDE-ON ROLLER — COVERS AND FRAME ARTICULATION LOCK ASSY.

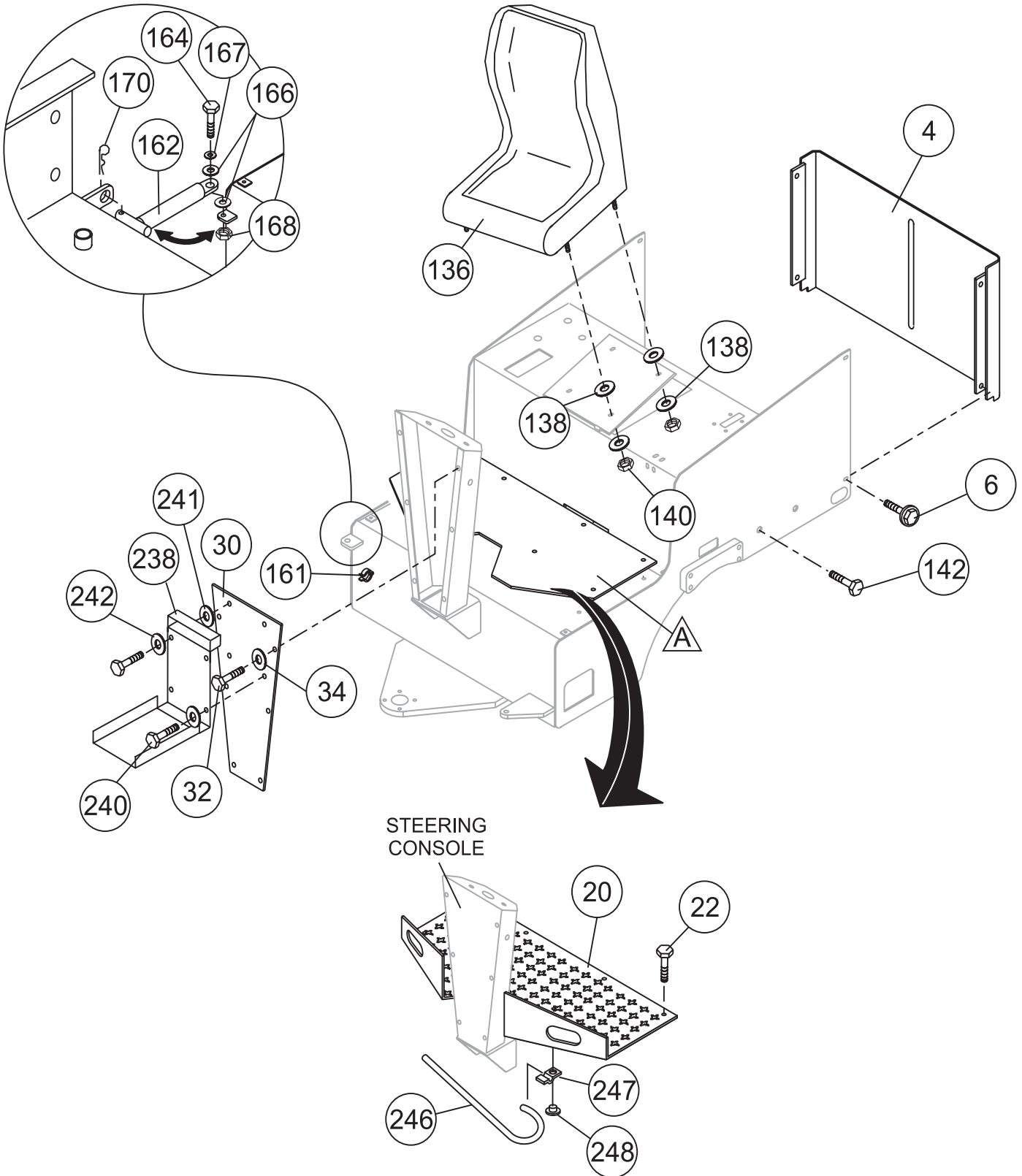

AR-13HA RIDE-ON ROLLER — COVERS AND FRAME ARTICULATION LOCK ASSY.

COVERS AND FRAME ARTICULATION LOCK ASSY.

<u>NO.</u>	<u>PART NO.</u>	<u>PART NAME</u>	<u>QTY.</u>	<u>REMARKS</u>
4	513315	REAR WATER TANK COVER	1	
6	509177	BOLT 5/16 IN.	4	
20	515416	FLOOR PLATE/W ALUMINUM COVER	1	
22	509177	BOLT 5/16 X 5/8 IN.	10	
32	492363	BOLT 5/16 X 3/4 IN. NCG5	6	
34	EM923343	WASHER, LOCK 5/16 IN.	6	REPLACES 492623
136	507888	SEAT	1	
138	505679	NUT 5/16"	8	
140	2105164	NUT, NYLON 5/16 IN. - 18	4	REPLACES 492582
161	513471	LOCK CLIP	4	
162	513328	LOCKING ARM	1	
164	492410	BOLT 5/8 NC x 2-1/2 IN. G5	1	
166	506167	WASHER, PLASTIC 5/8 IN.	2	
167	EM923023	WASHER, PLAIN 5/16 IN.	1	REPLACES 506109
168	EM969023	NUT, LOCK 5/8 IN.	1	REPLACES 492586
170	745	LOCK PIN	1	
238	29057	DOCUMENT BOX	1	
240	492357	SCREW, HHC 1/4 IN.- 20X12	4	
241	504451	WASHER 1/4 IN.	4	
242	492596	WASHER 1/4 IN.	8	
243	509177	BOLT 5/16 NC X 5/8 IN. G5	2	
244	515416	ALUMINUM FLOOR COVER	1	
246	515415	ARM, FLOOR COVER	1	
247	511474	BRACKET, ARM	1	
248	503723	RIVET AM-54	1	

AR-13HA RIDE-ON ROLLER — HOOD AND REAR PANEL ASSY.

HOOD AND REAR PANEL ASSY.

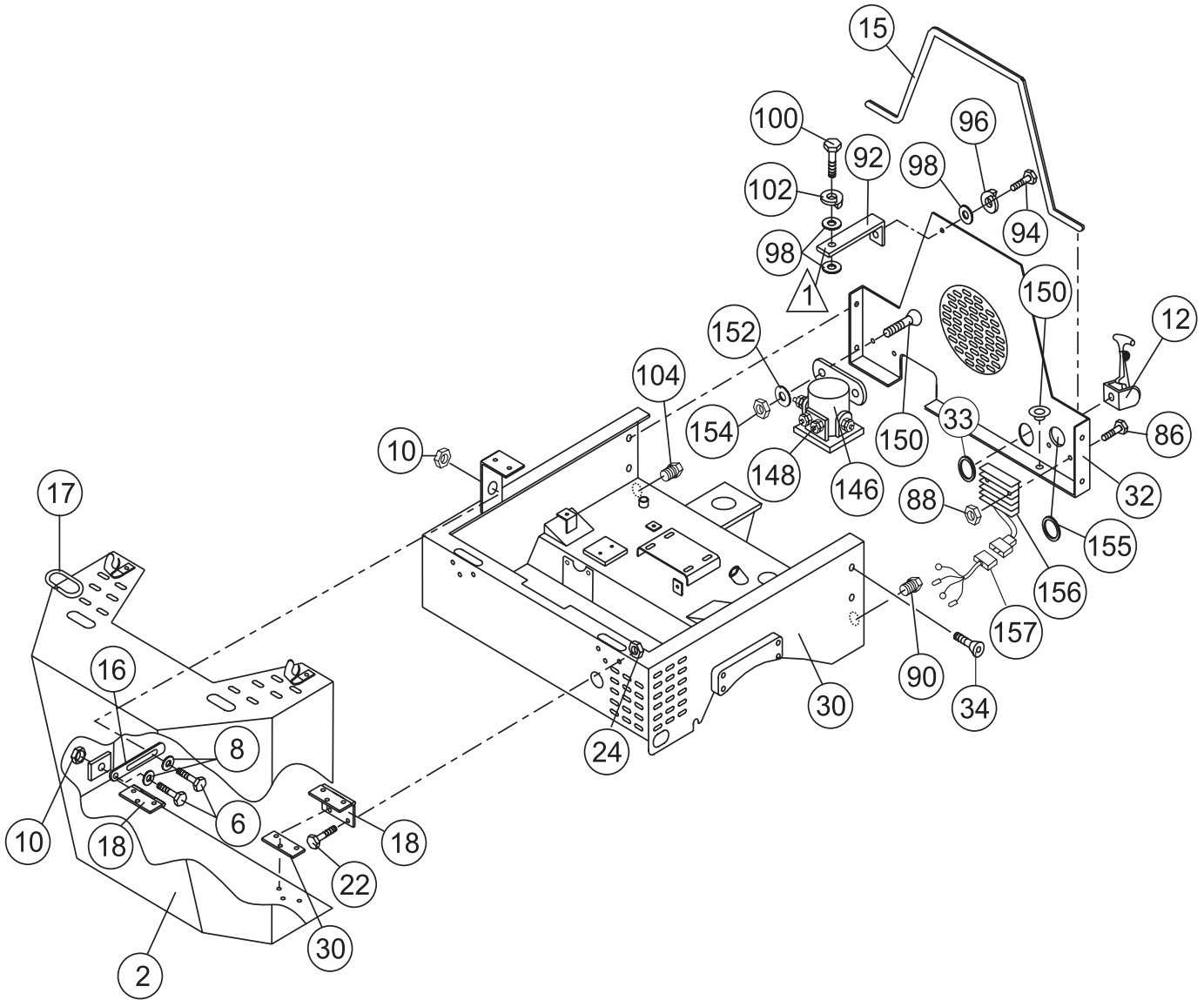

NOTES:

① SECURE TO ENGINE

AR-13HA RIDE-ON ROLLER — HOOD AND REAR PANEL ASSY.

HOOD AND REAR PANEL ASSY.

<u>NO.</u>	<u>PART NO.</u>	<u>PART NAME</u>	<u>QTY.</u>	<u>REMARKS</u>
2	515096	HOOD	1	
6	492364	SCREW, HHC 5/16 X 18 X 1 IN.	2	
8	505679	FLAT WASHER 5/16 IN.	2	
10	2105164	NUT, NYLON 5/16- 18	2	REPLACES 492582
12	491010	LATCH KIT	2	REPLACES 504744
13	503723	RIVET BRAKE LINING	13	
15	515199	SEAL RUBBER	1	
16	513305	HINGE, SLOTTED	1	
18	514438	LATCH KIT (HOOD)	1	
22	492356	BOLT 1/4 X 3/4 IN.	12	
24	492581	NUT 1/4 IN.	12	
30	513396	FRONT CHASSIS	1	
32	513308	REAR ENGINE COVER	1	
33	13212	GROMMET, 1-1/4 IN. ID	1	
34	513309	BOLT 5/16 X 3/4 IN.	4	
86	513312	BOLT 1/4 X 1 IN.	2	
88	492581	NUT 1/4 IN.	2	
90	490181	SIGHT GLASS	1	
92	513313	SUPPORT REAR ENGINE COVER	1	
94	492356	BOLT 1/4 X 3/4 IN.	1	
96	2101402	WASHER, LOCK 1/4 IN.	1	REPLACES 492622
98	492596	FLAT WASHER 1/4 IN.	3	
100	011208025	BOLT 8 X 25T DCA-85,125,150SSM	1	REPLACES 508342
102	EM923343	WASHER, LOCK 5/16 IN.	1	REPLACES 492623
104	506205	PLUG	1	
146	506273	SOLENOID, STARTER	1	
148	510925	NUT 3/16 IN.	2	
150	513314	BOLT 1/4 X 1/2 IN.	2	
152	492596	FLAT WASHER 1/4 IN.	2	
154	492581	NUT 1/4 IN.	2	
155	506085	GROMMET	1	
156	31620ZG5003	RECTIFIER ASSY, REGULATOR , 20A	1	
157	32105ZJ1800	SUB-WIRE HARNESS ASSY.	1	

AR-13H — STEERING COLUMN AND HYDRAULIC ARTICULATION ASSY.

STEERING COLUMN AND HYDRAULIC ARTICULATION ASSY.

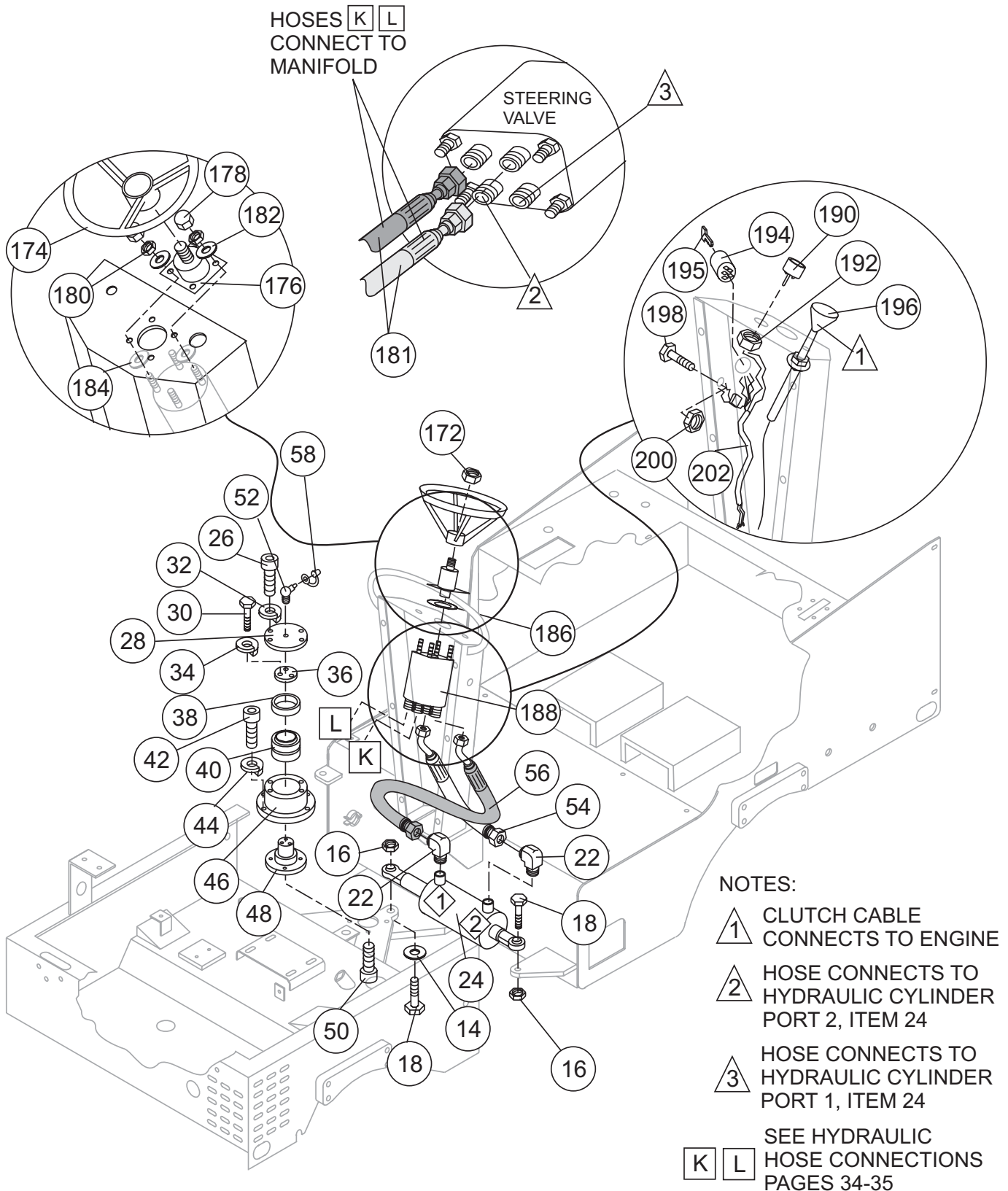

AR-13H — STEERING COLUMN AND HYDRAULIC ARTICULATION ASSY.

STEERING COLUMN AND HYDRAULIC ARTICULATION ASSY.

<u>NO.</u>	<u>PART NO.</u>	<u>PART NAME</u>	<u>QTY.</u>	<u>REMARKS</u>
14	EM923348	WASHER, LOCK 5/8 IN.	2	
16	EM969023	NUT, LOCK 5/8 IN.	2	REPLACES 492586
18	492412	BOLT 5/8" UNC X 3	2	
22	506196	ELBOW FITTING	2	
24	513297	CYLINDER, STEERING	1	
26	513298	BOLT 1/2 IN. NC x 1 IN. G	4	
28	513229	COVER, ARTICULATING JOINT	1	
30	EM963055	HEX HEAD CAPSCREW 3/8 IN. x 3/4 IN.	3	REPLACES 492373
32	6109180	WASHER, LOCK 1/2" DIAMETER	4	REPLACES 492626
34	0166A	WASHER, LOCK 3/8" DIAMETER	3	REPLACES 492624
36	513300	RETAINER PLATE	1	
38	513301	SPACER	1	
40	506164	BEARING	1	
42	492276	BOLT 1/2 IN. NC x 1-1/2 IN. G	4	
44	6109180	WASHER, LOCK 1/2 IN.	4	REPLACES 492626
46	513302	BASE, ARTICULATING JOINT	1	
48	513303	ARTICULATING JOINT	1	
50	492276	BOLT 1/2 IN. NC x 1-1/2 IN. G	4	
52	491701	ZERK FITTING	1	
54	513350	HOSE, 9	1	
56	513348	HOSE, 16	1	
58	491008	GREASE COVER	1	
172	598156	NUT	1	
174	493128	WHEEL, STEERING	1	
176	507862	STEERING COLUMN	1	
178	506265	NUT 5/16 IN.	4	
180	509143	NUT 5/16 IN.	4	
181	513346	HOSES K AND L	2	
182	508344	WASHER 5/16 IN.	4	
184	508335	BUSHING	4	
186	509190	WASHER 3/4 IN.	1	
188	506186	HYDRAULIC VALVE	1	
190	506222	HOUR METER	1	
192	503119	NUT, LOCK 3/16"	1	
194	10958	SWITCH, STARTER	1	
195	506267K	KEY, IGNITION	1	
196	506239	CABLE CHOKE	1	
198	503958	BOLT 1/4 IN. x 5/8 IN. G5	1	
200	EM969079	NUT 1/4 IN.	1	REPLACES 492581
202	513330	HARNESS, WIRING	1	

AR-13HA RIDE-ON ROLLER — ARTICULATION ARM ASSY.

ARTICULATION ARM

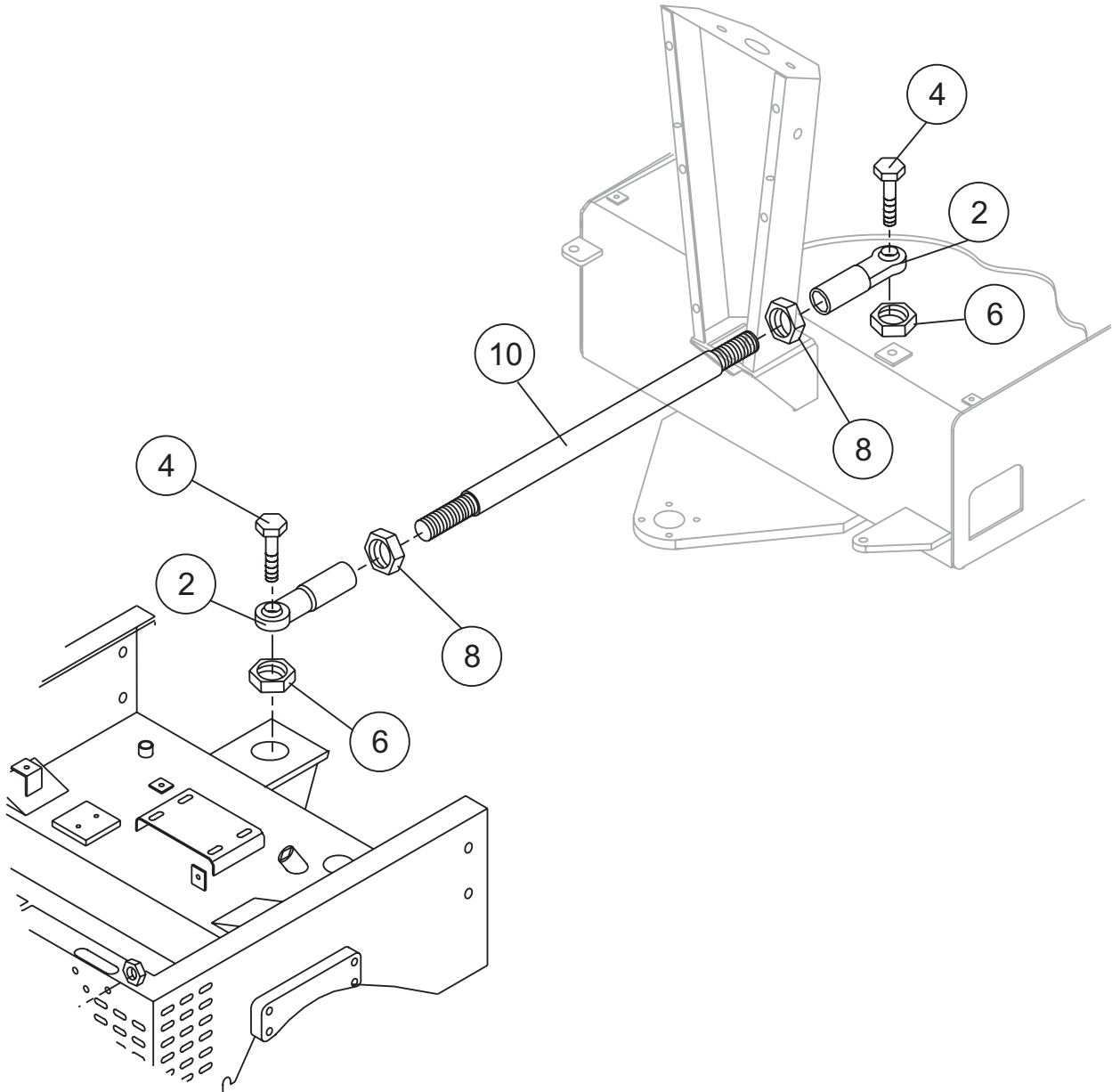

AR-13HA RIDE-ON ROLLER — ARTICULATION ARM ASSY.

ARTICULATION ARM

<u>NO.</u>	<u>PART NO.</u>	<u>PART NAME</u>	<u>QTY.</u>	<u>REMARKS</u>
2	513294	ROD END	2	
4	514347	BOLT 3/4 IN. x 2-1/2 IN.	2	
6	EM505069	NUT 3/4 IN.	2	
8	513295	NUT 3/4 IN.	2	
10	513296	ROD, DIRECTION STABILIZER	1	

AR-13HA RIDE-ON ROLLER — HYDRAULIC DRIVE PUMP ASSY.

HYDRAULIC DRIVE PUMP ASSY.

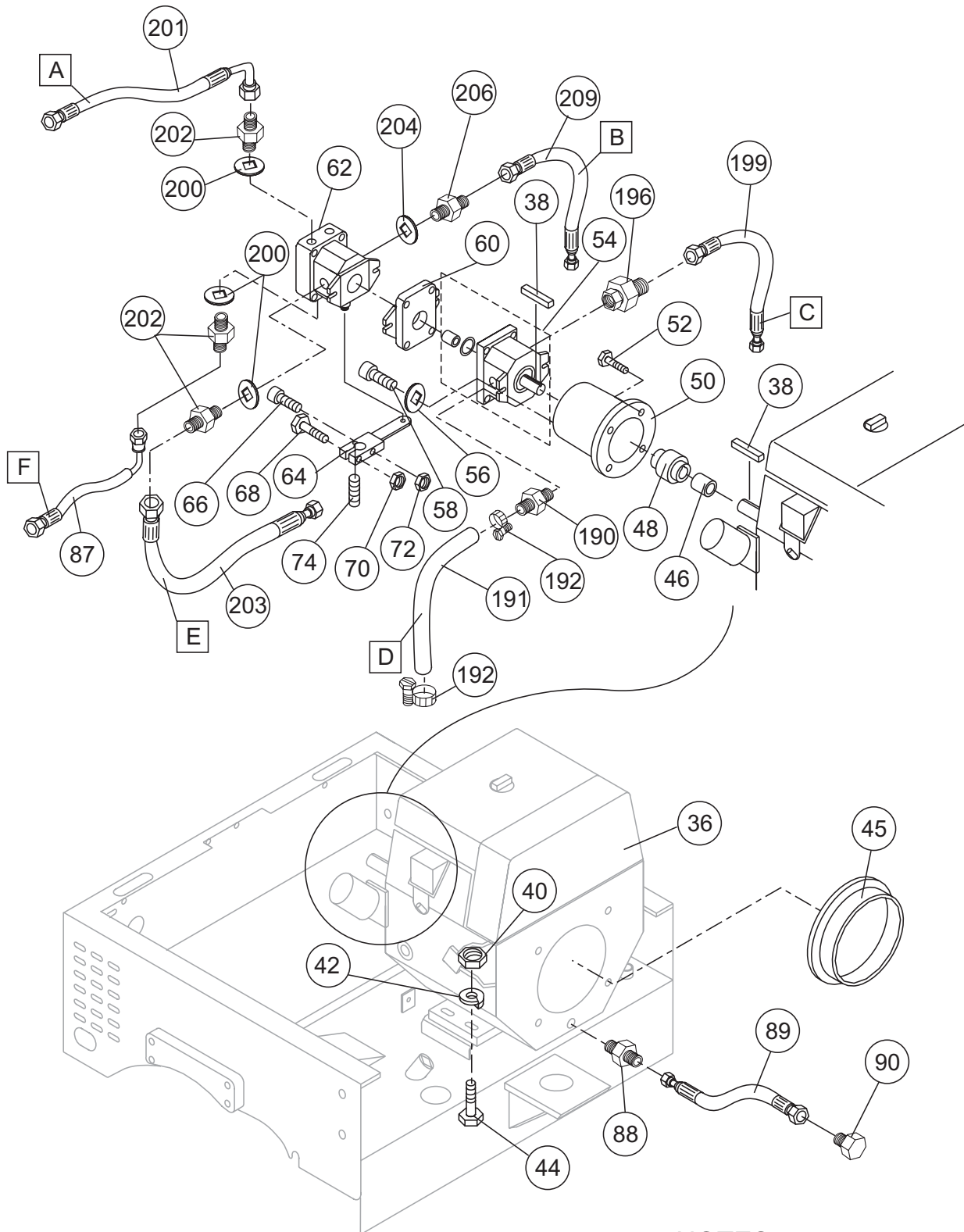

NOTES

- | | | | |
|---|---|---|------------------|
| A | C | A | SEE HYDRAULIC |
| B | D | B | HOSE CONNECTIONS |

AR-13HA RIDE-ON ROLLER — HYDRAULIC DRIVE PUMP ASSY.

HYDRAULIC DRIVE PUMP ASSY.

<u>NO.</u>	<u>PART NO.</u>	<u>PART NAME</u>	<u>QTY.</u>	<u>REMARKS</u>
36	GX610K1QZB2	ENGINE W/ELECTRIC STARTER	1	
38	500214	KEY SQUARE	1	
40	EM969013	NUT LOCK 3/8 IN.	4	REPLACES 492583
42	3019092	WASHER, FLAT 3/8 IN.	8	REPLACES 492598
44	EM963059	BOLT 3/8 X 2 IN.	4	REPLACES 492379
45	513352	RUBBER RING 1/2 X 1/2 IN.	1	
46	506234	SPACER	1	
48	506235	COUPLER	1	
50	506236	ALUMINUM ADAPTER	1	
52	EM963610	CAPSCREW 3/8 NCX 1-1/4 IN. GS	4	REPLACES 492376
54	507845	PUMP, STEERING	1	
56	EM508346	WASHER 3/8 IN.	2	REPLACES 508346
58	EM175	BOLT 3/8-16 X 1-1/4 SC HD	2	
60	507860	ADAPTER, STEERING PUMP	1	
62	506187	HYDRAULIC PUMP	1	
64	513310	SHIFT LEVER	1	
66	509144	BOLT 3/16 X 1-3/4 IN.	1	
68	492367	BOLT 5/16 X 1-3/4 IN.	1	
70	2105164	NUT, NYLON 5/16 IN. - 18	1	REPLACES 492582
72	503119	NUT, LOCK 3/16 IN.	1	
74	492465	SCREW ALLEN HEAD 1/4 - 20 X 3/8 IN.	1	
87	513335	HOSE	2	
88	513618	ADAPTOR	1	
89	513620	HOSE, DRAIN	1	
90	513619	PLUG	1	
190	506217	FITTING 3/4 IN.	1	
191	513340	HOSE	1	
192	506207	HOSE CLAMP, HS-16	2	
196	506203	FITTING	1	
199	513338	HOSE	1	
200	508427C	COPPER WASHER 21/32 IN.	3	
201	513333	HOSE	1	
202	508343	FITTING	3	
203	513339	HOSE	1	
204	508428C	COPPER WASHER 5/8 IN.	1	
206	506219	FITTING 1/2 IN.	1	
208	506200	FITTING 3703-08-08	1	
209	513336	HOSE	1	

AR-13HA RIDE-ON ROLLER — MANIFOLD AND HYDRAULIC OIL FILTER

MANIFOLD AND HYDRAULIC OIL FILTER ASSY.

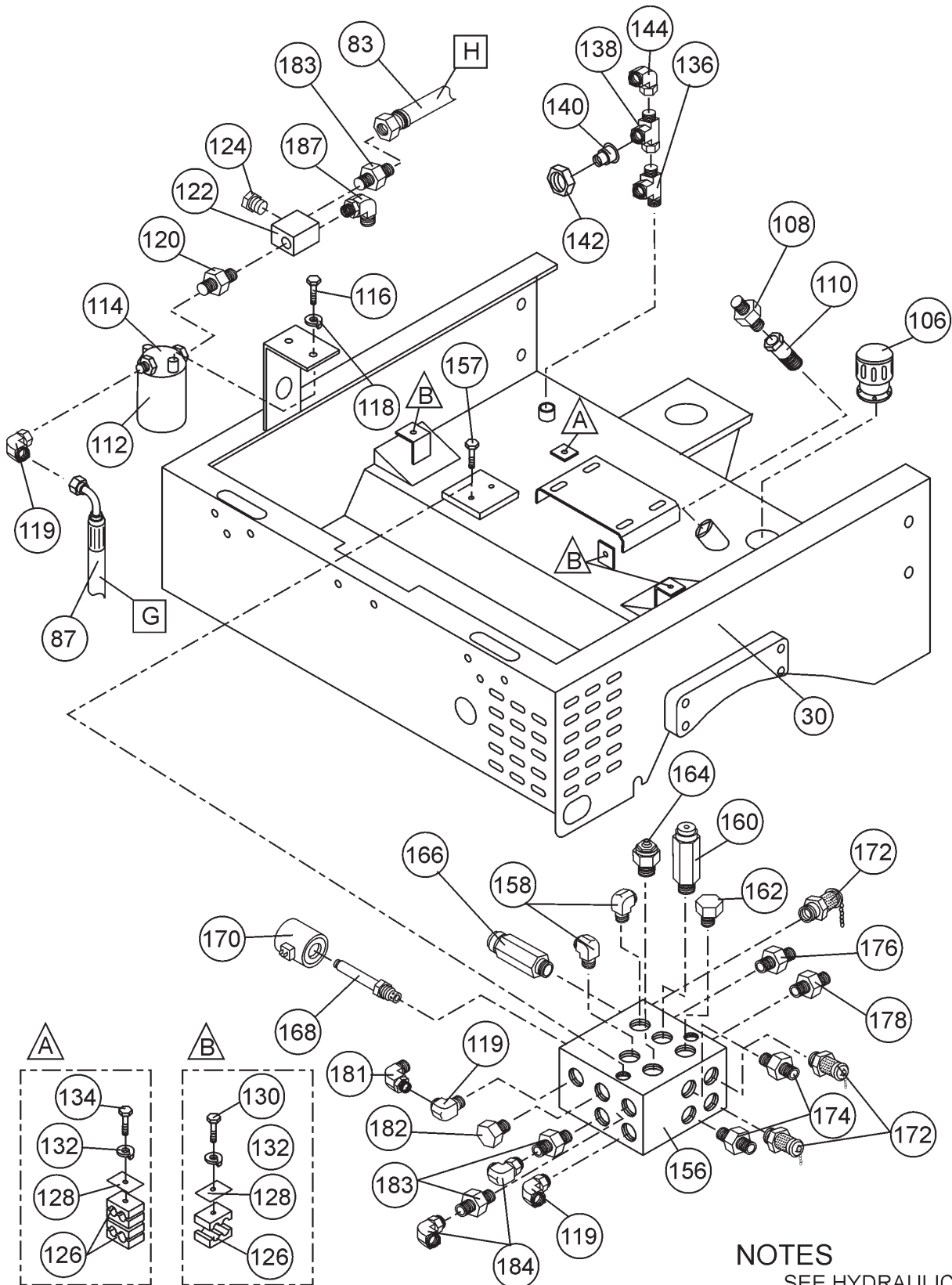

NOTES

G **H** SEE HYDRAULIC HOSE CONNECTIONS PAGE 34-35

AR-13HA RIDE-ON ROLLER — MANIFOLD AND HYDRAULIC OIL FILTER

MANIFOLD AND HYDRAULIC OIL FILTER ASSY.

<u>NO.</u>	<u>PART NO.</u>	<u>PART NAME</u>	<u>QTY.</u>	<u>REMARKS</u>
83	513334	HOSE	1	
87	513335	HOSE	2	
106	507278	HYDRAULIC TANK CAP	1	
108	506218	STRAIGHT FITTING 3/4"	1	
110	506221	FILTER, GAS	1	
112	508667	OIL FILTER	1	
114	508664	FILTER, HEAD	1	
116	492357	SCREW HHC 1/4- 20X12	2	
118	2101402	WASHER, LOCK 1/4"	2	REPLACES 492622
119	EM25507	FITTING	3	
120	506204	FITTING	1	
122	506244	BLOCK FILTER M10	1	
124	508670	VALVE CHECK	1	
126	505976	CLAMP 3/4	5	
128	506185	PLATE CORNER	4	
130	492367	SCREW, HHC 5/16"-18X1-3/4"	3	
132	EM923343	WASHER, LOCK 5/16"	4	REPLACES 492623
134	492371	BOLT 5/16" LOCK	1	
136	506201	FITTING, TEE	1	
138	506202	FITTING	2	
140	506206	FITTING	1	
142	508472	FITTING	1	
144	506195	FITTING	1	
156	515502	MANIFOLD	1	
157	508814	BOLT 5/16"X3-1/4"	2	
158	506192	FITTING	2	
160	507774	VALVE RELIEF, 500 PSI	1	
162	507772	PLUG	1	
164	506247	VALVE, NEEDLE	1	
166	506246	VALVE, RELIEF, 2000 PSI	1	
168	506245	VALVE, SOLENOID	1	
170	507885	12 VOLT COIL SOLENOID	1	
172	506182	COUPLING PSI TEST	3	
174	506190	FITTING	2	
176	511808	ADAPTER, STRAIGHT	2	
178	506190	FITTING	2	
181	506195	FITTING	1	
182	506205	PLUG	1	
183	506193	FITTING	4	
184	506195	FITTING	2	

AR-13HA RIDE-ON ROLLER — FUEL TANK ASSY.

FUEL TANK ASSY.

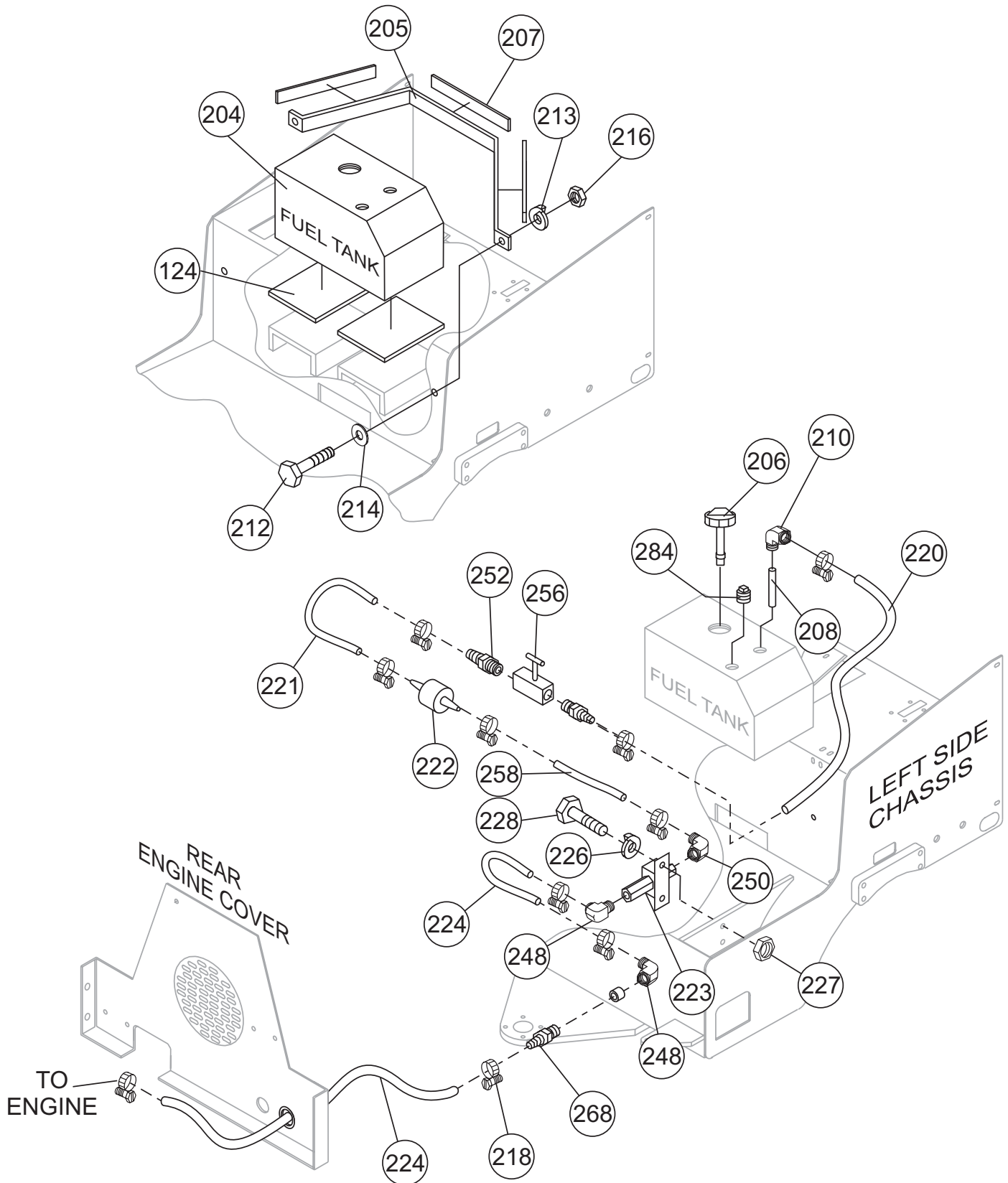

AR-13HA RIDE-ON ROLLER — FUEL TANK ASSY.

FUEL TANK ASSY.

<u>NO.</u>	<u>PART NO.</u>	<u>PART NAME</u>	<u>QTY.</u>	<u>REMARKS</u>
124	508302	PAD, RUBBER TANK	2	
204	513329	FUEL TANK	1	
205	514467	BRACKET, FUEL TANK SUPPORT	1	
206	34507	CAP, FUEL W/GAUGE	1	
207	514340	PAD, RUBBER BRACKET 4 x 36 x 10 mm	1.7	
208	491210	FLEX TUBE 5/16 IN.	1	
210	505521	ADAPTER, ELBOW	1	
212	492309	BOLT 5/16 NC x 1 IN. G5	2	
213	492623	WASHER, LOCK 5/16 IN.	2	
214	3019092	WASHER, FLAT 5/16 IN.	2	
216	492553	NUT, HEX 5/16 IN.	2	
218	506208	CLAMP HS-4	8	
220	514536	HOSE 4FLH 5/16 IN.	.85	
221	20427	HOSE 4FLH 5/16 IN.	.07	
222	EM20763	FUEL, FILTER	1	REPLACES 20763
223	40177	FUEL PUMP	1	
224	20427	HOSE 4FLH 5/16 IN.	.19	
226	492622	WASHER, LOCK 1/4 IN.	2	
227	492561	NUT, HEX 1/4 IN.	2	
228	492357	BOLT 1/4 NC x 1 IN. G5	2	
230	404976	CLAMP 3/4	1	
248	EM20426	ADAPTOR, ELBOW	2	
250	514559	ADAPTOR, ELBOW	1	
252	512731	ADAPTOR	2	
256	512722	FUEL SHUT-OFF VALVE	1	
258	20427	HOSE 4FLH 5/16 IN.	.07	
268	511778	ADAPTER	1	
284	491210	PLUG, TANK 1/4 IN.	1	

AR-13HA RIDE-ON ROLLER — WATER TANK ASSY.

WATER TANK ASSEMBLY ASSY.

<u>NO.</u>	<u>PART NO.</u>	<u>PART NAME</u>	<u>QTY.</u>	<u>REMARKS</u>
8	513316	WATER TANK	1	
10	EM963055	BOLT 3/8"X3/4"	1	REPLACES 492373
12	3019092	WASHER, FLAT 3/8" SPECIAL	1	REPLACES 492598
13	0166A	WASHER, LOCK 3/8"	1	REPLACES 492624
14	509249	WATER TANK CAP	1	
16	506094	PLUG 1/2" NPT GALVANIZED	1	
18	506071	ELBOW PVC	7	
84	513321	WATER VALVE EXTENSION	1	
88	492358	BOLT 1/4" NC x 1-1/4" G5	4	
90	492581	NUT 1/4"	4	
92	513322	VALVE, BALL	2	
93	813351	ELBOW 90G 1/2" NYLON	1	
94	513379	"T" ADAPTER	1	
98	506086	U- BOLT 3/8"	4	
100	3019092	WASHER, FLAT. 3/8"	16	REPLACES 492598
102	508435	LOCK NUT	8	
104	503015	KNOB, HANDLE ADJ.	2	
116	504163	HOSE 1/2"	1	
118	504163	HOSE 1/2"	1	
119	504163	HOSE 1/2"	1	
120	504163	HOSE 1/2"	1	
122	504163	HOSE 1/2"	1	
128	506084	CLAMP	4	
130	505679	NUT 5/16"	4	
132	505401	SCREW, HHC 5/16" - 18X1/2"	4	
266	506072	PVC TUBE	4	
268	506074	MALE ADAPTER	4	
270	508610	CAP	4	

AR-13HA RIDE-ON ROLLER — MUFFLER ASSY.

MUFFLER ASSY.

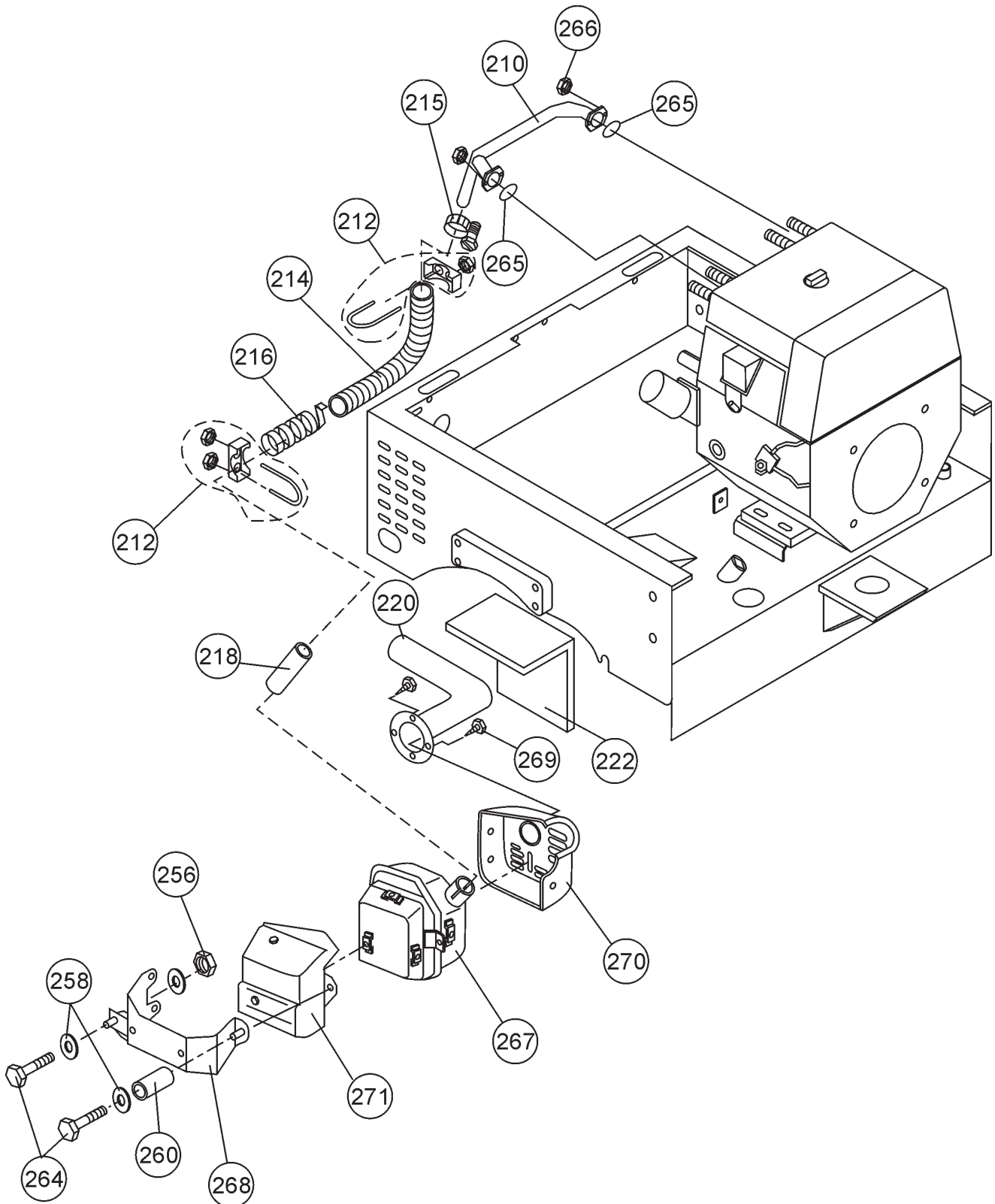

AR-13HA RIDE-ON ROLLER — MUFFLER ASSY.

MUFFLER ASSY.

<u>NO.</u>	<u>PART NO.</u>	<u>PART NAME</u>	<u>QTY.</u>	<u>REMARKS</u>
210	513449	MUFFLER PIPE (MODIFIED)	1	
212	506257	U- BOLT ASSY. 1-1/2"	2	
214	514711	TUBE 1.25" FLEX	1	
215	506207	HOSE CLAMP HS-16	2	
216	510718	HEAT WRAP 2"x1/16"	1	
218	513447	EXTENSION MUFFLER PIPE	1	
220	513444	ELBOW, EXHAUST FLANGED	1	
222	513341	DEFLECTOR EXHAUST	1	
256	492553	NUT, HEX 5/16" NC	2	
258	505679	FLAT WASHER 5/16"	4	
260	513520	MUFFLER BASE EXTENSION	1	
262	492369	SCREW, HHC5/16"- 18X2-1/4	1	
264	503952	BOLT 5/16" X4"	1	
265	18333ZJ1000	GASKET, MUFFLER	2	
266	9405008000	NUT	4	
267	18310ZJ1-800	MUFFLER	1	
268	18338ZJ1801	STAY, MUFFLER.....	1	REPLACES 18338ZJ1800
269	90009ZJ1801	SCREW, SPECIAL	4	
270	18321ZJ1801	PROTECTOR MUFFLER	1	REPLACES 18321ZJ1800
271	18325ZJ1801	PROTECTOR RR. MUFFLER	1	REPLACES 18325ZJ1800

AR-13HA RIDE-ON ROLLER — THROTTLE ASSY.

THROTTLE ASSY.

<u>NO.</u>	<u>PART NO.</u>	<u>PART NAME</u>	<u>QTY.</u>	<u>REMARKS</u>
106	513323	TRAVEL LEVER (FWD/REV)	1	
108	513324	CABLE, FORWARD/REVERSE	1	
110	514742	JOINT BALL	1	
112	508451	LOCK NUT 1/4" - 28 NF	1	
114	513325	ADVANCE CABLE SUPPORT	1	
134	510229	CABLE THROTTLE ASSEMBLY	1	
135	DY160701	KNOB HANDLE	1	
136	DA1252	LEVER HANDLE	1	

AR-13HA RIDE-ON ROLLER — BRAKE CONTROL ASSY.

BRAKE CONTROL ASSY.

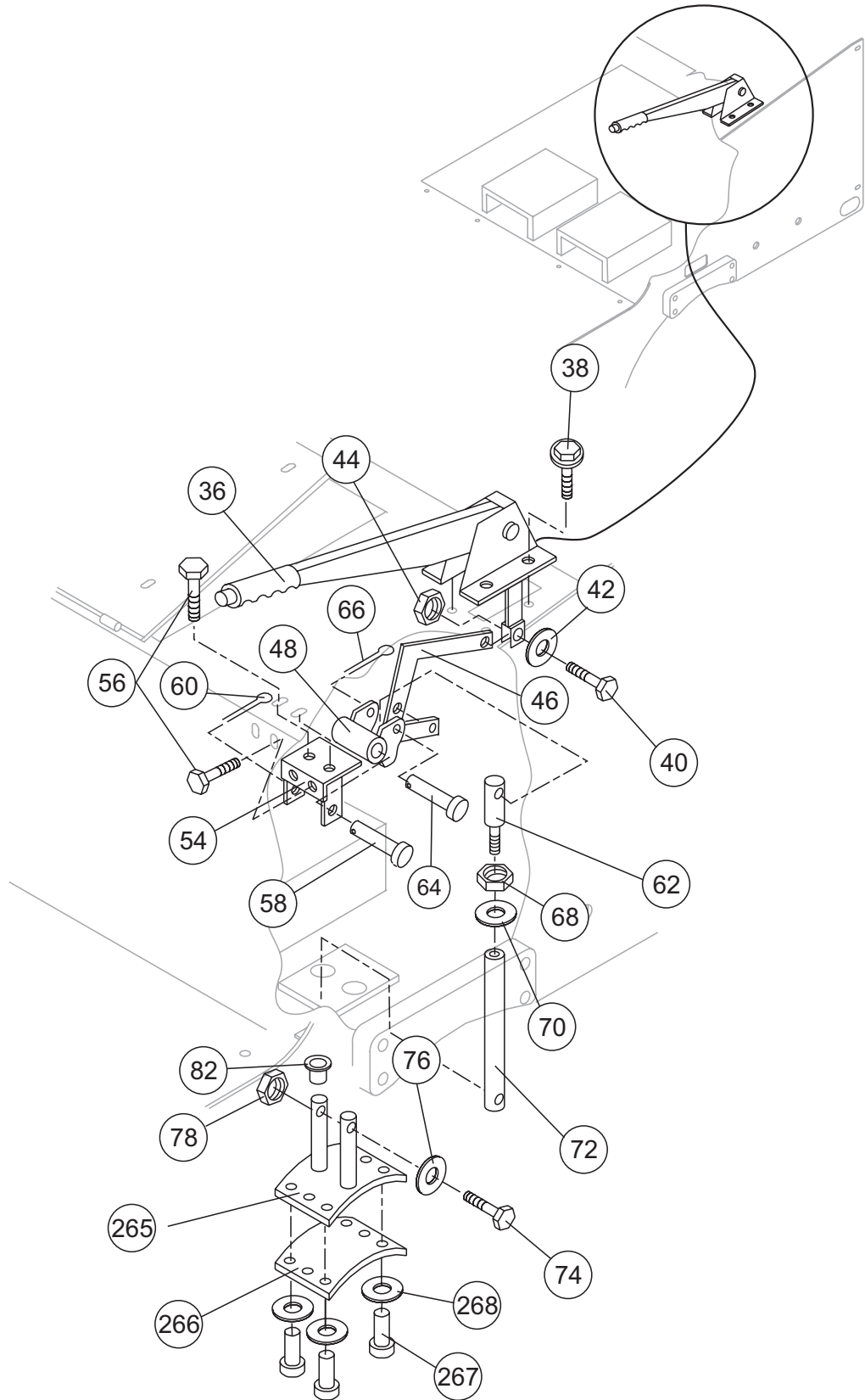

AR-13HA RIDE-ON ROLLER — BRAKE CONTROL ASSY.

BRAKE CONTROL ASSY.

<u>NO.</u>	<u>PART NO.</u>	<u>PART NAME</u>	<u>QTY.</u>	<u>REMARKS</u>
36	506046	LEVER, BRAKE	1	
38	506158	BOLT 5/16" NC x 3/4" G5	4	
40	492365	BOLT 5/16" NC x 1/1/4" G5	1	
42	EM923023	WASHER, FLAT 5/16"	2	REPLACES 492597
44	2105164	NUT, NYLON 5/16"- 18	1	REPLACES 492582
46	506057	BRAKE LINK	1	
48	505999	BELL CRANK	1	
50	EM963097	BOLT 3/8" NC x 1/1/2" G5	1	REPLACES 492313
52	EM969013	NUT, LOCK 3/8"	1	REPLACES 492583
56	508674	BOLT 5/16" NC x 1" G5	4	
58	506042	PIN, CLEVIS	1	
66	2219	KEY, COTTER	1	
68	492570	NUT, HEX 5/8"	1	
70	EM923348	WASHER, LOCK 5/8"	1	REPLACES 492627
72	508449	BRAKE ROD	1	
74	508619	BOLT, HEX HEAD 3/8" NCX4"	1	
76	3019092	WASHER, FLAT 3/8"	2	REPLACES 492598
78	EM969013	NUT, LOCK 3/8"	1	REPLACES 492583
82	506001	BUSHING, PLASTIC	1	
265	513320	SUPPORT, BRAKE SHOE	1	
266	505997	BRAKE PAD	1	
267	508566	RIVET	6	
268	508386	WASHER 3/16"	6	

AR-13HA RIDE-ON ROLLER — BATTERY ASSY.

BATTERY ASSY.

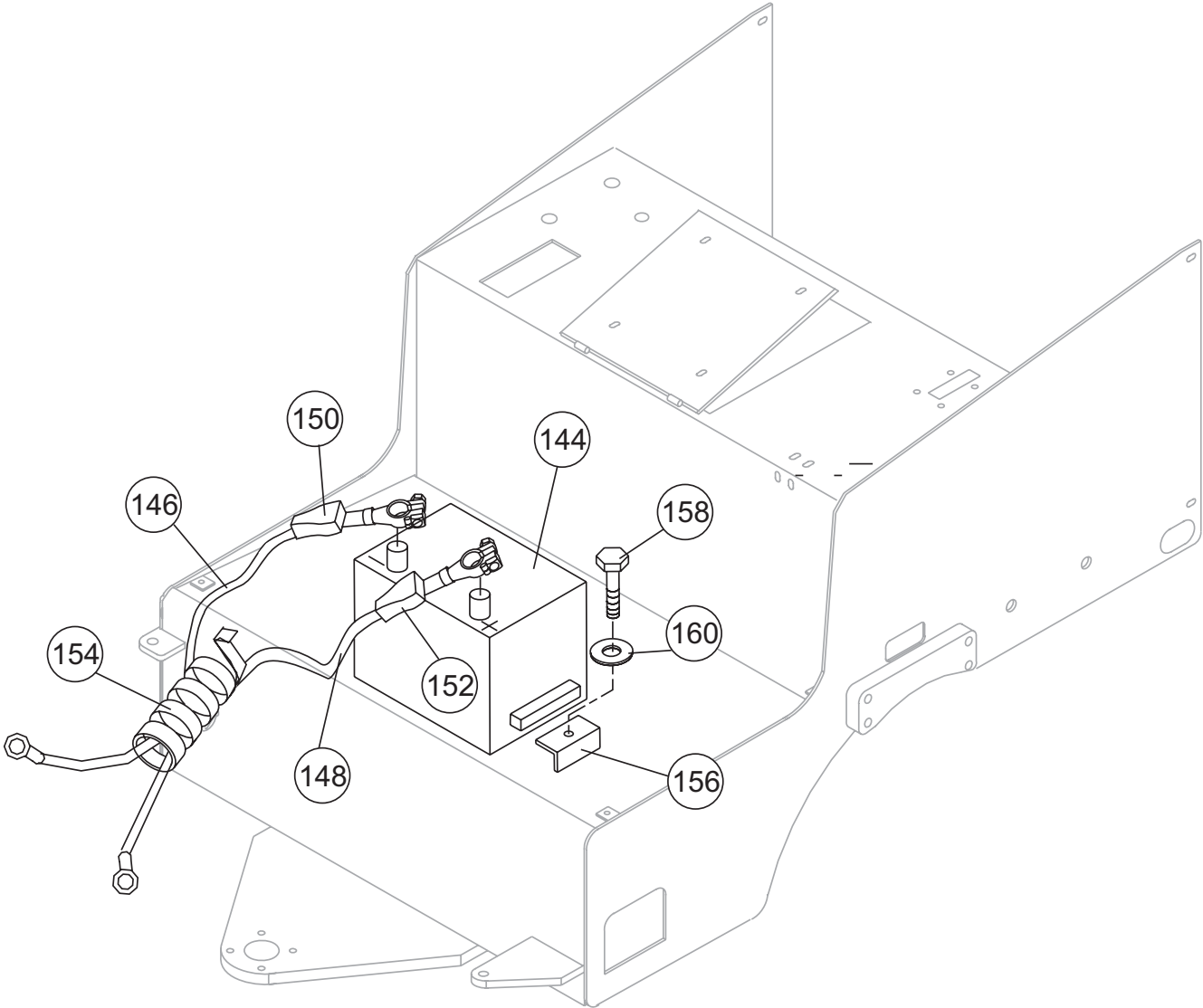

NOTES:
REMOVE ITEMS 20
AND 29 ON PAGE 58
FOR BATTERY ACCESS

AR-13HA RIDE-ON ROLLER — BATTERY ASSY.

BATTERY ASSY.

<u>NO.</u>	<u>PART NO.</u>	<u>PART NAME</u>	<u>QTY.</u>	<u>REMARKS</u>
144	507590	BATTERY 12V	1	
146	513446	CABLE (-) BATTERY	1	
148	513445	CABLE (+) BATTERY	1	
150	505624	BATTERY TERMINAL COVER	1	BLACK
152	506266	BATTERY TERMINAL COVER	1	RED
154	506152	WRAP	1	
156	506151	CLAMP, BATTERY	1	
158	TBD	HEX HEAD SCREW 3/8"X2" NC G5	1	
160	3019092	WASHER, FLAT 3/8"	1	REPLACES 492598

AR-13HA RIDE-ON ROLLER — SCRAPER ASSY.

SCRAPER ASSY.

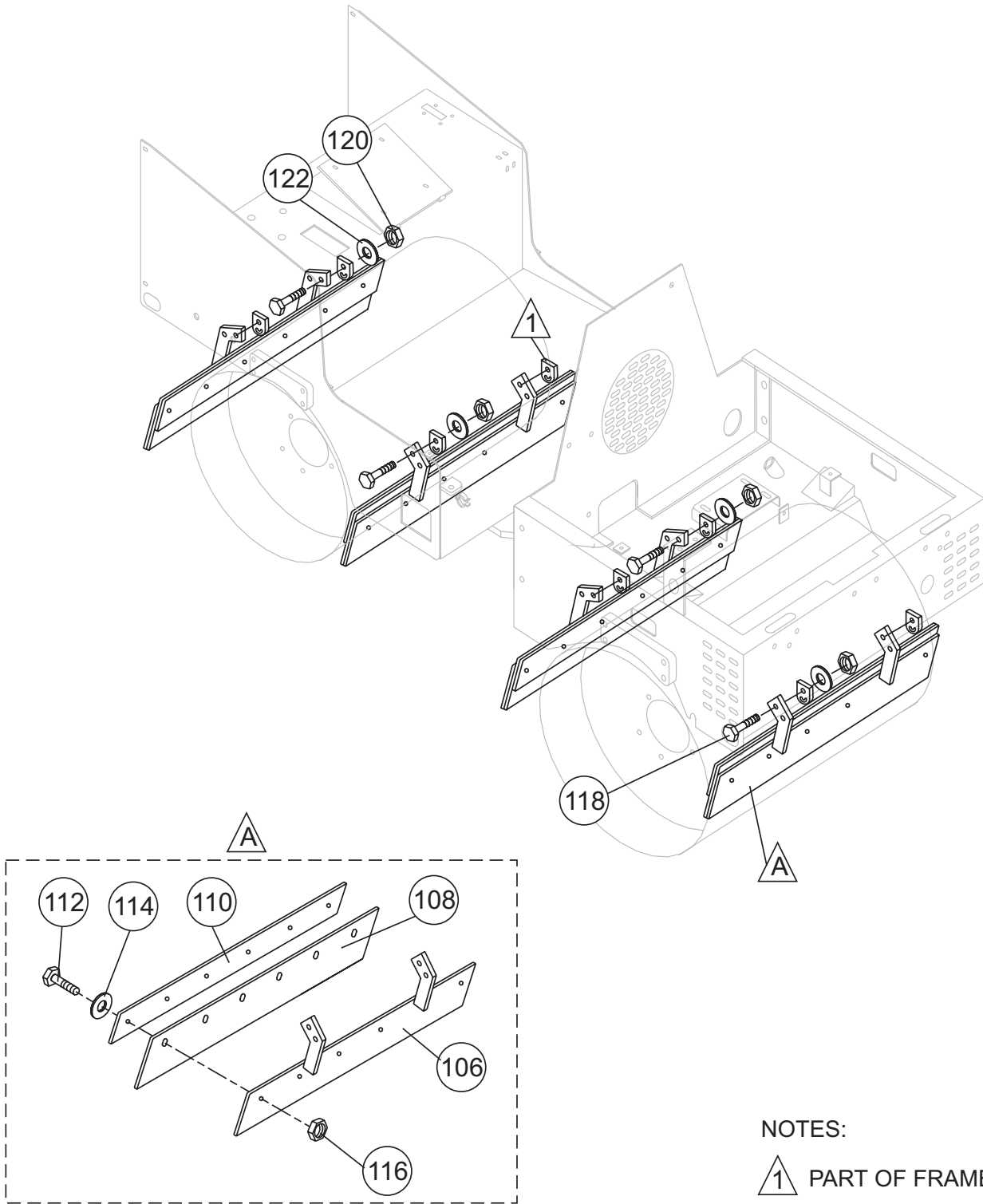

NOTES:

△ PART OF FRAME

AR-13HA RIDE-ON ROLLER — SCRAPER ASSY.

SCRAPER ASSY.

<u>NO.</u>	<u>PART NO.</u>	<u>PART NAME</u>	<u>QTY.</u>	<u>REMARKS</u>
106	513290	SCRAPER, SUPPORT	4	
108	508433	SCRAPER, RUBBER	4	
110	508434	PLATE BACKING	4	
112	EM963057	BOLT 3/8"	12	REPLACES 492313
114	3019092	WASHER, FLAT3/8"	12	REPLACES 492598
116	EM969013	NUT, LOCK 3/8"	12	REPLACES 492583
118	EM963692	BOLT, 1/2" UNC X 1-1/2"	8	REPLACES 492384
120	492584	NUT, LOCK 1/2" NC	8	
122	621	WASHER 1/2" SPECIAL	8	

HONDA GX610K1QZB2 ENGINE — AIR CLEANER ASSY.

AIR CLEANER ASSY.

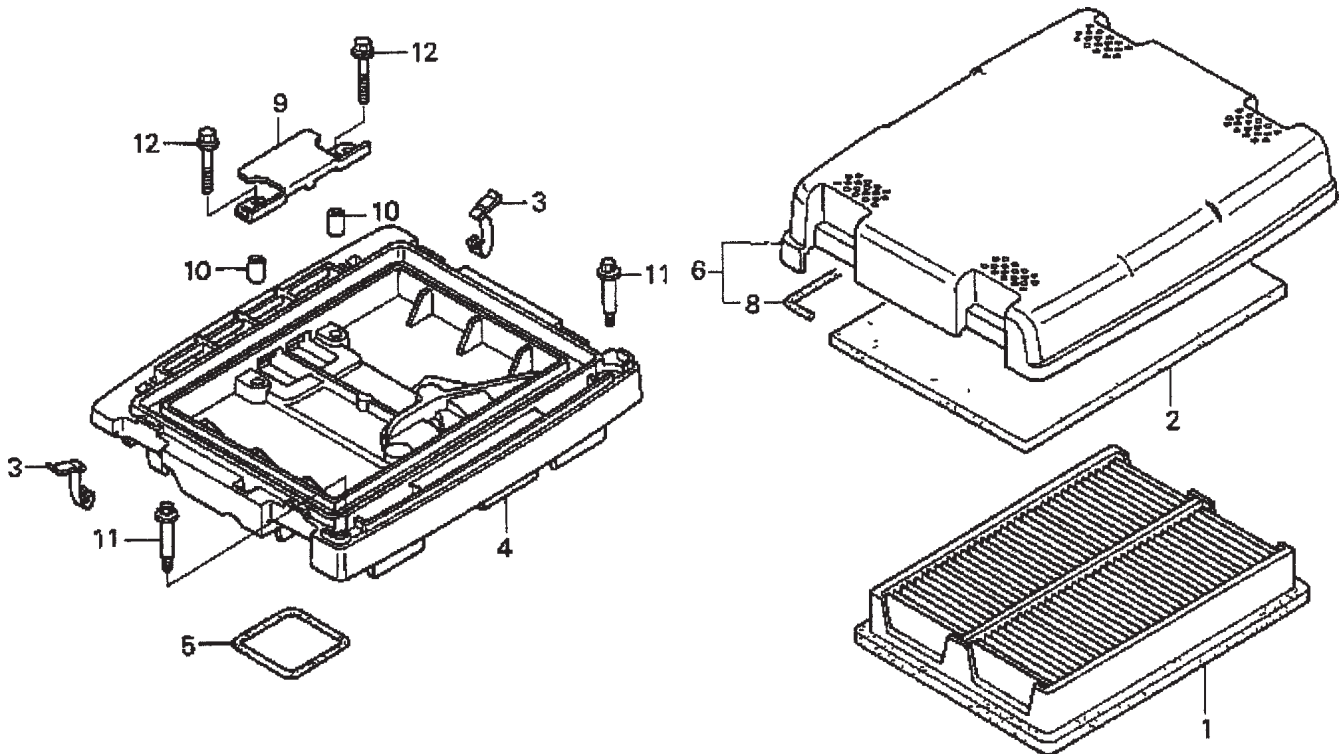

HONDA GX610K1QZB2 ENGINE — AIR CLEANER ASSY.

AIR CLEANER ASSY.

<u>NO.</u>	<u>PART NO.</u>	<u>PART NAME</u>	<u>QTY.</u>	<u>REMARKS</u>
1	17210ZJ1841	ELEMENT, AIR CLEANER	1	
2	17218ZJ1840	FILTER (OUTER)	1	
3	17219ZJ1840	CLIP, AIR CLEANER	4	
4	17220ZJ1840	HOUSING, AIR CLEANER	1	
5	17229ZJ1840	SEAL, AIR CLEANER HOUSING	1	
6	17230ZJ1840	COVER ASSEMBLY, AIR CLEANER.....	1	INCLUDES ITEM W/*
8 *	17233ZJ1840	SEAL, AIR CLEANER COVER	1	
9	17234ZJ1840	PLATE, AIR CLEANER SETTING	1	
10	17238ZJ4830	COLLAR A, AIR CLEANER	2	
11	90003ZJ1840	BOLT, SPECIAL 5MM	2	
12	957010602800	BOLT, FLANGE 6X28	2	

HONDA GX610K1QZB2 ENGINE — CARBURETOR ASSY.

CARBURETOR ASSY.

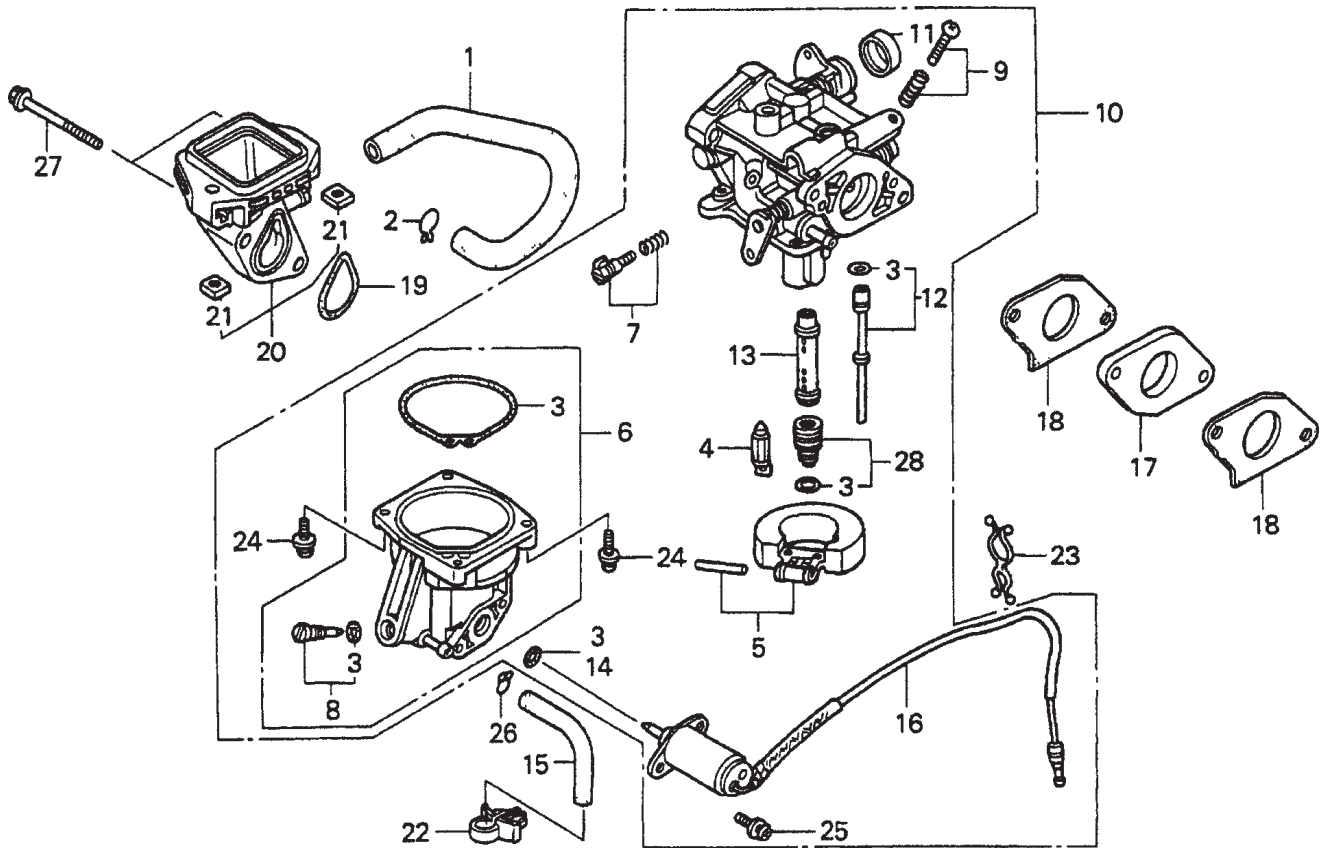

HONDA GX610K1QZB2 ENGINE — CARBURETOR ASSY.

CARBURETOR ASSY.

<u>NO.</u>	<u>PART NO.</u>	<u>PART NAME</u>	<u>QTY.</u>	<u>REMARKS</u>
1	12357ZJ1840	TUBE, BREATHER	1	
2	15772551000	CLIP, BREATHER TUBE	1	
3*#	16010ZG8000	GASKET SET	1	
4*	16011KCK910	VALVE SET, FLOAT	1	
5*	16013ZV4005	FLOAT SET	1	
6*	16015ZJ1841	CHAMBER SET, FLOAT	1	INCLUDES ITEMS W/#
7*	16016ZJ1010	SCREW SET	1	
8*#	16024124760	SCREW SET, DRAIN	1	
9*	16028ZG8000	SCREW SET	1	
10	16100ZJ10831	CARBURETOR ASSEMBLY, BG21H A	1	INCLUDES ITEMS W/*
11*	16148141881	CAP, CHOKE LEVER DUST	1	
12*	16150ZJ0831	JET SET #58	1	
13*	16166ZJ0831	NOZZLE, MAIN	1	
14*	16178548004	O- RING 5.8X1.9	1	
15	16198ZJ1840	TUBE, DRAIN	1	
16*	16200ZJ1841	VALVE ASSEMBLY, SOLENOID	1	
17	16211ZJ0841	INSULATOR, CARBURETOR	1	
18	16221ZJ1840	GASKET, CARBURETOR	2	
19	17228ZG8003	GASKET, AIR CLEANER	1	
20	17410ZJ1840	ELBOW, AIR CLEANER	1	
21	90314ZJ1840	NUT, INSERT 6MM	2	
22	90682959661	CLIP B, CABLE	1	
23	91402ZJ1841	CLIP, PURSE LOCK	1	
24*	938920401408	SCREW- WASHER 4X14	4	
25	938920501208	SCREW- WASHER 5X12	2	
26	9500202080	CLIP, TUBE B8	1	
27	958010612000	BOLT, FLANGE 6X120	2	
28*	99201ZG80880	JET SET, MAIN #88 (OPTIONAL)	1	
28	99201ZG80900	JET SET, MAIN #90 (OPTIONAL)	1	
28	99201ZG80920	JET SET, MAIN #92 (OPTIONAL)	1	

HONDA GX610K1QZB2 ENGINE — CONTROL ASSY.

CONTROL ASSY.

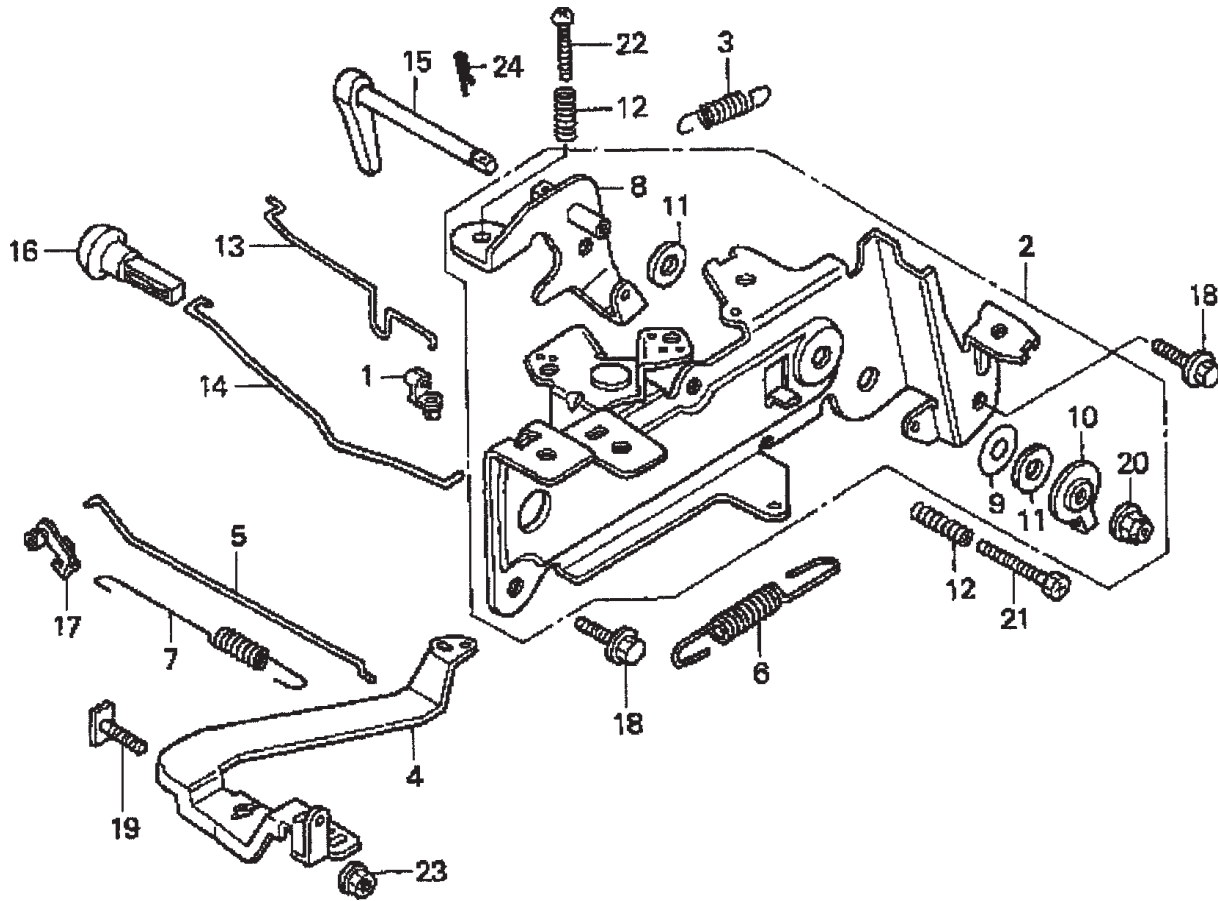

HONDA GX610K1QZB2 ENGINE — CONTROL ASSY.

CONTROL ASSY.

<u>NO.</u>	<u>PART NO.</u>	<u>PART NAME</u>	<u>QTY.</u>	<u>REMARKS</u>
1	16263883W10	JOINT, ROD	1	
2	16500ZJ1850	CONTROL ASSEMBLY	1	INCLUDES ITEMS W/*
3	16534ZJ1840	SPRING, STARTER	1	
4	16551ZJ1840	ARM, GOVERNOR	1	
5	16555ZJ1840	ROD, GOVERNOR	1	
6	16561ZJ1850	SPRING, GOVERNOR (MANUAL)	1	
7	16562ZJ1840	SPRING, THROTTLE RETURN	1	
8*	16570ZJ1850	ARM, CONTROL	1	
9*	16574883300	SPRING, LEVER	1	
10*	16575ZJ1850	WASHER, CONTROL ARM	1	
11*	16576883300	SPACER, CONTROL LEVER	2	
12	16584883300	SPRING, CONTROL ADJUSTING	2	
13	16611ZJ1840	ROD, CHOKE CONTROL	1	
14	16628ZJ1850	ROD, CHOKE KNOB	1	
15	17850ZJ1850	LEVER ASSEMBLY, THROTTLE	1	
16	17951921030	KNOB, CHOKE	1	
17	17957ZV4000	BUSH, LINKAGE	1	
18	90014952000	BOLT, FLANGE 6X14	2	
19	90015ZE3790	BOLT, GOVERNOR ARM	1	
20*	90114SA0000	NUT, SELF- LOCK 6MM	1	
21	92301050250A	BOLT, SLOT 5X25	1	
22	93500050250A	SCREW, PAN 5X25	1	
23	9405006000	NUT FLANGE 6 MM	1	
24	9425110000	PIN, LOCK 10 MM	1	

HONDA GX610K1QZB2 ENGINE — CRANKCASE COVER ASSY.

CRANKCASE COVER ASSY.

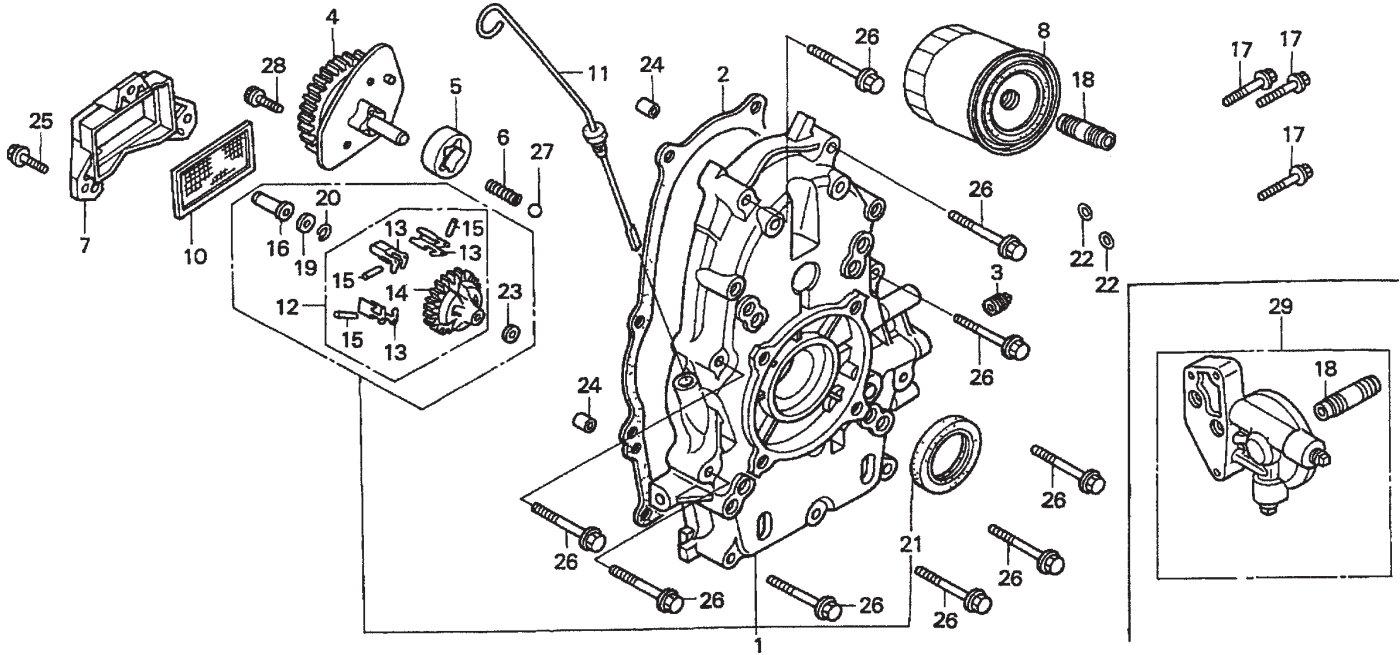

HONDA GX610K1QZB2 ENGINE — CRANKCASE COVER ASSY.

CRANKCASE COVER ASSY.

NO.	PART NO.	PART NAME	QTY.	REMARKS
1	11300ZJ1840	COVER ASSY., CRANKCASE Q TYPE	1	INCLUDES ITEMS/*
2	11381ZJ1840	GASKET, CASE COVER	1	
3	12105ZA0701	BOLT, SEALING	1	
4	15120ZJ1000	COVER ASSEMBLY, OIL PUMP	1	
5	15124ZJ1003	ROTOR, OIL PUMP (OUTER)	1	
6	15232ZJ1000	SPRING, RELIEF VALVE	1	
7	15348ZJ1840	COVER, OIL FILTER	1	
8	15410ZJ4999AH	FILTER, OIL	1	SOLD INDIVIDUALLY
10	15427ZJ1000	SCREEN, OIL FILTER	1	
11	15655ZJ1840	DIPSTICK, OIL	1	
12*	16510ZJ1840	GOVERNOR ASSEMBLY	1	INCLUDES ITEMS/%
13*%	16511ZJ1840	WEIGHT, GOVERNOR	3	
14*%	16512ZJ1840	HOLDER, GOVERNOR WEIGHT	1	
15*%	16513ZE2000	PIN, GOVERNOR WEIGHT	3	
16*	16531ZE2000	SLIDER, GOVERNOR	1	
17	90014ZE6000	BOLT, FLANGE 6X35	3	
18#	90018PN3000	HOLDER, OIL FILTER	1	
19*	90473147000	WASHER 6X16	1	
20*	90602ZE1000	CLIP, GOVERNOR HOLDER	1	
21*	91202ZJ1841	OIL SEAL 38X58X9	1	
22	91320MJ6003	O- RING 11.8X2.4	2	
23*	9410106800	WASHER, PLAIN 6MM	1	
24	9430108140	PIN A, DOWEL 8X14	2	
25	957010602000	BOLT, FLANGE 6X20	3	
26	957010805000	BOLT, FLANGE 8X50	9	
27	9621112000	BALL, STEEL #12 (3/8)	1	
28	966000601600	BOLT, SOCKET 6X16	2	
29	15410ZJ1800	BASE, OIL FILTER A	1	INCLUDES ITEMS/#

HONDA GX610K1QZB2 ENGINE — CAMSHAFT ASSY.

CAMSHAFT ASSY.

<u>NO.</u>	<u>PART NO.</u>	<u>PART NAME</u>	<u>QTY.</u>	<u>REMARKS</u>
1	12209ZE8003	SEAL, VALVE STEM	2	
2	14100ZJ1842	CAMSHAFT ASSEMBLY	1	
3	14410ZJ1840	ROD, PUSH	4	
4	14431ZE2010	ARM, VALVE ROCKER	4	
5	14451ZE1013	PIVOT, ROCKER ARM	4	
6	14568ZJ1841	SPRING, WEIGHT RETURN	1	
7	14576ZJ1840	PIN, DECOMPRESSION	1	
8	14711ZE3000	VALVE, INTAKE	2	
9	14721ZE3000	VALVE, EXHAUST	2	
10	14730ZJ1840	LIFTER ASSEMBLY, VALVE	1	INCLUDES ITEMS W/*
11	14751ZE2003	SPRING, VALVE	4	
12*	14760ZJ1840	SHAFT, VALVE LIFTER	1	
13*	14764ZJ1840	SPRING VALVE LIFTER	2	
14	14771ZE2000	RETAINER, INTAKE VALVE SPRING	2	
15	14773ZE2000	RETAINER, EXHAUST VALVE SPRING	2	
16	14775ZE2010	SEAT, VALVE SPRING	2	
17	14781ZE2000	ROTATOR, VALVE	2	
18	14791ZE2010	PLATE, PUSH ROD GUIDE	2	
19	90005896000	BOLT, FLANGE 5X16	1	
20	90012ZE0010	BOLT, PIVOT 8MM	4	
21	90206ZE1000	NUT, PIVOT ADJ.	4	
22	90446357000	WASHER, THRUST 17.2MM	1	
23*	90602ZE1000	CLIP, GOVERNOR HOLDER	2	
24	9430108120	PIN A, DOWEL 8X12	1	
25*	9410106800	WASHER, PLAIN 6MM	4	
26	9430560282	PIN, SPRING 6X28	1	
27	957010602500	BOLT, FLANGE 6X25	1	

HONDA GX610K1QZB2 ENGINE — CRANKSHAFT ASSY.

CRANKSHAFT ASSY.

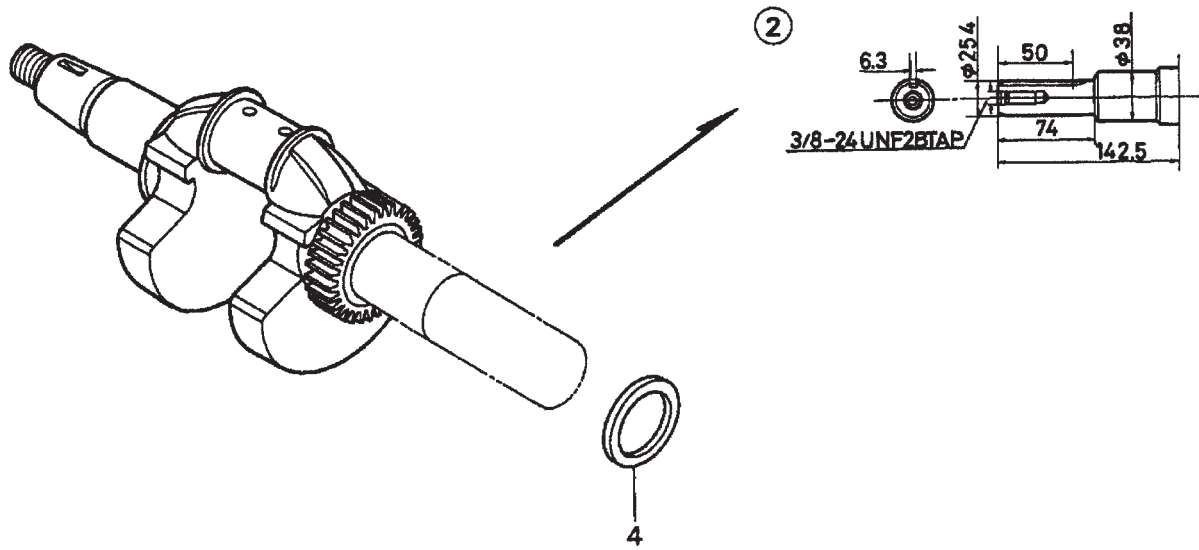

HONDA GX610K1QZB2 ENGINE — CRANKSHAFT ASSY.

CRANKSHAFT ASSY.

<u>NO.</u>	<u>PART NO.</u>	<u>PART NAME</u>	<u>QTY.</u>	<u>REMARKS</u>
2	13310ZJ1840	CRANKSHAFT	1	
4	90401ZJ1000	WASHER, CRANKSHAFT THRUST	1	

HONDA GX610K1QZB2 ENGINE — CYLINDER BARREL ASSY.

CYLINDER BARREL ASSY.

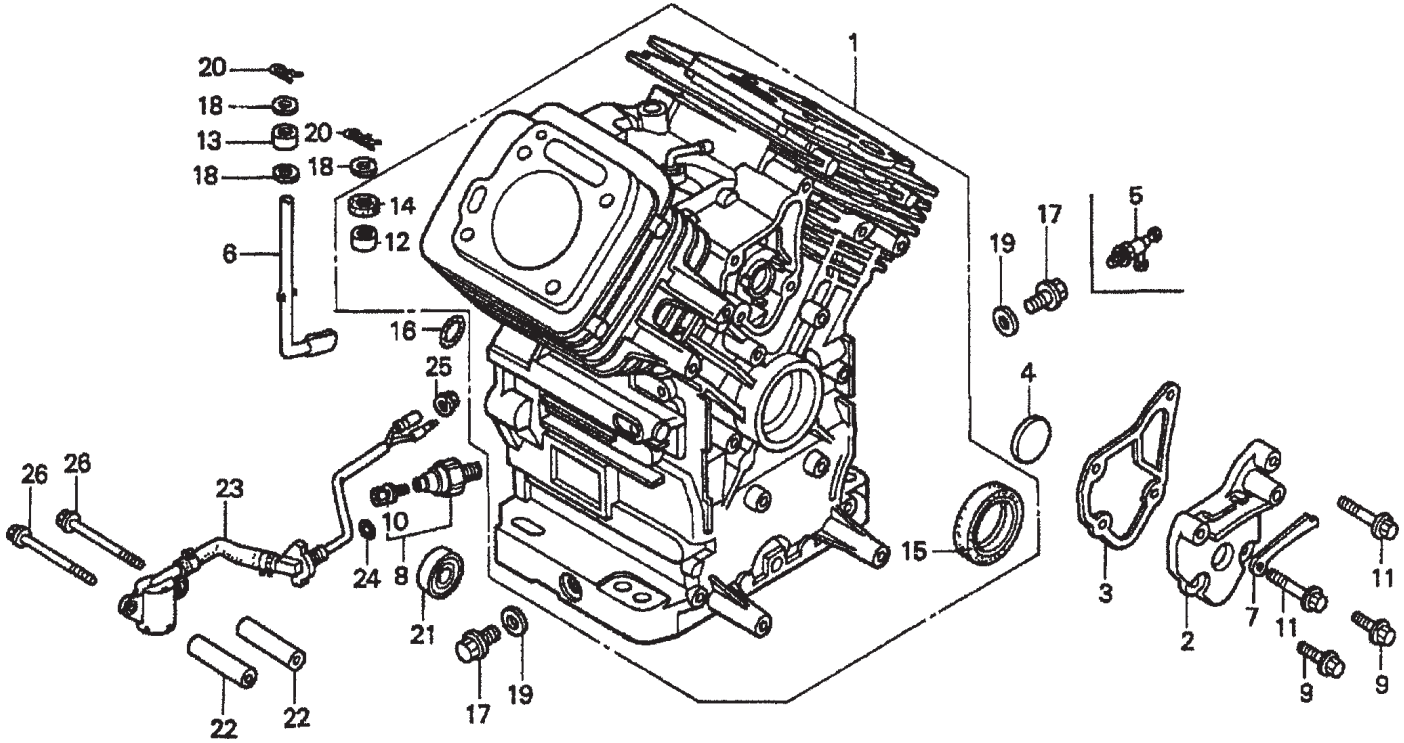

HONDA GX610K1QZB2 ENGINE — CYLINDER BARREL ASSY.

CYLINDER BARREL ASSY.

<u>NO.</u>	<u>PART NO.</u>	<u>PART NAME</u>	<u>QTY.</u>	<u>REMARKS</u>
1	12000ZJ1850	CYLINDER ASSEMBLY, (OIL ALERT)	1	INCLUDES ITEMS W/*
2	12356ZJ1000	COVER, BREATHER COVER	1	
3	12358ZJ1000	GASKET, BREATHER COVER	1	
4	12371ZE2300	VALVE, BREATHER	1	
5	15558ZJ1010AH	VALVE, DRAIN 14X1.5 (OPTIONAL)	1	
6	16541ZJ1840	SHAFT, GOVERNOR ARM	1	
7	31511ZJ1000	CLAMP, WIRE	1	
9	90029888000	BOLT, FLANGE 6X16	2	
11	90031ZE1000	BOLT, FLANGE 6X32	2	
12*	91001ZJ1841	BEARING, NEEDLE 8X12.7X11.1	1	
13	91002ZJ1841	BEARING, NEEDLE 8X12X10	1	
14*	91201ZE9003	OIL SEAL 8X14X5	1	
15*	91201ZJ1841	OILSEAL 38X58X9	1	
16	91302MB6830	O- RING 13X3.0	1	
17	9280014000	BOLT, DRAIN PLUG 14MM	2	
18	9410208800	WASHER, PLAIN 6MM	3	
19	9410914000	WASHER, DRAIN PLUG 14MM	2	
20	9425108000	PIN, LOCK 8MM	2	
21	961406003010	BEARING, RADIAL BALL 6003	1	
22	25523VD6010	COLLAR, FILTER SETTING	2	
23	35480ZJ1841	SWITCH ASSEMBLY, OIL LEVEL	1	
24	91353671003	O- RING 13.5X1.5 (ARAI)	1	
25	9405010000	NUT, FLANGE 10MM	1	
26	957010607509	BOLT,FLANGE 6X75	2	

HONDA GX610K1QZB2 ENGINE — CYLINDER HEAD ASSY.

CYLINDER HEAD ASSY.

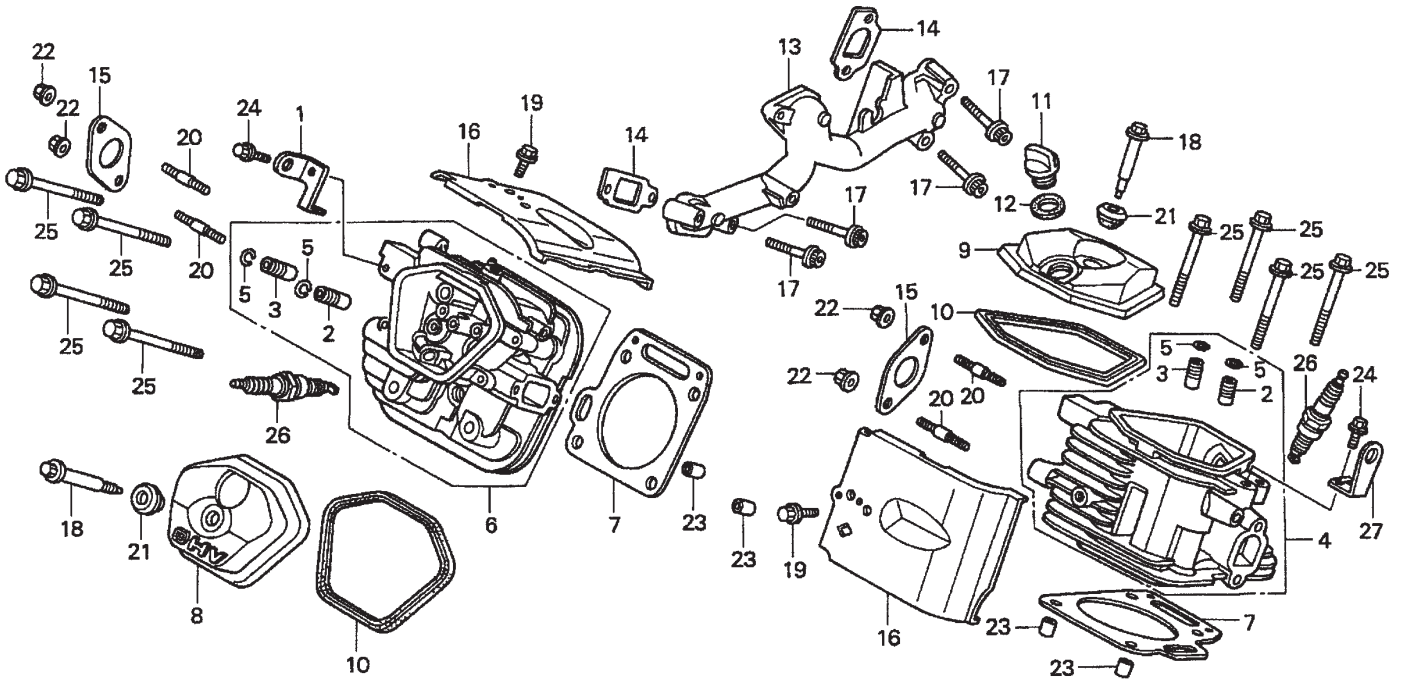

HONDA GX610K1QZB2 ENGINE — CYLINDER HEAD ASSY.

CYLINDER HEAD ASSY.

<u>NO.</u>	<u>PART NO.</u>	<u>PART NAME</u>	<u>QTY.</u>	<u>REMARKS</u>
1	11911ZJ1840	HANGER,ENGINE	1	
2*#	12204ZE2306	GUIDE, VALVE OS (OPTIONAL)	2	
3*#	12205ZJ1405	GUIDE, EX. VALVE OS (OPTIONAL)	2	
4	12210ZJ1840	CYLINDER HEAD #1	1	INCLUDES ITEMS W/#
5*#	12216ZE2300	CLIP, VALVEGUIDE	4	
6	12220ZJ1840	CYLINDER HEAD #2	1	INCLUDES ITEMS W/*
7	12251ZJ1841	GASKET, CYLINDER HEAD	2	
8	12311ZJ1840	COVER, HEAD	1	
9	12314ZJ1840	COVER, HEAD FILLER	1	
10	12391ZE2020	GASKET, CYLINDER HEAD COVER	2	
11	15611MB0000	CAP, OIL FILLER	1	
12	15625ZJ1840	GASKET, OIL FILLER CAP	1	
13	17101ZJ1840	MANIFOLD, INTAKE	1	
14	17151ZJ1841	GASKET, INTAKE MANIFOLD	2	
15	18333ZE3800	GASKET, EXHAUST PIPE	2	
16	19682ZJ1840	SHROUD, HEAD	2	
17	90011ZJ1841	BOLT, SOCKET 8X45	4	
18	90014ZE2000	BOLT, HEAD COVER	2	
19	90014952000	BOLT, FLANGE 6X14	2	
20	90018ZJ1840	BOLT, STUD 8X22	4	
21	90441ZE2010	WASHER, HEAD COVER	2	
22	9405008000	NUT, FLANGE 8MM	4	
23	9430112200	PIN A, DOWEL 12X20	4	
24	957010802000	BOLT, FLANGE 8X20	2	
25	957011008000	BOLT, FLANGE 10X80	8	
26	9807952876	SPARK PLUG BPR2ES (NGK)	2	
27	11911ZJ1840	HANGER, ENGINE	1	

HONDA GX610K1QZB2 ENGINE — FAN COVER ASSY.

FAN COVER ASSY.

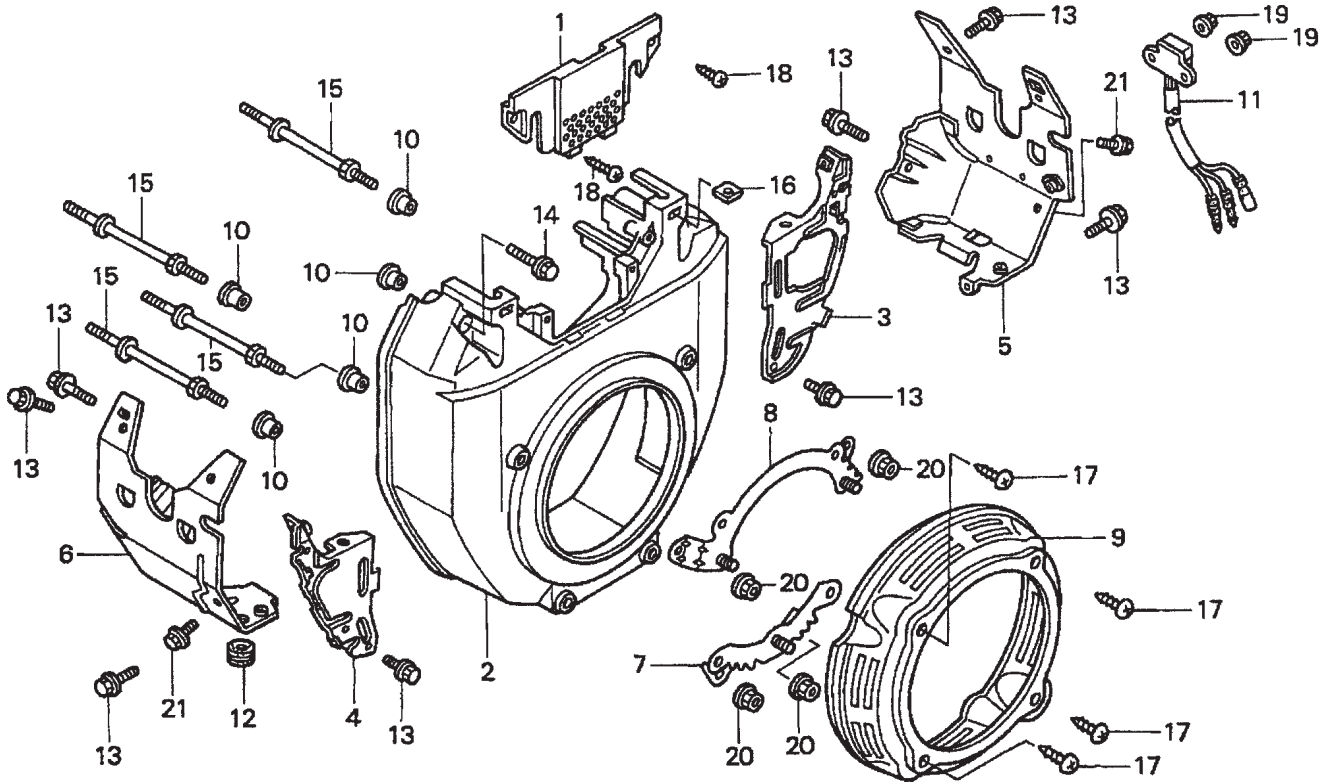

HONDA GX610K1QZB2 ENGINE — FAN COVER ASSY.

FAN COVER ASSY.

<u>NO.</u>	<u>PART NO.</u>	<u>PART NAME</u>	<u>QTY.</u>	<u>REMARKS</u>
1	16715ZJ1850	COVER, FUEL PUMP	1	
2	19611ZJ1850ZB	COVER, FAN *R8* RECOIL STARTER RED	1	
3	19612ZJ1840	PLATE, RIGHT SIDE	1	
4	19614ZJ1840	PLATE, LEFT SIDE	1	
5	19631ZJ1850	SHROUD, RIGHT (OIL ALERT)	1	
6	19632ZJ1840	SHROUD, LEFT	1	
7	28491ZJ1840	STAY A, RECOIL STARTER	1	
8	28492ZJ1840	STAY B, RECOIL STARTER	1	
9	28496ZJ1840ZB	COVER, RECOIL STARTER STAY *R8* RED	1	
10	33713GC2000	COLLAR B, TAILLIGHT	6	
11	34150ZJ1841	ALERT UNIT ASSEMBLY, OIL	1	
12	80101310000	RUBBER, RR. FENDER CUSION	1	
13	90013883000	BOLT, FLANGE 6X12 (CT200)	10	
14	90018ZE1000	BOLT, FLANGE 6X23	2	
15	90042ZJ1840	BOLT, STUD 6X71	4	
16	90313ZJ1840	NUT, SQUARE 5MM	2	
17	9390335380	SCREW, TAPPING 5X16	4	
18	9391325580	SCREW, TAPPING 5X20	2	
19	9405005000	NUT, FLANGE 5MM	2	
20	9405006070	NUT, FLANGE 6MM	4	
21	957010600800	BOLT, FLANGE 6X8	2	

HONDA GX610K1QZB2 ENGINE — FUEL PUMP ASSY.

FUEL PUMP ASSY.

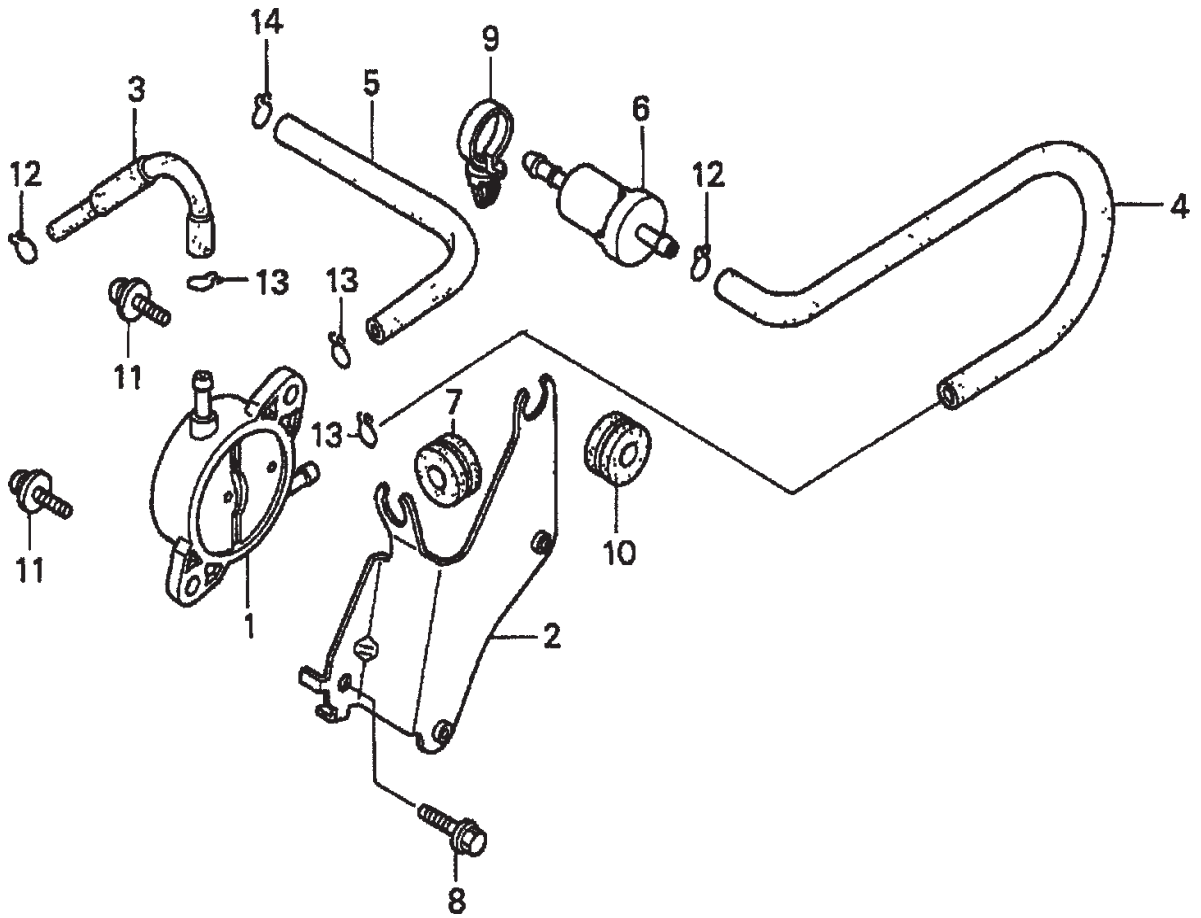

HONDA GX610K1QZB2 ENGINE — FUEL PUMP ASSY.

FUEL PUMP ASSY.

<u>NO.</u>	<u>PART NO.</u>	<u>PART NAME</u>	<u>QTY.</u>	<u>REMARKS</u>
1	16700ZL8003	PUMP ASSEMBLY, FUEL	1	
2	16711ZJ1840	STAY, FUEL PUMP	1	
3	16850ZJ1840	TUBE A, FUEL	1	
4	16852ZJ1840	TUBE B, FUEL	1	
5	16882ZJ1840	TUBE, DIAPHRAGM	1	
6	16910ZE8015	FILTER, FUEL	1	
7	19111MF5000	GROMMET, RESERVE TANK	1	
8	90014952000	BOLT, FLANGE 6X14	1	
9	90617SA0003	CLIP, WIRE HARNESS	1	
10	91601ZJ1840	GROMMET, PUMP STAY	1	
11	938940601600	SCREW- WASHER 6X16	2	
12	9500202080	CLIP, TUBE B8	2	
13	9500202100	CLIP, TUBE B10	3	
14	9500250000	CLIP, TUBE C9	1	

HONDA GX610K1QZB2 ENGINE — FLYWHEEL ASSY.

FLYWHEEL ASSY.

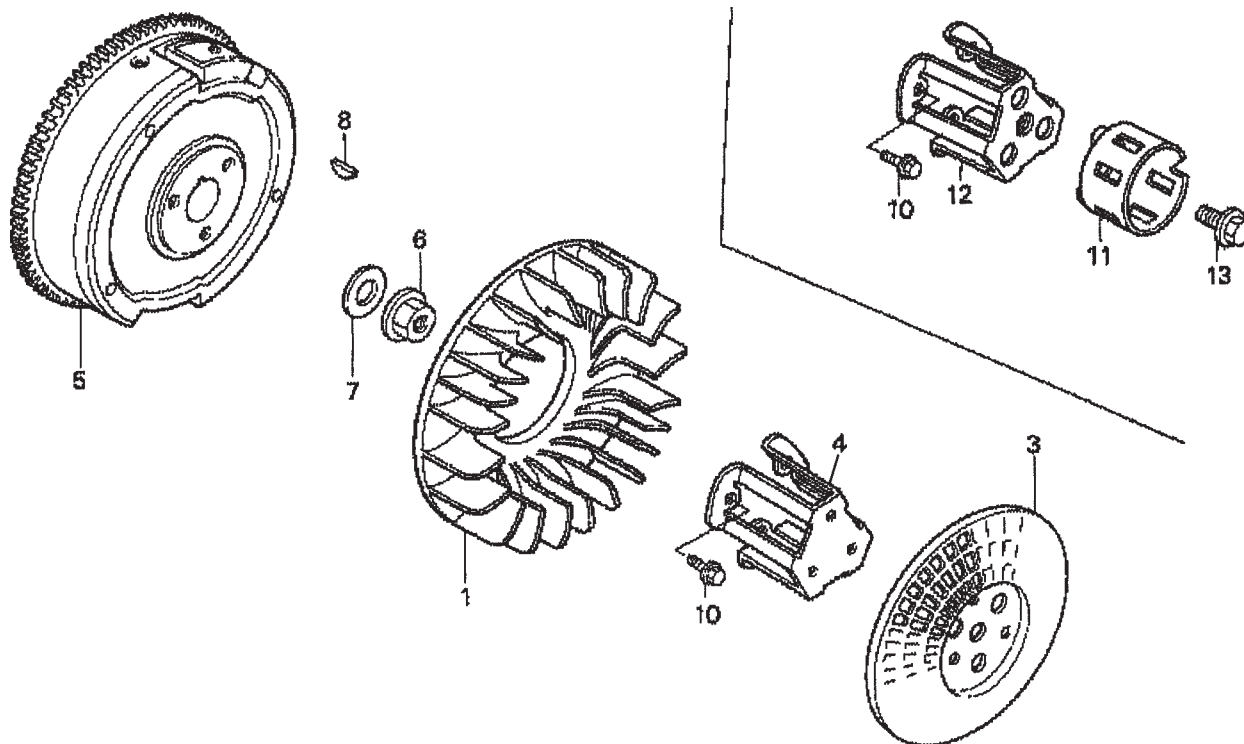

HONDA GX610K1QZB2 ENGINE — FLYWHEEL ASSY.

FLYWHEEL ASSY.

<u>NO.</u>	<u>PART NO.</u>	<u>PART NAME</u>	<u>QTY.</u>	<u>REMARKS</u>
1	19511ZJ1000	FAN, COOLING	1	
3	28452ZJ1811	GRID, SCREEN P. T. O. (OPTIONAL)	1	
4	28454ZJ1801	HOLDER, SCREEN GRID (OPTIONAL)	1	
5	31110ZJ1840	FLYWHEEL	1	
6	90201ZG3000	NUT, FLANGE 20MM	1	
7	90401ZG3000	WASHER 20MM	1	
8	90741ZE2000	KEY, SPECIAL WOODRUFF 25X18	1	
10	957010801600	BOLT, FLANGE 8X16	3	
11	28451ZJ1801	PULLEY, STARTER	1	
12	28453ZJ1801	SPACER, STARTER PULLEY MOUNTING	1	
13	90013ZJ1800	BOLT, UBS 12X28	1	

HONDA GX610K1QZB2 ENGINE — IGNITION ASSY.

IGNITION COIL ASSY.

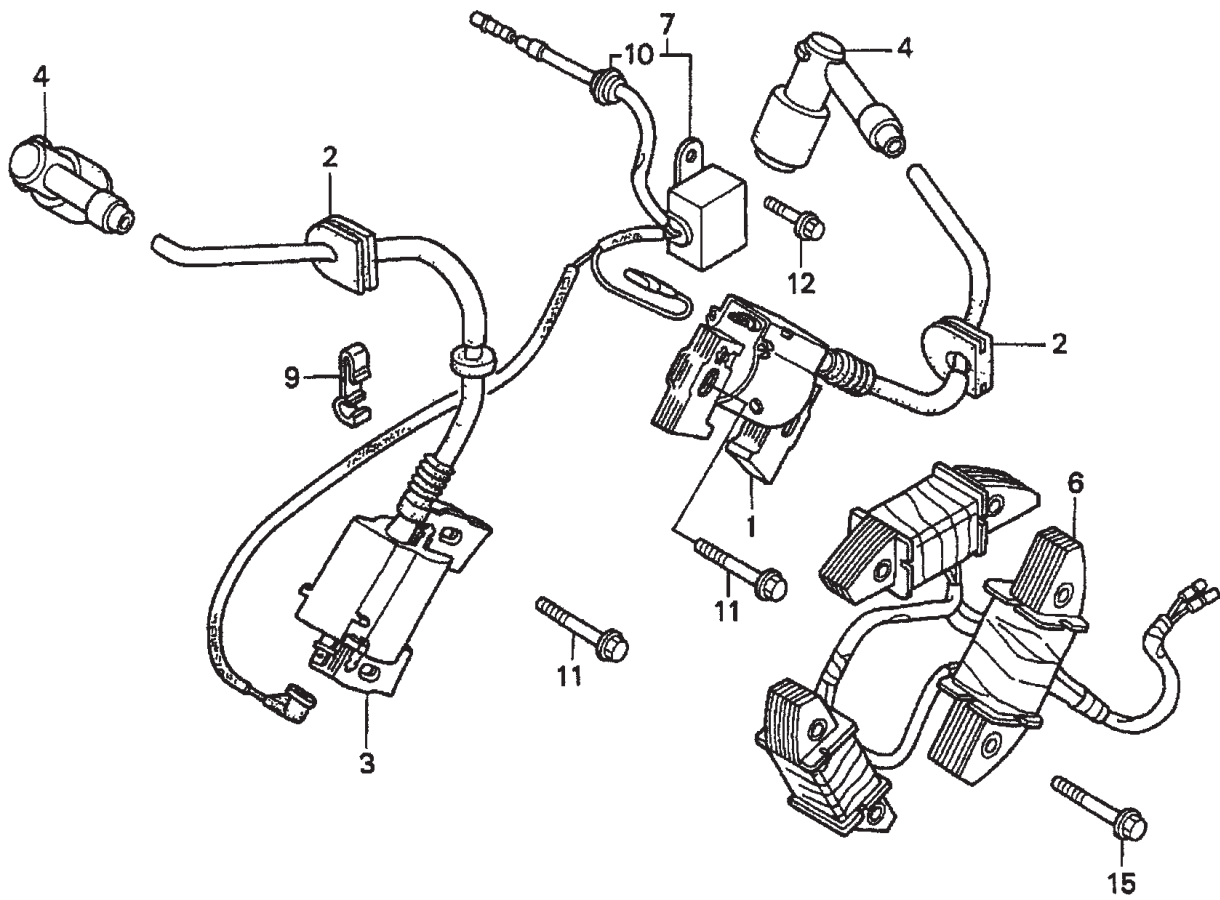

HONDA GX610K1QZB2 ENGINE — IGNITION ASSY.

IGNITION COIL ASSY.

<u>NO.</u>	<u>PART NO.</u>	<u>PART NAME</u>	<u>QTY.</u>	<u>REMARKS</u>
1	30500ZJ1841	COIL ASSEMBLY, RIGHT IGNITION	1	
2	30518ZJ1000	GROMMET, IGNITION WIRE	2	
3	30550ZJ1841	COIL ASSEMBLY, LEFT IGNITION	1	
4	30700ZJ1841	CAP ASSEMBLY, NOISE SUPPRESSOR	2	
6	31630ZJ1801	COIL ASSEMBLY, CHARGE 12V/20A	1	
7	31740ZJ1861	DIODE ASSEMBLY, ENGINE STOP	1	INCLUDES ITEMS W/*
9	32763PA0000	CLAMP, WIRE	1	
10*	63312ZA7000	GROMMET, TOOL	1	
11	90031ZE1000	BOLT, FLANGE 6X32	2	
12	957010600800	BOLT, FLANGE 6X8	1	
15	90031ZE1000	BOLT, FLANGE 6X32	6	

HONDA GX610K1QZB2 ENGINE — PISTON ASSY.

PISTON ASSY.

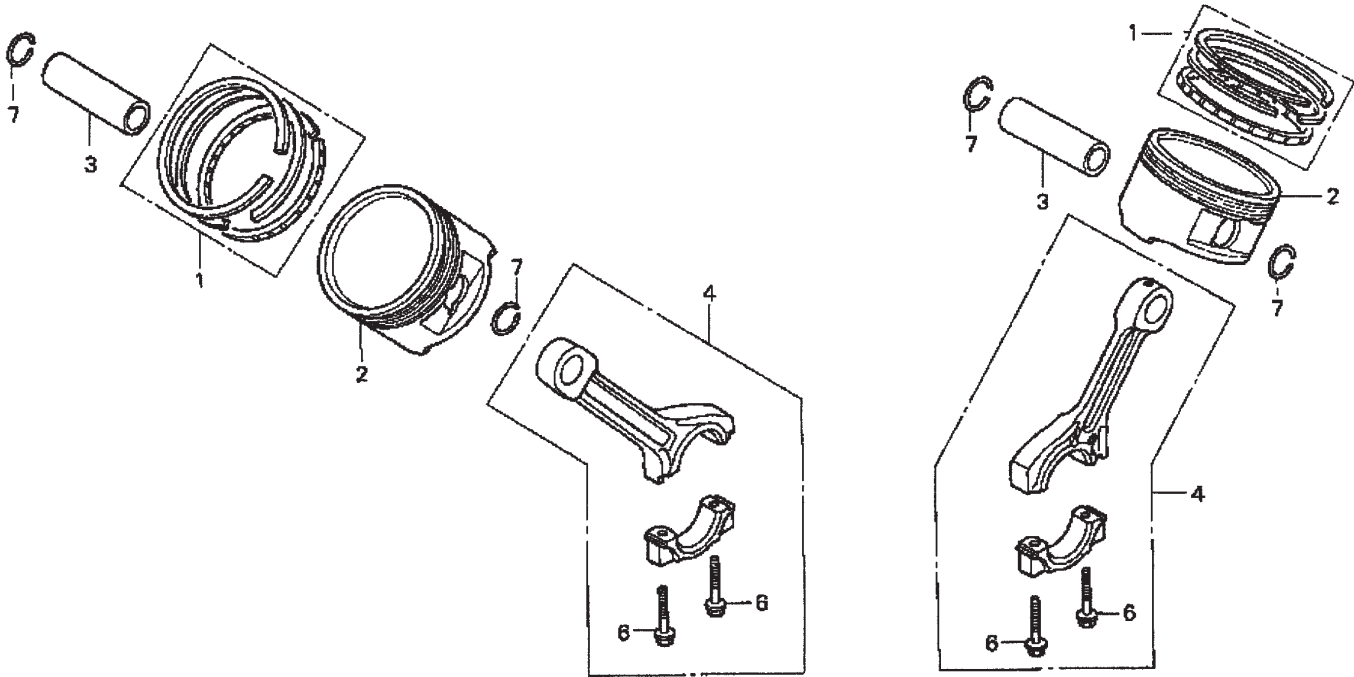

HONDA GX610K1QZB2 ENGINE — PISTON ASSY.

PISTON ASSY.

<u>NO.</u>	<u>PART NO.</u>	<u>PART NAME</u>	<u>QTY.</u>	<u>REMARKS</u>
1	13010ZJ1841	RING SET, PISTON (STANDARD)	2	
1	13011ZJ1841	RING SET, PISTON (OS 0.25)	2	
1	13012ZJ1841	RING SET, PISTON (OS 0.50)	2	
1	13013ZJ1841	RING SET, PISTON (0.75)	2	
2	13101ZJ1840	PISTON (STANDARD)	2	
2	13102ZJ1840	PISTON (OS 0.25)	2	
2	13103ZJ1840	PISTON (OS 0.50)	2	
2	13104ZJ1840	PISTON (0.75)	2	
3	13111ZJ1840	PIN, PISTON	2	
4	13200ZJ1841	ROD ASSEMBLY, CONNECTING	2	INCLUDES ITEMS W/*
6*	90001ZN1000	BOLT, CONNECTING ROD 6X37	4	
7	9460118000	CLIP, PISTON PIN 18MM	4	

HONDA GX610K1QZB2 ENGINE — STARTER MOTOR ASSY.

STARTER MOTOR ASSY.

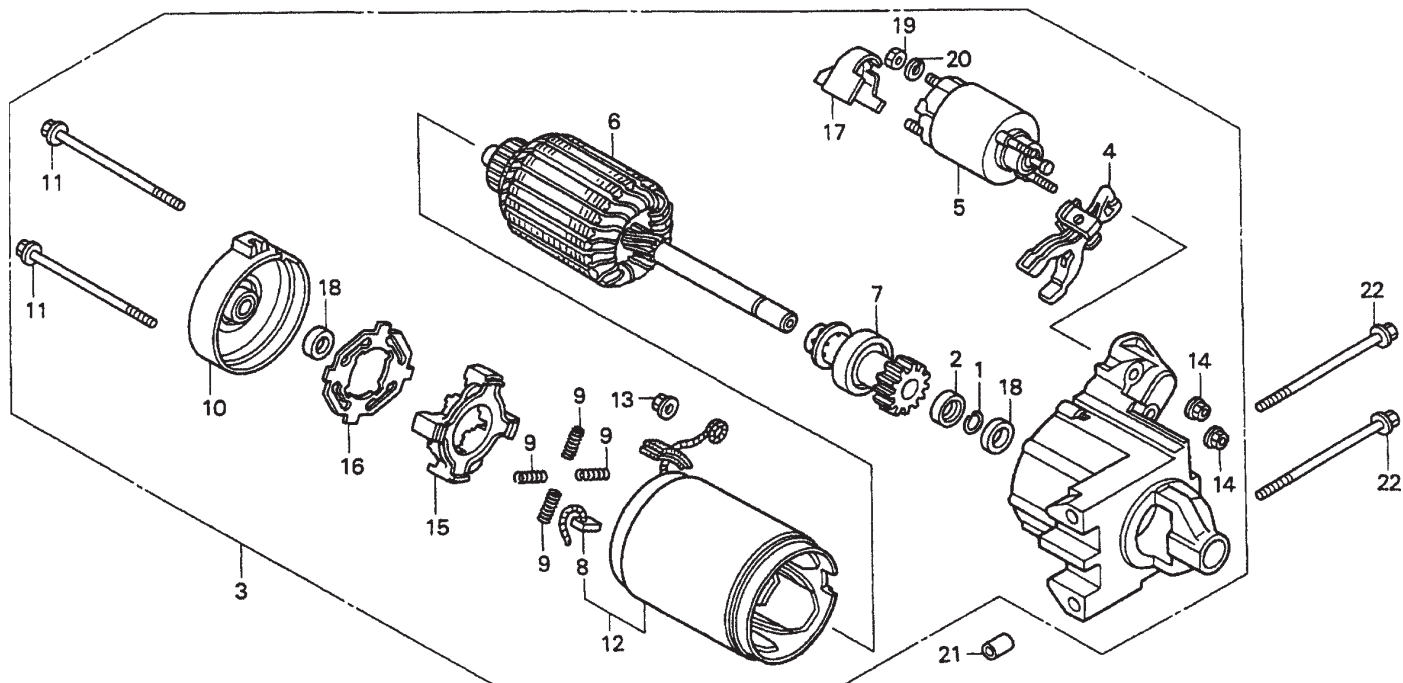

HONDA GX610K1QZB2 ENGINE — STARTER MOTOR ASSY.

STARTER MOTOR ASSY.

<u>NO.</u>	<u>PART NO.</u>	<u>PART NAME</u>	<u>QTY.</u>	<u>REMARKS</u>
1*	30201PH9004	RING, SNAP (DENSO)	1	
2*	30202PZ1003	COLLAR SET, CLUTCH STOP	1	
3	31200ZJ1841	MOTOR ASSEMBLY, STARTER	1	INCLUDES ITEMS W/*
4*	31203PH9004	LEVER, PINION DRIVE	1	
5*	31204ZJ1H01	SWITCH ASSEMBLY, MAGNET	1	
6*	31206ZG4801	ARMATURE	1	
7*	31207ZJ1H01	CLUTCH, OVERRUNNING	1	
8*	31211PH9004	BRUSH	4	
9*	31212PH9004	SPRING, BRUSH	4	
10*	31213P64N01	COVER	1	
11*	31214PH9004	BOLT, THROUGH	2	
12*	31216ZJ1H01	YOKE	1	
13*	31220PH9004	NUT, HEX. 8MM	1	
14*	31223PA0006	NUT, FLANGE 5MM	2	
15*	31231PH9004	HOLDER, BRUSH	1	
16*	31233PH9004	INSULATOR, BRUSH HOLDER	1	
17*	31234ZJ1H01	COVER, TERMINAL	1	
18*	91002ZG4801	BEARING A	2	
19*	94001080000S	NUT, HEX. 8MM	1	
20*	9411108000	WASHER, SPRING 8MM	1	
21	9430110120	PIN, DOWEL 10X12	2	
22	957010811000	BOLT, FLANGE 8X110	2	

HONDA GX610K1QZB2 ENGINE — LABELS ASSY.

LABELS ASSY.

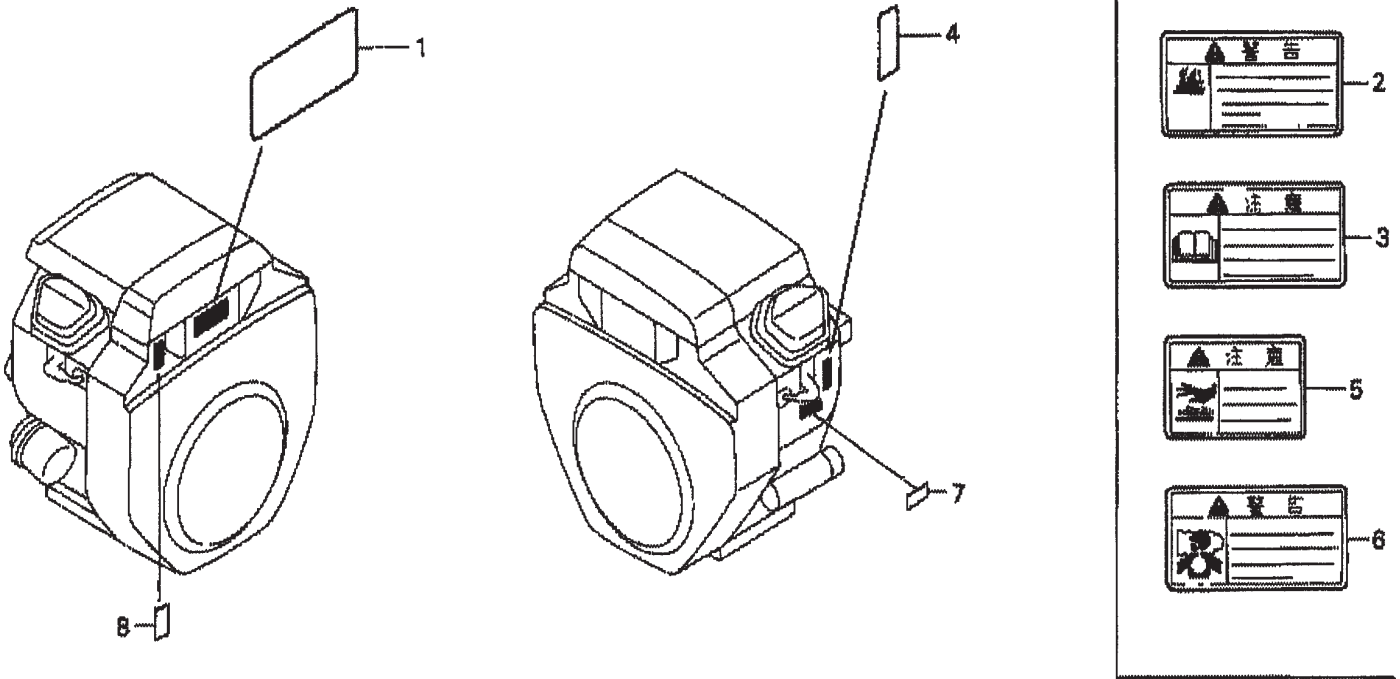

HONDA GX610K1QZB2 ENGINE — LABELS ASSY.

LABELS ASSY.

<u>NO.</u>	<u>PART NO.</u>	<u>PART NAME</u>	<u>QTY.</u>	<u>REMARKS</u>
1	87101ZJ0830	MARK, EMBLEM	1	
2	87106737J00	MARK, FUEL WARNING	1	
3	87150ZH8000	MARK, CAUTION J	1	
4	87152ZJ0000	LABEL, SPECIFICATION GX610	1	
5	87539737J00	MARK, HEAT CAUTION	1	
6	87561733J00	MARK, EXHAUST GAS WARNING	1	
7	87532ZH8810	MARK, OIL ALERT E	1	
8	87532ZJ1840	MARK, THROTTLE INDICATION	1	

PAYMENT TERMS

Terms of payment for parts are net 30 days.

FREIGHT POLICY

All parts orders will be shipped collect or prepaid with the charges added to the invoice. All shipments are F.O.B. point of origin. Multiquip's responsibility ceases when a signed manifest has been obtained from the carrier, and any claim for shortage or damage must be settled between the consignee and the carrier.

MINIMUM ORDER

The minimum charge for orders from Multiquip is \$15.00 net. Customers will be asked for instructions regarding handling of orders not meeting this requirement.

RETURNED GOODS POLICY

Return shipments will be accepted and credit will be allowed, subject to the following provisions:

1. A Returned Material Authorization must be approved by Multiquip prior to shipment.
2. To obtain a Return Material Authorization, a list must be provided to Multiquip Parts Sales that defines item numbers, quantities, and descriptions of the items to be returned.
 - a. The parts numbers and descriptions must match the current parts price list.
 - b. The list must be typed or computer generated.
 - c. The list must state the reason(s) for the return.
 - d. The list must reference the sales order(s) or invoice(s) under which the items were originally purchased.
 - e. The list must include the name and phone number of the person requesting the RMA.
3. A copy of the Return Material Authorization must accompany the return shipment.
4. Freight is at the sender's expense. All parts must be returned freight prepaid to Multiquip's designated receiving point.

5. Parts must be in new and resalable condition, in the original Multiquip package (if any), and with Multiquip part numbers clearly marked.
6. The following items are not returnable:
 - a. Obsolete parts. (If an item is in the price book and shows as being replaced by another item, it is obsolete.)
 - b. Any parts with a limited shelf life (such as gaskets, seals, "O" rings, and other rubber parts) that were purchased more than six months prior to the return date.
 - c. Any line item with an extended dealer net price of less than \$5.00.
 - d. Special order items.
 - e. Electrical components.
 - f. Paint, chemicals, and lubricants.
 - g. Decals and paper products.
 - h. Items purchased in kits.
7. The sender will be notified of any material received that is not acceptable.
8. Such material will be held for five working days from notification, pending instructions. If a reply is not received within five days, the material will be returned to the sender at his expense.
9. Credit on returned parts will be issued at dealer net price at time of the original purchase, less a 15% restocking charge.
10. In cases where an item is accepted, for which the original purchase document can not be determined, the price will be based on the list price that was effective twelve months prior to the RMA date.
11. Credit issued will be applied to future purchases only.

PRICING AND REBATES

Prices are subject to change without prior notice. Price changes are effective on a specific date and all orders received on or after that date will be billed at the revised price. Rebates for price declines and added charges for price increases will not be made for stock on hand at the time of any price change.

Multiquip reserves the right to quote and sell direct to Government agencies, and to Original Equipment Manufacturer accounts who use our products as integral parts of their own products.

SPECIAL EXPEDITING SERVICE

A \$35.00 surcharge will be added to the invoice for special handling including bus shipments, insured parcel post or in cases where Multiquip must personally deliver the parts to the carrier.

LIMITATIONS OF SELLER'S LIABILITY

Multiquip shall not be liable hereunder for damages in excess of the purchase price of the item with respect to which damages are claimed, and in no event shall Multiquip be liable for loss of profit or good will or for any other special, consequential or incidental damages.

LIMITATION OF WARRANTIES

No warranties, express or implied, are made in connection with the sale of parts or trade accessories nor as to any engine not manufactured by Multiquip. Such warranties made in connection with the sale of new, complete units are made exclusively by a statement of warranty packaged with such units, and Multiquip neither assumes nor authorizes any person to assume for it any other obligation or liability whatever in connection with the sale of its products. Apart from such written statement of warranty, there are no warranties, express, implied or statutory, which extend beyond the description of the products on the face hereof.

OPERATION AND PARTS MANUAL

HERE'S HOW TO GET HELP

PLEASE HAVE THE MODEL AND SERIAL
NUMBER *ON-HAND* WHEN CALLING

UNITED STATES

Multiquip Corporate Office

18910 Wilmington Ave. Tel. (800) 421-1244
Carson, CA 90746 Fax (800) 537-3927
Contact: mq@multiquip.com

Mayco Parts

800-306-2926 Fax: 800-672-7877
310-537-3700 Fax: 310-637-3284

Service Department

800-421-1244 Fax: 310-537-4259
310-537-3700

MQ Parts Department

800-427-1244 Fax: 800-672-7877
310-537-3700 Fax: 310-637-3284

Warranty Department

800-421-1244, Ext. 279 Fax: 310-537-1173
310-537-3700, Ext. 279

Technical Assistance

800-478-1244 Fax: 310-631-5032

MEXICO

MQ Cipsa

Carr. Fed. Mexico-Puebla KM 126.5 Tel: (52) 222-225-9900
Momoxpan, Cholula, Puebla 72760 Mexico Fax: (52) 222-285-0420
Contact: pmastretta@cipsa.com.mx

CANADA

Multiquip

4110 Industriel Boul. Tel: (450) 625-2244
Laval, Quebec, Canada H7L 6V3 Fax: (450) 625-8664
Contact: jmartin@multiquip.com

UNITED KINGDOM

Multiquip (UK) Limited Head Office

Hanover Mill, Fitzroy Street, Tel: 0161 339 2223
Ashton-under-Lyne, Fax: 0161 339 3226
Lancashire OL7 0TL
Contact: sales@multiquip.co.uk

BRAZIL

Multiquip

Av. Evandro Lins e Silva, 840 - grupo 505 Tel: 011-55-21-3433-9055
Barra de Tijuca - Rio de Janeiro Fax: 011-55-21-3433-9055
Contact: cnavarro@multiquip.com.br, srentes@multiquip.com.br

© COPYRIGHT 2006, MULTIQUIP INC.

Multiquip Inc and the MQ logo are registered trademarks of Multiquip Inc. and may not be used, reproduced, or altered without written permission. All other trademarks are the property of their respective owners and used with permission.

This manual MUST accompany the equipment at all times. This manual is considered a permanent part of the equipment and should remain with the unit if resold.

The information and specifications included in this publication were in effect at the time of approval for printing. Illustrations are based on the *AR-13H*. Illustrations, descriptions, references and technical data contained in this manual are for guidance only and may not be considered as binding. Multiquip Inc. reserves the right to discontinue or change specifications, design or the information published in this publication at any time without notice and without incurring any obligations.

Your Local Dealer is:

