

OPERATION & PARTS MANUAL



MAYCO SERIES MODEL C-30HDNI CONCRETE PUMP (PRECISION FUEL INJECTION)

UP TO S/N: 240601

Revision #4 (08/15/06)

To find the latest revision of this
publication, visit our website at:
www.multiquip.com



THIS MANUAL MUST ACCOMPANY THE EQUIPMENT AT ALL TIMES.



WARNING 

CALIFORNIA — Proposition 65 Warning

Engine exhaust and some of its constituents are known to the State of California to cause cancer, birth defects and other reproductive harm.

WARNING



SILICOSIS WARNING

Grinding/cutting/drilling of masonry, concrete, metal and other materials with silica in their composition may give off dust or mists containing crystalline silica. Silica is a basic component of sand, quartz, brick clay, granite and numerous other minerals and rocks. Repeated and/or substantial inhalation of airborne crystalline silica can cause serious or fatal respiratory diseases, including silicosis. In addition, California and some other authorities have listed respirable crystalline silica as a substance known to cause cancer. When cutting such materials, always follow the respiratory precautions mentioned above.

WARNING



RESPIRATORY HAZARDS

Grinding/cutting/drilling of masonry, concrete, metal and other materials can generate dust, mists and fumes containing chemicals known to cause serious or fatal injury or illness, such as respiratory disease, cancer, birth defects or other reproductive harm. If you are unfamiliar with the risks associated with the particular process and/or material being cut or the composition of the tool being used, review the material safety data sheet and/or consult your employer, the material manufacturer/supplier, governmental agencies such as OSHA and NIOSH and other sources on hazardous materials. California and some other authorities, for instance, have published lists of substances known to cause cancer, reproductive toxicity, or other harmful effects.

Control dust, mist and fumes at the source where possible. In this regard use good work practices and follow the recommendations of the manufacturers or suppliers, OSHA/NIOSH, and occupational and trade associations. Water should be used for dust suppression when wet cutting is feasible. When the hazards from inhalation of dust, mists and fumes cannot be eliminated, the operator and any bystanders should always wear a respirator approved by NIOSH/MSHA for the materials being used.

TABLE OF CONTENTS

MAYCO C-30HDNI (PRECISION) CONCRETE PUMP

- Proposition 65 Warning 2
- Silicosis Warning 3
- Table of Contents 4
- Parts Ordering Procedures 5
- Pump Specifications 6
- Engine Specifications 6
- Pump Dimensions 7
- Safety Message Alert Symbols 8-9
- Rules for Safe Operation 10-12
- Towing Guidelines 14-15
- Trailer Safety Guidelines 16-18
- Operation And Safety Decals 20
- Important Hand Signals 21
- Pump Components 22-23
- Control Box Components 24
- Engine Components 25
- General Information 26
- How it Works 27-28
- Operating Information 29-33
- Inspection 34-36
- Startup/Shutdown Procedures 37
- Maintenance (Pump) 38-47
- Engine Troubleshooting 48-49
- Malfunction Indicator Diagnostic Error Codes 50-53
- Component Location (EFI Wiring Harness) 54
- Wiring Diagram (EFI Wiring Harness) 55
- Wiring Diagram 56
- Wiring Diagram (Trailer Lights) 57
- Appendix —
 - Slump Test Procedure 58
 - Concrete Mix Information 59-61
 - Recommended Shotcrete System 62-63
 - Recommended Shotcrete Accessories 64-65
- Explanation of Codes in Remarks Column 66
- Suggested Spare Parts 67

COMPONENT DRAWINGS

- Nameplate and Decals 68-69
- Compensator Piston Rod Assembly 70-71
- Connecting Rod - Drive Side Assembly 72-73
- Rocker Assembly 74-75
- Countershaft Assembly 76-77
- Crankshaft Assembly 78-79
- Manifold Assembly 80-81
- Frame Assembly 82-83
- Axle Assembly 84-85
- Muffler, Air filter And Stop Switch Assembly 86-87
- Clutch Assy 88-89
- Radiator & Engine Mounting Bracket Assy. 90-91
- Radiator, Mounting And Hoses Assembly 92-93
- Control Box Assembly 94-95
- Battery Assembly 96-97
- Fuel Tank Assembly 98-99
- Hopper Assy 100 101
- Hood Assembly 102-103
- Lubrication Panel Assembly 104-105
- Remote Control Cable Assembly 106-107
- Precision Fuel Injection System 108-109

COMPONENT DRAWINGS (NISSAN ENGINE)

- Cylinder Block And Oil Pan Assembly 110-111
- Cylinder Head And Valve Cover Assembly 112-113
- Crankcase Ventilation Assembly 114-115
- Piston, Crankshaft And Flywheel Assembly ... 116-117
- Camshaft And Valve Mechanism Assembly ... 118-119
- Manifold Assembly 120-121
- Oil Pump Assembly 122-123
- Exhaust Tube and Muffler Assembly 124-125
- Water Pump Assembly 126-127
- Ignition System Assembly 128-129
- Distributor Assembly 130-131
- Alternator Assembly 132-133

- Terms and Conditions Of Sale — Parts 134
- Mayco Pump Warranty 135

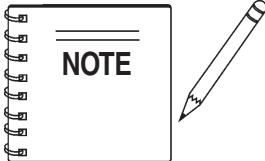

Specification and part number are subject to change without notice.

www.multiquip.com

Ordering parts has never been easier! Choose from three easy options:



Order via Internet (Dealers Only):

Order parts on-line using Multiquip's SmartEquip website!

- View Parts Diagrams
- Order Parts
- Print Specification Information



If you have an MQ Account, to obtain a Username and Password, E-mail us at: parts@multiquip.com.

To obtain an MQ Account, contact your District Sales Manager for more information.

Goto www.multiquip.com and click on **Order Parts** to log in and save!

Use the **internet** and qualify for a **5% Discount** on *Standard orders* for all orders which include complete part numbers.*

Note: Discounts Are Subject To Change



Order via Fax (Dealers Only):

All customers are welcome to order parts via Fax.

Domestic (US) Customers dial:
1-800-6-PARTS-7 (800-672-7877)

Fax your order in and qualify for a **3% Discount** on *Standard orders* for all orders which include complete part numbers.*

Note: Discounts Are Subject To Change



Order via Phone: Domestic (US) Dealers Call:
1-800-427-1244

Non-Dealer Customers:

Contact your local Multiquip Dealer for parts or call 800-427-1244 for help in locating a dealer near you.



International Customers should contact their local Multiquip Representatives for Parts Ordering information.

When ordering parts, please supply:

- | | |
|---|--|
| <input type="checkbox"/> Dealer Account Number | <input type="checkbox"/> Specify Preferred Method of Shipment: |
| <input type="checkbox"/> Dealer Name and Address | <input checked="" type="checkbox"/> Fed Ex/UPS <input checked="" type="checkbox"/> DHL |
| <input type="checkbox"/> Shipping Address (if different than billing address) | <input type="checkbox"/> Priority One <input checked="" type="checkbox"/> Truck |
| <input type="checkbox"/> Return Fax Number | <input type="checkbox"/> Ground |
| <input type="checkbox"/> Applicable Model Number | <input type="checkbox"/> Next Day |
| <input type="checkbox"/> Quantity, Part Number and Description of Each Part | <input type="checkbox"/> Second/Third Day |

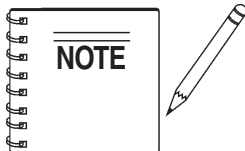

Unless otherwise indicated by customer, all orders are treated as *Standard Orders* and will ship within 24 hours. We will make every effort to ship *Air Shipments* the same day the order is received, if received prior to 2PM PST. *Stock Orders* must be noted on fax or web order form.

WE ACCEPT ALL MAJOR CREDIT CARDS!



C-30HDNI (PRECISION) PUMP — PUMP SPECIFICATIONS

TABLE 1. C-30HDN PUMP SPECIFICATIONS

Pump Type	Reciprocating Piston
Pumping Rate	Up to 25 cu. yds. per hour*
Vertical Pumping Height	Up to 150 ft. (45.73 m)
Horizontal Pumping Distance	400 - 500 ft. (122 - 152 m)*
Maximum Aggregate Size	1/2 in. minus (12.7 mm)
Hopper Capacity	6 cu. ft. etc.
Material Hose	2" or 2-1/2" (50.8 or 63.5 mm)
Weight	2,950 lbs. (1,338 Kg)
Lube oil Box	7 Gallons (26.5 Liters)
Remote Control	125 ft. cable Standard
Tire Size	7.35" x 14" (187 x 356 mm)
* Volume output will vary depending on mix design, slump, line size used and job site conditions.	

Table 2. Engine Specifications

		NISSAN A15 INDUSTRIAL ENGINE
Engine	Model	NISSAN A15 INDUSTRIAL ENGINE
	Type	4 stroke, overhead valve, single cylinder, horizontal shaft gasoline engine
	Bore X Stroke	2.99 x 3.23 in. (76 x 82 mm)
	Compression Ratio	9.0:1
	Displacement	90.784 cu. (1,487 cc)
	Continuous Output	51 H.P./3600 R.P.M.
	Fuel Tank Capacity	Approx. 11 U.S. Gallons (53 liters)
	Fuel Cell	Unleaded Automobile Gasoline
	Lube Oil Capacity	3.2 liters (3-3/8 qt)
	Engine Speed Full Load	2650 rpm ±100 (No Load 2750 rpm +/- 50) (Load 2750 rpm +/- 100)
	Engine Speed Full Idle	875 rpm ±100
	Air Cleaner	Air Horn Type
	Engine Lubrication	SAE 10W-30 (Oil Grade) SG or SF (Service Class)
	Starting Method	Electric Start
Spark Plug	B4ES	
Spark Plug Gap	0.8 - 0.9 in. (0.031-0.035 mm)	
Dimension (L x W x H)	20.78 x 20.90 x 22.69 in. (527.8 x 530.8 x 576.3 mm)	
Dry Net Weight	227 lbs (103 Kg.)	

C-30HDNI (PRECISION) PUMP — PUMP DIMENSIONS

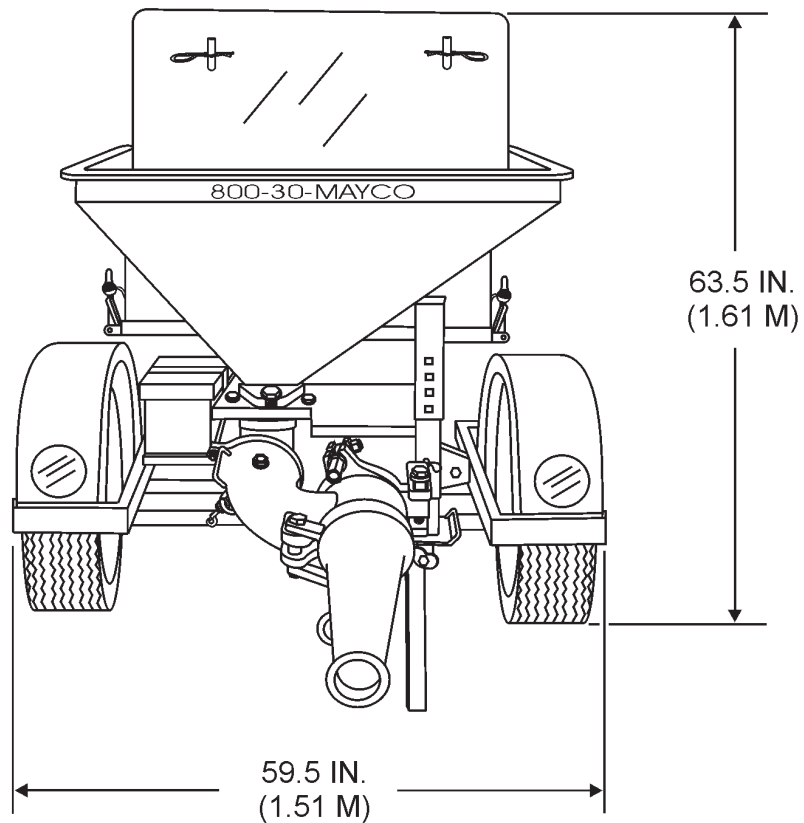
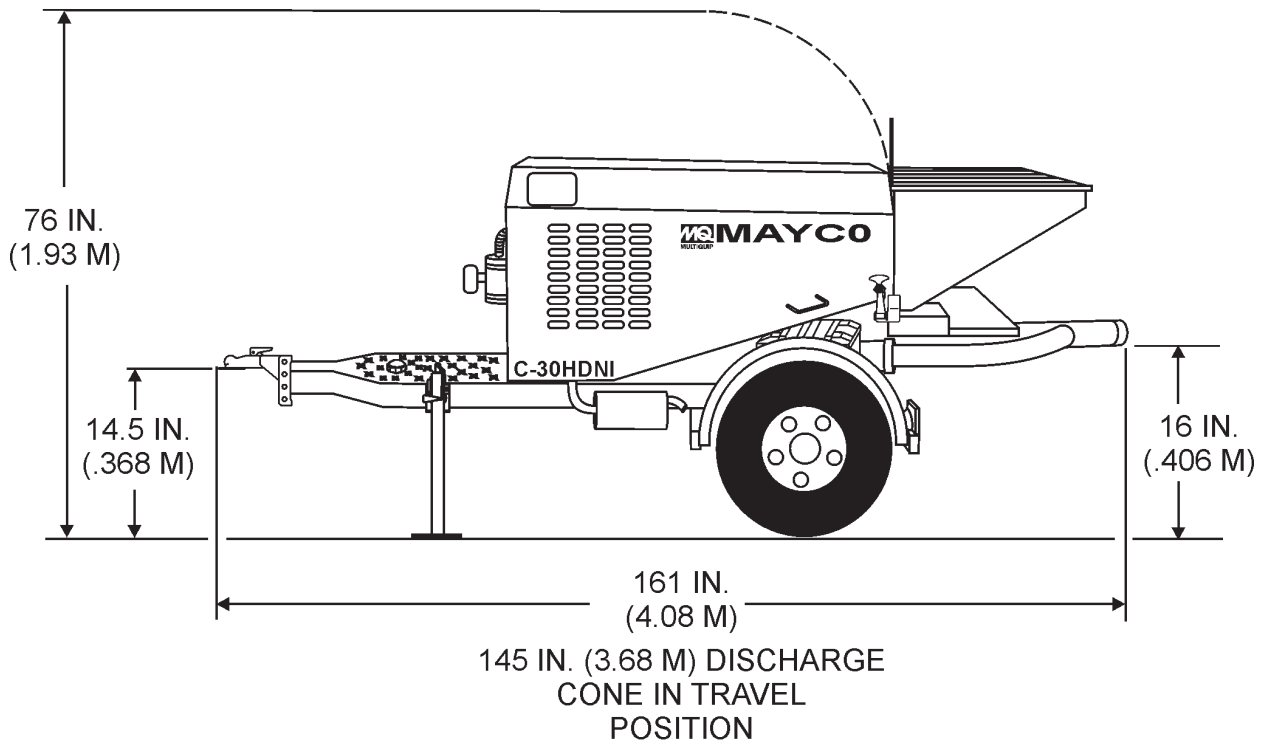
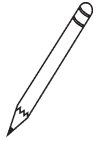

Figure 1. C-30HDNI Concrete Pump Dimensions

C-30HDNI (PRECISION) PUMP — SAFETY MESSAGE ALERT SYMBOLS

FOR YOUR SAFETY AND THE SAFETY OF OTHERS!

Safety precautions should be followed at all times when operating this equipment. Failure to read and understand the Safety Messages and Operating Instructions could result in injury to yourself and others.



This Owner's Manual has been developed to provide complete instructions for the safe and efficient operation of the Mayco Model C-30HDNI Concrete Pump.

Refer to the engine manufacturers instructions for data relative to its safe operation.

Before using this pump, ensure that the operating individual has read and understands all instructions in this manual.

SAFETY MESSAGE ALERT SYMBOLS

The three (3) Safety Messages shown below will inform you about potential hazards that could injure you or others. The Safety Messages specifically address the level of exposure to the operator, and are preceded by one of three words: **DANGER**, **WARNING**, or **CAUTION**.

DANGER

You **WILL** be **KILLED** or **SERIOUSLY** injured if you do not follow directions.

WARNING

You **COULD** be **KILLED** or **SERIOUSLY** injured if you do not follow directions.

CAUTION

You **CAN** be injured if you do not follow directions

HAZARD SYMBOLS

Potential hazards associated with operation of the pump will be referenced with Hazard Symbols which appear throughout this manual, and will be referenced in conjunction with Safety Message Alert Symbols. Some examples are listed below:

WARNING - LETHAL EXHAUST GASES



Gasoline engine exhaust gases contain poisonous carbon monoxide. This gas is colorless and odorless, and can cause death if inhaled. **NEVER** operate this equipment in a confined area or enclosed structure that does not provide ample free flow air.

WARNING - EXPLOSIVE FUEL



Gasoline is extremely flammable, and its vapors can cause an explosion if ignited. **DO NOT** start the engine near spilled fuel or combustible fluids. **DO NOT** fill the fuel tank while the engine is running or hot.

DO NOT overfill tank, since spilled fuel could ignite if it comes into contact with hot engine parts or sparks from the ignition system. Store fuel in approved containers, in well-ventilated areas and away from sparks and flames. **NEVER** use fuel as a cleaning agent.

WARNING - BURN HAZARDS



Engine components can generate extreme heat. To prevent burns, **DO NOT** touch these areas while the engine is running or immediately after operations. **NEVER** operate the engine with heat shields or heat guards removed.

C-30HDNI (PRECISION) PUMP — SAFETY MESSAGE ALERT SYMBOLS

WARNING - ROTATING PARTS



NEVER operate equipment with covers, or guards removed. Keep **fingers, hands, hair** and clothing away from all moving parts to prevent injury.

CAUTION - RESPIRATORY HAZARDS



ALWAYS wear approved **respiratory** protection.

CAUTION - ACCIDENTAL STARTING



ALWAYS place the **Engine ON/OFF** switch in the **OFF** position and remove the ignition key when the pump is not in use.

CAUTION - SIGHT AND HEARING HAZARDS

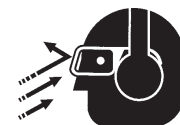

ALWAYS wear approved **eye** and **hearing** protection.

CAUTION - OVER-SPEED CONDITIONS



NEVER tamper with the factory settings of the engine governor or settings. Personal injury and damage to the engine or equipment can result if operating in speed ranges above maximum allowable.

CAUTION - EQUIPMENT DAMAGE MESSAGES

Other important messages are provided throughout this manual to help prevent damage to your concrete pump, other property, or the surrounding environment.

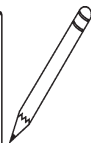
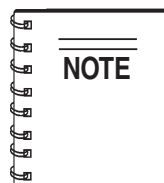

This **pump**, other property, or the surrounding environment could be damaged if you do not follow instructions.

C-30HDNI (PRECISION) PUMP — RULES FOR SAFE OPERATION

DANGER - Read This Manual!

Failure to follow instructions in this manual may lead to serious injury or even death! This equipment is to be operated by trained and qualified personnel only! This equipment is for industrial use only.

The following safety guidelines should always be used when operating the Mayco C-30HDNI Concrete Pump:

General Safety



- **DO NOT** operate or service this equipment before reading this entire manual.
- **ALWAYS** read, understand, and follow procedures in Operator's Manual before attempting to operate equipment. 
- **ALWAYS** be sure the operator is familiar with proper safety precautions and operations techniques before using pump
- This equipment should not be operated by persons under 18 years of age.
- **ALWAYS** read, understand and follow procedures in Operator's Manual before attempting to operate equipment.
- **ALWAYS** be sure the operator is familiar with proper safety precautions and operations techniques before using pump
- **NEVER** operate this equipment without proper protective clothing, shatterproof glasses, steel-toed boots and other protective devices required by the job.



- **NEVER** operate this equipment when not feeling well due to fatigue, illness or taking medicine. 
- **NEVER** operate this equipment under the influence of **drugs** or **alcohol**.

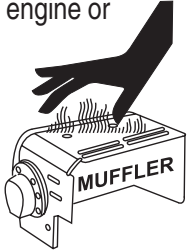
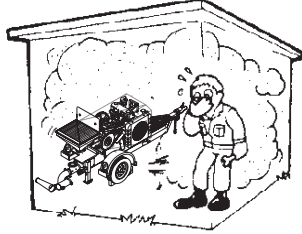

- **ALWAYS** wear proper respiratory (mask), hearing and eye protection equipment when operating the concrete pump. 

- Whenever necessary, replace nameplate, operation and safety decals when they become difficult read.
- Manufacture does not assume responsibility for any accident due to equipment modifications.
- **NEVER** use accessories or attachments, which are not recommended by Multiquip for this equipment. Damage to the equipment and/or injury to user may result.
- **NEVER** touch the hot exhaust manifold, muffler or cylinder. Allow these parts to cool before servicing engine or concrete pump.
- **High Temperatures** – Allow the engine to cool before adding fuel or performing service and maintenance functions. Contact with **hot!** components can cause serious burns. 
- The engine section of this concrete pump requires an adequate free flow of cooling air. **NEVER** operate the concrete pump in any enclosed or narrow area where free flow of the air is restricted. If the air flow is restricted it will cause serious damage to the concrete pump or engine and may cause injury to people. Remember the concrete pump's engine gives off **DEADLY** carbon monoxide gas. 
- **ALWAYS** refuel in a well-ventilated area, away from sparks and open flames.
- **ALWAYS** use extreme caution when working with **flammable** liquids. When refueling, **stop the engine** and allow it to cool. **DO NOT smoke** around or near the machine. Fire or explosion could result from fuel vapors, or if fuel is spilled on a hot engine.
- **NEVER** operate the concrete pump in an explosive atmosphere or near combustible materials. An explosion or fire could result causing severe **bodily harm or even death**. 
- Topping-off to filler port is dangerous, as it tends to spill fuel.
- Stop the engine when leaving the concrete pump unattended.
- **DO NOT** leave the pump unattended. Use chock blocks if parking pump on a grade.
- Maintain this equipment in a safe operating condition at all times.

C-30HDNI (PRECISION) PUMP — RULES FOR SAFE OPERATION

- **CAUTION** must always be observed while servicing this pump. Rotating parts can cause injury if contacted.
- **ALWAYS** stored the pump in a clean, dry location out of the reach of children.
- **ALWAYS** use extreme care when operating near obstructions, on slippery surfaces, grades and side slopes.
- Unauthorized equipment modifications will void all warranties.
- Refer to the *Engine Owner's Manual* for engine technical questions or information.
- Before start-up, check the hopper and remove all obstructions.
- Keep all hands out of the hopper when the engine is running.
- **DO NOT** operate the pump with the hood open.
- Replace any worn or damaged pump components immediately.
- **ALWAYS** turn the engine **OFF** before performing must be before performing maintenance.
- **ALWAYS** make sure pump is correctly secured to the trailer. Check all supports attaching the pump to the trailer and make sure they are tight.
- **ALWAYS** make sure that the pump's trailer is placed on solid level ground so that it cannot slide or shift around, endangering workers. Place blocks under the trailer's bumper to make it level (prevents tipping), and use a chocked block underneath the wheels to prevent rolling. Also keep the immediate area free of bystanders.
- Before towing, check the hitch and secure the safety chain to the towing vehicle. Also check for proper tire pressure.
- Tow only with a vehicle and hitch rated to tow a 2,950 lbs. (1,338 Kg) load.
- If pump is equipped with ball hitch coupler, use only a 2" all steel ball rated for a minimum of 5000 lbs. Use a 1" hardened steel pull pin, if the pump is equipped with a pin hitch.
- **ALWAYS** check the machine for loosened threads or bolts before starting.
- A copy of this manual shall accompany the pump at all times.
- **DO NOT** use worn out hoses or couplings; inspect daily.
- **DO NOT** disconnect the hose couplings or nozzle while they are under pressure. Relieve the pressure by manually swinging the clamp arm latch handle to the first open position at the exhaust cone outlet.
- The pump should **NEVER** be towed in excess of 45 MPH (or less depending on road conditions).
- If hose lines are **blocked** for any reason, or if the lines are **kinked** when starting up or during pumping cycle, the pump pressure could straighten out the kink or force out the blockage. This rapid surge of material could cause the lines to **move or whip** in a manner that could cause injury to personnel.
- Inspect the hose lines at all times
- **DO NOT** tow the pump with the hopper full of material.
- **DO NOT** tow the pump with the hoses attached.
- **NEVER** disconnect any **emergency or safety devices**. These devices are intended for operator safety. Disconnection of these devices can cause severe injury, bodily harm or even death! Disconnection of any of these devices will void all warranties.

C-30HDNI (PRECISION) PUMP — RULES FOR SAFE OPERATION

Maintenance Safety

- **NEVER** lubricate components or attempt service on a running machine.
- **ALWAYS** allow the machine a proper amount of time to cool before servicing.
- Keep the machinery in proper running condition.
- Fix damage to the machine immediately and always replace broken parts.
- Dispose of hazardous waste properly. Examples of potentially hazardous waste are used motor oil, fuel and fuel filters.
- **DO NOT** use food or plastic containers to dispose of hazardous waste.
- **DO NOT** pour waste, oil or fuel directly onto the ground, down a drain or into any water source.

Lifting

- The pump has an operating weight of approximately 2,950 lbs. (1,338 Kg). Use lifting equipment capable of lifting this weight.

Emergencies

- **ALWAYS** know the location of the nearest **fire extinguisher** and **first aid kit**. Know the location of the nearest telephone. Also know the phone numbers of the nearest **ambulance**, **doctor** and **fire department**. This information will be invaluable in the case of an emergency.

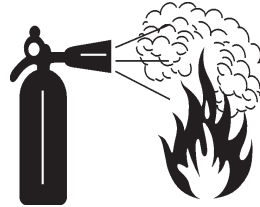

C-30HDNI (PRECISION) PUMP — TOWING GUIDELINES

Towing Safety Precautions

CAUTION - Local Towing Regulations

Check with your county or state safety towing regulations department before towing your concrete pump.

To reduce the possibility of an accident while transporting the pump on public roads, always make sure that the trailer and the towing vehicle are in good operating condition and both units are mechanically sound.

The following list of suggestions should be used when towing the pump:

- Make sure that the hitch and coupling of the towing vehicle are rated equal to, or greater than the trailer "gross vehicle weight rating" (GVWR).
- **ALWAYS** inspect the hitch and coupling for wear. **NEVER** tow the light tower's trailer with defective hitches, couplings, chains etc.
- **CHECK** the tire air pressure on both the towing vehicle and the trailer. Also check the tire tread wear on both vehicles.
- **ALWAYS** make sure the trailer section of the pump is equipped with a "Safety Chain".
- **ALWAYS** attach trailer's safety chain to frame of towing vehicle.
- **ALWAYS** make sure that the vehicle and trailer directional, backup, brake, and trailer lights are connected properly and are working properly.
- Remember in most cases the maximum speed unless otherwise posted for highway towing is 45 MPH, however before towing your pump, check your local state, and county vehicle towing requirements. Recommended off-road towing is not to exceed **10 MPH** or less depending on type of terrain.
- Place *chocked blocks* underneath wheel to prevent **rolling**, while parked.
- Depending on soil conditions and location it may be necessary to place *support blocks* underneath the trailer's bumper to prevent **tipping**, while parked.
- Inflate tires to correct pressure, inspect tires for cuts, and excessive wear. See Table 3 (Tire Wear Troubleshooting).

- Check wheel mounting lug nuts with a **torque wrench**. Torque wheel lug nuts as described in the "**Lug Nut Torque Requirements**", Table 5.
- Make sure brakes are synchronized and functioning properly.
- Check tightness of suspension hardware (nuts and bolts).
- Avoid sudden stops and starts. This can cause skidding, or jackknifing. Smooth, gradual starts and stops will improve gas mileage.
- Avoid sharp turns to prevent rolling.
- Retract wheel stand when transporting.
- **DO NOT** transport pump with fuel in the fuel tank.

CAUTION - Never Use Defective Couplers

If the trailer coupler is deformed replace entire coupler. **NEVER** tow the pump with a defective trailer coupler. There exist the possibility of the trailer separating from the towing vehicle.

Pump Trailer Vehicle Connection

1. Check the vehicle hitch ball, and trailer coupler for signs of wear or damage. Replace any parts that are worn or damaged before towing.
2. Use only the 2-inch ball diameter with a towing capability of 5,000 lbs. (2,268 kg) as indicated on the trailer's coupler. Use of any other ball diameter will create an extremely dangerous condition which can result in separation of the coupler and ball or ball failure.
3. Be sure the coupler is secured to the hitch ball and the lock lever is down (locked).
4. Attach safety chains as shown in Figure 2. Remember to **cross** the safety chains.
5. After towing for about 50 miles recheck the entire towing system for tightness.

Recommended Maintenance

1. Smear ball socket and clamp face with chassis grease. Periodically oil pivot points and wear surfaces of coupler with SAE 30 W motor oil.
2. When parking or storing the concrete pump, keep the coupler off the ground so dirt and other debris will not build up in the ball socket.

C-30HDNI (PRECISION) PUMP — TOWING GUIDELINES

Figure 2 shown below illustrates the typical towing application that should be used when towing the pump.

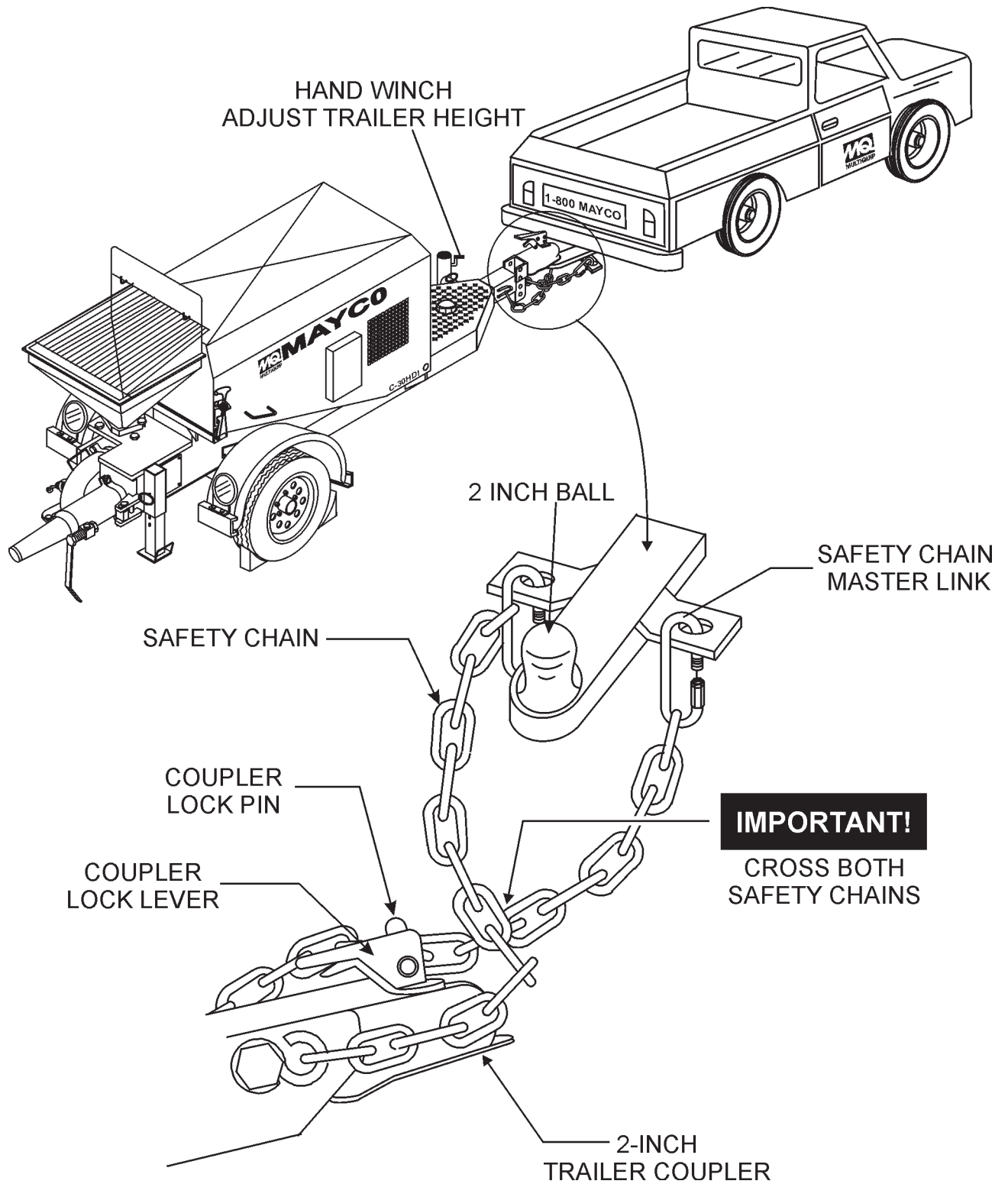

Figure 2. Towing Applications

C-30HDNI (PRECISION) PUMP — TRAILER SAFETY GUIDELINES

Trailer Safety Precautions

CAUTION - General Trailer Safety

ALWAYS make sure that the trailer is in good operating condition. Check the tires for proper inflation and wear. Also check the wheel lug nuts for proper tightness.

This section is intended to provide the user with trailer service and maintenance information. Remember periodic inspection of the trailer will ensure safe towing of the equipment and will prevent damage to the equipment and personal injury.

It is the purpose of this section to cover the major maintenance components of the trailer. The following trailer components will be discussed in this section:

- Tires
- Lug Nut Torquing
- Suspension
- Electrical

The following list defines the major trailer components:

1. **Fuel Cell** – Provides an adequate amount of fuel for the equipment in use. Fuel cells must be empty when transporting equipment.
2. **Frame Length** – This measurement is from the ball hitch to the rear bumper (reflector).
3. **Frame Width** – This measurement is from fender to fender.
4. **Jack Stand** – Trailer support device with maximum pound requirement from the tongue of the trailer.
5. **Coupler** – Type of hitch used on the trailer for towing. This unit employs a 2 in. ball.
6. **Tires Size** – Indicates the diameter of the tire in inches (10, 12, 13, 14, etc.), and the width in millimeters (175, 185, 205 etc.). The tire diameter must match the diameter of the tire rim. This unit employs 7.35 x 14 in. tires.
7. **Tires Ply** – The tire ply (layers) number is rated in letters: 2-ply, 4-ply, 6-ply, 8-ply, 10-ply etc. This unit employs 4-ply tires.
8. **Wheel Hub** – The wheel hub is connected to the trailer's axle.
9. **Tire Rim** – Tires are mounted on a tire rim. The tire rim must match the size of the tire.
10. **Lug Nuts** – Used to secure the wheel to the wheel hub. Always use a torque wrench to tighten down the lug nuts. See Table 5 and Figure 4 for lug nut tightening and sequence. This unit employs 5 lug nuts to secure the wheel to the hub.
11. **Axle** – This trailer employs a torsion bar type suspension, which can support 3,500 lbs.
12. **Electrical** – Electrical connectors (looms) are provided with the trailer so that brake lights and turn signal lights can be connected to the towing vehicle. See **Trailer Wiring Diagram** for proper wiring connections.

C-30HDNI (PRECISION) PUMP — TRAILER SAFETY GUIDELINES

Tires/Wheels/Lug Nuts

Tires and wheels are a very important and critical components of the trailer. When specifying or replacing the trailer wheels it is important the wheels, tires, and axle are properly matched.

CAUTION - General Trailer Safety

DO NOT attempt to repair or modify a wheel. **DO NOT** install an inter-tube to correct a leak through the rim. If the rim is cracked, the air pressure in the inter-tube may cause pieces of the rim to explode (break-off) with great force and can cause serious eye or bodily injury.

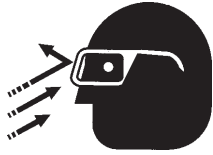





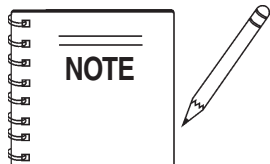

Tires Wear/Inflation

Tire inflation pressure is the most important factor in tire life. Pressure should be checked cold before operation. **DO NOT** bleed air from tires when they are hot. Check inflation pressure weekly during use to insure the maximum tire life and tread wear.

Table 3 (Tire Wear Troubleshooting) will help pinpoint the causes and solutions of tire wear problems.



ALWAYS wear safety glasses when removing or installing force fitted parts. Failure to comply may result in serious injury.

TABLE 4 TIRE WEAR TROUBLESHOOTING			
WEAR PATTERN	CAUSE	SOLUTION	
	Center Wear	Over Inflation	Adjust pressure to particular load per tire manufacturer.
	Edge Wear	Under Inflation	Adjust pressure to particular load per tire manufacturer.
	Side Wear	Loss of chamber or overloading.	Make sure load does not exceed axle rating. Align wheels.
	Toe Wear	Incorrect toe-in	Align wheels.
	Cupping	Out-of balance	Check bearing adjustment and balance tires.
	Flat Spots	Wheel lockup & tire skidding.	Avoid sudden stops when possible and adjust brakes.

Torsion Bar Suspension

The torsion bar suspension and associated hardware (Figure 3) should be visually inspected every 6,000 miles for signs of excessive wear, elongation of bolt holes, and loosening of fasteners. Replace all damaged parts (suspension) immediately.

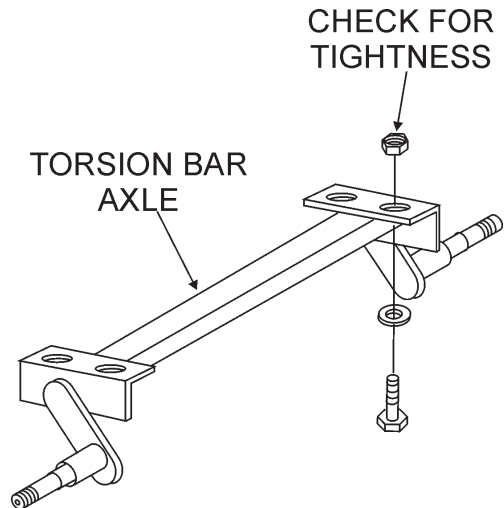

Figure 3. Major Suspension Components

C-30HDNI (PRECISION) PUMP — TRAILER SAFETY GUIDELINES

Lug Nut Torque Requirements

It is extremely important to apply and maintain proper wheel mounting torque on the trailer. Be sure to use only the fasteners matched to the cone angle of the wheel. Proper procedure for attachment of the wheels is as follows:

1. Start all wheel lug nuts by hand.
2. Torque all lug nuts in sequence (Figure 4). **DO NOT** torque the wheel lug nuts all the way down. Tighten each lug nut in 3 separate passes as defined by Table 4.
3. After first road use, retorque all lug nuts in sequence. Check all wheel lug nuts periodically.

Wheel Size	First Pass FT-LBS	Second Pass FT-LBS	Third Pass FT-LBS
12"	20-25	35-40	50-65
13"	20-25	35-40	50-65
14"	20-25	50-60	90-120
15"	20-25	50-60	90-120
16"	20-25	50-60	90-120

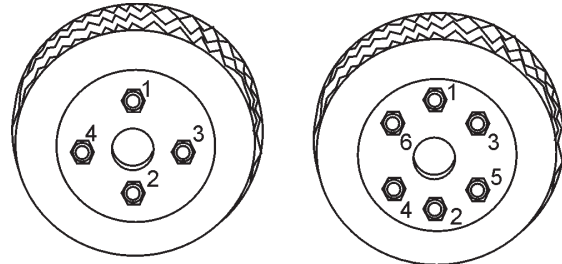

4-LUG NUTS

6-LUG NUTS

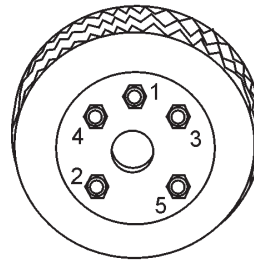

5-LUG NUTS

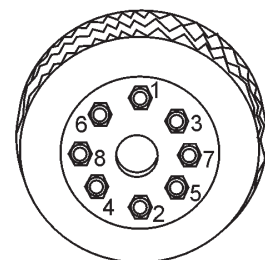

8-LUG NUTS

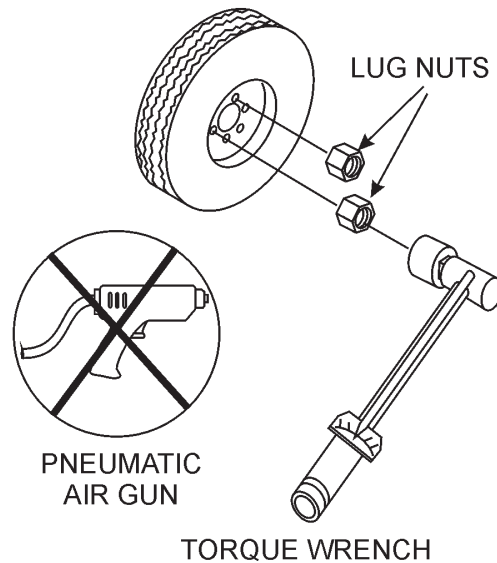
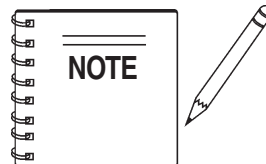

Figure 4. Wheel Lug Nuts Tightening Sequence



NEVER! use an pneumatic air gun to tighten wheel lug nuts.

C-30HDNI (PRECISION) PUMP — OPERATION AND SAFETY DECALS

Figure 5 displays the operation and safety decals as they appear on the concrete pump, should any of these decals become damaged or unreadable, contact the Multiquip Parts Department for a replacement set.

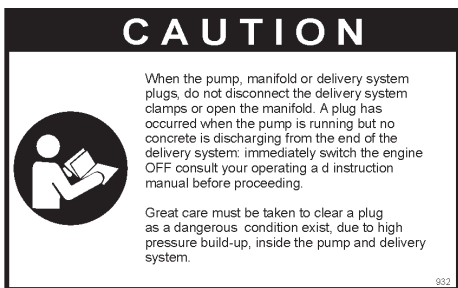

P/N EM932

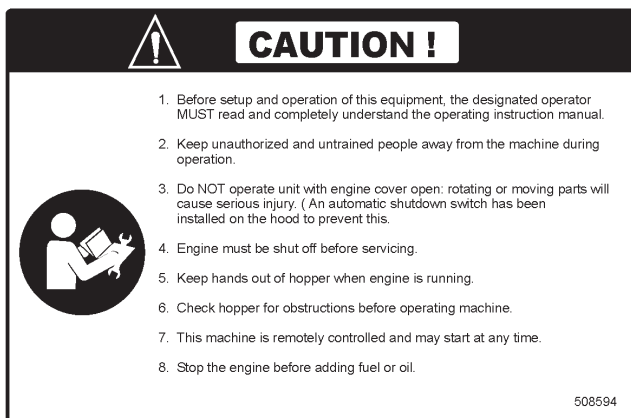

P/N 508594

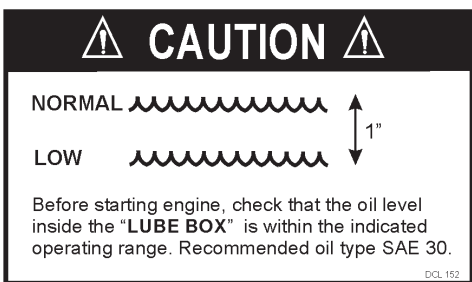

P/N DCL152

C-30HDNI

P/N TBD



P/N EM513165



P/N 34536

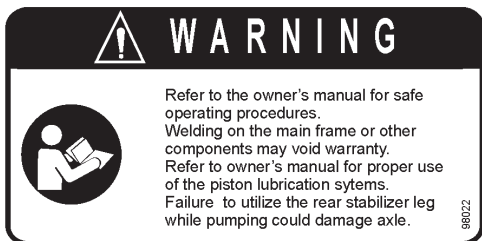

P/N 98022

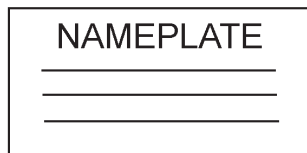

CONTACT MULTIQUIP
SERVICE DEPT.



P/N EM1028

Figure 5. Operation and Safety Decals

C-30HDNI (PRECISION) PUMP — IMPORTANT HAND SIGNALS

Figure 6 display's the basic hand signals commonly used in concrete pumping operations.

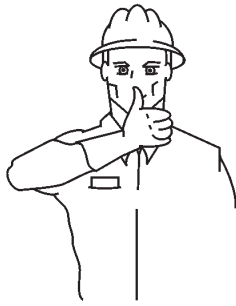

CHUTE UP



CHUTE UP



STOP



START PUMP
SPEED UP

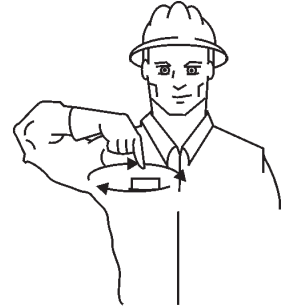

SLOW PUMP
DOWN



STOP PUMP



LITTLE BIT



ADD WATER
4-GALLONS



ALL DONE
CLEAN-UP



DRIVE IN

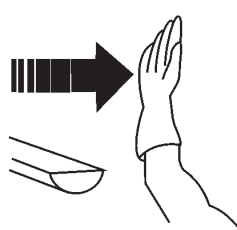

BACK UP

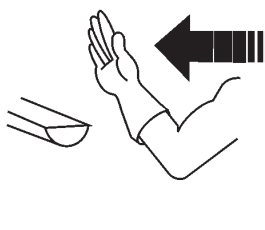

PULL FORWARD



BACK IN

Figure 6. Operation Hand Signals

C-30HDNI (PRECISION) PUMP — PUMP COMPONENTS

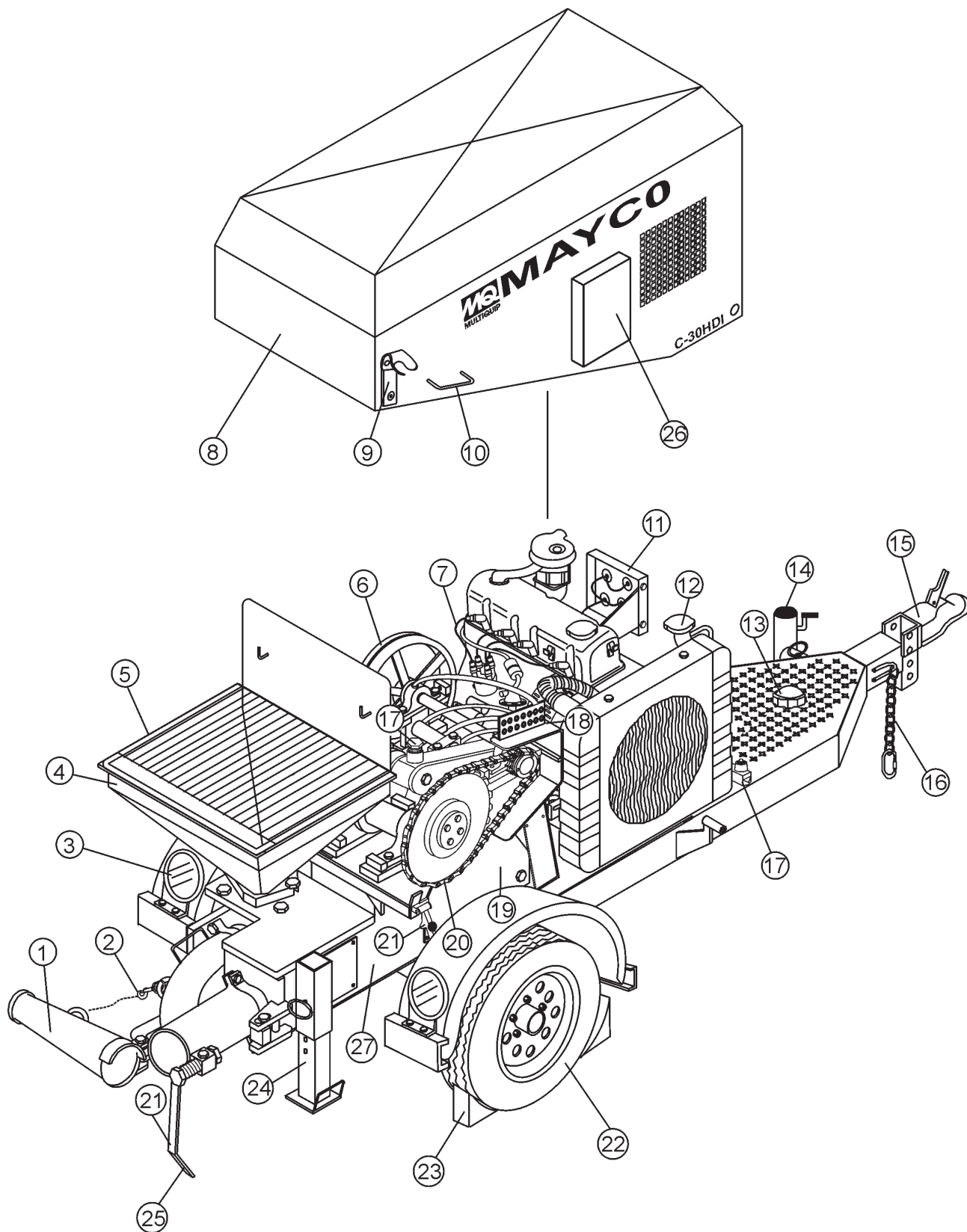

Figure 7. Major Pump Components

C-30HDNI (PRECISION) PUMP — PUMP COMPONENTS

Figure 7 illustrates the location of the major components for the C-30HDNI Concrete Pump. The function of each component is described below:

1. **Discharge Cone** – Connect 3" elbow to this discharge port, then connect 3" x 2" reducer to elbow.
2. **Discharge Cone Safety Latch** – When towing of the pump is required, **ALWAYS** secure the discharge cone to latch located on the manifold.
3. **Rear Running Lights** – **ALWAYS** check and make sure both the right and left running lights are functioning correctly before towing the pump.
4. **Hopper** – Concrete from a Redi-Mix truck is poured into this hopper. The hopper can hold 6.0 cu. ft of concrete. **NEVER** put hands or any other parts of you body into the hopper.
5. **Safety Grill** – The safety grill should be locked at all times when the pump is being towed. Under normal working conditions, raise and place the safety grill on the support hooks which are located on splash guard.
6. **Shaft Pulley V-Belt** – **ALWAYS** inspect the drive shaft V-belt for wear and alignment. A defective or misaligned V-belt can wear prematurely and adversely affect the performance of the pump. Replace with only manufactures recommended type V-belt.
7. **Distributor** – **NEVER** allow concrete, water or any foreign debris to come in contact with the distributor.
8. **Compartment Hood** – **NEVER** operate the pump with the hood removed. Installed on the pump frame is a safety interlock device which prevents the engine from starting if the hood is removed or in the up position (open).
9. **Hood Fastener** – When the hood is in the down position, secure the rubber latch to this fastener.
10. **Hood Lift Handle** – Grip this handle, pull upward then back to raise the compartment hood.
11. **Control Box** – Contains the mechanical and electrical components required to run the pump. Below is a list of those components:
 - Throttle Control
 - Low Oil Pressure Indicator
 - Battery Charge Indicator
 - Water Temperature Indicator
 - Ignition Switch
 - Remote Connector
12. **Radiator/Cap** – Fill with a water/anti-freeze type solution as recommended in the maintenance section of this manual. **ALWAYS** make sure that the radiator is filled to the proper operating level before starting the engine.
13. **Fuel Tank/Cap** – Fill with unleaded fuel. Fuel tank (cell) holds approximately 11 gallons (42 liters). **DO NOT** top off fuel. Wipe up any spilled fuel immediately
14. **Tow End Jack Stand** – Use this jack stand to level and support the pump.
15. **Tow Hitch Coupler** – Requires a 2-inch ball hitch or a 3-inch pintle. Capable of towing 5,000 lbs.
16. **Safety Chain** – **ALWAYS** attach safety chain to the towing vehicle. **NEVER!** tow the pump with the safety chain unattached.
17. **Engine Stop Device** – This device will prevent the starting of the engine when the compartment hood is in the **UP** position. The compartment hood must be in the **DOWN** position in order for the engine to start.
18. **Grease Port Console** – This console allows for the remote lubrication of components on the pump.
19. **Access Door** – There are four access doors on the pump. Remove these door to gain access to drive and piston assemblies when maintenance is required.
20. **Drive Chain** – Keep this chain properly lubricated and aligned at all times. Lubricate this chain as specified in the maintenance section of this maintenance.
21. **Rubber Latch** – Secure this rubber latch to the hood fastener whenever the pump is in use or being towed.
22. **Tires Ply**– The tire ply (layers) number is rated in letters; This trailer uses 4-ply tires.
23. **Chock Blocks** – Place these blocks (not included as part of your concrete pump package) under each trailer wheel to prevent rolling.
24. **Pump End Jack Stand** – Use this jack stand to level and support the pump.
25. **Discharge Cone Release Lever** – secures the discharge cone to the "Y" manifold; also relieves manifold pressure.
26. **Documentation Box** – Contains engine and pump operation, parts and maintenance information.
27. **Lubrication Box** – This box is empty when shipped from the factory. Please fill with 7 gallons (26.5 liters) of SAE motor oil for first time use. Also check the dual clean-out point on bottom of lubrication box for a secure tight fit.

C-30HDNI (PRECISION) PUMP — CONTROL BOX COMPONENTS

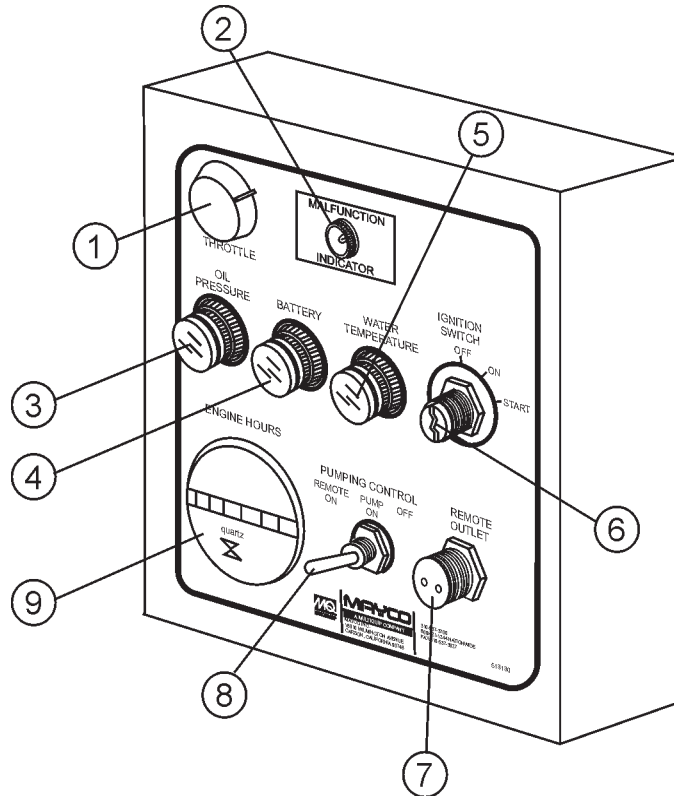

Figure 8. Pump Control Box Components

Figure 8 illustrates the location of the major components for the C-30HDNI Control Box. The function of each component is described below:

1. **Throttle Control Switch** – This is a variable speed type control. Holding the control switch to the **left** increases the engine speed. To place the engine at **IDLE** speed, hold the control switch to the **right** and let the engine run for 3-5 minutes.
2. **Trouble Indicator LED**– This is a diagnostic feature on the C-30HDNI to assist the operator with identifying problems that occur with the fuel injection system (See Table 7).
3. **Oil Pressure Indicator Lamp** – In the event of low oil in the engine crankcase or low oil pressure, the oil "**Oil Pressure Lamp**" indicator will be lit. **STOP** the engine immediately if this lamp is lit. **NEVER** run the engine when this lamp is on.
4. **Battery Charge Indicator Lamp** – Indicates if the electrical system is charging properly. If the "**Battery Charge Indicator Lamp**" is lit, this is an indication that the charging system is malfunctioning. **STOP** the engine and remedy the electrical charging problem.
5. **Water Temperature Lamp** – In the event of high engine water temperature (220 degrees Fahrenheit), this lamp will be lit. **STOP** the engine immediately if this lamp comes on. **NEVER** run the engine when this lamp is on.
6. **Ignition Switch** – Insert the ignition key here to start the engine. Turn the key clockwise to the **ON** position, then continue turning clockwise to the **START** position and release. To stop the engine turn the key fully counter-clockwise to the **STOP** position.
7. **Remote Control Input Connector** – Insert the remote control input cable into this connector.
8. **Pumping Control Switch** – This 3-position switch controls the pumping of the pump. The **left most** position is for use with the remote control unit, the **center** position is for off (prevents pumping), and the **right most** position is for normal pump operation.
9. **Hourmeter**– Display's the number of hours the pump has been in use.

C-30HDNI (PRECISION) PUMP — ENGINE COMPONENTS

FRONT VIEW

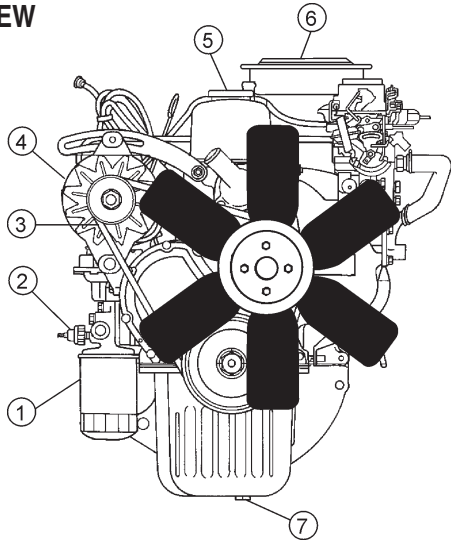

TOP VIEW

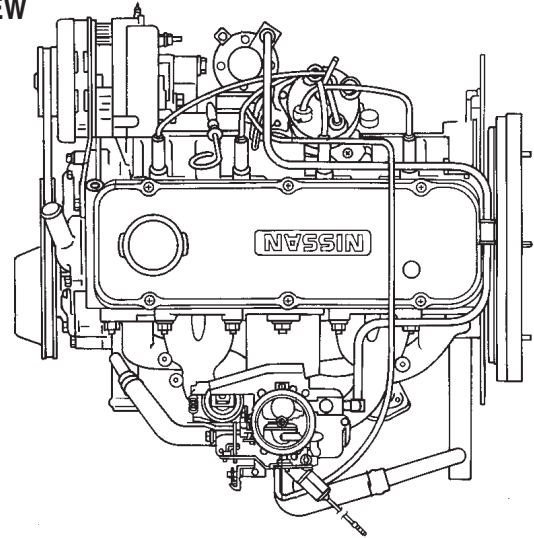
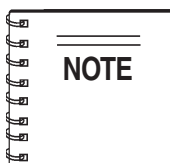

Figure 9. Nissan Model A15 Basic Engine Components

Figure 9 illustrates the location of the basic components for the NISSAN A-15 Engine. The function of each component is described below:

1. **Oil Filter** – Replace this filter as recommended in the maintenance section of this manual
2. **Oil Pressure Switch** – In the event of low oil level, this switch will shutdown the engine.
3. **Starter Motor/Solenoid** – **NEVER** allow concrete or any foreign debris to come in contact with the starter motor/solenoid.
4. **Fan V-Belt** – **ALWAYS** make sure that V-belt is properly tensioned. A loose or defective V-belt can adversely affect the performance of the pump.
5. **Alternator** – Provides power to the electrical system. Replace with only manufactures recommended type alternator.
6. **Air Cleaner** – Prevents dirt and other debris from entering the fuel system. Remove wing-nut on top of air filter cannister to gain access to filter element. Replace with only manufactures recommended type air cleaner.
7. **Cooling Fan Blades** – Make sure that the blades of the cooling fan are not **bent or broken**. A damaged fan blade can cause the engine to run hot and overheat.
8. **Crankcase Drain Plug** – Remove this plug to drain engine oil from the crankcase. Replace with recommended engine oil as specified in the maintenance section of this manual.
9. **Fuel Pump/Fuel Filter** – Replace or clean the fuel pump or fuel filter as specified in the maintenance section of this manual.
10. **Distributor** – **NEVER** allow concrete or any foreign debris to come in contact with the distributor.
11. **Spark Plug** – Provides spark to the ignition system. Set spark plug gap to 0.6 - 0.7 mm (0.028 - 0.031 inch). Clean spark plug once a week.
12. **Dipstick** – Remove this dipstick to determine if engine oil is low. Maintain oil level at the "H" marking on the dipstick. **NEVER** run engine with low oil.
13. **Oil Filler Port Cap** – Remove this cap to add engine oil to the crankcase. Fill with recommended type oil as specified in the maintenance section of this manual
14. **Fuel Injection System** – **ALWAYS** keep dirt, dust, and any foreign debris from entering the fuel injection system. Clean the fuel injection system as recommended in the maintenance section of this manual.



Operating the engine without an air filter, with a damaged air filter, or a filter in need of replacement will allow dirt to enter the engine, causing rapid engine wear.

C-30HDNI (PRECISION) PUMP — GENERAL INFORMATION

The following operating principles and operating suggestions should prove helpful in the successful operation of your concrete pump. Your new "small line" concrete pump has been designed to give you many years of service when operated properly. A study of the following paragraphs is important to the successful operation of your new Direct-flow Concrete Placer.

All concrete pumps require a high level of operator skill and more frequent service than most of the other construction equipment. The highly abrasive nature of concrete under pressure makes it extremely important that expendable wear components be inspected at regular intervals between jobs to prevent having to replace these items during a pour.

Experience has proved that inconsistency of batched concrete mixes and frequent moving of the line requires the operator to be readily available at all times during pumping to stop the pump and prevent abuse to the unit which may occur if unexpected blockages develop.

Pump Mix Guidelines

When ordering concrete, be certain to advise the concrete supplier that you require a "**pump mix**". The Direct-flow manifold will pump a wide variety of materials, but certain basic principles must be followed to assure successful pumping, as follows:

Generally speaking, the washed concrete sand and #4 aggregate (pea gravel) should conform to A.S.T.M. standards in regard to sieve analysis. Sands in some areas are washed clean of the #100 and #200 mesh fines, which results in separation and jamming in the manifold while pumping under pressure.

If this condition develops, check with your concrete suppliers engineers and get their recommendations for supplementing the lack of the fines. The use of locally accepted ad-mixes may be required. (For example, Pozzoloth, Bentonite Clay, Plastiments, etc.) When properly prescribed, additives form the plastic paste sometimes necessary to hold the cement and aggregate together.

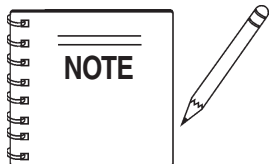

If jamming conditions in the pump or hose occur for any reason at all, do not attempt to use more power to correct the condition.

Determine the cause of jamming, correct it and resume pumping. Trying to force material through under jammed conditions may result in damage to the drive system, thus voiding any warranty services.

As a general rule, the use of approximately six sacks of cement, 70% washed concrete sand and 30% #4 pea gravel per yard of concrete will result in a pumpable mix. The ideal nature of sand and rock in certain areas may permit you to increase the percentage of rock or adjust the mix considerably to meet the job requirements. When possible, you may experiment with various mixes in your area to determine the degree of versatility of the Direct-flow Pump.

Uniform gradation of the washed concrete sand and the 1/2" minus aggregate along with sufficient cement content and water are important to a successful pump operation.

A recommended pumpable mix design would be 70% sand and 30% aggregate-cement content to be a minimum of 6 sacks. (564 lbs.)

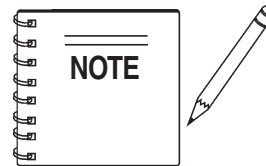

Your local sand and rock engineers will give you the S.S.D. weights of sand and rock required in your local area which will yield one cubic yard per the above recommendation.

Sample Design Mix - 3000 Psi 3/8 in. Slump 4- 5 in.

Type II Cement	6.49 sack/cu. yd	611 lbs.
Sand	Sat. Surf. Dry	2000 lbs.
#4 Gravel	Sat. Surf. Dry	864 lbs.
#3 Gravel	Sat. Surf. Dry	0 lbs.
Water	48 Gallons	400 lbs.
	Total Weight	3,906 lbs
Admixture WRDA-79		26 oz.
Water	7.40 gal/sack	

Test laboratory data has proven in many areas that the above mix guidelines have produced concrete rated at 3000 psi (28 day test) and upwards of 5000 psi with an increase in cement.

In some areas where the gradation of sand and rock is ideal and sufficient cement is used along with admixtures, the Mayco small line concrete pump will handle up to a 50-50 ratio of sand and rock.

When the mix is designed for wet gunning applications, it is normal to increase the cement (up to 7.5 or 8 sacks) and change the sand to rock ratio to 85% sand and 15% rock.

The Mayco concrete pump will valve efficiently when using cellular-foam concrete mixes upwards of 70 lbs. per cubic foot wet density. (Below 70 lbs. materials (roof decks) the valving becomes inefficient.)

C-30HDNI (PRECISION) PUMP — HOW IT WORKS

The C-30HDNI concrete pump has one main pumping piston which is valved by means of two ball checks. (**A** inlet, and **B** outlet.)

The secondary piston is used as a compensator piston to smooth out the pulsations of a single piston action. Note: The compensator will not start operating until material is pumped into the line and back pressure develops.

The **compensator spring**, which is installed on the compensator piston rod, deflects with each piston stroke. This “**spring cushion**”, in conjunction with the cam profile, produces an uninterrupted smooth flow of material under average pumping conditions.

The pumping cylinder (Figure 10) retracts drawing the material past the ball (**A**) and filling the cylinder. The compensator piston is pumping the material out to the nozzle and causing ball (**B**) to seat preventing the material from returning to the pumping cylinder intake.

An automatic, centrifugal clutch is installed to engage and disengage the pumping action without stopping or starting the engine. The **centrifugal clutch** is set at 1100 R.P.M. The engine idle speed is approximately 875 R.P.M.; therefore, the clutch is completely disengaged at idle. The throttle settings while pumping should always maintain an engine R.P.M. high enough to prevent the clutch from slipping and burning the clutch lining.

The return spring which is installed on the rocker arm, is installed to eliminate shock and stress between the cam roller and the cam weldment when the pump is in operation. If the return spring is removed or replaced for any reason, maintain the backing plate dimension of 3” as shown on Figure 3, to produce the proper pre-loading of the spring for a smooth performance.

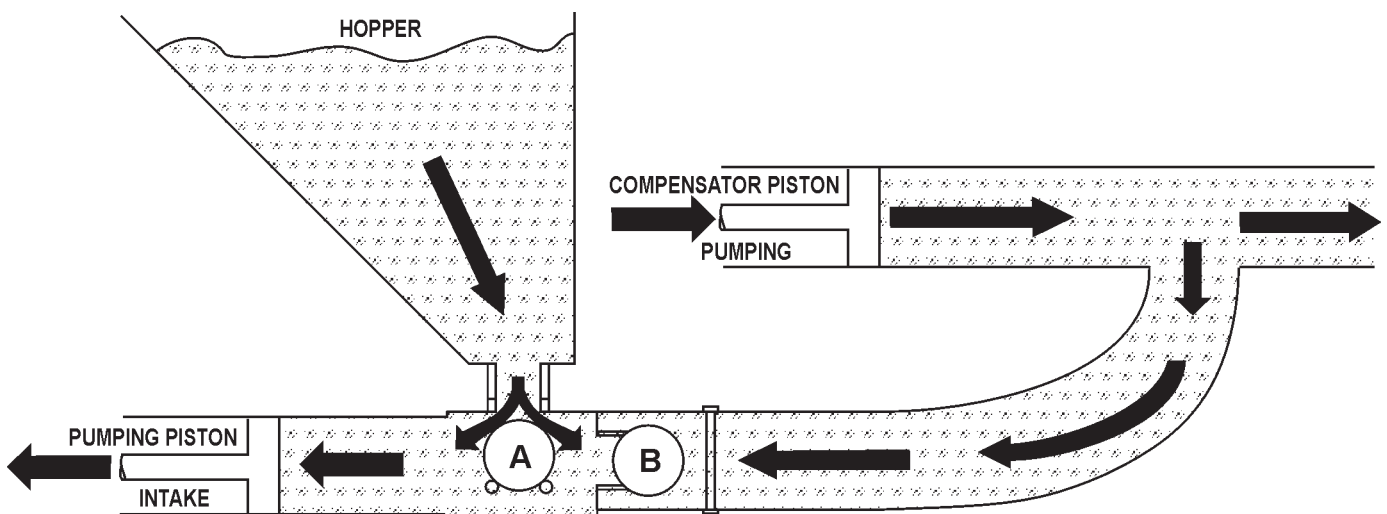

Figure 10. Pumping Cylinder

C-30HDNI (PRECISION) PUMP — HOW IT WORKS

The pumping piston (Figure 11) is forcing the material past ball (B) and out to the nozzle, also seating ball A so that the material will not flow back to the hopper. This action also fills the compensating piston for the next stroke.

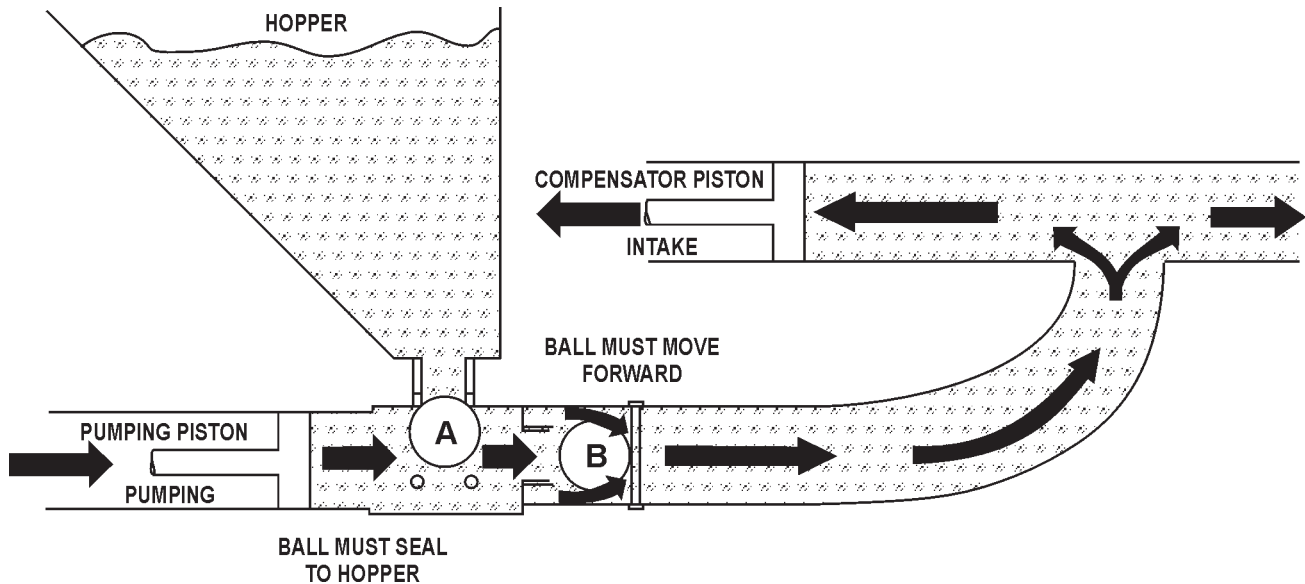

Figure 11. Pumping Pistons

Figure 12 shows the relationship between the return spring, the compensator spring and the rocker arm to maintain a smooth performance. **DO NOT** tighten the bolt (Item 1) completely, the rod end must be able to move.

The return spring is installed to eliminate shock and stress between the cam roller and the cam weldment when the pump is in operation. If the **return spring** is removed or replaced for any reason, maintain the backing plate dimension (3-inches) as shown to produce proper pre-loading of the spring for a smooth performance.

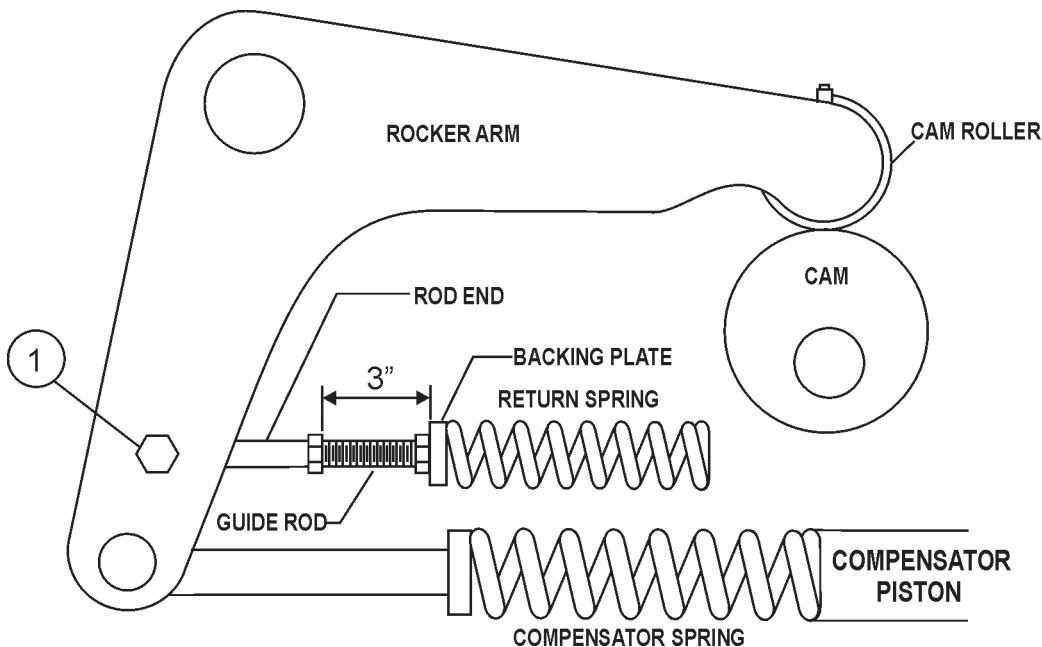
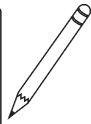
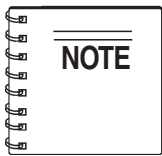

Figure 12. Return Spring, Compensator Spring and Rocker Arm Interaction

C-30HDNI (PRECISION) PUMP — OPERATING INFORMATION

OPERATING SUGGESTIONS

1. A well-planned location of the pump and routing of the hose before starting a pour may save subsequent moves throughout the job.
2. Before concrete is discharged into the hopper, it is suggested that 3 to 4 gallons of water be sprayed into the hopper, followed by approximately 5 gallons of a creamy cement and water slurry (1/2 bag of cement to 5 gallons of water). This procedure lubricates the hose and prevents separation and blockages in the hose.



Getting the concrete to flow through the hose at the start of the pumping cycle can be one of the most critical operations of the pour. (**Manually** operate the throttle when starting, **NOT remotely**)



WARNING - Hose Blockage Hazard

If hoses or lines are **blocked** for any reason, or if the lines are **kinked** when starting up or during the pumping cycle, the pump pressure could straighten out the kink or force out the blockage. This rapid surge of material could cause the lines to **whip** or **move** in a manner that could cause injury to personnel.

Inspect the lines at all times to prevent the above conditions

3. It is important that once the slurry procedure is completed, and you have started concrete flowing through the hose, do not stop the pour until all the slurry is pumped out and the concrete has reached the end of the hose. The only time to stop the pump at the start is if a blockage occurs.
4. When the pump is stopped for any reason during a pour; e.g., moving hose, waiting for redi-mix truck, the following suggestions are offered:
 - A. Leave the hopper full of concrete at the time of shutdown. It is important not to let the **redi-mix** driver wash too much water into the hopper, as this could cause separation of the concrete in the hopper.
 - B. If the **shutdown** period exceeds 2 to 3 minutes, turn off the engine so the vibration does not separate the mix in the hopper which can cause a blockage in the manifold when the pump is started.

- C. If it is necessary to wait 10 minutes or more for another load of concrete, it is wise to start the pump and pump 6 or 8 strokes every 5 minutes to prevent setting of the mix in the system. If waiting time is excessive, it would be wise to wash out the pump and hoses and start over when the new truck arrives.
- D. When pumping stiff mixes and there is waiting time between redi-mix trucks, it is advisable to add some water to the last hopper of material and “hand mix” to ensure an easier start with the following load.
- E. When the pumping job requires a stiffer mix, the following method is suggested for starting: Take a water hose with a nozzle on it and apply water with a fine spray to the concrete as it comes down the redi-mix chute into the pump hopper after the slurry procedure is completed and you are ready to start pumping.

Using this procedure will make it easier to pump through the clean hose. Note: Once the concrete has reached the end of the hose, do not apply any more water in this manner as this procedure is used on the start only.

- F. Hose sizing is very important: We strongly recommend on harsh mixes, vertical pushes, stiff concrete, shotcrete, long pushes, that a 2 -1/2” line be used as far as possible. The advantages of using the 2 -1/2” line are improved pumpability, less pumping pressure and less wear on the pump.
5. Following the pump operation, proper wash out of all materials or “build-up” within the pump manifold and hoses will prevent problems when starting the next job.
6. A thorough inspection of the drive components and greasing of all bearings after each job will ensure adequate lubrication and service to the pump which is normally operating in wet, gritty conditions.

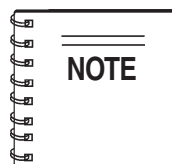

Over-greasing any **bearing** on your Mayco pump will not damage the bearing.

C-30HDNI (PRECISION) PUMP — OPERATING INFORMATION

WARNING - Hose Blockage Hazard

If you repeatedly pull the throttle all the way out and try to force your pump to push through **blockages** due to separation of material in the hose or manifold, you will soon have breakdowns and costly repairs which are not covered under warranty.

If a blockage occurs, find where it is and clear it before further pumping. **DO NOT** increase the engine speed to clear the blockage. Increasing the engine speed will only compound the problem.

WARNING - Moving The Pump On The Job Site

It will be necessary at times to move your pump from one job site location to another. Before moving the pump, make sure to pump the remaining concrete out of the hopper. Moving the pump with a **full hopper** of concrete can cause severe damage or breakage of the axle and axle springs, excess strain and pressure on the hub and bearing assembly.

New Pumps

All new pumps are “**water pressure tested**” at the factory before shipment. This procedure permits a thorough inspection of the entire drive system and valving under simulated full load conditions.

The pump owner can do the same by attaching an adaptor couple to the end of the discharge cone; e.g., the use of a standard 2 in. pipe cap with a 3/8 in. hole drilled in the center, screwed on to the end of the hinged cone or reducer at the pump.

Fill the hopper with water after making sure that all sand and rock have been removed from the manifold. Operate the pump at full throttle and the 3/8 in. diameter hole restriction will create sufficient back-pressure to make a thorough inspection of all moving parts.

Pumping Tips

1. **The effects of heat and excessive time on concrete:** Hot concrete, commonly referred to as a hot load, is concrete that has been in the redi-mix truck in excess of 2 to 3 hours. On a hot day, this amount of time is even less. A brief explanation of why heat and time affect concrete:

Concrete starts setting by drying up through a chemical reaction. The catalyst to this reaction is heat. When pumping a hot load, it is important to remember that when you have to stop pumping for any reason, add water to the concrete in the hopper and hand mix and move concrete in the hose every 5 minutes. If the shut down time becomes too long, wash out immediately.

2. ADMIXTURES

Remixtures that are designed into the concrete mix by the redi-mix company or an architectural engineering company. This section lists common admixtures and a brief explanation of their functions:

- A. **Pozzolith 300** – or the equivalent acts as a water retarder and a lubricant. On a lean mix, long pushes, stiff mixes, and vertical pushes, Pozzolith 300R helps pumpability.
- B. **MBVR** – air entraining, acts as a lubricant.
- C. **Calcium Chloride** – commonly referred to as C.C., is used as an accelerator. When pumping a load with calcium chloride, it is recommended that you wash out if the waiting time between delivery trucks becomes too long.
- D. **Super Plasticizers** – acts as an accelerator. The concrete will look very wet after the super plasticizer is added, but will begin to set up very fast. Wash out immediately if you do not have a truck waiting. Super plasticizers are used mainly on commercial jobs.
- E. **Red Label** – acts as a water retarder and an accelerator. Red label will be used mainly on commercial jobs.
- F. **Fly Ash** – is used to help increase the strength of the concrete and decrease the cement content per yard. This is one of the most common admixtures used.

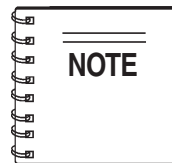

All admixtures will be shown on the redi-mix concrete ticket. Before starting the pumping job, ask the driver of the redi-mix truck to see the concrete ticket and note the admixtures that exist and take the proper action.

- 3. When pumping long distance or pumping stiff mixes, you can expect a drop in volume compared to shorter lines and wetter mixes due to the change in valve efficiency or cavitation.
- 4. Leaking manifold seals or hose coupling gaskets which leak water can cause separation and subsequent jamming at that point.
- 5. Damaged hoses with internal restrictions can cause blockages.

C-30HDNI (PRECISION) PUMP — OPERATING INFORMATION

6. If a blockage occurs in a hose, “walk the hose” until you find the point of trouble. The hose will be soft immediately past the blockage. If this happens at the start, disconnect the hose at the first coupling past the blockage.

Elevate the hose at that point with the blockage area hanging down.

CAUTION - Hose Pressure Hazard

When disconnecting hoses, use **extreme CAUTION!** The hose is under pressure!

Using a hammer, you can pound the down-stream edge of the packed area until it is free to flow. Shake all of the sand and gravel out to the end of the hose. Before reconnecting the hose, start the pump and run a small amount of concrete out to the end of the hose. This will assure that all of the separation is out of the hose.

7. Clearing a Plugged Manifold

The manifold is plugged if the volume at the discharge end of the hose stops, and the hose is soft. The drive belts will start to slip and the engine will lugdown.

Follow steps 7A through 7J to un-plug a clogged manifold.

DANGER - Clearing A Plugged Manifold

Due to pressure build-up inside the manifold, great care must be taken when clearing a plugged manifold.

- A. **STOP** the pump. Switch **OFF** the engine.
- B. **DO NOT** open any of the delivery system joint clamps.
- C. The **senior** operator must warn all others to stand at least 20 feet away from the pump and turn their heads away from the manifold.
- D. The operator must position himself/herself away from the hinged side of the manifold.
- E. Wearing safety glasses, grasp the clamp arm weldment and carefully pull it open to the primary (safety) position. **STOP** count to 20. This will allow the pressure to release.
- F. After the pressure has been released, open the clamp arm weldment and swing the hinged discharge cone open.
- G. Remove blockage with a round 2-foot length of reinforcing steel rod. Flush the manifolds with water. Make sure the (3” x 2”) reducer is clear of any blockage before closing the discharge cone.

- H. After the blockage has been cleared and the pump manifold has been thoroughly flushed with water, close the hinged discharged cone and lock into place.

- I. Before reconnecting hose to the reducer, start the engine and pump two or three shovels of concrete through the reducer. This will insure that all the blockage has been cleared.

- J. Shake out around 2 feet of concrete before reconnecting hose to pump. After this is done, connect hose to pump and resume the pumping operation.

8. Avoiding Setting of the Mix in the System

To avoid setting of the concrete mix in the system when waiting more than 30 minutes between concrete loads, flush the system depending on job factors (such as presence of accelerators and job site temperature) and your particular mix design.

Clearing a Mix from the System

If, for any reason, the mix should set up in the system, the following procedure is suggested:

CAUTION - Hose Pressure Hazard

When disconnecting hoses, use **EXTREME CAUTION!** The hose is under pressure!

1. Disconnect the hoses from the pump and wash the pump out immediately. For example: If you had 200 ft. of system out, you would disconnect each hose.
2. Reconnect the first hose and fill the hopper with water. **DO NOT** try to push all the concrete out of all of the hose lines at one time.
3. Clean it out by pushing water through the first hose off the pump, then continue progressing through all the hoses, until all the system is clean.
4. If waiting time is excessive, it would be wise to wash out the pump and hoses and start over when the new truck arrives. This can be avoided by being observant to the pump and system, also taking into consideration the above factors affecting the mix.

C-30HDNI (PRECISION) PUMP — OPERATING INFORMATION

Down-Hill Pumping

Downhill pumping can be difficult on some jobs. It is suggested that a sponge 2"x 4"x 6" be placed in the hose before the start of pumping. Wet the sponge before placing it in the hose. Reference the Operating Suggestions at the start of this section for slurry procedures.

The reason for using the wet sponge is to keep the slurry from running too far ahead of the concrete and so reducing the possibility of separation. When the pump is stopped, the material can flow slowly down, due to gravity, and cause the hose to collapse.

When pumping is resumed, you can expect a blockage at the point of hose collapse. To prevent this from happening, the hose can be "kinked off" at the discharge end when the pump is stopped to prevent the gravity flow of the material in the hose.

The use of stiffer mixes when pumping down-hill will decrease gravity flow of the material in the hose and will assure a smoother operation between the cam roller bearing and cam plate. As with any job, make sure that the hose and the couplings are in good workable shape.

Vertical Pumping

When pumping vertically up the side of a building, above 40 feet, we would recommend the installation of **steel pipe** securely fastened at intervals as necessary to support the pipe. Ninety degree, long radius pipe sweeps should be installed at the top and bottom of the steel line.

Use a 25 ft. hose, or short section, off the pump; and for the balance of the horizontal distance to the vertical line, use steel pipe. This type of installation has been satisfactory on many jobs being pumped in excess of 100 feet high. Line pressures are always less using steel pipe as compared to hose.

When pumping vertically using **all hose**, it is recommended not to go higher than 50 feet with hose. The hose should be tied off at intervals of 10 feet, if possible. Special attention should be given when tying the hose off at the top as the hose will have a tendency to stretch when filled with concrete. This will increase the possibility of a blockage at the point where the hose is tied off. To avoid this, a long radius of 90 degree elbow is recommended. The suggested place to tie off is on the hose, under the clamp.

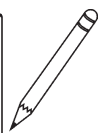
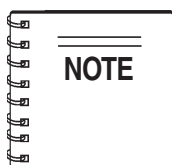

It is strongly recommended that steel pipe be used on **ALL** vertical pumping for safety and convenience.

Valve Seats

If the volume at the end of hose starts to decrease gradually and eventually almost stops, it is quite likely that the **valve seats** have had excessive wear and need replacement. Once they have reached a certain wear point, they may "channel out" rapidly and material will reciprocate past the ball on each stroke.

The hollow **steel ball** should be replaced when it starts to show dents or appears to be badly worn. Sand and aggregate materials in some areas are extremely sharp and hard and therefore highly abrasive. Under these conditions when pumping stiff mixes, or to high elevations which cause line pressures, it will be noted that valve components may have short wear life.

If this condition exists, it is advisable to remove the manifold only, and inspect the lower seat at the end of each day. If it appears that the seat is beginning to "channel out", replace before starting the next day's pour.

The upper valve seat can be inspected after each washout by running your finger around lower edge of seat where the ball makes contact. You can reach this from the inside of the hopper. Be sure that the engine is turned off.

Pulsation

A slight pulsation of the hose will always be noticeable near the pump. Excessive pulsation of the hose near the pump is normally due to higher than average line pressures caused by stiff, harsh mixes, or extremely long pumping distances.

The use of 2 - 1/2" I.D. hose in these extreme cases reduces line pressures or the addition of slight amounts of water to the mix, if permissible, will permit easier pumping. The use of certain pumping admixtures may help.

If excessive pulsation exists in the hose, it is advisable to use burlap or some means of wear protection under the hose at points where the hose may wear through the outer cover; e.g. over forms, steel or sharp curbs.

C-30HDNI (PRECISION) PUMP — OPERATING INFORMATION

Cam Roller

If the cam roller does not ride on the cam profile smoothly, it may be caused by insufficient line back-pressure; e.g., a wet mix with only 50 feet of hose. Add more hose as necessary. It can also be caused by cavitation or the passing of over-sized aggregates through the valving, causing it to skip.

Snap-Joint

When using Snap-Joint couplings with gaskets to join hose, see that they are washed clean after each job. Keeping the hose ends clean (heavy duty) is very important for the best job setup. A thin coat of grease on the rubber gasket or dipping both coupling and gasket in water before coupling the hose will make for easier installation.

C-30HDNI (PRECISION) PUMP — INSPECTION

CAUTION - General Safety Guidelines

NEVER operate the pump in a confined area or enclosed area structure that does not provide ample **free flow of air**.



ALWAYS wear approved **eye** and **hearing** protection before operating the pump.

NEVER operate the pump's engine with the engine hood removed. The possibility exists of **hands**, **long hair**, and **clothing** becoming entangled with the V-belt, causing injury and bodily harm.



NEVER place hands or feet inside the **hopper**. **ALWAYS** make while the engine is running. **ALWAYS** shut-down the engine before performing any kind of maintenance service on the pump.

Before Starting

1. Read safety instructions at the beginning of this manual.
2. Removing any dirt and dust that might have accumulated around the engine cooling air inlet, fuel injection system.
3. Check the air filter for dirt and dust. If air filter is dirty, replace air filter with a new one as required.
4. Check fuel injection system for external dirt and dust. Clean with dry compressed air.
5. Check fastening nuts and bolts for tightness.
6. Connect Battery
7. Make sure hopper is free of dirt and foreign debris (large objects over 2-inches)
8. Make sure radiator is filled with proper amount of anti-freeze water solution (50/50).
9. Make sure all hose lines are in good condition and are working properly.

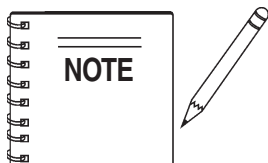

Reference manufacturer engine manual for specific servicing instructions.

Engine Oil Check

1. To check the engine oil level, place the pump on secure level ground with the engine stopped.
2. Remove the dipstick from its holder (Figure 13) and wipe it clean.

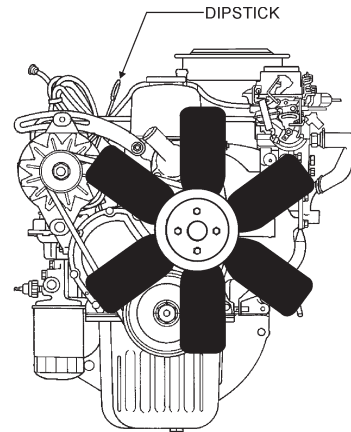

Figure 13. Engine Oil Dipstick (Removal)

3. Check the engine oil level as shown on the dipstick (Figure 14).

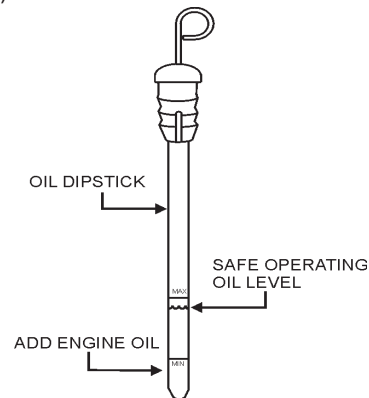

Figure 14. Engine Oil Dipstick

4. If the engine oil level is low, add oil through the engine oil filler hole (Figure 15) with the recommended oil type (Table 3). Maximum oil capacity is 3-3/8 quarts (3.2 liters).

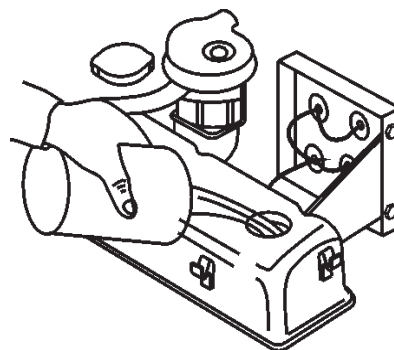

Figure 15. Engine Oil Filler Hole

C-30HDNI (PRECISION) PUMP — INSPECTION

TABLE 5. OIL TYPE

Season	Temperature	Oil Type
Summer	25°C and greater	SAE 10W-30
Spring/Fall	10°C to 25°C	SAE 10W-30/20
Winter	0°C or Lower	SAE 10W-10

Gasoline Check

1. Remove the gasoline cap located on top of fuel tank.
2. Handle Fuel in a safety container. If the container does not have a spout use a funnel.
3. Visually inspect to see if fuel level is low. If fuel is low, replenish with unleaded fuel. When refueling, be sure to use a strainer for filtration. **DO NOT** top-off fuel. Wipe up any spilled fuel.
4. Pay attention to the fuel tank capacity when replenishing fuel. Refer to the fuel tank capacity listed in Table 5.

! WARNING - EXPLOSIVE FUEL



Gasoline is extremely flammable, and its vapors can cause an explosion if ignited. **DO NOT** start the engine near spilled fuel or combustible fluids. **DO NOT** fill the fuel tank while the engine is running or hot.

DO NOT overfill tank, since spilled fuel could ignite if it comes into contact with hot engine parts or sparks from the ignition system. Store fuel in approved containers, in well-ventilated areas and away from sparks and flames. **NEVER** use fuel as a cleaning agent.

DO NOT smoke while refueling, motor fuels are highly flammable and can be dangerous if mishandled.

Lubrication Box

The model C-30HDNI model features a fully enclosed **lubrication box**, which utilizes the "**SPLASH**" method of lubrication.

Before using your new pump, 7 gallons of SAE 30 motor oil must be added directly into the lubrication box. Visually inspect the oil in the lubrication box by making sure the oil is at the correct operating level as indicated by the dip stick (Figure 16).

Also reference the oil level decal (Figure 17) adjacent to the lubrication box.

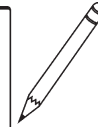
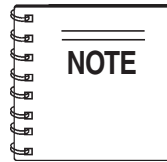

Make sure the pump is on a secure level surface when checking the oil level inside the lubrication box.

! CAUTION - Checking Lubrication Oil Levels

The oil level **must** be **checked daily** to ensure adequate oil level and oil cleanliness.

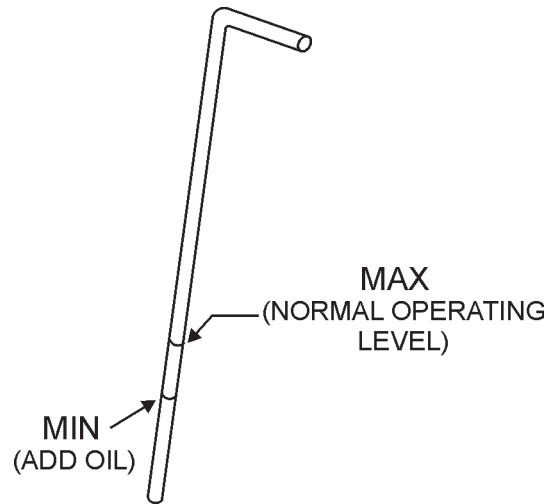

Figure 16. Lubrication Box Dipstick

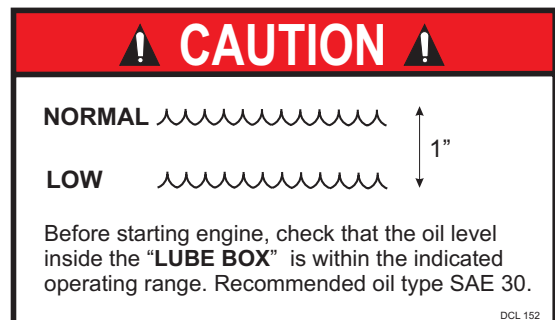

Figure 17. Lubrication Box Oil Caution Decal

C-30HDNI (PRECISION) PUMP — INSPECTION

Checking Engine Coolant Level

1. Remove the radiator cap, and check the cooling water level inside the radiator (Figure 18).
2. Maintain water/coolant level at top of radiator coils.

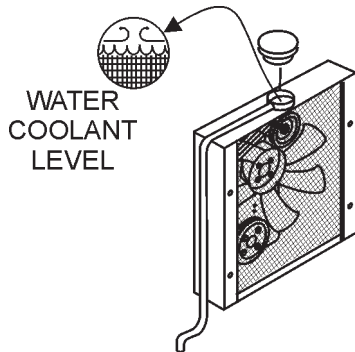

Figure 18. Radiator Coolant

WARNING - Burn Hazards

NEVER remove the radiator cap when the engine is **HOT!** Allow the engine to cool before remove the cap.



3. Check the radiator and hoses for any signs of leakage.
4. If cooling water is dirty, flush the cooling system.
5. When using antifreeze, mix the antifreeze coolant with water. Observe the instructions on the antifreeze container. Usually a 50/50 mixture is a good choice.
6. When replacing the radiator cap, be sure to fit it securely back onto the radiator. (If replaced loosely or incorrectly, the cooling water will quickly evaporate, causing the engine to overheat.)

V-Belt Deflection

1. Visually inspect the V-belt for cracks, fraying, wear or oiliness.
2. Make sure V-belt does not the bottom the pulley groove.
3. Check the V-belt tension (Figure 19) by pushing midway through the two pulleys. The V-belt deflection should be between .300 to .472 inches (8 to 12 mm).

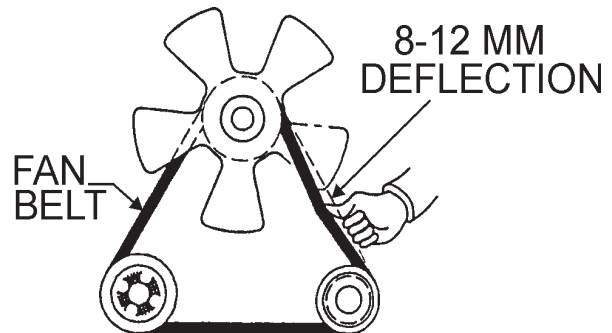

Figure 19. V-Belt Deflection

C-30HDNI (PRECISION) PUMP — STARTUP/SHUTDOWN PROCEDURES

Starting

CAUTION - General Safety

DO NOT attempt to operate this concrete pump until the Safety, General Information and Inspection sections have been read and understood.

1. Turn the throttle control knob fully counter-clockwise to set the engine speed to **IDLE**. (Figure 17.)

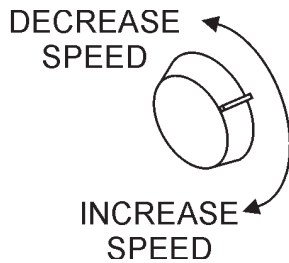
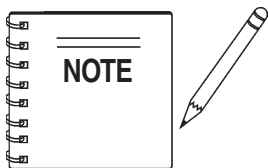

Figure 20. Throttle Control Switch



During **pumping operations**, the engine speed cannot be reduced below **1300 RPM's**.

This built in feature protects the clutch from disengaging (slipping) during operation.

2. Place the pumping control switch (Figure 21) in the **OFF** position.

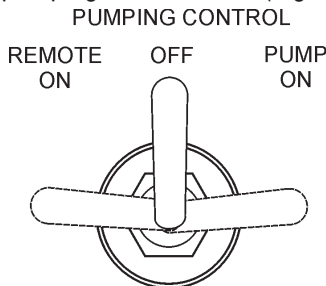

Figure 21. Pumping Control Switch (OFF)

3. Insert the ignition key into the ignition switch (Figure 22), turn the key to the **ON** position, then to the **START** position, release the key when the engine starts.

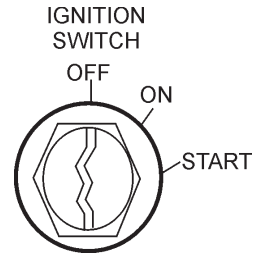

Figure 22. Ignition Switch

6. Verify that the **oil pressure**, **battery** and **water temperature** status lamps (Figure 23) are all **OFF**. If any of these lamps are **ON**, stop the engine and correct the problem.

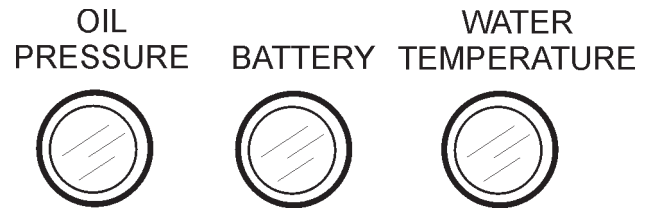

Figure 23. Control Box Status Lamps

7. Let the engine run for 3-5 minutes before putting pump into operational use. Push the choke knob in all the way.
8. Listen for any abnormal sounds. If any mechanical or electrical problems exists, **STOP** the engine and correct the problem.
9. To begin pumping concrete. Place the pumping control switch (Figure 24) in the **ON** position

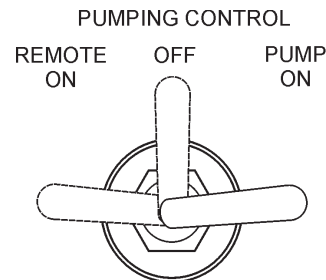

Figure 24. Pumping Control Switch (ON)

System Shut-Down

1. Place the pumping control switch in the **OFF** position (Figure 21).
2. Turn the throttle control knob fully counter-clockwise. Let the engine run at idle speed for 3-5 minutes.
3. Turn the ignition key (Figure 22) to the **OFF** position.
4. Clean pump as referenced in the maintenance section of this manual.

C-30HDNI (PRECISION) PUMP — MAINTENANCE (PUMP)

Preventive Maintenance

It is extremely important to maintain this pump due to the highly abrasive nature of concrete material.

1. Inspect all drive components for loose or worn bolts.
2. Drive belt/chain should be checked to remove all slack. Refer to adjustment procedure.
3. **ALWAYS** carry extra “O” rings.
4. Keep entire pump clean of concrete to prevent build-up.
5. **ALWAYS** grease every fitting daily. Use only premium grade grease.

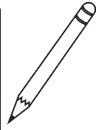
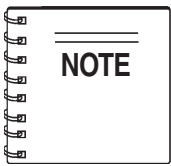

Over greasing will not damage pump.

General Clean-up Procedure

1. Ensure that there is no blockage in the hose and line (Pumping Tips, step 8) or in the manifold (Pumping Tips, step 7). If a blockage exists, clear it to ensure proper operation the next time it is used. At the end of every pour, or during long delays during a pour, the pump and delivery system must be thoroughly cleaned by removing all concrete material.
2. Proper wash out of all materials or build up within the pump manifold and hoses following the pumping operation will prevent problems when starting the next job. After completion of the pour, pump the remaining concrete in the hopper through the discharge line.

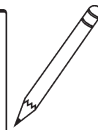
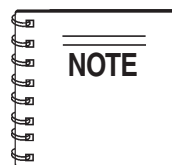

To avoid the possibility of separation during clean-up, do not pump the concrete below the inlet ball in the hopper. It is best to leave approximately 3 to 4 inches of concrete above the inlet ball.

3. Turn the pump engine off before filling the hopper with water. Engine vibration at idle may “separate” material in the hopper, causing jamming in manifold when pumping is resumed.
4. Fill hopper with water and resume pumping. The water will push the concrete through the line. When the water runs clear at the end of the hose, disconnect lines and shake out all the sand and sediment so the lines will be clean for the next pour.
5. It is important that the hinged discharge cone on the pump manifold be opened and all remaining concrete (rock and sand) be thoroughly washed out. This must be done after each job to prevent concrete build up in the discharge manifolds and 3” discharge elbow.

C-30HDNI (PRECISION) PUMP — MAINTENANCE (PUMP)

Sponge Clean-out Procedure

This section will explain the recommended procedure for using a *sponge* to clean out the *hose lines*.

CAUTION - Clearing The Pump

NEVER use *muriatic acid* to clear the pump. Acid will dissolve the chrome finish on the pumping cylinder.

NEVER use compressed air to clean out the lines.

When using a clean-out hook to clean out the rear of the redi-mix truck, use a *safety chain* to secure the clean-out hook to some solid part of the redi-mix truck to prevent the hook from jumping off the redi-mix truck's hopper. Run the pump at half throttle.

1. After completion of the pour, pump the remaining concrete in the hopper through the discharge line. Using a shovel, clean the sides of the hopper.

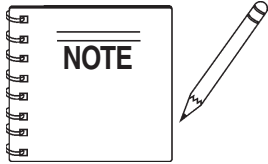

The pump engine should be turned **OFF**, as explained in General Clean Up Procedure.

After the sides of the hopper have been cleaned, add a small amount of water to the remaining concrete in the hopper and hand mix.

2. Start the pump engine and pump the hopper all the way down.
3. Disconnect the hose from the pump. Fill the hopper with water and pump the remaining concrete out of the pump.
4. Open the hinged discharge cone and thoroughly wash out all remaining concrete (sand-sediment) from the cone and pump manifolds. Close the discharge cone and lock in place.
5. Take a sponge (2"x4"x6") and soak it with water. Take the hose that is disconnected from the pump and shake out the concrete so that about 2 feet of it is clear. Insert the sponge into the hose.
6. Reconnect the hose to the pump. Fill the hopper with water and resume pumping. Run the pump approximately half throttle. The sponge will be discharged at the end of the line followed by clear water. At this point, the pump and lines will be completely clean and ready for the next job.

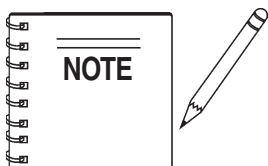

Repeat steps 1 through 6 a few times to ensure that the hose lines are thoroughly cleaned.

Lubrication Box

The C-30HDNI model features a fully enclosed *lubrication box*, which utilizes the "*SPLASH*" method of lubrication.

Visually inspect the oil in the lubrication box (Figure 16) by making sure the oil is at the correct operating level as indicated by the dip stick. Also reference the oil level decal (Figure 17) adjacent to the lubrication box.

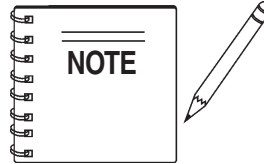

Make sure the pump is on a secure level surface when checking the oil level inside the lubrication box.

CAUTION - Checking Lubrication Oil Levels

The oil level **must** be *checked daily* to ensure adequate oil level and oil cleanliness.

Piston Cup Wear

The *rubber piston cups* are a *natural wear* component and **will require** periodic replacement. The life of the rubber cups depends on many factors, proper oil level, oil cleanliness, abrasiveness of aggregate being pumped and material slump etc.

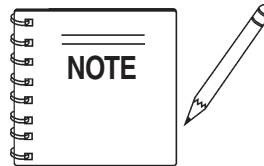

IMPORTANT! To ensure maximum cup life, the oil level in the lubrication box **must be** maintained at the proper level. In addition the lubrication box must be cleaned periodically.

As the rubber piston cups wear, fine cement particles will accumulate in the bottom of the lubrication box. Once this cement paste reaches 1-inch in height, it is recommended that the lubrication box be drained (flushed) and cleaned and the oil replaced with new SAE 30 motor oil.

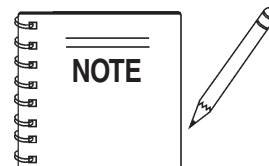

There are two clean-out ports located at the bottom of the lubrication box.

Any questions regarding the lubrication box clean-out procedure, contact the MAYCO Service Department.

C-30HDNI (PRECISION) PUMP — MAINTENANCE (PUMP)

Crankshaft and Cam Assembly Procedure

1. Set bearing block (P/N EM14303) into hydraulic press. Place bearing cup into bearing block and press in evenly. Bearing cup should be aligned equally on both sides of bearing block.
2. Set **crankshaft** into hydraulic press with the long end towards the top. Install spacer (P/N EM14322), O-ring (P/N EM14326) and bearing cone (P/N EM14325) onto crankshaft. Place bearing block on crankshaft until the bearing cone is riding in the bearing cup.
3. Insert bearing cone spacer (P/N EM14323) onto crankshaft and inside bearing block. Install second bearing cone until it is seated inside bearing cup.
4. Place O-ring and spacer (P/N EM14302) on crankshaft. Set cam weldment on top of spacer. Install crankshaft key and cam key on cam bushing (P/N EM14301).
5. Slide cam bushing down crankshaft and align the bushing, cam and crankshaft. Install sleeve over crankshaft and align with hydraulic press. Install cam bushing bolts loosely. Press bushing down onto bearing assembly. Leaving pressure on the bushing, tighten cam bolts evenly to 40-50 foot pounds.
6. Release pressure on the bushing, reapply pressure to bushing and tighten bolts evenly to 40-50 foot pounds. Repeat procedure 3 to 4 times.
7. After bushing has been fitted tightly into cam, remove from hydraulic press. Remove one bolt at a time, using Loctite, install bolts and torque to 65-70 foot pounds. Counter sink set screw hole and install dog point set screw and second set screw both with Loctite™.
8. Place cam bearing onto crankshaft keeping bearing loose.

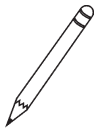
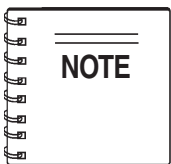

Make sure the eccentric lock is facing toward the outside of the pumping unit.

9. Set crankshaft assembly into the pump box and align both bearing assemblies with the pump box mountings.
10. After crankshaft assembly is securely fastened to the pump box, place sprocket (P/N EM14307) onto the cam side of the crankshaft assembly. Install bushing (P/N EM14309) into sprocket. Align sprocket with sprocket on countershafts and tighten bolts.
11. Install chain P/N EM14308. To adjust, loosen locknuts on pusher bolts and tighten chain to approximately 1/2 in. slack in the chain. Once chain is adjusted properly, tighten down locknuts.

Ball and Seat Replacement Procedure

1. Remove 3"x 2" reducer and 3" elbow from the pump outlet. Remove exhaust gate and Y-manifold (secondary manifold). Check ball seat and ball stop pin for wear. If any wear is detected, the part should be replaced. Remove T-manifold (primary manifold). Check all parts for wear. Remove hopper and hopper seat and inspect.
2. Loosen the piston nuts and remove the piston cup assembly and cylinders. Inspect all parts for wear and replace parts with excessive wear. Check oiler pump for proper operation.
3. Clean all parts thoroughly, removing all foreign material and concrete slurry. Once parts are clean, install concrete cylinders. Place oiler plate O-ring in place and coat with oil. Install small O-ring on piston rod. Run oiler line through the cylinders and connect in the oiler fitting on the oiler plate.
4. Push oiler plate into cylinder. Install ring and felt holder, soak felt ring in oil, then install around felt holder in cylinder. Make sure the bronze ring is flat, then push it up flush with the ring and felt holder.
5. Coat piston cup with oil and push it into the cylinder. Install bushing into center of piston cup. Put small O-ring on rod, place face plate on rod and tighten down securely. Repeat these procedure on the opposite cylinder.
6. Thoroughly check T-manifold, ball stoppings and both steel balls for wear. Insert an O-ring in the top flange and in the leading edge of the manifold. Put the manifold onto the primary side of the pump and install bolts leaving them loose.
7. Check Y-manifold for wear, install all O-rings, ball stop pin, ball and seat. Align and install Y-manifold to T-manifold and cylinder assembly. Tighten Y-manifold bolts first before tightening T-manifold bolts. After manifolds are tight, check O-rings for slippage.
8. Insert seat into frame hole directly above the T-manifold. The seat orifice should fit inside the frame itself, then the seat sits on top of the orifice. On the dura-seat, set the big end of the seat in the frame. The seat, or the small part of the dura-seat, fits into the bottom of the hopper.
9. After tightening the manifold bolts and inserting the seats in place, set the hopper over the seat and align the bolt holes. Tighten bolts, check O-ring and seat for alignment.
10. Check exhaust gate for wear, install and align gate onto Y-manifold. Insert O-ring into exhaust gate flange and close gate. Lock down lever and adjust clamp arm.
11. Install 3 in. elbow and 3x 2 in. reducer. Fill hopper half full and check for leaks.

C-30HDNI (PRECISION) PUMP — MAINTENANCE (PUMP)

Clutch Lining Replacement (For P/N EM14320 Clutch Assembly Only)

The normal lining thickness measures $\frac{3}{16}$ of an inch. If the clutch starts to slip or make an usual noise, it may be necessary to replace the lining. Please note that the lining retaining rivets **should not be exposed** to the rotating weight.

The following procedure will assist you in replacing the lining.

1. Remove worn out lining and rivets. Check clutch springs and flyweights for wear.
2. Cut $\frac{1}{8}$ in. off of each end of clutch lining. Slide lining into place. Insert one rivet into clutch lining hole. (Make sure rivet goes from inside out.) Wedge a flathead screwdriver between clutch flyweight and rivet head.
3. Adjust screwdriver so that the rivet sticks out from the clutch housing approximately $\frac{1}{8}$ of an inch. With a flat punch, pen the ends on the rivet so that it locks in place with the clutch housing. Repeat this procedure for all remaining clutch rivets.

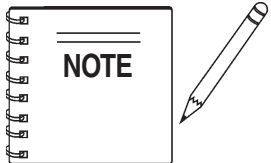

The clutch lining is a normal maintenance item and will require periodic replacement.

C-30HDNI (PRECISION) PUMP — MAINTENANCE (PUMP)

Bearing Installation

1. Install the bearing components on the crankshaft making full contact with the back side of the crank disc as indicated the symbol #. See Figure 25 below.
2. Install the bushing in the cam weldment and slide it onto the crankshaft until contact is made with the bearing spacer.
3. Tighten the 3 **allen head bolts** "A" while exerting pressure on the bushing towards the bearing spacer.

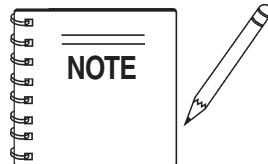

It is important that the **Bearing Assembly** is installed properly.

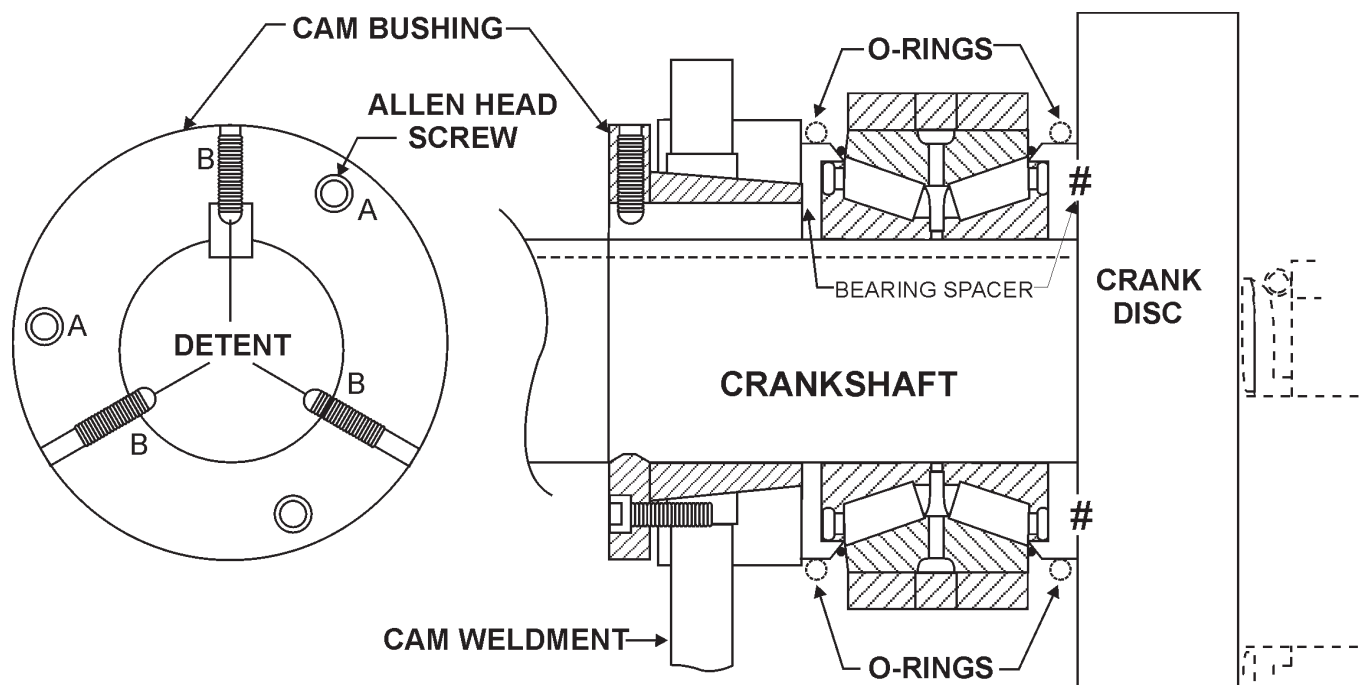
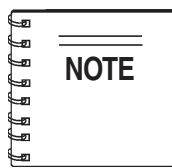

Figure 25. Bearing/Cam Bushing Installation

C-30HDNI (PRECISION) PUMP — MAINTENANCE (PUMP)

Detent Hole (3) Installation

1. After the bearing assembly has been installed, remove the three “dog type” allen head set screws (B) to allow detents to be drilled. See Figure 26 below.



The detent holes will prevent the bushing from sliding away from the bearing spacer when the pump is under load.

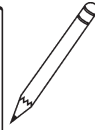
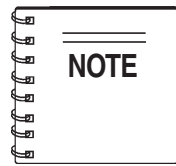

Position the ‘O’ ring on the O.D. of the bearing spacer during assembly to assure proper bearing adjustment.

2. Use a 9/32” drill to “detent” half (minimum 1/8” deep). Then “chase” the threads with a 3/8-16 bottom tap and blow out the chips after drilling, to be certain that the “dog type” allen set screws bottom in the detents to prevent the taper bushing from sliding laterally.
3. If this procedure is not followed closely the heavy loading of the bearing during pumping operation causes the Timken™ cone bearings to create lateral forces which will move the taper bushing and allow the Timken™ cone bearings to separate from the race and subsequently fail.
4. Drill (detent) the shaft under the allen set screws “B” to prevent the bushing from the sliding away from the bearing spacer when the pump is under a load.

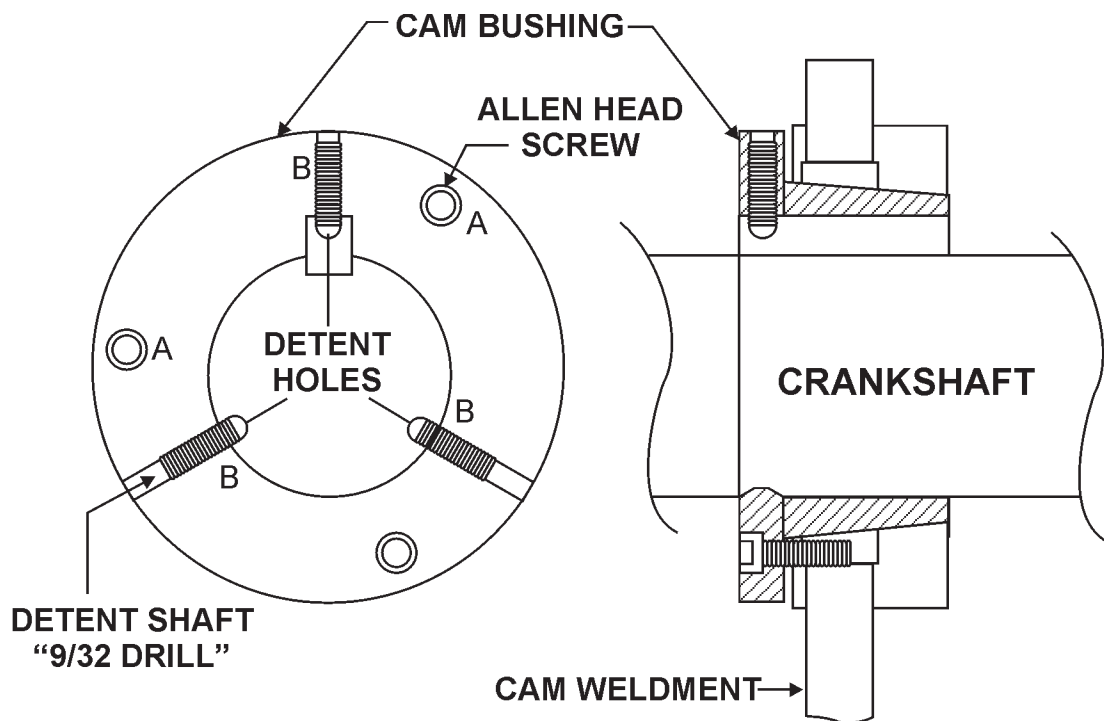

Figure 26. Detent Holes

C-30HDNI (PRECISION) PUMP — MAINTENANCE (PUMP)

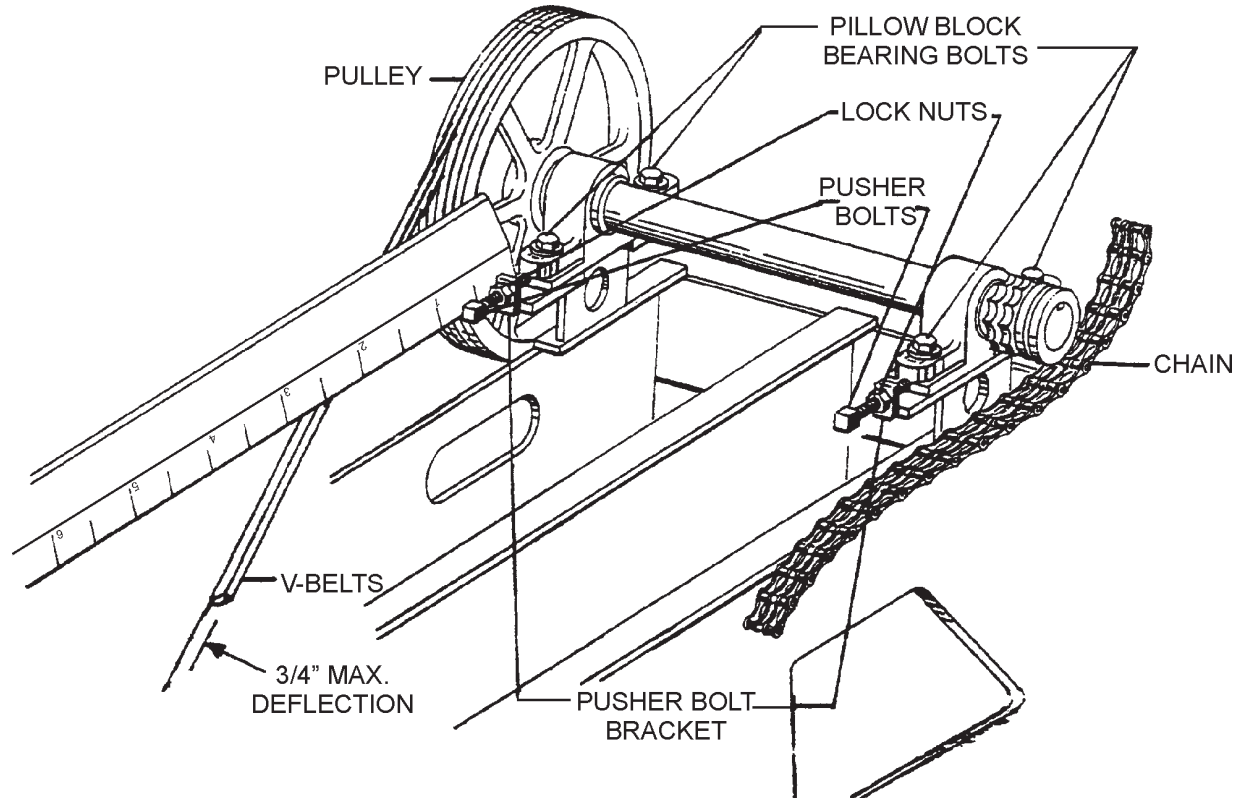
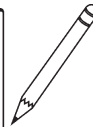
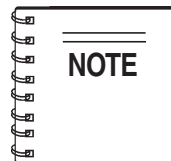

Figure 27. V-Belt and Drive Chain Adjustment

V-Belt And Drive Chain Adjustment

1. Loosen the pillow bearing bolts (Figure 27) only to the point where the bolts will remain snug.
2. Unlock the two pusher bolt lock nuts.
3. Turn each pusher bolt clockwise an equal amount until the chain is to proper adjustment of approximately 3/8 to 1/2 in. slack in the chain. It is very important that the pulley side and the chain side (pillow block bearings) are within 1/16" of an equal distance.
4. This distance can be checked by using a tape measure or a straight edge ruler, measuring from the inside of the pusher bolt bracket to the face of the pillow block bearing.
5. The drive chain should be adjusted regularly to remove all slack. Once all slack is removed, **DO NOT** over-adjust, as this will overload the shaft bearings. A slack chain on the crank drive creates backlash and shock loads on the shafts and bearings which results in shorter wear/life of the drive components.
6. Lubricate the chain regularly. Note-it is advisable to carry a spare chain and master links for replacement in the field if necessary.
7. Drive belts should be regularly adjusted to prevent slippage. To adjust the belts, loosen the engine mounting bolts and move the engine until there is a maximum 3/4 in. deflection in the belts, retighten the engine mounting bolts.
8. Frequent inspections should be made on all drive components to make certain that all bolts and nuts remain tight.



Prior to adjusting the chain, place the lobe of the cam in the down position. The chain should have 83 rivets, Including one each, half-link and full link.

C-30HDNI (PRECISION) PUMP — MAINTENANCE (PUMP)

Roller Chain Application

A properly selected, installed and maintained **drive chain** (Figure 28) is an extremely versatile means of power transmission. It is possible, however, to greatly reduce a chain's life and even induce failure if the chain is abused through improper installation, operating or maintenance procedures. In certain applications, failure can lead to personal injury or property damage.

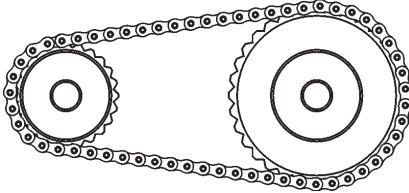

Figure 28. Drive Chain

Recommendations and comments on how to get the most from your roller chain drive are given in this section. The drive chain used in the MAYCO C-30HDNI pump is manufactured by the "DIAMOND CHAIN COMPANY™"

Working Loads

UTS-Ultimate Tensile Strength-is the one time pull required to break the chain. For single strand chain, the load (pull) applied to the chain in service should never exceed 1/6th of the UTS for the chain being used except as noted below.

It is possible to exceed the allowable working loads for a limited number of cycles, but you should contact Diamond Chain Company before this is considered. **A roller chain should never be loaded above 50% of UTS for even one cycle. To do so will damage the chain structure and reduce its capacity.**

The UTS or one time breaking load of multiple strand chain is the UTS of a single strand chain times the number of strands; i.e., two strand chain is twice as strong as single.

When allowable working loads are considered, however, the capacity of each strand in a multiple strand chain is only 65% of the single strand rating; thus, three-strand chain would rate not three times single but only 1.95 times. This is because the chain load cannot be exactly distributed across all three strands of the three-strand chain.

Installation and Drive Alignment

Chain and sprockets (Figure 29) must be installed correctly. Sprockets must be properly aligned and sprocket shafts must be parallel so the drive will run in a plane perpendicular to them. Axial alignment should be checked with a straight edge which will extend across the finished sides of the sprockets. They should be true-running with minimum wobble and eccentricity. The higher the drive speed, the more important these details become.

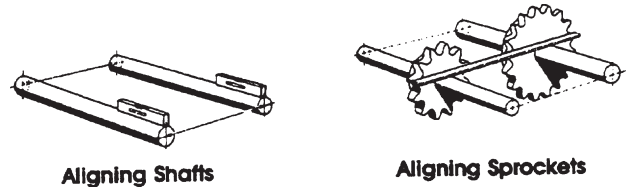

Figure 29. Shaft and Drive Sprocket Alignment

The chain should be installed so the slack span is properly tensioned. To check chain tension (Figure 30), turn one sprocket to tighten the upper span of the chain while holding the other sprocket fixed. The lack span should have 4-6% of span length in the mid-span movement for horizontal drives and 2-3% for vertical drives.

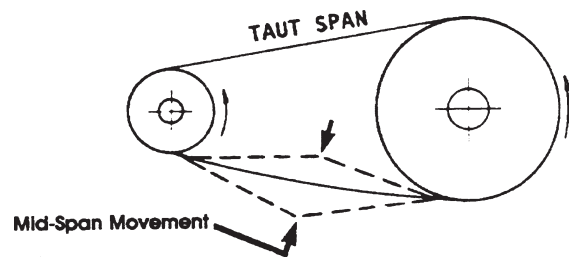

Figure 30. Drive Chain Tension

A roller chain's capacity can be significantly reduced if it is twisted or bent sideways in the direction of the pin axis. Exercise particular care in alignment of hoist or other applications where loads are suspended near personnel.

C-30HDNI (PRECISION) PUMP — MAINTENANCE (PUMP)

Drive Chain Lubrication

As a chain articulates in entering and leaving a sprocket, there is relative movement between pin and bushing surfaces. These surfaces wear causing chain elongation. If a lubricant film can be maintained between the pin and bushing, the wear rate is very slow and the chain wear life very long. Maintaining the oil film is relatively simple at low speeds but becomes increasingly difficult as the speed increases.

It is recognized that good lubrication is not possible in many applications, so shorter wear life must be accepted in these situations.

In general, chain wear leads to rough or unsatisfactory service prior to actual chain breakage. Good lubrication can help to prevent chain failure by providing protection against rust or corrosion. Rusting can allow pits to form in the surfaces of the chain parts causing stress concentration points. This can lead to chain failure at relatively low loads.

The clearance between pin and bushings is very small (Figure 31), on the order of .003 to .005 inches. A lubricant must be thin enough to flow into the chain. SAE 30 weight oil is about right for room temperature. Lighter oil should be used for lower ambients and heavier for higher operating temperatures. Grease should not be used as it cannot penetrate chain clearances.

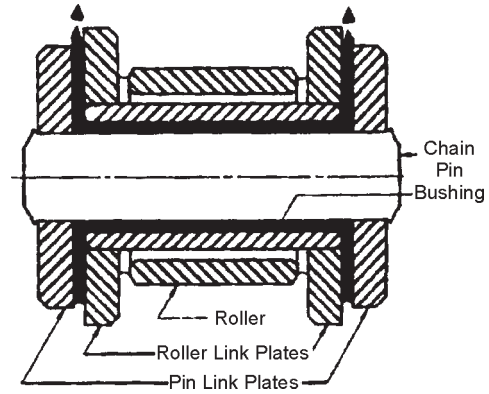

Figure 31. Chain-Link Cross Section

C-30HDNI (PRECISION) PUMP — MAINTENANCE (PUMP)

Assembling and Disassembling Drive Chain

CAUTION - DRIVE CHAIN SAFETY

You may be *seriously injured* if you attempt to install the drive chain while the pump is running. Turn **OFF** the engine and lock out gears and sprockets before attempting installation.

Once installed, the drive chain must be guarded to prevent personal injury or property damage in the event the chain separates during operation. **NEVER** run pump with drive chain guard removed.

CAUTION - Eyesight Hazard

The components of the drive chain are hardened parts. Striking these parts may cause metal chips to break off from the chain or the tools used resulting in personal injury.

During all stages of chain disassembly and assembly, wear *safety glasses* to prevent metal parts or chips from entering your eyes and have personnel in the immediate area do likewise.

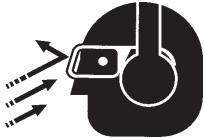

Chain-Link Pin Removal

1. If chain is of cotter pin- type construction, remove cotters.
2. If chain is riveted type construction, grind pin heads off so pin ends are flush with the linkplate.
3. Drive pins out of linkplate using a Diamond pin extractor Model P/N 113 or 135. Some multiple strand chains or large pitch models will require a hammer and punch or a press to remove the pins.

Installation Of Coversides

Diamond Chain coversides are manufactured three different ways:

- Slip Fit
- Modified Press Fit
- Full Press Fit

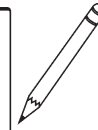
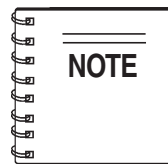

Modified and *Full Press Fits* require some patience and tools to assemble and/or disassemble. Use vice grips, plumbers pliers or a small hammer to drive coversides onto pins.

Installation of Spring Locks and Cotter-Pins

After coversides have been installed, install spring locks or cotters (depending on chain design). Avoid using bent or worn cotters or spring locks. After spring locks (or cotters) are installed, lightly tap pin ends to position these parts snug against the coverside for additional support.

Tips To Remember

- Chain will break if misused or abused
- Serious injury or property damage can result if chain is installed incorrectly.
- Select, install, guard and maintain chain in accordance with equipment manufacturer and "Diamond Chain Company's" recommendations.
- Read chain assembly instructions before attempting to install chain on pump sprocket wheel.
- Knowing more about how the chain is constructed may help in assembly and disassembly. Further information may be obtained by calling or writing Diamond Chain Company™.

C-30HDNI (PRECISION) PUMP — ENGINE TROUBLESHOOTING

Practically all breakdowns can be prevented by proper handling and maintenance inspections, but in the event of a breakdown, please take a remedial action following the diagnosis based on the Engine Troubleshooting (Table 6) information shown below and on the proceeding page. If the problem cannot be remedied, please leave the unit just as it is and consult our company's business office or service plant.

TABLE 6. ENGINE TROUBLESHOOTING

SYMPTON	POSSIBLE PROBLEM	SOLUTION
Engine will not start or start is delayed, although engine can be turned over.	Speed control lever is in "STOP" position?	Set speed control lever to "START" position.
	Defective fuel pump?	Replace fuel pump.
	Fuel filter clogged?	Replace fuel filter and clean tank.
	Faulty fuel supply line?	Replace or repair fuel line.
	Compression too low?	Check piston, cylinder and valves. Adjust or repair per engine repair manual.
	Oil pressure too low?	Check engine oil pressure.
	Low starting temperature limit exceeded	Comply with cold starting instructions and proper oil viscosity.
	Defective battery?	Charge or replace battery.
At low temperatures engine will not start.	Engine oil too thick?	Refill engine crankcase with correct type of oil for winter environment.
	Defective battery?	Replace battery.
Engine fires but stops soon as starter is switched off.	Throttle lever in STOP position?	Reposition throttle lever to RUN position.
	Fuel filter blocked?	Replace fuel filter.
	Fuel supply blocked?	Check the entire fuel system.
	Electrical problem at fuel solenoid?	Repair using #7 wire.
Engine stops by itself during normal operation.	Fuel tank empty?	Add fuel.
	Fuel filter blocked?	Replace fuel filter.
	Defective fuel pump?	Replace fuel pump.
	Mechanical oil pressure shutdown sensor stops the engine due to low oil?	Add oil. Replace low oil shutdown sensor if necessary.

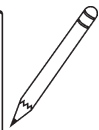
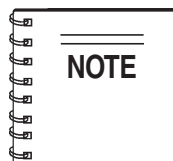

For more detail troubleshooting methods, refer to **NISSAN** Operation and Maintenance manual supplied with your pump.

C-30HDNI (PRECISION) PUMP — ENGINE TROUBLESHOOTING

TABLE 6. ENGINE TROUBLESHOOTING (CONTINUED)

SYMPTON	POSSIBLE PROBLEM	SOLUTION
Low engine power, output and speed.	Fuel tank empty?	Replace fuel filter.
	Fuel filter clogged?	Replace fuel filter.
	Fuel tank venting is inadequate?	Ensure that tank is adequately vented.
	Leaks at pipe unions?	Check threaded pipe unions tape and tighten unions as required.
	Engine oil level too full?	Correct engine oil level?
Low engine power output and low speed, black exhaust smoke.	Air filter blocked?	Clean or replace air filter.
	Incorrect valve clearances?	Adjust valves per engine specification.
Overheating	Insufficient coolant?	Replenish.
	Loose fan belt?	Adjust fan belt.
	Worn or oiled belt?	Replace belt.
	Inoperative thermostat?	Replace thermostat.
	Worn water pump?	Replace water pump.
	Clogged or leaky radiator?	Flush, repair or replace radiator.
	Faulty radiator filler cap?	Replace radiator cap.
	Air in cooling system?	Retighten each part of cooling system.
	Incorrect engine timing?	Adjust timing.
	Improper governor adjustment?	Adjust governor to the specified conditions.

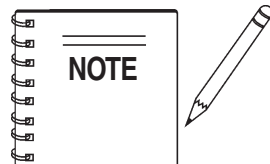

For more detail troubleshooting methods, refer to **NISSAN** Operation and Maintenance manual supplied with your pump.

C-30HDNI PUMP — MALFUNCTION INDICATOR DIAGNOSTIC ERROR CODES

Malfunction Indicator Diagnostic System

The Mayco C-30HDNI concrete pump features an engine malfunction indicator LED, found on the control panel (Figure 5). When a malfunction in the operation of the engine is detected, the light will blink in sequence to indicate an error code. Use the Diagnostic Error Code Table (Table 7) to troubleshoot the malfunction.

Determining an Error Code

The malfunction indicator light blinks in two patterns; long and short. Count the long blinks to determine the first digit of the error code. Count the short blinks to determine the second digit of the error code.

For example, four long blinks and three short blinks represent error code 43, indicating a faulty fuel injector.

TABLE 7. MALFUNCTION INDICATOR DIAGNOSTIC ERROR CODES

ERROR CODE	DESCRIPTION OF ERROR	POSSIBLE CAUSES OF ERROR
12	<p>Special case error code that is not logged into the ECM's EEPROM Memory when detected. When the power to the ECM is "ON" and the ECM detects no crankshaft reference pulses coming from the engine, it illuminates the malfunction indicator light.</p> <p>Code 12 is also used when the ECM is in diagnostic mode (engine OFF) to signal the beginning or end of the diagnostic sequence when the ECM outputs each stored error code via the LED error indicator light.</p> <p>When in this mode, the ECM will begin by flashing code 12 via one LED blink followed by a pause and then two quick LED blinks and a pause indicating the beginning of a diagnostic sequence. It will then flash all error codes stored in EEPROM. When all stored error codes have been displayed, the ECM will again flash code 12 again followed by a long pause to indicate the end of the diagnostic sequence.</p>	<p>This cycle will continue as long as the ECM is in diagnostic mode.</p> <p>NOTE: When in this mode, error codes are displayed in numerical order rather than the order of occurrence.</p>
13	<p>Error Code 13 indicates an oxygen sensor error. Indicates that the exhaust stream oxygen sensor (O₂ sensor) is not responding correctly. When cold, the sensor has a defaulted value. before it warms up, it acts as an open circuit and the ECM will read the bias value. The ECM expects the sensor to warm up in a short period of time and begin sending its own voltages.</p> <p>Conditions for displaying this error code are:</p> <ul style="list-style-type: none"> ● Engine running at least 5 minutes ● No Code 21 TPS errors present ● Engine coolant temperature greater than or equal to 90°F ● O₂ sensor voltage not fluctuating from 0.3V-0.7V ● TPS signal indicates above idle ● Error conditions are present for at least 60 seconds. 	<ul style="list-style-type: none"> ● Defective O₂ sensor ● O₂ sensor is corroded with contaminants ● O₂ sensor connection is bad
14	<p>Error Code 14 indicates that the Engine Coolant Temperature (ECT) sensor is reporting abnormally high readings. ECT is used to control fuel mixture, timing, and idle speed. The termistor used has a low resistance when hot, rising as the coolant cools. This error then, indicates a very low resistance in the ECT circuit.</p> <p>Conditions for displaying this error code are:</p> <ul style="list-style-type: none"> ● Coolant temperature reported is greater than 284°F (140°C) ● The above condition is present for more than 2 seconds <p>NOTE: A default temperature of 170°F (77°C) while the error is present during normal runtime.</p>	<ul style="list-style-type: none"> ● Severe engine overheating ● Defective ECT ● Short circuit in ECT-ECM harness ● Defective ECM
15	<p>Error Code 15 indicates that the Engine Coolant Temperature (ECT) sensor is reporting abnormally low readings. ECT is used to control fuel mixture, timing, and idle speed.</p> <p>Conditions for displaying this error code are:</p> <ul style="list-style-type: none"> ● Coolant temperature reported is less than -31°F (35°C) and ● The above condition is present for more than 2 seconds <p>NOTE: A default temperature of 170°F (77°C) while the error is present during normal runtime.</p>	<ul style="list-style-type: none"> ● Open circuit in ECT-ECM harness ● Defective ECT ● Open sensor ground circuit ● Defective ECM
21	<p>Error Code 21 indicates that the Throttle Position Sensor (TPS) is reading incorrectly. TPS voltage should be approximately 1.0V at closed throttle and rise smoothly to a maximum of approximately 3.6V at WOT.</p> <p>Conditions for displaying this error code are:</p> <ul style="list-style-type: none"> ● Engine is running, and ● TPS reading is less than 0.25V or greater than 4.5V <p>NOTE: A default temperature of 170°F (77°C) while the error is present during normal runtime.</p>	<ul style="list-style-type: none"> ● Defective TPS ● Short circuit in the TPS harness to +5 volt reference ● Open sensor ground circuit ● Defective ECM

C-30HDNI PUMP — MALFUNCTION INDICATOR DIAGNOSTIC ERROR CODES

TABLE 7. MALFUNCTION INDICATOR DIAGNOSTIC ERROR CODES (Continued)

ERROR CODE	DESCRIPTION OF ERROR	POSSIBLE CAUSES OF ERROR
22	<p>Error Code 22 indicates that the throttle body actuator is not responding to input current.</p> <p>Conditions for displaying this error code are:</p> <ul style="list-style-type: none"> ● Engine does not change speed per actuator demand function ● ECM is commanding a solenoid duty cycle of between 5% and 95% ● No electrical feedback is being received from the solenoid ● The above condition is present for more than 2 seconds 	<ul style="list-style-type: none"> ● Defective actuator ● Defective ECM ● Defective actuator to ECM wiring
23	<p>Error Code 23 indicates that the Inlet Air Temperature (IAT) sensor is reporting abnormally low readings. When the air is cold, the thermistor has a high resistance, which falls as the air temperature rises. Low readings thus indicate a possible bad sensor or open in the IAT circuit.</p> <p>Conditions for displaying this error code are:</p> <ul style="list-style-type: none"> ● IAT reading is less than -40°F (-40°C) ● The above condition is present for more than 2 seconds <p>NOTE: A default IAT value indicating 80°F (27°C) is used while Code 23 is present.</p>	<ul style="list-style-type: none"> ● Defective IAT sensor ● Defective ECM ● Open sensor ground circuit ● Dirty or corroded connection(s) at IAT and/or ECM ● Open circuit between ECM and IAT sensor
24	<p>Error Code 24 indicates that the Inlet Air Temperature (IAT) sensor is reporting abnormally high readings. When the air is hot, the thermistor has a low resistance, which rises as the air temperature cools. High readings thus indicate a possible bad sensor or short in the IAT circuit.</p> <p>Conditions for displaying this error code are:</p> <ul style="list-style-type: none"> ● IAT reading is greater than 275°F (135°C) 	<ul style="list-style-type: none"> ● Defective IAT sensor ● Defective ECM ● IAT signal shorted to ground or to sensor ground
25	<p>Error Code 25 indicates that there may be a malfunction in the Electronic Ignition Control Circuit. The ECM senses spark knock (pinging) and retards the timing to eliminate it. A knock sensor (located at the rear of the engine block) sends signals to the ECM that knocking is being detected. The ECM will retard the timing by as much as 10°, in 1° increments.</p> <p>A loss of knock sensor signal or loss of ground at the ECM module will cause the signal at the ECM to remain low. The ECM will act as if no knock is present, and may possibly result in engine damage, if there is detonation. Loss of the knock sensor signal to the ECM will cause the ECM to constantly retard the timing to its maximum. This results in sluggish performance and a Code 25</p> <p>Conditions for displaying this error code are:</p> <ul style="list-style-type: none"> ● Engine is running ● Knock input signal has been high more than 1 seconds. ● Applies only to knock sensor equipped engines 	<ul style="list-style-type: none"> ● Open or shorted knock sensor ● Loose knock sensor ● Excessive mechanical noise within engine ● Defective ECM
31	<p>Error Code 31 indicates that the Drive by Wire (DBW) sensor readings may not be incorrect. The DBW signal must be between 0.5V and 4.8V during operation.</p> <p>Conditions for displaying this error code are:</p> <ul style="list-style-type: none"> ● Engine is running ● DBW reading is less than 0.5V -OR- ● DBW reading is greater than 4.8V 	<ul style="list-style-type: none"> ● Defective DBW input from sensor or pedal ● DBW signal shorted to ground or to sensor ground ● Defective ECM
32	<p>Error Code 32 indicates that the System Voltage or Battery Level is too low.</p> <p>Conditions for displaying this error code are:</p> <ul style="list-style-type: none"> ● System Voltage is below 9V 	<ul style="list-style-type: none"> ● Faulty battery ● Power wire from battery ● Poor ground wiring ● Defective ECM ● Bad charging system

C-30HDNI PUMP — MALFUNCTION INDICATOR DIAGNOSTIC ERROR CODES

TABLE 7. MALFUNCTION INDICATOR DIAGNOSTIC ERROR CODES (Continued)

ERROR CODE	DESCRIPTION OF ERROR	POSSIBLE CAUSES OF ERROR
41	<p>Error Code 41 indicates that there may be a malfunction in the Manifold Air Pressure (MAP) sensor system. When the engine speed exceeds 400 RPM's, the MAP sensor should read lower than the returned value before the engine has started. The engine can be re-started in a default limp-mode operation.</p> <p>Conditions for displaying this error code are:</p> <ul style="list-style-type: none"> ● An open or ground in the circuit which stalls the engine 	<ul style="list-style-type: none"> ● Bad vaccum line to sensor ● Defective MAP sensor ● Open sensor ground circuit ● Dirty or corroded connection(s) at MAP sensor ● Open circuit between the ECM and MAP sensor ● Defective ECM
42	<p>Error Code 42 indicates that there may be a malfunction in the Electronic Spark Trigger (EST) system. During cranking, the timing is controlled by the ignition module while the ECM monitors the engine speed. When the engine exceeds 400 RPM's, the ECM sends a Bypass signal to the ignition module which switches the timing to ECM control.</p> <p>The ECM calculates what the timing should be then "tells" the ignition module via this circuit. The engine can be re-started but it will run on ignition mode timing only.</p> <p>Conditions for displaying this error code are:</p> <ul style="list-style-type: none"> ● An open or ground in the EST circuit which stalls the engine ● System in Bypass mode but the ignition module is still controlling timing <p>-OR-</p> <ul style="list-style-type: none"> ● Engine speed is greater than 600 RPM's with no EST pulses (ECM controlled timing) going to the ignition module for 200 milli-seconds. 	<ul style="list-style-type: none"> ● Bypass line is open or grounded ● EST line is open or grounded ● Defective ECM ● Poor connections between ignition module and ECM ● Poor routing of EST harness and/or poor quality ignition wires (EMI induced electrical noise) ● Faulty or incorrect ignition module
43	<p>Error Code 43 indicates that the gasoline injector is faulty.</p> <p>Conditions for displaying this error code are:</p> <ul style="list-style-type: none"> ● ECM is commanding the fuel injector output to be On or OFF ● Electrical feedback to the ECM indicates a short circuit fault or an open circuit fault 	<ul style="list-style-type: none"> ● Bad vaccum line to sensor ● Defective MAP sensor ● Open sensor ground circuit
51	<p>Error Code 51 indicates that the ECM sensed a fault in the EEPROM. When the PROM is initially created, a checksum number representing the total of all the cell values is also stored. The ECM used this checksum to determine if the contents of any cell has changed. A Code 51 causes the ECM to enter Back-Up mode which uses default sensor values.</p> <p>Conditions for displaying this error code are:</p> <ul style="list-style-type: none"> ● Power has just been applied to the ECM ● The calculated checksum does not match the stored checksum <p>-OR-</p> <ul style="list-style-type: none"> ● The engine was just started ● Either of two specific EEPROM locations do not contain the expected value. One location should have 1's in the odd numbered bits and the other has 1's in the even numbered bit positions. 	<ul style="list-style-type: none"> ● Incorrectly installed PROM module ● Defective PROM module ● Defective ECM
52	<p>Error Code 52 indicates that the Analog-to-Digital (A/D) converter in the ECM is faulty. This converter reads sensors (e.g., TPS, O₂ sensor, etc.) and converts their analog voltage output to a dignital number for use by the ECM. If the A/D converter fails, the ECM sets this code.</p> <p>Conditions for displaying this error code are:</p> <ul style="list-style-type: none"> ● A/D Converter has failed to properly read a sensor after 5 attempts 	<ul style="list-style-type: none"> ● Defective ECM

C-30HDNI PUMP — MALFUNCTION INDICATOR DIAGNOSTIC ERROR CODES

TABLE 7. MALFUNCTION INDICATOR DIAGNOSTIC ERROR CODES (Continued)

ERROR CODE	DESCRIPTION OF ERROR	POSSIBLE CAUSES OF ERROR
53	<p>Error Code 53 indicates that Oil Pressure Level is low.</p> <p>Conditions for displaying this error code are:</p> <ul style="list-style-type: none"> ● Oil Pressure Level signal has grounded after the engine has been running for 10 seconds. 	<ul style="list-style-type: none"> ● Low Oil level ● Bad Oil Pump
61	<p>Error Code 61 indicates that the LP solenoid relay output is faulty.</p> <p>Conditions for displaying this error code are:</p> <ul style="list-style-type: none"> ● ECM is commanding the LP solenoid relay output ON or OFF ● Electrical feedback to the ECM indicates any one of the following faults: short circuit fault, over-current fault, over-voltage fault, or an open circuit fault 	<ul style="list-style-type: none"> ● Defective ECM ● Open circuit (wiring connected) ● Short circuit in relay circuit ● Voltage level above 28V
62	<p>Error Code 62 indicates that the Fuel Pump relay output is faulty.</p> <p>Conditions for displaying this error code are:</p> <ul style="list-style-type: none"> ● ECM is commanding the Fuel Pump relay output ON or OFF ● Electrical feedback to the ECM indicates any one of the following faults: short circuit fault, over-current fault, over-voltage fault, or an open circuit fault 	
63	<p>Error Code 63 indicates that the Dual Fuel relay output is faulty.</p> <p>Conditions for displaying this error code are:</p> <ul style="list-style-type: none"> ● ECM is commanding the Dual Fuel relay output ON or OFF ● Electrical feedback to the ECM indicates any one of the following faults: short circuit current-current fault, over-voltage fault, or an open circuit fault 	
64	<p>Error Code 64 indicates that the Ignition Power relay output is faulty.</p> <p>Conditions for displaying this error code are:</p> <ul style="list-style-type: none"> ● ECM is commanding the Ignition Power relay output ON or OFF ● Electrical feedback to the ECM indicates any one of the following faults: short circuit current-current fault, over-voltage fault, or an open circuit fault 	

C-30HDNI PUMP — COMPONENT LOCATION (EFI WIRING HARNESS)

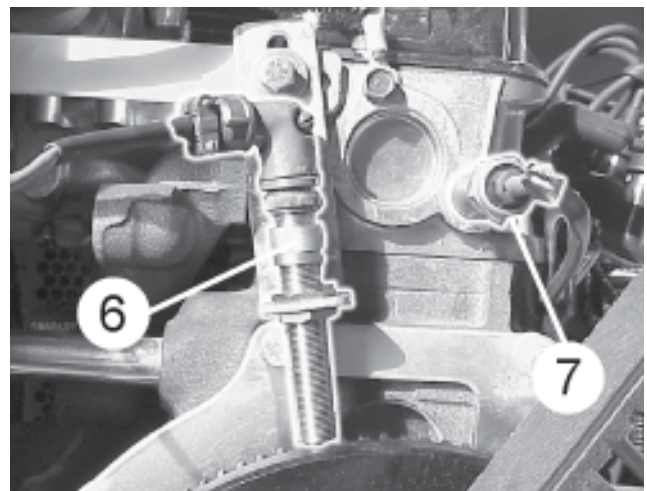
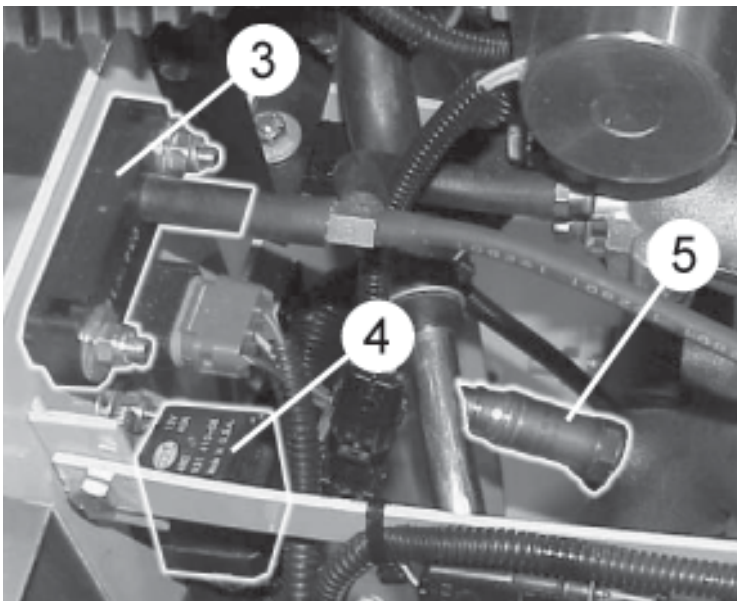
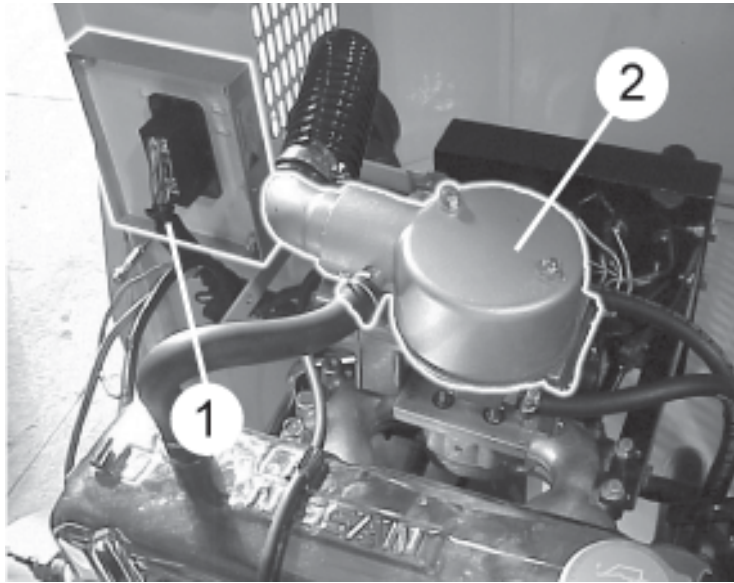

TABLE 8. EFI SYSTEM COMONPONENTS

1	EFI Controller	5	Oxygen Sensor
2	Fuel Injection Body Assy.	6	Magnetic Pick-up Sensor
3	Manifold Absolute Pressure Sensor	7	Temperature Sensor
4	Fuel Injection Relay		

C-30HDNI PUMP — WIRING DIAGRAM (EFI WIRING HARNESS)

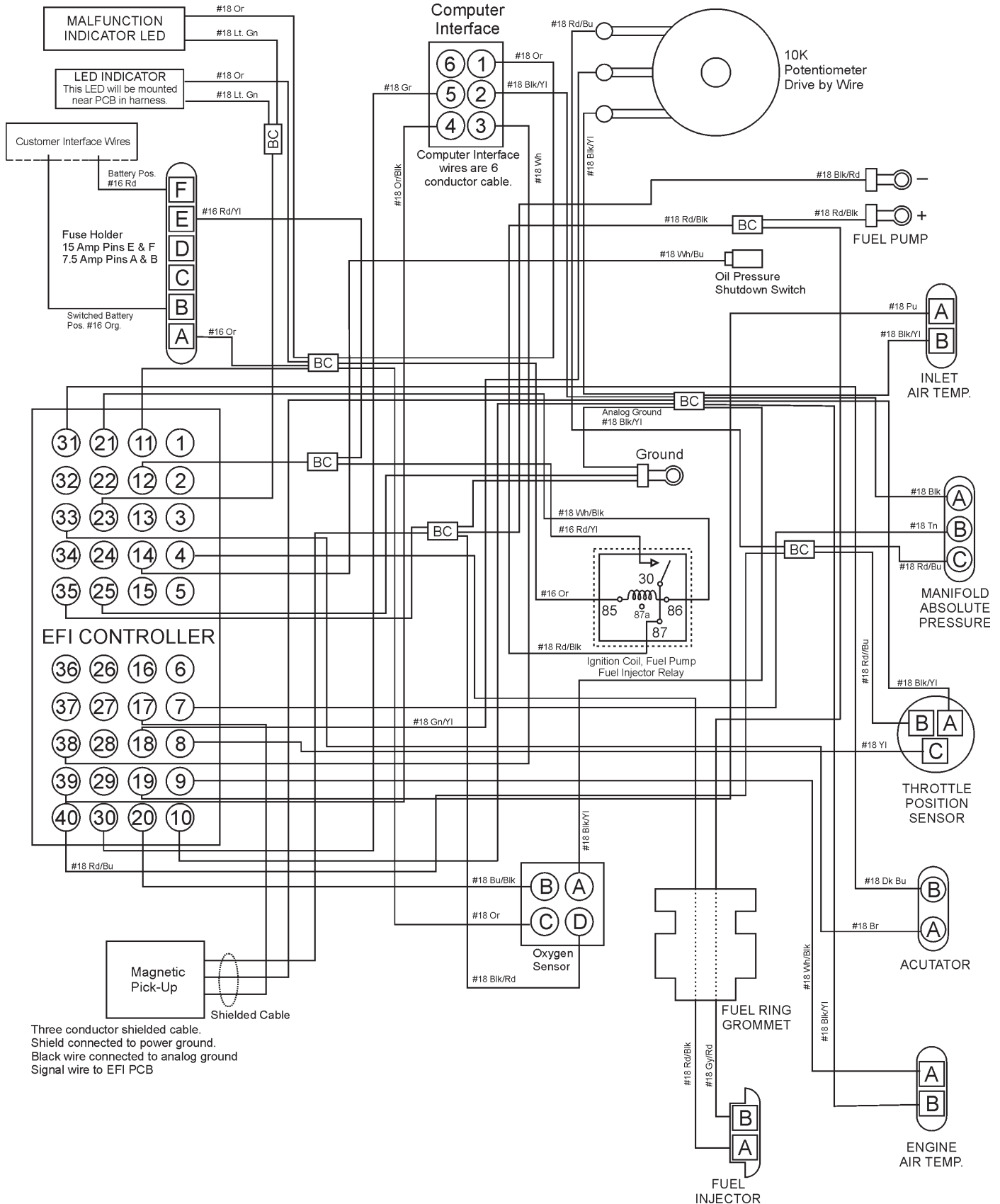

Figure 32. EFI Wiring Diagram

C-30HDNI (PRECISION) PUMP — WIRING DIAGRAM

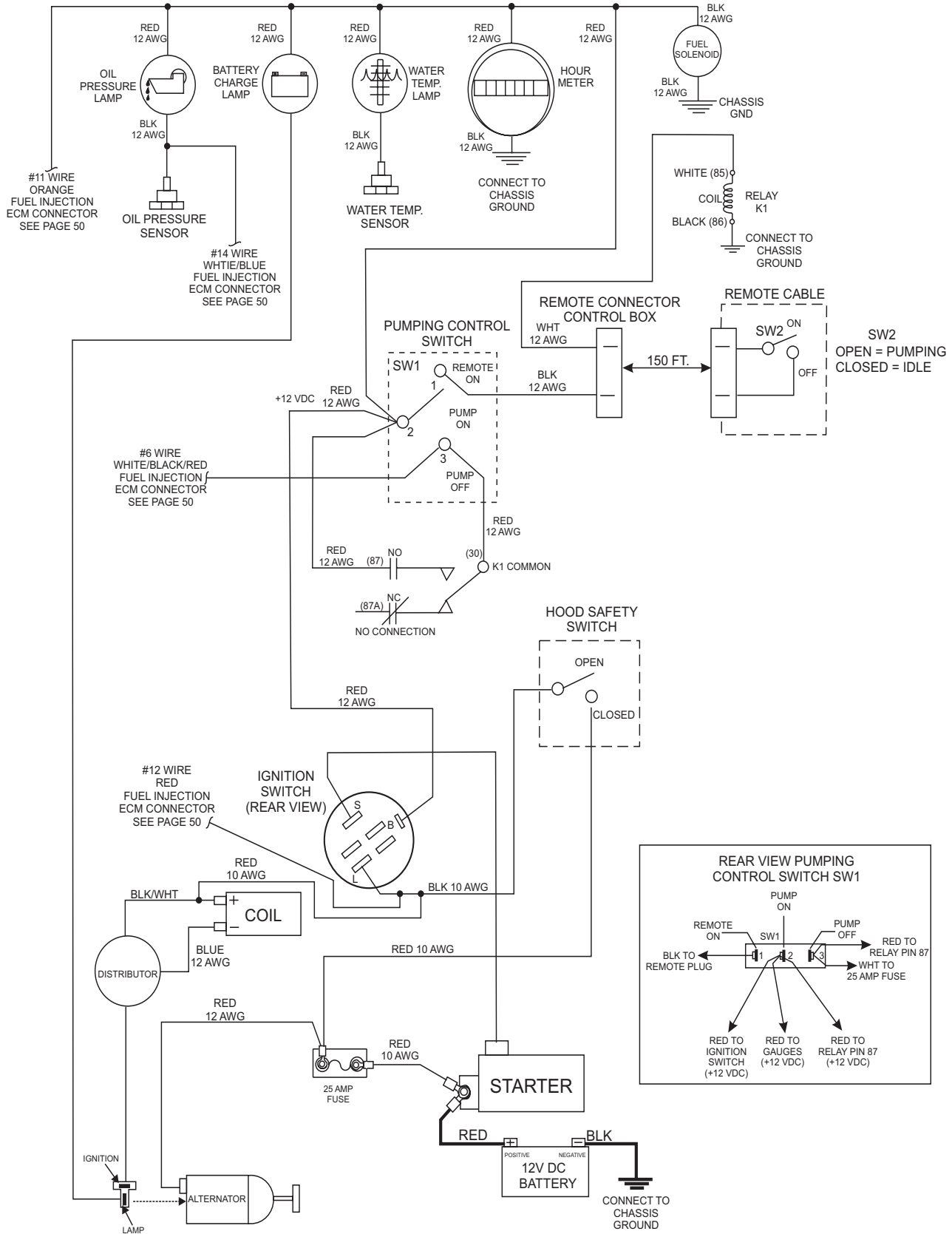

Figure 33. Wiring Diagram

C-30HDNI (PRECISION) PUMP — WIRING DIAGRAM (TAIL LIGHTS)

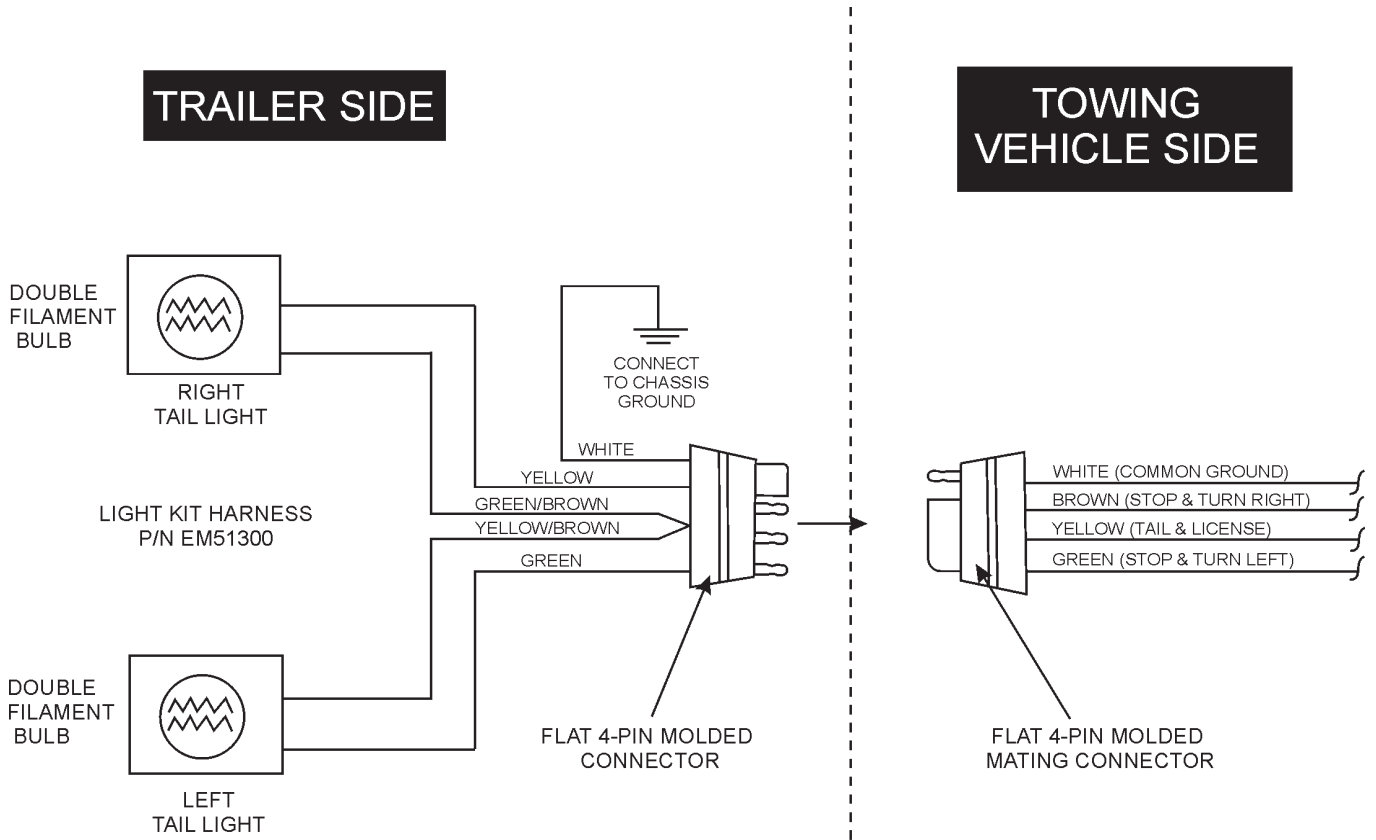

Figure 34. Trailer Tail Lights Wiring Diagram

APPENDIX — C-30HDNI C-30HDNI SLUMP TEST PROCEDURE

- To obtain a representative sample (concrete), take several samples at three or more regular intervals throughout the discharge of the mixer or truck. **DO NOT** take samples at the beginning or end of the discharge.
- Dampen the inside of the cone and place it on a smooth, moist, nonabsorbent, level surface large enough to accommodate both the slumped concrete and the slump cone. Stand on the "foot pieces" throughout the test procedure to hold the cone firmly in place.
- Fill the cone 1/3 full by volume (Figure 35-A) and rod 25 times with a 1/2" dia x 24" lg. bullet-pointed steel rod. (This is a specific requirement which will produce non-standard results unless followed exactly.) Distribute rodding evenly over the entire cross section of the sample.
- Fill cone another 1/3 (Figure 35-B) which will make the cone 2/3 full by volume. Rod this second layer 25 times with the rod penetrating into, but not through, the first layer. Distribute rodding evenly over the entire cross section of the layer.
- Fill cone to overflowing (Figure 35-C). Rod this layer 25 times with rod penetrating into but not through, the second layer. Distribute rodding evenly over the entire cross section of this layer.
- Remove the excess concrete (Figure 35-D) from the top of the cone, using the tamping rod as a screed.
- Lift the cone vertically (Figure 35-E) with a slow even motion. **DO NOT** jar the concrete or tilt the cone during this process. (Invert the withdrawn cone, and place it next to, but not touching the slumped concrete.
- Lay a straight edge (Figure 35-F) across the top of the slumped cone. Measure the amount of slump in inches from the bottom of the straight edge to the top of the slumped concrete at a point over the original center of the base . The slump operation must be complete in a maximum elapsed time of 1-1/2 minutes. Discard the concrete. **DO NOT** use it in any other tests.

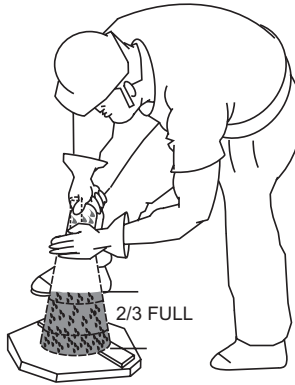

Figure 35-B. Slump Test (2/3 Full)

Figure 35-C. Slump Test (Full-Overflow)

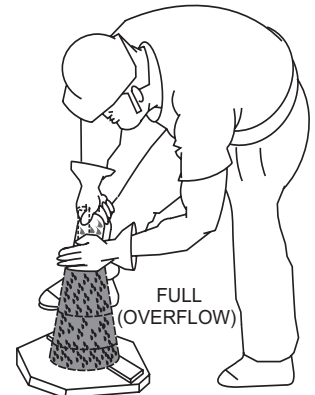

Figure 35-D. Slump Test (Removing Excess Concrete)

Figure 35-E. Slump Test (Cone Invert)

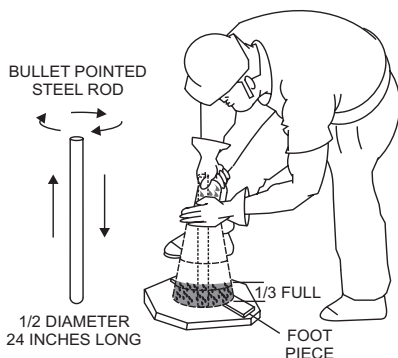
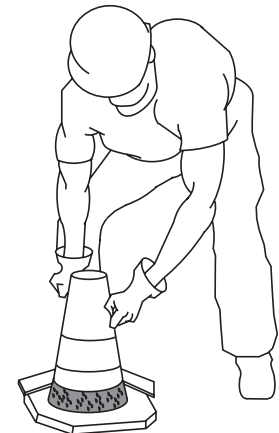

Figure 35-A. Slump Test (1/3 Full)



Figure 35-F. Slump Test (Measurement)

APPENDIX — C-30HDNI CONCRETE MIX INFORMATION

The following information has been extracted from actual testing laboratory reports. The purpose of this printing is only to help create a better understanding of the importance of uniform gradation and proportioning of materials which affect pumpability of concrete mixes. These weights and proportions illustrate that when the sieve analysis is ideal, the sand/rock ratio can be adjusted (65% sand 35% rock) and pumpability should be excellent.

EXAMPLE #1 (A California Test Lab. Report)

JOB: Building Foundations (Water Project)

Sacks per cu./yd.	6.5 designed for 2,500 lbs. in 28 days
Gallons per sack	7.1
Washed Sand-#200 wash	1.3
Organic matter-OK	
Specific gravity (SSD)	Sand-2.58; Pea Gravel-2.60

Sieve analysis-percent passing

Material	1.5"	1"	3/4"	3/8"	#4	#8	#16	#30	#50	#100	#200
W.C. Sand				100	99.7	79.1	60.4	36.5	14.3	4.0	1.1
Pea Gravel				100	3.0						
% Comb.				100	66	51	39	23	9	3	1.0













DESIGN FOR ONE YARD OF CONCRETE (SATURATED & SURFACE DRY):

Absolute volume of aggregate in one cu. yard:	17.78 cu. ft.
Specific gravity of aggregates in one cu. yard:	2.58
Weight of aggregates in one cu. yard batch:	2850 lbs.

	<u>%</u>	<u>BATCH</u>	<u>SPEC. GRAVITY</u>	<u>ABS. VOL.</u>
W.C. Sand	65	1800	2.58	11.56
PEA GRAVEL	35	1000	2.60	6.22
WATER 46 gal.		1		
CEMENT 6.5 sk.		611		
TOTAL				27.00
ADMIXTURE:		None		
SLUMP		4"		
REMARKS		This mix designed for pumping		
NOTE:		Due to the availability of well-graded sand as shown in the above sieve analysis, this mix pumped very successfully.		

APPENDIX — C-30HDNI CONCRETE MIX INFORMATION

A.S.T.M. STANDARD SPECIFICATION FOR GRADING AGGREGATE

SCREEN TYPE	U.S.	METRIC	PERCENTAGE PASSING BY WEIGHT
FINE AGGREGATE: Referred to as washed concrete sand.			
3/8" 	3/8"	9.50 mm	100%
#4 	4,760 microns	4.76 mm	95 to 100%
#8 	2,380 microns	2.38 mm	80 to 100%
#16 	1,190 microns	1.19 mm	50 to 85%
#30 	590 microns	.59 mm	50 to 85 %
#50 	297 microns	297µm	10 to 30%
#100 	149 microns	149µm	2 to 10%
3/8 (9.51 mm) PEA GRAVEL AGGREGATE: Referenced to as #4 Rock or Gravel or 1/2" minus (12.7 mm) size			
1/2" 	1/2"	12.70 mm	100%
3/8" 	3/8"	9.51 mm	85 to 100%
#4 	4,760 microns	4.76 mm	10 to 30%
#8 	2,380 micron	2.38 mm	0 to 10%
#16 	1,190 microns	1.19 mm	0 to 5%

APPENDIX — C-30HDNI CONCRETE MIX INFORMATION

Consolidated Rock Products Co., Division of Tests

3/8" Pea Gravel STANDARD PUMP MIXES (one-half inch minus)

NOTE: All weights shown are one cubic yard with S.S.D. aggregates.

CRP Mix Number	6004	6005	6006	6007
Design Slump (in.)	6" (15 cm)	6" (15 cm)	6" (15 cm)	6" (15 cm)
Cement, SACK.	7.0	7.0	7.0	7.0
Cement, Lbs.	658 (298 kg)	658 (298 kg)	658 (298 kg)	658 (298 kg)
w/Con Sand (1 lb.)	2031 (920 kg)	2982 (943 kg)	1879 (851 kg)	1943 (880 kg)
Gravel #4(9.51 mm)	677 (307 kg)	693 (314 kg)	806 (365 kg)	832 (377 kg)
TOTAL AGGREGATE	2708 (1227 kg)	2775 (1257 kg)	2685 (1216 kg)	2775 (1257 kg)

ADMIXTURE

Pozzolight 311-1 lb.	1.4 (.63 kg)	1.4 (.63 kg)	1.4 (.63 kg)	—
Water, Design (gals.)	50.0 (189 liters)	53.0 (200 liters)	50.0 (189 liters)	53.9 (200 liters)
Mater, Max. (gals.)	50.0 (189 liters)	53.0 (200 liters)	53.0 (200 liters)	53.0 (200 liters)

NOTE: Multiply above kilograms and liters by 1.308 to obtain the proportions for one cubic meter of concrete.

Consolidated Rock Products Co., Division of Tests

3/8" Pea Gravel STANDARD PUMP MIXES (one-half inch minus)

NOTE: All weights shown are one cubic yard with S.S.D. aggregates.

CRP Mix Number	6000	6001	6002	6003
Design Slump (in.)	6" (15 cm)	6" (15 cm)	6" (15 cm)	6" (15 cm)
Cement, SACK.	6.5	6.5	6.5	6.5
Cement, Lbs.	611 (276 kg)	611 (276 kg)	611 (276 kg)	611 (276 kg)
w/Con Sand (1.1 lb.)	2062 (934 kg)	2112 (957 kg)	1924 (872 kg)	1971 (893 kg)
Gravel #4 (9.51mm)	687 (311 kg)	704 (319 kg)	825 (374 kg)	845 (383 kg)
TOTAL AGGREGATE	2749 (1245 kg)	2816 (1276 kg)	2749 (1245 kg)	2816 (1276 kg)

ADMIXTURE

Pozzolight 311-1.3lb.	1.3 (.59 kg)	1.3 (.59)	—		
Water, Design (gals.)	50.0 (189 liters)	53.0 (200 liters)	50.0 (189 liters)	53.9 (200 liters)
Mater, Max. (gals.)	50.0 (189 liters)	53.0 (200 liters)	53.0 (200 liters)	53.0 (200 liters)

NOTE: Multiply above kilograms and liters by 1.308 to obtain the proportions for one cubic meter of concrete.

APPENDIX — RECOMMENDED SHOTCRETE SYSTEM

RECOMMENDED SHOTCRETE SYSTEM

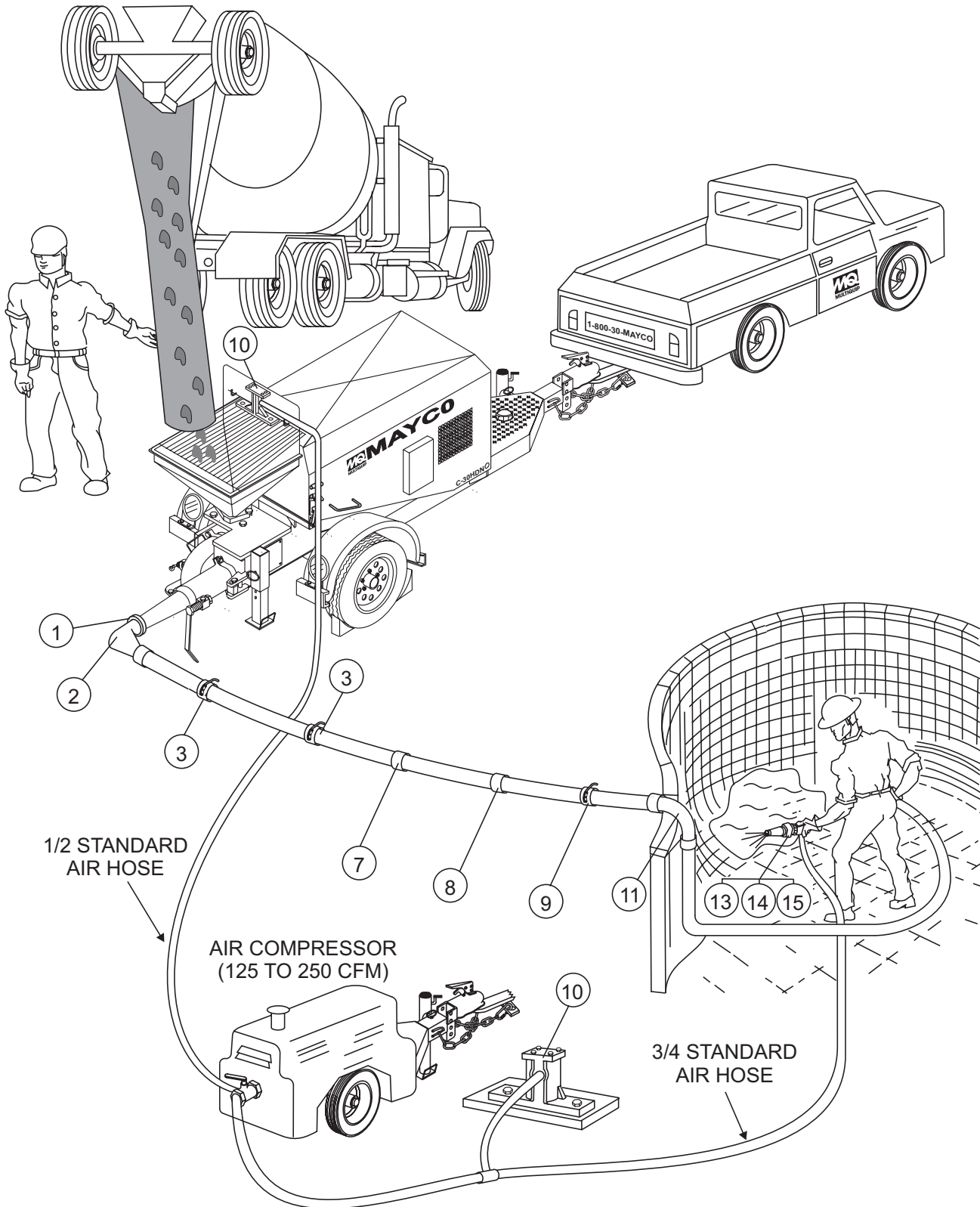

Figure 36. Shotcrete System

APPENDIX — RECOMMENDED SHOTCRETE SYSTEM

RECOMMENDED SHOTCRETE SYSTEM

<u>NO.</u>	<u>PART NO.</u>	<u>PART NAME</u>	<u>QTY.</u>	<u>REMARKS</u>
1	EM28904	3" "B" COUPLING		
2	EM23946	3"-90° ELBOW		
3	EM28903	2 1/2" S/J COUPLING		
4	EM28005DD	3"X 2 1/2 REDUCER		
5	EM28061	2 1/2"X 10FT. PIPE		
6	EM24849	2 1/2"X 50FT. HOSE		
7	EM28001DD	2 1/2"X 2" REDUCER		
8	EM23815D	2 1/2"X 2" REDUCER W/AIR VIBRATOR		
9	EM28902	2" S/J COUPLING		
10	EM23101	AIR VIBRATOR		
11	EM28131	2"X 2 ELBOW		
12	EM24841	2"X 25 FT. HOSE		
13	EM23808D	NOZZLE ASSEMBLY		
14	EM23806	1 3/8" NOZZLE TIP		
15	EM23807	1 1/4" NOZZLE TIP		

General recommendations

- If the site will permit, use steel pipe from the pump to the pool perimeter. It will reduce line pressures which is highly recommended.
- The vibrator on the reducer by the pool improves pumpability.
- Turn both air vibrators off whenever the pump is stopped to prevent separation of mix.
- The air vibrators are low consumption (4.2 scfm).
- Leave the air on at the nozzle when the pump is stopped to prevent clogging of air the hoses in the air insert.
- Use item #11 (steel elbow) at the edge of the pool to prevent collapse of the rubber hose, which can cause blockage.

APPENDIX — RECOMMENDED SHOTCRETE ACCESSORIES

RECOMMENDED SHOTCRETE ACCESSORIES

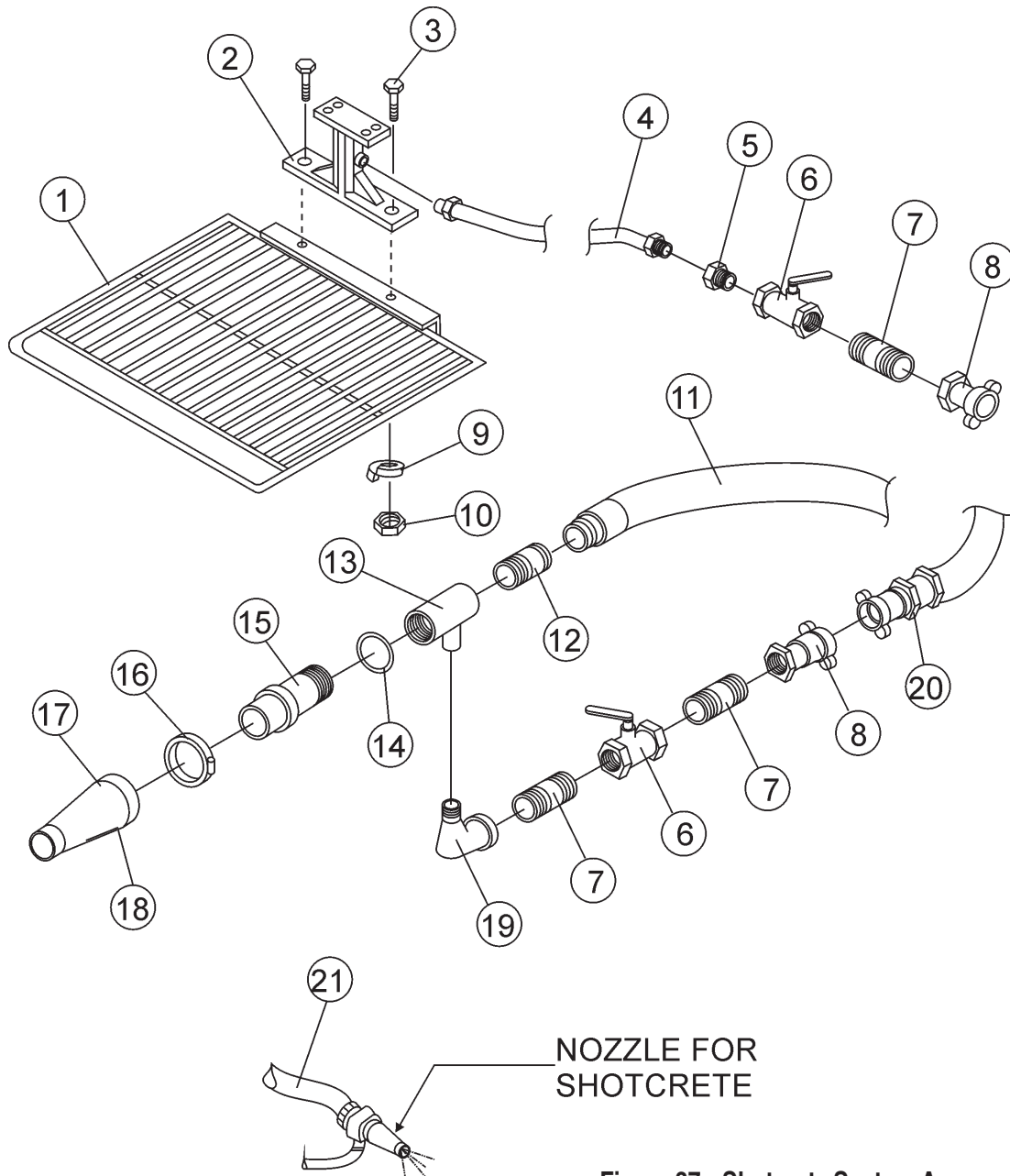
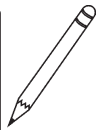
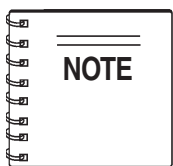

Figure 37. Shotcrete System Accessories



Use a 1-3/8" rubber nozzle tip for a wide spray pattern. Use a 1-1/4" rubber nozzle tip for a narrow spray pattern. **DO NOT INSTALL THE NOZZLE AT THE END OF THE HOSE UNTIL THE FIRST MATERIAL HAS PASSED THROUGH THE ENTIRE HOSE LENGTH.**

Disassemble and clean the nozzle assembly thoroughly after each job. Grease all threads before re-assembly. **DO NOT** close the air valve when pumping is stopped as a continued air flow keeps the air passages clean.

APPENDIX — RECOMMENDED SHOTCRETE ACCESSORIES

RECOMMENDED SHOTCRETE ACCESSORIES

<u>NO.</u>	<u>PART NO.</u>	<u>PART NAME</u>	<u>QTY.</u>	<u>REMARKS</u>
1	EM26107	HOPPER SCREEN	1	
2	EM231011	AIR VIBRATOR	1	
3	EM132	BOLT, 1/2-13X2	2	
4	EM23407	AIR HOSE	1	
5	EM23408	BUSHING	1	
6	EM23411	VALVE	1	
7	EM912073	NIPPLE	2	
8	EM23409	COUPLING	1	
9	EM923346	WASHER, 1/2 LOCK	2	
10	EM406	NUT, HEX 1/2-13	2	
11	EM23818	2"X25' GROOVED HOSE		
	EM24841	2"X25' RAISED HOSE		
	EM23845	2"X50' GROOVED HOSE		
12*	EM23802	ADAPTER	1	
13*	EM23803	GUN BODY	1	
14*	EM20816	"O" RING	1	
15*	EM23804	AIR INSERT	1	
16*	EM23805	NOZZLE CLAMP	1	
17*	EM23806	NOZZLE TIP, 1-3/8"	1	
18*	EM23807	NOZZLE TIP, 1-1/4"	1	
19*	EM911076	STREET ELBOW	1	
20		AIR HOSE		NOT SUPPLIED BY MAYCO
21	EM23808	NOZZLE ASSEMBLY	1	INCLUDES. ITEMS W/*

C-30HDNI PUMP — EXPLANATION OF CODE IN REMARKS COLUMN

How to read the marks and remarks used in this parts book.

Items Found In the “Remarks” Column

Serial Numbers-Where indicated, this indicates a serial number range (inclusive) where a particular part is used.

Model Number-Where indicated, this shows that the corresponding part is utilized only with this specific model number or model number variant.

Items Found In the “Items Number” Column

All parts with same symbol in the number column, *, #, +, %, or >, belong to the same assembly or kit.

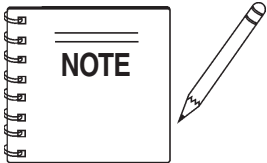

If more than one of the same reference number is listed, the last one listed indicates newest (or latest) part available.

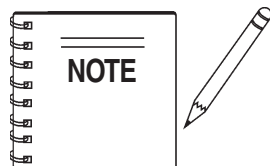

The contents of this catalog are subject to change without notice.

C-30HDNI PUMP — SUGGESTED SPARE PARTS

C-30HDNI CONCRETE PUMP W/ PRECISION FUEL INJECTION SYSTEM 1 Units

QTY.	P/N	DESCRIPTION
6	EM14904	PISTON CUP KITS
4	EM18804	4 1/2" STEEL BALL
4	EM14818	4" STEEL BALL
6	EM14903	BALL STOP PIN KIT
10	EM18801	O-RING MANIFOLD
1	EM14308	CHAIN
2	EM26313	HALF LINK
2	EM26314	MASTER LINK
1	EM14334	COMPENSATOR SPRING
2	EM14408	BRONZE RING
2	EM903092	CAM ROLLER BEARING
2	EM14315	V-BELT
2	EM14842	LOWER SEAT
2	EM14843	UPPER SEAT
2	EM26310	CLUTCH LINING
10	EM18409	O-RING
2	EM20763	FUEL FILTER
2	EM20328TKIT	BEARING KIT
1	EM28004DD	REDUCER 3" X 2"
1	EM23946	3" ELBOW
2	EM28904	3" CLAMP
4	EM289041	3" GASKETS
1	EM14159	HOPPER SCREEN
8	22401M7714	SPARK PLUG
4	1520855400	ELEMENT, OIL
1	11920H9915	V-BELT, GOVERNOR
1	2215723G15	ROTOR ASSY, ENGINE
1	2211577A11	SIGNAL ROTOR SET
1	22020G5111	TRANSISTOR-IGN UNIT
1	22023G5110	SEAT-SYNK
1	2216278A10	CAP ASSY, DIST. W/POINT ASSY
1	1172077702	V-BELT, FAN

C-30HDNI CONCRETE PUMP W/ PRECISION FUEL INJECTION SYSTEM 3 Units

QTY.	P/N	DESCRIPTION
10	EM14904	PISTON CUP KITS
10	EM18804	4 1/2" STEEL
10	EM14818	4" STEEL BALL
12	EM14903	BALL STOP PIN KITS
25	EM18801	MANIFOLD O-RINGS
3	EM14308	CHAINS
10	EM26313	HALF LINK
10	EM26314	MASTER LINK
2	EM14334	COMPENSATOR SPRING
4	EM14408	BRONZE RING
2	EM903092	CAM ROLLER BEARING
6	EM14315	V-BELT
6	EM14842	LOWER SEAT
6	EM14843	UPPER SEAT
3	EM26310	CLUTCH LINING
20	EM18409	O-RING
6	EM20763	FUEL FILTER
2	EM20328TKIT	BEARING KIT
2	EM28004DD	REDUCER 3" x 2"
2	EM23946	3" ELBOW
4	EM28904	3" CLAMP
10	EM289041	3" GASKET
2	EM14159	HOPPER SCREEN
1	EM14300	CAM
1	EM14801	T-MANIFOLD
1	EM14819	Y-MANIFOLD
2	EM14335	PISTON ROD
1	EM26788	REMOTE SWITCH
1	EM903176	CONN. ROD BEARING
1	EM14305	CRANKSHAFT
2	EM14807	PUMP CYLINDER
2	EM18800	COMPENSATOR CYLINDER
1	EM14320	CLUTCH
24	22401M7714	SPARK PLUG
12	1520855400	ELEMENT, OIL
3	11920H9915	V-BELT, GOVERNOR
3	2215723G15	ROTOR ASSY, ENGINE
3	2211577A11	SIGNAL ROTOR SET
3	22020G5111	TRANSISTOR-IGN UNIT
3	22023G5110	SEAT-SYNK
3	2216278A10	CAP ASSY, DIST. W/POINT ASSY
3	1172077702	V-BELT, FAN

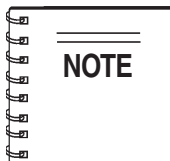

Part number on this Suggested Spare Parts List may super cede/replace the P/N shown in the text pages of this book.

C-30HDNI (PRECISION) PUMP — NAMEPLATE AND DECALS

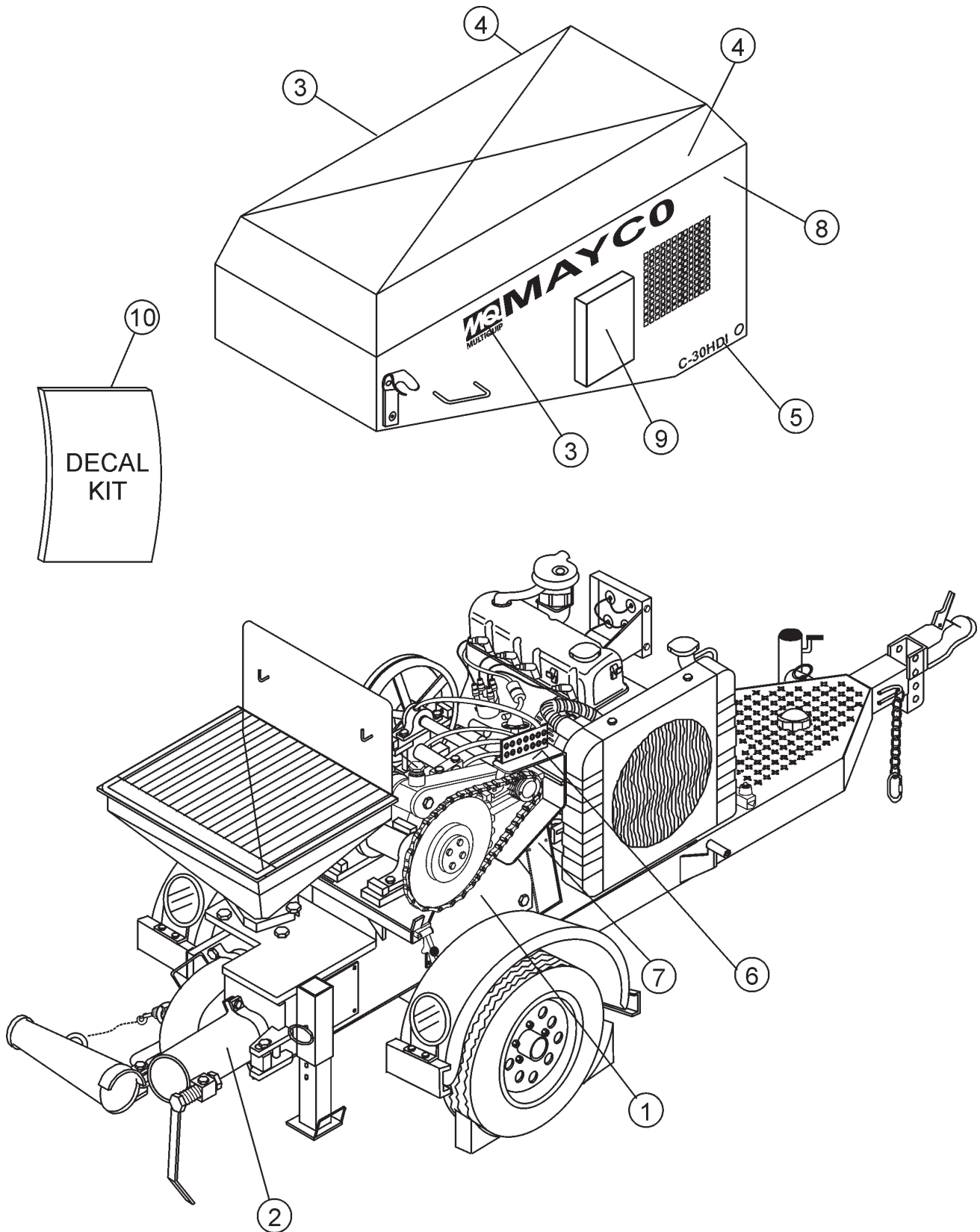

C-30HDNI (PRECISION) PUMP — NAMEPLATE AND DECALS

NAME PLATE AND DECALS

<u>NO</u>	<u>PART NO</u>	<u>PART NAME</u>	<u>QTY.</u>	<u>REMARKS</u>
1*	DCL152	DECAL, CAUTION OIL LEVEL	1	
2*	EM932	DECAL, CAUTION, MANIFOLD	1	
3*	EM1028	DECAL, MULTIQUIP MAYCO	2	
4*	508594	DECAL, CAUTION READ MANUAL	2	
5*	TBD	DECAL, C-30HDNI	2	
6*	EM513165	DECAL, MAINTENANCE	1	
7		DECAL, NAME PLATE	1 CONTACT PARTS DEPT.
8*	98022	DECAL, WARNING	1	
9*	34536	DECAL, OWNER'S MANUAL	1	
10	DCLC30HDNIKIT	KIT, DECAL	1 INCLUDES ITEMS W/ *

C-30HDNI PUMP — COMPENSATOR PISTON ROD ASSY.

COMPENSATOR PISTON ROD ASSY.

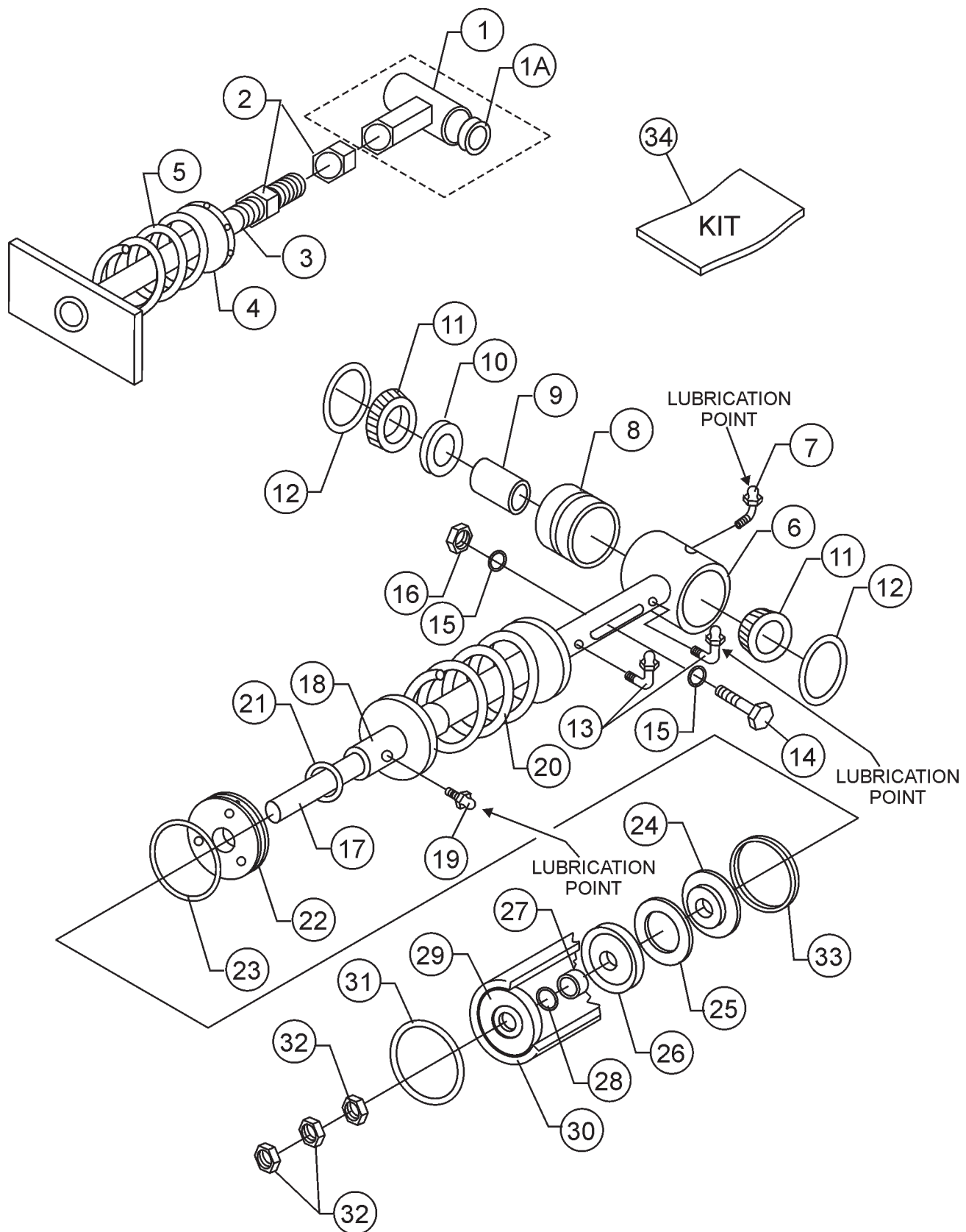

C-30HDNI PUMP — COMPENSATOR PISTON ROD ASSY.

COMPENSATOR PISTON ROD ASSY.

<u>NO.</u>	<u>PART NO.</u>	<u>PART NAME</u>	<u>QTY.</u>	<u>REMARKS</u>
1	EM14805	ROD END	1	INCLUDES ITEMS W/+
1A+	EM148053	BUSHING	1	
2	EM968446	NUT HEX, 3/4"-10 GR5	2	
3	EM14332	ROD SPRING GUIDE 3/4"	1	
4	EM14331	SPRING BACKING PLATE	1	
5	EM14333	SPRING RETURN	1	
6	EM14806	PISTON GUIDE ASSY.	1	
7	EM505490	FITTING	1	
8*	EM903163	BEARING CUP	1	
9*	EM20814	BEARING BUSHING	1	
10*	EM20813	SPACER	1	
11*	EM903162	BEARING CONE	2	
12*	EM20816	O-RING	2	
13	EM916001	FITTING	2	
14	EM510266	SCREW, HHC 1/2-13X3	1	
15	EM621	WASHER	2	
16	492584	NUT LOCK 1/2" DIA.	1	
17	EM14335	PISTON ROD	1	
18	EM14336	PISTON GUIDE	1	
19	EM505489	FITTING	1	
20	EM14334	COMPENSATOR SPRING	1	
21	EM18409	O-RING	1	
22	EM98032	PLATE, OILER	1	
23	EM14407	O-RING, OILER PLATE	1	
24	EM14410	RING & FELT HOLDER	1	
25	EM14408	BRONZE RING	1	
26	EM14411	PISTON CUP-BLACK	1	
26	EM98051	PISTON CUP-ORANGE	1	
27	EM14412	BUSHING 1 1/4 CRS	1	
28	EM18409	O-RING 1"	2	
29	EM14413	FACE PLATE	1	
30	EM18800HD	PUMPING CYLINDER	1	2-1/2" LIP SLEEVE
31	EM26525	O-RING, CYLINDER BOX	1	
32	EM968446	NUT HEX, 3/4-10	3	
33	EM16493	FELT RING	1	
34	EM148053	BUSHING	1	
35	EM20328TKIT	BEARING KIT	1	INCLUDES ITEMS W/*

C-30HDN PUMP — CONNECTING ROD - DRIVE SIDE ASSY.

CONNECTING ROD - DRIVE SIDE ASSY.

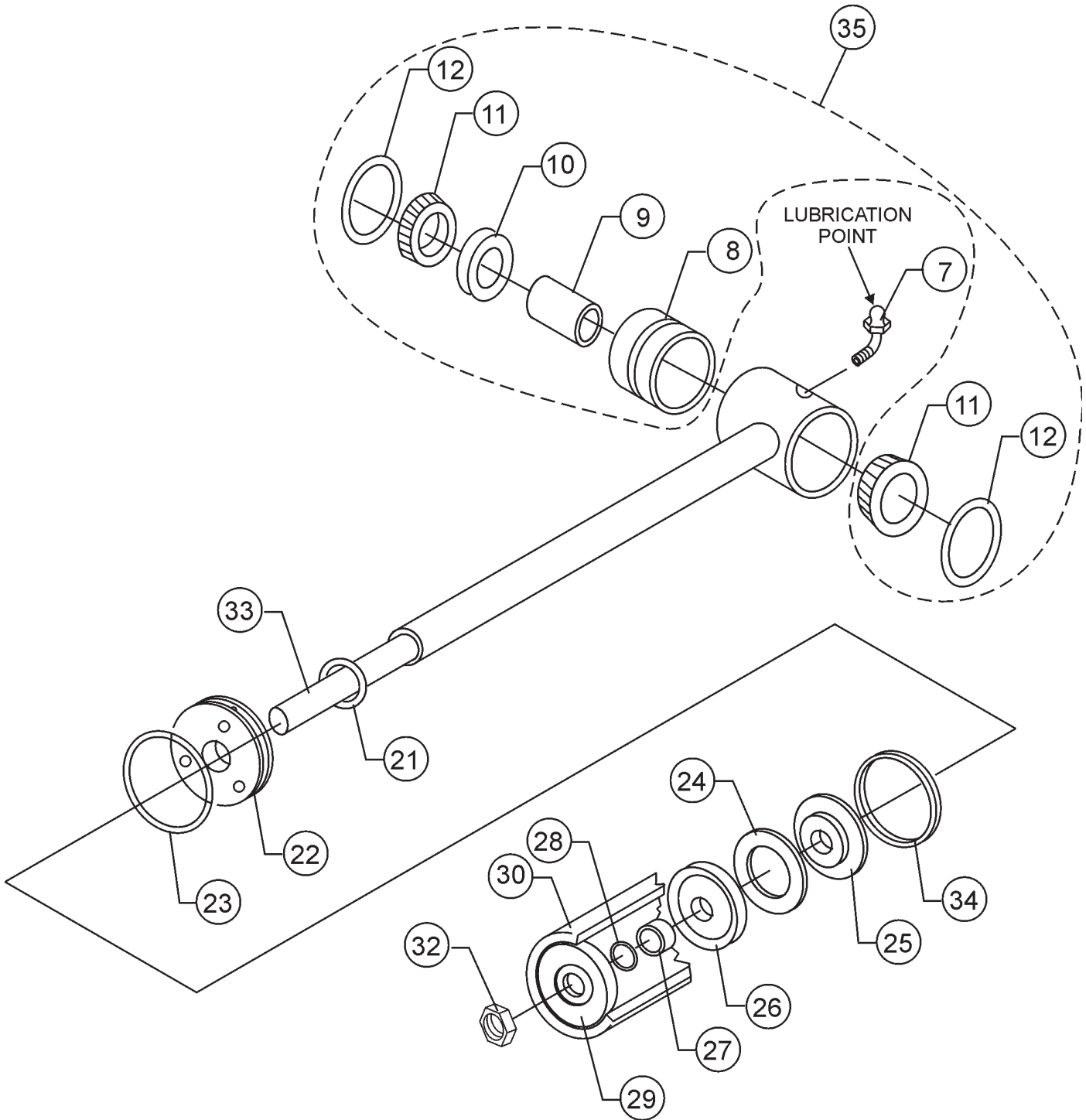

C-30HDN PUMP — CONNECTING ROD - DRIVE SIDE ASSY.

CONNECTING ROD - DRIVE SIDE ASSY.

<u>NO.</u>	<u>PART NO.</u>	<u>PART NAME</u>	<u>QTY.</u>	<u>REMARKS</u>
7	EM505490	FITTING	1	
8*	EM903163	BEARING CUP	1	
9*	EM20814	BEARING BUSHING	1	
10*	EM20813	SPACER	1	
11*	EM903162	BEARING CONE	2	
12*	EM20816	O-RING	2	
21	EM18409	O-RING	1	
22	EM98032	PLATE, OILER	1	
23	EM14407	O-RING, OILER PLATE	1	
24	EM14408	BRONZE RING	1	
25	EM14410	RING AND FELT HOLDER	1	
26	EM14411	PISTON CUP-BLACK	1	
26	EM98051	PISTON CUP-ORANGE	1	
27	EM14412	BUSHING 1 1/4 CRS	1	
28	EM18409	O-RING 1"	2	
29	EM14413	FACE PLATE	1	
30	EM14807HD	CONCRETE CYLINDER	1 3-3/4 IN. LIP SLEEVE
32	EM968446	NUT HEX, 3/4-10	3	
33	EM14808	PISTON ROD ASSY.	1	
34	EM16493	FELT RING	1	
35	EM20328TKIT	BEARING KIT	1 INCLUDES ITEMS W/*

C-30HDNI (PRECISION) PUMP — ROCKER ASSY.

ROCKER ASSY.

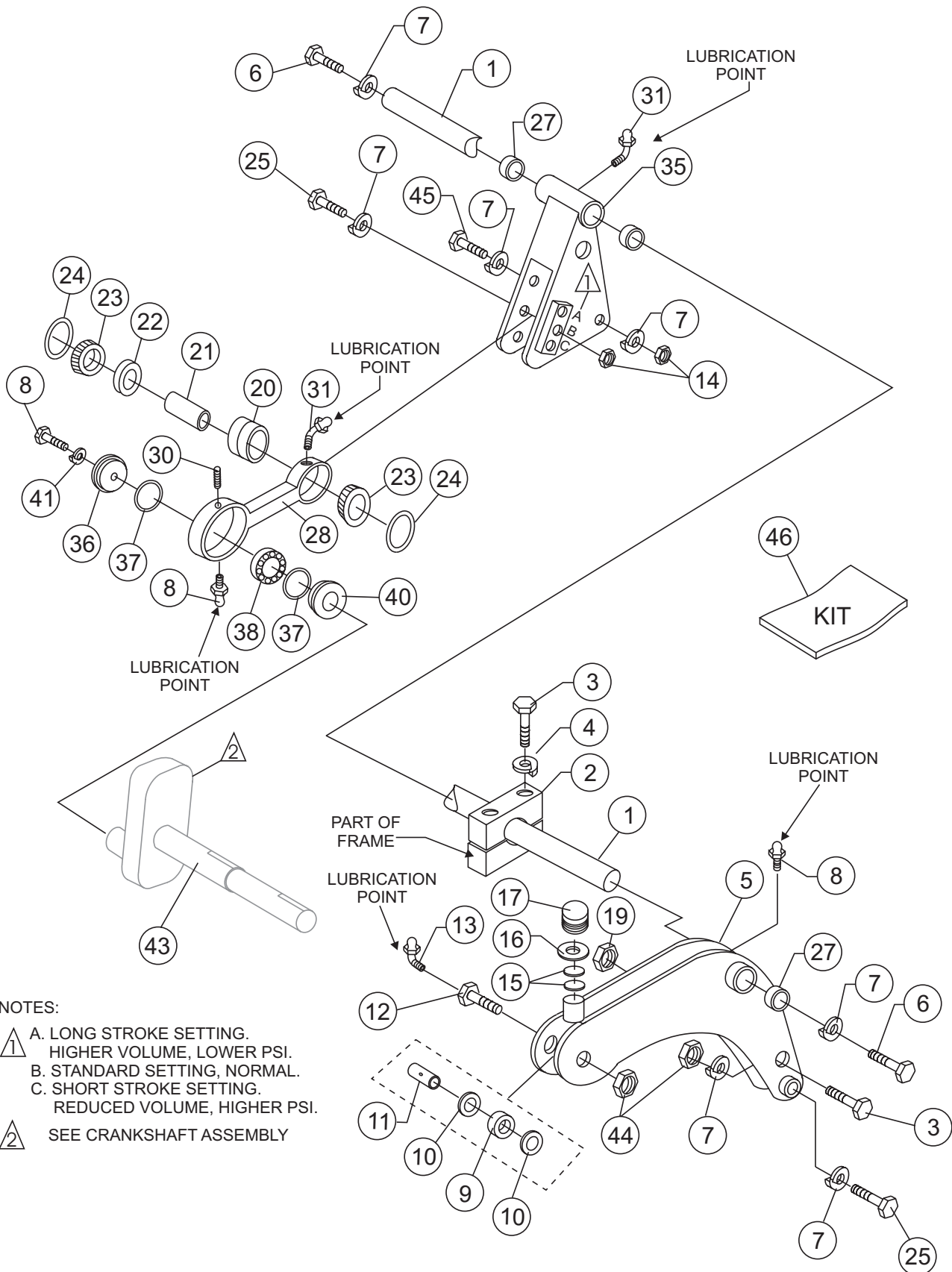

NOTES:

- ▲ A. LONG STROKE SETTING.
HIGHER VOLUME, LOWER PSI.
- B. STANDARD SETTING, NORMAL.
- C. SHORT STROKE SETTING.
REDUCED VOLUME, HIGHER PSI.
- ▲ SEE CRANKSHAFT ASSEMBLY

C-30HDNI (PRECISION) PUMP — ROCKER ASSY.

ROCKER ASSY.

<u>NO.</u>	<u>PART NO.</u>	<u>PART NAME</u>	<u>QTY.</u>	<u>REMARKS</u>
1	EM14329	SHAFT ROCKER ARM	1	
2	EM14116	JOURNAL BLOCK	1	
3	EM963180	SCREW, HHC 3/4"-10X5	2	
4	EM923350	WASHER LOCK 3/4" SPRING STEEL	2	
5	EM14846	CAM ROCKER ARM	1	INCLUDES ITEMS W/+
6	EM133	BOLT 1"-14X2" HEX HEAD	1	
7	EM603	WASHER 1" LOCK	1	
8	EM916001	ZERK FITTING	1	
9	EM903092	BEARING ASSY.	1	
10	EM20347	BEARING SPACER	2	
11	EM402434	BEARING BUSHING	1	
12	EM20344	SPECIAL BOLT	1	
13	EM916001	ZERK FITTING	1	
14	EM417	NUT FLEX LOCK	1	
15	EM402456	OILER FELT	2	
16	EM607	WASHER, FLAT 5/8"	1	
17	EM20349	OILER PLUG, PLASTIC	1	
19	EM969038	NUT STOP REG. 3/4"-10	1	
20%	EM903163	BEARING CUP	1	
21%	EM20814	BEARING BUSHING	1	
22%	EM20813	SPACER	1	
23%	EM903162	BEARING CONE	2	
24%	EM20816	O-RING	2	
25	EM105	BOLT 1"-14X6" HEX HEAD	1	
27#+	EM203262	BRONZE BUSHING	4	
28	EM20364	CONNECTING ROD	1	
30	EM702	SCREW ALLEN HEAD 3/8"-16X3/4"	1	
31	EM505490	ZERK FITTING	1	
35	EM14328	ROCKER ARM ASSY.	1	INCLUDES ITEM W/#
36	EM20338	SPACER	1	
37	EM20336	O-RING	1	
38	EM903176	BEARING	1	
40	EM402996	SEAL PLATE	1	
41	EM923348	WASHER LOCK 5/8	1	
42	EM503982	BOLT 1/2-13X5	1	
43	EM98043	FORGED CRANKSHAFT	1	INCLUDES ITEM W/*
44	EM405	NUT, LOCK 3/4"-10	2	
45	EM202	BOLT, HEX 1-8 X 6 LG.	1	
46	EM20328TKIT	BEARING KIT	1	INCLUDES ITEMS W/%

C-30HDNI (PRECISION) PUMP — COUNTER-SHAFT ASSY.

COUNTERSHAFT ASSY.

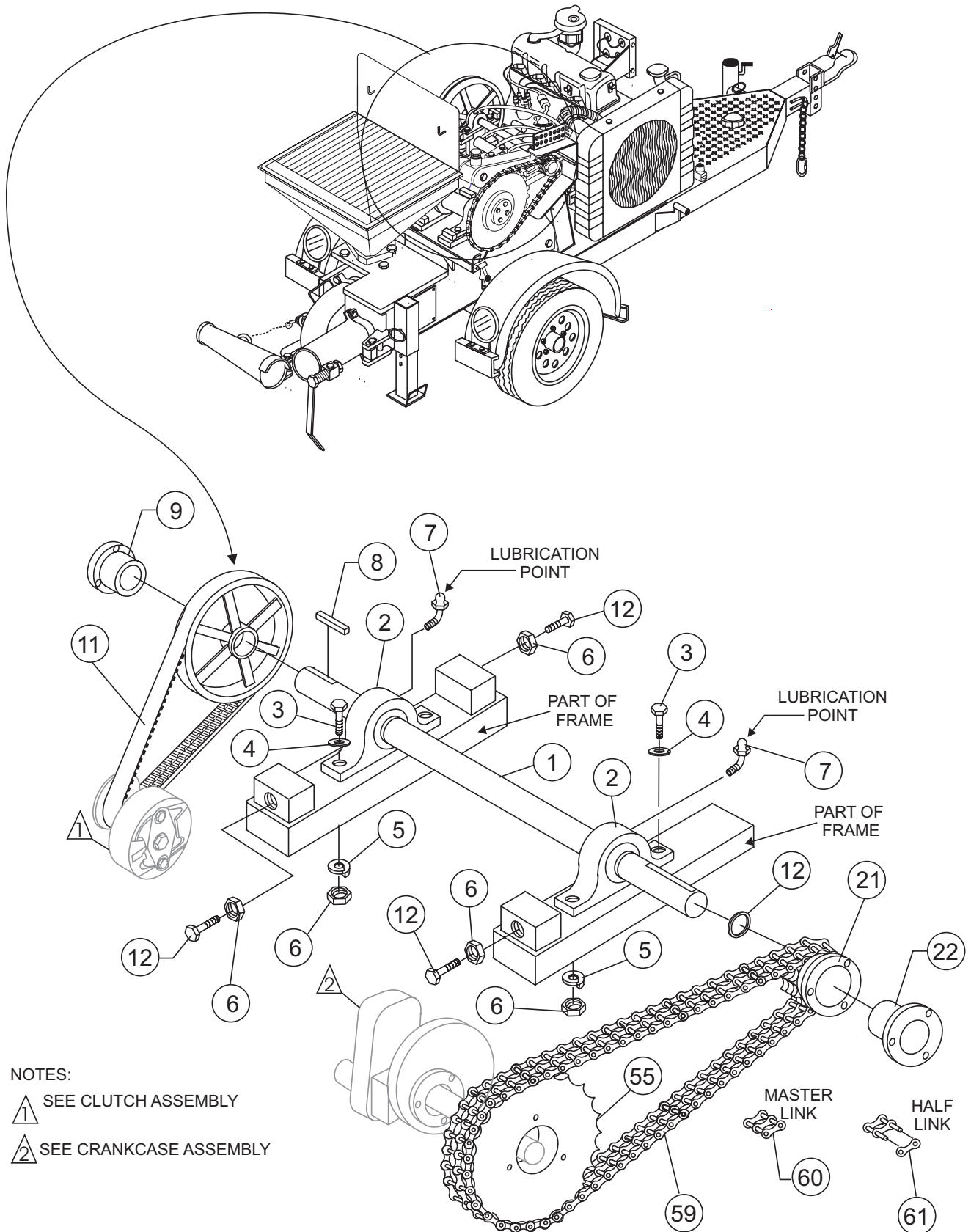

C-30HDNI (PRECISION) PUMP — COUNTER-SHAFT ASSY.

COUNTER-SHAFT ASSY.

<u>NO.</u>	<u>PART NO.</u>	<u>PART NAME</u>	<u>QTY.</u>	<u>REMARKS</u>
1	EM513073	COUNTER SHAFT	1	
2	EM14311	CAM BEARING	2	
3	EM124	BOLT HEX 1/2 X 1-3/4	2	
4	EM1621	WASHER 5"	2	
5	EM923346	WASHER, LOCK1/2"	2	
6	EM968011	NUT HEX, 1/2-13	2	
7	EM916001	FITTING	1	
8	EM14316	KEY WAY 3/8"X2.5"	1	
9	EM14314	BUSHING, PULLEY	1	
10	EM14313	PULLEY	1	
11	EM98089	BELT, DOUBLE 83 INCHES	1	
12	EM143111	SET COLLAR	1	
21	EM14318	SPROCKET, 13 TOOTH	1	
22	EM14319	BUSHING	1	
55	EM14307	SPROCKET 60 TEETH	1	
56	EM14309	BUSHING	1	
57	EM1702	SCREW ALLEN HEAD 3/8"-16X3/4"	1	
58	EM703	SET SCREW 3/8"-16X3/8"	1	
59	EM14308	CHAIN W/MASTER LINK	1	
60	EM26314	LINK MASTER	1	
61	EM26313	HALF LINK	1	

C-30HDNI (PRECISION) PUMP — CRANKSHAFT ASSY.

CRANKSHAFT ASSY.

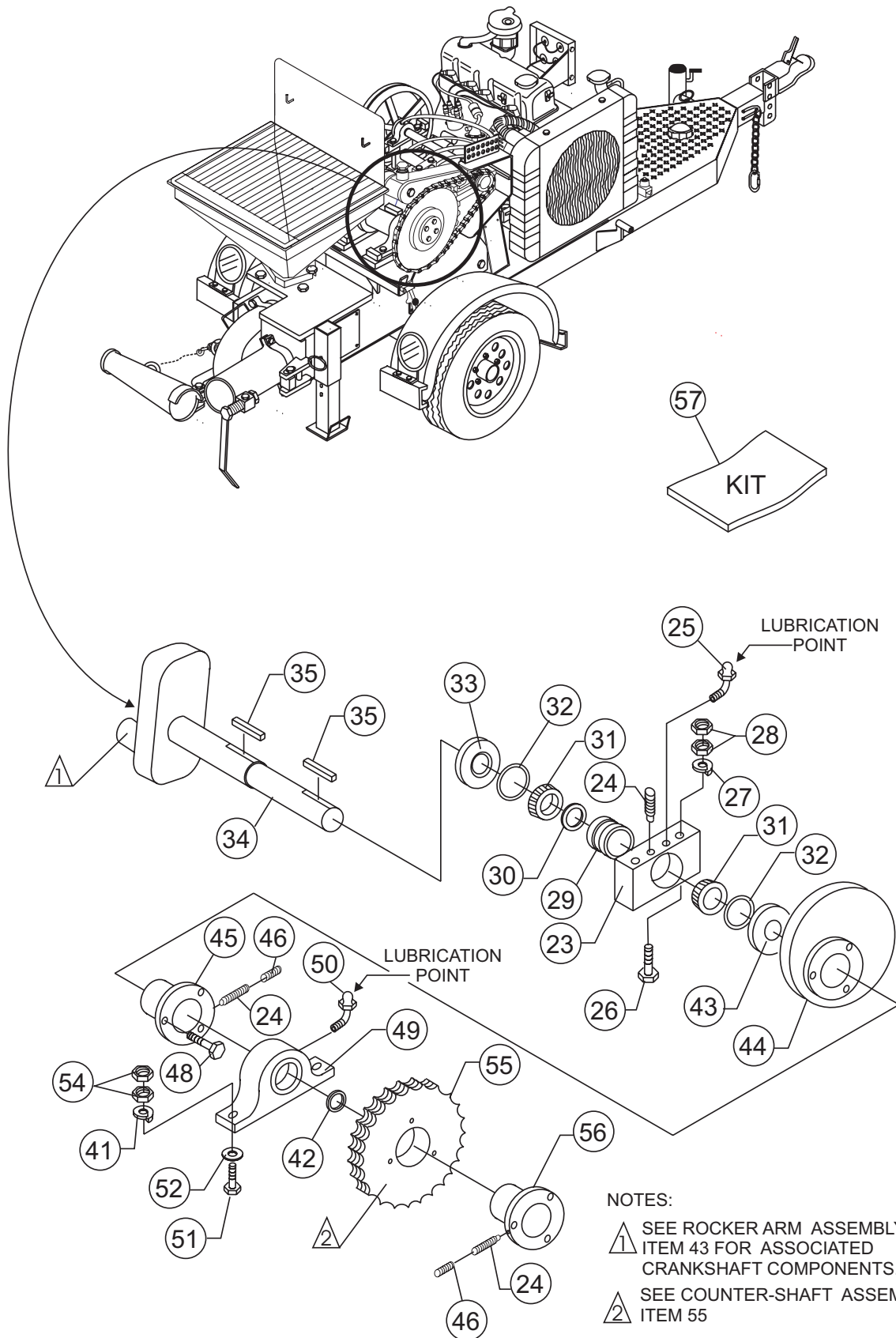

NOTES:

- ⚠ SEE ROCKER ARM ASSEMBLY ITEM 43 FOR ASSOCIATED CRANKSHAFT COMPONENTS.
- ② SEE COUNTER-SHAFT ASSEMBLY, ITEM 55

C-30HDNI (PRECISION) PUMP — CRANKSHAFT ASSY.

CRANKSHAFT ASSY.

<u>NO.</u>	<u>PART NO.</u>	<u>PART NAME</u>	<u>QTY.</u>	<u>REMARKS</u>
23*	EM14303	BEARING BLOCK	1	
24*	EM702	SCREW, ALLEN HEAD 3/8-16X3/4	6	
25	EM505490	ZERK FITTING	1	
26	EM129	SCREW, HHC 3/4-10X8-1/2	2	
27	EM492628	LOCK WASHER 3/4	2	
28	EM968446	NUT HEX, 3/4-10 GR5	4	
29*	EM14324	CUP BEARING	1	
30*	EM14323	SPACER BEARING CONE	1	
31*	EM14325	CONE BEARING	2	
32*	EM14326	O-RING	2	
33*	EM14322	SPACER	1	
34*	EM98043	CRANKSHAFT, FORGED	1	
35*	EM14306	KEY CRANKSHAFT	2	
38	EM903176	BEARING	1	
40	EM402996	SEAL PLATE	1	
41	EM923348	WASHER, LOCK 5/8"	2	
42	EM30139	SET COLLAR	1	
43*	EM14302	SPACER, CAM BUSHING	1	
44*	EM14300	CAM ASSY.	1	
45*	EM14301	BUSHING, CAM	1	
46*	EM703	SCREW ALLEN HEAD 3/8-16X3/8	6	
48*	EM175	BOLT 3/8-16X1-1/4	6	
49*	EM14304	BEARING-CAM COMPLETE	1	
50*	EM916001	ZERK FITTING	1	
51	EM128	BOLT 5/8-11X4" HEX HEAD	2	
52	EM505882	WASHER, SPECIAL 5/8"	2	
54	EM968013	NUT HEX 5/8-11	4	
55*	EM14307	SPROCKET 60 TEETH	1	
56*	EM14309	BUSHING	1	
57	EM98043K	CRANKSHAFT FORGE ASSEMBLY	1	INCLUDES ITEM W/*

C-30HDNI (PRECISION) PUMP — MANIFOLD ASSY.

MANIFOLD ASSY.

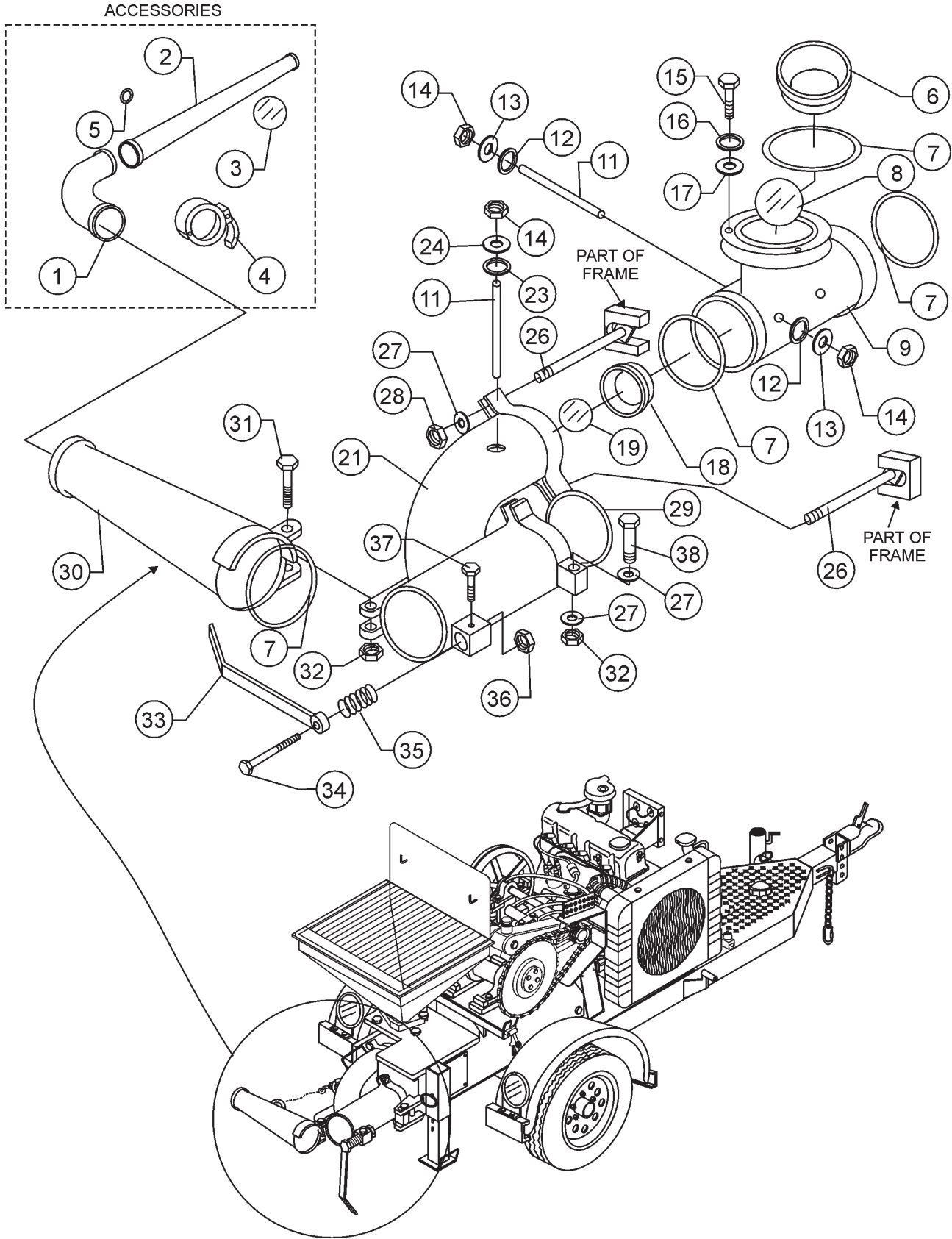

C-30HDNI (PRECISION) PUMP — MANIFOLD ASSY.

MANIFOLD ASSY.

<u>NO.</u>	<u>PART NO.</u>	<u>PART NAME</u>	<u>QTY.</u>	<u>REMARKS</u>
1	EM23946	ELBOW 3"X90 DEG.HD	1	
2	EM28004DD	REDUCER 3X2X36 HD	1	
3	EM2C0B	BALL 2" SPONGE	2	
4	EM28904	COUPLING 3" HD *CF*	2	
5	EM18409	O-RING 1"	4	
6	EM14843	UPPER DURASEAT	1	
7	EM18801	O-RING	6	
8	EM18804	BALL 4-1/2"	1	
9	EM14801	MANIFOLD T ASSY.	1	
11	EM136	PIN BALL STOP 3/4-16 x 8	3	
12	EM18409	O-RING	4	
13	EM618	WASHER SPECIAL	4	
14	EM968266	NUT JAM HEX 3/4-16	4	
15	EM104	BOLT 5/8-11X2" HEX HEAD	3	
16	EM923348	WASHER LOCK 5/8 SPRING	3	
17	EM505882	WASHER, 5/8	3	
18	EM14842	SEAT DURA LOWER	1	
19	EM14818	BALL 4"	1	
21	EM14819A	MANIFOLD ASSY. EASY OPEN	1	
23	EM18409	O-RING	2	
24	EM618	WASHER SPECIAL	2	
26	EM137	TEE-BOLT 3/4-10X14"	2	
27	EM619	WASHER 3/4"	2	
28	EM968446	NUT HEX 3/4"-10 GR5	2	
30	EM14850	EXHAUST GATE "H/D"	1	
31	EM963180	CAPSCREW 3/4-10X5 HEX HD G8	1	
32	EM969038	NUT STOP REG.3/4-10	2	
33	EM14845	ARM CLAMP	1	
34	EM135	BOLT 1-1/4" -12X7" HEX HD.	1	
35	EM14810	SPRING	1	
36	EM451	NUT 1-1/4" -12 LOCK	1	
37	EM160	BOLT 3/8-16X3/4"	1	
38	EM509329	SCREW HHC 3/4-10X6	1	

C-30HDNI (PRECISION) PUMP — FRAME ASSY.

FRAME ASSY.

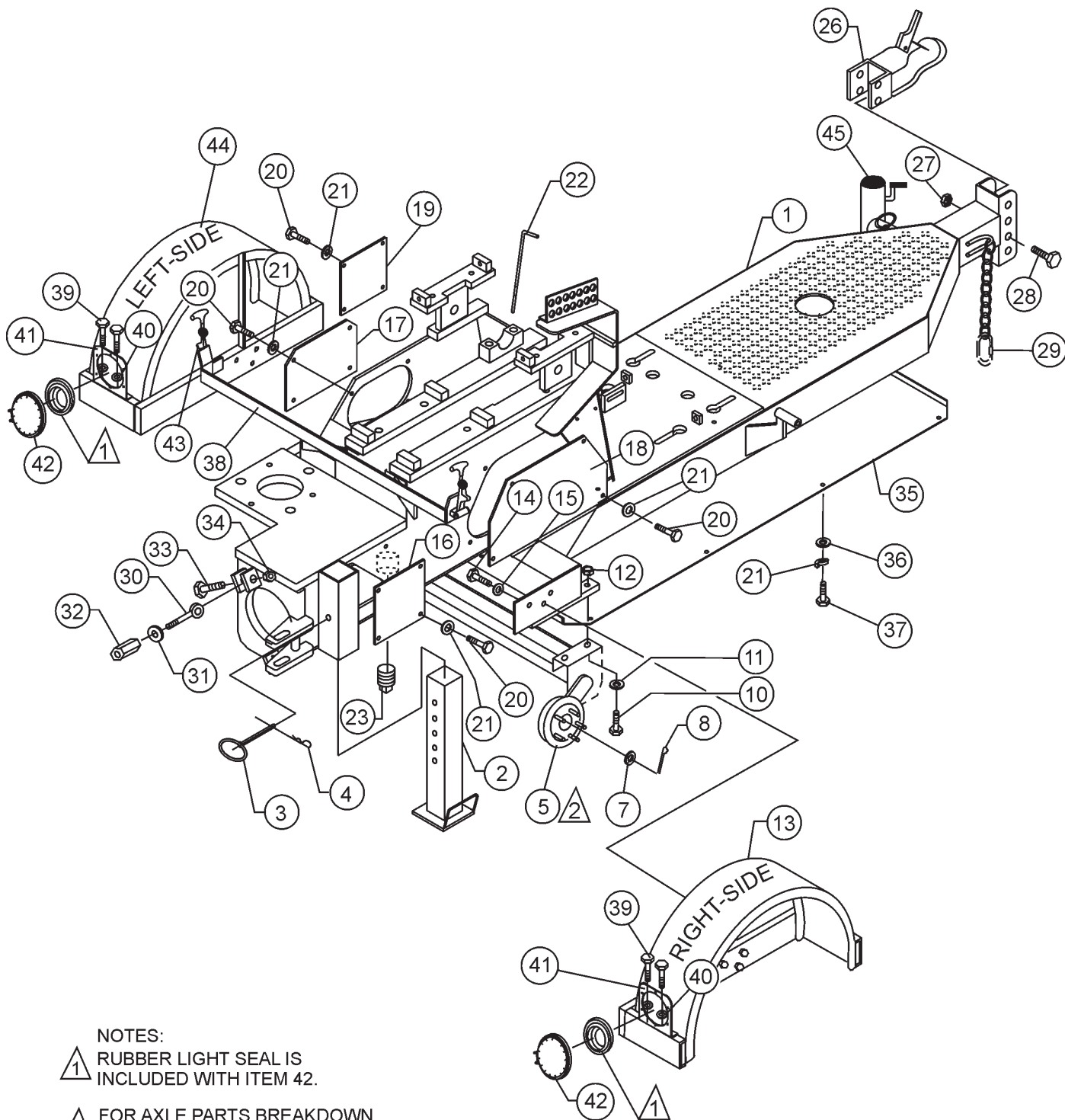

NOTES:

- 1 RUBBER LIGHT SEAL IS INCLUDED WITH ITEM 42.
- 2 FOR AXLE PARTS BREAKDOWN SEE AXLE ASSEMBLY

C-30HDNI (PRECISION) PUMP — FRAME ASSY.

FRAME ASSY.

<u>NO.</u>	<u>PART NO.</u>	<u>PART NAME</u>	<u>QTY.</u>	<u>REMARKS</u>
1	EM513085	FRAME ASSEMBLY	1	
2	EM70186	JACK STAND, REAR	1	
3	EM744	CLEVIS PIN 1/2" X 4"	1	
4	EM745	HAIR PIN C 5/8- 3/4"	1	
5	EM14600A	AXLE, ASSEMBLY	1	
7	501299	WASHER THICK 1"	2	
8	491689	KEY COTTER 1/8 X 2	2	
10	EM492396	SCREW HHC 1/2- 13 X 2	4	
11	EM621	WASHER .5"	4	
12	EM406	NUT LOCK 1/2" DIA.	4	
13	EM511418	FENDER RIGHT-SIDE	1	
14	981635	BOLT, HHC 1/2- 13 X 3/4	6	
15	6109180	WASHER LOCK 1/2"	6	
16	EM512251	COVER	1	
17	EM512252	COVER	1	
18	EM512253	COVER	1	
19	EM512250	COVER	1	
20	EM492309	SCREW, HHC	16	
21	0166 A	WASHER, LOCK 3/8"	24	
22	EM512263	ROD	1	
23	EM507895	PLUG, 2 1/2 NPT	2	
26	29228	HITCH, TONGUE 2"	1	
27	EM969023	NUT, HEX 5/8" NC	2	
28	EM507658	SCREW, HHC 5/8" NC 4-1/2 G5	2	
29	EM509947	LINK, QUICK	2	
30	EM14165	BOLT EYE	2	
31	EM619	WASHER 3/4" WILLIAM	2	
32	EM968002	NUT COUPLING 3/4- 10	2	
33	EM505121	SCREW 3/4"- 10 X 3 GR.5	2	
34	EM969038	NUT STOP REG. 3/4- 10	2	
35	EM513078	COVER, CHASSIS BOTTOM	1	
36	10136	WASHER, FLAT 3/8	8	
37	EM492264	HHCS. 3/8" NC X 1"	8	
38	EM929028	HOOD REST, STEEL	2	
39	492363	SCREW HHC 5/16- 18 X 3/4"	4	
40	EM923343	WASHER LOCK 5/16"	4	
41	EM265361	BRACKET LIGHT	2	
42	EM26536	TAIL LIGHT	2	
43	491010	HOOD FASTENER, RUBBER	2	
44	EM513087	FENDER LEFT-SIDE	1	
45	25610	JACK STAND, FRONT	1	

C-30HDNI (PRECISION) PUMP — AXLE ASSY.

AXLE ASSY.

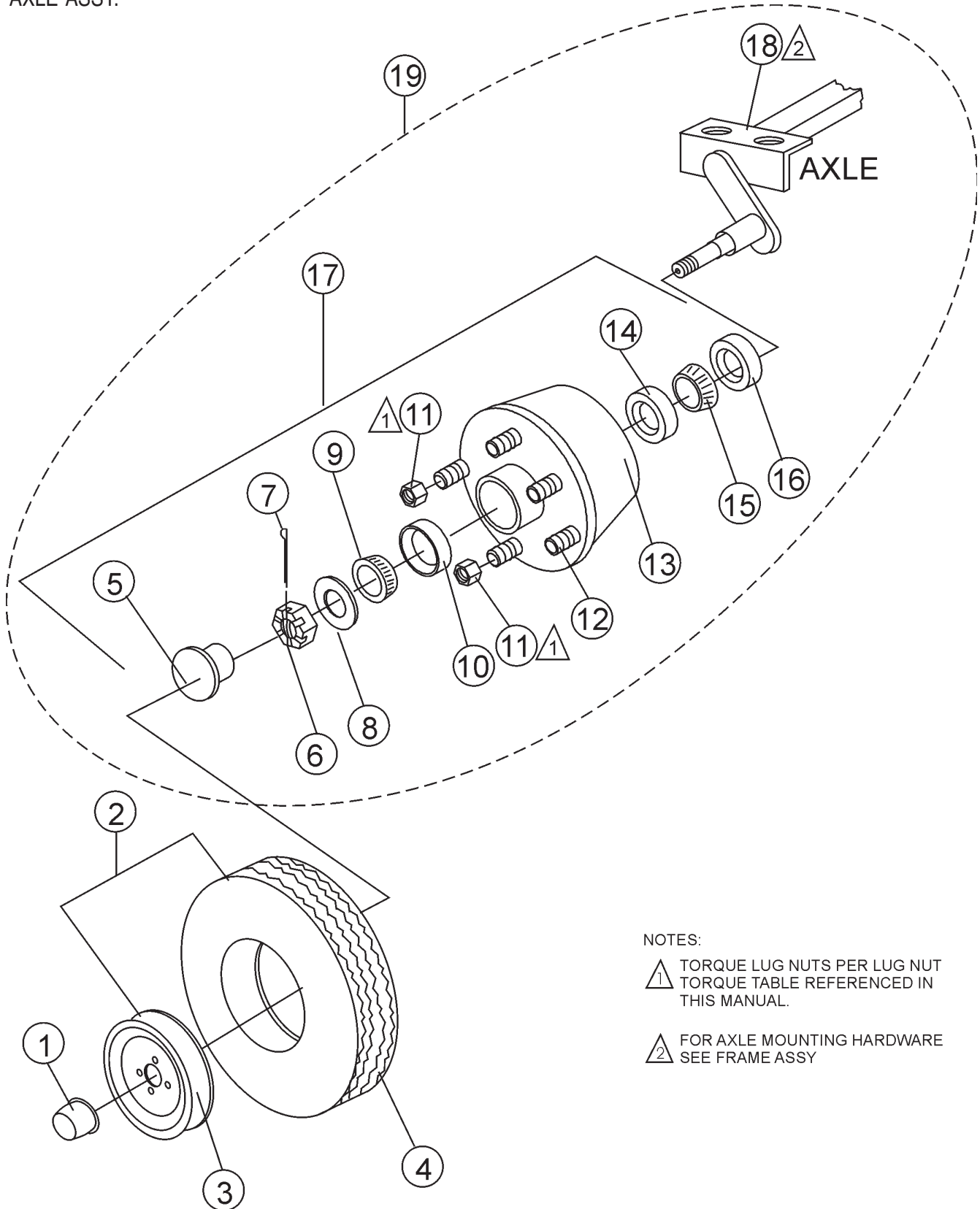

NOTES:

△ 1 TORQUE LUG NUTS PER LUG NUT TORQUE TABLE REFERENCED IN THIS MANUAL.

△ 2 FOR AXLE MOUNTING HARDWARE SEE FRAME ASSY

C-30HDNI (PRECISION) PUMP — AXLE ASSY.

AXLE ASSY.

<u>NO.</u>	<u>PART NO.</u>	<u>PART NAME</u>	<u>QTY.</u>	<u>REMARKS</u>
1	EM26518	CAP 14" CHROME	2	
2	EM26615A	TIRE ASSY.....	2	INCLUDES ITEMS W/*
3*		WHEEL	2	CANNOT BE PURCHASED SEPARATELY
4*		TIRE 14"	2	CANNOT BE PURCHASED SEPARATELY
5#	EM26306	DUST COVER	2	
6#	EM968481	CASTLE NUT	2	
7	EM705	PIN, COTTER 3/16X1 1/2	2	
8#	EM26329	WASHER	2	
9#	EM903113	OUTER BEARING	2	
10#	EM903012	OUTER CUP	2	
11#	EM26519	NUT	12	
12#	EM20612	STUD	12	
13#	EM26300	HUB	2	
14#	EM903169	INNER CUP	2	
15#	EM903168	INNER BEARING	2	
16#	EM26305	GREASE SEAL	2	
17%	EM20601	HUB ASSEMBLY	2	INCLUDES ITEMS W/#
18%	EM14600	AXLE	1	
19	EM14600A	AXLE WITH HUBS INSTALLED	1	INCLUDES ITEMS W/%

C-30HDNI PUMP — MUFFLER, AIR FILTER, AND STOP SWITCH ASSY.

MUFFLER, AIR FILTER AND STOP SWITCH ASSY.

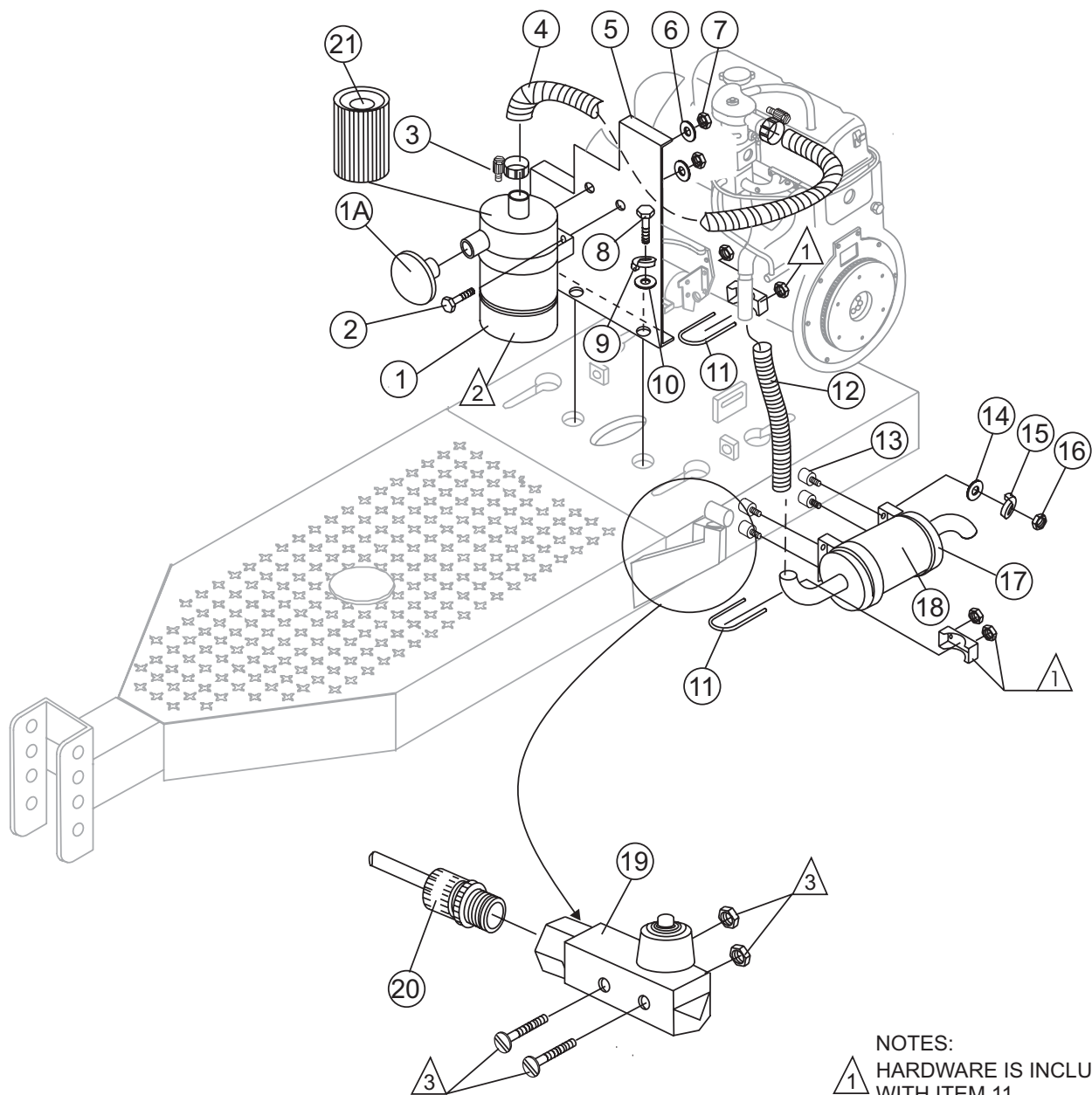

NOTES:

- ① HARDWARE IS INCLUDED WITH ITEM 11.
- ② AIR FILTER SUPPORT BRACKET IS INCLUDED WITH ITEM 1.
- ③ STOP SWITCH MOUNTING HARDWARE IS INCLUDED WITH ITEM 19.

C-30HDNI PUMP — MUFFLER, AIR FILTER, AND STOP SWITCH ASSY.

MUFFLER, AIR FILTER AND STOP SWITCH ASSY.

<u>NO.</u>	<u>PART NO.</u>	<u>PART NAME</u>	<u>QTY.</u>	<u>REMARKS</u>
1	EM98076	FILTER, AIR	1	
1A	EM98168	PRECLEANER, AIR FILTER	1	
2	492364	SCREW, HHC 5/16- 18 X 1	2	
3	EM513126	CLAMP, AIR INTAKE	2	
4	EM513102	FLEX HOSE, AIR CLEANER	1	17.5" LENGTH 1-3/4 DIA.
5	EM513106	PANEL, FILTER SUPPORT	1	
6	EM492897	WASHER, FLAT 5/16	2	
7	492582	NUT, NYLOC 5/16- 18	2	
8	EM963610	HHCS 3/8 X1 G5	2	
9	0166A	WASHER, LOCK	2	
10	3019092	WASHER, FLAT	2	
11	506257	U-BOLT	2	
12	EM513111	FLEX TUBING, MUFFLER	1	10" LENGTH 1-1/2 DIA.
13	EM513110	BUSHING, 1/4- 20 RUBBER MUFFLER	4	
14	EM923057	WASHER, FLAT 1/4"	2	
15	2101402	WASHER, LOCK 1/4"	2	
16	TBD	NUT	4	
17	EM98078	CLAMP, 6" MUFFLER	2	
18	EM98077	MUFFLER	1	
19	EM14217	STOP SWITCH, ENGINE COVER	1	
20	EM491873	GLAND CONNECTOR	1	
21	ZE1	ELEMENT, AIR FILTER	1	

C-30HDNI (PRECISION) PUMP — CLUTCH ASSY.

CLUTCH ASSY.

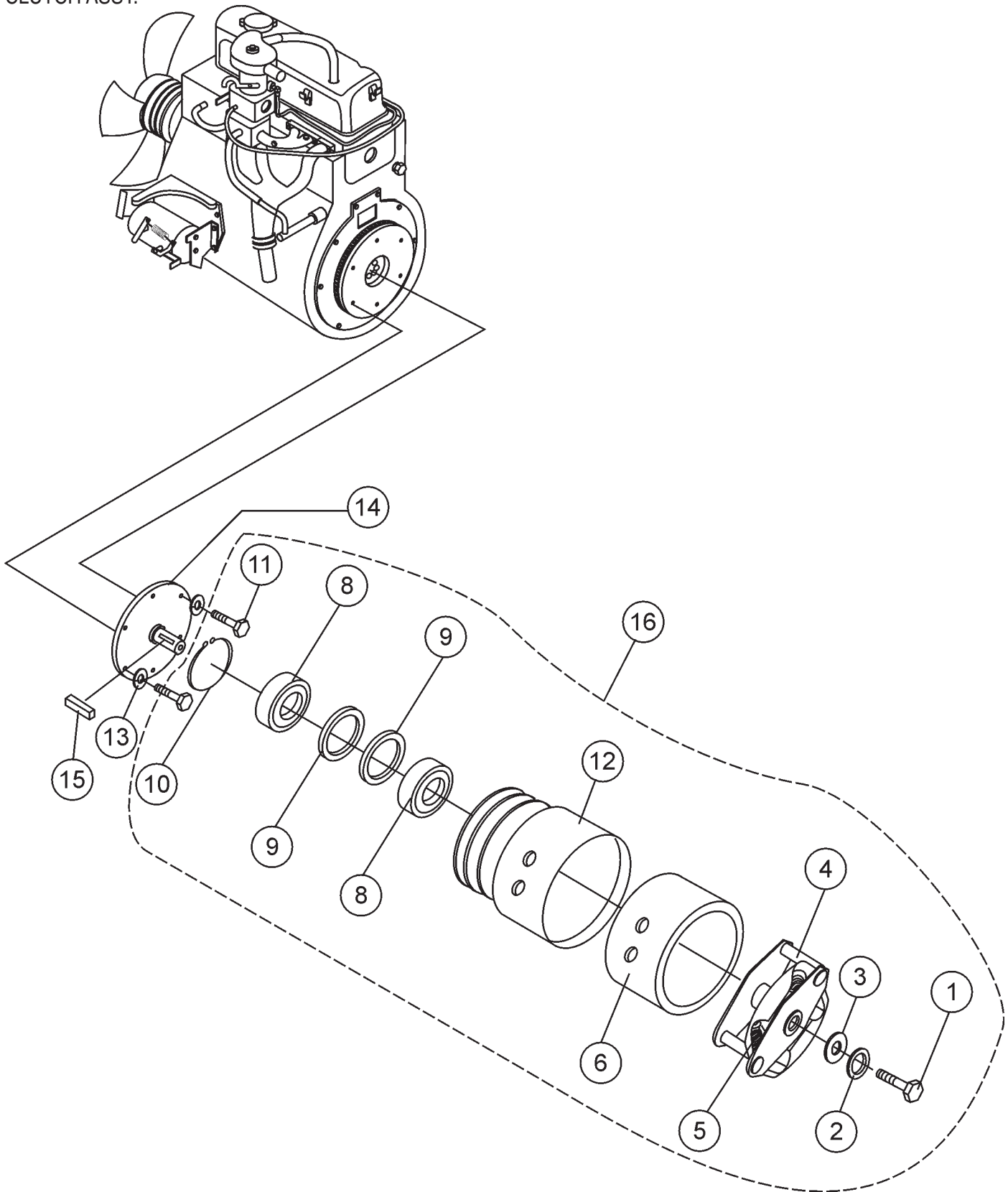

C-30HDNI (PRECISION) PUMP — CLUTCH ASSY.

CLUTCH ASSY.

<u>NO.</u>	<u>PART NO.</u>	<u>PART NAME</u>	<u>QTY.</u>	<u>REMARKS</u>
1*	492395	SCREW, HHC 1/2- 13X1-3/4"	1	
2*	EM923346	WASHER, LOCK 1/2"	1	
3*	EM621	WASHER, FLAT 1/2" SPECIAL	1	
4*	EM26321	ROTOR ASSEMBLY	1	
5*	EM918050	CLUTCH SPRING	2	
6*	EM26310	CLUTCH LINING	1	
8*	EM902204	CLUTCH BEARING	2	
9*	EM926066	RETAINING RING	2	
10*	EM926053	RETAINING RING	1	
11*	EM508342	SCREW, HHC M8X25 PI.25	6	
12*	EM26322	CLUTCH HOUSING W/LINING	1	
13	0166A	WASHER, LOCK 3/8"	6	
14	EM98071	SHAFT STUB (FLANGE), ENGINE	1	
15	EM26348	KEY	1	
16	EM14320	CLUTCH COMPLETE ASSEMBLY	1 INCLUDES ITEMS W/*

C-30HDNI PUMP — RADIATOR AND ENGINE MOUNTING BRACKET ASSY.

RADIATOR AND ENGINE MOUNTING BRACKET ASSY.

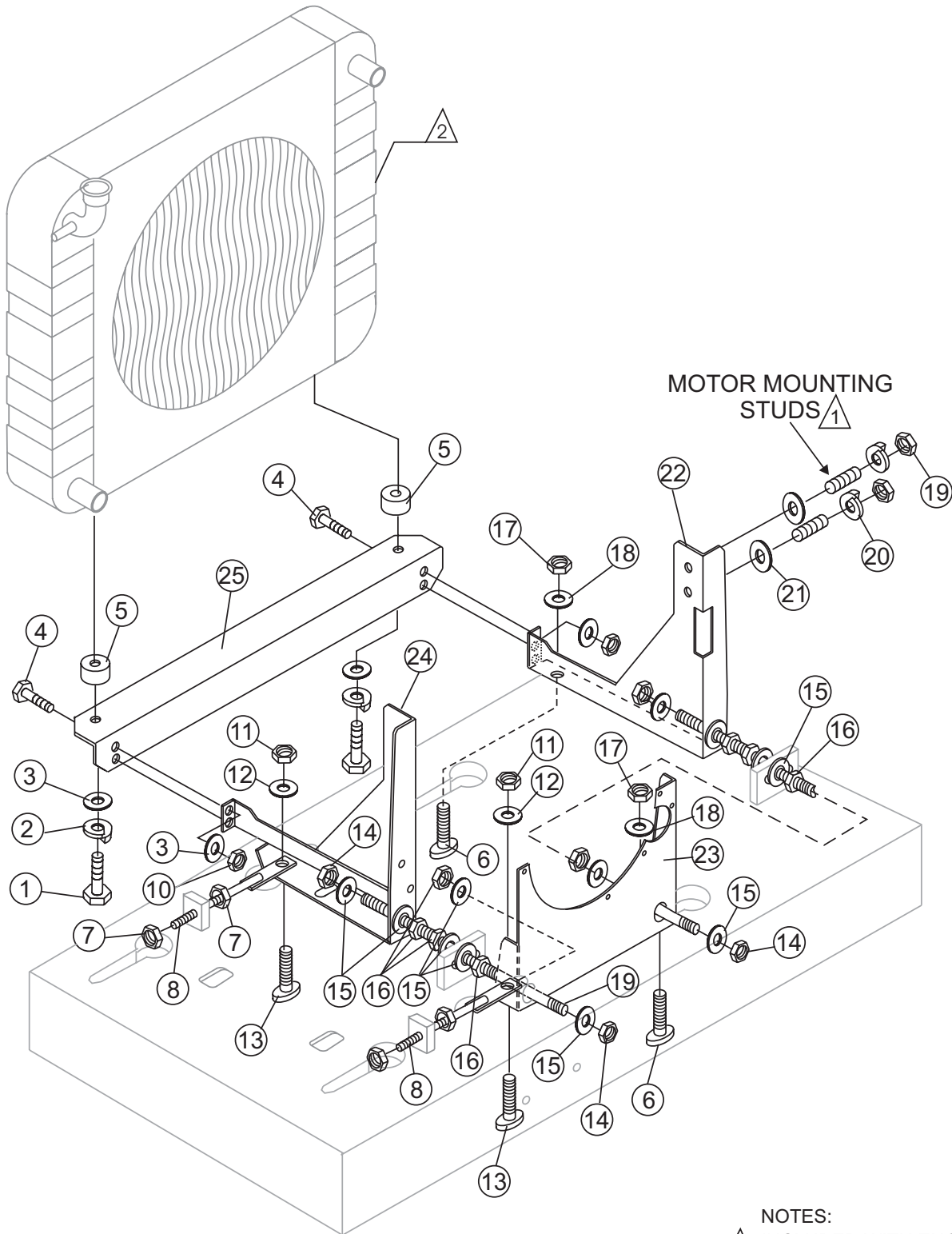

NOTES:
1 INCLUDED WITH ENGINE.

2 SEE RADIATOR ASSEMBLY

C-30HDNI PUMP — RADIATOR AND ENGINE MOUNTING BRACKET ASSY.

RADIATOR AND ENGINE MOUNTING BRACKET ASSY.

<u>NO.</u>	<u>PART NO.</u>	<u>PART NAME</u>	<u>QTY.</u>	<u>REMARKS</u>
1	EM64900014	SCREW, HHCS 3/8 - 16 x 7/8"	2	
2	EM64700071	WASHER, LOCK 3/8	2	
3	EM64700070	WASHER, FLAT .375 x .0734 x .065	6	
4	EM64900156	BOLT, HEX 5/16 - 16 x 1	4	
5	EM65500003	ISOLATOR 38 x 25, 3/8-16	2	
6	EM513094	SCREW, SQUARE 1/2- 13 x 1-3/4"	2	
7	6109160	NUT, HEX 1/2- 13	4	
8	EM513040	TENSIONER, ADJUSTMENT	2	
10	EM64800145	NUT, HEX 5/16 - 18`	4	
11	6109160	NUT, HEX 1/2- 13	2	
12	6109180	WASHER, LOCK 1/2"	2	
13	513095	SCREW, SQUARE 1/2- 13X2	2	
14	492584	NUT, NYLOC 1/2- 13	4	
15	492600	WASHER, FLAT 1/2"	12	
16	6109160	NUT, HEX 1/2- 13	8	
17	6109160	NUT, HEX 1/2- 13	2	
18	6109180	WASHER, LOCK 1/2"	2	
19	EM64800124	NUT, HEX M8-1.25	2	
20	EM94700080	WASHER, LOCK 8 MM	2	
21	EM94700079	WASHER, FLAT 8MM NARROW	2	
22	EM20200043	LEFT FRONT SUPPORT	1	
23	EM20100042	LEFT REAR SUPPORT	1	
24	EM20200042	LEFT RIGHT SUPPORT	1	
25	EM20500034	BRACKET, CROSS	1	

C-30HDNI PUMP — RADIATOR, MOUNTING BRACKET AND HOSES ASSY.

RADIATOR, BRACKET AND HOSES ASSY.

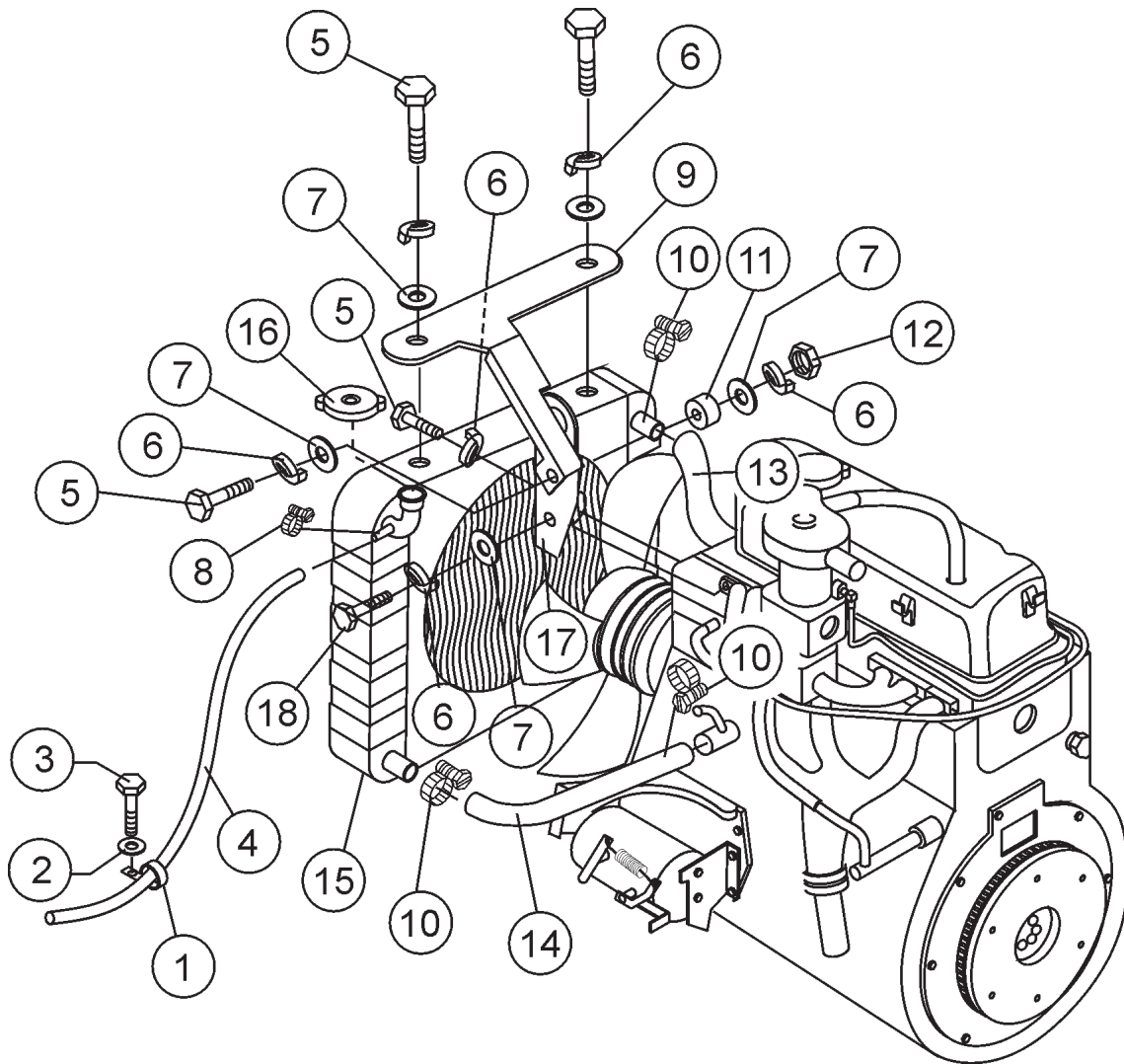

C-30HDNI PUMP — RADIATOR, MOUNTING BRACKET AND HOSES ASSY.

RADIATOR, BRACKET AND HOSES ASSY.

<u>NO.</u>	<u>PART NO.</u>	<u>PART NAME</u>	<u>QTY.</u>	<u>REMARKS</u>
1	EM513116	CLAMP, 1/2" HOSE	1	
2	2101402	WASHER, FLAT 1/4"	1	
3	492268	HHCS 1/4" x 3/4"	1	
4	EM20427	HOSE, OVERFLOW	1	
5	EM64900014	HHCS, 3/8 -16 x 7/8"	1	
6	EM94700071	WASHER, LOCK 3/8"	1	
7	EM64700070	WASHER, FLAT .375 x .0734 x .065"	1	
8	506208	CLAMP, HOSE	1	
9	EM21000092	BRACKET, UPPER RADIATOR	1	
10	EM68800003	CLAMP, HOSE WORM DRIVE	4	
11	EM65508003	ISOLATOR	1	
12	EM64800155	NUT, HEX 3/8-16	1	
13	EM98079	RADIATOR HOSE, UPPER	1	
14	EM98080	RADIATOR HOSE, LOWER	1	
15	EM98072	RADIATOR	1	
16	EM69300001	CAP, RADIATOR 13 PS1	1	
17	EM21000091	BRACKET, UPPER RADIATOR	1 ISOLATOR MOUNT
18	EM64900101	HHCS, M8-1.25 X 20	1	

C-30HDNI (PRECISION) PUMP — CONTROL BOX ASSY.

CONTROL BOX ASSY.

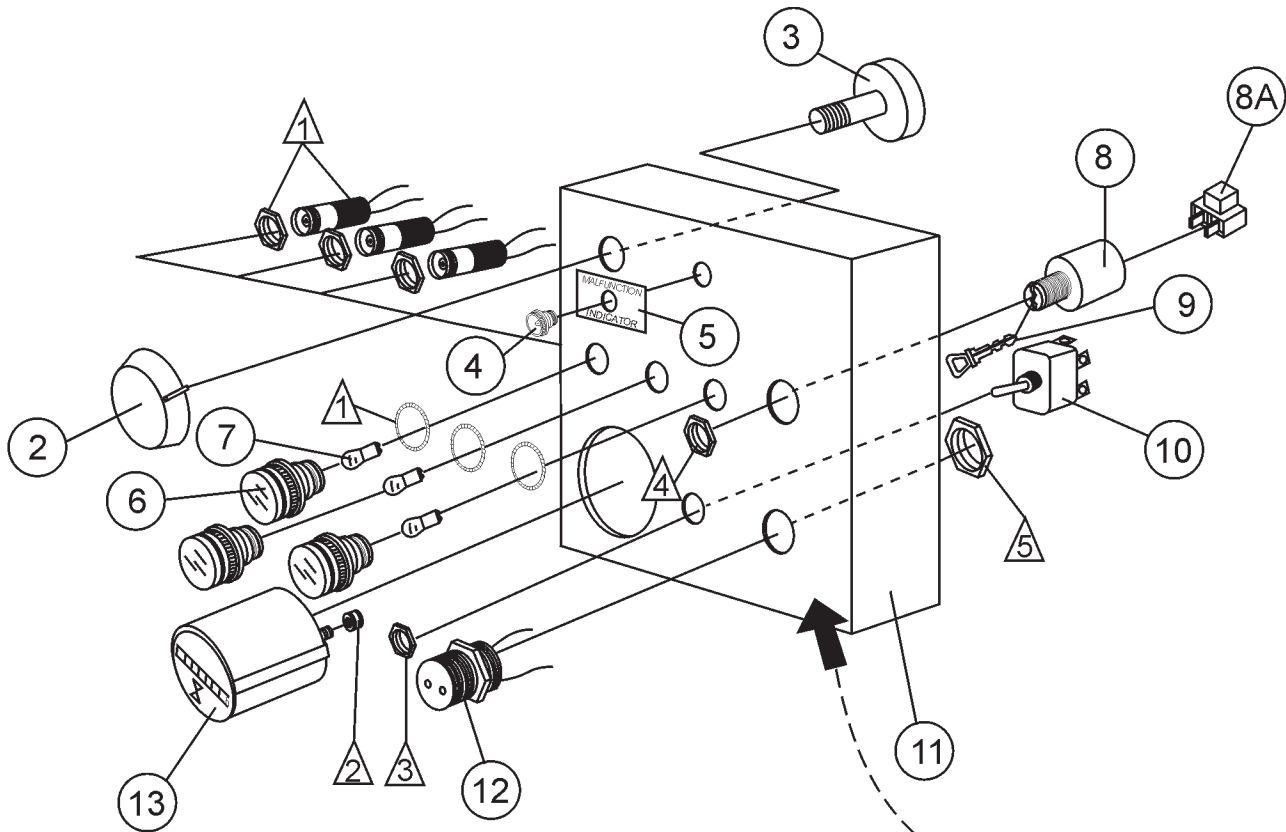

NOTES:

- ① INCLUDED WITH ITEM 6,
PILOT LAMP ASSY. P/N 513099
- ② INCLUDED WITH ITEM 13.
HOUR METER P/N 506222
- ③ INCLUDED WITH ITEM 10,
PUMPING CONTROL SWITCH P/N 40711
- ④ INCLUDED WITH ITEM 8,
IGNITION SWITCH P/N 506267
- ⑤ INCLUDED WITH ITEM 12,
REMOTE OUTLET PLUG P/N 26789

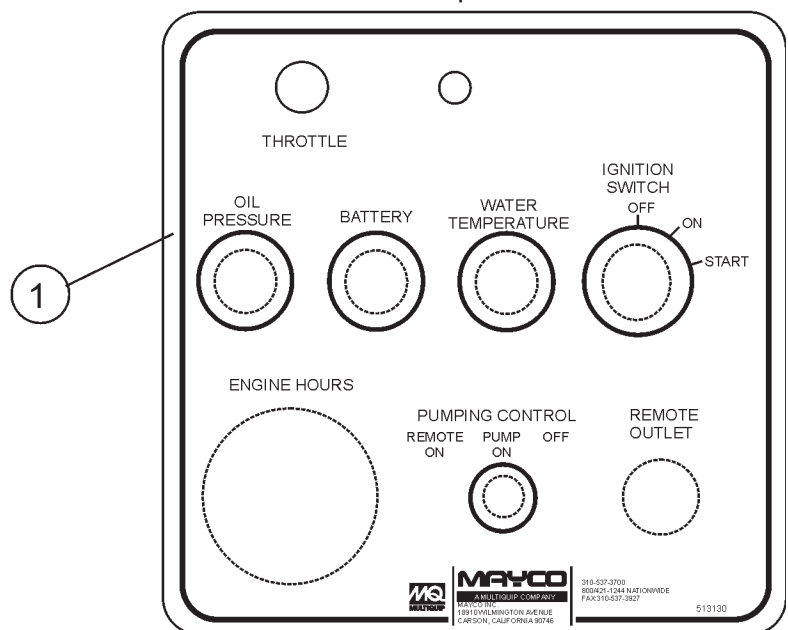

C-30HDNI (PRECISION) PUMP — CONTROL BOX ASSY.

CONTROL BOX ASSY.

<u>NO.</u>	<u>PART NO.</u>	<u>PART NAME</u>	<u>QTY.</u>	<u>REMARKS</u>
1	EM513130	FRONT PANEL OVERLAY	1	
2	P2554	KNOB, THROTTLE CONTROL	1	
3	P2204	POTENTIOMETER, THROTTLE CONTROL	1	
4	P2300	LED, MALFUNCTION INDICATOR LED	1	
5	P7655	LABEL, MALFUNCTION INDICATOR	1	
6	12305	RED PILOT LENS DIA 5/8"	3	
7	51908	12 VDC BULB	3	
8	10958	IGNITION SWITCH	1	
8A	508239	CONNECTOR, PLASTIC	1	
9	11078	IGNITION SWITCH KEY	1	
10	EM40711	SWITCH, PUMPING CONTROL	1	
11	EM513076	CONTROL BOX	1	
12	EM26789	RECEPTACLE (REMOTE)	1	
13	506222	HOURMETER	1	

C-30HDNI (PRECISION) PUMP — BATTERY ASSY.

BATTERY ASSY.

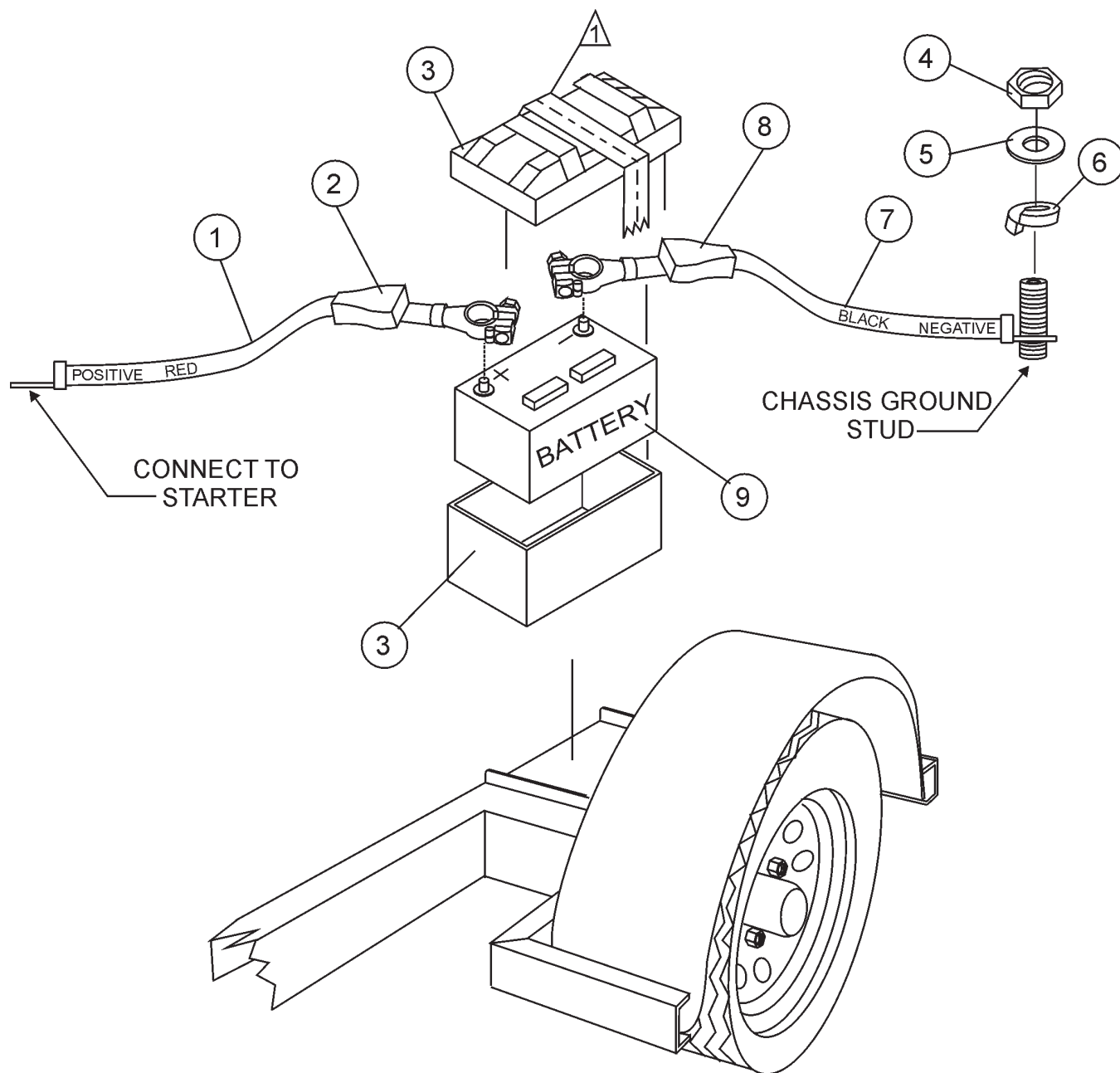

NOTES:

- ⚠ BATTERY HOLD-DOWN STRAP IS INCLUDED WITH ITEM 3, P/N 34506

C-30HDNI (PRECISION) PUMP — BATTERY ASSY.

BATTERY ASSY.

<u>NO.</u>	<u>PART NO.</u>	<u>PART NAME</u>	<u>QTY.</u>	<u>REMARKS</u>
1	EM14705	CABLE, POSITIVE BATTERY	1	
2	EM506266	COVER, POSITIVE TERMINAL	1	
3	10318	BOX, BATTERY	1	
4	EM492541	NUT, HEX 5/16- 18	1	
5	EM923023	WASHER, FLAT 5/16	1	
6	EM923343	WASHER, LOCK 5/16	1	
7	EM20720	CABLE, NEGATIVE BATTERY	1	
8	EM505624	COVER, NEGATIVE TERMINAL	1	
9	EM491344	BATTERY, 12 VOLT	1	

C-30HDNI (PRECISION) PUMP — FUEL TANK ASSY.

FUEL TANK ASSY.

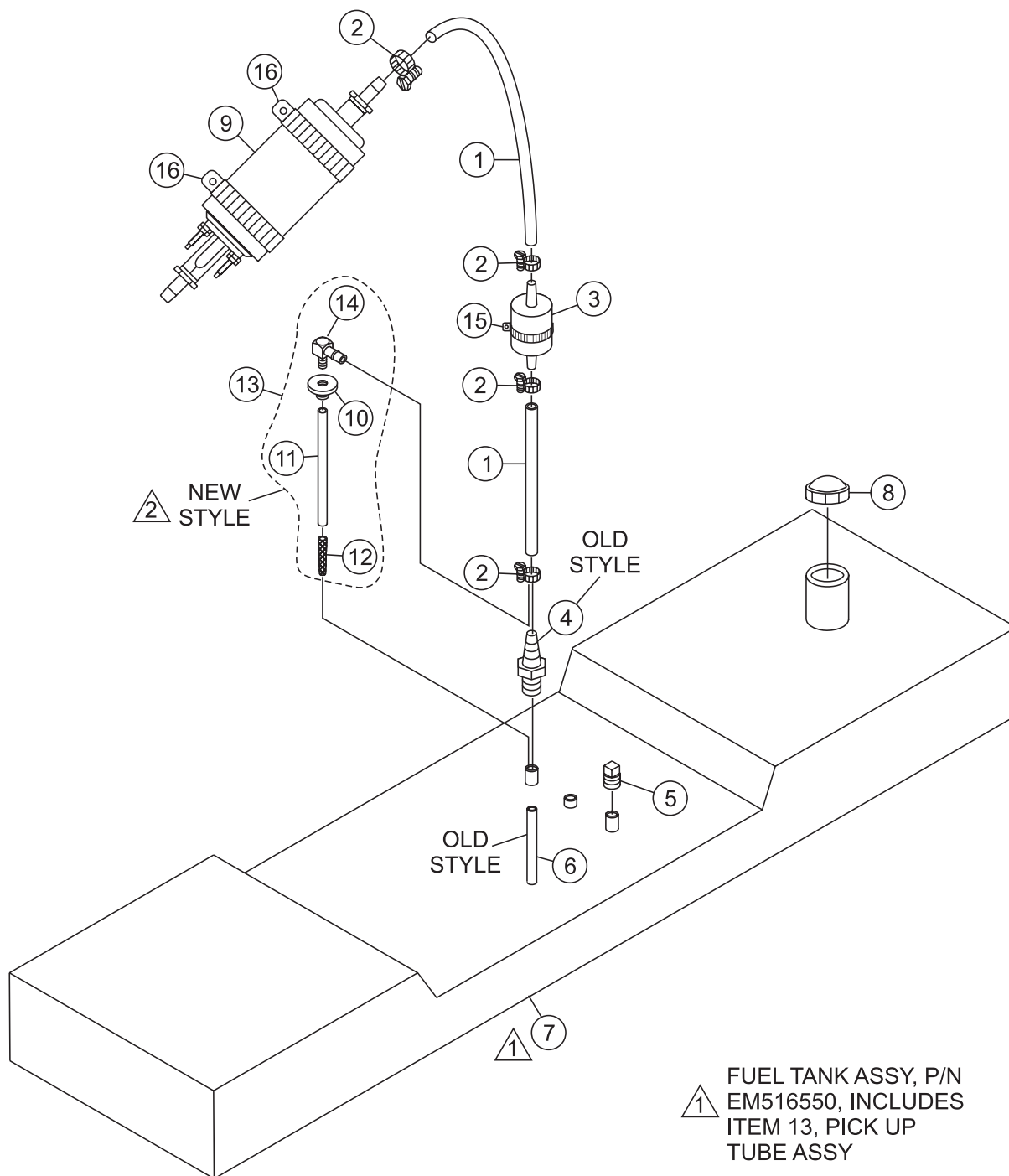

① FUEL TANK ASSY, P/N EM516550, INCLUDES ITEM 13, PICK UP TUBE ASSY

② ITEM 13, PICK UP TUBE ASSY, REPLACED ITEM 6, PIPE, AND ITEM 4, ADAPTER AFTER JULY 2005.

C-30HDNI (PRECISION) PUMP — FUEL TANK ASSY.

FUEL TANK ASSY.

<u>NO.</u>	<u>PART NO.</u>	<u>PART NAME</u>	<u>QTY.</u>	<u>REMARKS</u>
1	TBD	HOSE, FUEL 3/8 IN.	1	
2	EM506208	CLAMP, HOSE	1	
3	C282224	FILTER, FUEL	1	
4	TBD	ADAPTER.....	1	BEFORE JULY 2005
5	EM491210	PLUG, 1/4 IN.	1	
6	EM505594	PIPE, 5/16 COPPER.....	1	BEFORE JULY 2005
7	514722	FUEL TANK	1	BEFORE JULY 2005
7	EM516550	FUEL TANK ASSY	1	INCLUDES ITEM 13
			AFTER JULY 2005
8	2108	FUEL CAP	1	
9	C282-238	PUMP, FUEL	1	
10#	19633	BUSHING	1	AFTER JULY 2005
11#	60058	HOSE, 4-1/2"	1	AFTER JULY 2005
12#	12009	SCREEN	1	AFTER JULY 2005
13	EM516533	PICK UP TUBE ASSY	1	INCLUDES ITEMS W/#
			AFTER JULY 2005
14#	12008	FITTING	1	AFTER JULY 2005
15	C282314	CLAMP, FUEL FILTER, #34 2-1/8" ID	1	
16	C282315	CLAMP, FUEL PUMP, #26 1-5/8" ID	2	

C-30HDNI (PRECISION) PUMP — HOPPER ASSY.

HOPPER ASSY.

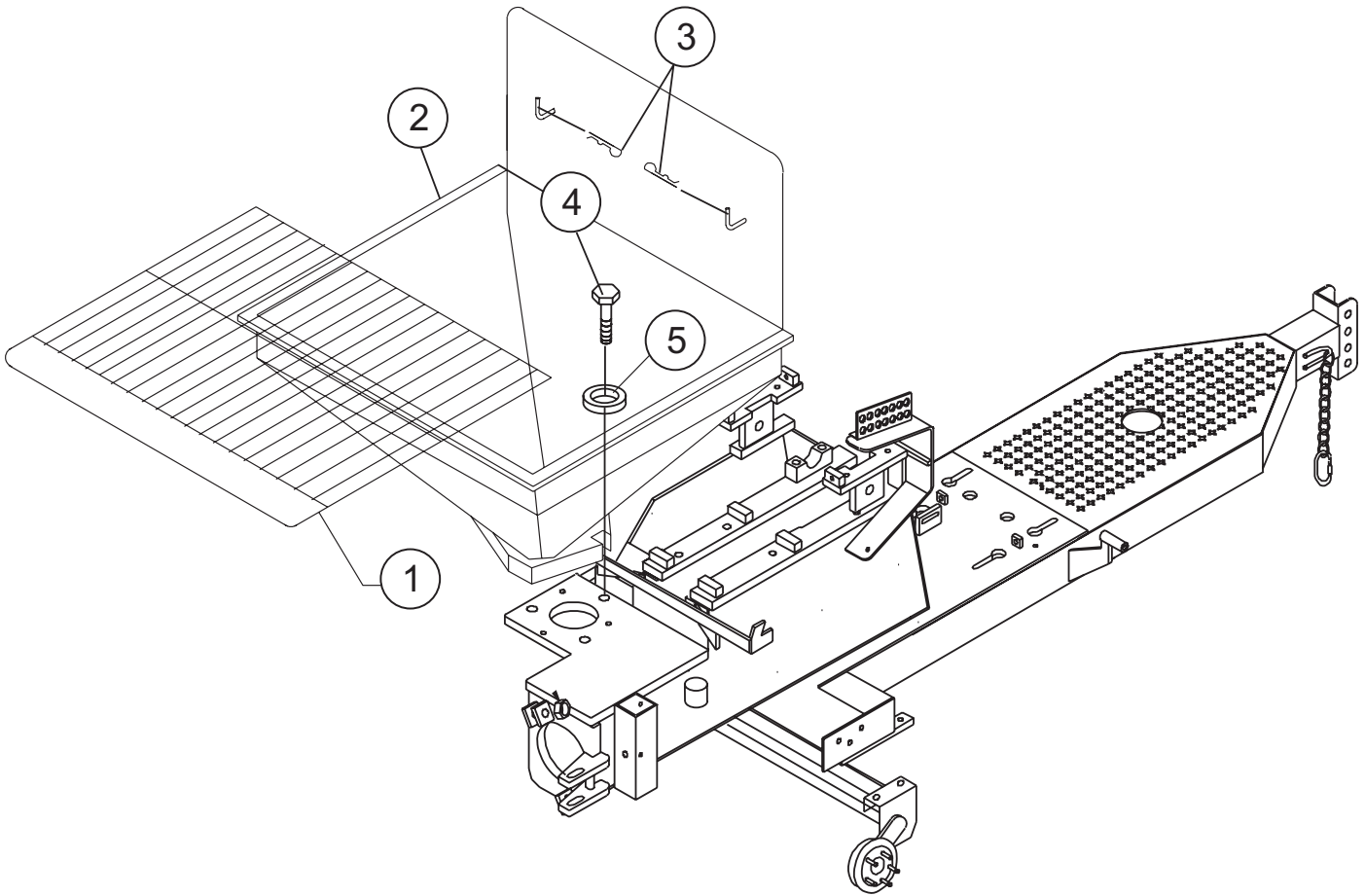

C-30HDNI (PRECISION) PUMP — HOPPER ASSY.

HOPPER ASSY.

<u>NO.</u>	<u>PART NO.</u>	<u>PART NAME</u>	<u>QTY.</u>	<u>REMARKS</u>
1	EM14159	HOPPER SCREEN	1	
2	EM14141	HOPPER	1	
3	EM925191	PIN, HAIR	2	
4	EM104	BOLT, 5/8"-11X2" HEX HEAD	3	
5	EM507599	WASHER 5/8" FLAT	3	

C-30HDNI (PRECISION) PUMP — HOOD ASSY.

HOOD ASSY.

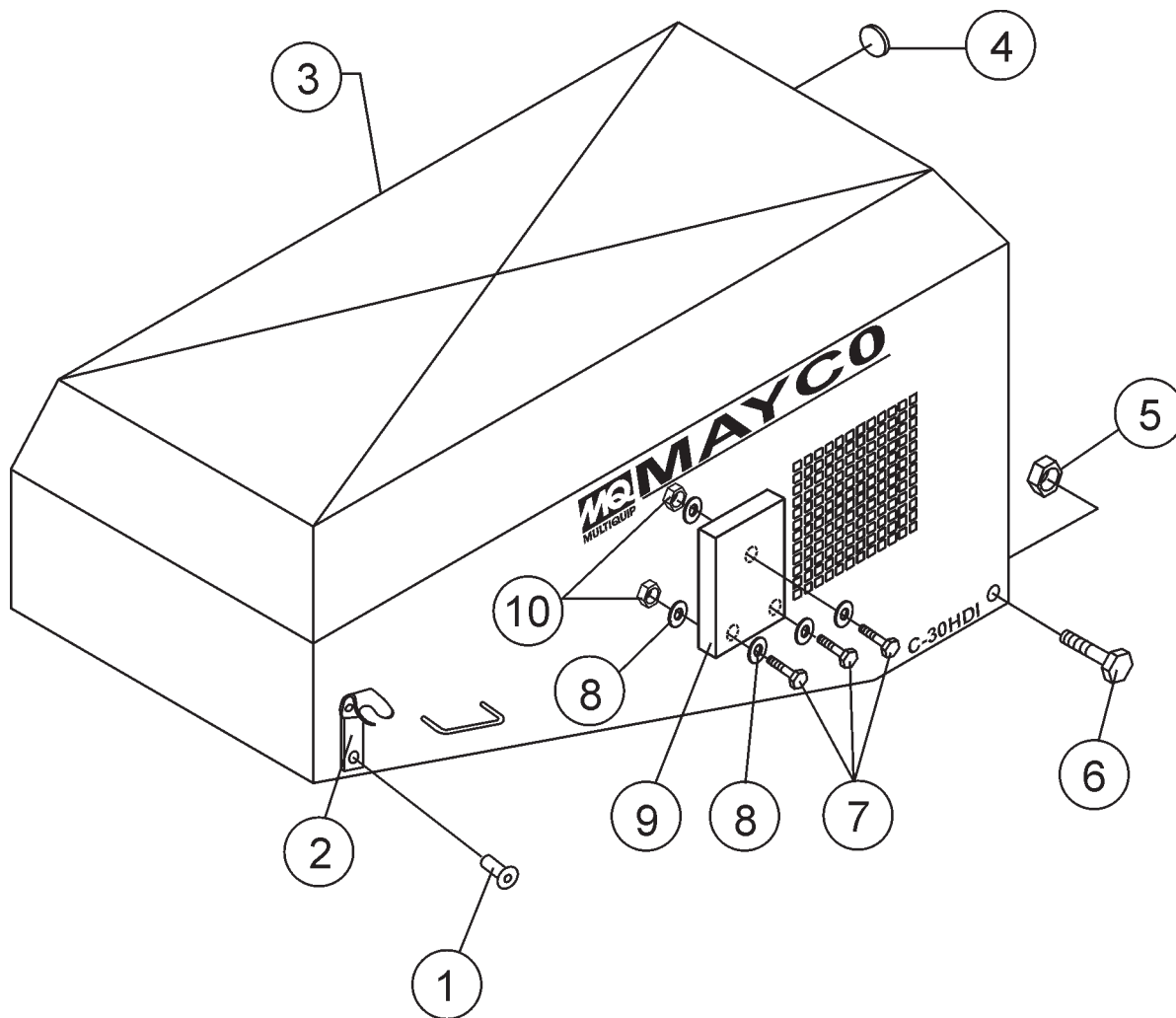

C-30HDNI (PRECISION) PUMP — HOOD ASSY.

HOOD ASSY.

<u>NO.</u>	<u>PART NO.</u>	<u>PART NAME</u>	<u>QTY.</u>	<u>REMARKS</u>
1	503723	RIVET	4	
2	491010	LATCH KIT	2	
3	EM513120	HOOD ASSY.	1	
4	490937	BUMPER, RUBBER	2	
5	EM406	NUT 1/2"-13 HEAVY HEX	2	
6	EM124	BOLT 1/2" DIA-NC X4" G5	2	
7	EM963003	SCREW, HHC 1/4-20 X 3/4	3	
8	EM923057	WASHER	3	
9	29057	MANUAL HOLDER	1	
10	EM969079	NUT LOC NYLON 1/4	3	
11	RAL1003S	PAINT, SPRAY CAN 12 OZ. (YELLOW)	AR	
12	RAL1003G	PAINT, GALLON (YELLOW)	AR	

C-30HDNI (PRECISION) PUMP — LUBRICATION PANEL ASSY.

LUBRICATION PANEL ASSY.

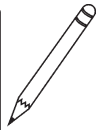
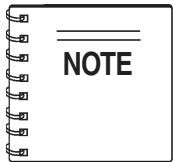
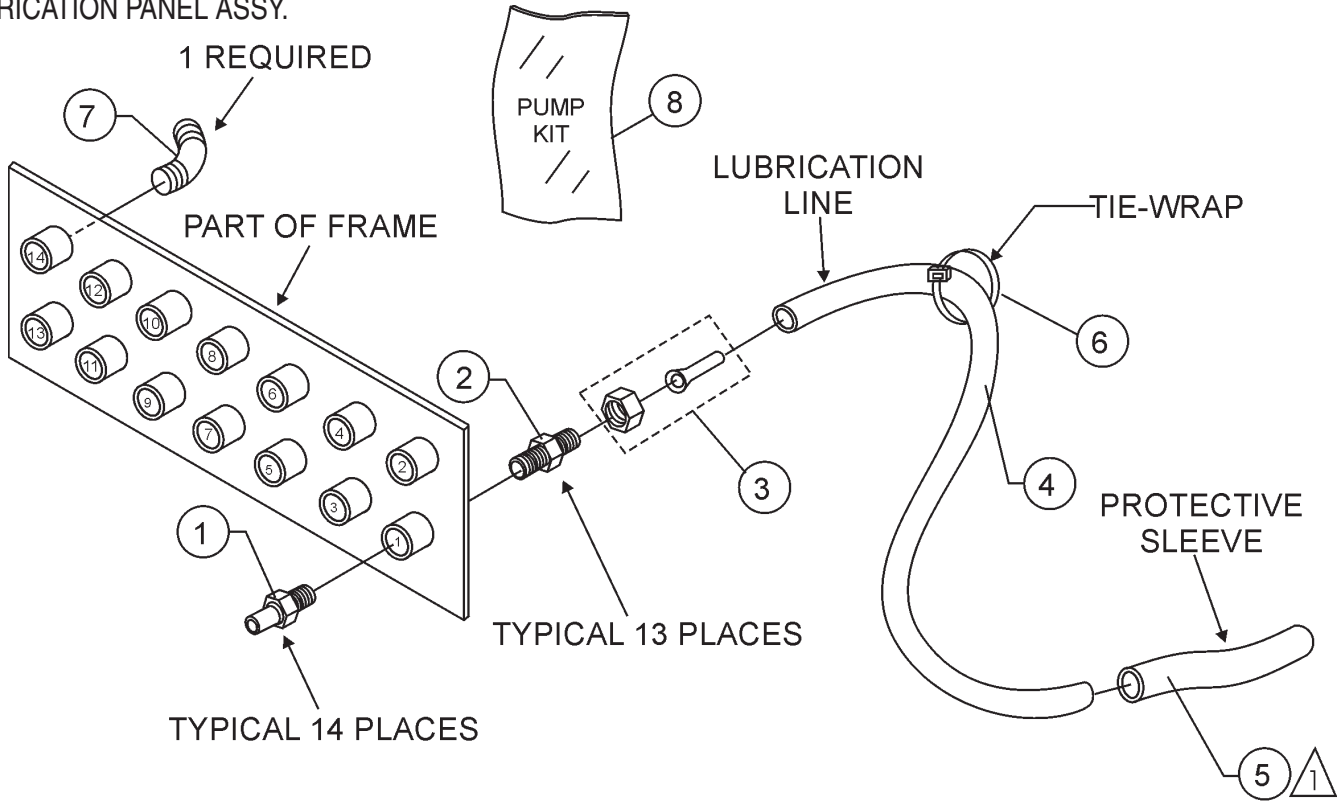

Grease **daily**, two to three shots of #2 multi-purpose automotive grease. Over-greasing any bearing will not damage the machine.

NOTES:

⚠ PLACE PROTECTIVE SLEEVE OVER LUBRICATION LINES 1 THROUGH 6.

<u>POSITION</u>	<u>LOCATION</u>	<u>LENGTH OF LINES</u>
1	COMPENSATOR ROD	28"
2	COMPENSATOR ROD	31"
3	COMPENSATOR ROD	28"
4	LOWER ROCKER ARM COMPENSATOR ROD	34"
5	LOWER CONNECTING ROD- DRIVE SIDE	10"
6	LOWER ROCKER ARM - DRIVE SIDE	15"
7	UPPER ROCKER ARM - COMPENSATOR SIDE	28"
8	UPPER ROCKER ARM - DRIVE SIDE	26"
9	COUNTER SHAFT BEARING - SPROCKET SIDE	20"
10	COUNTER SHAFT - PULLEY SIDE	20"
11	UPPER CONNECTING ROD - DRIVE SIDE	40"
12	CRANKSHAFT BEARING BLOCK	42"
13	CAM BEARING	42"
14	CRANKSHAFT BEARING FLANGE	20"
	TOTAL LENGTH OF LINES REQUIRED	384"

C-30HDNI (PRECISION) PUMP — LUBRICATION PANEL ASSY.

LUBRICATION PANEL ASSY.

<u>NO.</u>	<u>PART NO.</u>	<u>PART NAME</u>	<u>QTY.</u>	<u>REMARKS</u>
1*	EM916001	FITTING, GREASE 1/8" NPT	14	
2*	EM505489	STRAIGHT FITTING 1/8" NPT	13	
3*	505534	COUPLING W/NUT 1/8" NPT	14	
4*	EM505516	PLASTIC HOSE LINE 1/4" DIA. AR		1FT=1PC
5*	EM490531	PROTECTIVE SLEEVE 3/8" (HOSE)	AR	1FT=1PC
6*	EM491028	TIE-WRAP 2.5 x 95 MM	AR	
7*	EM505490	ADAPTER, 90 DEGREE ELBOW	1	
8	EM512659	KIT, LUBRICATION	1	INCLUDES ITEMS W/*

C-30HDNI (PRECISION) PUMP — REMOTE CONTROL CABLE ASSY.

REMOTE CONTROL CABLE ASSY.

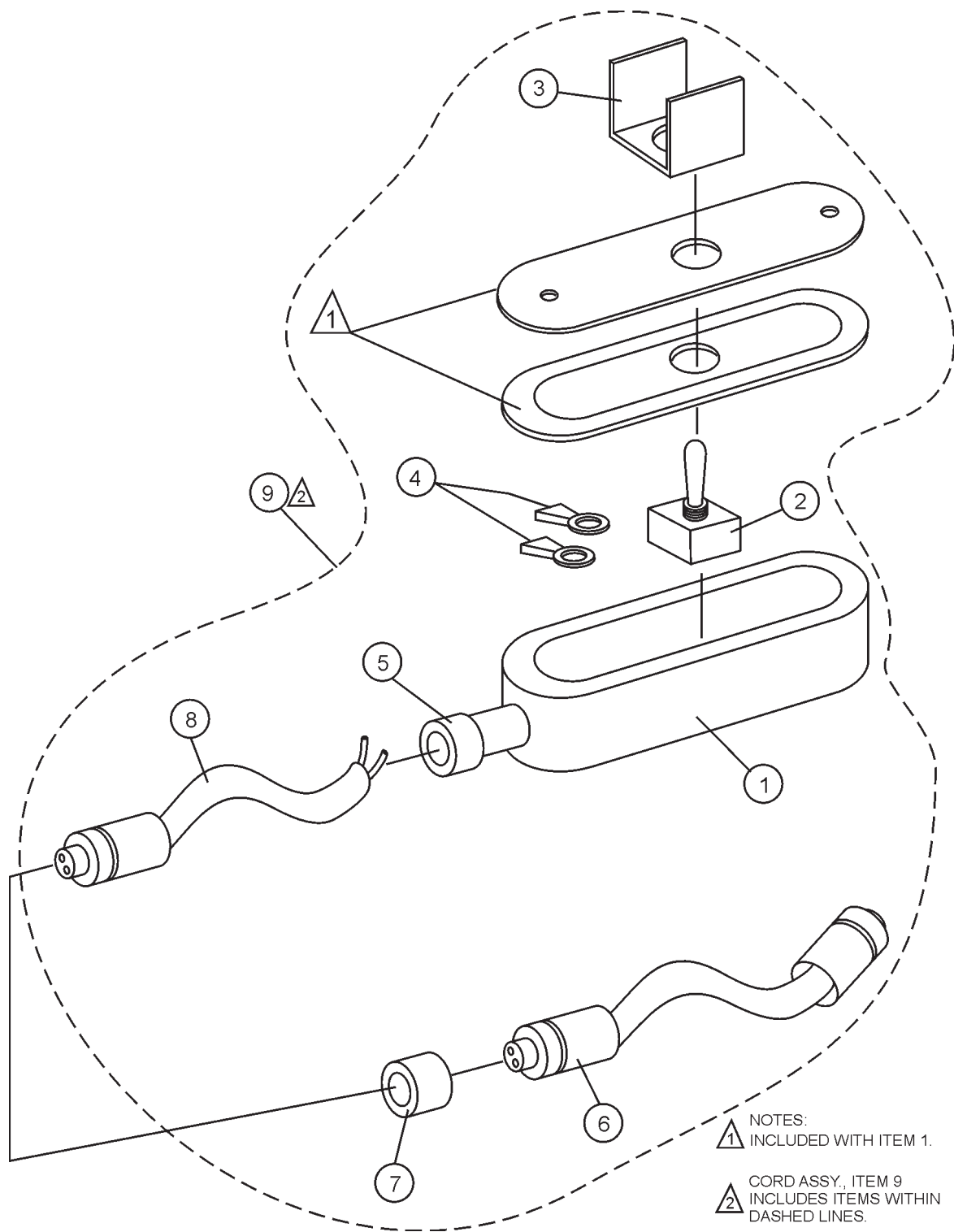

C-30HDNI (PRECISION) PUMP — REMOTE CONTROL CABLE ASSY.

REMOTE CONTROL CABLE ASSY.

<u>NO.</u>	<u>PART NO.</u>	<u>PART NAME</u>	<u>QTY.</u>	<u>REMARKS</u>
1*	EM16753	JUNCTION BOX	1	
2*	EM16754	SWITCH, MICRO	1	
3*	EM16756	GUARD SWITCH - ALUMINUM	1	
4*	EM491897	CONNECTOR, 3/16 RING	2	
5*	EM26791	GRIP CORD SEAL	1	
6*	EM26790	CORD 25' MX P/E	1	
7*	EM26793	ADAPTER CORD GRIP 1/2"	1	
8*	EM26792	ADAPTER CORD 100 FT.	1	
9	EM26788	COMPLETE CORD ASSY 25 FT	1	INCLUDES ITEMS W/*

C-30HDNI (PRECISION) PUMP — EFI GASOLINE FUEL SYSTEM ASSY.

EFI GASOLINE FUEL SYSTEM ASSY.

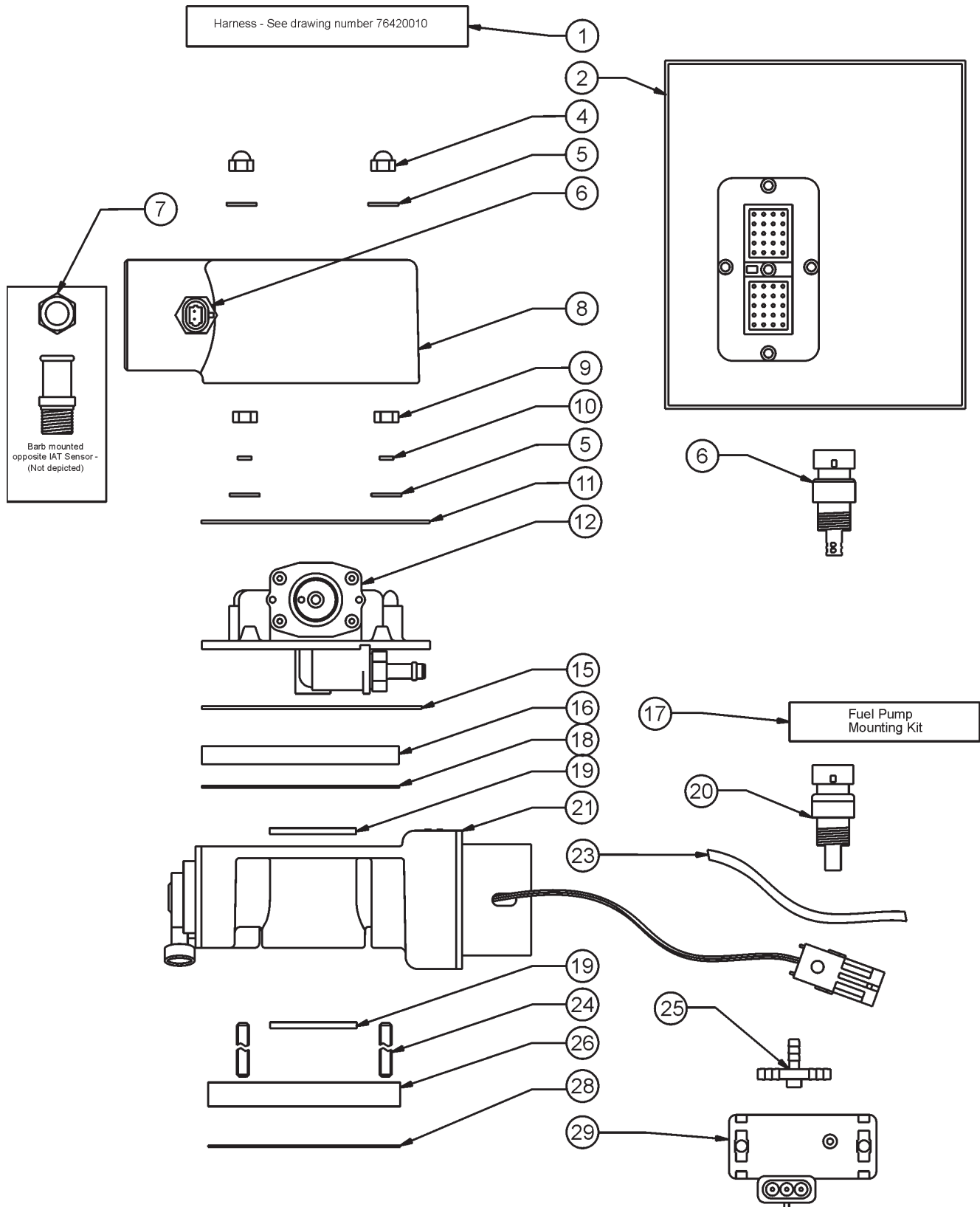

C-30HDNI (PRECISION) PUMP — EFI GASOLINE FUEL SYSTEM ASSY.

EFI GASOLINE FUEL SYSTEM ASSY.

<u>NO.</u>	<u>PART NO.</u>	<u>PART NAME</u>	<u>QTY.</u>	<u>REMARKS</u>
1	P7642010	A15 GAS ONLY WIRING HARNESS	1	
2	P9397	EFI CONTROLLER SOFTWARE	1	USER SPECIFIC
			CONTACT PRECISION GOVERNORS
4	P3395	1/4 - 20 ACORN NUT (NICKEL)	2	
5	P3241	1/4" WASHER	4	
6	P2559	AIR TEMP SENSOR	1	
7	P3363	3/8 NPT - 5/8 BARB	1	
8	P7625	AIR HORN	1	
9	P3004	1/4-20 UNC NUT	2	
10	P3005	1/4" LOCK WASHER	2	
11	P7619	AIR HORN GASKET	1	
12	P5184	DELPHI FUEL RING	1	
15	P7618	DELPHI FUEL RING GASKET	1	
16	P7623	TOP PLATE FUEL RING ADAPTER	1	
17	P2571	FUEL PUMP MOUNTING KIT	1	
19	P2562	THROTTLE BODY O-RING	1	
20	P3206	ENGINE COOLANT TPP. SENSOR	1	
21	P7600	THROTTLE BODY ASSY	1	
23	P3389	3/16" VACUUM HOSE 24" LONG	1	
24	P3348	1/4-20 UNC X 6" LONG THREADED ROD	2	
25	P3366	3/16" T-FITTING FOR VACUUM HOSE	1	
26	P7635	ENGINE MANIFOLD ADAPTER PLATE	1	
28	P7668	INTAKE MANIFOLD GASKET	1	
29	P2560	MAP SENSOR	1	
30	P2561	OXYGEN SENSOR	1	
31	4RD93141008	FUEL RELAY	1	NOT ILLUSTRATED

A15 NISSAN ENGINE — CYLINDER BLOCK & OIL PAN ASSY.

CYLINDER BLOCK & OIL PAN ASSY.

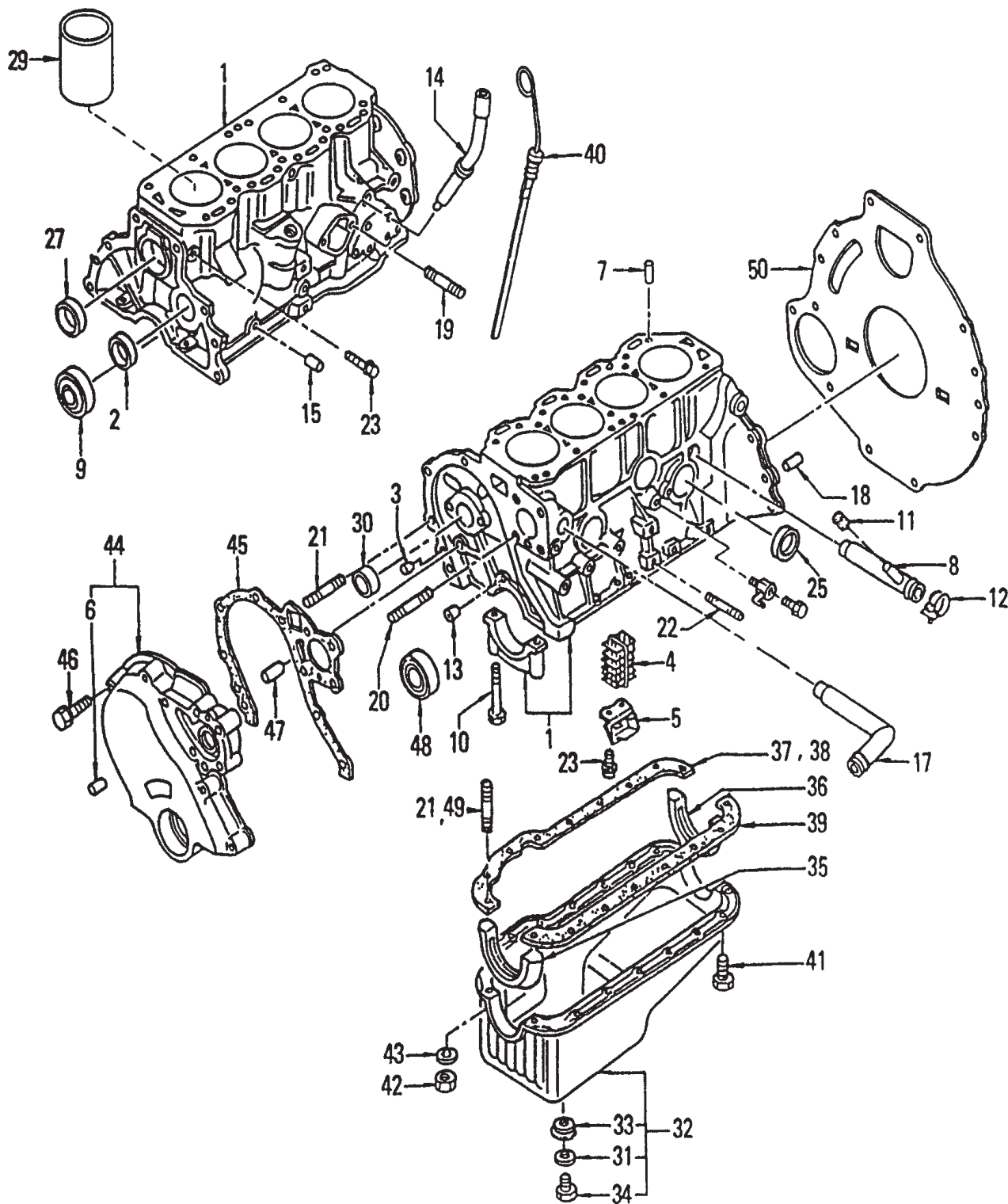

A15 NISSAN ENGINE — CYLINDER BLOCK & OIL PAN ASSY.

CYLINDER BLOCK & OIL PAN ASSY.

NO.	PART NO.	PART NAME	QTY.	REMARKS
1	11010K4970	BLOCK ASSY.- CYL	1	
2	1101932200	PLUG- WELCH (44 425)	1	
3	11024K0100	PLUG- TAPER (12.7)	2	
4	11037H1000	NET- STEEL CRANK CASE	1	
5	11038H9700	PLATE- BAFFLE	1	
6#	1104673402	DOWEL- 5	2	
7	1105373400	DOWEL BLOCK TO HEAD	2	
8	11830G3600	PIPE ASSY.- CONN	1	
9	12279H2301	SEAL- OIL CRANK RR	1	
10	1229301M00	BOLT MAIN BRG. CAP	10	
13	1512718000	ORIFICE- OIL GAL	1	
14	15146H5002	GUIDE- OIL GAUGE	1	
15	0164700011	PLUG- TAPER (6)	7	
17	21045K4920	PIPE- SUCT, WATER	1	
18	30412H1001	DOWEL- 9.5	2	
19	0821383510	STUD	2	
20	0821385510	STUD	3	
21	0821661610	STUD	2	
22	0822382010	STUD	4	
23	0831061214	SCREW	2	
25	009331355A	PLUG- WELCH	3	
27	0093315010	PLUG- WELCH	1	
29	11012H7200	LINER- CYL,400	AR	
29	11013H7200	LINER- CYL,450	AR	
30	13002H1020	BUSH SET- CAM (STD.)	1	
30	13003H1020	BUSH SET- CAM (US=0.25)	1	
30	13004H1020	BUSH SET- CAM (US=0.50)	1	
30	13005H1020	BUSH SET- CAM (US=0.75)	1	
31*	1102661000	WASHER	1	
32	11110K4920	OIL PAN	1	INCLUDES ITEMS W/*
33*	1111961000	SEAT- DRAIN PLUG	1	
34*	1112869200	PLUG- DRAIN	1	
35	1113018002	SEAL- OIL PAN FR	1	
36	1113118002	SEAL- OIL PAN FR	1	
37	11132H5025	GASKET- OIL PAN RH	1	
39	11132H5025	GASKET- OIL PAN LH	1	
40	11140H7200	DIPSTICK	1	
41	081106161B	BOLT	12	
42	0891110610	NUT	4	
43	089151361A	WASHER	4	
44	13035H1000	COVER TIMING CHAIN	1	INCLUDES ITEMS W/#
45	13044H1001	GASKET COVER TIMING	1	
46	081208161B	BOLT	1	
47	1104673402	DOWEL	1	
48	13510H1010	OIL SEAL CRANK FR	1	
49	0821666100	STUD- COARSE THD.	2	
50	30411H5001	PLATE- ENG. RR	1	

A15 NISSAN ENGINE — CYLINDER HEAD & VALVE COVER ASSY.

CYLINDER HEAD & VALVE COVER ASSY.

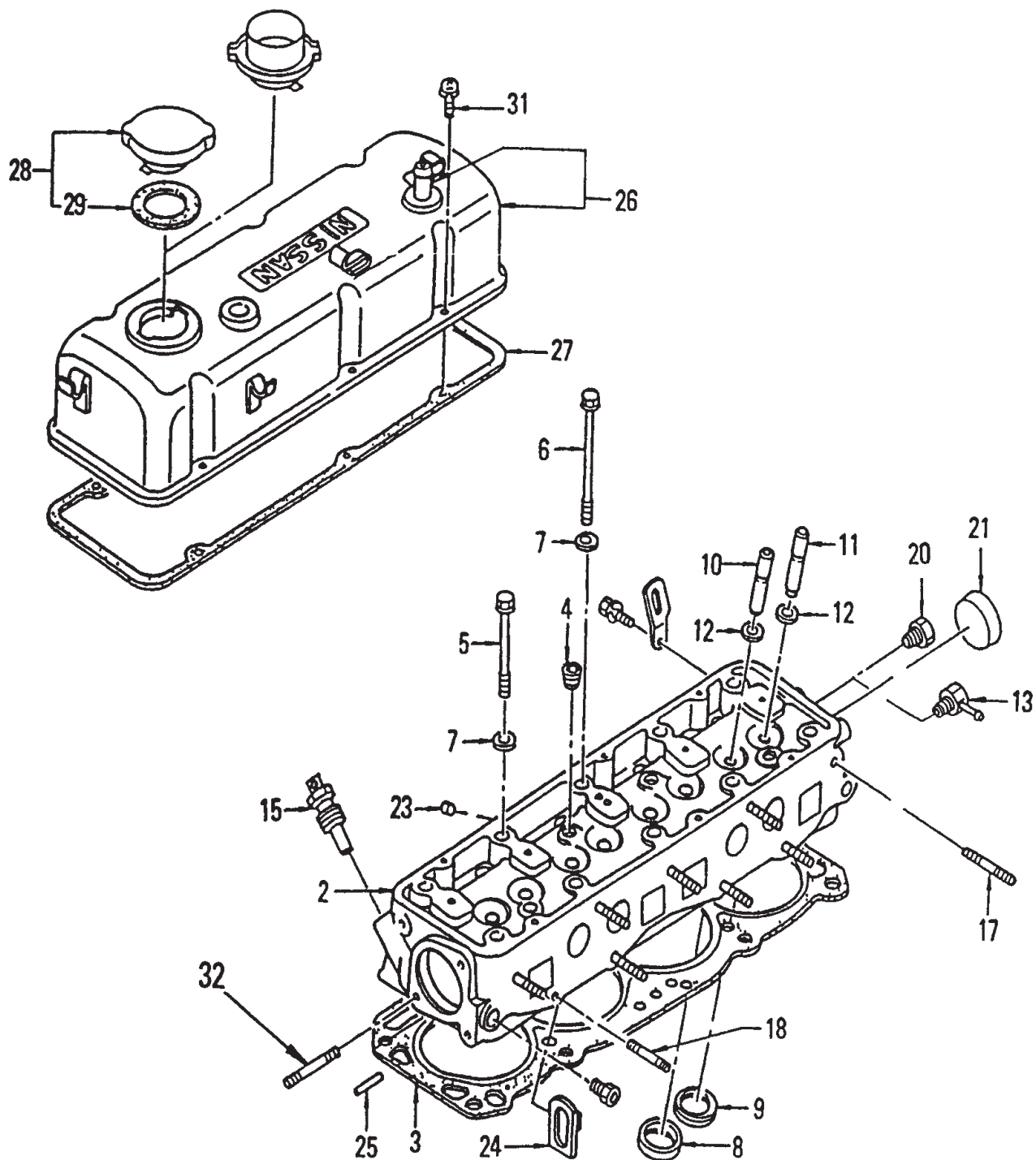

A15 NISSAN ENGINE — CYLINDER HEAD & VALVE COVER ASSY.

CYLINDER HEAD & VALVE COVER ASSY.

<u>NO.</u>	<u>PART NO.</u>	<u>PART NAME</u>	<u>QTY.</u>	<u>REMARKS</u>
2	11041K4970	HEAD ASSEMBLY- CYLINDER	1	
3	11044H9822	GASKET- CYLINDER HEAD	1	
4	1105173403	PLUG- BLIND CYLINDER HEAD	4	
5	11056H1000	BOLT- CYLINDER HEAD	9	
6	11057H5000	BOLT- CYLINDER HEAD	1	
7	1105821002	WASHER- BOLT HEAD	10	
8	11098H7512	INSERT- VALVE, INT.	4	
9	11099H8910	INSERT- VALVE, EXH.	4	
10	13212H8500	GUIDE- VALVE, INT.	4	
11	13213H2312	GUIDE- VALVE, EXH.	4	
12	1321473400	RING- SNAP VALVE GUIDE	8	
15	2508089912	TEMP. ENG. UNIT	1	
17	0822382810	STUD	7	
18	0822383510	STUD	2	
20	0093130610	PLUG- TAPER	1	
21	009331401A	PLUG- WELCH	1	
23	0093320670	TEMP. ENG. UNIT	1	
24	10005M1000	SLINGER- ENG. FR	2	
25	1002332200	DOWEL	1	
26	13264G1361	VALVE COVER	1	
27	13270H1000	PACKING- VALVE COVER	1	
28*	1525585030	CAP ASSEMBLY- OIL FILL	1	INCLUDES ITEMS W/*
29	15270B3400	PACKING- OIL FILLER CAP	1	
31	0831061614	SCREW	6	
32	14065W1300	STUD	2	
	1010105H25	GASKET SET, OVERHAUL	1	

A15 NISSAN ENGINE — CRANKCASE VENTILATION ASSY.

CRANKCASE VENTILATION ASSY.

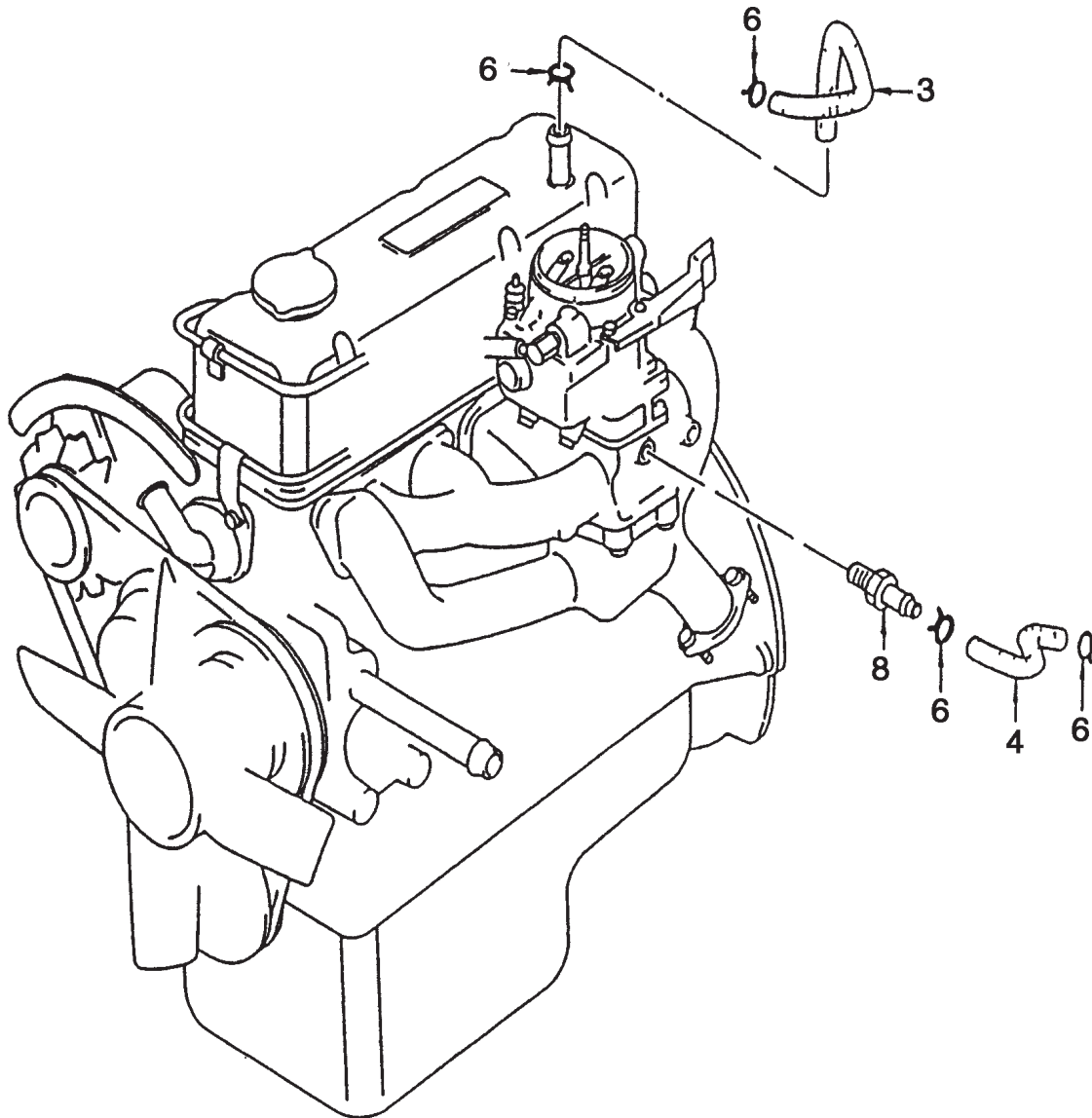

A15 NISSAN ENGINE — CRANKCASE VENTILATION ASSY.

CRANKCASE VENTILATION ASSY.

<u>NO.</u>	<u>PART NO.</u>	<u>PART NAME</u>	<u>QTY.</u>	<u>REMARKS</u>
3	11823K4901	HOSE BLOWBY	1	
4	11828G2561	HOSE- PIPE CONNECTION	1	
6	1643910B00	CLAMP- HOSE	2	
8	11810A3501	PCV VALVE	1	

A15 NISSAN ENGINE — PISTON, CRANKSHAFT AND FLYWHEEL ASSY.

PISTON, CRANKSHAFT AND FLYWHEEL ASSY.

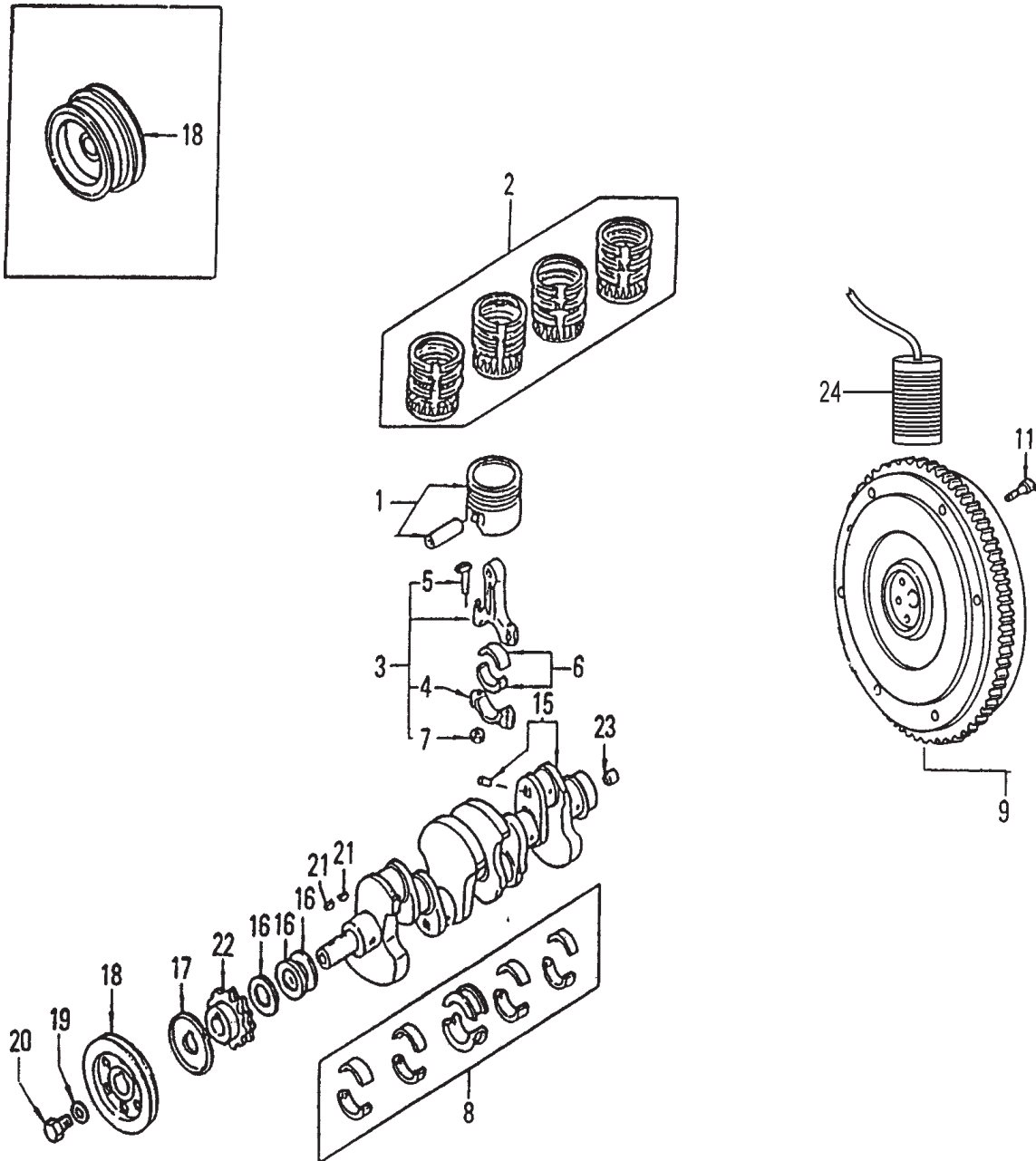

A15 NISSAN ENGINE — PISTON, CRANKSHAFT AND FLYWHEEL ASSY.

PISTON, CRANKSHAFT AND FLYWHEEL ASSY.

<u>NO.</u>	<u>PART NO.</u>	<u>PART NAME</u>	<u>QTY.</u>	<u>REMARKS</u>
1	12010G3462	PISTON SET- W PIN, STANDARD	4	
1	12010G3465	PISTON SET- W PIN, OS=0.50	4	
1	12010G3467	PISTON SET- W PIN, OS=1.00	4	
2	12033H9820	RING SET- PISTON, STANDARD	1	
2	12035H9820	RING SET- PISTON, OS=0.50	1	
2	12037H9820	RING SET- PISTON, OS=1.00	1	
3	12100H7200	ROD ASSEMBLY- CONN.	4	INCLUDES ITEMS W/*
4*	12106H1000	CAP- CONN. ROD	4	
5*	12109H1012	BOLT- CONN. ROD	8	
6	1211120910	BUSH- CONN. ROD, STANDARD	8	
6	1211120901	BUSH- CONN. ROD, US=0.08	8	
6	1211120902	BUSH- CONN. ROD, US=0.12	8	
6	1211120903	BUSH- CONN. ROD, US=0.25	8	
6	1211120904	BUSH- CONN. ROD, US=0.50	8	
6	1211120905	BUSH- CONN. ROD, US=0.75	8	
6	1211120906	BUSH- CONN. ROD, US=1.00	8	
7*	12112H1000	NUT- HEX CONN. ROD	8	
8	12207M7201	BEARING SET, STANDARD	1	
8	12208M7200	BEARING SET, OS= 0.20	1	
8	12209M7201	BEARING SET, OS=0.25	1	
8	12210M7201	BEARING SET, OS= 0.50	1	
8	12211M7201	BEARING SET, OS= 0.75	1	
8	12212H1000	BEARING SET, OS=1.00	1	
9	12310K4970	FLYWHEEL ASSEMBLY	1	
11	12315H6200	FLYWHEEL BOLT	6	
15	12200G3400	CRANKSHAFT ASSEMBLY	1	
16	1230130000	WASHER	AR	
17	1230218000	OIL- THROWER, CRANK	1	
18	12303G2512	CRANK PULLEY	1	
19	12308H1000	WASH PULLEY BOLT	1	
20	1230978200	BOLT- CRANK PULLEY	1	
21	1231630000	KEY- WDF, 5 X 16	2	
22	13021H8900	SPROCKET- CRANK	1	
23	3220218010	BUSH- PILOT	1	
24	P9410	SENSOR, EFI PROXIMITY	1	

A15 NISSAN ENGINE — CAMSHAFT AND VALVE MECHANISM ASSY.

CAMSHAFT AND VALVE MECHANISM ASSY.

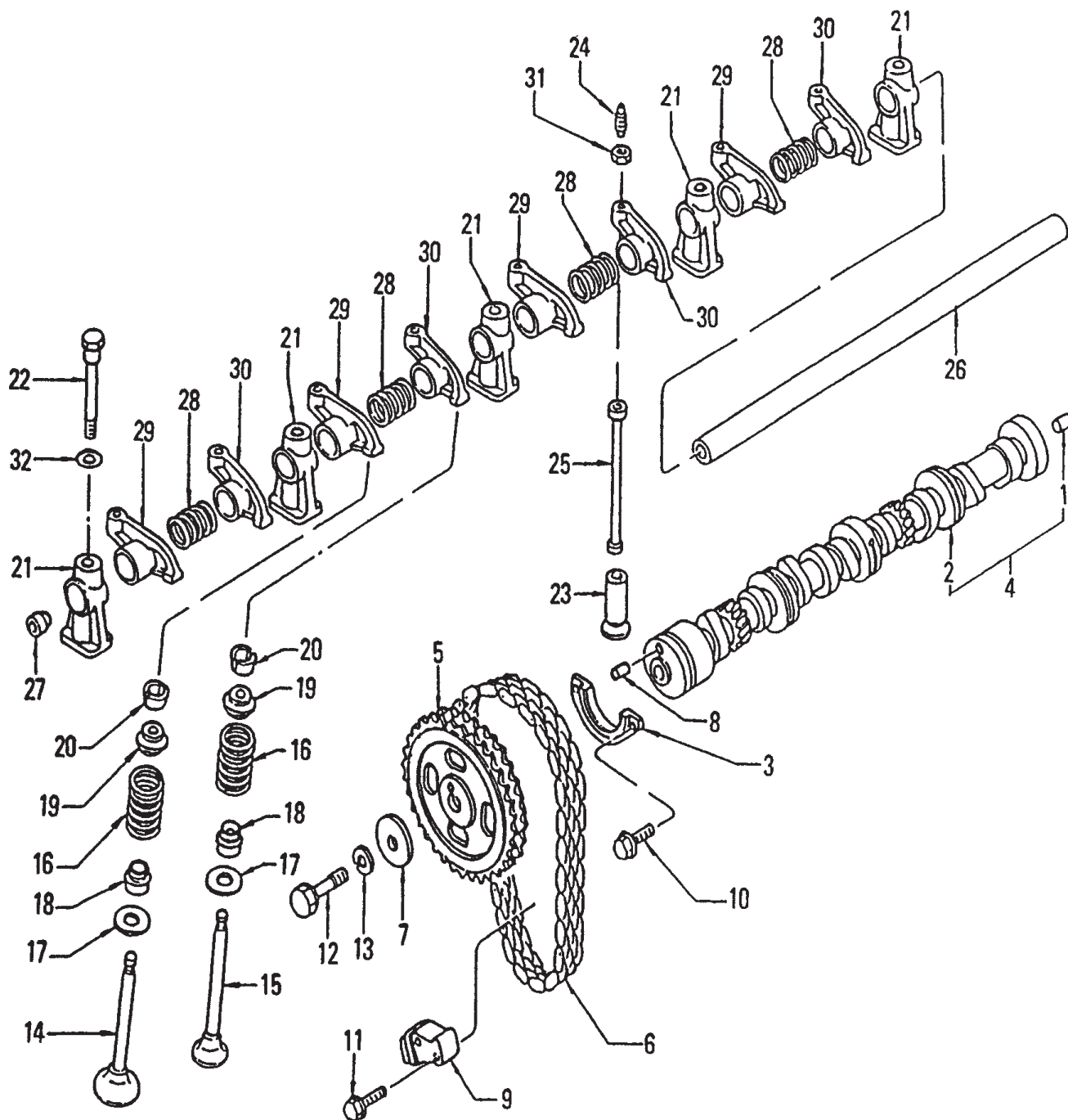

A15 NISSAN ENGINE — CAMSHAFT AND VALVE MECHANISM ASSY.

CAMSHAFT AND VALVE MECHANISM ASSY.

<u>NO.</u>	<u>PART NO.</u>	<u>PART NAME</u>	<u>QTY.</u>	<u>REMARKS</u>
1*	1102378200	PLUG- TAPER	1	
2*	13001H9800	CAMSHAFT	1	
3	1301018001	PLATE- LOCAT. CAM	1	
4	13020H9800	CAMSHAFT ASSEMBLY	1	INCLUDES ITEMS W/*
5	13024H8660	SPROCKET- CAM	1	
6	1302818001	CHAIN- CAMSHAFT	1	
7	1303018000	WASHER PLAIN	1	
8	1303218000	DOWEL- CAM	1	
9	1307018001	TENSIONOR ASSEMBLY	1	
10	081106161B	BOLT	2	
11	0812063562	BOLT	2	
12	081310401A	BOLT	1	
13	089152402A	WASHER	1	
14	13201H6200	VALVE- INTAKE	4	
15	13202H6200	VALVE- EXHAUST	4	
16	13203H1000	SPRING- VALVE	8	
17	1320518000	SEAT- VALVE SPRING	8	
18	13207H7210	SEAL- VALVE OIL	8	
19	13209H2302	RETAINER- SPRING	8	
20	13210U0100	COLLECT- VALVE	16	
21	1322218001	BRACKET- ROCKER SHAFT	5	
22	1322418000	BOLT- HEX ROCKER SHAFT	5	
23	13231H1001	VALVE LIFTER	8	
24	1323418000	SCREW- ADJUST	8	
25	13238H6201	PUSH ROD	8	
26	1325218000	SHAFT ASSEMBLY ROCKER	1	
27	1325458000	PLUG	2	
28	1325618000	SPRING- INSIDE ROCKER	4	
29	1325718003	ROCKER VALVE 1	4	
30	1325818003	ROCKER VALVE 2	4	
31	13288H5000	NUT- ADJUST SCREW	8	
32	0891543800	WASHER, FLAT M8	5	

A15 NISSAN ENGINE — MANIFOLD ASSY.

MANIFOLD ASSY.

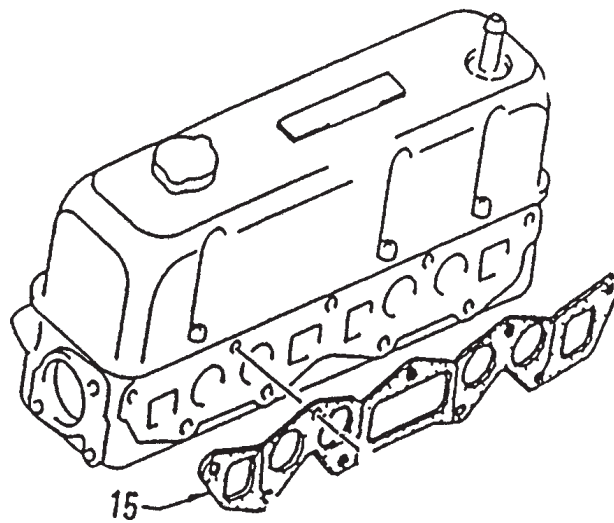
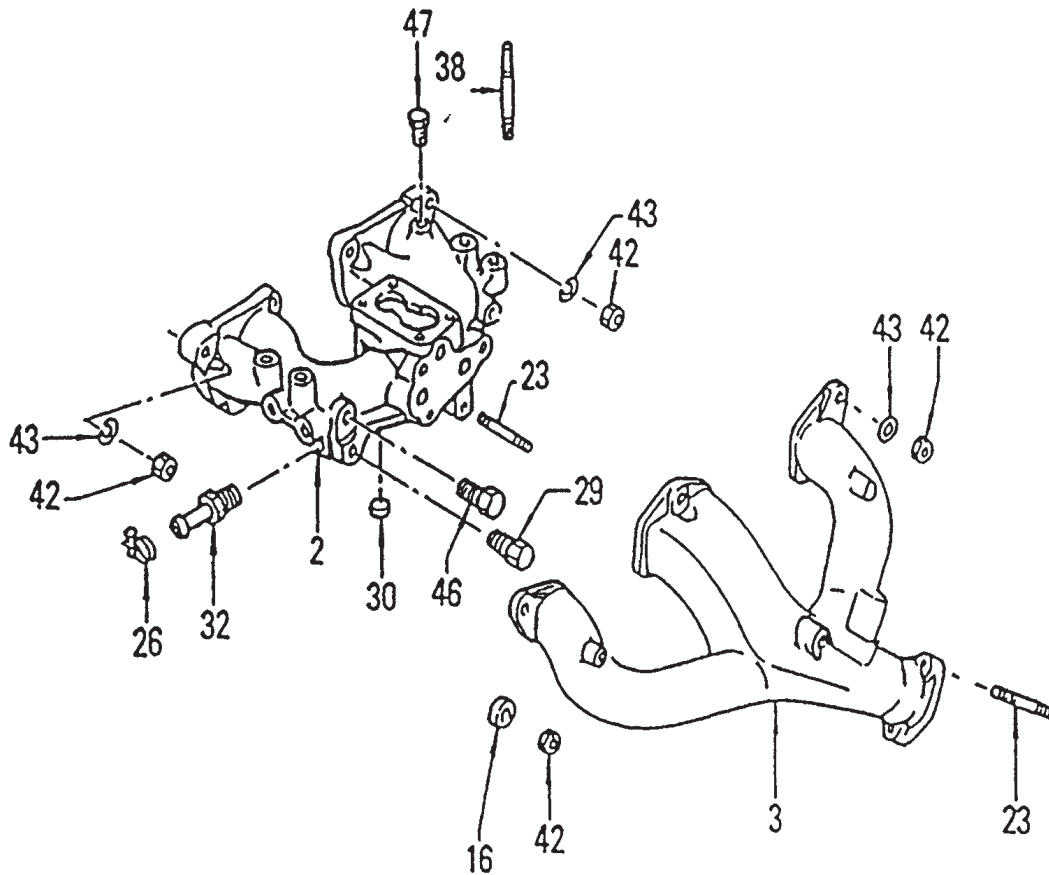

A15 NISSAN ENGINE — MANIFOLD ASSY.

MANIFOLD ASSY.

<u>NO.</u>	<u>PART NO.</u>	<u>PART NAME</u>	<u>QTY.</u>	<u>REMARKS</u>
2	14001K4970	INTAKE MANIFOLD	1	
3	14004G5200	EXHAUST MANIFOLD	1	
15	1403505H01	GASKET- MANIFOLD	1	
16	14037N3600	YOKE- MANIFOLD	4	
23	1406411M00	STUD- EXHAUST	3	
29	0164200012	PLUG- TAPER	2	
30	0164800181	PLUG- WELCH	1	
32	2707633300	CONN.- WATER	1	
38	0821662210	STUD-	4	
42	089112081A	NUT	9	
43	089151381A	WASHER	5	
46	089313021A	PLUG- TAPER	2	
47	0893130410	PLUG- TAPER	1	

A15 NISSAN ENGINE — OIL PUMP ASSY.

OIL PUMP ASSY.

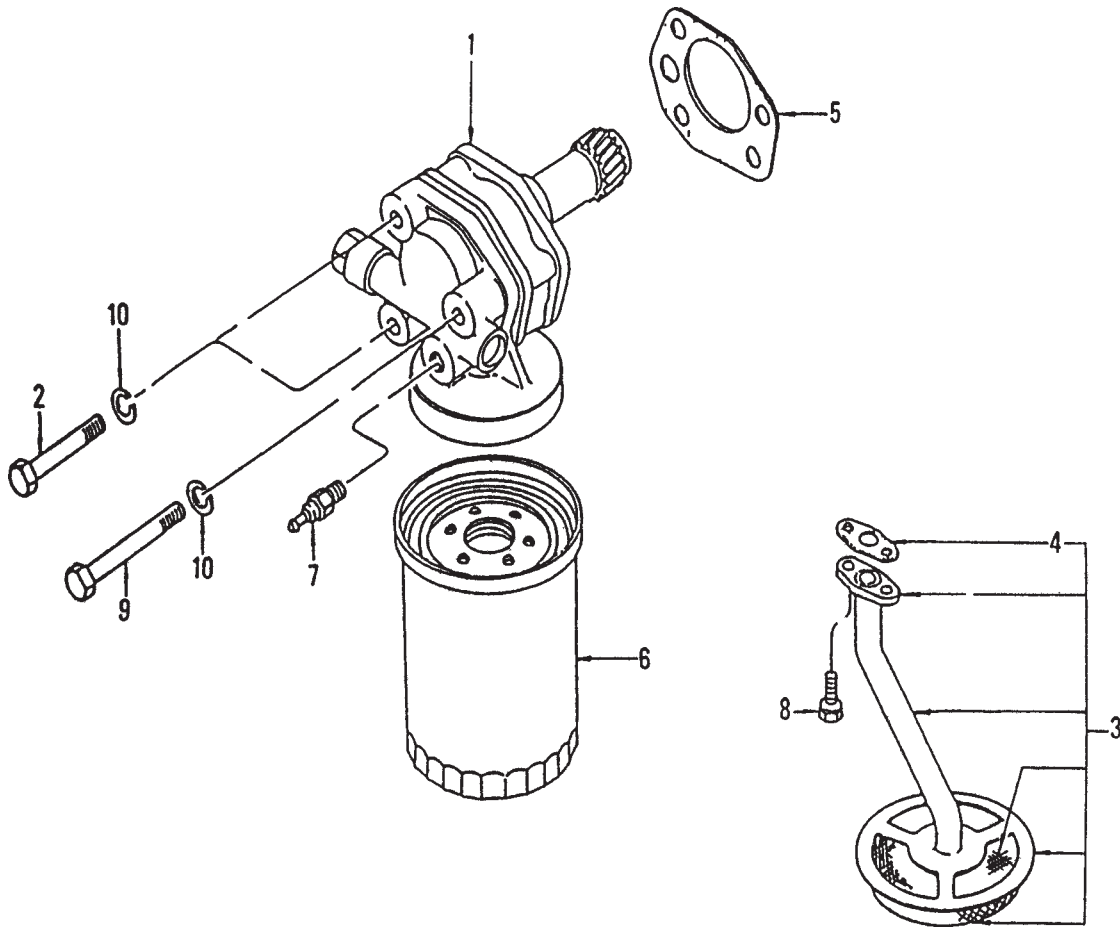

A15 NISSAN ENGINE — OIL PUMP ASSY.

OIL PUMP ASSY.

<u>NO.</u>	<u>PART NO.</u>	<u>PART NAME</u>	<u>QTY.</u>	<u>REMARKS</u>
1	15010M3001	PUMP ASSEMBLY OIL	1	
2	1503618000	BOLT- OIL PUMP	2	
3	1505005H00	STRAINER ASSEMBLY- OIL	1 INCLUDES ITEM W/*
4*	1505318000	GASKET- OIL STRAINER	1	
5	15066H1001	GASKET- OIL PUMP	1	
6	1520855Y00	ELEMENT ASSEMBLY- OIL	1	
7	2524089910	SWITCH- OIL PRESSURE	1	
8	081108201B	BOLT	2	
9	081108551A	BOLT	1	
10	089151381A	WASHER	3	

A15 NISSAN ENGINE — EXHAUST TUBE AND MUFFLER ASSY.

EXHAUST TUBE AND MUFFLER ASSY.

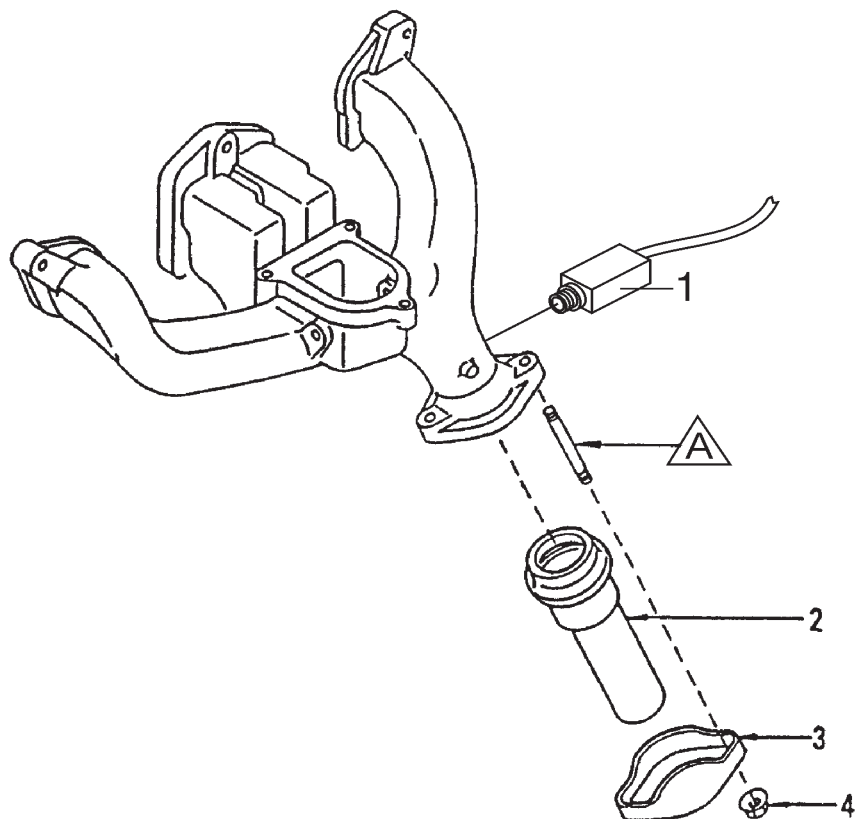

NOTE:
SEE ITEM 23
PAGE 114

A15 NISSAN ENGINE — EXHAUST TUBE AND MUFFLER ASSY.

EXHAUST TUBE AND MUFFLER ASSY.

<u>NO.</u>	<u>PART NO.</u>	<u>PART NAME</u>	<u>QTY.</u>	<u>REMARKS</u>
1	C282-355	SENSOR, EFI OXYGEN	1	
2	20011K4915	TUBE ASSEMBLY EXHAUST	1	
3	20601H7210	PLATE- FIXING	1	
4	20602S0600	NUT- FIXING TUBE END	3	

A15 NISSAN ENGINE — WATER PUMP ASSY.

WATER PUMP ASSY.

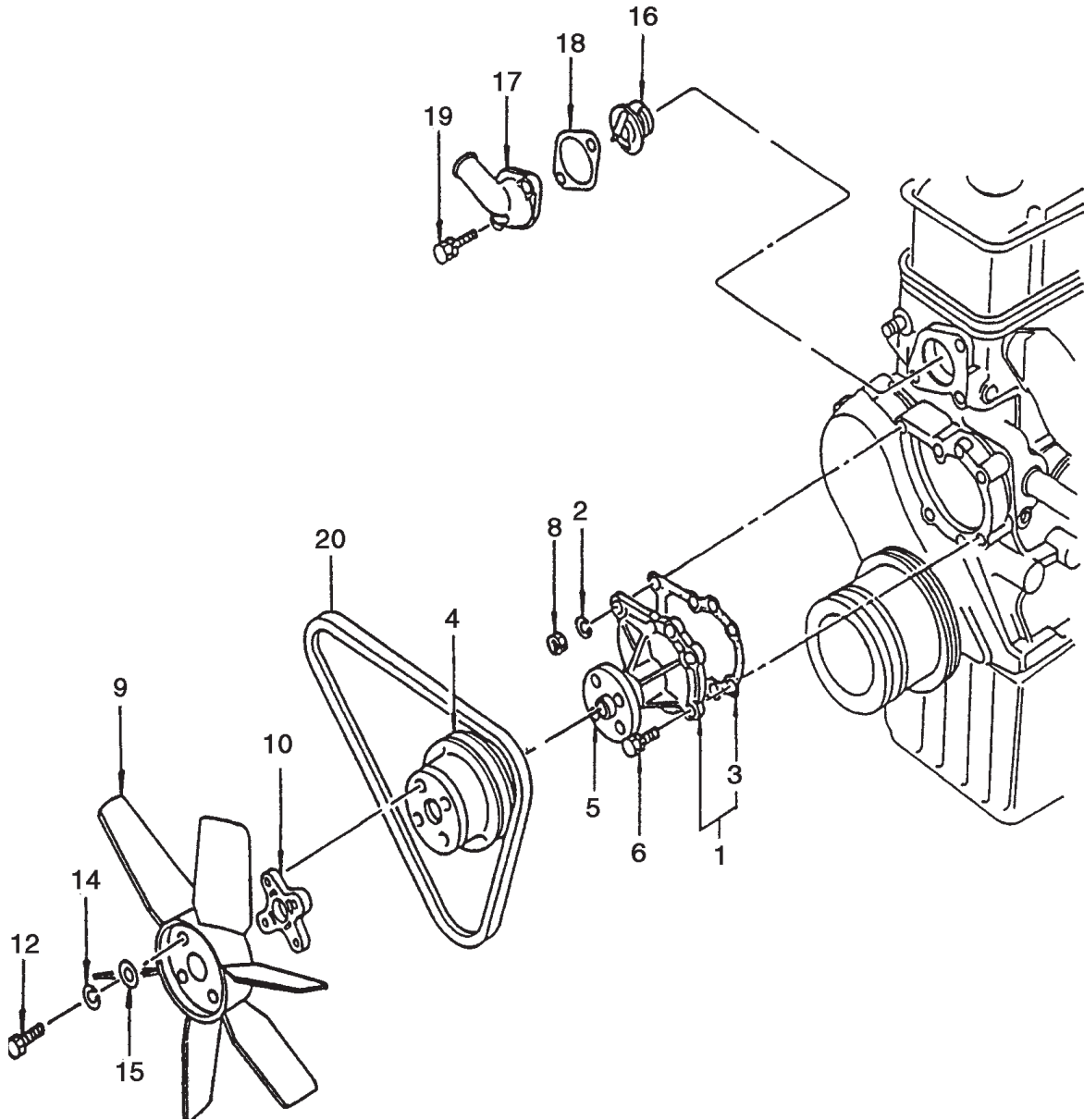

A15 NISSAN ENGINE — WATER PUMP ASSY.

WATER PUMP ASSY.

<u>NO.</u>	<u>PART NO.</u>	<u>PART NAME</u>	<u>QTY.</u>	<u>REMARKS</u>
1	21010K7700	WATER PUMP ASSY	1	INCLUDES ITEMS W/*
2	093400010P	WASHER	3	
3*	21014H1001	GASKET- WATER PUMP	1	
4	2105120500	PULLEY- FAN & PUMP	1	
5	21054K7700	HUB- PULLEY & PUMP	1	
6	081108501B	BOLT	2	
8	089111081A	NUT	3	
9	2106003W00	FAN- COOLING	1	
10	2106403W00	SPACER- FAN	1	
12	0812064062	BOLT	4	
16	21200G3100	THERMOSTAT STD. 180 DEGREES	1	
17	11060H5000	OUTLET- WATER	1	
18	1106218001	WASHER- JOINT	1	
19	0812083063	BOLT	2	
20	1172077702	V-BELT, FAN	1	

A15 NISSAN ENGINE — IGNITION SYSTEM ASSY.

IGNITION SYSTEM ASSY.

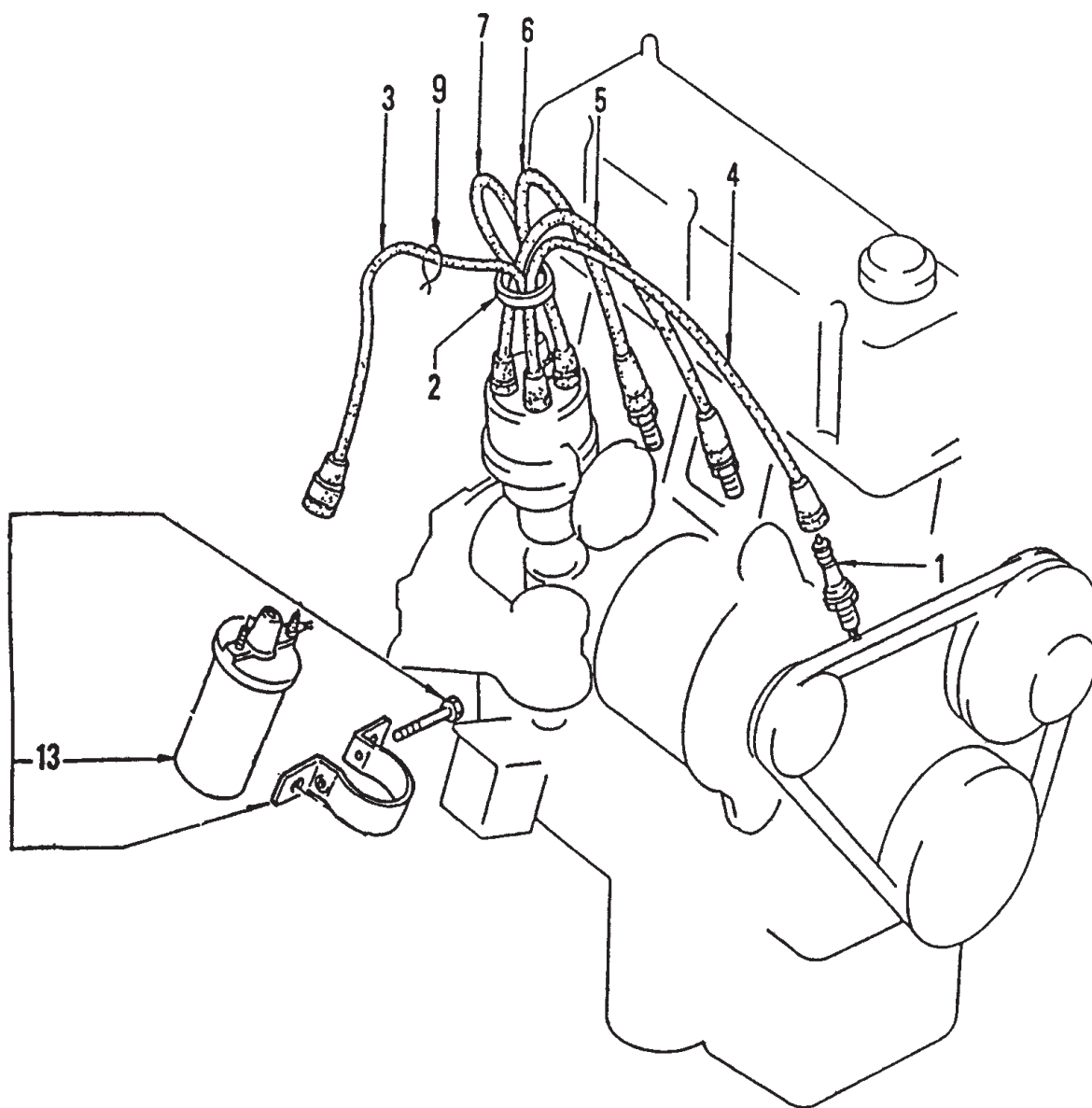

A15 NISSAN ENGINE — IGNITION SYSTEM ASSY.

IGNITION SYSTEM ASSY.

<u>NO.</u>	<u>PART NO.</u>	<u>PART NAME</u>	<u>QTY.</u>	<u>REMARKS</u>
1	22401M7714	PLUG- SPARK STD.	4	
2	2243110560	RING- HT. CABLE	1	
3	22450Y4000	CABLE ASSEMBLY COIL TO DIST.	1	
4	22451H5000	CABLE ASSEMBLY #1	1	
5	22452H5000	CABLE ASSEMBLY #2	1	
6	22453H5000	CABLE ASSEMBLY #3	1	
7	22454H5000	CABLE ASSEMBLY #4	1	
9	2401790004	CONNWIRE	1	
13	2246252A60	COIL IGNITION	1	

A15 NISSAN ENGINE — DISTRIBUTOR ASSY.

DISTRIBUTOR ASSY.

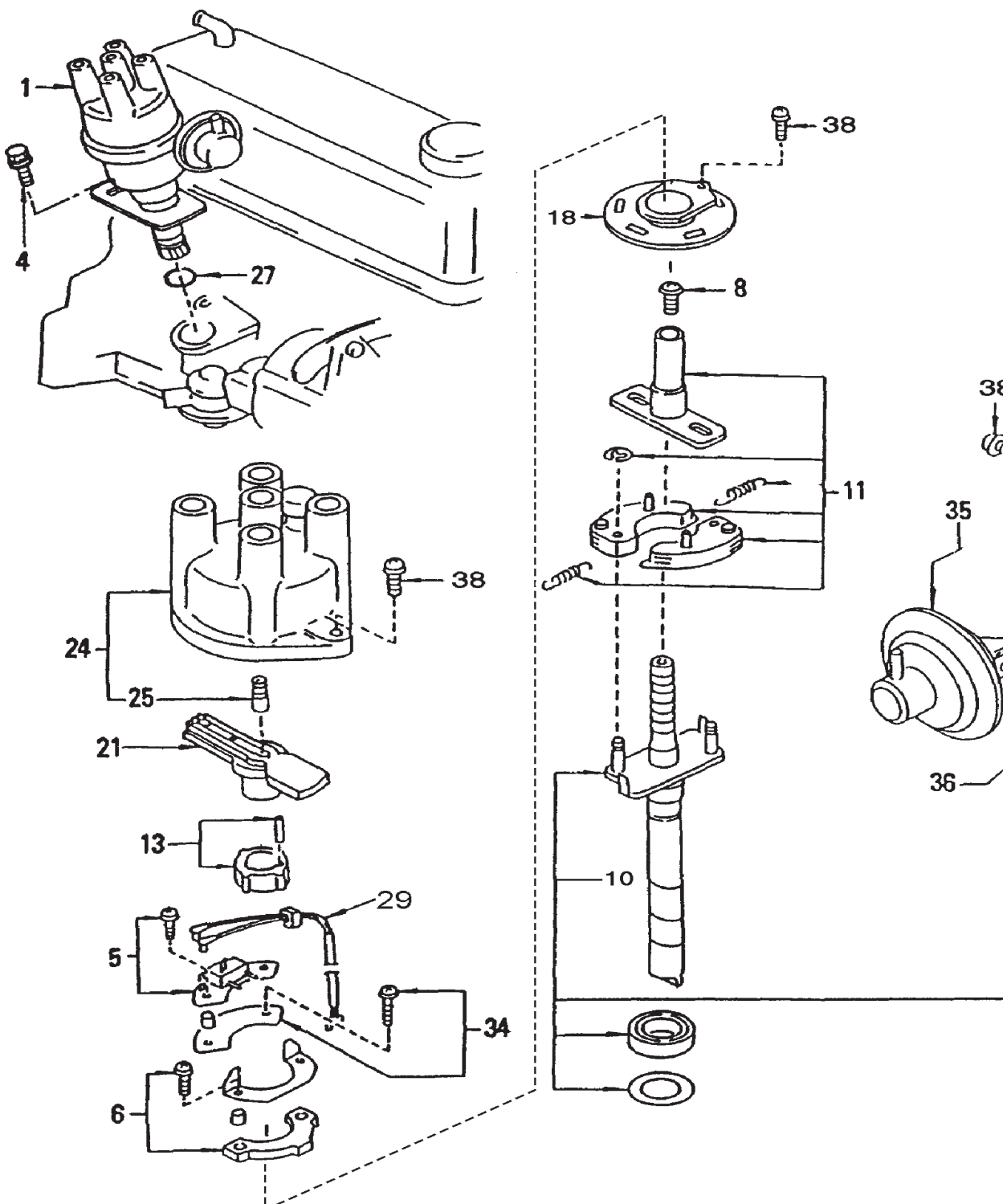

A15 NISSAN ENGINE — DISTRIBUTOR ASSY.

DISTRIBUTOR ASSY.

<u>NO.</u>	<u>PART NO.</u>	<u>PART NAME</u>	<u>QTY.</u>	<u>REMARKS</u>
1	22100G5110	DISTRIBUTOR ASSEMBLY	1	INCLUDES ITEMS W/%
2	0143600191	SCREW	1	
4	0143600221	SCREW	1	
5%	22020G5111	TRANSISTER- IGNITION UNIT	1	
6%	22023G5110	SEAT- SYNK.	1	
8%	2210414615	SCREW (4 X 8)	1	
10%	22108G5110	SHAFT ASSEMBLY	1	
11%	22109G5110	WEIGHT- GOVERNOR	1	INCLUDES ITEMS W/#
13%	2211577A11	SIGNAL ROTOR SET	1	
14%	22119M5610	COUPLING SET	1	
18%	2213677A11	PLATE ASSEMBLY BREAKER	1	
21%	2215723G15	ROTOR ASSEMBLY	1	
24%	2216278A10	CAP ASSEMBLY	1	INCLUDES ITEMS W/*
25%*	22165M5610	POINT ASSEMBLY- CARBON	1	
27	2218071200	O/RING	1	
29	22183G5111	LEAD WIRE	1	
30%	2218523G15	PACKING	1	
33%	2220122010	BOLT	1	
34%	2222977A11	PICK UP KIT	1	
35%	22301G5110	CONTROL ASSEMBLY- VAC.	1	
36%	22309H5010	TERMINAL ASSEMBLY	1	
38%	22750M0110	SCREW KIT	1	

A15 NISSAN ENGINE — ALTERNATOR ASSY.

ALTERNATOR ASSY.

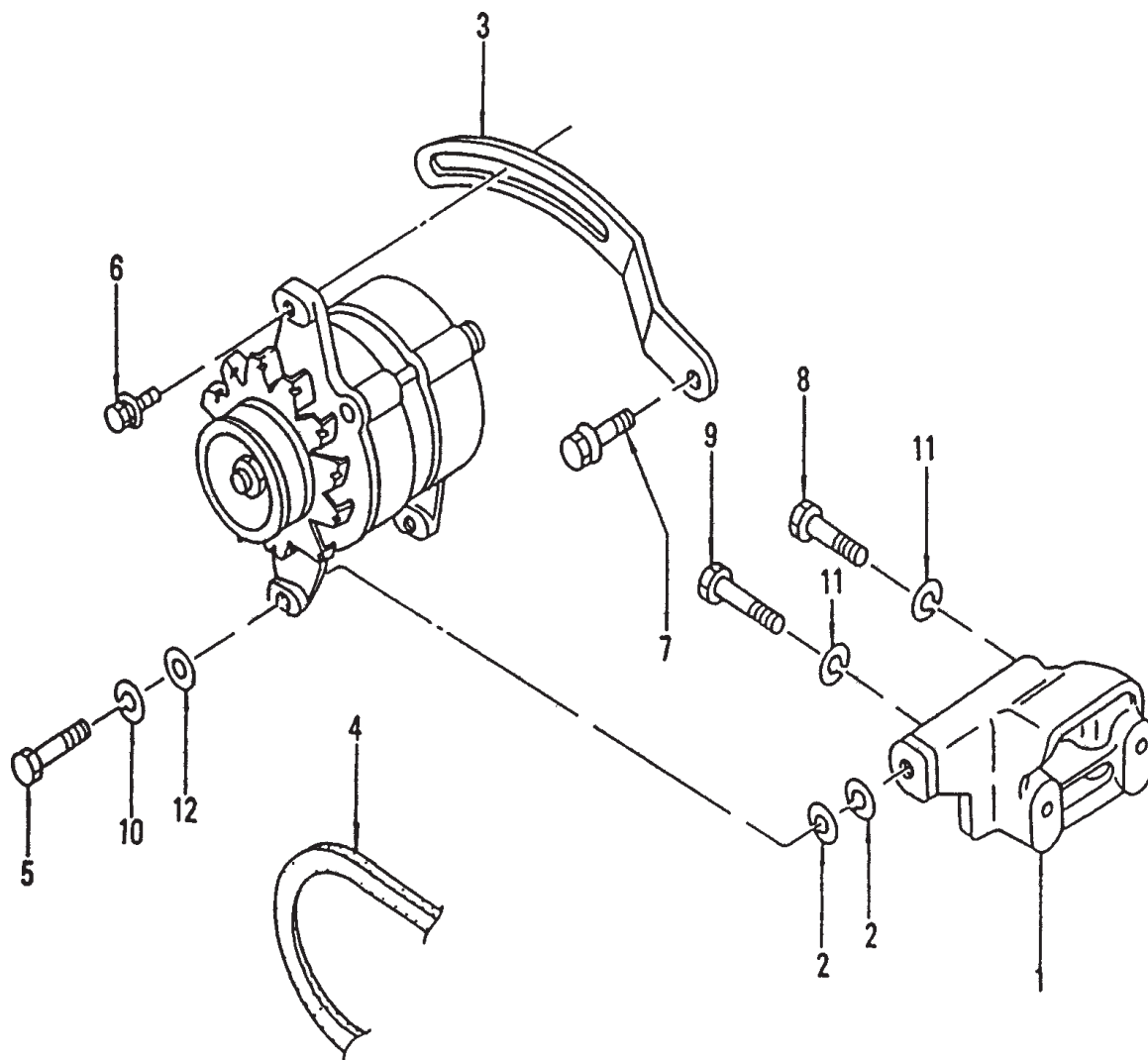

A15 NISSAN ENGINE — ALTERNATOR ASSY.

ALTERNATOR ASSY.

<u>NO.</u>	<u>PART NO.</u>	<u>PART NAME</u>	<u>QTY.</u>	<u>REMARKS</u>
1	11710H7201	BRACKET- ALTERNATOR	1	
2	1171321001	SHIM- ALTERNATOR	AR	
3	11715H7201	BAR ADJ- ALTERNATOR	1	
4	1172077702	BELT- FAN	1	
6	081810301A	BOLT	2	
4	0812082062	BOLT	1	
8	081710351A	BOLT	1	
9	081310421A	BOLT	1	
10	089151381A	WASHER	2	
11	089151401A	WASHER	2	
12	089154381A	WASHER PLAIN	2	
*	23300G5110	ALTERNATOR	1	

PAYMENT TERMS

Terms of payment for parts are net 30 days.

FREIGHT POLICY

All parts orders will be shipped collect or prepaid with the charges added to the invoice. All shipments are F.O.B. point of origin. Multiquip's responsibility ceases when a signed manifest has been obtained from the carrier, and any claim for shortage or damage must be settled between the consignee and the carrier.

MINIMUM ORDER

The minimum charge for orders from Multiquip is \$15.00 net. Customers will be asked for instructions regarding handling of orders not meeting this requirement.

RETURNED GOODS POLICY

Return shipments will be accepted and credit will be allowed, subject to the following provisions:

1. A Returned Material Authorization must be approved by Multiquip prior to shipment.
2. To obtain a Return Material Authorization, a list must be provided to Multiquip Parts Sales that defines item numbers, quantities, and descriptions of the items to be returned.
 - a. The parts numbers and descriptions must match the current parts price list.
 - b. The list must be typed or computer generated.
 - c. The list must state the reason(s) for the return.
 - d. The list must reference the sales order(s) or invoice(s) under which the items were originally purchased.
 - e. The list must include the name and phone number of the person requesting the RMA.
3. A copy of the Return Material Authorization must accompany the return shipment.
4. Freight is at the sender's expense. All parts must be returned freight prepaid to Multiquip's designated receiving point.
5. Parts must be in new and resalable condition, in the original Multiquip package (if any), and with Multiquip part numbers clearly marked.
6. The following items are not returnable:
 - a. Obsolete parts. (If an item is in the price book and shows as being replaced by another item, it is obsolete.)
 - b. Any parts with a limited shelf life (such as gaskets, seals, "O" rings, and other rubber parts) that were purchased more than six months prior to the return date.
 - c. Any line item with an extended dealer net price of less than \$5.00.
 - d. Special order items.
 - e. Electrical components.
 - f. Paint, chemicals, and lubricants.
 - g. Decals and paper products.
 - h. Items purchased in kits.
7. The sender will be notified of any material received that is not acceptable.
8. Such material will be held for five working days from notification, pending instructions. If a reply is not received within five days, the material will be returned to the sender at his expense.
9. Credit on returned parts will be issued at dealer net price at time of the original purchase, less a 15% restocking charge.
10. In cases where an item is accepted, for which the original purchase document can not be determined, the price will be based on the list price that was effective twelve months prior to the RMA date.
11. Credit issued will be applied to future purchases only.

PRICING AND REBATES

Prices are subject to change without prior notice. Price changes are effective on a specific date and all orders received on or after that date will be billed at the revised price. Rebates for price declines and added charges for price increases will not be made for stock on hand at the time of any price change.

Multiquip reserves the right to quote and sell direct to Government agencies, and to Original Equipment Manufacturer accounts who use our products as integral parts of their own products.

SPECIAL EXPEDITING SERVICE

A \$35.00 surcharge will be added to the invoice for special handling including bus shipments, insured parcel post or in cases where Multiquip must personally deliver the parts to the carrier.

LIMITATIONS OF SELLER'S LIABILITY

Multiquip shall not be liable hereunder for damages in excess of the purchase price of the item with respect to which damages are claimed, and in no event shall Multiquip be liable for loss of profit or good will or for any other special, consequential or incidental damages.

LIMITATION OF WARRANTIES

No warranties, express or implied, are made in connection with the sale of parts or trade accessories nor as to any engine not manufactured by Multiquip. Such warranties made in connection with the sale of new, complete units are made exclusively by a statement of warranty packaged with such units, and Multiquip neither assumes nor authorizes any person to assume for it any other obligation or liability whatever in connection with the sale of its products. Apart from such written statement of warranty, there are no warranties, express, implied or statutory, which extend beyond the description of the products on the face hereof.

Mechanical Drive Models

MAYCO PUMP, hereinafter referred to as “Manufacturer”, warrants each new Mayco Pump sold by the manufacturer to be free from defects in material and workmanship, under normal use and service, for a period of one year after the date of delivery to the original retail purchaser. Manufacturer will, at its option, replace or repair at a point designated by the Manufacturer any part or parts which shall appear to the satisfaction of the Manufacturer upon inspection at such point to have been defective in material or workmanship. This warranty does not obligate the Manufacturer to bear any transportation charges or labor charges in connection with the replacement or repair of the defective parts.

This warranty does not apply to any pump if attempts have been made to pump concrete materials which have separated, to any pump which has been repaired with other than Genuine Mayco Parts, nor to any pump which has been altered, repaired or used in such manner as to adversely affect its performance, nor to normal service or maintenance or where blockages have developed within the pump manifold or placing line or which has been operated in any other manner not recommended by the Manufacturer. Due to the abrasive nature of concrete, Mayco does not cover natural component wear.

THIS WARRANTY AND MANUFACTURER’S OBLIGATION HEREUNDER, IS IN LIEU OF ALL OTHER WARRANTIES, EXPRESS, IMPLIED OR STATUTORY AND ALL OTHER OBLIGATIONS OR LIABILITIES INCLUDING SPECIAL OR CONSEQUENTIAL DAMAGES OR CONTINGENT LIABILITIES ARISING OUT OF THE FAILURE OF ANY PUMP OR PART TO OPERATE PROPERLY, INCLUDING ANY WARRANTIES OF MERCHANTABILITY OR FITNESS FOR A PARTICULAR PURPOSE.

Hydraulic Drive Models

MAYCO PUMP, hereinafter referred to as “Manufacturer”, warrants each new Mayco Pump sold by the manufacturer to be free from defects in material and workmanship, under normal use and service, for a period of one year or 2000 hours after the date of delivery to the original retail purchaser. The Manufacturer will, at its option, replace or repair at a point designated by Manufacturer any part or parts which shall appear to the satisfaction of Manufacturer upon inspection at such point to have been defective in material or workmanship. This warranty does not obligate Manufacturer to bear any transportation charges or labor charges in connection with the replacement or repair of the defective parts.

This warranty does not apply to any pump if attempts have been made to pump concrete materials which have separated, to any pump which has been repaired with other than Genuine Mayco Parts, nor to any pump which has been altered, repaired or used in such manner as to adversely affect its performance, nor to normal service or maintenance or where blockages have developed within the pump manifold or placing line or which has been operated in any other manner not recommended by the Manufacturer. Due to the abrasive nature of concrete, Mayco does not cover natural component wear.

THIS WARRANTY AND MANUFACTURER’S OBLIGATION HEREUNDER, IS IN LIEU OF ALL OTHER WARRANTIES, EXPRESS, IMPLIED OR STATUTORY AND ALL OTHER OBLIGATIONS OR LIABILITIES INCLUDING SPECIAL OR CONSEQUENTIAL DAMAGES OR CONTINGENT LIABILITIES ARISING OUT OF THE FAILURE OF ANY PUMP OR PART TO OPERATE PROPERLY, INCLUDING ANY WARRANTIES OF MERCHANTABILITY OR FITNESS FOR A PARTICULAR PURPOSE.

OPERATION & PARTS MANUAL

HERE'S HOW TO GET HELP

PLEASE HAVE THE MODEL AND SERIAL
NUMBER *ON-HAND* WHEN CALLING

UNITED STATES

Multiquip Corporate Office

18910 Wilmington Ave. Tel. (800) 421-1244
Carson, CA 90746 Fax (800) 537-3927
Contact: mq@multiquip.com

Mayco Parts

800-306-2926 Fax: 800-672-7877
310-537-3700 Fax: 310-637-3284

Service Department

800-421-1244 Fax: 310-537-4259
310-537-3700

MQ Parts Department

800-427-1244 Fax: 800-672-7877
310-537-3700 Fax: 310-637-3284

Warranty Department

800-421-1244, Ext. 279 Fax: 310-537-1173
310-537-3700, Ext. 279

Technical Assistance

800-478-1244 Fax: 310-631-5032

MEXICO

MQ Cipsa

Carr. Fed. Mexico-Puebla KM 126.5 Tel. (52) 222-225-9900
Momoxpan, Cholula, Puebla 72760 Mexico Fax (52) 222-285-0420
Contact: pmastretta@cipsa.com.mx

CANADA

Multiquip

4110 Industriel Boul. Tel. (450) 625-2244
Laval, Quebec, Canada H7L 6V3 Fax (450) 625-8664
Contact: jmartin@multiquip.com

UNITED KINGDOM

Multiquip (UK) Limited Head Office

Hanover Mill, Fitzroy Street, Tel. 0161 339 2223
Ashton-under-Lyne, Fax 0161 339 3226
Lancashire OL7 0TL
Contact: sales@multiquip.co.uk

BRAZIL

Multiquip

Av. Evandro Lins e Silva, 840 - grupo 505 Tel. 011-55-21-3433-9055
Barra de Tijuca - Rio de Janeiro Fax 011-55-21-3433-9055
Contact: cnavarro@multiquip.com.br, srentes@multiquip.com.br

© COPYRIGHT 2006, MULTIQUIP INC.

Multiquip Inc, the MQ logo and the Mayco logo are registered trademarks of Multiquip Inc. and may not be used, reproduced, or altered without written permission. All other trademarks are the property of their respective owners and used with permission.

This manual MUST accompany the equipment at all times. This manual is considered a permanent part of the equipment and should remain with the unit if resold.

The information and specifications included in this publication were in effect at the time of approval for printing. Illustrations are based on the *Mayco C-30HDNI (Precision Fuel Injection) Concrete Pump*. Illustrations, descriptions, references and technical data contained in this manual are for guidance only and may not be considered as binding. Multiquip Inc. reserves the right to discontinue or change specifications, design or the information published in this publication at any time without notice and without incurring any obligations.

Your Local Dealer is:

