

PARTS MANUAL



***WHITEMAN* SERIES** **MODEL CA4HC** **WALK-BEHIND TROWEL** **(HONDA GX120 GASOLINE ENGINE)**

Revision #2 (08/16/07)

To find the latest revision of this
publication, visit our website at:
www.multiquip.com



THIS MANUAL MUST ACCOMPANY THE EQUIPMENT AT ALL TIMES.

P/N 21769



WARNING



CALIFORNIA — Proposition 65 Warning

Engine exhaust and some of its constituents, and some dust created by power sanding, sawing, grinding, drilling and other construction activities contains chemicals known to the State of California to cause cancer, birth defects and other reproductive harm. Some examples of these chemicals are:

- Lead from lead-based paints.
- Crystalline silica from bricks.
- Cement and other masonry products.
- Arsenic and chromium from chemically treated lumber.

Your risk from these exposures varies, depending on how often you do this type of work. To reduce your exposure to these chemicals: **ALWAYS** work in a well ventilated area, and work with approved safety equipment, such as dust masks that are specially designed to filter out microscopic particles.

CA4HC TROWEL— SILICOSIS/RESPIRATORY WARNINGS

WARNING



SILICOSIS WARNING

Grinding/cutting/drilling of masonry, concrete, metal and other materials with silica in their composition may give off dust or mists containing crystalline silica. Silica is a basic component of sand, quartz, brick clay, granite and numerous other minerals and rocks. Repeated and/or substantial inhalation of airborne crystalline silica can cause serious or fatal respiratory diseases, including silicosis. In addition, California and some other authorities have listed respirable crystalline silica as a substance known to cause cancer. When cutting such materials, always follow the respiratory precautions mentioned above.

WARNING

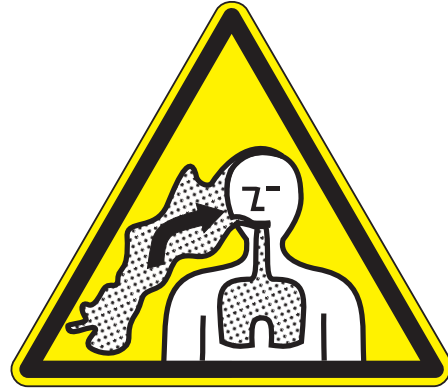

RESPIRATORY HAZARDS

Grinding/cutting/drilling of masonry, concrete, metal and other materials can generate dust, mists and fumes containing chemicals known to cause serious or fatal injury or illness, such as respiratory disease, cancer, birth defects or other reproductive harm. If you are unfamiliar with the risks associated with the particular process and/or material being cut or the composition of the tool being used, review the material safety data sheet and/or consult your employer, the material manufacturer/supplier, governmental agencies such as OSHA and NIOSH and other sources on hazardous materials. California and some other authorities, for instance, have published lists of substances known to cause cancer, reproductive toxicity, or other harmful effects.

Control dust, mist and fumes at the source where possible. In this regard use good work practices and follow the recommendations of the manufacturers or suppliers, OSHA/NIOSH, and occupational and trade associations. Water should be used for dust suppression when wet cutting is feasible. When the hazards from inhalation of dust, mists and fumes cannot be eliminated, the operator and any bystanders should always wear a respirator approved by NIOSH/MSHA for the materials being used.

CA4HC TROWEL—TABLE OF CONTENTS

MQ WHITEMAN CA4HC WALK-BEHIND TROWEL

Table Of Contents	4
Parts Ordering Procedures	5
Explanation of Codes in Remarks Column	6
Suggested Spare Parts	7

Component Drawings

Nameplate and Decals	8-9
Standard Handle Assembly	10-11
Foldable Handle Assembly	12-13
Basic Unit Assembly	14-15
Gearbox Assembly	16-17
Engine 4 HP Honda Assembly	18-19
Spider Assembly	20-21
Blades and Pans Assembly	22-23

Honda GX120 Engine

Air Cleaner (Dual) Assembly	24-25
Camshaft Assembly	26-27
Carburetor Assembly	28-29
Control Assembly	30-31
Crankcase Cover Assembly	32-33
Crankshaft Assembly	34-35
Cylinder Barrel Assembly	36-37
Cylinder Head Assembly	38-39
Fan Cover Assembly	40-41
Flywheel Assembly	42-43
Fuel Tank Assembly	44-45
Ignition Coil Assembly	46-47
Muffler Assembly	48-49
Piston Assembly	50-51
Recoil Starter Assembly	52-53
Gasket Kit Assembly	54-55
Labels	56-57

Terms and Condition Of Sale — Parts	58
---	----

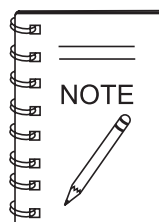

***Specifications and part numbers are
subject to change without notice.***

PARTS ORDERING PROCEDURES

Ordering parts has never been easier! Choose from three easy options:

Effective:
January 1st, 2006

www.multiquip.com



Order via Internet (Dealers Only):

Order parts on-line using Multiquip's SmartEquip website!

- View Parts Diagrams
- Order Parts
- Print Specification Information



If you have an MQ Account, to obtain a Username and Password, E-mail us at: parts@multiquip.com.

To obtain an MQ Account, contact your District Sales Manager for more information.

Goto www.multiquip.com and click on **Order Parts** to log in and save!

Use the **internet** and qualify for a **5% Discount** on *Standard orders* for all orders which include complete part numbers.*

Note: Discounts Are Subject To Change



Order via Fax (Dealers Only):

All customers are welcome to order parts via Fax.

Domestic (US) Customers dial:
1-800-6-PARTS-7 (800-672-7877)

Fax your order in and qualify for a **2% Discount** on *Standard orders* for all orders which include complete part numbers.*

Note: Discounts Are Subject To Change



Order via Phone: Domestic (US) Dealers Call:
1-800-427-1244

Non-Dealer Customers:

Contact your local Multiquip Dealer for parts or call 800-427-1244 for help in locating a dealer near you.



International Customers should contact their local Multiquip Representatives for Parts Ordering information.

When ordering parts, please supply:

- | | |
|---|--|
| <input type="checkbox"/> Dealer Account Number | <input type="checkbox"/> Specify Preferred Method of Shipment: |
| <input type="checkbox"/> Dealer Name and Address | <input checked="" type="checkbox"/> UPS/Fed Ex <input checked="" type="checkbox"/> DHL |
| <input type="checkbox"/> Shipping Address (if different than billing address) | <input type="checkbox"/> Priority One <input checked="" type="checkbox"/> Truck |
| <input type="checkbox"/> Return Fax Number | <input type="checkbox"/> Ground |
| <input type="checkbox"/> Applicable Model Number | <input type="checkbox"/> Next Day |
| <input type="checkbox"/> Quantity, Part Number and Description of Each Part | <input type="checkbox"/> Second/Third Day |



All orders are treated as *Standard Orders* and will ship the same day if received prior to 3PM PST.

WE ACCEPT ALL MAJOR CREDIT CARDS!

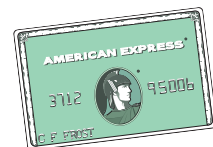

CA4HC TROWEL — EXPLANATION OF CODES IN REMARKS COLUMN

The following section explains the different symbols and remarks used in the Parts section of this manual. Use the help numbers found on the back page of the manual if there are any questions.

The contents and part numbers listed in the parts section are subject to change **without notice**. Multiquip does not guarantee the availability of the parts listed.

Sample Parts List:

NO.	PART NO.	PART NAME	QTY.	REMARKS
1	12345	BOLT	1	INCLUDES ITEMS W/*
2*		WASHER, 1/4 IN.		NOT SOLD SEPARATELY
2*	12347	WASHER, 3/8 IN. ...	1	MQ-45T ONLY
3	12348	HOSE	A/R	MAKE LOCALLY
4	12349	BEARING	1	S/N 2345B AND ABOVE

NO. Column

Unique Symbols - All items with same unique symbol (*, #, +, %, or >) in the number column belong to the same assembly or kit, which is indicated by a note in the "Remarks" column.

Duplicate Item Numbers - Duplicate numbers indicate multiple part numbers are in effect for the same general item, such as different size saw blade guards in use or a part that has been updated on newer versions of the same machine.

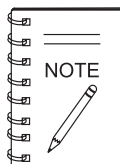

When ordering a part that has more than one item number listed, check the remarks column for help in determining the proper part to order.

PART NO. Column

Numbers Used - Part numbers can be indicated by a number, a blank entry, or TBD.

TBD (To Be Determined) is generally used to show a part that has not been assigned a formal part number at time of publication.

A blank entry generally indicates that the item is not sold separately or is not sold by Multiquip. Other entries will be clarified in the "Remarks" Column.

QTY. Column

Numbers Used - Item quantity can be indicated by a number, a blank entry, or A/R.

A/R (As Required) is generally used for hoses or other parts that are sold in bulk and cut to length.

A blank entry generally indicates that the item is not sold separately. Other entries will be clarified in the "Remarks" Column.

REMARKS Column

Some of the most common notes found in the "Remarks" Column are listed below. Other additional notes needed to describe the item can also be shown.

Assembly/Kit - All items on the parts list with the same unique symbol will be included when this item is purchased.

Indicated by:
"INCLUDES ITEMS W/(unique symbol)"

Serial Number Break - Used to list an effective serial number range where a particular part is used.

Indicated by:
"S/N XXXXX AND BELOW"
"S/N XXXX AND ABOVE"
"S/N XXXX TO S/N XXX"

Specific Model Number Use - Indicates that the part is used only with the specific model number or model number variant listed. It can also be used to show a part is NOT used on a specific model or model number variant.

Indicated by:
"XXXXX ONLY"
"NOT USED ON XXXX"

"Make/Obtain Locally" - Indicates that the part can be purchased at any hardware shop or made out of available items. Examples include battery cables, shims, and certain washers and nuts.

"Not Sold Separately" - Indicates that an item cannot be purchased as a separate item and is either part of an assembly/kit that can be purchased, or is not available for sale through Multiquip.

CA4HC TROWEL — SUGGESTED SPARE PARTS

CA4HC TROWEL 1 TO 3 UNITS WITH HONDA GX120GX120UTZX2 GASOLINE ENGINE.

1 to 3 Units

Qty.....	P/N	Description
2	20478	GRIP
1	21046	GASKET KIT
1	21047	BEARING KIT
2	9807354776	SPARK PLUG HONDA
2	17631ZH7003	TANK CAP (HONDA)
3	17211896000	AIR CLEANER ELEMENT (HONDA)
2	17218ZE2505	FILTER OUTER (HONDA)
1	21718	PITCH CABLE (STANDARD HANDLE)
1	1714	PITCH CABLE (QPHAFC HANDLE)
1	21724	THROTTLE CABLE (STANDARD HNDL)
1	21823	THROTTLE CABLE (QPHAFC HNDL)
1	10607	THRUST BEARING
1	10567	THRUST COLLAR
1	10639	WEAR PLATE
3	2343-1	V-BELT (A-25)
2	10065	GEARBOX LUBRICANT

CA4HC TROWEL — NAMEPLATE AND DECALS

NAMEPLATE AND DECALS



5

P/N 1848



7

CONTACT SERVICE DEPARTMENT



19

P/N: 13118



1

P/N: 1492 (STANDARD MODEL)



14

P/N 35168



12

P/N 2942 WHITE TEXT 13"



13

P/N 35137



17

P/N 20816



15

P/N 11092

8



P/N 36099 (ISO Blue)



16

P/N: 21455

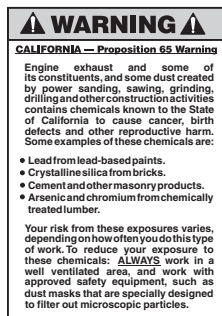

10

P/N 20525



18

P/N 21302

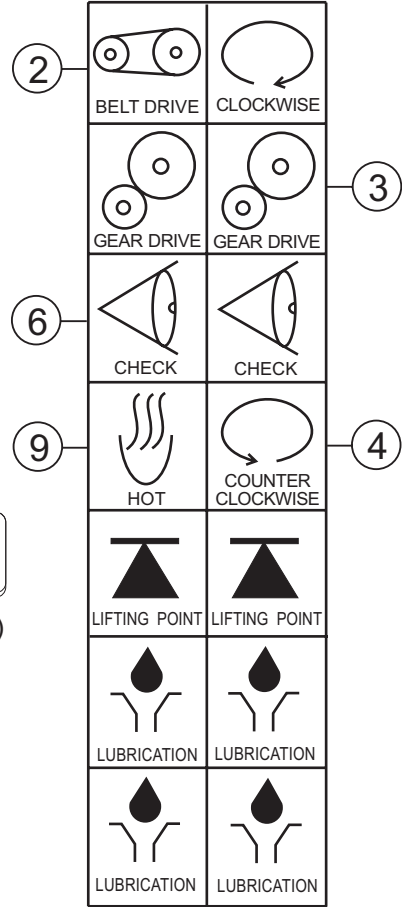

2

BELT DRIVE

CLOCKWISE

GEAR DRIVE

GEAR DRIVE

6

CHECK

CHECK

9

HOT

COUNTER CLOCKWISE

LIFTING POINT

LIFTING POINT

LUBRICATION

LUBRICATION

LUBRICATION

LUBRICATION

P/N: 11246



11

P/N 20936

CA4HC TROWEL — NAMEPLATE AND DECALS

NAMEPLATE AND DECALS

<u>NO.</u>	<u>PART NO.</u>	<u>PART NAME</u>	<u>QTY.</u>	<u>REMARKS</u>
1	1492	DECAL: FINISHER HANDLE	1	
2	11246	DECAL: BELT DRIVE	1	SAFETY ITEM
3	11246	DECAL: GEAR DRIVE	1	SAFETY ITEM
4	11246	DECAL: COUNTER CLOCKWISE	1	SAFETY ITEM
5	1848	DECAL: MQ/WHITEMAN POWER TROWEL	1	
6	11246	DECAL: CHECK OIL	1	
7		NAME PLATE	1	CONTACT MULTIQUIP PARTS DEPARTMENT
8	36099	DECAL: HELMET, SHOE AND GLOVE	1	SAFETY ITEM
9	11246	DECAL: HEAT	1	SAFETY ITEM
10	20525	DECAL: WARNING, CA PROP 65	1	SAFETY ITEM
11	20936	DECAL: MQ MULTIQUIP	3	
12	2942	DECAL: MQ WHITEMAN (WHITE TEXT)	1	
13	35137	DECAL: WARNING, READ MANUAL	1	SAFETY ITEM
14	35168	DECAL: WARNING, BLADE RISK	1	SAFETY ITEM
15	11092	DECAL: CE	1	
16	21455	DECAL: WARNING, LIFT/CRUSH HAZARD	1	SAFETY ITEM
17	20816	DECAL: MULTIQUIP	1	
18	21302	DECAL: WARNING KEEP GUARDS IN PLACE....	1	SAFETY ITEM

CA4HC TROWEL — STANDARD HANDLE ASSY.

STANDARD HANDLE ASSY.

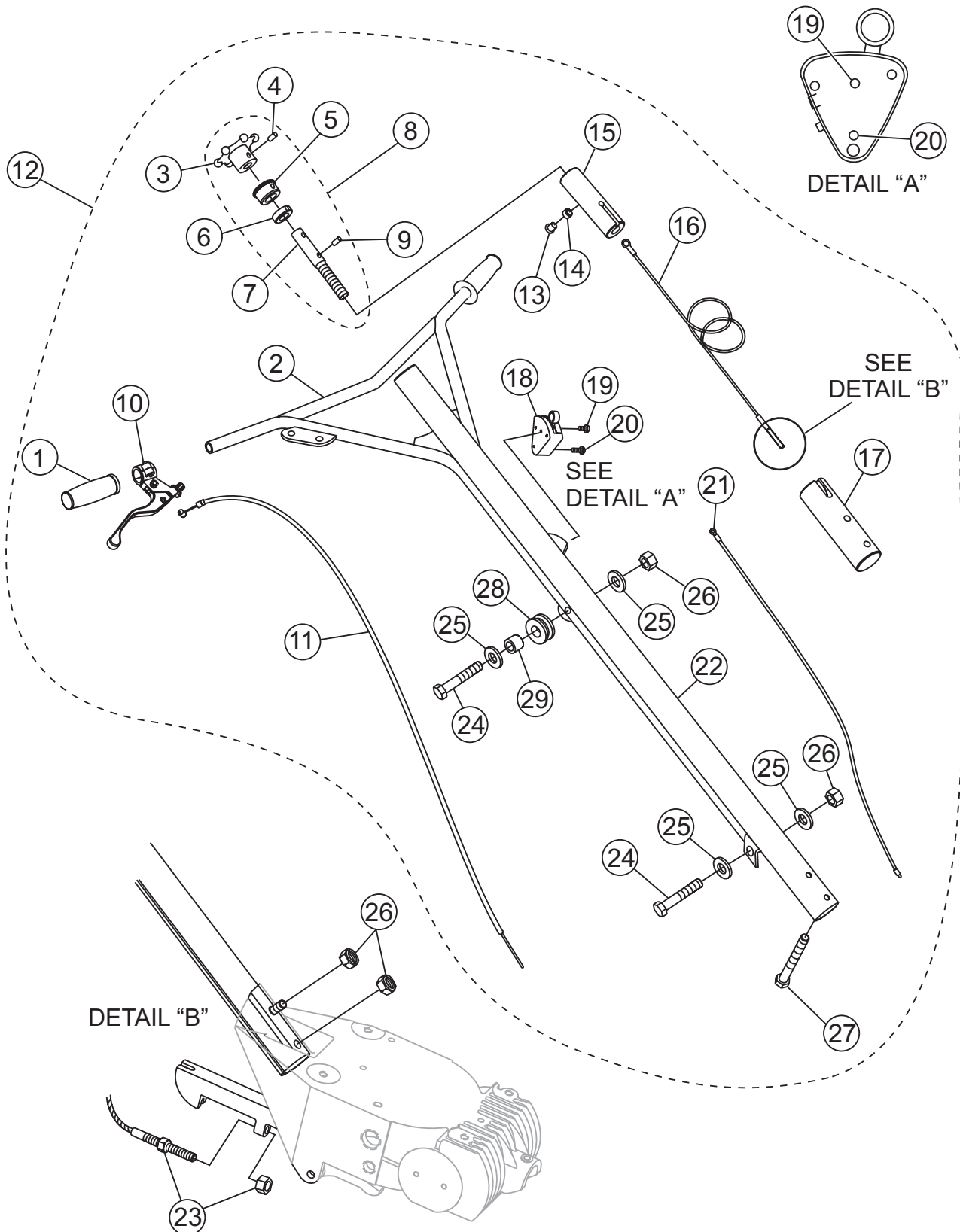

CA4HC TROWEL — STANDARD HANDLE ASSY.

STANDARD HANDLE

<u>NO.</u>	<u>PART NO.</u>	<u>PART NAME</u>	<u>QTY.</u>	<u>REMARKS</u>
1	20478	GRIP, HANDLE	2	
2	21251	HANDLE	1	
3*	21279	HAND WHEEL, PITCH CONTROL	1	
4*	1729	PIN, ROLL 3/16 X 1-1/4	1	
5*	21248	BEARING, TROWEL CONTROL	1	
6*	3615	COLLAR, SET 3/4 ID	1	
7*	21282	SHAFT, PITCH CONTROL	1	
8*	21279	HAND WHEEL ASSEMBLY, PITCH CONTROL.....	1	INCLUDES ITEMS W/*
9*	0122C	SCREW, SHS 3/8-16 X 1/2	1	
10	391512	LEVER, THROTTLE	1	
11	21724	CABLE, THROTTLE	1	
12	21711	HANDLE ASSEMBLY, STD WHITEMAN FIN	1	
13	0786	SCREW, BHC 1/4- 20 X 3/8 NYL PATCH, NP	1	
14	0786A	SPACER, SLIDE BLOCK GUIDE	1	
15	21249	SLIDE BLOCK, TROWEL CONTROL	1	
16	20285	CABLE, PITCH CONTROL	1	
17	21250	BLOCK SUPPORT	1	
18	20856	SWITCH ASSEMBLY, SAFETY STOP	1	
19	1602	SCREW, RHM 10-24 X 3/8.....	1	COMES WITH SWITCH ASM
20	20988	SCREW, FHSC PHILLIPS 8-32 X 1 1/4	1	
21	20514	WIRE ASSEMBLY, SAFETY STOP SWITCH	1	
22	21254	HANDLE TUBE	1	
23	0106	NUT, HEX JAM 5/16-18	2	
24	0169	SCREW, HHC 3/8-16 X 3.0	2	
25	10136	WASHER, FLAT 3/8 SAE	4	
26	10133	NUT, NYLOC 3/8-16	4	
27	21017	SCREW, HHC 3/8-16 X 3 1/4 FULL THRD GR 5	1	
28	1247	GROMMET, 1/4 X .875ID X 1-5/8OD	1	
29	1245	BUSHING	1	

CA4HC TROWEL — FOLDABLE HANDLE ASSY.

FOLDABLE HANDLE ASSY.

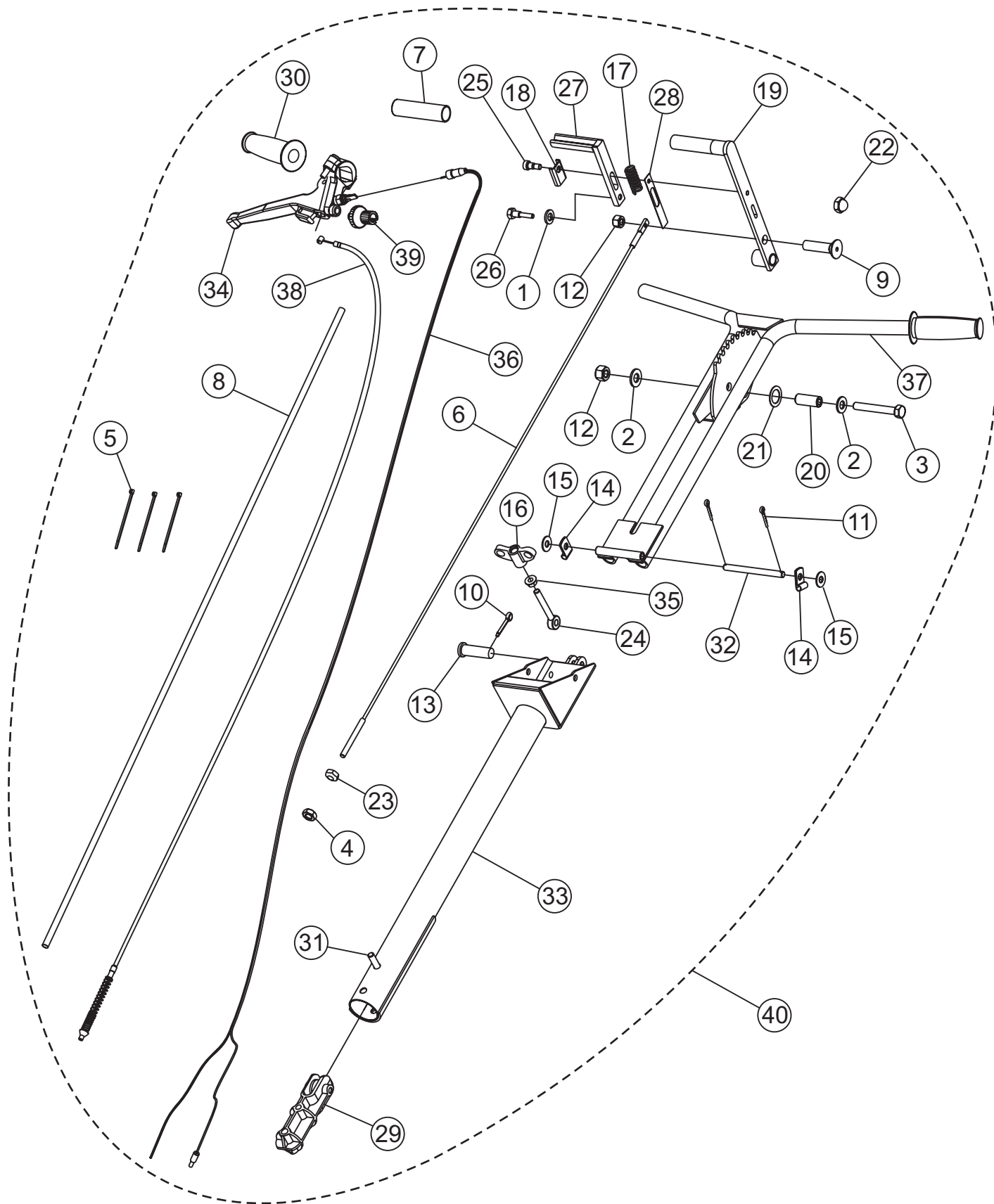

CA4HC TROWEL — FOLDABLE HANDLE ASSY.

FOLDABLE HANDLE ASSY.

<u>NO.</u>	<u>PART NO.</u>	<u>PART NAME</u>	<u>QTY.</u>	<u>REMARKS</u>
1	0161 C	WASHER, LOCK 5/16 MED	1	
2	0300 B	WASHER, FLAT SAE 5/16	2	
3	0669 A	SCREW, HHC 5/16 - 18 X 2-1/4	1	
4	1116	NUT, HEX JAM 5/16-18	1	
5	1662	TIE, CABLE TY-RAP BLACK	3	
6	1714	CABLE, PITCH CONTROL	1	
7	1724	GRIP, HANDLE PITCH	1	
8	60123	3/8" EXPANDABLE SLEEVING	1	
9	3164	SCREW, FHSC 1/4 - 20 X 1/2 NO PLATE	1	
10	3216	PIN, COTTER 1/8D X 1.00	1	
11	5117	PIN, COTTER 1/16D X 1/2	2	
12	5283	NUT, NYLOC 5/16-18	2	
13	5291	PIN, CLEVIS 3/8 X 1-1/8	1	
14	8128	CLAMP, HOSE SUPPORT 5/16	2	
15	10136	WASHER, FLAT 3/8 SAE	2	
16	10651	TEE HANDLE	1	
17	10654	SPRING, LATCH RETURN	1	
18	10655	COVER, SPRING	1	
19	10657	CONTROL HANDLE	1	
20	10658	TUBE, CONTROL HANDLE SUPPORT	1	
21	10660	SHIM, 1.125 O.D. X .75 I.D. X .031	1	
22	10676	NUT, ACORN 5/16 - 18	1	
23	10698	NUT, 5/16 - 18 - CONICAL	1	
24	10701	BOLT, SWING	1	
25	3910382	SCREW, SHLDR 3/8D X 3/8L 5/16-1 SCKT HD	1	
26	10878	BOLT, QP LATCHING	1	
27	10881	LATCHING BAR	1	
28	11015	STRIP, HANDLE SPACER	1	
29	20280	BLOCK, PITCH CONTROL	1	
30	20478	GRIP, HANDLE	2	
31	21017	SCREW, HHC 3/8-16 X 3 1/4 FULL THRD GR 5	1	
32	21758	PIN, HINGE HANDLE	1	
33	21779	HANDLE, LOWER	1	
34	21780	THROTTLE, MAGURA MODEL 90 W/KILL SW	1	
35	21781	NUT, FLG'D HEX 3/8 - 16 PLTD	1	
36	21785	KILL SWITCH HARNESS, MAGURA MODEL 90	1	
37	21788	HANDLE, UPPER	1	
38	21823	CABLE, MAGURA MODEL 90 CONTROL LEVER	1	
39	21824	ADJUSTER, W/THUMB WHEEL	1	
40	21786	HANDLE ASSY, QPHAFC	1	

CA4HC TROWEL — BASIC UNIT ASSY.

BASIC UNIT ASSY.

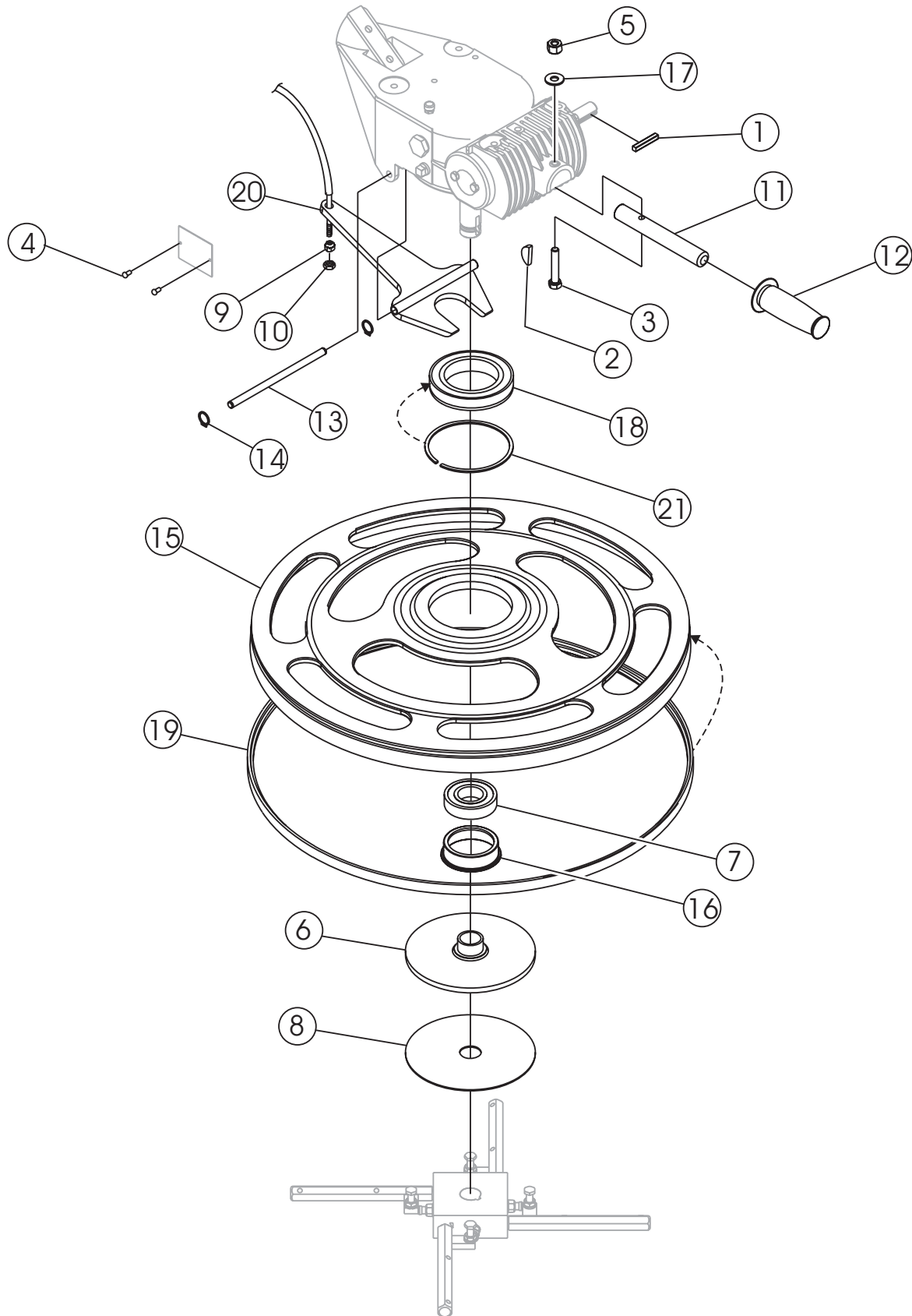

CA4HC TROWEL — BASIC UNIT ASSY.

BASIC UNIT ASSY.

<u>NO.</u>	<u>PART NO.</u>	<u>PART NAME</u>	<u>QTY.</u>	<u>REMARKS</u>
1	0627	KEY, INPUT SHAFT SQUARE	1	
2	1139	KEY, WOODRUFF #810	1	
3	1207	SCREW, HHC 5/16 - 18 X 1-3/4	1	
4	4014	SCREW, 2-3/16 P-K TYPE U DRIVE	2	
5	10024	NUT, NYLOC 1/4 - 20	1	
6	10567	THRUST COLLAR	1	
7	10607	THRUST BEARING	1	
8	10639	WEAR PLATE	1	
9	10698	NUT, ADJUSTING 5/16- 18	1	
10	1116	NUT, BRASS JAM 5/16- 18	1	
11	21735	LIFT HANDLE	1	
12	20478	GRIP, HANDLE	1	
13	20801	YOKE PIN	1	
14	20802	SNAP RING	2	
15	21433	RING, ROTATING GUARD	1	
16	21434	SLEEVE, PITCH	1	
17	25334	WASHER, FLAT 1/4 USS	1	
18	21441	BEARING, 2.9375 I.D. 4.527 O.D.	1	
19	21443	BELT, CLEAR URETHANE	1	
20	21477	YOKE	1	
21	21480	RING, RETAINING	1	

CA4HC TROWEL — GEARBOX ASSY.

GEARBOX ASSY.

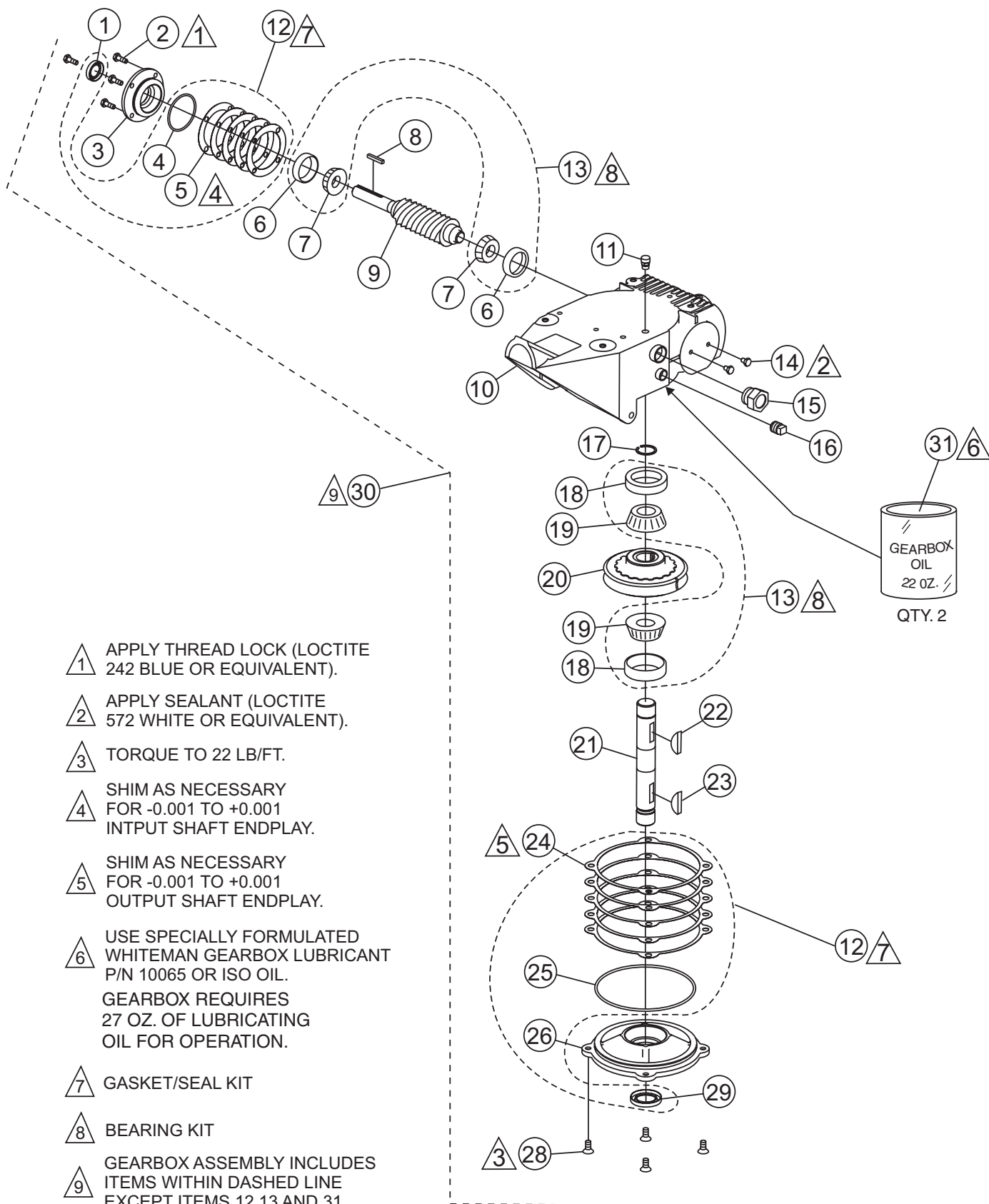

▲ 1 APPLY THREAD LOCK (LOCTITE 242 BLUE OR EQUIVALENT).

▲ 2 APPLY SEALANT (LOCTITE 572 WHITE OR EQUIVALENT).

▲ 3 TORQUE TO 22 LB/FT.

▲ 4 SHIM AS NECESSARY FOR -0.001 TO +0.001 INPUT SHAFT ENDPLAY.

▲ 5 SHIM AS NECESSARY FOR -0.001 TO +0.001 OUTPUT SHAFT ENDPLAY.

▲ 6 USE SPECIALLY FORMULATED WHITEMAN GEARBOX LUBRICANT P/N 10065 OR ISO OIL. GEARBOX REQUIRES 27 OZ. OF LUBRICATING OIL FOR OPERATION.

▲ 7 GASKET/SEAL KIT

▲ 8 BEARING KIT

▲ 9 GEARBOX ASSEMBLY INCLUDES ITEMS WITHIN DASHED LINE EXCEPT ITEMS 12, 13 AND 31

CA4HC TROWEL — GEARBOX ASSY.

GEARBOX ASSY.

<u>NO.</u>	<u>PART NO.</u>	<u>PART NAME</u>	<u>QTY.</u>	<u>REMARKS</u>
1%*	0753	SEAL, OIL NATIONAL	1	
2%	0131 A	SCREW, HHC 1/4-20 X 3/4	4	
3%	12876	FLANGE, INPUT SHAFT	1	
4%*	20395	RING, O -2" BUNA N	1	
5%*	20397	SHIM, INPUT 0.002 THICK	1	
5%*	20398	SHIM, INPUT 0.003 THICK	1	
5%*	20399	SHIM, INPUT 0.005 THICK	1	
5%*	20400	SHIM, INPUT 0.010 THICK	1	
5%*	20401	SHIM, INPUT 0.020 THICK	1	
6%#	21466	BEARING, CUP, TIMKEN	2	
7%#	20465	BEARING, CONE, TIMKEN	2	
8%	0627	KEY, SQUARE 3/16 X 1 1/4	1	
9%	1851	GEAR, WORM & SHAFT ASSY.	1	
10%	12874	CASE, GEAR WORM MACHINED	1	
11%	21218	VENT, AIR	1	
12	21046	GASKET/SEAL KIT	1	INCLUDES ITEMS W/*
13	21047	BEARING KIT	1	INCLUDES ITEMS W/ #
14%	20476	SCREW, HHC 1/4-28 X 3/8	2	
15%	21033	SIGHT GLASS, 3/4 NPT STEEL-NO BALL	1	
16%	0121 A	FITTING, PLUG 3/8 MP SQ HEAD	1	
17%	1138	RING, SNAP, TRUARC 5100-112	1	
18%#	20475	BEARING, CUP TIMKEN	2	
19%#	20474	BEARING, CONE TIMKEN	2	
20%	1140	GEAR, WORM, COMPOSITE	1	
21%	21435	SHAFT, OUTPUT	1	
22%	1139	KEY, WOODRUFF #810 HARDENED	1	
23%	1238	KEY, WOODRUFF #25	1	
24%*	20402	SHIM, OUTPUT 0.002 THICK	1	
24%*	20403	SHIM, OUTPUT 0.003 THICK	1	
24%*	20404	SHIM, OUTPUT 0.005 THICK	1	
24%*	20405	SHIM, OUTPUT 0.010 THICK	1	
24%*	20406	SHIM, OUTPUT 0.020 THICK	1	
25%*	20396	RING, O -254 BUNA N	1	
26%	12875	COVER, GEARBOX	1	
28%	20875	SCREW, FHSC 5/16-18 X 3/4	4	
29%*	0254	SEAL, OIL, NATIONAL	1	
30	21436	GEARBOX ASSY.	1	INCLUDES ITEMS W/ %
31	10065	GEARBOX OIL 22 OZ.	2	REQUIRES 28 OZ.

CA4HC TROWEL — ENGINE, 4 HP HONDA ASSY.

ENGINE, 4 HP HONDA ASSY.

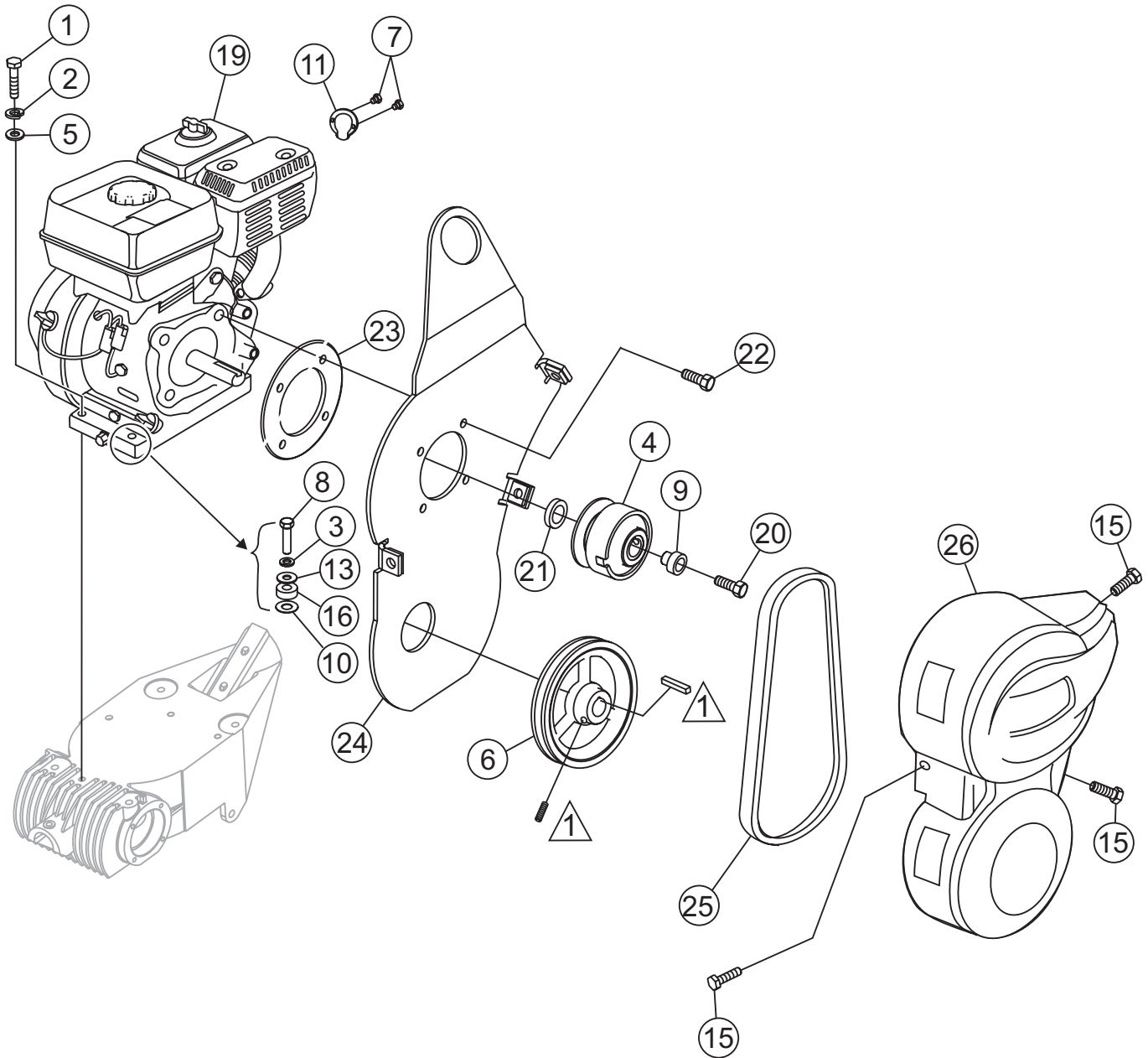

 COMES WITH PULLEY

CA4HC TROWEL — ENGINE, 4 HP HONDA ASSY.

ENGINE, 4 HP HONDA ASSY.

<u>NO.</u>	<u>PART NO.</u>	<u>PART NAME</u>	<u>QTY.</u>	<u>REMARKS</u>
1	0105	SCREW, HHC 5/16- 18 X 1-1/2	3	
2	0161 C	LOCK WASHER 5/16	3	
3	0166 A	LOCK WASHER 3/8	1	
4	0255	CLUTCH ASSEMBLY	1	
5	0300 B	FLAT WASHER 5/16	3	
6	0740	PULLEY AK-51 X 3/4	1	
7	1273	SCREW, HHST 3- 32 X 3/8	2	
8	1284	SCREW, HHC 3/8 -16 X 1-1/2	1	
9	1406	END PLUG, CLUTCH	1	
10	1733	WASHER, 1/2 X 1/32	1	
11	1834	DEFLECTOR, HONDA EXHAUST	1	
13	10136	FLAT WASHER 3/8	1	
15	12287	SCREW, THP 1/4 - 20 X 3/4 SS	3	
16	13351	WASHER, FLAT USS 3/8 EXT. THK.	1	
19	21387	ENGINE, 4 HP. HONDA GX120UTQX2	1	
20	21678	SCREW, FHSC 5/16 - 24 X 1-3/4	1	
21	21679	SPACER, 1" X .78 X 69L	1	
22	21911	SCREW, HHFS 5/16 - 24 X 1 GR5	4	
23	21915	SPACER, C M & J LIFTING BALE	1	
24	21927	BRACKET, W/LIFTING BALE ASSEMBLY	1	
25	2343-1	V-BELT, A-25	1	
26	30102-001	BELT GUARD, TROWEL	1	

CA4HC TROWEL — SPIDER ASSY.

SPIDER ASSY.

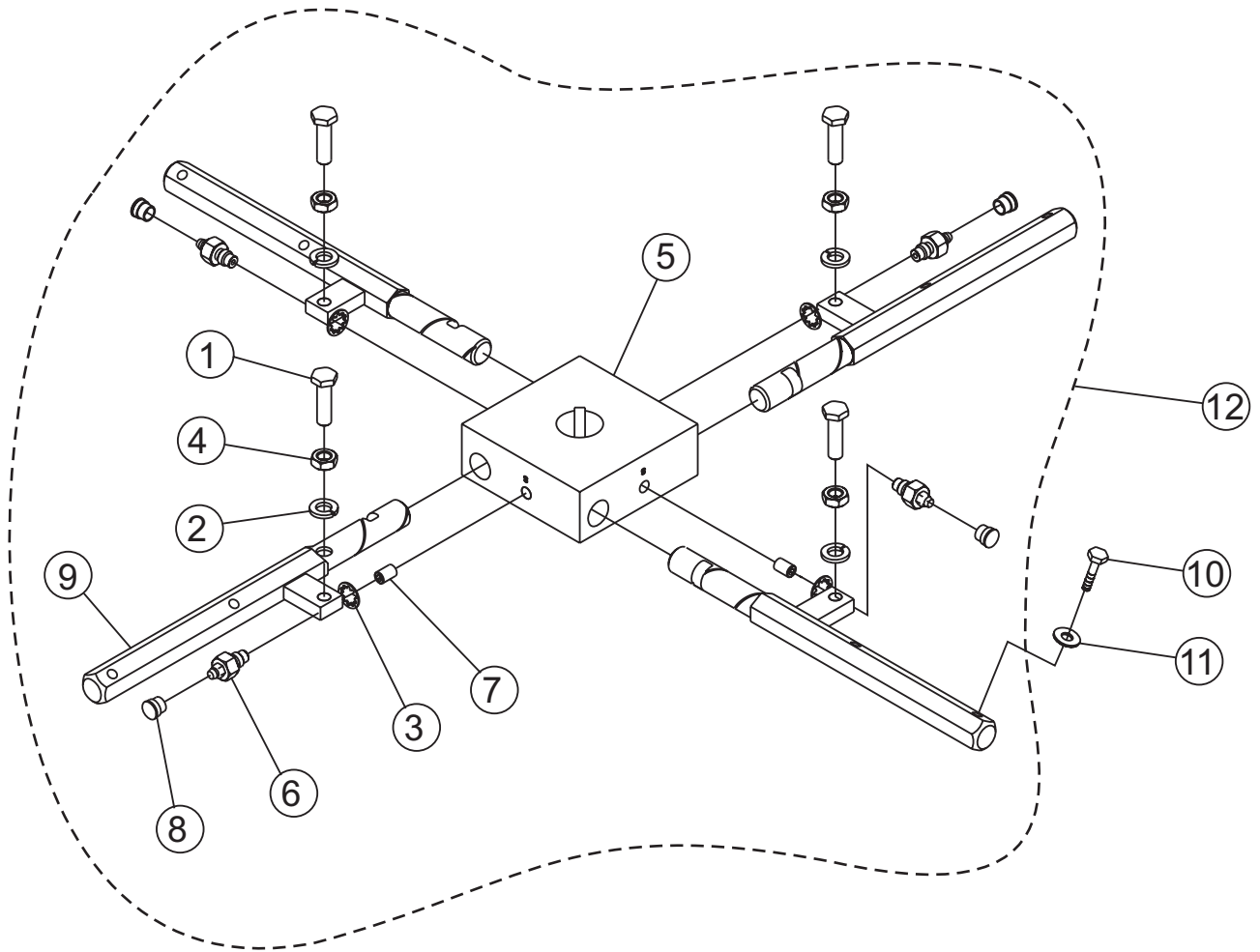

CA4HC TROWEL — SPIDER ASSY.

SPIDER ASSY.

<u>NO.</u>	<u>PART NO.</u>	<u>PART NAME</u>	<u>QTY.</u>	<u>REMARKS</u>
1	0164 B	SCREW, HHC 3/8- 16 X 1-1/4 F.T.	4	
2	0166 A	LOCK WASHER 3/8"	4	
3	1875	WASHER, LOCK 3/8 MED	4	
4	1876	NUT, JAM 3/8- 16	4	
5	10563	SPIDER	1	
6	10587	SCREW, RETAINING	4	
7	11299	SCREW, SHS 5/16- 18 X 9/16" CONE PT.	2	
8	1162 A	GREASE ZERK CAP	4	
9	10768	TROWEL ARM	4	
10	10790	SCREW, HHC M6- 1 X 30MM	8	
11	0181 B	LOCK WASHER 1/4"	8	
12	11860	SPIDER ASSEMBLY	1	

CA4HC TROWEL — BLADES & PAN ASSY.

BLADES & PAN ASSY.

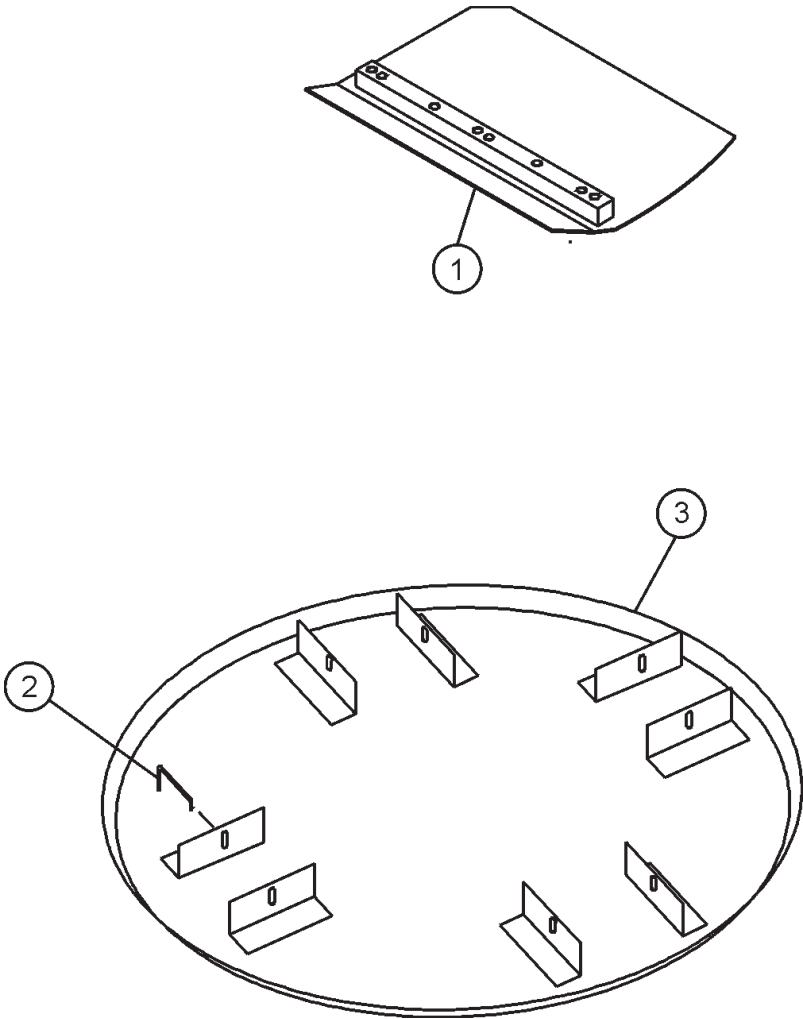

CA4HC TROWEL — BLADES & PAN ASSY.

BLADES & PAN ASSY.

<u>NO.</u>	<u>PART NO.</u>	<u>PART NAME</u>	<u>QTY.</u>	<u>REMARKS</u>
1		COMBO FLOAT & FINISH BLADE	4	CONTACT UNIT SALES DEPT./ACCESSORY ITEM
2		FLOAT DISC LATCH PIN	4	CONTACT UNIT SALES DEPT./ACCESSORY ITEM
3		FLOAT DISC	1	CONTACT UNIT SALES DEPT./ACCESSORY ITEM

HONDA GX120UTQX2 ENGINE — AIR CLEANER (DUAL) ASSY.

AIR CLEANER (DUAL) ASSY.

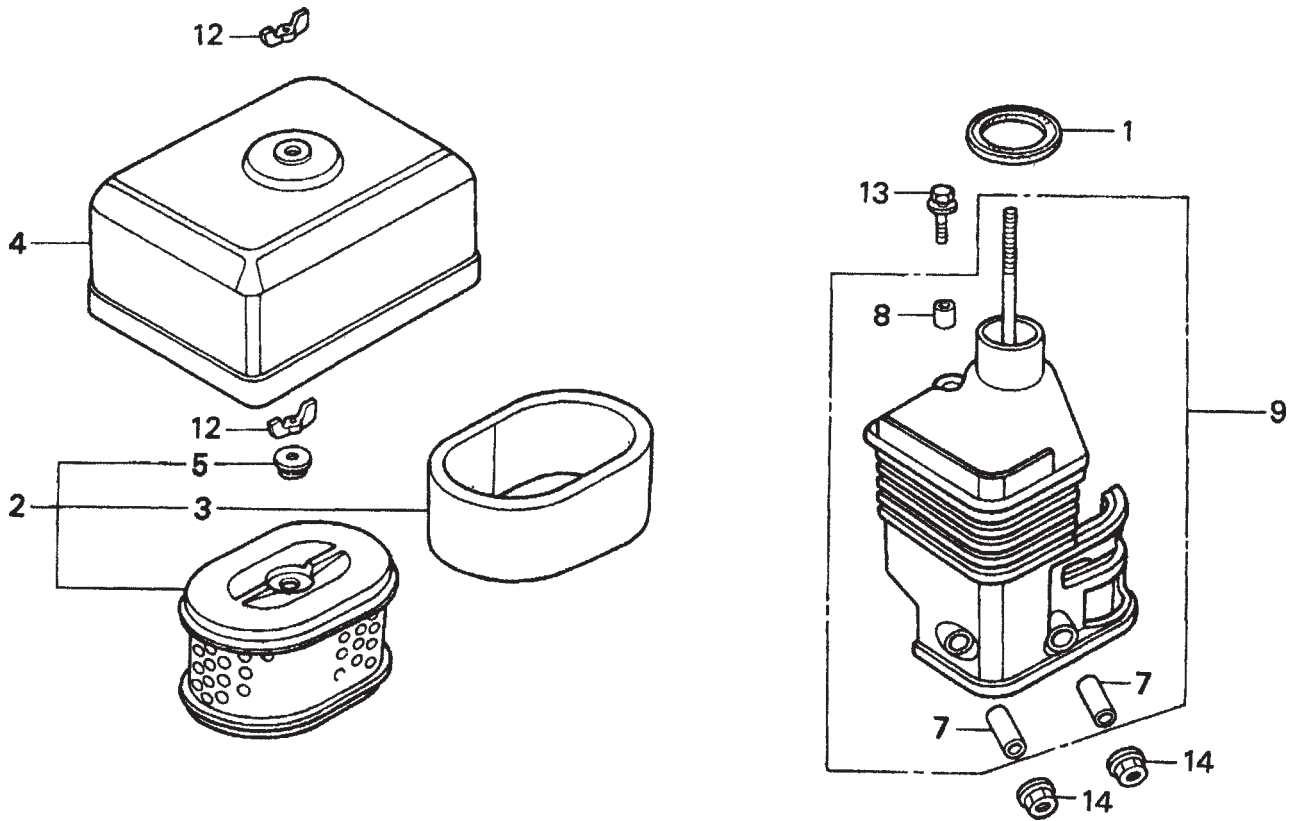

HONDA GX120UTQX2 ENGINE — AIR CLEANER (DUAL) ASSY.

AIR CLEANER (DUAL) ASSY.

<u>NO.</u>	<u>PART NO.</u>	<u>PART NAME</u>	<u>QTY.</u>	<u>REMARKS</u>
1	16271ZE1000	GASKET, ELBOW	1	
2	17210ZE0505	ELEMENT, AIR CLEANER (DUAL)	1	INCLUDES ITEMS W/*
3*	17218ZE0505	FILTER, OUTER	1	
4	17230ZE0820	COVER, AIR CLEANER (DUAL)	1	
5*	17232891000	GROMMET, AIR CLEANER	1	
7#	17238ZE0010	COLLAR, AIR CLEANER	2	
8#	17239ZE1000	COLLAR B, AIR CLEANER	1	
9	17410ZE0030	ELBOW, AIR CLEANER	1	INCLUDES ITEMS W/#
12	90325044000	WINGNUT, TOOL BOX SETTING	2	
13	957010602000	BOLT, FLANGE 6X20	1	
14	9405006000	NUT, FLANGE 6MM	2	

HONDA GX120UTQX2 ENGINE — CAMSHAFT ASSY.

CAMSHAFT ASSY.

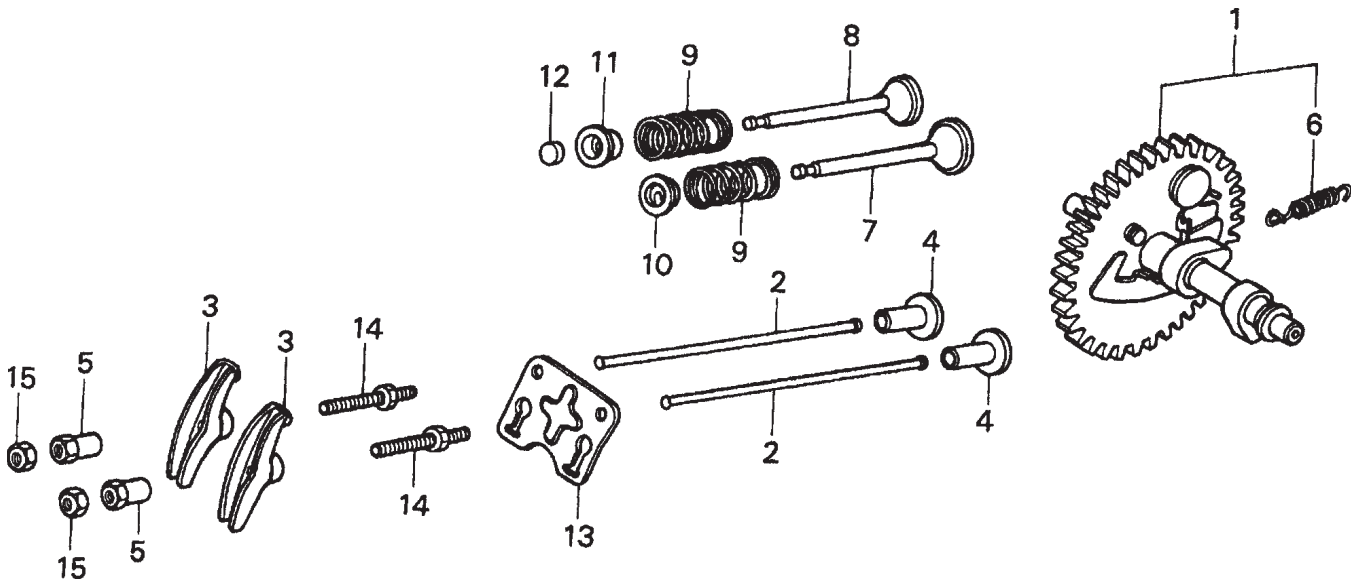

HONDA GX120UTQX2 ENGINE — CAMSHAFT ASSY.

CAMSHAFT ASSY.

<u>NO.</u>	<u>PART NO.</u>	<u>PART NAME</u>	<u>QTY.</u>	<u>REMARKS</u>
1	14100ZE0812	CAMSHAFT ASSEMBLY	1	INCLUDES ITEMS W/*
2	14410ZE0010	ROD, PUSH	2	
3	14431ZE1000	ARM, VALVE ROCKER	2	
4	14441ZE1010	LIFTER, VALVE	2	
5	14451ZE1013	PIVOT, ROCKER ARM	2	
6*	14568ZE1000	SPRING, WEIGHT RETURN	1	
7	14711ZF0010	VALVE, IN.	1	
8	14721ZH7810	VALVE, EX. (HAUST)	1	
9	14751ZF1000	SPRING, VALVE	2	
10	14771ZE1000	RETAINER, IN. VALVE SPRING	1	
11	14773ZE1000	RETAINER, EX. VALVE SPRING	1	
12	14781ZE1000	ROTATOR, VALVE	1	
13	14791ZE0010	PLATE, PUSH ROD GUIDE	1	
14	90012ZE0010	BOLT, PIVOT 8MM	2	
15	90206ZE1000	NUT, PIVOT ADJ.	2	

HONDA GX120UTQX2 ENGINE — CARBURETOR ASSY.

CARBURETOR ASSY.

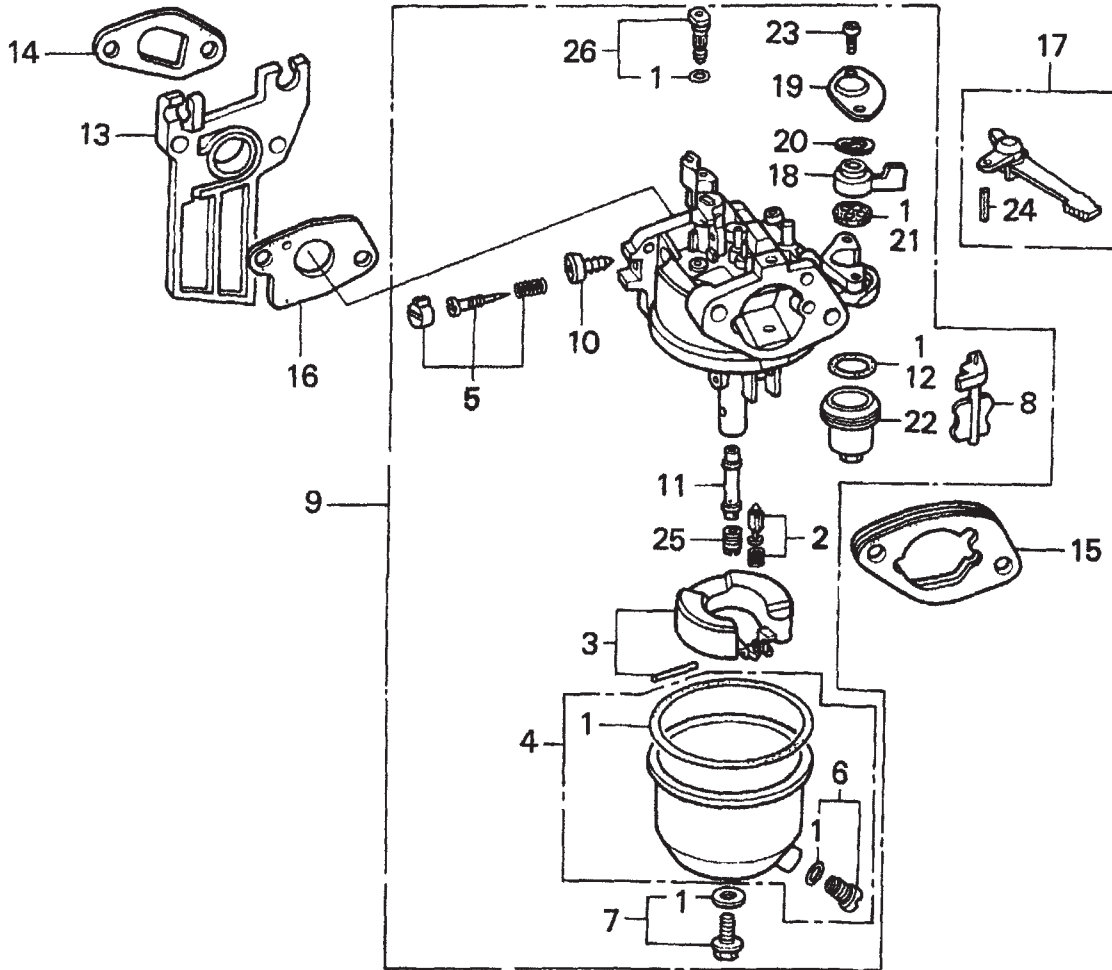

HONDA GX120UTQX2 ENGINE — CARBURETOR ASSY.

CARBURETOR ASSY.

<u>NO.</u>	<u>PART NO.</u>	<u>PART NAME</u>	<u>QTY.</u>	<u>REMARKS</u>
1*	16010ZE1812	GASKET SET	1	
2*	16011ZE0005	VALVE SET, FLOAT	1	
3*	16013ZE0005	FLOAT SET	1	
4*	16015ZE1811	CHAMBER SET, FLOAT	1	
5*	16016ZH7W01	SCREW SET	1	
6*	16024ZE1811	SCREW SET, DRAIN	1	
7*	16028ZE0005	SCREW SET B	1	
8*	16044ZE0005	CHOKE SET	1	
9	16100ZH8W51	CARBURETOR ASSY. (BE65B B)	1 INCLUDES ITEMS W/*
10*	16124ZE0005	SCREW, THROTTLE STOP	1	
11*	16166ZH7W50	NOZZLE, MAIN	1	
12*	16173001004	O-RING	1	
13	16211ZE1000	INSULATOR, CARBURETOR	1	
14	16212ZH7800	GASKET, INSULATOR	1	
15	16220ZE1020	SPACER, CARBURETOR	1	
16	16221ZH8801	GASKET, CARBURETOR	1	
17	16610ZE1000	LEVER, CHOKE (STD)	1 INCLUDES ITEMS W/#
18*	16953ZE1812	LEVER, VALVE	1	
19*	16954ZE1811	PLATE, LEVER SETTING	1	
20*	16956ZE1811	SPRING, VALVE LEVER	1	
21*	16957ZE1812	GASKET, VALVE	1	
22*	16967ZE0811	CUP, FUEL STRAINER	1	
23*	93500030080G	SCREW, PAN (3 X 6)	2	
24#	9430520122	PIN, SPRING (2 X 12)	1	
25	99101ZH80550	JET, MAIN (#55) OPTIONAL	1	
25	99101ZH80580	JET, MAIN (#58) OPTIONAL	1	
25*	99101ZH80600	JET, MAIN (#60)	1	
26*	99204ZE00350	JET, SET, PILOT (#35)	1	

HONDA GX120UTQX2 ENGINE — CONTROL ASSY.

CONTROL ASSY.

<u>NO.</u>	<u>PART NO.</u>	<u>PART NAME</u>	<u>QTY.</u>	<u>REMARKS</u>
2	16500ZH7820	CONTROL ASSEMBLY	1	INCLUDES ITEMS W/*
4	16551ZE0010	ARM, GOVERNOR	1	
5	16555ZE0000	ROD, GOVERNOR	1	
6	16561ZE0020	SPRING, GOVERNOR	1	
7	16562ZE0020	SPRING, THROTTLE RETURN	1	
8*	16571ZH7000	LEVER, CONTROL	1	
9*	16574ZE1000	SPRING, LEVER	1	
10*	16575ZH8000	WASHER, CONTROL LEVER	1	
11*	16576891000	HOLDER, CABLE	1	
12*	16578ZE1000	SPACER, CONTROL LEVER	1	
14*	16580ZH7810	BASE, CONTROL	1	
15*	16584883300	SPRING, CONTROL ADJUSTING	1	
16*	16592ZE1810	SPRING, CABLE RETURN	1	
18	90013883000	BOLT, FLANGE 6X12 (CT200)	1	
19	90015ZE5010	BOLT, GOVERNOR ARM	1	
20	90022888010	BOLT, FLANGE 6X20 (CT200)	1	
21*	90114SA0000	NUT, SELF- LOCK 6MM	1	
24*	93500050250H	SCREW, PAN 5X25	1	
25*	93500050160A	SCREW-WASHER (5X16)	1	
26	9405006000	NUT, FLANGE 6MM	1	

HONDA GX120UTQX2 ENGINE — CRANKCASE COVER ASSY.

CRANKCASE COVER ASSY.

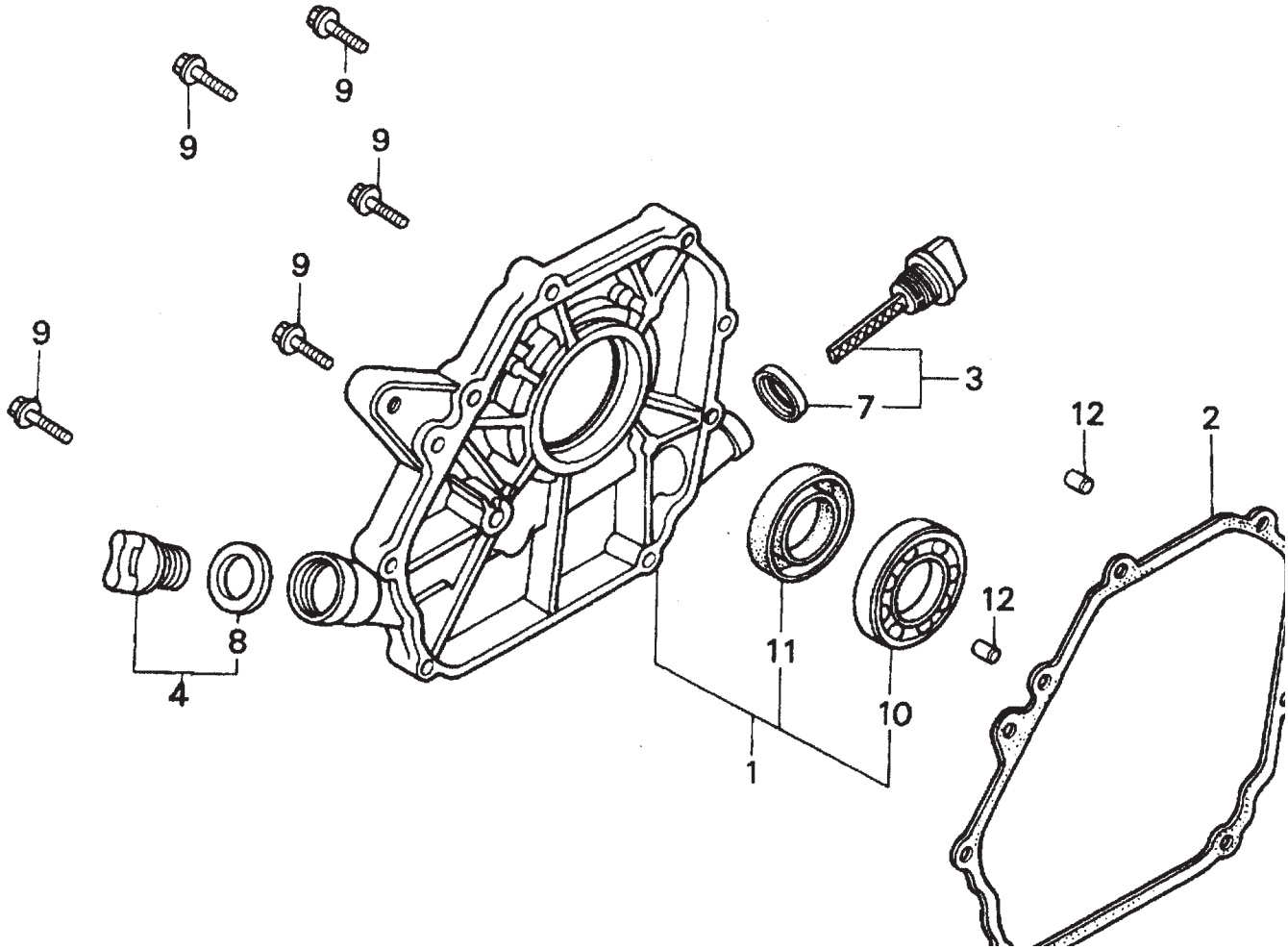

HONDA GX120UTQX2 ENGINE — CRANKCASE COVER ASSY.

CRANKCASE COVER ASSY.

<u>NO.</u>	<u>PART NO.</u>	<u>PART NAME</u>	<u>QTY.</u>	<u>REMARKS</u>
1	11300ZE0640	COVER ASSEMBLY, CRANKCASE (U- TYPE)	1	INCLUDES ITEMS W/%
2	11381ZH7800	GASKET, CASE COVER	1	
3	15600ZE1003	CAP ASSEMBLY, OIL FILLER	1	INCLUDES ITEMS W/#
4	15600ZG4003	CAP ASSEMBLY, OIL FILLER	1	INCLUDES ITEMS W/*
7#	15625ZE1003	GASKET, OIL FILLER CAP	1	
8*	15625ZE1003	GASKET, OIL FILLER CAP	1	
9	90015883000	BOLT, FLANGE 6X28	7	
10%	91001878003	BEARING, RADIAL BALL	1	
11%	91203ZE0003	OIL SEAL 22X41X6	1	
12	9430108140	PIN A, DOWEL 8X14	2	

HONDA GX120UTQX2 ENGINE — CRANKSHAFT ASSY.

CRANKSHAFT ASSY.

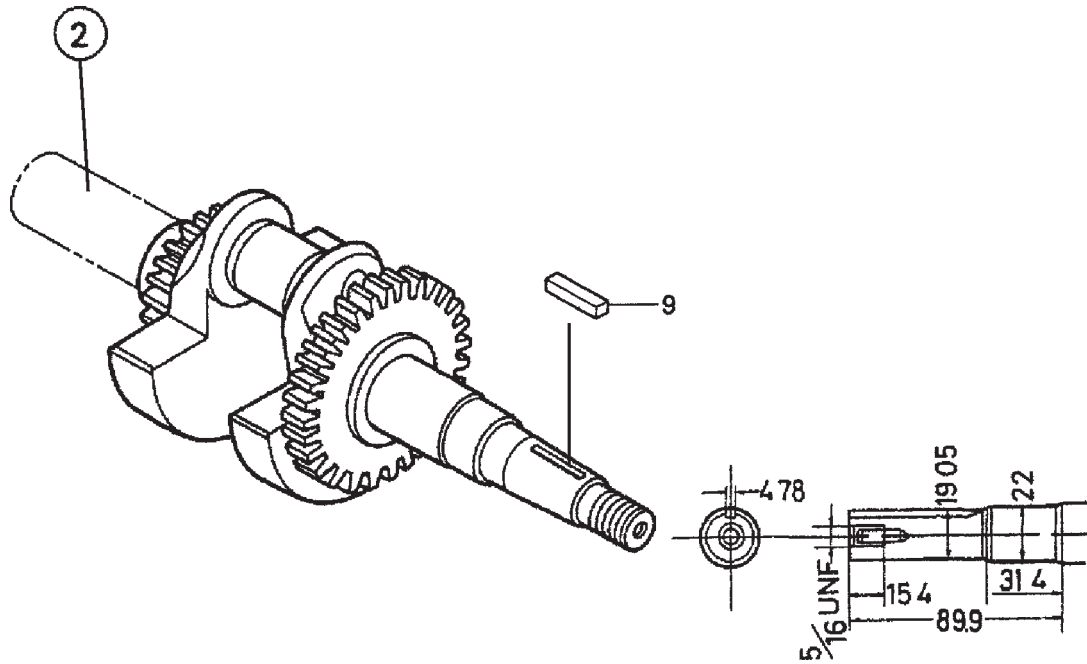

HONDA GX120UTQX2 ENGINE — CRANKSHAFT ASSY.

CRANKSHAFT ASSY.

<u>NO.</u>	<u>PART NO.</u>	<u>PART NAME</u>	<u>QTY.</u>	<u>REMARKS</u>
2	13310ZE0650	CRANKSHAFT, Q-TYPE	1	
9	90745ZE1600	KEY (4.78 X 4.78 X 38)	1	

HONDA GX120UTQX2 ENGINE — CYLINDER BARREL ASSY.

CYLINDER BARREL ASSY.

<u>NO.</u>	<u>PART NO.</u>	<u>PART NAME</u>	<u>QTY.</u>	<u>REMARKS</u>
2	12000ZH7415	CYLINDER ASSEMBLY, 811 (OIL ALERT)	1	INCLUDES ITEMS W/*
3	15510ZE1033	SWITCH ASSEMBLY, OIL LEVEL	1	
4	16510ZE1000	GOVERNOR ASSEMBLY	1	INCLUDES ITEMS W/#
5#	16511ZE1000	WEIGHT, GOVERNOR	2	
6#	16512ZE1000	HOLDER, GOVERNOR WEIGHT	1	
7#	16513ZE1000	PIN, GOVERNOR WEIGHT	2	
8	16531ZE1000	SLIDER, GOVERNOR	1	
9	16541ZE1000	SHAFT, GOVERNOR ARM	1	
10	90131ZE1000	BOLT, DRAIN PLUG	2	
11	90451ZE1000	WASHER, THRUST 6MM	1	
12	90601ZE1000	WASHER, DRAIN PLUG 10.2MM	2	
13	90602ZE1000	CLIP, GOVERNOR HOLDER	1	
14*	91001878003	BEARING, RADIAL BALL 62/22	1	
15*	91202ZE6003	OIL SEAL 22X35X6	1	
16	91353671003	O- RING 13.5X1.5 (ARAI)	1	
17	9405010000	NUT, FLANGE 10MM	1	
18	9410106800	WASHER, PLAIN 6MM	2	
19	9425108000	PIN, LOCK 8MM	1	
20	957010601200	BOLT, FLANGE 6X12	2	

HONDA GX120UTQX2 ENGINE — CYLINDER HEAD ASSY.

CYLINDER HEAD ASSY.

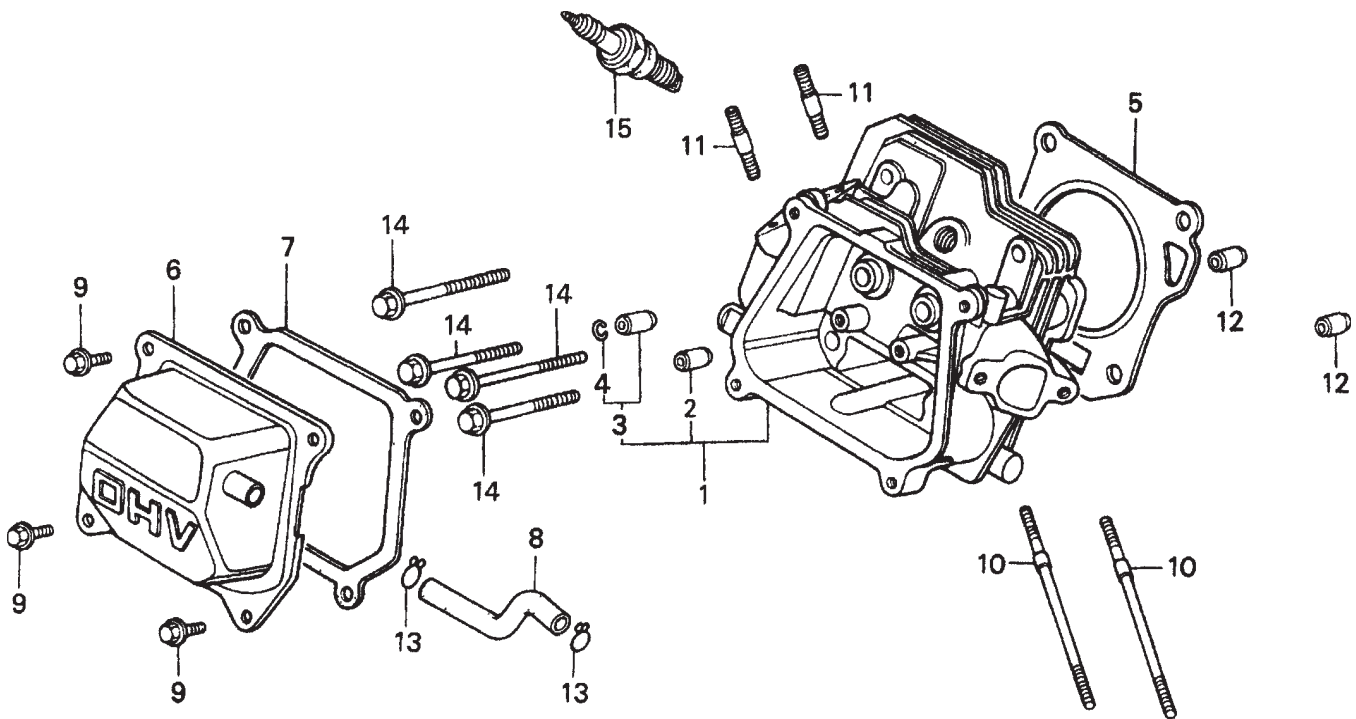

HONDA GX120UTQX2 ENGINE — CYLINDER HEAD ASSY.

CYLINDER HEAD ASSY.

<u>NO.</u>	<u>PART NO.</u>	<u>PART NAME</u>	<u>QTY.</u>	<u>REMARKS</u>
1	12210ZH7000	CYLINDER HEAD	1	INCLUDES ITEMS W/*
2*	12204ZE1306	GUIDE, VALVE (OS) OPTIONAL	1	
3*	12205ZE1315	GUIDE, EX. VALVE (OS) OPTIONAL	1	INCLUDES ITEMS W/#
4*#	12216ZE5300	CLIP, VALVE GUIDE	1	
5	12251ZH7800	GASKET, CYLINDER HEAD	1	
6	12310ZE1000	COVER, HEAD	1	
6	12310ZE1010	COVER, HEAD	1	
7	12391ZE1000	GASKET, CYLINDER HEAD COVER	1	
8	15721ZH8000	TUBE, BREATHER	1	
9	90013883000	BOLT, FLANGE 6X12 (CT200)	4	
10	90043ZE1020	BOLT, STUD 6X109	2	
11	90047ZE1000	BOLT, STUD 8X32	2	
12	9430110160	PIN, A, DOWEL 10X16	2	
14	957230805500	BOLT, FLANGE 8X55	4	
15	9807955855	SPARK PLUG W16EPR- U (DENSO), OPT.	1	
15	9807956846	SPARK PLUG BPR6ES, (NGK)	1	

HONDA GX120UTQX2 ENGINE — FAN COVER ASSY.

FAN COVER ASSY.

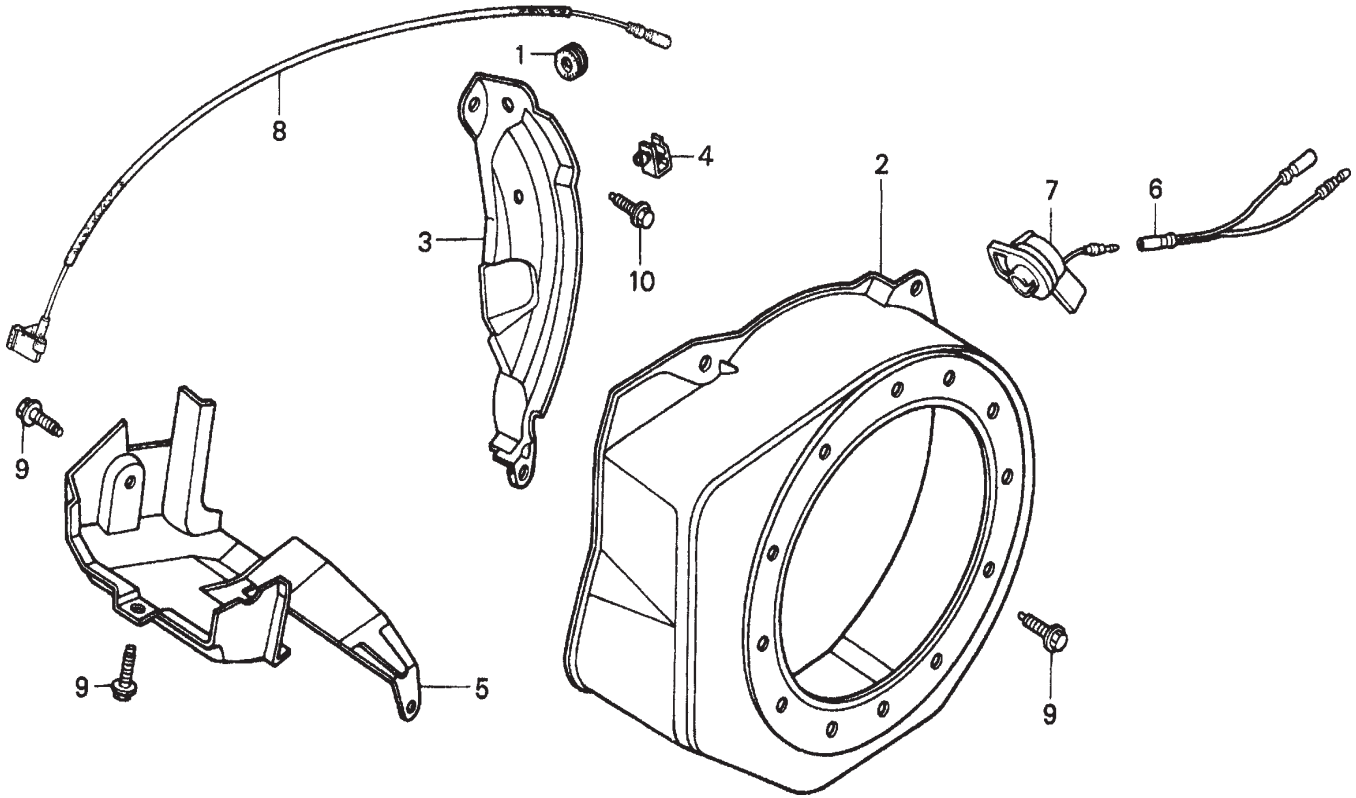

HONDA GX120UTQX2 ENGINE — FAN COVER ASSY.

FAN COVER ASSY.

<u>NO.</u>	<u>PART NO.</u>	<u>PART NAME</u>	<u>QTY.</u>	<u>REMARKS</u>
1	11347371300	GROMMET, ADJUSTING COVER	1	
2	19610ZE0000ZE	COVER, FAN *NH1* BLACK	1	
3	19612ZH7810	PLATE, SIDE (OIL ALERT)	1	
4	90601ZH7013	CLIP, HARNESS	1	
5	19630ZH7000	SHROUD	1	
6	32197ZH8003	SUB- HARNESS	1	
7	36100ZH7003	SWITCH ASSEMBLY, ENGINE STOP	1	
8	36101ZE1010	WIRE, STOP SWITCH 370MM	1	
9	90013883000	BOLT, FLANGE 6X12 (CT200)	6	
10	90022888010	BOLT, FLANGE 6X12 (CT200)	1	
11	34150ZH7003	ALERT UNIT, OIL	1	
13	957010600800	BOLT, FLANGE 6X8	1	

HONDA GX120UTQX2 ENGINE — FLYWHEEL ASSY.

FLYWHEEL ASSY.

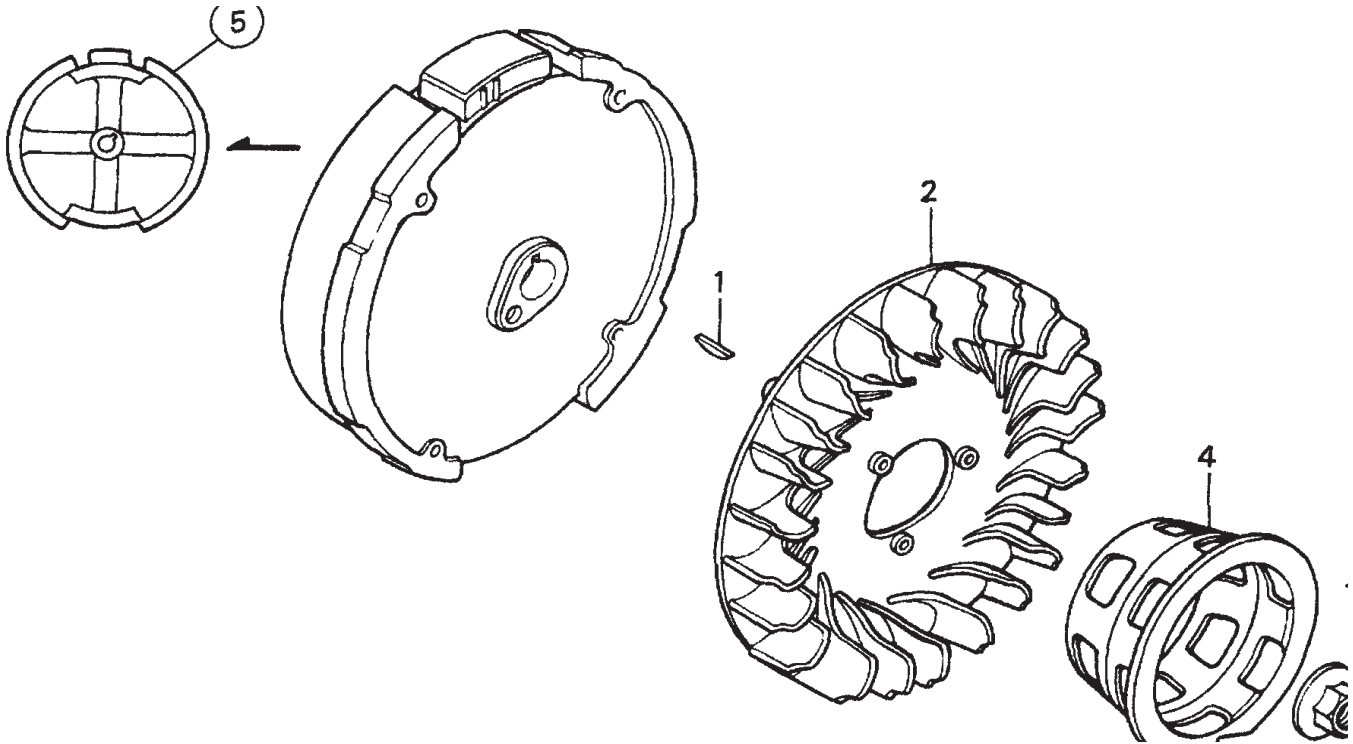

HONDA GX120UTQX2 ENGINE — FLYWHEEL ASSY.

FLYWHEEL ASSY.

<u>NO.</u>	<u>PART NO.</u>	<u>PART NAME</u>	<u>QTY.</u>	<u>REMARKS</u>
1	13331357000	KEY, SPECIAL WOODRUFF 25X18	1	
2	19511ZE0000	FAN, COOLING	1	
4	28451ZH8003	PULLEY, STARTER	1	
5	31100ZE0010	FLYWHEEL	1	
7	90201878003	NUT, SPECIAL 14MM	1	

HONDA GX120UTQX2 ENGINE — FUEL TANK ASSY.

FUEL TANK ASSY.

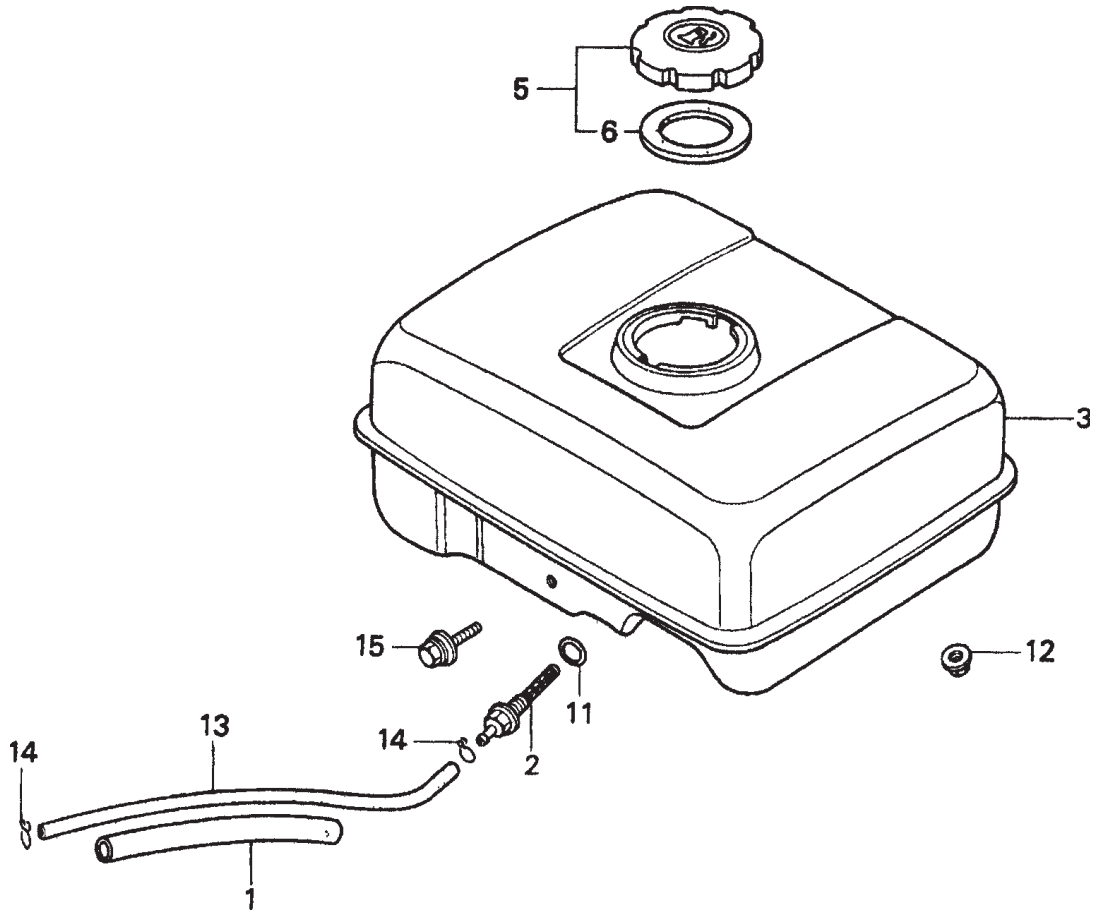

HONDA GX120UTQX2 ENGINE — FUEL TANK ASSY.

FUEL TANK ASSY.

<u>NO.</u>	<u>PART NO.</u>	<u>PART NAME</u>	<u>QTY.</u>	<u>REMARKS</u>
1	16854ZH8000	RUBBER, SUPPORTER 107MM	1	
2	16955ZE1000	JOINT, FUEL TANK	1	
3	17510ZE0020ZD	TANK, FUEL *NH1* (BLACK)	1	
5	17620ZH7023	CAP, FUEL FILLER	1	INCLUDES ITEMS W/*
6*	17631ZH7003	GASKET, FUEL FILLER CAP	1	
11	91353671003	O- RING 13.5X1.5 (ARAI)	1	
12	9405006000	NUT, FLANGE 6MM	2	
13	950014500360M	BULK HOSE, FUEL (4.5X3000) (4.5X140)	1	
14	9500202080	CLIP, TUBE (B8)	2	
15	90004ZH7003	BOLT, FLANGE 6X29	1	

HONDA GX120UTQX2 ENGINE — IGNITION COIL ASSY.

IGNITION COIL ASSY.

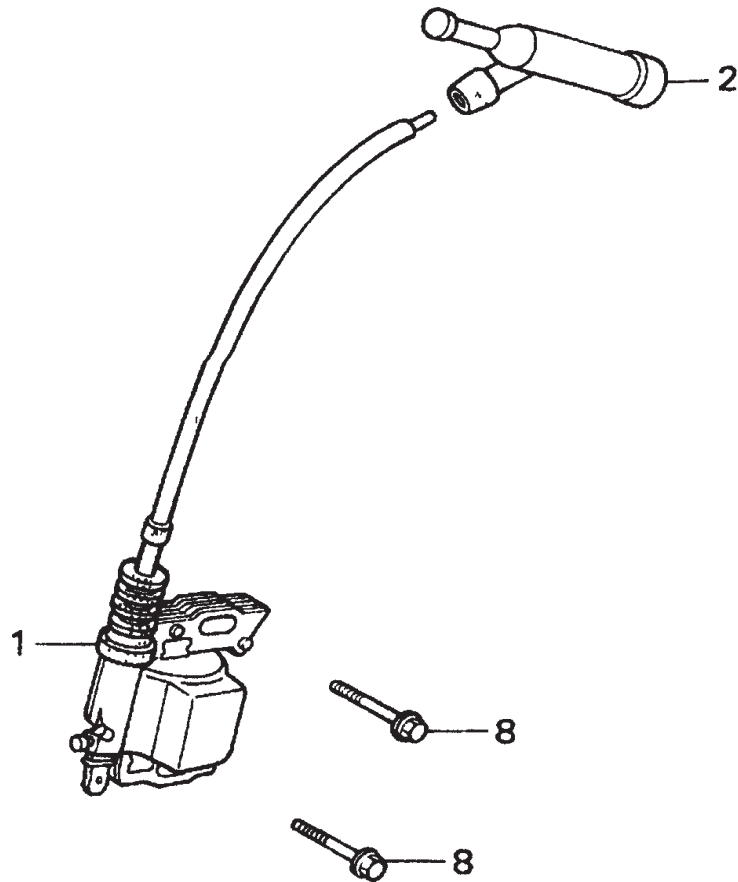

HONDA GX120UTQX2 ENGINE — IGNITION COIL ASSY.

IGNITION COIL ASSY.

<u>NO.</u>	<u>PART NO.</u>	<u>PART NAME</u>	<u>QTY.</u>	<u>REMARKS</u>
1	30500ZE1033	COIL ASSEMBLY, IGNITION	1	
2	30700ZE1013	CAP ASSEMBLY, NOISE SUPPRESSOR	1	
8	90121952000	BOLT, FLANGE 6X25	2	

HONDA GX120UTQX2 ENGINE — MUFFLER ASSY.

MUFFLER ASSY.

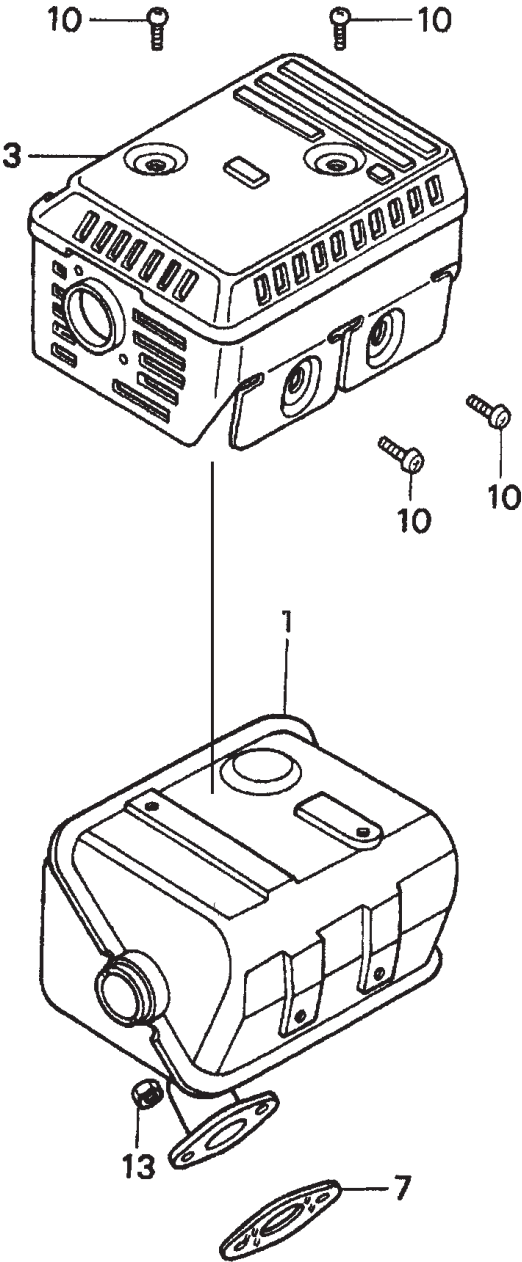

HONDA GX120UTQX2 ENGINE — MUFFLER ASSY.

MUFFLER ASSY.

<u>NO.</u>	<u>PART NO.</u>	<u>PART NAME</u>	<u>QTY.</u>	<u>REMARKS</u>
1	18310ZF1000	MUFFLER	1	
3	18320ZF1H01	PROTECTOR, MUFFLER	1	
7	18381ZH8800	GASKET, MUFFLER	1	
10	90050ZE1000	SCREW, TAPPING 5X8	4	
13	94001080000S	NUT, HEX. 8MM	2	

HONDA GX120UTQX2 ENGINE — PISTON ASSY.

PISTON ASSY.

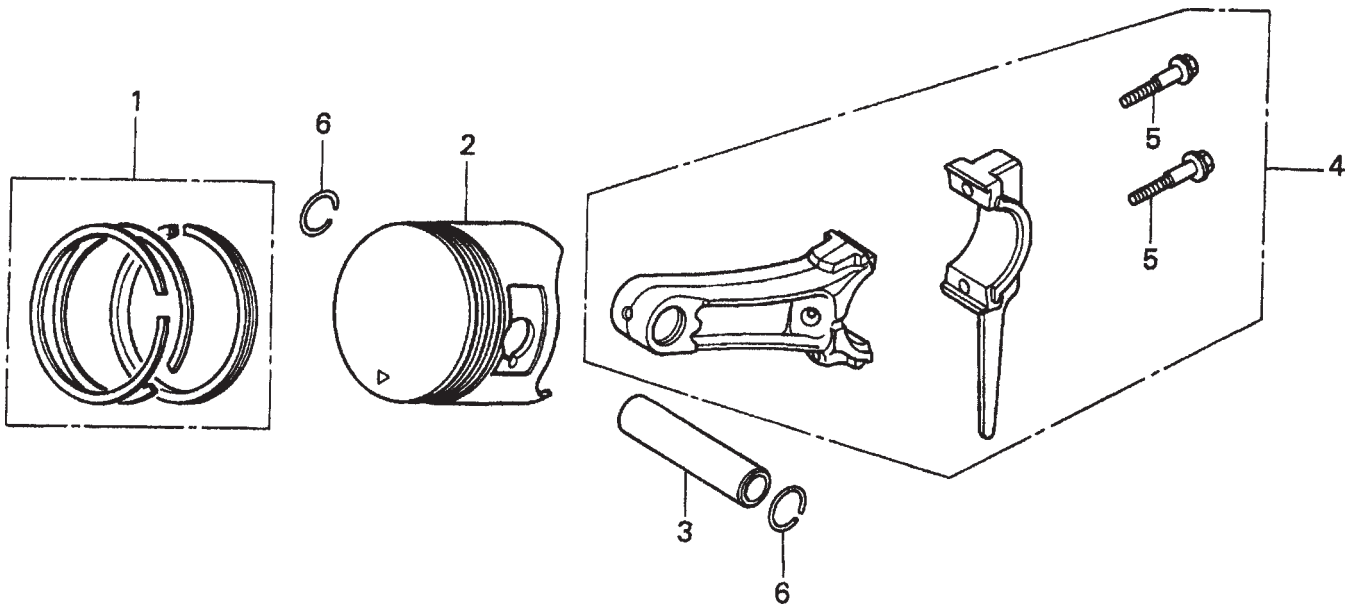

HONDA GX120UTQX2 ENGINE — PISTON ASSY.

PISTON ASSY.

<u>NO.</u>	<u>PART NO.</u>	<u>PART NAME</u>	<u>QTY.</u>	<u>REMARKS</u>
1	13010ZK7V01	RING SET, PISTON (STANDARD)	1	
1	13011ZK7V01	RING SET, PISTON (OS 0.25), OPTIONAL	1	
1	13012ZK7V01	RING SET, PISTON (OS 0.50), OPTIONAL	1	
1	13013ZK7V01	RING SET, PISTON (0.75), OPTIONAL	1	
2	13101ZH7000	PISTON, STANDARD	1	
2	13102ZH7000	PISTON, OS 0.25 (OPTIONAL)	1	
2	13103ZH7000	PISTON, OS 0.50 (OPTIONAL)	1	
2	13104ZH7000	PISTON, 0.75 (OPTIONAL)	1	
3	13111ZE0000	PIN, PISTON	1	
4	132A0ZE0000	ROD ASSY., CONNECTING (UNDERSIZE) OPTIONAL	1	INCLUDES ITEMS W/*
4	13200ZE0000	ROD ASSEMBLY, CONNECTING	1	INCLUDES ITEMS W/*
5*	90001ZE1000	BOLT, CONNECTING ROD	2	
6	90551ZE0000	CLIP, PISTON PIN 13MM	2	

HONDA GX120UTQX2 ENGINE — RECOILSTARTER ASSY.

RECOIL STARTER ASSY.

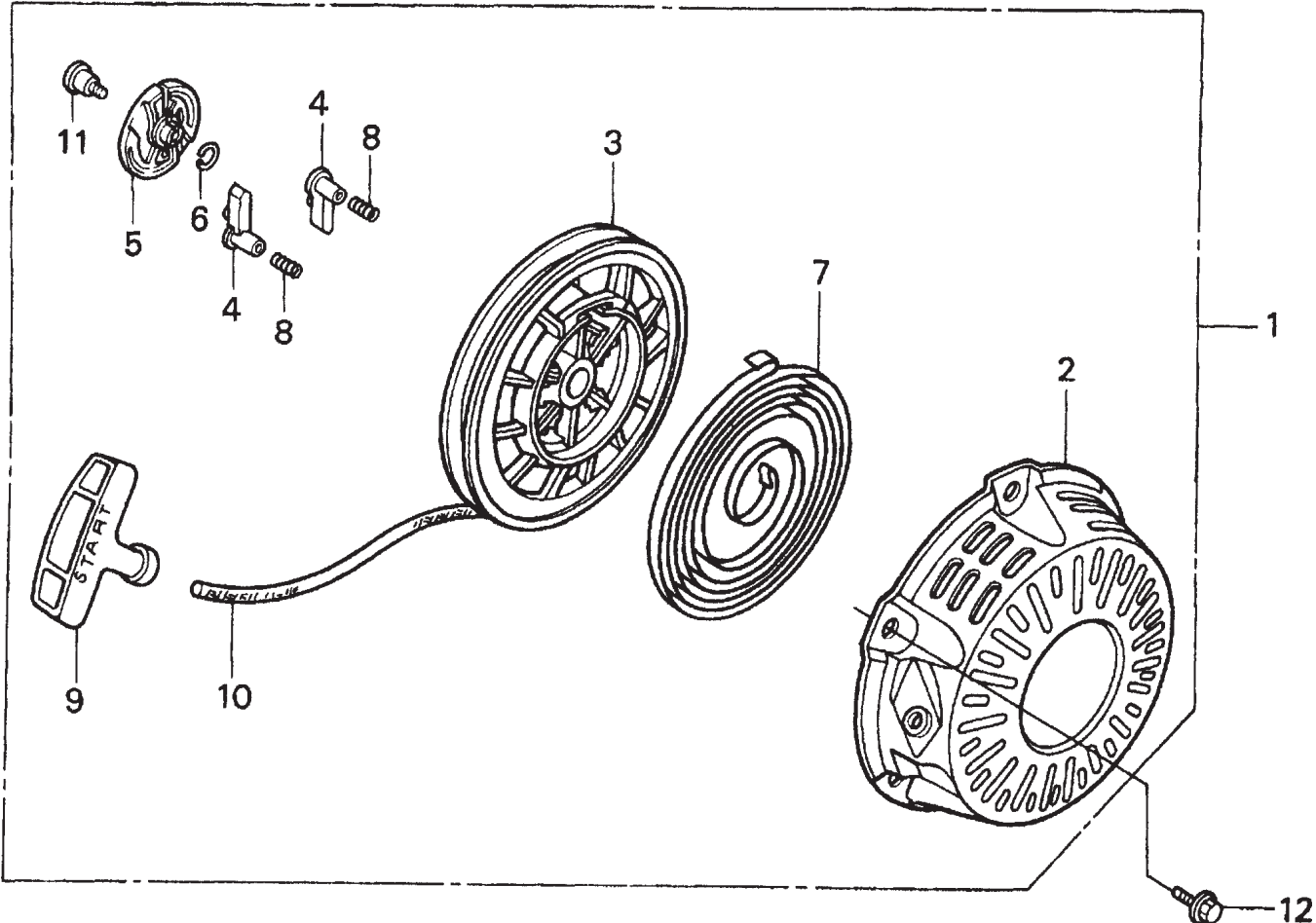

HONDA GX120UTQX2 ENGINE — RECOILSTARTER ASSY.

RECOIL STARTER ASSY.

<u>NO.</u>	<u>PART NO.</u>	<u>PART NAME</u>	<u>QTY.</u>	<u>REMARKS</u>
1	28400ZH8013ZB	STARTER ASSY., RECOIL *NH1* (BLACK)	1	INCLUDES ITEMS W/*
2*	28410ZH8003ZB	CASE, RECOIL STARTER	1	
3*	28420ZH8013	REEL, RECOIL STARTER	1	
4*	28422ZH8013	RATCHET, STARTER	2	
5 *	28433ZH8003	GUIDE, RATCHET	1	
6*	28441ZH8003	SPRING, FRICTION	1	
7*	28442ZH8003	SPRING, RECOIL STARTER	1	
8*	28443ZH8003	SPRING, RETURN	2	
9*	28461ZH8003	KNOB, RECOIL STARTER	1	
10*	28462ZH8003	ROPE, RECOIL STARTER	1	
11*	90003ZH8003	SCREW, SETTING	1	
12	90008ZE2003	BOLT, FLANGE 6X10	3	

GASKET KIT ASSY.

NO ART WORK

HONDA GX120UTQX2 ENGINE — GASKET KIT ASSY.

GASKET KIT ASSY.

<u>NO.</u>	<u>PART NO.</u>	<u>PART NAME</u>	<u>QTY.</u>	<u>REMARKS</u>
1	06111ZH7405	GASKET KIT	1	INCLUDES ITEMS W/*
2*	11381ZH7800	GASKET, CASE COVER	1	
3*	12251ZH7800	GASKET, CYLINDER HEAD	1	
4*	12391ZE1000	GASKET, CYLINDER HEAD COVER	1	
5*	16212ZH7800	GASKET, INSULATOR	1	
6*	16221ZH8801	GASKET, CARBURETOR	1	
7*	18381ZH8800	GASKET, MUFFLER	1	

HONDA GX120UTQX2 ENGINE — LABELS ASSY.

LABELS ASSY.

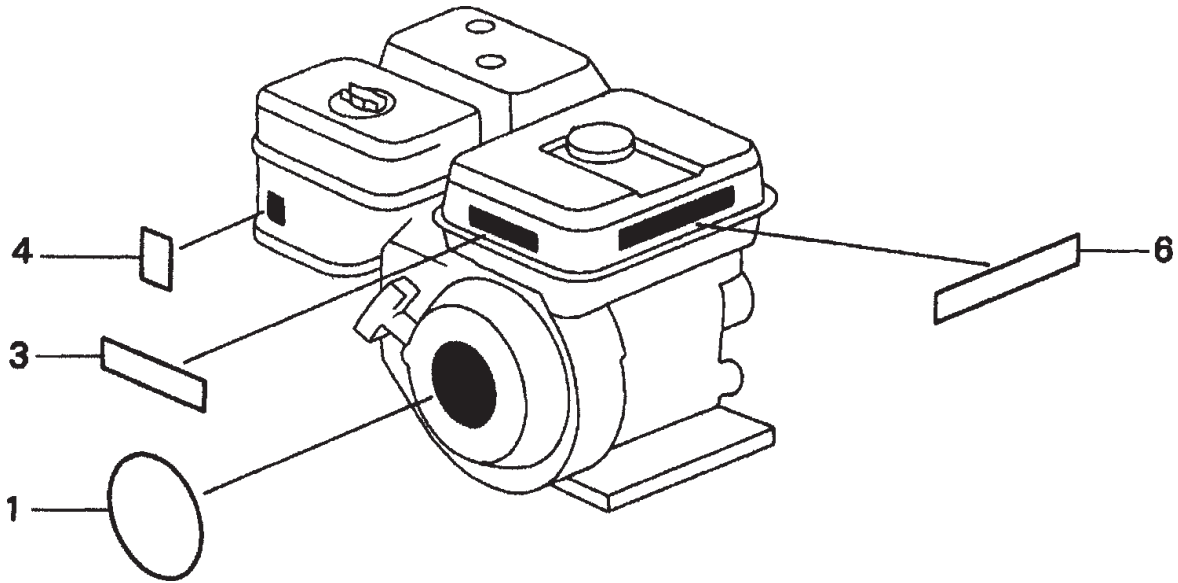

HONDA GX120UTQX2 ENGINE — LABELS ASSY.

LABELS ASSY.

<u>NO.</u>	<u>PART NO.</u>	<u>PART NAME</u>	<u>QTY.</u>	<u>REMARKS</u>
1	87521ZH7020	EMBLEM	1	
3	87522ZH9000	LABEL, CAUTION	1	
4	87528ZE1810	MARK, CHOKE	1	
6	87532ZH8810	MARK, OIL ALERT (E)	1	

TERMS AND CONDITIONS OF SALE — PARTS

PAYMENT TERMS

Terms of payment for parts are net 30 days.

FREIGHT POLICY

All parts orders will be shipped collect or prepaid with the charges added to the invoice. All shipments are F.O.B. point of origin. Multiquip's responsibility ceases when a signed manifest has been obtained from the carrier, and any claim for shortage or damage must be settled between the consignee and the carrier.

MINIMUM ORDER

The minimum charge for orders from Multiquip is \$15.00 net. Customers will be asked for instructions regarding handling of orders not meeting this requirement.

RETURNED GOODS POLICY

Return shipments will be accepted and credit will be allowed, subject to the following provisions:

1. A Returned Material Authorization must be approved by Multiquip prior to shipment.
2. To obtain a Return Material Authorization, a list must be provided to Multiquip Parts Sales that defines item numbers, quantities, and descriptions of the items to be returned.
 - a. The parts numbers and descriptions must match the current parts price list.
 - b. The list must be typed or computer generated.
 - c. The list must state the reason(s) for the return.
 - d. The list must reference the sales order(s) or invoice(s) under which the items were originally purchased.
 - e. The list must include the name and phone number of the person requesting the RMA.
3. A copy of the Return Material Authorization must accompany the return shipment.
4. Freight is at the sender's expense. All parts must be returned freight prepaid to Multiquip's designated receiving point.

5. Parts must be in new and resalable condition, in the original Multiquip package (if any), and with Multiquip part numbers clearly marked.
6. The following items are not returnable:
 - a. Obsolete parts. (If an item is in the price book and shows as being replaced by another item, it is obsolete.)
 - b. Any parts with a limited shelf life (such as gaskets, seals, "O" rings, and other rubber parts) that were purchased more than six months prior to the return date.
 - c. Any line item with an extended dealer net price of less than \$5.00.
 - d. Special order items.
 - e. Electrical components.
 - f. Paint, chemicals, and lubricants.
 - g. Decals and paper products.
 - h. Items purchased in kits.
7. The sender will be notified of any material received that is not acceptable.
8. Such material will be held for five working days from notification, pending instructions. If a reply is not received within five days, the material will be returned to the sender at his expense.
9. Credit on returned parts will be issued at dealer net price at time of the original purchase, less a 15% restocking charge.
10. In cases where an item is accepted, for which the original purchase document can not be determined, the price will be based on the list price that was effective twelve months prior to the RMA date.
11. Credit issued will be applied to future purchases only.

PRICING AND REBATES

Prices are subject to change without prior notice. Price changes are effective on a specific date and all orders received on or after that date will be billed at the revised price. Rebates for price declines and added charges for price increases will not be made for stock on hand at the time of any price change.

Multiquip reserves the right to quote and sell direct to Government agencies, and to Original Equipment Manufacturer accounts who use our products as integral parts of their own products.

SPECIAL EXPEDITING SERVICE

A \$35.00 surcharge will be added to the invoice for special handling including bus shipments, insured parcel post or in cases where Multiquip must personally deliver the parts to the carrier.

LIMITATIONS OF SELLER'S LIABILITY

Multiquip shall not be liable hereunder for damages in excess of the purchase price of the item with respect to which damages are claimed, and in no event shall Multiquip be liable for loss of profit or good will or for any other special, consequential or incidental damages.

LIMITATION OF WARRANTIES

No warranties, express or implied, are made in connection with the sale of parts or trade accessories nor as to any engine not manufactured by Multiquip. Such warranties made in connection with the sale of new, complete units are made exclusively by a statement of warranty packaged with such units, and Multiquip neither assumes nor authorizes any person to assume for it any other obligation or liability whatever in connection with the sale of its products. Apart from such written statement of warranty, there are no warranties, express, implied or statutory, which extend beyond the description of the products on the face hereof.

Effective: February 22, 2006

PARTS MANUAL

HERE'S HOW TO GET HELP

PLEASE HAVE THE MODEL AND SERIAL
NUMBER *ON-HAND* WHEN CALLING

UNITED STATES

Multiquip Corporate Office

18910 Wilmington Ave. Tel. (800) 421-1244
Carson, CA 90746 Fax (800) 537-3927
Contact: mq@multiquip.com

Mayco Parts

800-306-2926 Fax: 800-672-7877
310-537-3700 Fax: 310-637-3284

Service Department

800-421-1244 Fax: 310-537-4259
310-537-3700

MQ Parts Department

800-427-1244 Fax: 800-672-7877
310-537-3700 Fax: 310-637-3284

Warranty Department

800-421-1244, Ext. 279 Fax: 310-537-1173
310-537-3700, Ext. 279

Technical Assistance

800-478-1244 Fax: 310-631-5032

MEXICO

MQ Cipsa

Carr. Fed. Mexico-Puebla KM 126.5 Tel. (52) 222-225-9900
Momoxpan, Cholula, Puebla 72760 Mexico Fax (52) 222-285-0420
Contact: pmastretta@cipsa.com.mx

CANADA

Multiquip

4110 Industriel Boul. Tel. (450) 625-2244
Laval, Quebec, Canada H7L 6V3 Fax (450) 625-8664
Contact: jmartin@multiquip.com

UNITED KINGDOM

Multiquip (UK) Limited Head Office

Hanover Mill, Fitzroy Street, Tel. 0161 339 2223
Ashton-under-Lyne, Fax 0161 339 3226
Lancashire OL7 0TL
Contact: sales@multiquip.co.uk

BRAZIL

Multiquip

Av. Evandro Lins e Silva, 840 - grupo 505 Tel. 011-55-21-3433-9055
Barra de Tijuca - Rio de Janeiro Fax 011-55-21-3433-9055
Contact: cnavarro@multiquip.com.br, srentes@multiquip.com.br

© COPYRIGHT 2007, MULTQUIP INC.

Multiquip Inc, the MQ logo and the Whiteman logo are registered trademarks of Multiquip Inc. and may not be used, reproduced, or altered without written permission. All other trademarks are the property of their respective owners and used with permission.

This manual MUST accompany the equipment at all times. This manual is considered a permanent part of the equipment and should remain with the unit if resold.

The information and specifications included in this publication were in effect at the time of approval for printing. Illustrations, descriptions, references and technical data contained in this manual are for guidance only and may not be considered as binding. Multiquip Inc. reserves the right to discontinue or change specifications, design or the information published in this publication at any time without notice and without incurring any obligations.

Your Local Dealer is:



MULTIQUIP INC.

18910 WILMINGTON AVE.
CARSON, CALIFORNIA 90746
800-421-1244 • 310-537-3700
FAX: 310-537-3927
E-mail: mq@multiquip.com
Internet: multiquip.com