

PARTS AND OPERATION MANUAL



PLASTER/MORTAR MIXERS EM-120SM (Steel-Mechanical)

EFFECTIVE S/N 92402494

© COPYRIGHT 2001, MULTIQUIP INC.

Revision #4 (05/24/05)



MULTIQUIP INC.

18910 WILMINGTON AVE.
CARSON, CALIFORNIA 90746
310-537-3700
800-421-1244
FAX: 310-537-3927

E-mail: mq@multiquip.com • **www:** multiquip.com

Atlanta • Boise • Dallas • Houston • Newark
Montreal, Canada • Manchester, UK
Rio De Janeiro, Brazil • Guadalajara, Mexico

PARTS DEPARTMENT:

800-427-1244
FAX: 800-672-7877

SERVICE DEPARTMENT/TECHNICAL ASSISTANCE:

800-478-1244
FAX: 310-631-5032



WARNING



CALIFORNIA — Proposition 65 Warning

Engine exhaust and some of its constituents, and some dust created by power sanding, sawing, grinding, drilling and other construction activities contains chemicals known to the State of California to cause cancer, birth defects and other reproductive harm. Some examples of these chemicals are:

- Lead from lead-based paints.
- Crystalline silica from bricks.
- Cement and other masonry products.
- Arsenic and chromium from chemically treated lumber.

Your risk from these exposures varies, depending on how often you do this type of work. To reduce your exposure to these chemicals: **ALWAYS** work in a well ventilated area, and work with approved safety equipment, such as dust masks that are specially designed to filter out microscopic particles.

HERE'S HOW TO GET HELP

*PLEASE HAVE THE MODEL AND SERIAL NUMBER
ON-HAND WHEN CALLING*

PARTS DEPARTMENT

800-427-1244 or 310-537-3700

FAX: 800-672-7877 or 310-637-3284

SERVICE DEPARTMENT/TECHNICAL ASSISTANCE

800-478-1244 or 310-537-3700

FAX: 310- 537-4259

WARRANTY DEPARTMENT

888-661-4279, or 310-661-4279

FAX: 310- 537-1173

MAIN

800-421-1244 or 310-537-3700

FAX: 310-537-3927

TABLE OF CONTENTS

Here's How To Get Help 3
Table Of Contents 4
Parts Ordering Procedures 5
Operation and Safety Decals 6
Rules For Safe Operation 7-8
Specifications 9
General Information 10

Essick — Plaster/ Mortar Mixer

Controls 11
Electric Motor 12
Towing 13
Paddle Blade Adjustment 14
Initial Start-Up 15-16
Maintenance 17-19
Troubleshooting (Engine) 20
Troubleshooting (Engine/Mixer) 21
Explanation Of Codes In Remarks Column 22
Suggested Spare Parts 23
Mixing Drum Assembly 24-25
Paddle Shaft Assembly 26-27
Frame Assembly 28-29
Cab Assembly 30-31

Engines

Wisconsin Engine Assembly 32-33
Honda Engine Assembly 34-35

Motor

Electric Motor Assembly 36-37

Transmissions

Transmission Assembly 38-39
Terms and Conditions Of Sale — Parts 40

NOTE

Specification and part number are subject to change without notice.

- Dealer account number
- Dealer name and address
- Shipping address (if different than billing address)
- Return fax number
- Applicable model number
- Quantity, part number and description of each part
- Specify preferred method of shipment:
 - UPS Ground
 - UPS Second Day or Third Day*
 - UPS Next Day*
 - Federal Express Priority One (please provide us with your Federal Express account number)*
 - Airborne Express*
 - Truck or parcel post

**Normally shipped the same day the order is received, if prior to 2PM west coast time.*

Earn Extra Discounts when you order by FAX!

All parts orders which include complete part numbers and are received by fax qualify for the following extra discounts:

<u>Number of line items ordered</u>	<u>Additional Discount</u>
1-9 items	3%
10+ items**	5%

Get special freight allowances when you order 10 or more line items via FAX!**

- UPS Ground Service at no charge for freight
- PS Third Day Service at one-half of actual freight cost

No other allowances on freight shipped by any other carrier.

**Common nuts, bolts and washers (all items under \$1.00 list price) do not count towards the 10+ line items.

DISCOUNTS ARE SUBJECT TO CHANGE

Fax order discount and UPS special programs revised June 1, 1995

**Extra Fax Discount
for Domestic USA
Dealers Only**

**Up to 5%
extra savings!**

**UPS
Special**
For faxed orders only

**Now! Direct TOLL-FREE access
to our Parts Department!**

Toll-free nationwide:

800-421-1244

Toll-free FAX:

800/6-PARTS-7 • 800-672-7877

The safety instruction decals shown must be on all Essick Mixers

CAUTION!
SHUT OFF ENGINE BEFORE
PUTTING HANDS IN MIXING DRUM

P/N EM948423

ESSICK SAFETY INSTRUCTIONS

1. Read owners manuals before operating.
2. Keep unauthorized and untrained people away from machine during operation.
3. Make sure all safety devices are in place before this machine is started.
4. Make sure engine is turned off and spark plug wire is disconnected before cleaning the machine.
5. Keep hands and fingers away from moving objects.
6. Do not operate machine in an enclosed area. Proper ventilation is required.
7. Never leave machine unattended when operating.
8. Always stop engine and allow engine to cool before adding fuel or oil.

A MULTQUIP COMPANY — CARSON, CALIFORNIA

P/N 948501

NAMEPLATE

CONTACT MULTQUIP
SERVICE DEPT.

RULES FOR SAFE OPERATION

CAUTION:



Failure to follow instructions in this manual may lead to serious injury or even death! This equipment is to be operated by trained and qualified personnel only! This equipment is for industrial use only.

The following safety guidelines should always be used when operating the EM-120SM mixers:

GENERAL SAFETY

- **DO NOT** operate or service this equipment before reading this entire manual.



- This equipment should not be operated by persons under 18 years of age.

- **NEVER** operate this equipment without proper protective clothing, shatterproof glasses, steel-toed boots and other protective devices required by the job.



- **NEVER** operate this equipment when not feeling well due to fatigue, illness or taking medicine.



- **NEVER** operate this equipment under the influence of drugs or alcohol.



- **NEVER** use accessories or attachments, which are not recommended by Multiquip for this equipment. Damage to the equipment and/or injury to user may result.

- Manufacture does not assume responsibility for any accident due to equipment modifications.

- Whenever necessary, replace nameplate, operation and safety decals when they become difficult read.

- Always check the machine for loosened threads or bolts before starting.

- **NEVER** touch the hot exhaust manifold, muffler or cylinder. Allow these parts to cool before servicing engine or mixer.



- **High Temperatures** – Allow the engine to cool before adding fuel or performing service and maintenance functions. Contact with *hot* components can cause serious burns.

- The engine section of this mixer requires an adequate free flow of cooling air. Never operate the mixer in any enclosed or narrow area where free flow of the air is restricted. If the air flow is restricted it will cause serious damage to the mixer or engine and may cause injury to people. Remember the mixer's engine gives off **DEADLY** carbon monoxide gas.

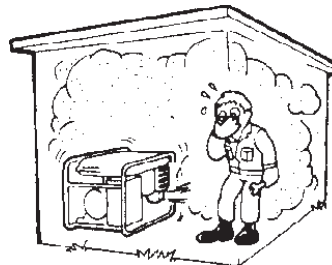

- Always refuel in a well-ventilated area, away from sparks and open flames.



- Always use extreme caution when working with **flammable** liquids. When refueling, **stop** the engine and allow it to cool. **DO NOT** smoke around or near the machine. Fire or explosion could result from fuel vapors, or if fuel is spilled on a hot engine.

- **NEVER** operate the mixer in an explosive atmosphere or near combustible materials. An explosion or fire could result causing severe *bodily harm or even death*.

CAUTION:



Failure to follow instructions in this manual may lead to serious injury or even death! This equipment is to be operated by trained and qualified personnel only! This equipment is for industrial use only.

The following safety guidelines should always be used when operating the EM-120SM Mixer:

GENERAL SAFETY

- Stop the engine when leaving the mixer unattended.
- Block the unit when leaving or when using on a slope.
- Maintain this equipment in a safe operating condition at all times.
- Always stop the engine before servicing, adding fuel and oil.
- **NEVER** Run engine without air filter. Severe engine may occur.
- Always service air cleaner frequently to prevent carburetor malfunction.
- Always be sure the operator is familiar with proper safety precautions and operations techniques before using mixer.
- Always store equipment properly when it is not being used. Equipment should be stored in a clean, dry location out of the reach of children.
- **NEVER** use accessories or attachments, which are not recommended by Multiquip for this equipment. Damage to the equipment and/or injury to user may result.
- **NEVER** Run engine without air cleaner. Severe engine damage may occur.
- Always read, understand, and follow procedures in Operator's Manual before attempting to operate equipment.
- Always be sure the operator is familiar with proper safety precautions and operations techniques before using pump.
- Always store equipment properly when it is not being used. Equipment should be stored in a clean, dry location out of the reach of children.

CAUTION:



■ **DO NOT** operate this equipment unless all guards and safety devices are attached and in place.

- Caution must be exercised while servicing this equipment. Rotating and moving parts can cause injury if contacted.
- When towing, an adequate safety chain must be fastened to the frame, refer to page 14.
- Keep all inexperienced and unauthorized people away from the equipment at all times.
- Unauthorized equipment modifications will void all warranties.
- Check all fasteners periodically for tightness. Also check towing tongue bolt, lock nut and wheel lug nuts for wear.
- Stop the engine and disconnect the spark plug before allowing anybody's hands in the mixing drum.
- Never pour or spray water over the engine or electric motor.
- Always stand clear of dump handle when mixer is in operation. Any binding of material between the mixer blades and drum will cause drum and handle to quickly move in the discharge position.
- Depending on type of mixer, test the **ON/OFF** switch for either the gasoline engine or electric motor before operating. The purpose of these switches is to shut down the engine or motor of the mixer.

Emergencies

- Always know the location of the nearest **fire extinguisher** and **first aid kit**. Know the location of the nearest telephone. Also know the phone numbers of the nearest **ambulance, doctor** and **fire department**. This information will be invaluable in the case of an emergency.

Maintenance Safety

- **NEVER** lubricate components or attempt service on a running machine.
- Always allow the machine a proper amount of time to cool before servicing.
- Keep the machinery in proper running condition.
- Fix damage to the machine immediately and always replace broken parts.
- Dispose of hazardous waste properly. Examples of potentially hazardous waste are used motor oil, fuel and fuel filters.
- **DO NOT** use food or plastic containers to dispose of hazardous waste. **Emergencies**
- Always know the location of the nearest **fire extinguisher** and **first aid kit**. Know the location of the nearest telephone. Also know the phone numbers of the nearest **ambulance, doctor** and **fire department**. This information will be invaluable in the case of an emergency.

Table 1. EM120SM Mixer Specifications

Capacity	12 cu. ft (340 liters)
Bag Capacity	3.5 to 4 bags
Weight	1,090 lbs (494 kg.)
Length w/Tow Bar x W x H	82 x 51 x 60 in. (208 x 130 x 152 cm)
Height W/Dump Handle	75 in. (191 cm)
Discharge Height	75 in. (191 cm)
Drive	Mechanical
Dump Action	Manual
Power Sources	5 HP Single-Phase 230/460 Electric Motor 5 HP Three-Phase 230/460 Electric Motor 11 HP Honda Engine 9.2 HP Wisc. AENLD-3 Engine

NOTE

In accordance with our established policy of constant improvement, we reserve the right to amend these specifications at any time without notice.

GENERAL

The Essick EM-120SM Series plaster and mortar mixers are shipped completely assembled and have been factory tested.

The drum batch capacity of these mixers is between 3.5 and 4.0 bags. With proper care, they will give continuous service year-after-year.

These mixers can be powered by either gasoline or electric motors. The power from the engine is transmitted via the clutch/reduction assembly directly to the paddle shaft. Therefore providing high mixer torque and eliminating V-belts .

BEFORE STARTING

Before starting the engine, read the engine owners manual and thoroughly understand the safety information.

Check the items listed below:

OIL LEVELS

Be sure to check the oil levels in the engine and engine reduction unit before starting the unit.

HARDWARE

Check all hardware on the mixer before starting. Periodically inspect all hardware. Loose hardware can contribute to early component failure and poor performance. Use the torque chart below as a general guideline and keep all hardware tight:

HARDWARE DIA

TORQUE (LB./FT.)

5/16" - 18	24
3/8" - 24	37
1/2" - 13	39
1/2" - 13 (Grade 8)	90

GASOLINE ENGINE CARE

For care and operation of the gasoline engine, refer to the engine manufacturer's operating instructions furnished with the engine. We recommend draining and refilling the engine crankcase at least every thirty hours of operation. Check the engine oil level daily.

GASOLINE MIXER OFF/ON SWITCH

This feature is on gasoline engine mixers only. Located on the side of the engine cover. The purpose of this switch is to start and stop the mixer in normal operation.

ELECTRIC MOTOR MIXER OFF/ON SWITCH

This feature is on electric motor mixers only. This switch is located on top of the motor. Lift the engine cover to gain access to this switch. The purpose of this switch is to start and stop the mixer in normal operation. Never use the electric motor in an explosive environment.

ENGINE THROTTLE AND CHOKE CONTROLS

Please refer to the engine owners manual for specific instructions.

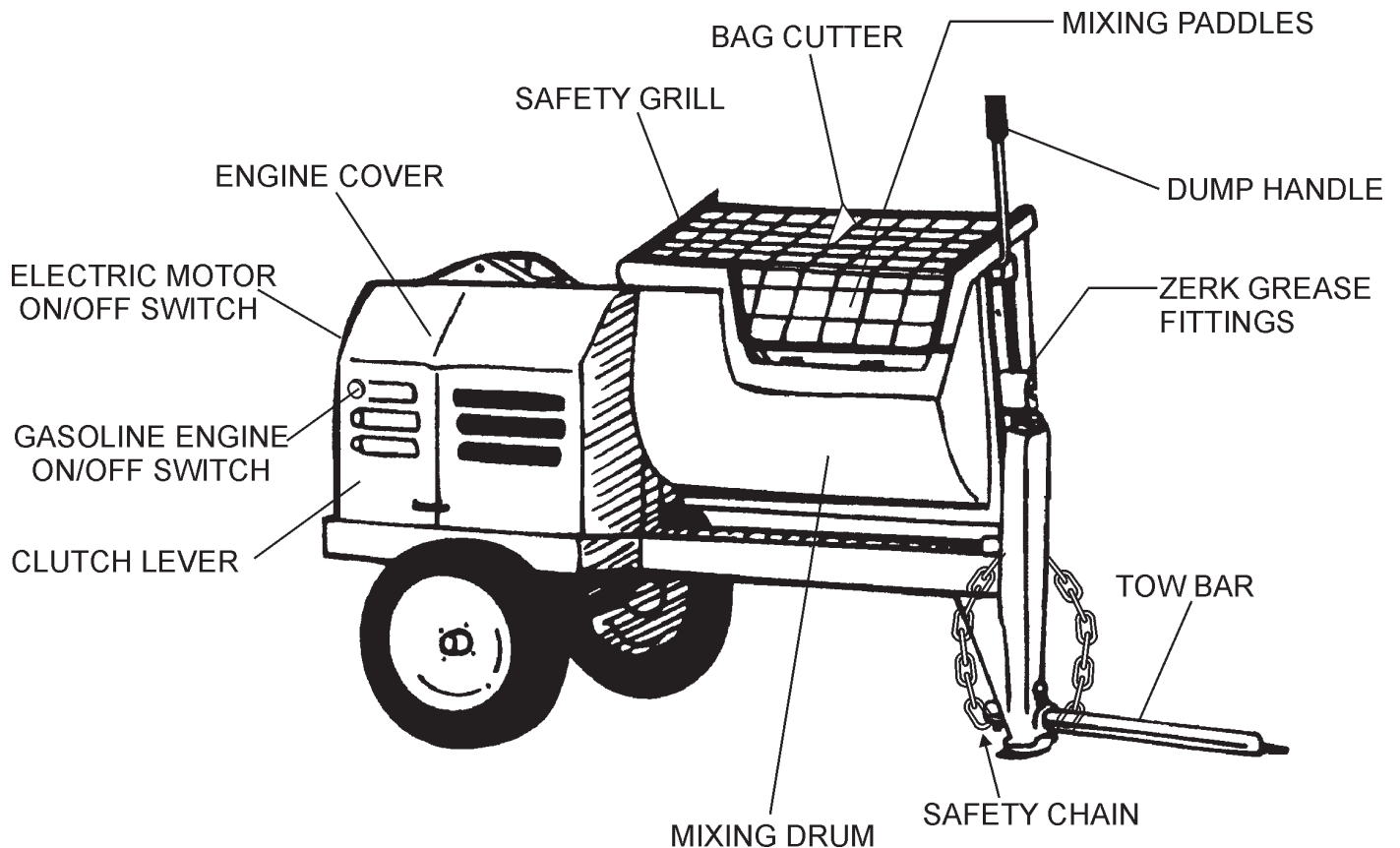

Figure 1. Mixer

Safety Grill — Provided for operator safety. This safety grill is designed to keep hands and solid objects out of the mixing drum when in use. This grill should be closed at all times when mixer is in use. **DO NOT** remove the grill or grill opening bar. Keep the grill clean by washing it down daily.

Bag Cutter— This feature allows compound mixing bags to be opened easily, therefore allowing the contents of the bag to fall directly into the mixing drum.

Mixing Paddles — Used in the mixing of material. This unit uses four different types of paddles to provide a fast uniform mix.

Dump Handle — Pull this handle downward to dump the contents of the drum. Push the handle upward to return the drum to its vertical position.

Zerk Fitting — There is, on each end of the mixing drum a zerk grease fitting. These fittings lubricate the dumping mechanism. Lubricate both fittings at least twice a week.

Mixing Drum — Made of **steel**. Mixing materials such as concrete, mortar, plaster are to be placed into this drum for mixing. Always clean the drum after each use.

Tow Bar — When towing is required, connect tow bar to a vehicle Reference page 14.

Engine Cover — Lift this cover to gain access to the engine compartment.

ON/OFF Switch (gasoline) — This switch is provided on *mixers with gasoline* engines only and is located on the side of the engine cover. When activated it will shut down the engine.

ON/OFF Switch (electric) — This switch is provided on mixers with electric motors. To gain access to this switch, lift the engine cover. When activated it will shut down the electric motor.

Clutch Lever — Push the clutch lever forward, toward the tow tongue end of the mixer to engage clutch. Once clutch is engaged paddle shaft will rotate. To disengage clutch pull the clutch backwards towards the engine.

ELECTRIC MOTOR

For lubrication care and operation of the electric motor, refer to your electric motor instruction booklet furnished with the motor.

Protect the electric motor from dust as much as possible and keep ventilating openings clean.

CAUTION:



- **DO NOT** spray water at any time on the *electric motor*.
- **DO NOT** operate electric motor in a explosive environment.

The electric motor for this mixer is available in either a 5 HP single-phase or 5 HP 3-phase configuration. The input voltage requirement for these motors is either 230 VAC or 440 VAC only.

ELECTRIC MOTOR CONNECTION

A 12 inch electrical cable (Figure 2) with a pigtail at one end is provided with the electrical motor for hookup to a power source. Table 1. shows the required NEMA connector for the desired motor horsepower rating. In addition, Table 2 also shows the matching NEMA approved connector for the required extension cord.

NOTE

It is strongly recommended that all electrical wiring be done by a **licensed electrician**. Special attention should be given to the electric switch as well as the over-and-under voltage protection devices as per regulations set forth in the local electrical safety code handbook.

Table 2. Electric Motor Wiring Information

Motor Horsepower Rating	230 Volt - Single Phase	
	NEMA Plug Connector	Mating NEMA Receptacle Connector
3 HP	L6-20P P/N 940539	L6-20R P/N 940540
5 HP	L6-30P P/N 940547	L6-30R P/N 940548

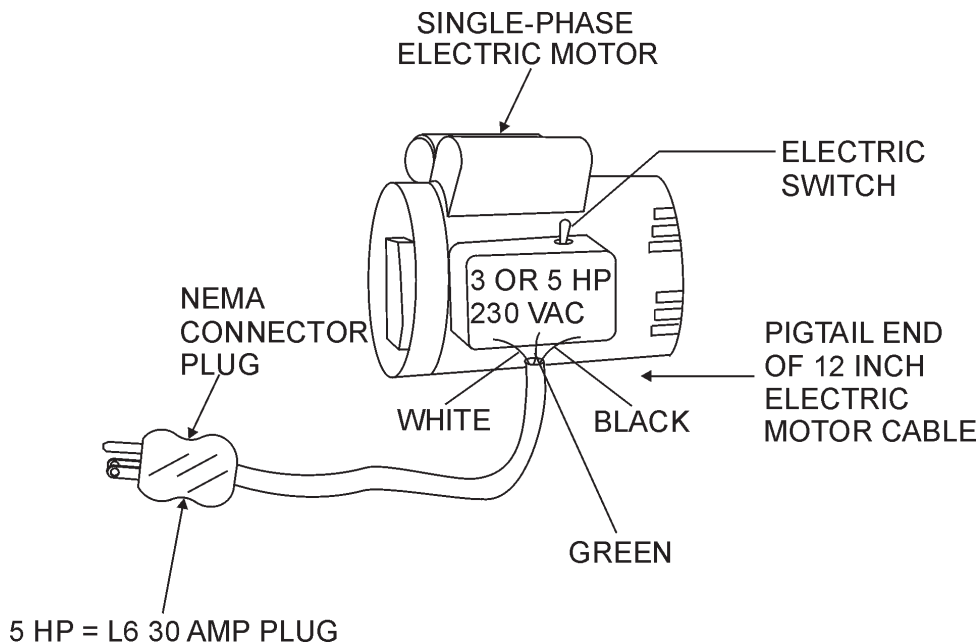

Figure 2. Single Phase Electric Motor with 12 inch Pigtail Cable

NOTE

Before towing, check with local and state laws for proper compliance.

The tow bar and chain must be properly attached to the mixer and towing vehicle prior to towing. Refer to the following installation instruction:

Step 1.

Insert the Draw Bar into the main frame. Secure, utilizing the 3/4" bolt (grade 5) and nylock nut. Tighten to 100 foot pounds.

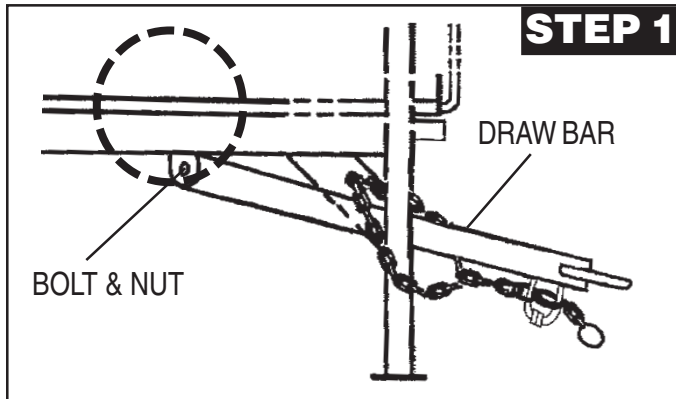

Step 2.

Install the chain through the hole located between the frame gusset and frame angle. Loop the chain together and place under the Draw Bar. Secure with connector link.

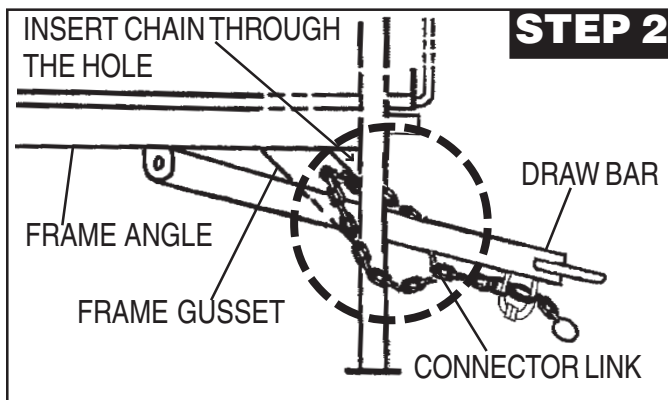

Step 3.

Extend the chain along the length of the Draw Bar, remove excess chain (slack) and secure to bottom connector link. Secure the chain to the towing vehicle, using the connector link.

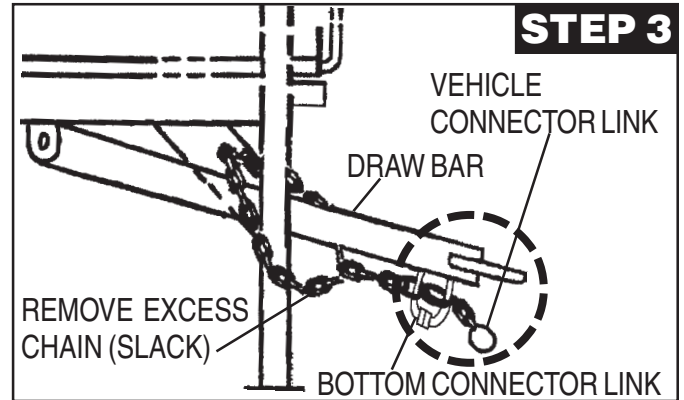

NOTE

It is critical that the length of the chain be properly adjusted, to prevent the **Draw Bar** and the front mixer stand from dropping to the ground (contact) in the event the Draw Bar becomes disconnected from the towing vehicle.

If a new safety chain is required use P/N 13363. For a new connector link use P/N 01004.

CAUTION:

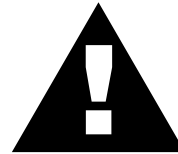

■ Check the following before towing:

BALL HITCH COUPLER

1. Check vehicle hitch, ball, and coupler for signs of wear or damage. Replace any parts that are worn or damaged before towing.
2. Use only the 2" ball diameter as indicated on your coupler. Use of any other ball diameter will create an extremely dangerous condition which can result in separation of the coupler and ball or ball failure.
3. Be sure the coupler is secured to the hitch ball and the lock lever is down tight and locked.
Recheck tightness again after towing about 50 miles.
4. Check that trailer safety chains are properly connected.

EM-120SM — PADDLE BLADE ADJUSTMENT

STEEL DRUM

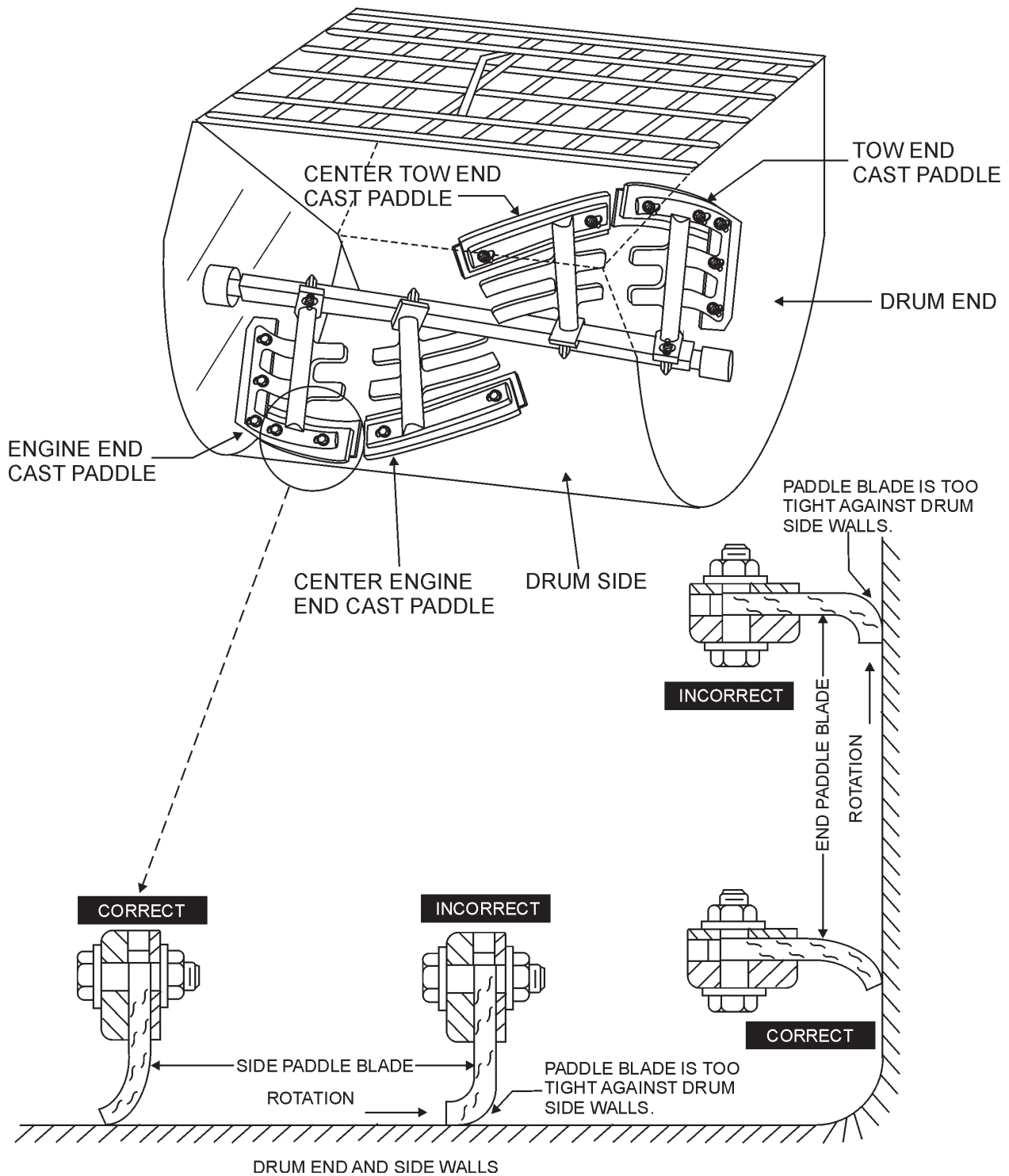

Figure 3. Paddle Blade Adjustment, Steel Drum

This section is intended to assist the operator with the initial start-up of the EM-120SM mixer. It is extremely important that this section be read carefully before attempting to use the mixer in the field.

DO NOT use your mixer until this section is thoroughly understood.

CAUTION:



Failure to understand the operation of the EM-120SM mixer could result in severe damage to the mixer or personal injury.

See Figure 1 (Page 10) for the location of any control referenced in this manual.

LUBRICANTS

ENGINE OIL

1. Remove the engine oil dipstick from its holder.
2. Determine if the engine oil is low, add correct amount of engine oil to bring oil level to a normal safe level.

CLUTCH OIL

1. Check the oil level in the clutch compartment, fill with 30 SAE engine oil if needed.

REDUCTION GEAR OIL

1. Check the oil level in the reduction gear compartment, fill with 90 SAE transmission oil if needed.

ZERK GREASE FITTINGS

1. Check the zerk grease fittings at each end of the mixing drum. These grease fittings lubricate the dumping mechanism. If the dumping handle is stiff or hard to move lubricate these fittings.

FUEL

1. If your mixer has a gasoline engine, determine if the engine fuel is low. If fuel is low, remove the fuel filler cap and fill with **unleaded** gasoline.

CAUTION:



Handle fuel safely. Motor fuels are highly **flammable** and can be dangerous if mishandled. **DO NOT** smoke while refueling. Do not attempt to refuel mixer if the engine is hot or running. Always allow engine to **cool** before refueling.

STARTING THE ENGINE (gasoline only)

The following steps outline the procedure for starting the engine. Depending on the type of engine employed in the mixer the steps may vary slightly. If your mixer has an electric motor disregard this section.

1. Move the fuel shut-off lever (Figure 4) to the **ON** position.

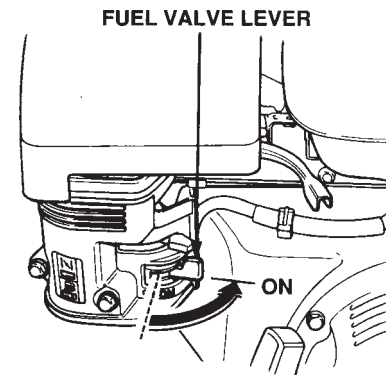

Figure 4. Fuel Shut-OFF Lever

2. To start a cold engine, move the choke lever (Figure 5) to the **CLOSED** position.

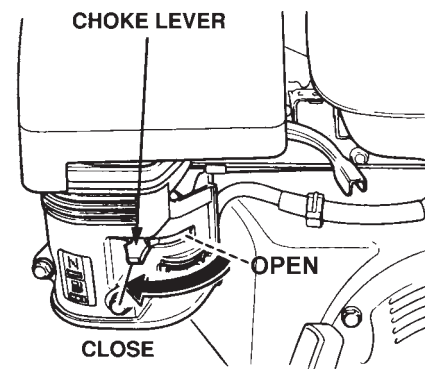

Figure 5. Choke Lever

3. Move the throttle lever (Figure 6) away from the slow position, about 1/3 of the way toward the fast position.

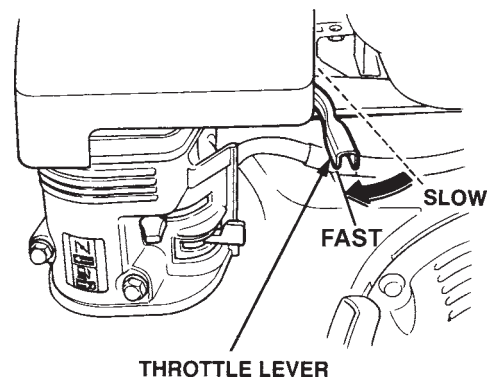

Figure 6. Throttle lever Lever

- Turn the engine switch (Figure 7) to the ON position.

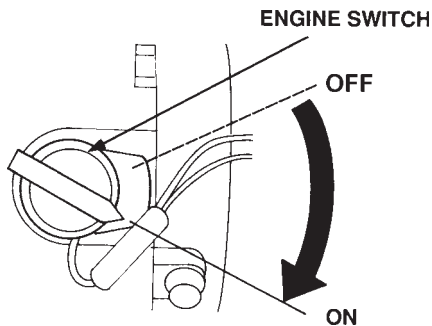

Figure 7. Engine ON/OFF Switch

- Located on the engine cover is the main **start/stop** switch (Figure 8). Pull this switch outward to start the engine.

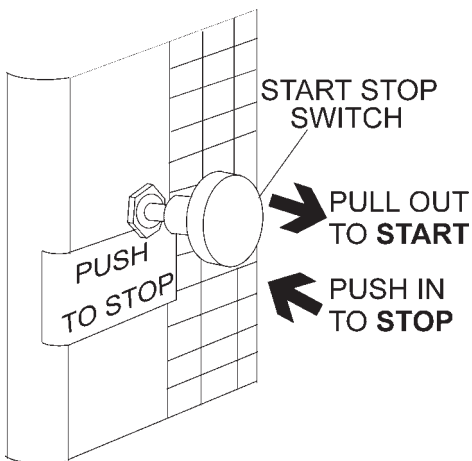

Figure 8. Main ON/OFF Switch

- Pull the **starter grip** (Figure 9) lightly until you feel resistance, then pull briskly. Return the starter grip gently. Push the clutch lever forward, toward the tow tongue end of the mixer. When engine starts adjust throttle lever so that paddle shaft inside mixer rotates between 30 - 40 RPM's. The number of RPM's will vary depending on engine type and load.

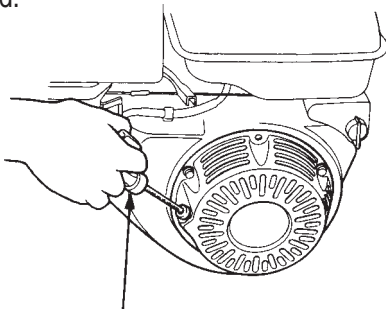

Figure 9. Starter Grip

MIXING

- The paddle shaft inside the drum should be rotating at this time.
- Lift the mixing bag compound onto the steel grate over the bag cutter and let the contents fall into the drum.
- Add water, and mix compound to desired consistency, then dump.

NOTE

Be sure to stand clear of the **dump handle** when the mixer is operational. Any binding of material between the mixer blades and the drum will cause the drum handle to move to the discharge position, thus causing bodily harm.

STARTING THE ELECTRIC MOTOR

- After the electric motor has been connected to a power source by a licensed electrician it can then be ready for use.
- Set the electric motor's ON/OFF switch (Figure 10) to the **ON** position.

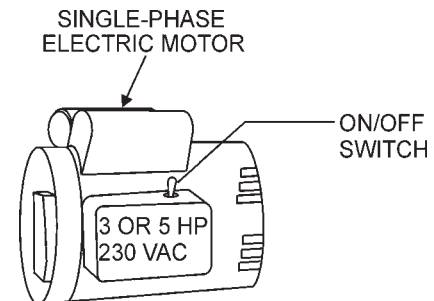

Figure 10. Main ON/OFF Switch

- Engage the clutch lever and verify that the paddle shaft is rotating, then follow steps 1, 2 and 3 outlined in the mixing section above.

STOPPING THE MIXER (gasoline)

- Push the main **start/stop** switch (Figure 8) inward to stop the engine.
- Turn the fuel shut-off valve to the **OFF** position.
- Disconnect the spark plug.
- Clean drum of all debris and foreign matter.

STOPPING THE MIXER (electric)

- Place the electric motor's **start/stop** switch (Figure 10) in the **OFF** position.
- Disconnect the electric motor's extension cord from its power source.
- Clean drum of all debris and foreign matter.

WHEEL BEARINGS

After every 3 months of operation, remove the hub dust cap and inspect the wheel bearings. Once a year, or when required, disassemble the wheel hubs remove the old grease and repack the bearings forcing grease between rollers, cone and cage with a good grade of high speed wheel bearing grease (never use grease heavier than 265 A.S.T.M. penetration ("No. 2.") Fill the wheel hub with grease to the inside diameter of the outer races and also fill the hub grease cap.

Reassemble the hub and mount the wheel. Then tighten the adjusting nut, at the same time turn the wheel in both directions, until there is a slight bind to be sure all the bearing surfaces are in contact.

Then back-off the adjusting nut 1/6 to 1/4 turn or to the nearest locking hole or sufficiently to allow the wheel to rotate freely within limits of .001" to .010" end play. Lock the nut at this position. Install the cotter pin and dust cap, and tighten all hardware.

IMPORTANT -DRUM HEAD SEAL CARE

On each end of the mixing drum is a drum head containing self adjusting paddle shaft seals. These seals consist of packing rings, split glands and spring actuated adjusters. A properly maintained seal prevents material from working around the paddle shaft, causing excessive wear. The following is a suggested procedure of maintenance for protection of the paddle shaft and bearings:

- A. Keep the drum head clean of plaster built up, so the spring adjusters will be free to work.
- B. Replace with one new ring of packing and waterproof grease when split gland or pressure plate is about to bottom out against the end of the drum.

New Packing

When the old packing is to be completely replaced, coat shaft and packing generously with a good grade of waterproof grease and insert packing rings. Tighten the two spring adjuster nuts on each end until the spring is compressed to 1-3/4 inches or the top of the adjusting nut is even with the top of the drum head.

Also, whenever the paddle shaft is removed, new waterproof grease should be packed around the ball bearings in the drum heads before reinstalling the shaft. Fill the cavity completely.

CLUTCH REDUCTION ASSEMBLY LUBRICATION

The clutch reduction assembly has two separate compartments. Each of which must be filled with its proper lubricant and checked at regular intervals.

The **clutch compartment** should be filled with a good grade of number 30 SAE engine oil which can be poured through the filler hole located just above the clutch inspection door on the opposite side of the transmission. Fill the clutch compartment with 30 SAE engine oil until it overflows the oil level plug located on the shifter side of the clutch compartment. Check this oil level every two or three months and add oil as required. Drain and refill once a year.

The **reduction gear, upper compartment** should be filled with number 90 SAE oil, as used in automobile transmissions. The filler plug is at the top of the reduction gear case and the oil level plug is on the same side of the case as the clutch lever. Fill the reduction gear compartment with 90 SAE transmission oil until it overflows the oil level plug. Check this oil level every two or three months and add oil as required. Drain and refill once a year..

PADDLE SHAFT BEARINGS

The paddle shafts in the Essick EM120PM mixers rotate in sealed ball bearings, which require no additional lubrication as they are packed and sealed at the factory.

There is, on each end of the mixing drum, an zerk grease fitting. Oil these fittings two or three times each week as they lubricate the dumping mechanism of the mixing drum.

CAUTION:



■ **Failure** to lubricate the zerk grease fittings two or three times a week will cause the dumping mechanism to stiffen, making the mixer hard to dump.

BOLT CONNECTOR

A 5/8 " x 4 1/4" bolt is used as a connector pin located between the reduction gear assembly and the paddle shaft. It is designed to protect the transmission in the event a rock or other object should get caught between the paddle blade and the drum, this pin may shear. It is recommended that an extra bolt be kept on hand so as to quickly make a replacement, if necessary.

NOTE

This connector pin bolt is special. When replacing this bolt consult the parts section of this manual for the correct part number.

BEARING BRACKET

Grease the bearing bracket every month.

CLEANING

Always disconnect the spark plug wire before cleaning the inside of the drum.

Never pour or spray water over the gasoline engine or electric motor.

For consistent performance, long life and high quality mixing, thoroughly clean the mixer inside and out at the end of each day's operation. To prevent lumps of dried mortar from forming and contamination of future batches, do not allow a buildup of materials to form on the blades or anywhere inside the drum.

Clutch Adjustment Mechanical 12 CF Mixer

If the rotating mixing paddles appear to be losing rotational speed, it may be necessary to adjust the clutch. For optimum performance Multiquip recommends 35-55 lbs. applied pressure to the hand clutch lever. After the first initial operating hours (8) check the clutch for proper engagement pressure.

Clutch Adjustment Procedure

CAUTION:



Always stop the engine, disconnect the spark plug or electrical power cord before attempting this procedure.

1. To gain access to the " Gear Reduction Compartment" remove the four 9/16-inch hex head bolts that secure the hood to the engine and remove engine hood.
2. Drain the clutch compartment oil by removing the magnetic 3/8 plug located at the bottom of the Gear Reduction Assembly.
3. To gain access to the "**clutch inspection door**" remove the six 1/2-inch capscrews and lockwashers that secure the clutch inspection door. Remove door and gasket.

NOTE

The Gear Reduction Compartment consist of two compartments, a lower and upper. The **lower** compartment houses the clutch, the **upper** compartment contains the actual gear reduction. Remember each compartment requires a different type of lubricating oil.

4. Check that the clutch is disengaged by pulling the shifter lever towards the rear of the mixer.
5. Refer to Figure 12 for steps 5A through 5G:
 - A. Rotate the clutch using the recoil starter until the **adjustment lock** (Figure 11) P/N EM934040 is visible. Using a flat blade screwdriver loosen the adjustment bolt just enough to release the adjustment lock.
 - B. Using a punch, rotate the **adjusting ring** P/N EM 934045 one notch at a time in the counter-clockwise direction until a firm 35 to 55 lbs. pressure is felt when engaging the clutch lever (the lever should snap into the engaged position).

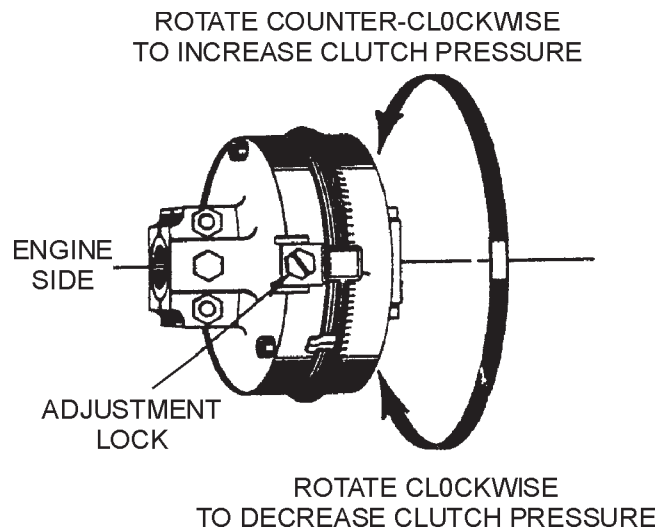

Figure 11. Clutch Adjustment Lock Location

NOTE

If the clutch cannot be adjusted, it may be necessary to inspect or replace the clutch.

- C. When the clutch has been satisfactorily adjusted reinstall the **adjustment lock** P/N EM 934040 and tighten lock bolt.
- D. Reinstall the **clutch inspection door** using the six 1/2-inch capscrews and lockwashers, and also check that the gasket is not worn or broken.
- E. When the clutch has been satisfactorily adjusted reinstall the **adjustment lock** P/N EM 934040 and tighten lock bolt.
- F. Remove the 3/8-inch square head pipe plug located on the lower clutch compartment. Refill the clutch compartment with 2 1/4 quarts of SAE 30 motor oil to the level of the plug. When done reinstall plug.
- G. Reinstall spark plug wire or electric power cord. Start engine, check for proper clutch engagement and inspect for any oil leaks.

NOTE

Any questions regarding the above procedure please contact the Multiquip Service Dept. at 1-800 421-1244.

EM-120SM — TROUBLESHOOTING (ENGINE)

Practically all breakdowns can be prevented by proper handling and maintenance inspections, but in the event of a breakdown, please take a remedial action following the

diagnosis based on the Engine Troubleshooting (Table 3) information shown below and on the proceeding page. If the problem cannot be remedied, please leave the unit just as it is and consult our company's business office or service

TABLE 3. ENGINE TROUBLESHOOTING

SYMPTOM	POSSIBLE PROBLEM	SOLUTION
Poor starting	Inspect carburetor to see if fuel is reaching it?	Check fuel line
	No Fuel?	Add Fuel
	Water in fuel tank?	Flush or replace fuel tank.
	Fuel filter clogged?	Replace fuel filter
	Stuck carburetor?	Check float mechanism.
	Spark plug is red?	Spark plug is fouled. Check transistor ignition unit.
	Spark plug is blue-white?	Insufficient compression, injected air leaking. Carburetor jets are clogged (overflow).
	No spark present at tip of spark plug?	Transistor ignition unit broken, high voltage cord cracked or broken. Start/Stop switch broken. Replace spark plug if fouled.
	No oil?	Add oil as required.
	Oil pressure alarm lamp blinks upon starting?	Check Automatic shutdown circuit "oil sensor".
Insufficient power output "no compression"	Engine will not turn over?	Replace cylinder and piston and if necessary axel joint.
	Cylinder head connecting bolts loose?	Tighten cylinder head connecting bolts.
	Cylinder head gasket damaged?	Replace cylinder head gasket.
	Malfuction of valve seat?	Re-seat valves.
	Spark plug is loose?	Replace spark plug.
	Worn piston rings?	Replace piston rings.
Insufficient power output "compression"	Malfuction in air-cleaner system, air filter clogged?	Clean or replace air filter.
	Air leaking in from interface between carburetor and cylinder head?	Tighten bolts between carburetor and cylinder head. Replace cylinder head gasket.
	Malfuction in fuel system?	Clean or replace fuel filter. Clean or replace carburetor. Check carburetor float.

EM-120SM — TROUBLESHOOTING (ENGINE/MIXER)

TABLE 3. ENGINE TROUBLESHOOTING (CONTINUED)

SYMPTOM	POSSIBLE PROBLEM	SOLUTION
Insufficient power output "compression" and overheats	Malfunction in cooling fan?	Check or replace cooling fan.
	Air in-take filter clogged?	Clean or replace air in-take filter.
Burns to much fuel	Over accumulation of exhaust products?	Clean and check valves. Check muffler, replace if necessary.
	Wrong spark plug?	Replace spark plug with manufactures suggested type spark plug.
Exhaust color is continiously "WHITE"	Lubricating oil is wrong viscosity?	Replace lubricating oil with correct viscosity.
	Worn rings?	Replace rings
Exhaust color is continiously "BLACK"	Air cleanner clogged?	Clean or replace air cleaner.
	Choke valve has not been set to the correct position?	Adjust choke valve to the correct position.
	Carburetor defective, seal on carburetor broken?	Replace carburetor or seal.
	Poor carburetor adjustment "engine runs too rich?"	Adjust carburetor.

TABLE 4. MIXER TROUBLESHOOTING

SYMPTOM	POSSIBLE PROBLEM	SOLUTION
Blades will not rotate.	Broken connector pin?	Replace connector pin. Use P/N 963157 when ordering.
	Defective or mis-adjusted clutch?	Adjust or replace clutch.
Material leaking from drum ends.	Worn or defective paddle shaft seals?	Adjust or replace seals.
Drum difficult to discharge (tilt)	Malfunction in air-cleaner system, air filter clogged?	Clean or replace air filter.
	Defective or worn drum support brackets?	Apply grease to bracket or replace.
	Blades adjusted too tight.	Adjust blades until they almost touch side walls of drum.

EXPLANATION OF CODE IN REMARKS COLUMN

How to read the marks and remarks used in this parts book.

Section 1: Items Found In the “Remarks” Column

Serial Numbers-Where indicated, this indicates a serial number range (inclusive) where a particular part is used.

Model Number-Where indicated, this shows that the corresponding part is utilized only with this specific model number or model number variant.

Section 2: Items Found In the “Remarks” Column

Serial Numbers-Where indicated, this indicates a serial number range (inclusive) where a particular part is used.

Model Number-Where indicated, this shows that the corresponding part is utilized only with this specific model number or model number variant.

Section 3: Items Found In the “Items Number” Column

All parts with same symbol in the number column, *, #, +, %, or ■, belong to the same assembly or kit.

Note: If more than one of the same reference number is listed, the last one listed indicates newest (or latest) part available.

NOTE

The contents of this parts catalog are subject to change without notice.

EM-120SM— SUGGESTED SPARE PARTS

EM-120SM 1 TO 3 UNITS

Qty.	P/N	Description
6	491010	RUBBER LATCH ASSY.
1	EM200293	PADDLE ARM TOW SIDE
1	EM200294	PADDLE ARM CENTER TOW SIDE
1	EM200295	PADDLE ARM CENTER ENGINE SIDE
1	EM200296	PADDLE ARM ENGINE SIDE
3	EM200863	RUBBER BLADE KIT (STEEL DRUM)
3	EM204625	RUBBER BLADE KIT (PLASTIC DRUM)
2	EM200297	U-BOLT
2	EM200268	U-BOLT
2	EM902153	BEARING, PADDLE SHAFT
3	EM963157	CONNECTOR BOLT
1	EM934041	CLUTCH, DRIVEN MEMBER
12	EM200301	PACKING RINGS
4	EM200286	CARRIAGE BOLT
4	EM200794	ADJUSTMENT SPRING
4	EM200285	GLAND

EM-120SM 5 TO 10 UNITS

Qty.	P/N	Description
10	491010	RUBBER LATCH ASSY.
2	EM200293	PADDLE ARM TOW SIDE
2	EM200294	PADDLE ARM CENTER TOW SIDE
2	EM200295	PADDLE ARM CENTER ENGINE SIDE
2	EM200296	PADDLE ARM ENGINE SIDE
6	EM200863	RUBBER BLADE KIT (STEEL DRUM)
3	EM204625	RUBBER BLADE KIT (PLASTIC DRUM)
4	EM200297	U-BOLT
4	EM200268	U-BOLT
4	3530	PADDLE SHAFT, SEAL KIT
4	EM902153	BEARING, PADDLE SHAFT
5	EM963157	CONNECTOR BOLT
2	EM934041	CLUTCH, DRIVEN MEMBER
60	EM200301	PACKING RINGS
20	EM200286	CARRIAGE BOLT
20	EM200794	ADJUSTMENT SPRING
20	EM200285	GLAND

EM-120SM — MIXING DRUM ASSY.

MIXING DRUM ASSY.

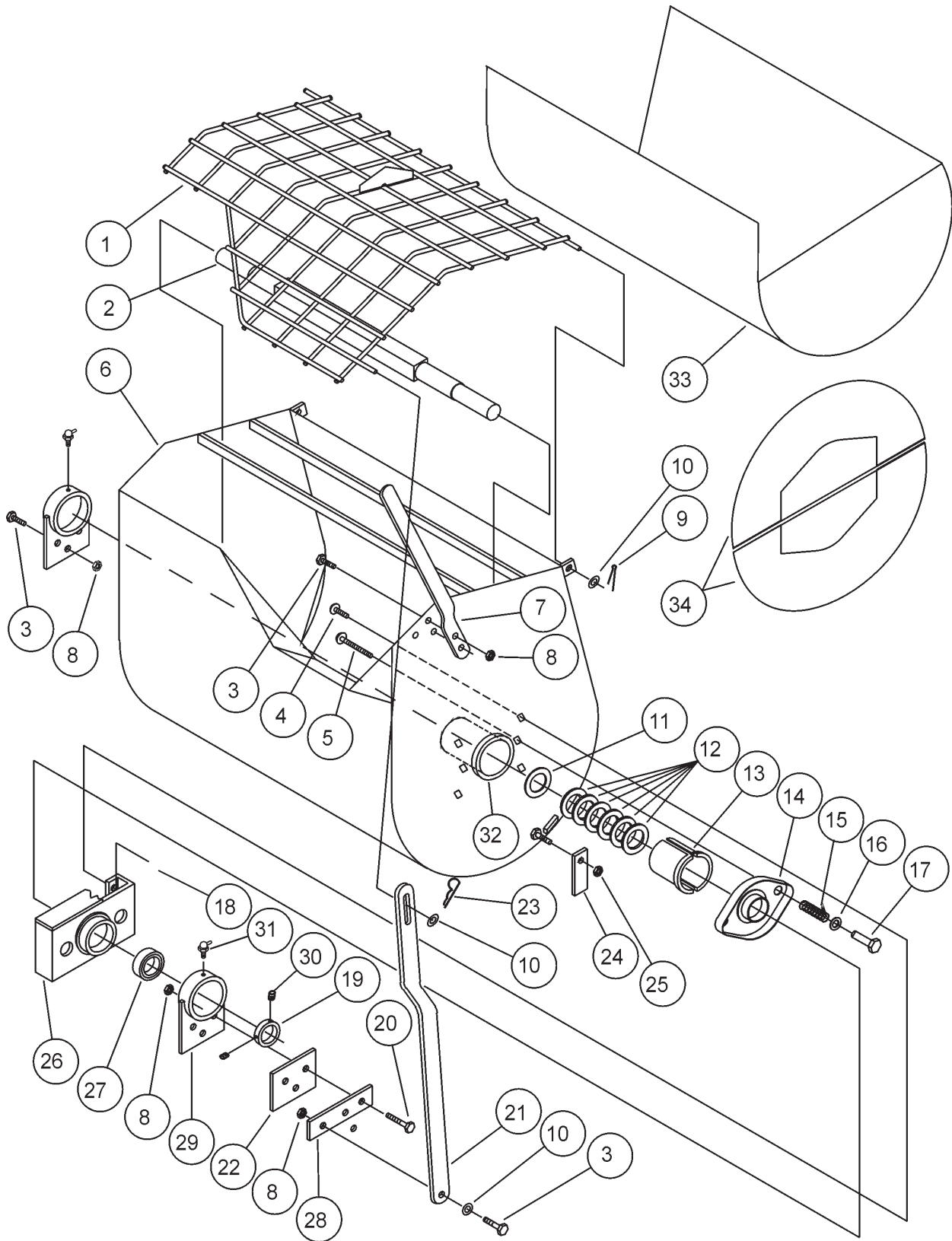

EM-120SM — MIXING DRUM ASSY.

MIXING DRUM ASSY.

<u>NO</u>	<u>PART NO</u>	<u>PART NAME</u>	<u>QTY.</u>	<u>REMARKS</u>
1	EM203449	DRUM GRILL	1	
1	EM202122	DRUM GRILL-MOVABLE (NOT SHOWN)	1	
2	EM200333	PADDLE SHAFT	1	
3	EM963692	HHCS 1/2-13 x 1.1/2"	6	
4	EM966048	CARRIAGE BOLT 3/8-16 x 1.1/4"	8	
5	EM200286	CARRIAGE BOLT 3/8-16 x 3 FULL THREAD	4	
6	EM201618	DRUM	1 INCL. ITEMS W/ *
7*	EM201537	DUMP LEVER	1	
8	10176	LOCK NUT 1/2-13	9	
9	EM924015	COTTER PIN 3/16 x 1"	2	
10	13211	FLAT WASHER 1/2"	4	
11	EM200303	PACKING RING FOLLOWER	2	
12	EM200301	SHAFT PACKING RING	12	
13	EM200285	HALF GLAND PACKING	4	
14	EM200288	PACKING GLAND PRESSURE PLATE	2	
15	EM200794	GLAND ADJUSTMENT SPRING	4	
16	EM923157	FLAT WASHER 5/8"	4	
17	EM200287	SPECIAL ADJUSTING NUT 3/8-16	4	
18	10133	LOCK NUT 3/8-16	8	
19	EM200018	PADDLE SHAFT COLLAR	2	
20	6159A	HHCS 1/2-13 x 2"	3	
21	EM203344	GRILL OPENING BAR	1	
22	EM200079	BEARING BRKT. SHIM .135" THICK	AR	
22	EM200080	BEARING BRKT. SHIM .187" THICK	AR	
23	7170	HITCH CLIP PIN	1	
24*	EM201731	DRUM LATCH	1	
25	EM969023	LOCK NUT 5/8-11	1	
26	EM201648	DRUM HEAD	2	
27	EM902153	BALL BEARING	2	
28	203335	GRILL CLOSING BAR HINGE	1	
29	EM201786	BEARING BRKT.	2 INCL. ITEMS W/#
30	EM961066	SHSS 3/8-16 x 3/8"	4	
31#	EM916006	GREASE FITTING 90 DEG.	2	
32	EM200237	PACKING BOX	2	
33	EM202161	DRUM LINER	1	
34	EM202607	DRUM END LINER	2	
	EM201842	DRUM & SHAFT ASSY.	1 INCLUDES ALL PARTS LISTED PAGES 25& 27 EXCEPT ITEMS 33 & 34 PAGE 25

EM-120SM — PADDLE SHAFT ASSY.

PADDLE SHAFT ASSY.

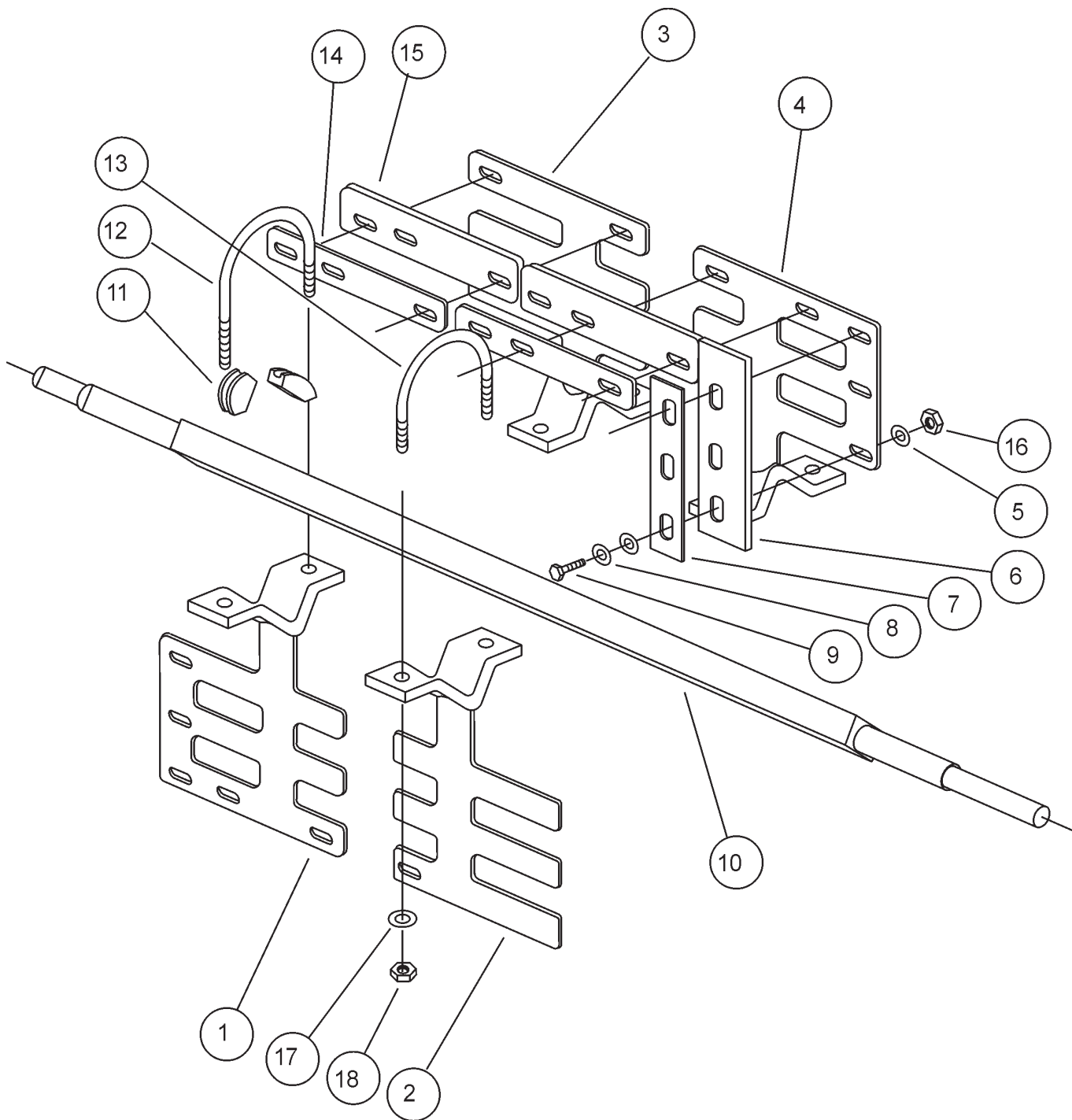

EM-120SM — PADDLE SHAFT ASSY.

PADDLE SHAFT ASSY.

<u>NO</u>	<u>PART NO</u>	<u>PART NAME</u>	<u>QTY.</u>	<u>REMARKS</u>
1	EM200293	TOW END CAST PADDLE	1	
2	EM200294	CENTER TOW END CAST PADDLE	1	
3	EM200295	CENTER ENGINE END CAST PADDLE	1	
4	EM200296	ENGINE END CAST PADDLE	1	
5#	0300B	FLAT WASHER 5/16"	7	
6#	EM200213	SIDE RUBBER WIPER	1	
7#	EM203433	SIDE SCRAPER BLADE	1	
8#	0161C	LOCK WASHER 5/16"	7	
9#	1207	HHCS 5/16-18 x 1.3/4"	7	
10	EM200333	PADDLE SHAFT	1	
11	EM200292	PADDLE ARM INSERT CASTING	4	
12	EM200297	END PADDLE U-BOLT	1	
13	EM200268	CENTER PADDLE U-BOLT	1	
14#	EM203432	TOP SCRAPER BLADE	2	
15#	EM200212	TOP RUBBER WIPER	2	
16	0161D	HEX NUT 5/16-18	7	
17	5054A	LOCK WASHER 1/2"	4	
18	EM968011	HEX NUT 1/2-13	4	
	EM200863	RUBBER BLADE KIT	1	INCLUDES ITEMS W/#

EM-120SM — FRAME ASSY.

FRAME ASSY.

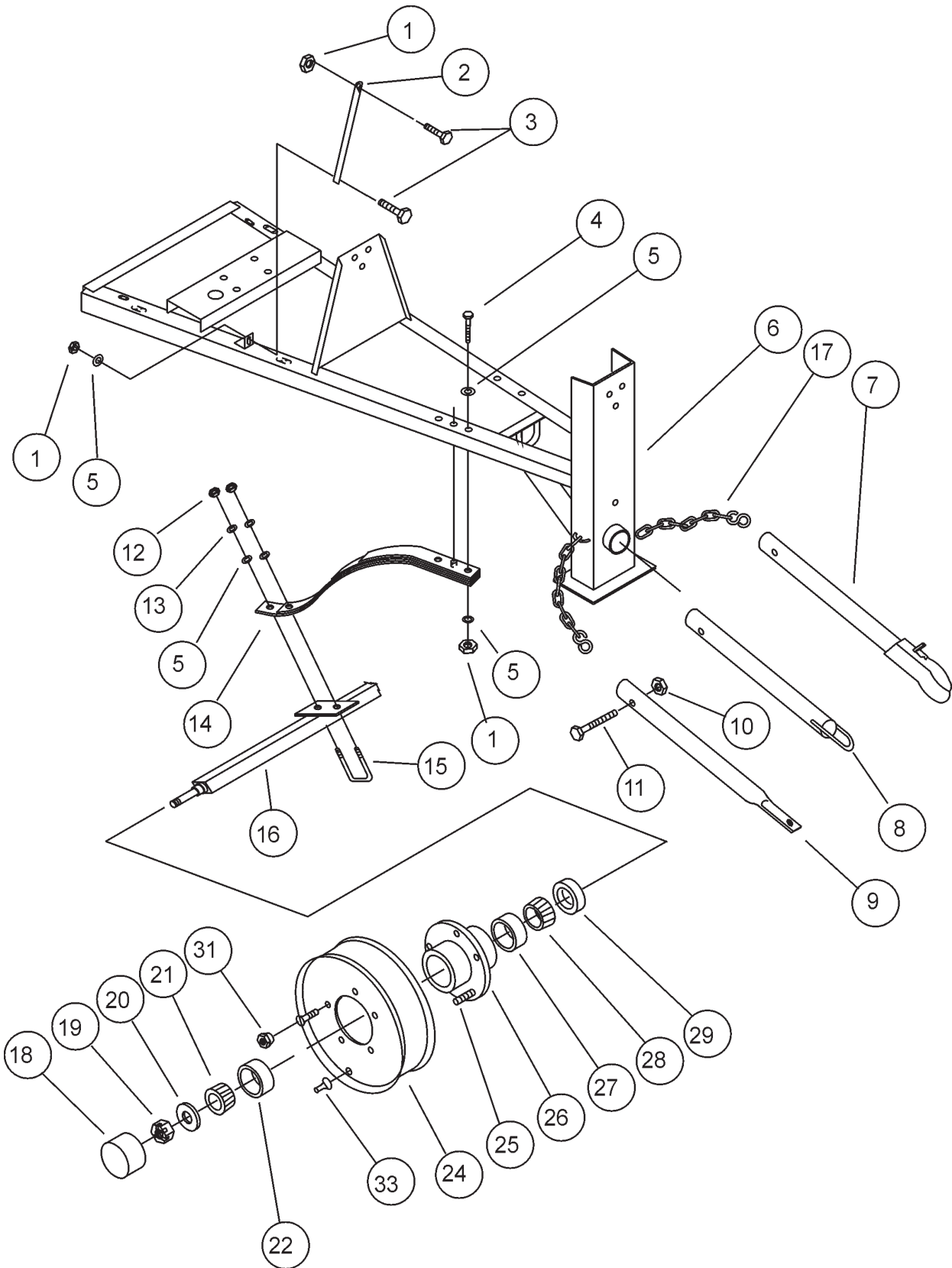

FRAME ASSY.

<u>NO</u>	<u>PART NO</u>	<u>PART NAME</u>	<u>QTY.</u>	<u>REMARKS</u>
1	10176	LOCK NUT 1/2-13	8	
2	EM204086	TRANSMISSION SUPPORT BAR	2	
3	5218	HHCS 1/2-13 x 1.1/2"	4	
4	2549	HHCS 1/2-13 x 3"	4	
5	0447	FLAT WASHER 1/2"	14	
6	EM202765	FRAME W/A	1	
7	EBC-1	BALL HITCH TOW BAR	1	
8	EDC-1	PINTLE EYE TOW BAR	1	
9	ELC-1	PIN HOLE TOW BAR	1	
10	5070B	LOCK NUT 3/4-10	1	
11	EM963580	HHCS 3/4-10 x 4.1/2"	1	
12	8244	HEX NUT 1/2-20	4	
13	5054A	LOCK WASHER 1/2"	4	
14	EM201225	AXLE SPRING	2	
15	EM966204	SQUARE AXLE U-BOLT 1.1/2"	2	
16	EM202983	AXLE	1	
17	3148	SAFETY CHAIN ASSY.	2	
18*	EM941278	GREASE CAP	2	
19	EM968302	AXLE NUT	2	
20	EM923161	AXLE WASHER	2	
21*	EM903113	OUTER BEARING CONE	2	
22*	EM903012	OUTER BEARING CUP FOR ORIGINAL HUB	2	
24	EM941257	WHEEL -13 x4.1/2- 5 ON 4.1/2" BC	2	
25*	EM941279	SERRATED WHEEL STUD	10	
26	EM941277	HUB COMPLETE	2	INCLUDES ITEMS W/*
27*	EM903169	INNER BEARING CUP	2	
28*	EM906168	INNER BEARING CONE	2	
29*	EM914324	SEAL	2	
31*	EM941280	WHEEL NUT	10	
33	EM942052	VALVE STEM	2	

CAB ASSY.

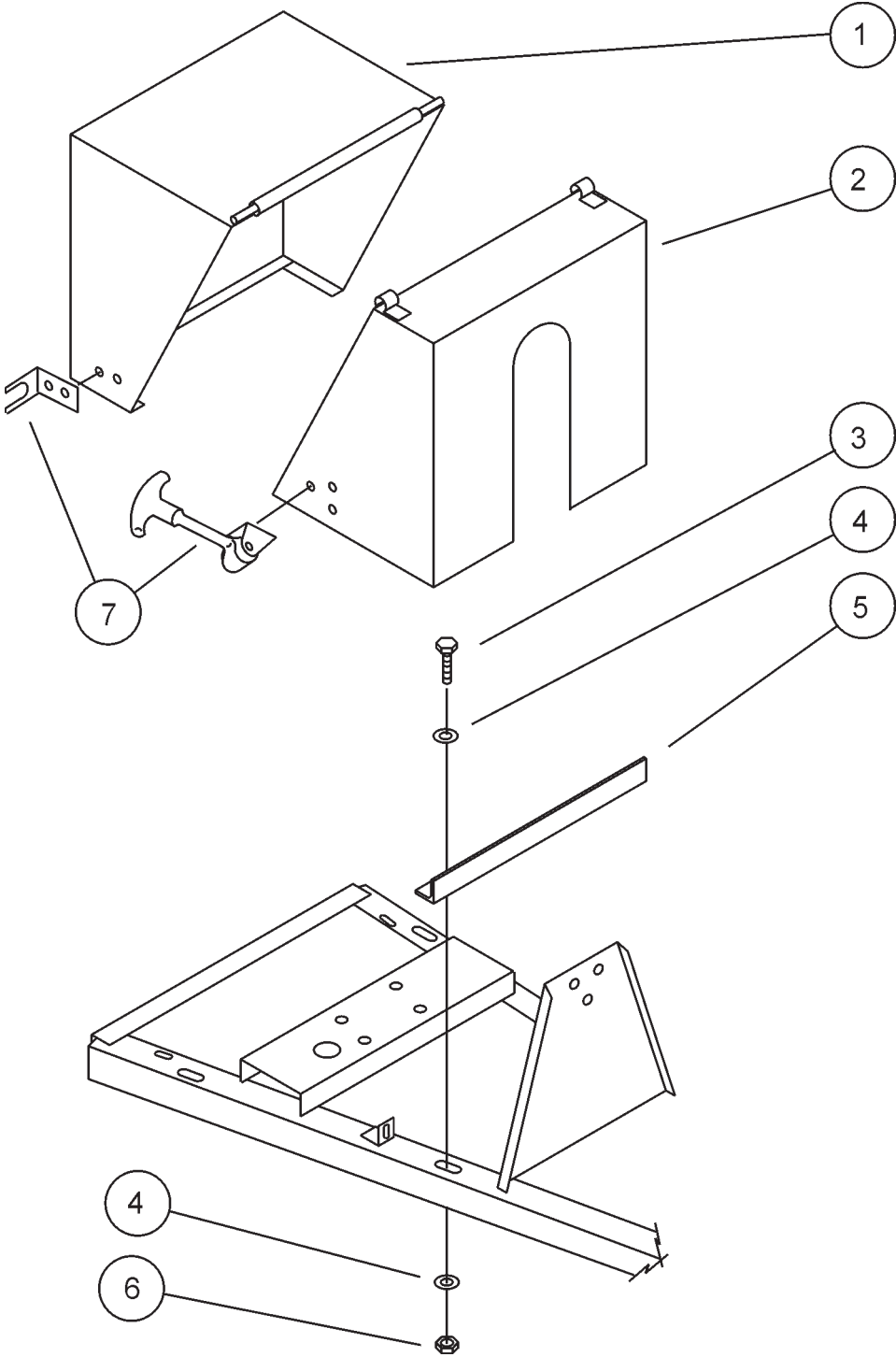

CAB ASSY.

<u>NO.</u>	<u>PART NO.</u>	<u>PART NAME</u>	<u>QTY.</u>	<u>REMARKS</u>
1#*	EM203141	CAB DOOR W/A	1	
2#*	EM202956	FRONT CAB BODY-GAS ENG.	1	
2#*	EM202910	FRONT CAB BODY-ELECT. ENG.	1	
3	1284	HHCS 3/8-16 x 1.1/2"	4	
4	4001	FLAT WASHER 3/8"	8	
5	EM202771	CAB FRONT SUPPORT ANGLE	1	
6	10133	LOCK NUT 3/8-16	4	
7#*	EM929025	LATCH ASSY.	2	
	EM202957	COMPLETE CAB ASSY.....	1 INCLS. ITEMS W/*
	EM202911	COMPLETE CAB ASSY.....	1 INCLS. ITEMS W/#

EM-120SM — WISCONSIN ENGINE ASSY.

WISCONSIN ENGINE ASSY.

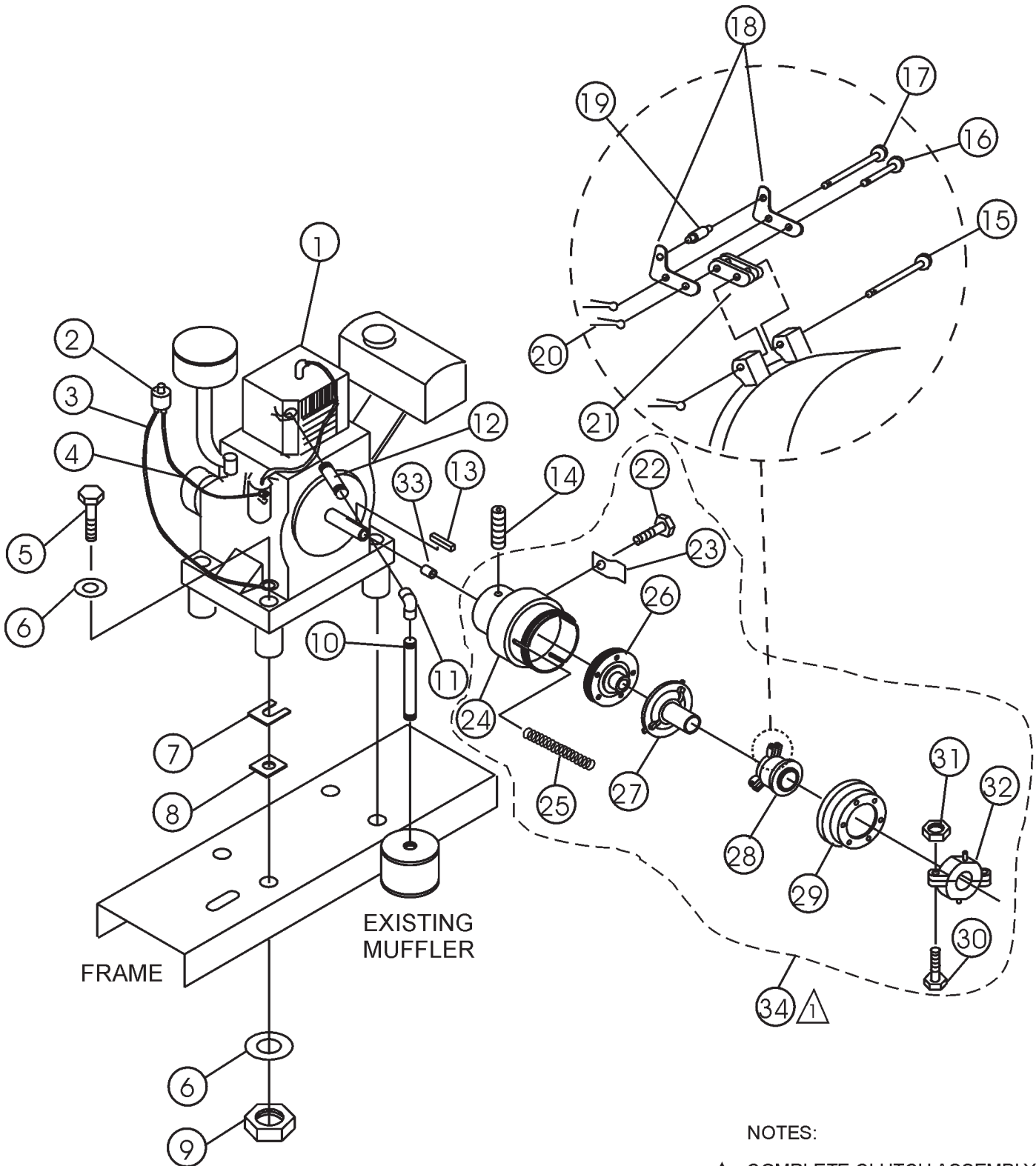

NOTES:

 COMPLETE CLUTCH ASSEMBLY, ITEM 34, P/N 934022 INCLUDES ALL ITEMS WITHIN OUTLINE.

EM-120SM — WISCONSIN ENGINE ASSY.

WISCONSIN ENGINE ASSY.

<u>NO</u>	<u>PART NO</u>	<u>PART NAME</u>	<u>QTY.</u>	<u>REMARKS</u>
1	EM937029	9.2 HP WISCONSIN ENGINE	1	
2	EM940734	KILL SWITCH	1	
3	EM203298	ENGINE KILL GROUND WIRE	1	
4	EM203299	ENGINE KILL WIRE	1	
5	0169	HHCS 3/8-16 x 3"	4	
6	10136	FLAT WASHER 3/8"	8	
7	EM100235	ENGINE SHIM .030	AR	
	EM100236	ENGINE SHIM .018	AR	
	EM100237	ENGINE SHIM .010	AR	
8	EM203007	ENGINE PAD .187	AR	
	EM203016	ENGINE PAD .135	AR	
	EM203017	ENGINE PAD .060	AR	
9	10133	LOCK NUT 3/8-16	4	
10	EM912104	1" PIPE NIPPLE x 10" LONG	1	
11	5081	1" 90 DEG. ELBOW	1	
12	EM912097	1" PIPE NIPPLE x 5" LONG	1	
13	EM010009	SQ KEY 1/4 x 1/4 x 1"	1	
14	EM961045	SHSS 5/16-18 x 1/2" NYLOC	1	
15*	EM925013	LEVER PIN	3	
16*	EM925018	SHORT LINK PIN	3	
17*	EM925016	LONG LINK PIN	3	
18*	EM959012	LEVER	6	
19*	EM934054	ROLLER	3	
20*	5117	COTTER PIN	9	
21*	EM934053	CONNECTING LINK	6	
22*	9503	SLOTTED HHCS 1/4-20 x 1/2"	1	
23*	EM934040	ADJUSTING LOCK	1	
24*	EM934039	CLUTCH HOUSING	1	
25*	EM918009	SPRING	3	
26*	EM934041	SPLINED CENTER W/FACING	1	
27*	EM934042	PRESSURE PLATE ASSY.	1	
28*	EM934043	RELEASE SLEEVE	1	
29*	EM934045	ADJUSTING RING	1	
30*	EM963289	BOLT	2	
31*	EM969009	LOCK NUT	2	
32*	EM934004	RELEASING BEARING ASSY.	1	
33	EM801570	PILOT BUSHING	1	
	EM934022	CLUTCH ASSY.	1 INCL. ITEMS W/*

EM-120SM — HONDA ENGINE ASSY.

HONDA ENGINE ASSY.

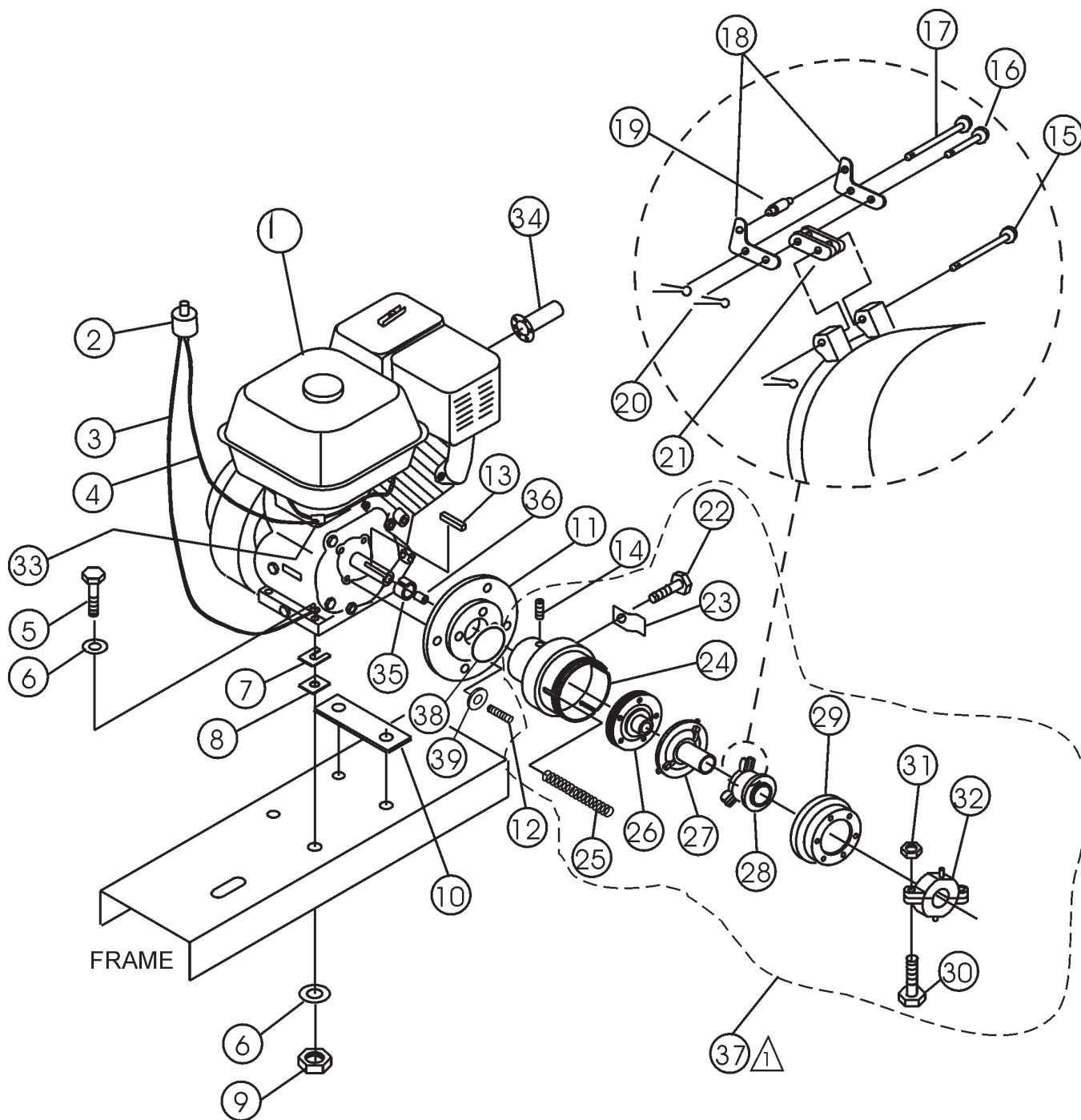

NOTES:

△ COMPLETE CLUTCH ASSEMBLY,
ITEM 37, P/N 934022 INCLUDES
ALL ITEMS WITHIN OUTLINE.

EM-120SM — HONDA ENGINE ASSY.

HONDA ENGINE ASSY.

<u>NO</u>	<u>PART NO</u>	<u>PART NAME</u>	<u>QTY.</u>	<u>REMARKS</u>
1	EM203456	11 HP HONDA ENGINE	1	
2	EM940734	KILL SWITCH	1	
3	EM203298	ENGINE KILL GROUND WIRE	1	
4	EM203035	ENGINE KILL WIRE	1	
5	9154	HHCS 3/8-16 x 1.3/4"	4	
6	10136	FLAT WASHER 3/8"	8	
7	EM100235	ENGINE SHIM .030	AR	
	EM100236	ENGINE SHIM .018	AR	
	EM100237	ENGINE SHIM .010	AR	
8	EM203007	ENGINE PAD .187	AR	
	EM203016	ENGINE PAD .135	AR	
	EM203017	ENGINE PAD .060	AR	
9	10133	LOCK NUT 3/8-16	4	
10	EM204550	MOTOR MOUNT	2	
11	EM203038	ADAPTER KIT	1 INCLUDES ITEMS W/*
12*	11090	STUD, 3/8 SHC	4	
13	EM927066	SQ KEY	1	
14	EM961045	SHSS 5/16-18 x 1/2" NYLOC	1	
15#	EM925013	LEVER PIN	3	
16#	EM925018	SHORT LINK PIN	3	
17#	EM925016	LONG LINK PIN	3	
18#	EM959012	LEVER	6	
19#	EM934054	ROLLER	3	
20#	5117	COTTER PIN	9	
21#	EM934053	CONNECTING LINK	6	
22#		SLOTTED HHCS 1/4-20 x 1/2"	1	
23#	EM934040	ADJUSTING LOCK	1	
24#	EM934039	CLUTCH HOUSING	1	
25#	EM918009	SPRING	3	
26#	EM934041	SPLINED CENTER W/FACING	1	
27#	EM934042	PRESSURE PLATE ASSY.	1	
28#	EM934043	RELEASE SLEEVE	1	
29#	EM934045	ADJUSTING RING	1	
30#	EM963289	BOLT	2	
31#	EM969009	LOCK NUT	2	
32#	EM934044	RELEASE BEARING ASSY.	1	
33	1475	WIRE SPLICE	1	
34	EM203149	EXHAUST DEFLECTOR	1	
35*	EM203040	SLEEVE	1	
36	EM801570	PILOT BUSHING	1	
37	EM934022	CLUTCH ASM	1 INCLUDES ITEMS/W#
38*	13377	OIL SEAL	4	
39*	13379	COPPER WASHER	4	

EM-120SM — ELECTRIC MOTOR ASSY.

ELECTRIC MOTOR ASSY.

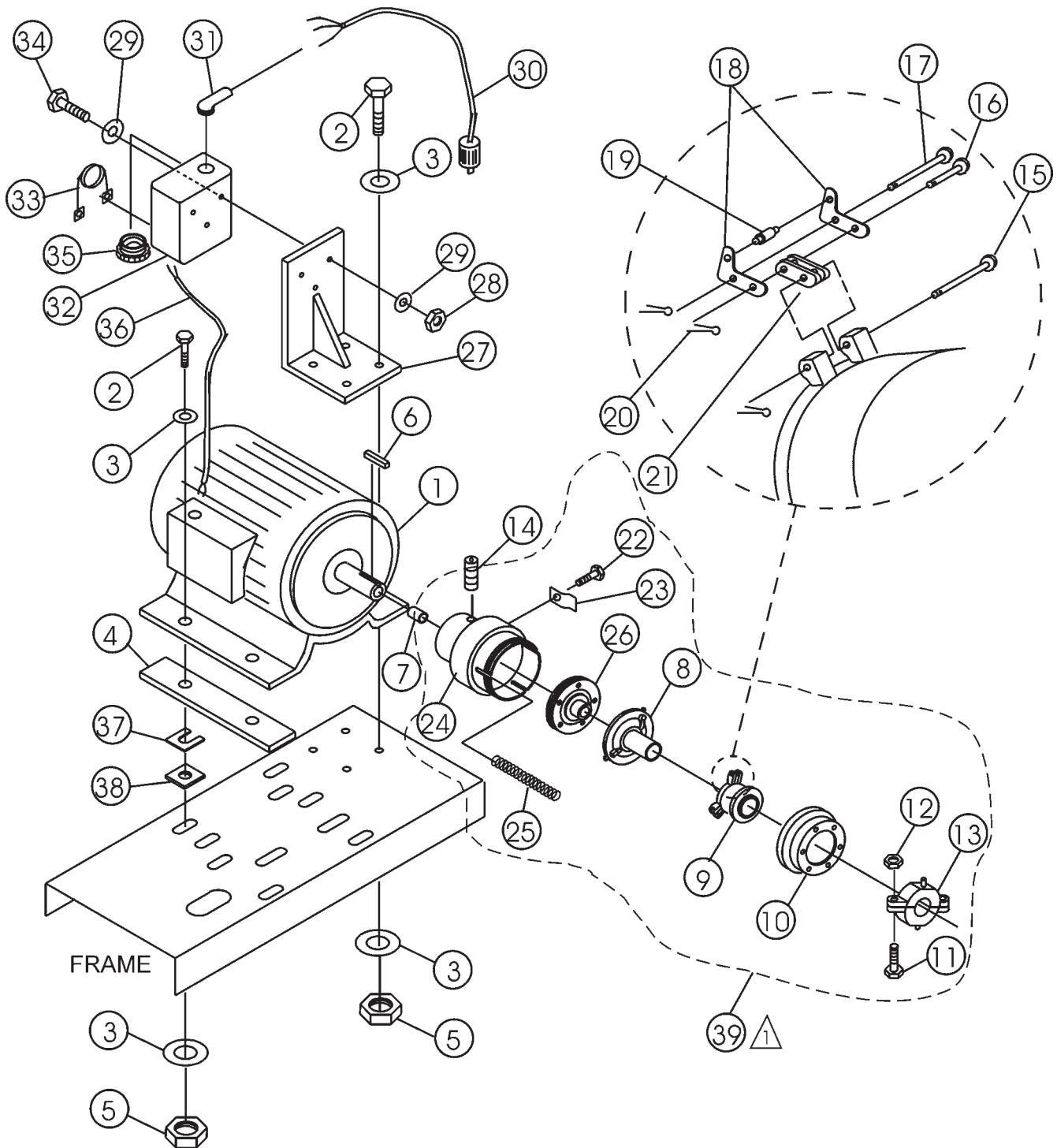

NOTES:

△ COMPLETE CLUTCH ASSEMBLY, ITEM 39, P/N 934022 INCLUDES ALL ITEMS WITHIN OUTLINE.

EM-120SM — ELECTRIC MOTOR ASSY.

ELECTRIC MOTOR ASSY.

<u>NO</u>	<u>PART NO</u>	<u>PART NAME</u>	<u>QTY.</u>	<u>REMARKS</u>
1	EM939228	5 HP 1 PHASE ELECT. MOTOR	1	
1	EM239229	5 HP 3 PHASE ELECT. MOTOR	1	
1?	EM939229	5 HP 3 PHASE ELECT. MOTOR	1	
2	1023	HHCS 3/8-16 x 1.1/4"	8	
3	10136	FLAT WASHER 3/8"	16	
4	EM204549	MOTOR MOUNT	2	
5	10133	LOCK NUT 3/8-16	8	
6	EM010009	SQ KEY	1	
7	EM801570	BUSHING	1	
8	EM934042	PRESSURE PLATE ASSY.	1	
9	EM934043	RELEASE SLEEVE	1	
10#	EM934045	ADJUSTING RING	1	
11#	EM963289	BOLT	2	
12#	EM969009	LOCK NUT	2	
13#	EM934044	RELEASE BEARING ASSY.	1	
14#	EM961045	SHSS 5/16-18 x 1/2" NYLOC	1	
15#	EM925013	LEVER PIN	3	
16#	EM925018	SHORT LINK PIN	3	
17#	EM925016	LONG LINK PIN	3	
18#	EM959012	LEVER	6	
19#	EM934054	ROLLER	3	
20#	5117	COTTER PIN	9	
21#	EM934053	CONNECTING LINK	6	
22	9503	SLOTTED HHCS 1/4-20 x 1/2"	1	
23#	EM934040	ADJUSTING LOCK	1	
24#	EM934039	CLUTCH HOUSING	1	
25#	EM918009	SPRING	3	
26#	EM934041	SPLINED CENTER W/FACING	1	
27	EM204526	MOUNT BRKT.	1	
28	10019	LOCK NUT 10-32	3	
29	2203	FLAT WASHER #10	6	
30	EM201794	PIG TAIL	1	
31	0174	90 DEG ELBOW	1	
32	EM98187	MOTOR STARTER 1 PHASE	1	
32	EM98191	MOTOR STARTER 3 PHASE	1	
33	EM940198	HEATER 1 PHASE	1	
33	EM940198	HEATER 3 PHASE	1	
34	8133	RHMS 10-32 x 3/4"	3	
35	EM940184	REDUCER BUSHING	1	
36	EM012295	CONDUIT	1	
37	EM100235	ENGINE SHIM .030	AR	
	EM100236	ENGINE SHIM .018	AR	
	EM100237	ENGINE SHIM .010	AR	
38	EM203007	ENGINE PAD .187	AR	
	EM203016	ENGINE PAD .135	AR	
	EM203017	ENGINE PAD .060	AR	
39	EM934022	CLUTCH ASSY.	1	INCLUDES ITEMS/W#

EM-120SM — TRANSMISSION ASSY.

TRANSMISSION ASSY.

<u>NO</u>	<u>PART NO</u>	<u>PART NAME</u>	<u>QTY.</u>	<u>REMARKS</u>
1#	2200	HHCS 3/8-24 x 2"	1	
2#	EM600029	SHIFTER SHAFT	1	
3#	EM914005	SEAL	1	
4#	EM600028	CLUTCH YOKE	1	
5#	0181B	LOCK WASHER 1/4"	2	
6#	0730	HHCS 1/4-20 x 1"	2	
7#	EM926029	SNAP RING	2	
8#	EM600023	BEARING RETAINER	1	
9#	EM600022	BEARING RETAINER GASKET	1	
10#	914209	SEAL	1	
11#	EM902091	BALL BEARING	4	
12#	EM600016	INPUT PINION SHAFT	1	
13#	EM911329	SQ HEAD MAG. PIPE PLUG 3/8"	2	
14#	EM600020	INTERNAL GEAR	1	
15#	EM010062	SQ KEY 3/8 x 3/8 x 1.3/8"	1	
16#	EM600131	OUTPUT DRIVE PINION	1	
17#	10136	FLAT WASHER 3/8"	1	
18#	EM902161	BALL BEARING	1	
19	EM963157	HHCS 5/8-11 x 4.1/2" GD2	1	
20	EM961019	SQHSS 3/8-16 x 1.1/4" CUP	2	
21	EM200255	PADDLE SHAFT COUPLER	1	
22	EM010022	SQ KEY 3/8 x 3/8 x 1.3/4"	1	
23	9503	LOCK NUT 5/8-11	1	
24#	EM600015	OUTPUT SHAFT	1	
25#	EM914207	OIL SEAL	1	
26#	EM600014	TRANSMISSION COVER	1	
27#	1729	ROLL PIN	1	
28#	EM926036	SNAP RING	1	
29#	EM911064	SQ HEAD PIPE PLUG 1/2 NPT	2	
30#	EM600012	MAIN TRANSMISSION HOUSING	1	
31#	EM911356	BREATHER VENT PIPE PLUG 1/2"	2	
32#	EM600133	OUTPUT SHAFT GEAR	1	
33#	EM600024	LOCK PLATE	1	
34#	EM927048	WOODRUFF KEY #A	1	
35#	10133	LOCK NUT 3/8-16	1	
36#	EM600021	TRANSMISSION COVER GASKET	1	
37	EM600018	SHIFTER LEVER	1	
38#	0161C	LOCK WASHER 3/8"	17	
39#	0202	HHCS 5/8-16 x 1"	17	
40#	4196	HHCS 3/8-16 x 3/4"	6	
41#	1875	INTER. SHKP WASHER 3/8"	6	
42#	EM931233	SHIFTER COVER	1	
43#	EM600026	SHIFTER COVER GASKET	1	
44#	EM300999	STUD 7 / 16-14 x 2.1/16"	4	
45#	2955	LOCK WASHER 7/16"	4	
46#	EM968010	HEX NUT 7/16-14	4	
47#	EM925109	DOWEL PIN	3	
48	EM801965	GASKET	1	
49	EM600000	COMP. TRANSMISSION ASSY.	1	INCLUDES ITEMS/W#

TERMS AND CONDITIONS OF SALE — PARTS

PAYMENT TERMS

Terms of payment for parts are net 10 days.

FREIGHT POLICY

All parts orders will be shipped collect or prepaid with the charges added to the invoice. All shipments are F.O.B. point of origin. Multiquip's responsibility ceases when a signed manifest has been obtained from the carrier, and any claim for shortage or damage must be settled between the consignee and the carrier.

MINIMUM ORDER

The minimum charge for orders from Multiquip is \$15.00 net. Customers will be asked for instructions regarding handling of orders not meeting this requirement. If possible, additional fast moving parts will be added to the order to total \$15.00 minimum.

RETURNED GOODS POLICY

Return shipments will be accepted and credit will be allowed, subject to the following provisions:

1. A Returned Material Authorization must be approved by Multiquip prior to shipment. A copy of the Authorization must accompany the shipment to the designated Warehouse. A copy of the original Multiquip invoice to the customer must also accompany the shipment.
2. Parts being returned must be listed as currently supplied on the current parts list.

3. Parts must be in new and resalable condition, in the original Multiquip package, with Multiquip part numbers clearly marked.
4. Any item with a list price of \$1.00 or less will not be accepted.
5. Any parts with a limited shelf life (such as gaskets, seals, "O" rings, filters, etc.) that are over six months old will not be accepted.
6. Special order items are not returnable for credit.
7. Engine parts other than 2-cycle engine parts will not be accepted.
8. Credit on returned parts will be issued at dealer net price at time of original purchase, less a 15% restocking charge.
9. Credit issued will be applied to future purchases only.
10. All parts must be returned freight prepaid to Multiquip's designated receiving point. Freight is at the sender's expense.

The sender will be notified of any material received not meeting the above provisions. Such material will be held for 30 days from notification, pending instructions. If a reply is not received within 30 days, the material will be returned to the seller at his expense.

PRICING AND REBATES

Prices are subject to change without prior notice.

Price changes are effective on a specific date and all shipments on or after that date will be billed at the revised price.

Rebates for price declines and added charges for price increases will not be made for stock on hand at the time of any price change.

Multiquip reserves the right to quote and sell direct to Government agencies, and to Original Equipment Manufacturer accounts who use our products as integral parts of their own products.

SPECIAL EXPEDITING SERVICE

A \$20.00 to \$50.00 surcharge will be added to the invoice for special handling including bus shipments, insured parcel post or in cases where Multiquip must personally deliver the parts to the carrier.

LIMITATION OF SELLER'S LIABILITY

Multiquip shall not be liable hereunder for damages in excess of the purchase price of the item with respect to which damages are claimed, and in no event shall Multiquip be liable for loss of profit or good will or for any other special, consequential or incidental damages.

LIMITATION OF WARRANTIES

No warranties, express or implied, are made in connection with the sale of parts or trade accessories nor as to any engine not manufactured by Multiquip. Such warranties made in connection with the sale of new, complete units are made exclusively by a statement of warranty packaged with such units, and Multiquip neither assumes nor authorizes any person to assume for it any other obligation or liability whatever in connection with the sale of its products. Apart from such written statement of warranty, there are no warranties, express, implied or statutory, which extend beyond the description of the products on the face hereof.

PARTS AND OPERATION MANUAL

HERE'S HOW TO GET HELP

*PLEASE HAVE THE MODEL AND SERIAL NUMBER
ON-HAND WHEN CALLING*

PARTS DEPARTMENT

800-427-1244 or 310-537-3700

FAX: 800-672-7877 or 310-637-3284

SERVICE DEPARTMENT/TECHNICAL ASSISTANCE

800-478-1244 or 310-537-3700

FAX: 310- 537-4259

WARRANTY DEPARTMENT

888-661-4279, or 310-661-4279

FAX: 310- 537-1173

MAIN

800-421-1244 or 310-537-3700

FAX: 310-537-3927



MULTIQUIP INC.

POST OFFICE BOX 6254
CARSON, CA 90749
310-537-3700 • 800-421-1244
FAX: 310-537-3927
E-MAIL: mq@multiquip.com
WWW: multiquip.com

Atlanta • Boise • Dallas • Houston • Newark
Quebec, Canada • Manchester, UK • Rio De Janeiro, BR • Guadalajara, MX