

# OPERATION AND PARTS MANUAL



## JA-SERIES WALK-BEHIND TROWEL

MODEL # \_\_\_\_\_

SERIAL # \_\_\_\_\_

Revision #6 (11/14/05)



**MULTIQUIP INC.**

18910 WILMINGTON AVE.  
CARSON, CALIFORNIA 90746  
310-537-3700  
800-421-1244  
FAX: 310-537-3927

**PARTS DEPARTMENT:**

800-427-1244  
FAX: 800-672-7877  
**SERVICE DEPARTMENT/TECHNICAL ASSISTANCE:**  
800-478-1244  
FAX: 310-631-5032

**E-mail: [mq@multiquip.com](mailto:mq@multiquip.com) • [www.multiquip.com](http://www.multiquip.com)**

Atlanta • Boise • Dallas • Houston • Newark  
Montreal, Canada • Manchester, UK  
Rio De Janiero, Brazil • Guadalajara, Mexico



# WARNING



## **CALIFORNIA — Proposition 65 Warning**

Engine exhaust and some of its constituents, and some dust created by power sanding, sawing, grinding, drilling and other construction activities contains chemicals known to the State of California to cause cancer, birth defects and other reproductive harm. Some examples of these chemicals are:

- Lead from lead-based paints.
- Crystalline silica from bricks.
- Cement and other masonry products.
- Arsenic and chromium from chemically treated lumber.

Your risk from these exposures varies, depending on how often you do this type of work. To reduce your exposure to these chemicals: **ALWAYS** work in a well ventilated area, and work with approved safety equipment, such as dust masks that are specially designed to filter out microscopic particles.

## **HERE'S HOW TO GET HELP**

*PLEASE HAVE THE MODEL AND SERIAL NUMBER  
ON-HAND WHEN CALLING*

### ***PARTS DEPARTMENT***

*800-427-1244 or 310-537-3700*

*FAX: 800-672-7877 or 310-637-3284*

### ***SERVICE DEPARTMENT/TECHNICAL ASSISTANCE***

*800-478-1244 or 310-537-3700*

*FAX: 310- 537-4259*

### ***WARRANTY DEPARTMENT***

*888-661-4279, or 310-661-4279*

*FAX: 310- 537-1173*

### ***MAIN***

*800-421-1244 or 310-537-3700*

*FAX: 310-537-3927*

# JA-SERIES TROWEL— TABLE OF CONTENTS

Here's How To Get Help .....	3
Table Of Contents .....	4
Parts Ordering Procedures .....	5
Training Checklist .....	6
Daily Pre-Operation Checklist .....	7
Safety Message Alert Symbols .....	8-9
Rules For Safe Operation .....	10-11
Operation And Safety Decals .....	12
Specifications (Trowel) .....	13
Specifications (Engines) .....	14
Specifications (Trowel Weights) .....	14
General Information .....	15

## **MQ WHITEMAN — JA-SERIES TROWEL**

Controls and Components .....	16-17
Basic Engine .....	18
Assembly and Installation .....	19-21
Pre-Inspection .....	22-23
Initial Start-Up (Gasoline Engine) .....	24-25
Operation .....	26-27
Options .....	28-29
Maintenance .....	30-34
Troubleshooting (Trowel) .....	35-36
Troubleshooting (Engine) .....	37
Explanation of Codes in Remarks Column .....	38
Suggested Spare Parts .....	39
Nameplate and Decals .....	40-41
Standard Handle Assembly .....	42-43
Quick Pitch™ Handle Assembly .....	44-46
Thrust Bearing Kit Assembly .....	48-49
4-Blade spider Assembly .....	50-51
Gearbox and Engine Mounts Assembly .....	52-54
Engines, Honda, Robin, & Briggs & Stratton .....	56-57
Hand Clutch Assembly .....	58-59
Guard Ring Assembly .....	60-61
Blades and Adjustment Fixture Assembly .....	62-63
Lifting Bale Assembly .....	64-65

## **HONDA GX160K1QA2 ENGINE**

Cylinder Head Assembly .....	66-67
Cylinder Barrel Assembly .....	68-69
Crankcase Cover Assembly .....	70-71
Crankshaft Assembly .....	72-73
Piston Rings Assembly .....	74-75
Camshaft Assembly .....	76-77
Recoil Starter Assembly .....	78-79
Fan Cover Assembly .....	80-81
Carburetor Assembly .....	82-83
Air Cleaner Assembly .....	84-85
Muffler Assembly .....	86-87
Fuel Tank Assembly .....	88-89
Flywheel Assembly .....	90-91
Ignition Coil Assembly .....	92-93
Control Assembly .....	94-95
Label Assembly .....	96-97
Gasket Kit Assembly .....	99

## **ROBIN EH-17 ENGINE**

Crankcase Assembly .....	100-101
Crankshaft Assembly .....	102-103
Intake and Exhaust Assembly .....	104-105
Governor Assembly .....	106-107
Cooling and Starting Assembly .....	108-109
Fuel Tank Assembly .....	110-111
Carburetor Assembly .....	112-113
Recoil Start Assembly .....	114-115
Oil Sensor Assembly .....	116-117

Terms and Conditions of Sale — Parts .....	118
--	-----

### **NOTE**

*Specification and part number  
are subject to change without  
notice.*

# JA-SERIES TROWEL— PARTS ORDERING PROCEDURES

- Dealer account number
- Dealer name and address
- Shipping address (if different than billing address)
- Return fax number
- Applicable model number
- Quantity, part number and description of each part
- Specify preferred method of shipment:
  - UPS Ground
  - UPS Second Day or Third Day\*
  - UPS Next Day\*
  - Federal Express Priority One (please provide us with your Federal Express account number)\*
  - Airborne Express\*
  - Truck or parcel post

*\*Normally shipped the same day the order is received, if prior to 2PM west coast time.*

## Earn Extra Discounts when you order by FAX!

All parts orders which include complete part numbers and are received by fax qualify for the following extra discounts:

<u>Number of line items ordered</u>	<u>Additional Discount</u>
1-9 items	3%
10+ items**	5%

### Get special freight allowances when you order 10 or more line items via FAX!\*\*

- UPS Ground Service at no charge for freight
- UPS Third Day Service at one-half of actual freight cost

No other allowances on freight shipped by any other carrier.

\*\*Common nuts, bolts and washers (all items under \$1.00 list price) do not count towards the 10+ line items.

\*DISCOUNTS ARE SUBJECT TO CHANGE\*

Fax order discount and UPS special programs revised June 1, 1995

**Extra Fax Discount  
for Domestic USA  
Dealers Only**

**Up to 5%  
extra savings!**

**UPS  
Special**  
For faxed orders only

**Now! Direct TOLL-FREE access  
to our Parts Department!**

Toll-free nationwide:

800-421-1244

Toll-free FAX:

800/6-PARTS-7 • 800-672-7877

# JA-SERIES TROWEL— TRAINING CHECKLIST

## TRAINING CHECKLIST

This checklist will lists some of the minimum requirements for machine maintenance and operation. Please feel free to detach it and make copies. Use this checklist whenever a new operator is to be trained or it can be used as a review for more experienced operator's.

TRAINING CHECKLIST			
NO.	DESCRIPTION	OK?	DATE
1	Read Operator's Manual completely.		
2	Machine layout, location of components, checking of engine and gearbox fluid level.		
3	Fuel system, refueling procedure		
4	Operation of controls (machine not running).		
5	Safety controls, kill switch operation.		
6	Emergency stop procedures.		
7	Startup of machine.		
8	Maneuvering		
9	Pitching		
10	Concrete finishing techniques.		
11	Shutdown of machine.		
12	Lifting of machine (optional equipment).		
13	Machine transport and storage.		

Operator \_\_\_\_\_ Trainee \_\_\_\_\_

COMMENTS:

# JA-SERIES TROWEL— DAILY PRE-OPERATION CHECKLIST

## DAILY PRE-OPERATION CHECKLIST

DAILY PRE-OPERATION CHECKLIST	
1	Engine Oil Level.
2	Gearbox Fluid Level.
3	Condition of Blades.
4	Blade Pitch Operation.
5	Safety Kill Switch Operation.
6	Clutch Operation

COMMENTS:

# JA-SERIES TROWEL— SAFETY MESSAGE ALERT SYMBOLS

## FOR YOUR SAFETY AND THE SAFETY OF OTHERS!

Safety precautions should be followed at all times when operating this equipment. Failure to read and understand the Safety Messages and Operating Instructions could result in injury to yourself and others.

### NOTE

This Owner's Manual has been developed to provide complete instructions for the safe and efficient operation of the MQ Whiteman JA-SERIES TROWEL. For engine maintenance information, please refer to the engine manufacturers instructions for data relative to its safe operation.

**Before using this WALK-BEHIND TROWEL, ensure that the operating individual has read and understands all instructions in this manual.**

## SAFETY MESSAGE ALERT SYMBOLS

The three (3) Safety Messages shown below will inform you about potential hazards that could injure you or others. The Safety Messages specifically address the level of exposure to the operator, and are preceded by one of three words: **DANGER**, **WARNING**, or **CAUTION**.



**DANGER:** You **WILL** be **KILLED** or **SERIOUSLY** injured if you **DO NOT** follow directions.



**WARNING:** You **CAN** be **KILLED** or **SERIOUSLY** injured if you **DO NOT** follow directions.



**CAUTION:** You **CAN** be injured if you **DO NOT** follow directions.

Potential hazards associated with JA-Series trowel operation will be referenced with "**Hazard Symbols**" which appear throughout this manual, and will be referenced in conjunction with Safety "**Message Alert Symbols**".

## HAZARD SYMBOLS



### Lethal Exhaust Gases



Engine exhaust gases contain poisonous carbon monoxide. This gas is colorless and odorless, and can cause death if inhaled. **NEVER** operate this equipment in a confined area or enclosed structure that does not provide ample free flow air.



### Explosive Fuel



Gasoline is extremely flammable, and its vapors can cause an explosion if ignited. **DO NOT** start the engine near spilled fuel or combustible fluids. **DO NOT** fill the fuel tank while the engine is running or hot. **DO NOT** overfill tank, since spilled fuel could ignite if it comes into contact with hot engine parts or sparks from the ignition system. Store fuel in approved containers, in well-ventilated areas and away from sparks and flames. **NEVER** use fuel as a cleaning agent.



### Burn Hazards



Engine components can generate extreme heat. To prevent burns, **DO NOT** touch these areas while the engine is running or immediately after operations. **NEVER** operate the engine with heat shields or heat guards removed.



### Rotating Parts



**NEVER** operate equipment with covers, or guards removed. Keep fingers, **hands**, **hair** and **clothing** away from all moving parts to prevent injury.

# JA-SERIES TROWEL— SAFETY MESSAGE ALERT SYMBOLS



## Accidental Starting



**OFF** **ALWAYS** place the engine ON/OFF switch in the **OFF** position, when the trowel is not in use.



## Respiratory Hazard



**ALWAYS** wear approved respiratory protection.



## Over Speed Conditions



**NEVER** tamper with the factory settings of the engine governor or settings. Personal injury and damage to the engine or equipment can result if operating in speed ranges above maximum allowable.



## Sight and Hearing hazard

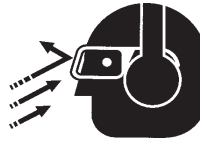

**ALWAYS** wear approved eye and hearing protection.

### NOTE

This *walk-behind trowel*, other property, or the surrounding environment could be damaged if you do not follow instructions.



## Equipment Damage Messages

Other important messages are provided throughout this manual to help prevent damage to your trowel, other property, or the surrounding environment.

# JA-SERIES TROWEL— RULES FOR SAFE OPERATION

## CAUTION:



Failure to follow instructions in this manual may lead to serious injury or even death! This equipment is to be operated by trained and qualified personnel only! This equipment is for industrial use only.

The following safety guidelines should always be used when operating the JA-Series walk-behind trowel.

## SAFETY

- **DO NOT** operate or service this equipment before reading this entire manual.



- This equipment should not be operated by persons under 18 years of age.
- **NEVER** operate the trowel without proper protective clothing, shatterproof glasses, steel-toed boots and other protective devices required by the job.



- **NEVER** operate this equipment when not feeling well due to fatigue, illness or taking medicine.



- **NEVER** operate the trowel under the influence of drugs or alcohol.



- **NEVER** use accessories or attachments, which are not recommended by Multiquip for this equipment. Damage to the equipment and/or injury to user may result.
- Manufacture does not assume responsibility for any accident due to equipment modifications.
- Whenever necessary, replace nameplate, operation and safety decals when they become difficult read.
- **ALWAYS** check the trowel for loosened threads or bolts before starting.

- **NEVER** touch the hot exhaust manifold, muffler or cylinder. Allow these parts to cool before servicing the trowel.

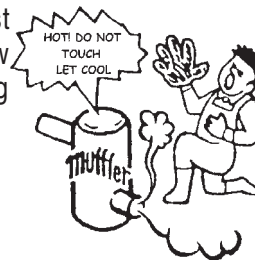

- **High Temperatures** – Allow the engine to cool before adding fuel or performing service and maintenance functions. Contact with **hot!** components can cause serious burns.

- The engine of this trowel requires an adequate free flow of cooling air. **NEVER** operate the trowel (except electric models) in any enclosed or narrow area where free flow of the air is restricted. If the air flow is restricted it will cause serious damage to the trowel's engine and may cause injury to people. Remember the trowel's engine gives off **DEADLY** carbon monoxide gas.

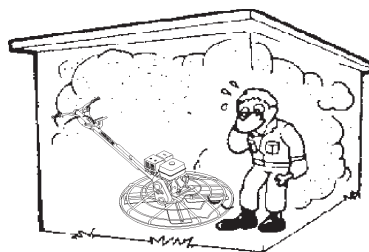

- **ALWAYS** refuel in a well-ventilated area, away from sparks and open flames.

- **ALWAYS** use extreme caution when working with **flammable** liquids. When refueling, **stop the engine** and allow it to cool.

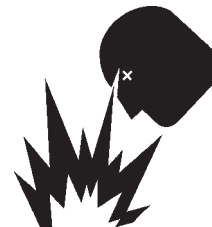

- **NEVER** smoke around or near the machine. Fire or explosion could result from **fuel vapors**, or if fuel is spilled on a **hot!** engine.



- **NEVER** operate the trowel in an explosive atmosphere or near combustible materials. An explosion or fire could result causing severe **bodily harm or even death**.

- Topping-off to filler port is dangerous, as it tends to spill fuel.

# JA-SERIES TROWEL— RULES FOR SAFE OPERATION

- **DO NOT** operate this trowel unless all guards and safety devices are attached and in place. See Pages 16 and 17.
- **ALWAYS** use proper lifting techniques when moving the trowel.
- **ALWAYS** check to make sure that the operating area is clear before starting the engine.
- **ALWAYS** test the safety *kill switch* devices before operating the trowel.
- **NEVER** place your *feet* or *hands* inside the guard rings while starting or operating this equipment.
- **AVOID** wearing jewelry or loose fitting clothing that may snag on the controls or moving parts, this can cause a serious injury.
- **ALWAYS** keep clear of *rotating* or *moving parts* while operating the trowel.
- **NEVER** leave the machine *unattended* while running.
- **Moving Parts** – Shut down the engine before performing service or maintenance functions. Contact with moving parts can cause serious injury.
- Keep the trowel in proper running condition.
- Make sure that there is no buildup of concrete, grease, oil or debris on the trowel.
- Fix damage to the trowel immediately and always replace broken parts.
- Dispose of hazardous waste properly. Examples of potentially hazardous waste are used *motor oil*, *fuel* and *fuel filters*.
- **High Temperatures** – Allow the machine and engine to *cool* before adding fuel or performing service and maintenance functions. Contact with *hot!* components can cause serious burns.

## CAUTION

### Emergencies



- **ALWAYS** know the location of the nearest *fire extinguisher* and *first aid kit*. Know the location of the nearest telephone. Also know the phone numbers of the nearest *ambulance*, *doctor* and *fire department*. This information will be invaluable in the case of an *emergency*.

### Maintenance Safety

- Disconnect the spark plug wires before attempting any type of service.
- Securely support any machine components that must be raised.
- **NEVER** lubricate components or attempt service on a running machine.
- **DO NOT** use food or plastic containers to dispose of hazardous waste.
- **DO NOT** pour *waste*, *oil* or *fuel* directly onto the ground, down a drain or into any water source.

# JA-SERIES TROWEL— OPERATION AND SAFETY DECALS

## Machine Safety Decals

The JA-Series walk-behind trowel is equipped with a number of safety decals. These decals are provided for operator safety and maintenance information. Figure 1 below illustrates these decals as they appear on the machine. Should any of these decals become unreadable, replacements can be obtained from your dealer.

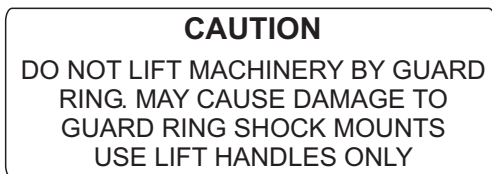

P/N 1261



P/N 20526



P/N 1940



P/N 20527



P/N 1736

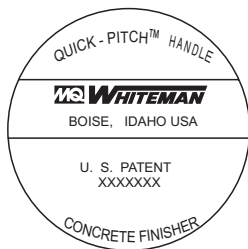

P/N 1758



P/N 12405



P/N 1492



P/N 1848



P/N 1735



P/N 2938



P/N1499

	Symbol indicates that it is mandatory to wear safety glasses, safety helmet and ear protection. <b>P/N 11247</b> (Part of decal kit 12620)		CONTACT MULTIQUIP SERVICE DEPT.
	Symbol indicates that it is mandatory to wear gloves. <b>P/N 11247</b> (Part of decal kit 12620)		Symbol indicates that it is mandatory to wear safety shoes, with extra protection (steel toed). <b>P/N 11247</b> (Part of decal kit 12620)
	Radiating heat symbol. Symbol indicates equipment is hot. <b>P/N 11246</b> (Part of decal kit 12620)		This is the symbol for belt drive. <b>P/N 11246</b> (Part of decal kit 12620)
	Symbol for examining or checking of the machine. Mostly used for maintenance. Check lubrication oil in gearbox. <b>P/N 11246</b> (Part of decal kit 12620)		This is the symbol for gear drive. <b>P/N 11246</b> (Part of decal kit 12620)

Figure 1. JA-Series Trowel Decals

# JA-SERIES TROWEL— SPECIFICATIONS (TROWEL)

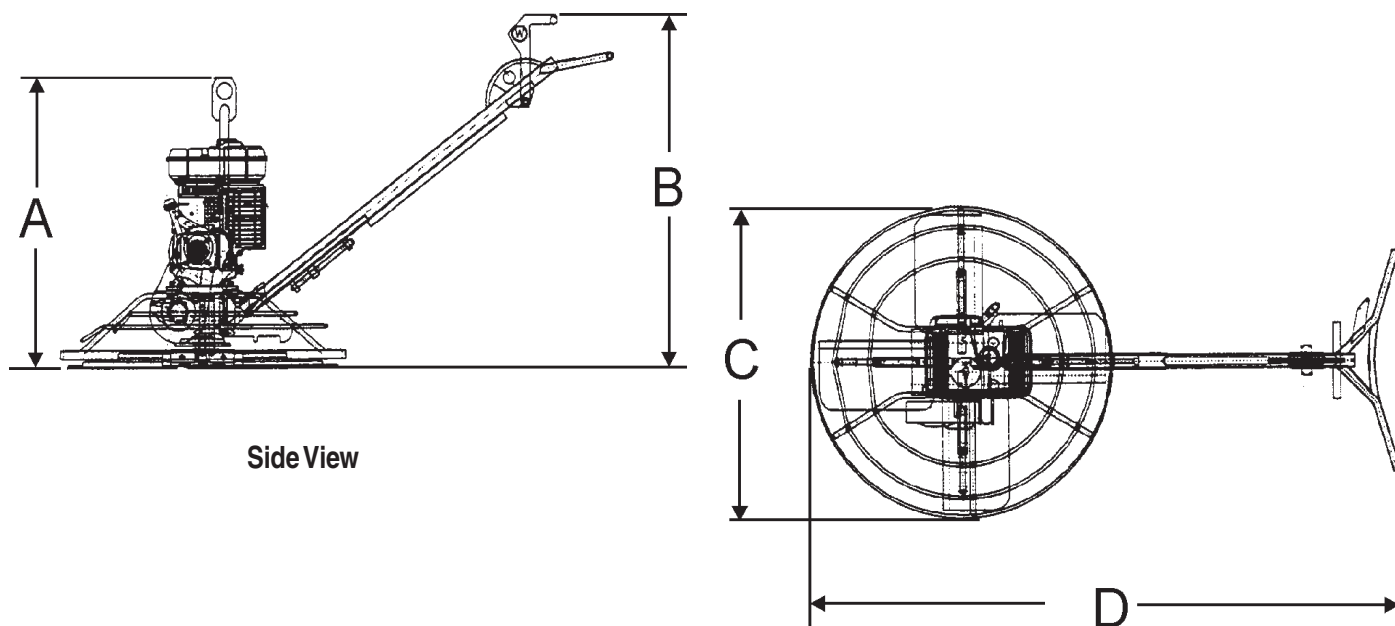

Figure 2. JA-Series Trowel Dimensions

Table 1. JA-Series Trowel Specifications	
A- Height (Lifting Hook)	36.7 in (931.6 mm)
B- Height Engagement Lever)	41.4 in (1,044.2 mm)
C-Width	36.5 (927.1 mm)
D-Length	70.5 (1,789.4 mm)
Weight – Operating	see Table 3.
Sound Pressure	94 db
Vibration	2.0g (19.6 m/s <sup>2</sup> )
Ring Diameter	36.5 in (92.7 cm)
Number of Blades	3 or 4
Blade Tip Speed – FPM (m/s)	1,182 fpm (6.0 m/s)
Rotor – RPM (max.)	129 rpm @ 4000

**NOTE:**

1. Sound pressure is a weighted measure. Measured at the operators ear position while the walk-behind trowel is operating at full throttle on concrete in a manner most often experienced in “*normal*” circumstances. Sound pressure may vary depending upon the condition of the concrete. Hearing protection is always recommended.
2. The vibration level indicated is the maximum RMS (Root Mean Square) value obtained at the handle grip while operating the walk-behind trowel on curing concrete in a manner most often experienced in “*normal*” circumstances. Values were obtained from all three axes of motion. The values shown represent the maximum RMS value from these measurements.

# JA-SERIES TROWEL— SPECIFICATIONS (ENGINES)

**Table 2. Specifications (Engines)**

	Model	HONDA GX160K1QA2	ROBIN EH17-2	BRIGGS & STRATTON INTEK I/C 1114000
Engine	Type	Air-cooled 4 stroke, Single Cylinder, OHV, Horizontal Shaft Gasoline Engine	Air-cooled 4 stroke, Single Cylinder, OHV, Horizontal Shaft Gasoline Engine	Air-cooled 4 stroke, Single Cylinder, OHV, Horizontal Shaft Gasoline Engine
	Bore X Stroke	2.7 in. X 1.8 in. (68 mm x 45 mm)	2.64 in. x 1.93 in. (67 mm x 49 mm)	2.69 in. x 2.04 in. (68.3 mm x 51.8 mm)
	Displacement	9.9 cu. in. (163 cc)	10.50 cu. in. (172 cc)	11.57 cu. in. (190 cc)
	Max Output	5.5 H.P./4000 rpm	6.0 H.P./4000 rpm	5.5 H.P./4000 R.P.M
	Fuel Tank Capacity	0.95 U.S. Gallons (3.6 Liters)	0.95 U.S. Gallons (3.6 Liters)	0.75 U.S. Gallons (2.84 Liters)
	Fuel	Unleaded Automobile Gasoline	Unleaded Automobile Gasoline	Unleaded Automobile Gasoline
	Lube Oil Capacity	0.63 qt. (0.6 liter)	0.68 qt. (0.65 liter)	0.63 qt. (0.6 liter)
	Speed Control Method	Centrifugal Fly-weight Type	Centrifugal Fly-weight Type	Centrifugal Fly-weight Type
	Starting Method	Recoil Start	Recoil Start	Recoil Start
Dimension (L x W x H)	12.3 x 14.3 X 13.2 in. (312 X 362 X 335 mm)	12.09 x 13.98 X 14.96 in. (307 X 355 X 380 mm)	15.56 x 10.01 X 15.19 in. (395 X 254 X 386 mm)	
Dry Net Weight	40.8 lbs (15.0 Kg.)	35.3 lbs (16 Kg.)	31.25 lbs (14.17 Kg.)	

**Table 3. Specifications (Trowel Weights)**

MODEL	POWER SOURCE	OPERATING WEIGHT	SHIPPING WEIGHT
JA-45-H	5.5 HP Honda	154 lbs. (70 kg.)	194 lbs. (88 kg.)
JA-45-BS	5.5 HP Briggs and Stratton	145 lbs. (65.8 kg.)	187 lbs. (84.8 kg.)
JA-46-R	6 HP Robin	151 lbs. (68.5 kg.)	192 lbs. (87 kg.)
JA-46-RM	6 HP Robin, Manual Clutch	151 lbs. (68.5 kg.)	192 lbs. (87 kg.)
JA-45-HM	5.5 HP Honda, Manual Clutch	154 lbs. (70 kg.)	194 lbs. (88 kg.)

# JA-SERIES TROWEL— GENERAL INFORMATION

## JA-Series Walk-Behind Trowel Familiarization

This walk-behind trowel is designed for the **floating** and **finishing** of concrete slabs.

Take a walk around the trowel. Take notice of all the major components (see Figure 3, pages 16 and 17) like the engine, blades, quick pitch control, air cleaner, centrifugal stop switch etc. Check that there is always oil in the engine.

**Read** all the safety instructions carefully. Safety instructions will be found throughout this manual and on the trowel. Keep all safety information in good, readable condition. Operators should be well trained on the operation and maintenance of the trowel.

Before using your trowel, test it on a flat watered down section of finished concrete that is free of any debris and other objects.

This trial test run will increase your confidence in using the trowel and at the same time it will familiarize you with the trowel's controls. In addition you will understand how the trowel handles under actual conditions.

## Engines

This trowel is available with either an 5.5 HP **HONDA**, 6 HP **ROBIN**, or a 5.5 HP **Briggs and Stratton** gasoline engine. Refer to the engine owner's manual for instructions regarding the operation and maintenance of your engine. The engine manual is included with your trowel at the time of shipping from Whiteman. Please contact your nearest Multiquip Dealer for a replacement should the original manual disappear or become unusable.

## Drive System

Power is transferred from the engine or electric motor to the gearbox input shaft via a V-belt or pulley drive system. The pulley engages using either a centrifugal or manual clutch. See page 23.

## Gearbox

The **gearbox** is located beneath the engine and transfers power to the **rotor** or **spider** assembly. The gearbox controls the rotational speed of the trowel and is equipped with two shafts (input and output).

## Spider

The vertical output shaft of the gearbox connects to a cast hub called the **spider**. The spider has either 3 or 4 arms that extend outward that are used for attachment of blades or other accessories. Remember as the gearbox output shaft rotates so does the spider assembly.

## Blades

The blades of the trowel finish the concrete as they are rotated around the surface. Blades are classified as **combination** (8 inches wide), **float** (10 or 8 inches wide), and **finish** (6 inches wide). This trowel comes equipped with either **three** or four **blades** per rotor equally spaced in a radial pattern and attached to vertical rotating shaft by means of a **spider assembly**.

## Centrifugal Stop Switch

In the event of a trowel runaway condition (operator releases the handle), a **centrifugal stop switch**, or **manual clutch** depending which trowel you have, will stop the engine and bring the trowel to a halt.

## CAUTION



**NEVER** attempt to **lift** the trowel by yourself. **ALWAYS** get the assistance of another person to help lift the trowel or use a crane or lifting device to move the trowel.

## Moving the JA-Series Walk-Behind Trowel

This walk-behind trowel is designed to be moved and handled in several ways. The easiest way to lift the trowel is to use the **auxiliary lifting tube** that is attached to the main handle. See page 24, Figure 21. When using the auxiliary tube, always use **two persons** to lift the trowel.

Some models have a **lifting bale** (option) installed. A strap or chain can be attached to the lifting bale, allowing a forklift or crane to lift the trowel up onto a slab of concrete. Use a lifting device of adequate lifting capacity to lift the trowel.

## Training

For proper training, please use the "**TRAINING CHECKLIST**" located in the front of this manual (Page 6). This checklist will provide an outline for an experienced operator to provide training to a new operator.

# JA-SERIES TROWEL— CONTROLS AND COMPONENTS

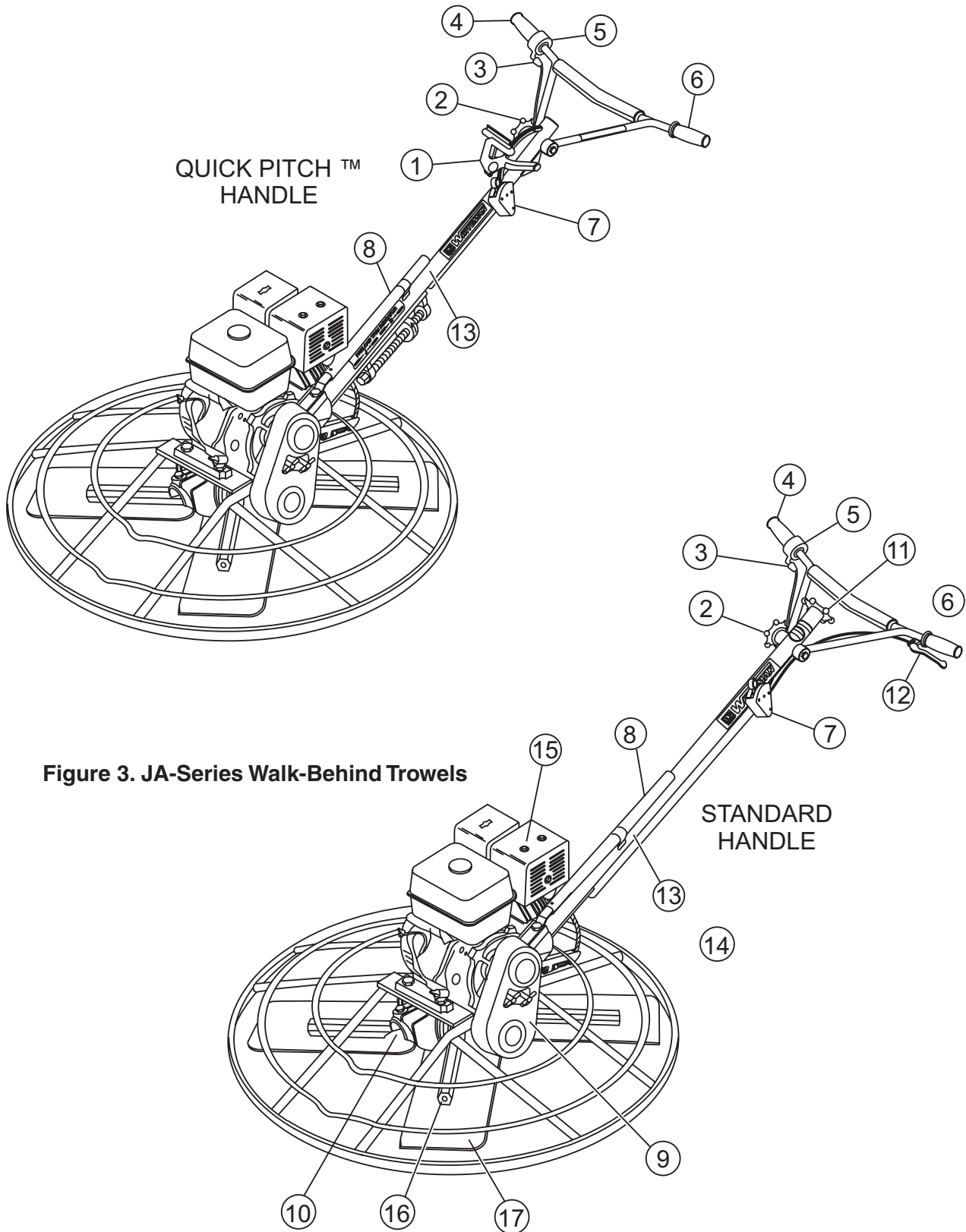

Figure 3. JA-Series Walk-Behind Trowels

## JA-SERIES TROWEL— CONTROLS AND COMPONENTS

Figure 3 shows the location of the Basic controls or components, for the JA-Series trowel. Listed below is a brief explanation of each control or component

1. **Quick Pitch™ Control Handle** – To adjust the pitch of the blades, grasp the handle then squeeze and either move the handle forward or backward to achieve the desired blade pitch.
2. **Handlebar Adjuster** – Change the angle/height of the handle bars by loosening star wheel, adjust handlebars to desired location, tighten starwheel firmly to hold handlebars in that position.
3. **Hand Grip/Handlebar** – When operating the trowel, place both hands on each grip to maneuver the trowel. Replace hand grips when they become worn or damaged.
4. **Throttle Control Grip** – Controls the speed of the engine. Rotate the hand grip away from the operator to increase engine speed (high), toward the operator to decrease engine speed (low).
5. **Throttle** – Controls engine speed when throttle control grip is rotated.
6. **Hand Grip/Handlebar** – When operating the trowel, place both hands on each grip to maneuver the trowel. Replace hand grips when they become worn or damaged.
7. **Centrifugal Kill Switch** – In the event the operator loses control of the trowel, this switch will shut-down the engine.
8. **Auxiliary Lifting Tube** - Use this tube to lift the trowel onto a slab. Tube is to be inserted into socket located in front of the gearbox.
9. **V-Belt Cover** – Remove this cover to gain access to the V-belt. **NEVER** operate the trowel with this cover removed.
10. **Trowel Lifting Point** – Insert the auxiliary lifting tube here. See Figure 21.
11. **Pitch Control (standard models)** - Turn this "Star Wheel" clockwise for increase blade pitch, and counter-clockwise for decrease blade pitch.
12. **Clutch Lever** - Clutch engagement lever. When this lever is engaged, the blades will begin to rotate. May be used with either Quick Pitch™ or Standard handle.
13. **Main Tube** - When disassembling components inside the tube exercise extreme **CAUTION!** Tube is spring-loaded, severe injury could result if not disassembled correctly.
14. **Guard Ring- NEVER** put hands or feet inside guard ring.
15. **Engine** – This trowel uses Honda, Robin and Briggs and Stratton type gasoline engines.
16. **Trowel Arm** – **NEVER** operate the trowel with a bent, broken or out of adjustment trowel arm. If the blades show uneven wear patterns or some blades wear out faster than others, the trowel arm may need to be adjusted. Use the trowel arm adjustment tool P/N 1817 to adjust the trowel arms.
17. **Blades** – This trowel is equipped with combination blades. These blades are versatile and should take care of most troweling needs. In addition float discs can be attached to the trowel arms that will allow the trowel to float on "wet" concrete.

# JA-SERIES TROWEL— JASIC ENGINE

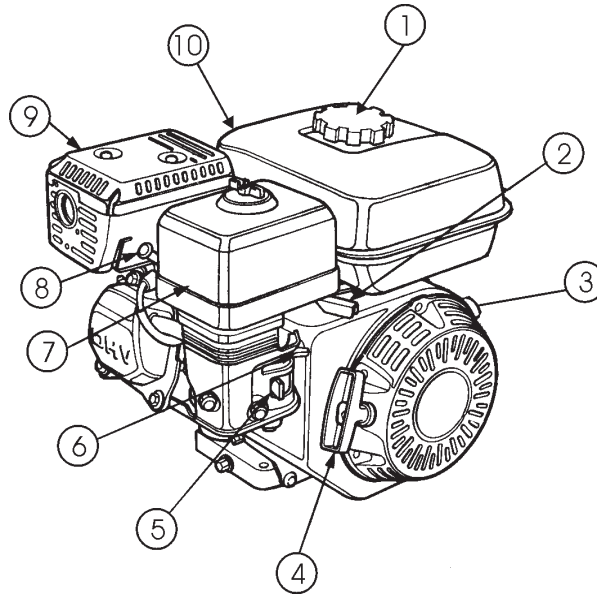

HONDA engine shown.

Figure 4. Engine Controls and Components

## INITIAL SERVICING

The engine (Figure 4) must be checked for proper lubrication and filled with fuel prior to operation. Refer to the manufacturer's engine manual for instructions & details of operation and servicing. The engine shown above is a **HONDA** engine, operation for other types of engines may vary somewhat.

1. **Fuel Filler Cap** – Remove this cap to add unleaded gasoline to the fuel tank. Make sure cap is tightened securely. **DO NOT** over fill.



**! DANGER**

Adding fuel to the tank should be done only when the engine is stopped and has had an opportunity to cool down. In the event of a fuel spill, **DO NOT** attempt to start the engine until the fuel residue has been completely wiped up, and the area surrounding the engine is dry.

2. **Throttle Lever** – Used to adjust engine RPM speed (lever advanced forward **SLOW**, lever back toward operator **FAST**).
3. **Engine ON/OFF Switch** – ON position permits engine starting, OFF position stops engine operations.
4. **Recoil Starter (pull rope)** – Manual-starting method. Pull the starter grip until resistance is felt, then pull briskly and smoothly.

5. **Fuel Valve Lever** – **OPEN** to let fuel flow, **CLOSE** to stop the flow of fuel.
6. **Choke Lever** – Used in the starting of a cold engine, or in cold weather conditions. The choke enriches the fuel mixture.
7. **Air Cleaner** – Prevents dirt and other debris from entering the fuel system. Remove wing-nut on top of air filter canister to gain access to filter element.

### NOTE

Operating the engine without an air filter, with a damaged air filter, or a filter in need of replacement will allow dirt to enter the engine, causing rapid engine wear.

8. **Spark Plug** – Provides spark to the ignition system. Set spark plug gap to 0.6 - 0.7 mm (0.028 - 0.031 inch) Clean spark plug once a week.
9. **Muffler** – Used to reduce noise and emissions.



**! WARNING**

Engine components can generate extreme heat. To prevent burns, **DO NOT** touch these areas while the engine is running or immediately after operating. **NEVER** operate the engine with the muffler removed.

10. **Fuel Tank** – Holds unleaded gasoline. For additional information refer to engine owner's manual.

# JA-SERIES TROWEL — ASSEMBLY AND INSTALLATION

## Assembly and Installation

Before the trowel can be put into operation there are some components that must be installed before the trowel can be used. This section provided general instructions on how to install those components. Instruction sheet P/N 20485 provides further details for the handle assembly.

### Handle Tube Installation (All Models)

1. Install the **handle tube** to the gearbox as shown in (Figure 5). The mounting hardware should be contained in the shipping container.

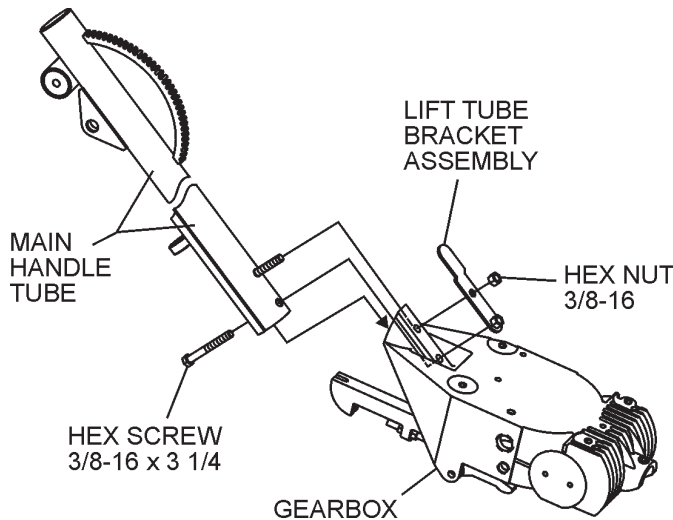

Figure 5. Handle Tube Installation

2. On Quick-Pitch™ models, pivot the **T-handle** back (full pitch) (Figure 6). This will relax the spring inside the handle tube. On either model, spread the handle bar ends just enough to engage the teeth on the handle tube. Attach the hand wheel assembly, position handlebar to desired location, and tighten hand wheel firmly.

## CAUTION



The Quick-Pitch™ handle is spring loaded, personal injury or damage could result from improper handling or installation. Be careful when installing this component.

### NOTE

Considerable force may be required when moving the Quick-Pitch™ **T-handle** forward or backward.

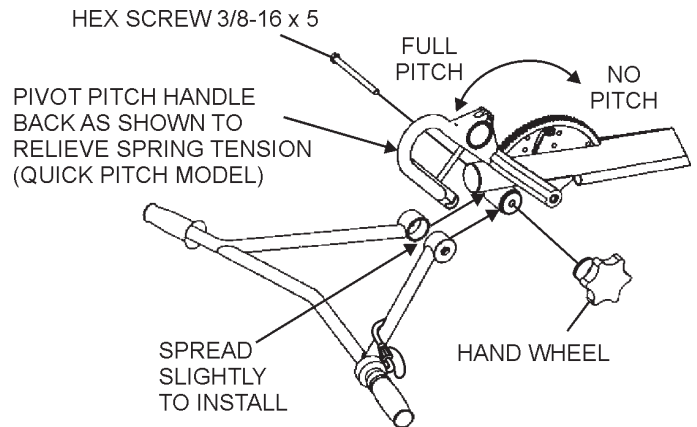

Figure 6. Handlebar Installation

### Throttle Cable Installation (Honda and Robin Engines)

1. Set the **throttle** (Figure 7) to the idle position by rotating the grip toward the operator and away from the engine.

IDLE POSITION - DECREASE THROTTLE

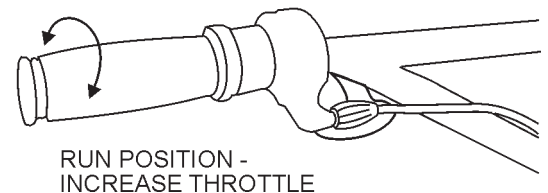

Figure 7. Throttle

2. Feed the throttle cable through the cable housing. Make sure the throttle indicator is on 1".
3. Connect the throttle cable to the engine. (Figure 8), **Honda** and (Figure 9), **Robin**. There should be a piece of wire installed on the trowel to show where to route the throttle cable. When connecting the cable housing, make sure that no more than **1/4" (6.4mm)** of the cable housing protrudes past the housing clamp on the engine.

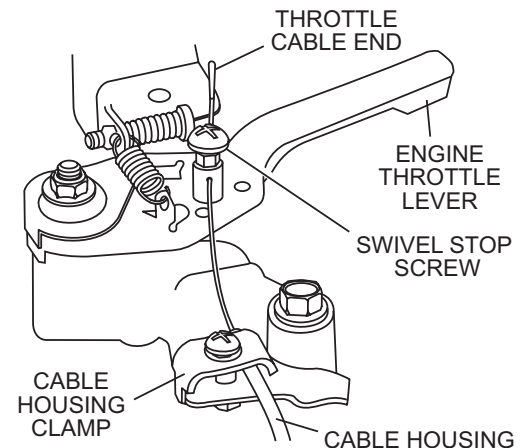
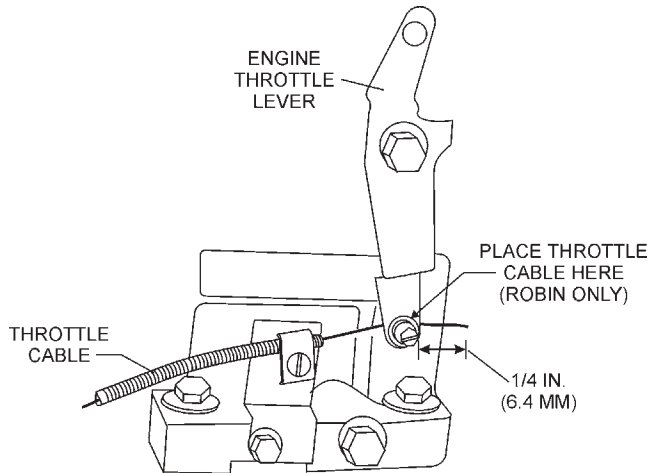

Figure 8. Throttle Cable Connection (HONDA)

# JA-SERIES TROWEL — ASSEMBLY AND INSTALLATION



**Figure 9. Throttle Cable Connection (ROBIN)**

4. Tighten cable clamp screw and swivel stop screw.
5. After the cable has been installed on the engine, adjust and tighten operator position of the handle to lock the throttle cable at the proper length.
6. Adjust cable tension by rotating the barrel adjuster. (Figure 10)

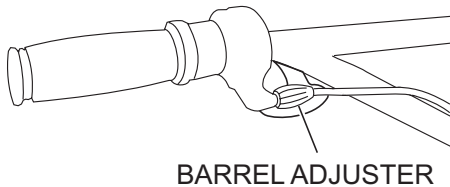

**Figure 10. Barrel Adjuster**

7. These are general instructions. Installation of the throttle cable may vary for different engine configurations. Please look for more detailed instructions inside the box containing the handle. These more detailed instructions should provide adequate guidance for installing.

## Handle Height Adjustment

If handle height adjustment is desired, a handle wedge kit can be purchased for your trowel by ordering P/N 2576 from your Multiquip dealer. These wedges are placed between the handle and the gearbox to adjust the operating height of the handle. This kit comes complete with wedges, new bolts and installation instructions. This will move your operating handle position up or down approximately 3" (76mm).

## Safety Kill Wire

Locate the **RED** wire protruding from the handle tube (Figure 11) and connect it to the **RED** tail wire on the engine. Test the kill switch to insure proper operation.

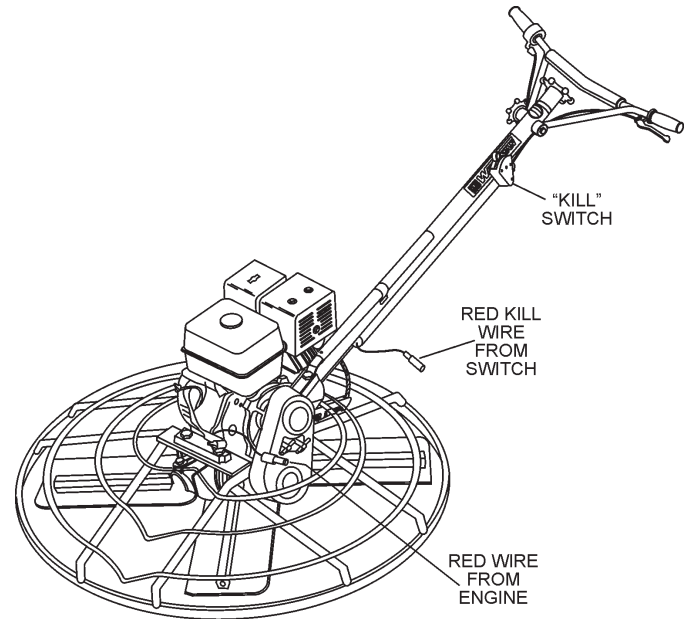

**Figure 11. Engine Kill Wire Connection**

## Pitch Cable Installation

1. Expose the pitch cable to maximum by adjusting the handle pitch to the "no pitch" position. On the standard model turn the pitch control counter-clockwise, (Figure 12). On the Quick-Pitch™ model, pivot the pitch handle forward or no pitch, (Figure 13).

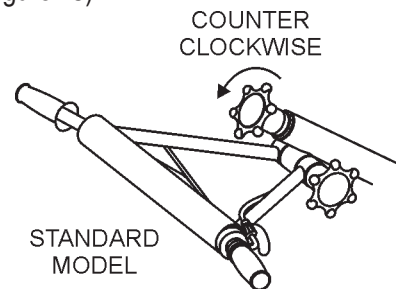

**Figure 12. "No Pitch" Position (Standard)**

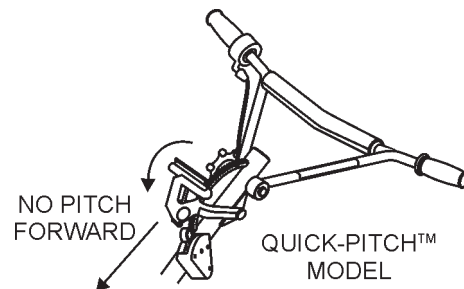

**Figure 13. "No Pitch" Position (Quick-Pitch™)**

# JA-SERIES TROWEL — ASSEMBLY AND INSTALLATION

2. Lock the spring in the compressed position, by releasing the blade pitch adjustment trigger, (Quick-Pitch™ model).
3. Remove one brass set nut from the blade pitch cable end as shown in (Figure 14).
4. Thread the second brass set nut towards the cable as far as possible.

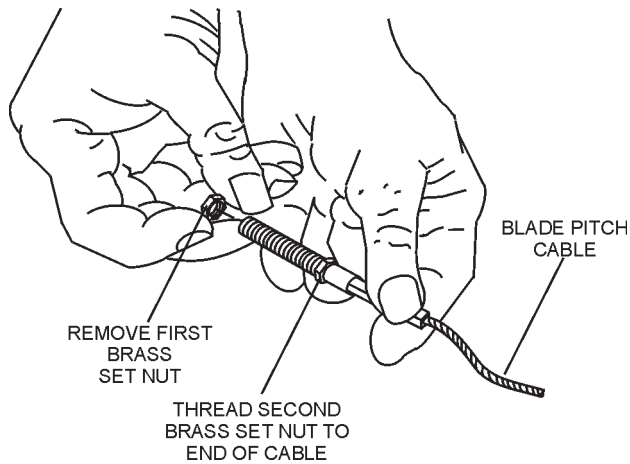

**Figure 14. Blade Pitch Cable**

5. Insert the cable end through the yoke eyelet (Figure 15). Tighten the first brass set nut by hand to remove all the slack from the cable.
6. Using a wrench, tighten the second brass set nut up against the yoke boss. This will lock the cable in place.
7. Use a wrench and finish tightening the first brass set nut up against the yoke boss.

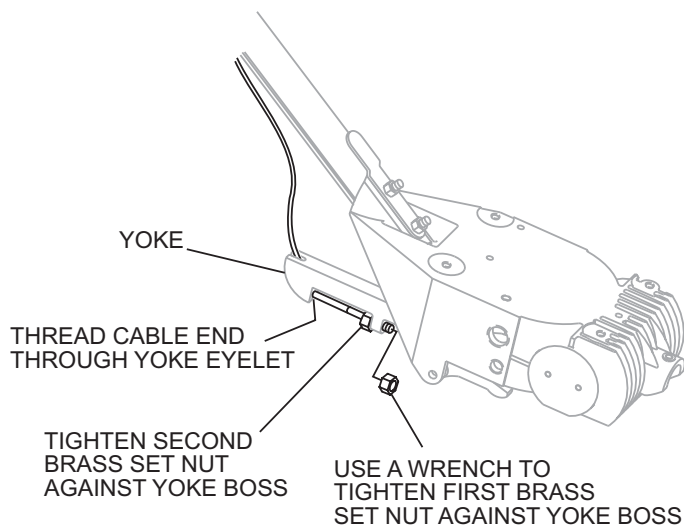

**Figure 15. Cable Yoke Attachment**

## Pre-load Adjustment (Quick-Pitch™ Models Only)

1. After the Quick-Pitch™ handle has been installed on the trowel, spring pre-load adjustment will be required.
2. Locate the adjustment screw on the underside of the handle tube (Figure 16).

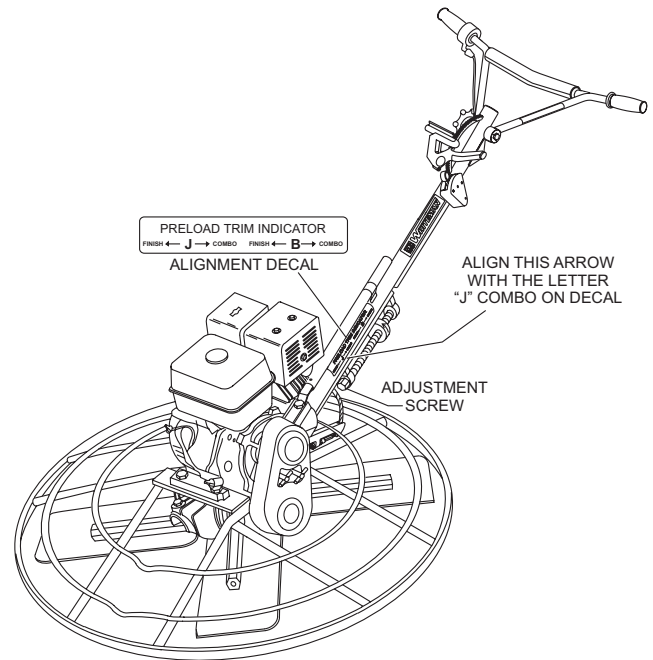

**Figure 16. Pre-load Adjustment**

3. A **decal** has been placed on the side of the handle tube to assist the user in the adjustment of the spring.
4. Align the **arrow** on the adjustment screw with the letter "**J**" **COMBO** on the **decal**. The letter "**J**" stands for JA-Series Walk-Behind trowel.
5. Test the pitch control operation and adjust if necessary.

# JA-SERIES TROWEL— PRE-INSPECTION

## CAUTION



**NEVER** operate the trowel in a confined area or enclosed area structure that does not provide ample *free flow of air*.



**ALWAYS** wear approved eye and hearing protection before operating the trowel.



**NEVER** place hands or feet inside the guard rings while the engine is running. **ALWAYS** shut the engine down before performing any kind of maintenance service on the trowel.



It is recommended that the trowel's **kill switch** be used to stop the engine after every use. Doing this will verify that the switch is working properly and presents no danger to the operator.

## Before Starting

1. Read safety instructions at the beginning of manual.
2. Clean the **trowel**, removing dirt and dust, particularly the engine cooling air inlet, carburetor and air cleaner.
3. Check the air filter for dirt and dust. If air filter is dirty, replace air filter with a new one as required.
4. Check carburetor for external dirt and dust. Clean with dry compressed air.
5. Check fastening nuts and bolts for tightness.

## Engine Oil Check

1. To check the engine oil level, place the trowel on secure level ground with the engine stopped.
2. Remove the filler dipstick from the engine oil filler hole (Figure 17) and wipe it clean.

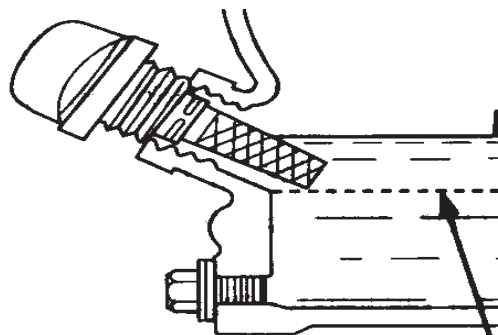

Figure 17. Engine Oil Dipstick (Removal)

3. Insert and remove the dipstick without screwing it into the filler neck. Check the oil level shown on the dipstick.
4. If the oil level is low (Figure 18), fill to the edge of the oil filler hole with the recommended oil type (Table 4).

### NOTE

Reference manufacturer engine manual for specific servicing instructions.

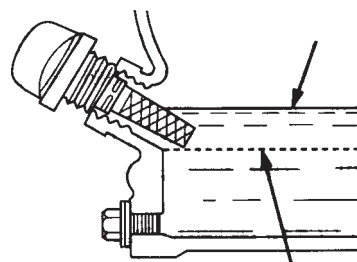

Figure 18. Engine Oil Dipstick (Oil Level)

Table 4. Oil Type

Season	Temperature	Oil Type
Summer	25°C or Higher	SAE 10W-30
Spring/Fall	25°C~10°C	SAE 10W-30/20
Winter	0°C or Lower	SAE 10W-10

# JA-SERIES TROWEL— PRE-INSPECTION



## Fuel Check

Motor fuels are highly flammable and can be dangerous if mishandled. **DO NOT** smoke while refueling. **DO NOT** attempt to refuel the trowel if the engine is *hot!* or *running*.

1. Remove the gasoline cap located on top of fuel tank.
2. Visually inspect to see if fuel level is low. If fuel is low, replenish with unleaded fuel.
3. When refueling, be sure to use a strainer for filtration. **DO NOT** top-off fuel. Wipe up any spilled fuel.

## Gearbox Oil

1. Determine if the **gearbox** oil is low by removing the oil plug located on the side of the gearbox. This plug will be marked by the "**check**" decal. See (Figure 19). The correct level of the lubrication oil should be to the bottom of the fill plug.

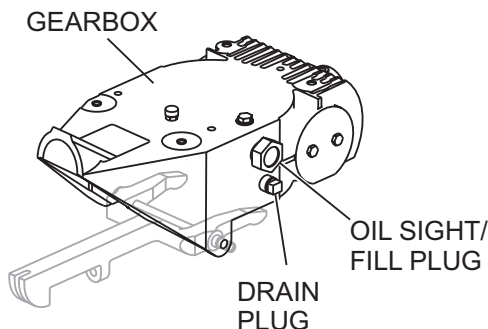

Figure 19. Gearbox

2. If oil does not reach the middle of the **sight glass** fill with type ISO 680 (Whiteman P/N 10139) gearbox lubricant oil until the oil level reaches the middle of the sight glass.

## V-belt Check

A worn or damaged V-belt can adversely affect the performance of the trowel. If a V-belt is defective or worn, simply replace the V-belt as outlined in the maintenance section of this manual.

## Blade Check

Check for worn or damaged blades. Check to see if one blade is worn out while the others look new. If this is the case there could be a blade pitch problem. Refer to the maintenance section of this manual for blade pitch adjustment procedure. Replace any worn blades.

## CONTROLS

### Safety Kill Switches

This trowel has been equipped with a safety kill switch or a hand operated clutch. Safety kill switches or hand clutches should be tested every time the engine is started.

### NOTE

**NEVER!** disable or disconnect the kill switch. It is provided for operator safety. Injury may result if it is disabled, disconnected or improperly maintained.

### Centrifugal Type Kill Switch

The switching mechanism of this switch (Figure 20) should operate freely and should **always** be kept in this condition. With the switch in the **OFF** position, the engine should not start or run. The purpose of this switch is to stop the engine in a runaway situation, (i.e. -the operator releasing the handle during operation).

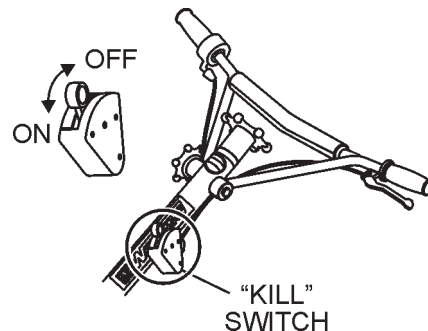

Figure 20. Centrifugal Kill Switch

### Hand Clutch

Some finisher models are equipped with a **hand operated clutch**. These units are not equipped with a safety kill switch. The unit automatically stops rotating when the clutch lever is released.

**DO NOT** let the machine sit unused with the engine at high speed for an extended period of time. It will cause premature belt wear or may destroy the belt. Always set the engine speed to idle when the hand clutch is disengaged.

# JA-SERIES TROWEL — INITIAL START-UP (GASOLINE ENGINE)

## CAUTION



The trowel is **heavy** and **awkward** to move around. Use proper heavy lifting procedures and **DO NOT lift the trowel by the guard rings**.

### Lifting the Trowel Onto a Slab.

#### Auxiliary Lifting Tube

Remove the auxiliary lifting tube located on top of the main handle. Insert the tube into the socket located on the opposite side of the gearbox (Figure 21) from the handle.

Make sure that the hole in the tube engages with the pin in the socket. With one person lifting from the main handle, and another lifting from the auxiliary lifting tube pick up the machine to move onto a slab.

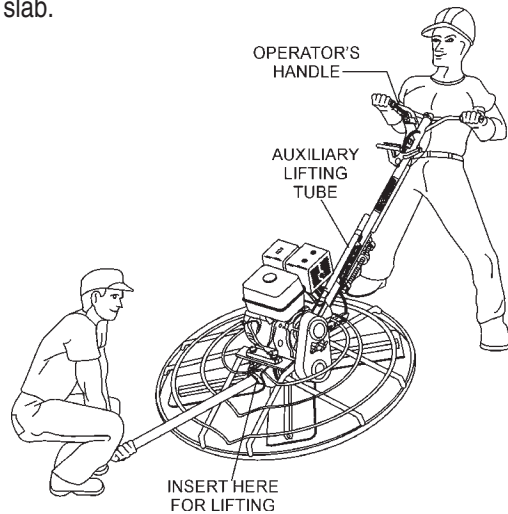

Figure 21. Lifting the Trowel

## CAUTION



The trowel must be stabilized by the person carrying the **operator's handle** (Figure 21). If it is not stabilized properly the handle may swing around and **flip** the trowel, thus causing damage to the trowel and bodily injury.

### Lifting Bale (Option)

The lift bale is optional on new trowels. It provides an optimal lift point for moving the trowel. **Lift Bales** or **forklift** can be used to lift a trowel up onto a building with a crane. See "**Optional Equipment**" section in this manual for ordering information.

Using a **crane** to move a machine with a lift bale is highly recommended, and is perfectly safe for the machine. Extra care should be taken when lifting the machine off the ground, though. Serious damage to the machine or personal injury could be caused by dropping a trowel.

This section is intended to assist the operator with the initial start-up of the walk-behind trowel. It is extremely important that this section be read carefully before attempting to use the trowel in the field.

**DO NOT** use your trowel until this section is thoroughly understood.

## CAUTION



**DO NOT** attempt to operate the trowel until the Safety, General Information and Inspection sections of this manual have been read and thoroughly understood. Depending on engine manufacturer, operating steps may vary. See engine manufacturer's operating manual.

### Starting the Engine (**HONDA** engine)

1. Place the engine **fuel valve lever** (Figure 22) to the "ON" position.

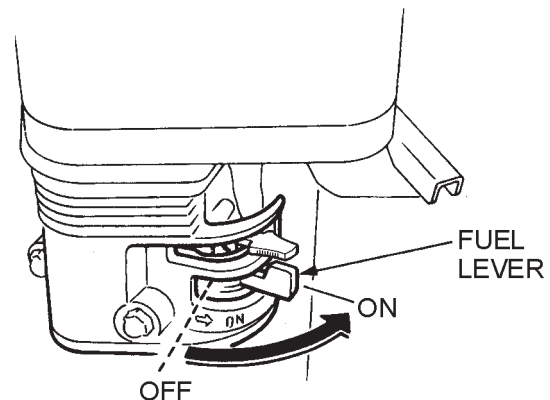

Figure 22. Engine Fuel Valve Lever

2. Rotate the throttle (Figure 23) toward the "RUN" position.

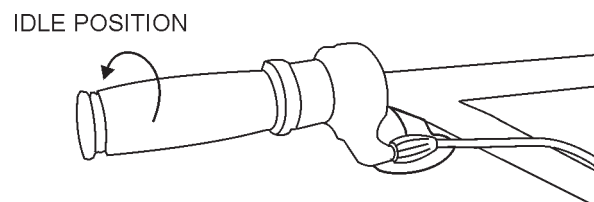

Figure 23. Throttle (Idle Position)

## JA-SERIES TROWEL — INITIAL START-UP (GASOLINE ENGINE)

- Place the *centrifugal kill switch* (Figure 24) in the "ON" position. For models that use this feature.

### CAUTION



**NEVER** disable or disconnect the centrifugal kill switch. It is provided for the operators' safety and injury may result if it is disabled, disconnected or improperly maintained.

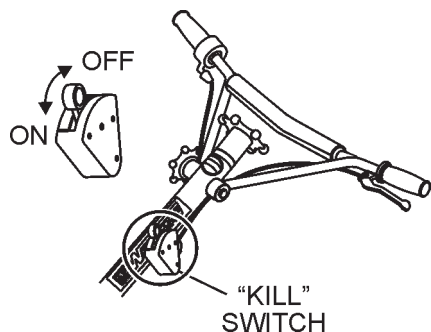

Figure 24. Centrifugal Kill Switch

- Place the *Choke Lever* (Figure 25) in the "OPEN" position

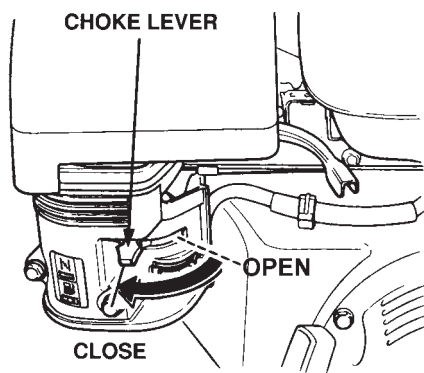

Figure 25. Engine Choke Lever

- Grasp the starter grip (Figure 26) and slowly pull it out. The resistance becomes the hardest at a certain position, corresponding to the compression point. Pull the starter grip briskly and smoothly for starting.

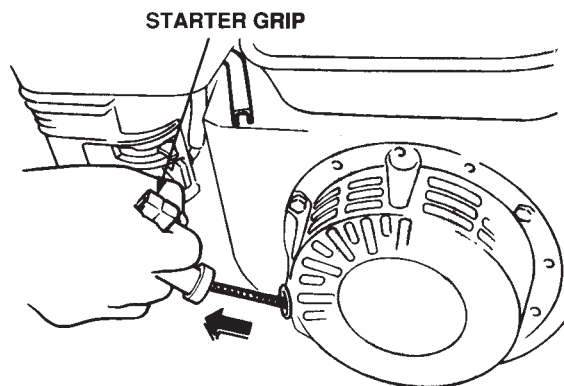

Figure 26. Starter Grip

- If the engine has started, slowly return the choke lever (Figure 25) to the **CLOSED** position. If the engine has not started repeat steps 1 through 5.
- Before the trowel is placed into operation, run the engine for several minutes. Check for fuel leaks, and noises that would associate with a loose guard ring and/or covers.
- To begin troweling, rotate the throttle (Figure 27) toward the "RUN" position.

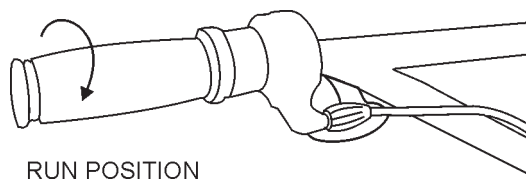

Figure 27. Throttle (Run Position)

The following steps are intended as a basic guide to machine operation, and are not to be considered a complete guide to concrete finishing. We suggest that all operators (experienced and novice) read "*Slabs on Grade*" published by the **American Concrete Institute, Detroit, Michigan**. Read the "Training" section of this manual for more information.

## Pitching The Blades

### Quick Pitch Handle

1. To pitch the blades upwards using the "**Quick-Pitch™**" **T-handle**, (Figure 28) simply squeeze the trigger lock and pull the **T-handle** towards the operator. Pushing the **T-handle** towards the engine will cause the blades to lay flat.

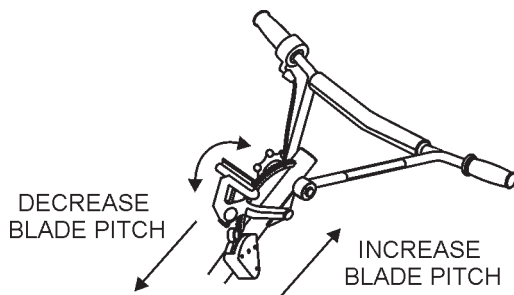

Figure 28. Quick-Pitch™ T-Handle

### Standard Handle

1. To pitch the blades upwards using the "**Standard**" handle, (Figure 29) simply turn the **star-wheel** clockwise. Turning the star wheel counter clockwise will cause the blades to lay flat.

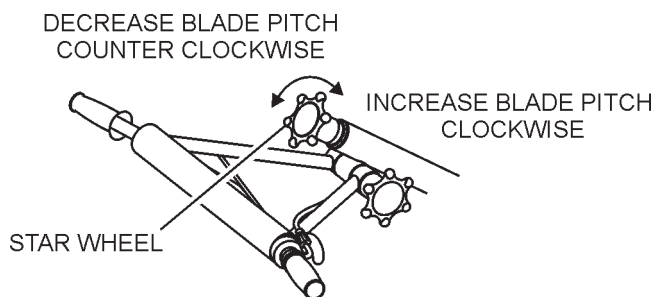

Figure 29. Standard Handle

## Maneuvering the Trowel

1. Get into the operator's position behind the handle. With a secure foothold and a firm grasp on the handles slowly increase the engine speed until the desired blade speed is obtained.

If your trowel has a **hand clutch** (Figure 30), set your engine speed with the throttle, then pull on the hand clutch lever to start the blades turning. Adjust the blade speed after the hand clutch is fully engaged.

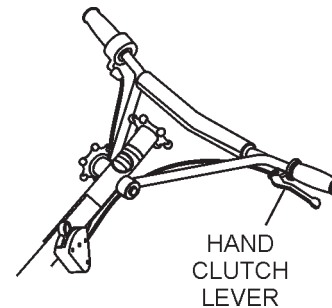

Figure 30. Hand Clutch Lever

2. To maneuver the trowel, gently lift up on or press down on the main trowel handle. To move the machine to the operator's left, **lift up** on the handle, to move machine to the right, **push down** on the handle.
3. The best method for finishing concrete is to slowly walk backwards (Figure 31) with the trowel, guiding the trowel from side to side. This will cover all footprints on wet concrete.
4. Remember that if you let go of the trowel, just step away and let the trowel come to a complete stop before trying to recover the trowel.

## JA-SERIES TROWEL — OPERATION

(Figure 31) below illustrates a typical walk-behind trowel application. Practice maneuvering the trowel. The trick is to let the trowel do the work.

Continue to practice maneuvering the trowel. Try to practice as if you were finishing a slab of concrete. Practice edging and covering a large area. Remember a good finishing technique is to work backwards. Be careful when moving backwards so that hazards can be avoided. The best way to get accustomed to the trowel is repeated use.

To move the trowel to the operator's left, **lift up** on the handle, to move the trowel to the right **push down** on the handle.

**Remember!** that if you let go of the trowel, just **step away** and let the trowel come to a complete **STOP** before trying to recover the trowel.

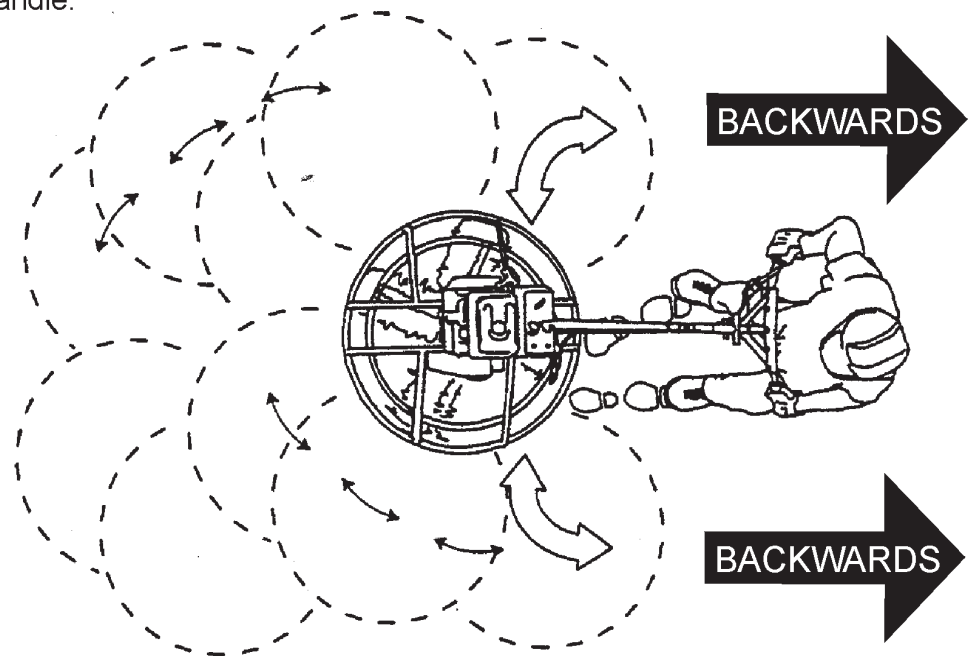

The best method for finishing concrete is to slowly walk **backwards** with the trowel, guiding the trowel from side to side. This will cover all footprints on wet concrete.

Figure 31. Maneuvering The Trowel

### CAUTION



**NEVER** place your **feet** or **hands** inside the guard rings while starting or operating this equipment.

### CAUTION



**ALWAYS** keep clear of **rotating** or **moving** parts while operating this equipment.

# JA-SERIES TROWEL — OPTIONS

## Blades

### NOTE

Blades should be changed when they fail to finish concrete in a satisfactory manner.

Blades are a vital part of finishing concrete. This trowel, or **finisher**, has been designed to finish concrete and the blades are built to stringent quality standards out of the finest trowel steel. If you need replacement blades, consult your parts list in this manual for part numbers and order them from your Multiquip parts dealer or importer.

### Combo Blades

This trowel was equipped with combination **float/finish** (Figure 32) blades as original equipment. These blades have been designed for optimum performance in both the floating and finishing operations. These blades are versatile and should take care of most troweling needs.

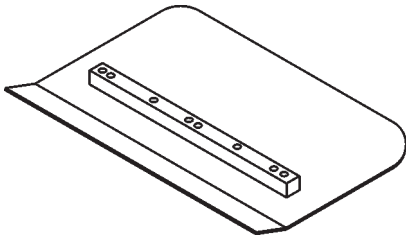

Figure 32. Combination Blade

### Finish Blades (Optional)

These blades (Figure 33) have been specifically designed for finish operations with this trowel. They will provide a premium surface finishing capability from your trowel. They should only be used after the concrete has set to the point where the trowel does not sink into the concrete when placed on it.

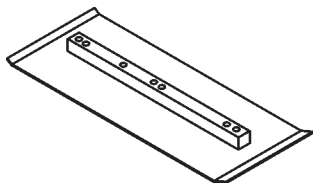

Figure 33. Finish Blade

### Clip-On Float Blades (Optional)

These blades will clip (Figure 34) on to an existing installed blade, allowing your finisher to float on “wet” concrete so that the troweling operation can begin as early as possible. They are easily removable, so that after the floating operation, when the concrete is sufficiently cured, they can be removed to expose the finish blades for continued troweling.

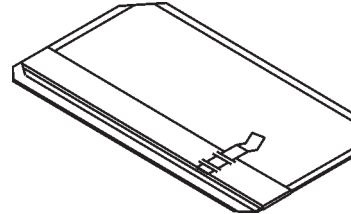

Figure 34. Clip-On Float Blade

### Float Discs (Optional)

These round discs (Figure 35) attach to the spiders and allow the machine to “float” on “wet” concrete. The disc design allows early floating and easy movement from wet to dry areas. They are also very effective in embedding large aggregates and surface hardeners.

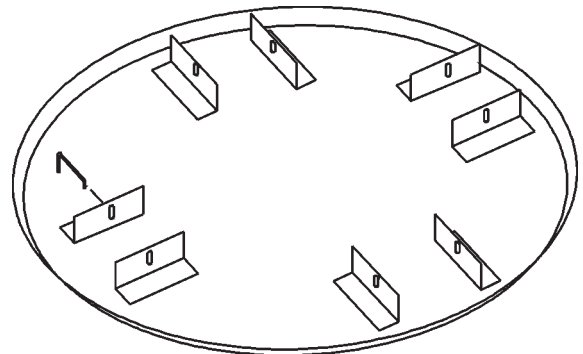

Figure 35. Float Disk

## Grinding Attachments

Available grinding attachments are used for grinding surface imperfections or joints. These attachments allow greater utilization of your trowel. Figure 36 illustrates a typical grinding disk assembly, complete with hub and stone mounting plate.

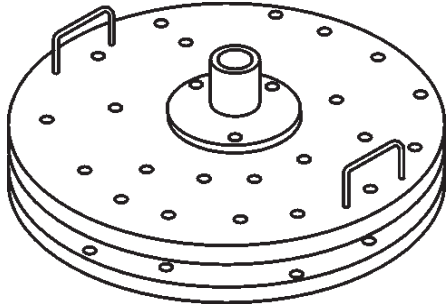

Figure 36. Grinding Disk

## Trowel Arm Adjustment Tool

If blades show uneven wear patterns or some tend to wear out faster than others, the trowel arms may need to be adjusted. Whiteman makes a special tool (Figure 38) that will adjust all of the trowel arms consistently. The Trowel Arm Fixture P/N is 1817.

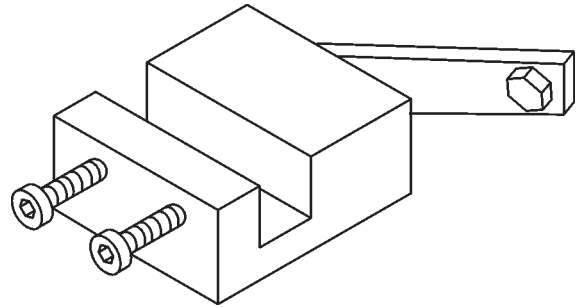

Figure 38. Trowel Arm Adjustment Fixture

## Lifting Bale

There is a heavy duty, center balance type lifting bale (Figure 37) made specifically for your trowel. These bales are ideal for lifting and transporting your trowel. They are designed to lift the finisher and balance it on its center of gravity, providing great stability while lifting. This option is not available on electric trowel models.

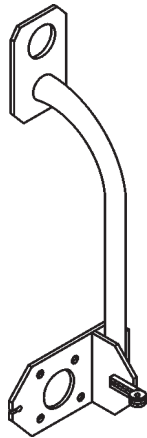

Figure 37. Lifting Bale

# JA-SERIES TROWEL — MAINTENANCE

## NOTE

See the engine manual supplied with your machine for appropriate engine maintenance schedule and troubleshooting guide for problems.

At the front of the book (Page 7) there is a "**Daily Pre-Operation Checklist**". Make copies of this checklist and use it on a daily basis.

## CAUTION!



**ALWAYS** allow the engine to cool before servicing. **NEVER** attempt any maintenance work on a **hot!** engine.



## MAINTENANCE SCHEDULE

### Daily (8-10 Hours)

1. Check the oil level in the engine crankcase and gear box, fill as necessary.

2. Check V-belt.

### Weekly (50-60 Hours)

1. Relube arms, thrust collar and clutch.
2. Replace blades if necessary.
3. Check and clean or replace the engine air filter as necessary.
4. Replace engine oil and filter as necessary, see engine manual.

### Monthly (200-300 Hours)

1. Remove, clean, reinstall and relube the arms and thrust collar. Adjust the blade arms.
2. Remove, clean, reinstall clutch.

### Yearly (2000-2500 Hours)

1. Check and replace if necessary the arm bushings, thrust collar bushings and shaft seals.
2. Check pitch control cables for wear.
3. Adjust blade speed.

## Trowel Arm Adjustment Procedure

## NOTE

The following procedure should be followed to adjust trowel arms when it becomes apparent that the trowel is finishing poorly or in need of routine maintenance.

A **level**, clean area to test the trowel prior to and after is essential. Any unlevel **spots** in the floor or debris under the trowel blades will give an incorrect perception of adjustment. Ideally, a 5 x 5" three-quarter inch thick **flat** steel plate should be used for testing.

1. To determine which blades need adjustment, place the trowel in the test area (three-quarter inch thick plate) and look for the following conditions:
  - Pitch the blades as flat as possible and look at the **adjustment bolts**. They should all barely make contact with the **lower wear plate** on the spider. If you can see that one of them is not making contact, some adjustment will be necessary.
  - Is the machine wearing out blades unevenly (i.e. one blade is completely worn out while the others look new)?

(Figure 39) below illustrates a "**worn spider bushings or bent trowel arms**". Check to see that adjustment bolt is barely touching (0.10" max. clearance) lower wear plate. All alignment bolts should be spaced the same distance from the lower wear plate.

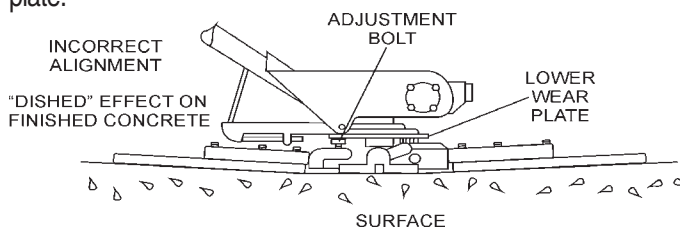

Figure 39. Worn Spider Plate

(Figure 40) below illustrates the "**correct alignment**" for a spider plate (as shipped from the factory).

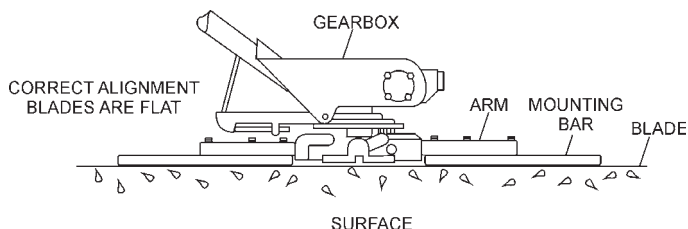

Figure 40. Correct Spider Plate Alignment

# JA-SERIES TROWEL — MAINTENANCE

2. Start engine, and bring trowel blades up to full speed and look for the following conditions:
  - Does the trowel have a perceived rolling or bouncing motion when in use?
  - Look at the trowel while it is running, does the guard ring “rock up and down” relative to the ground?

## Spider Removal

1. Once it is determined that an adjustment is required, remove the spider assembly from the gearbox shaft as follows:
  - a. Locate the cone point square head set screw (Figure 41) and attached jam nut found on the side of the spider assembly.

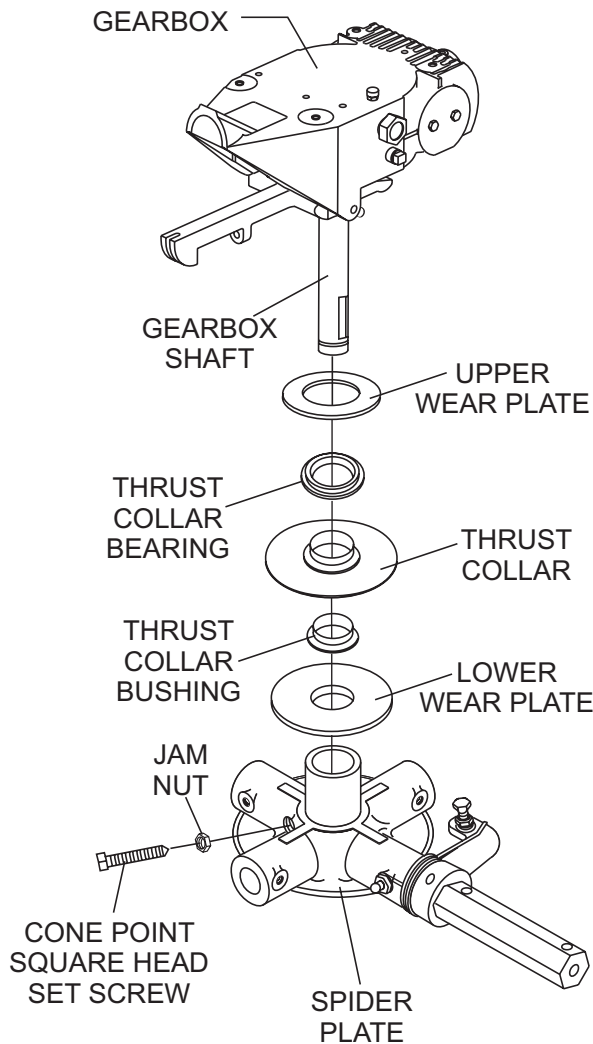

Figure 41. Spider/Gearbox Removal

- b. Loosen the jam nut and cone point square head set screw, and carefully lift the **upper trowel assembly** off of the spider assembly. A slight tap with a rubber mallet may be necessary to dislodge the spider from the main shaft of the gearbox.

## Trowel Arm Removal

1. Each trowel arm is held in place at the spider plate by a hex head bolt (zerk grease fitting) and a roll pin. Remove both the hex head bolt and the roll pin (Figure 42) from the spider plate.
2. Remove the trowel arm from the spider plate.

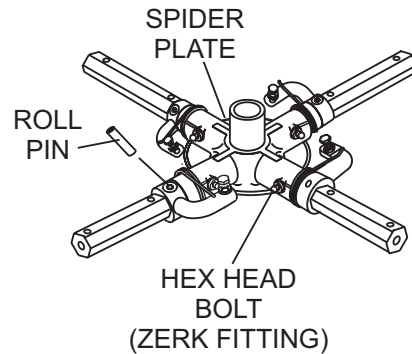

Figure 42. Removing Roll Pin and Zerk Grease Fitting

3. Should the trowel arm inserts (bronze bushing) come out with the trowel arm, remove the bushing from the trowel arm and set aside in a safe place. If the bushing is retained inside the spider plate, carefully remove the bushing.
4. Examine the bronze trowel arm bushing insert (Figure 43), clean if necessary. Replace bushing if out of round or worn.

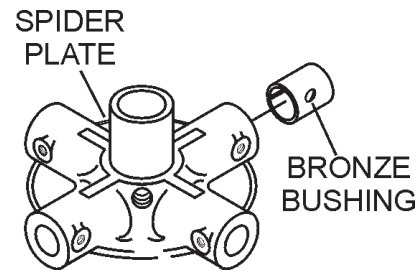

Figure 43. Bronze Bushings

# JA-SERIES TROWEL — MAINTENANCE

## Trowel Blade Removal

1. Remove the trowel blades from the trowel arm by removing the two hex head bolts (Figure 44) from the trowel arm. Set blades aside.

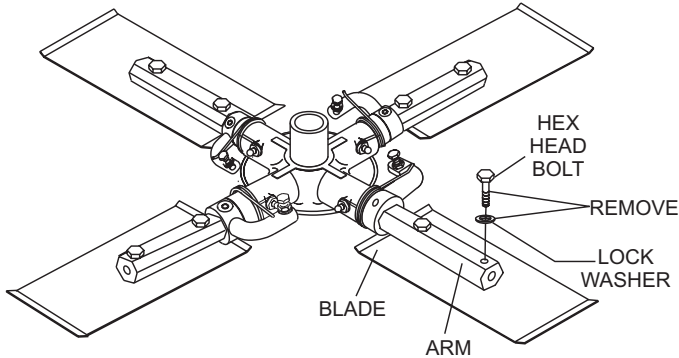

Figure 44. Trowel Blades

2. **Wire brush** any build-up of concrete from all six sides of the trowel arm. Repeat this for the remaining three arms.

## Trowel Arm Flatness Test

1. Using a piece of 3/4 inch thick steel plate or any surface which is **true** and **flat**, check all **six sides** of each trowel arm for flatness.
2. Check each of the six sides of the trowel arm (hex section only) using a ten thousandths of an inch (max.) feeler gauge (Figure 45) between the flat of the trowel arm and an **extremely flat** test surface.

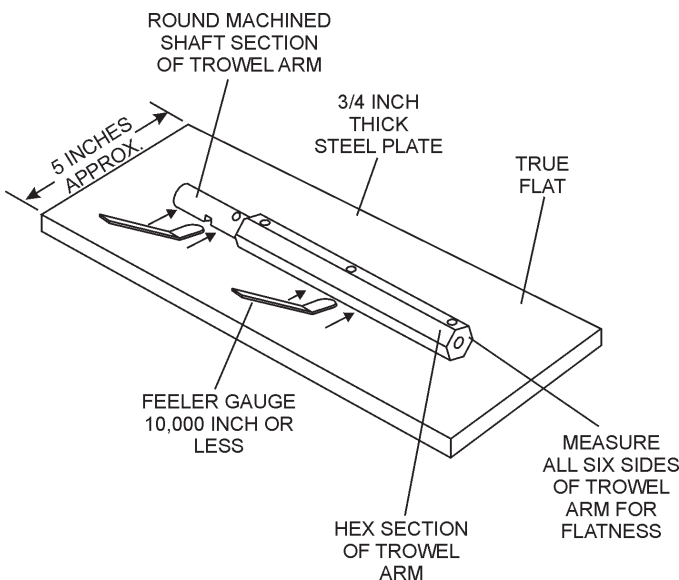

Figure 45. Trowel Arm Flatness Test

3. If the trowel arm is found to be **uneven** or **bent**, replace the trowel arm. A bent trowel will not allow the trowel to operate in a smooth fluid rotation.
4. Next, check each of the six sides of the round machined shaft section of the trowel arm. Each section should have the **same clearance** between the round of the trowel arm shaft and the test surface.

## NOTE

Trowel arms can be damaged by rough handling or by striking exposed plumbing or forms while in operation. **ALWAYS** look-out for objects which might cause damage to the trowel arms.

## Trowel Arm Adjustment

Shown in (Figure 46) is the adjustment fixture with a trowel arm inserted. As each trowel arm is locked into the fixture, the arm bolt is adjusted to where it contacts a stop on the fixture. This will consistently adjust all of the trowel arms, keeping the finisher as flat and evenly pitched as possible.

1. Locate the trowel arm adjustment tool P/N 1817. Set the adjustment tool for a clock-wise blade rotation, meaning the fixture arm is in the **"UP"** position.

# JA-SERIES TROWEL — MAINTENANCE

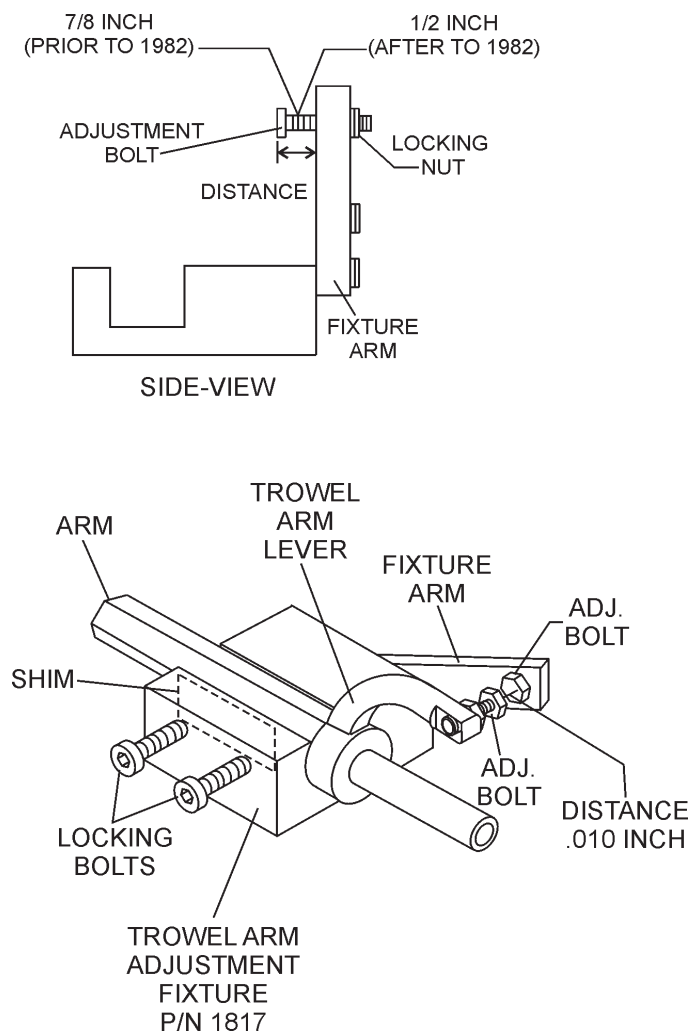

**Figure 46. Trowel Arm Adjustment Tool**

2. Trowels manufactured prior to June of 1982 require that the distance from the end of the adjusting bolt and the fixture arm must be 7/8" (Figure 46). Conversely, trowels manufactured after June of 1982 require that the distance from the end of the adjusting bolt and the fixture arm must be 1/2".

3. Un-screw the locking bolts on the adjustment tool, and place the trowel arm into the adjustment fixture channel as shown in (Figure 46). A *thin shim* may be required to cover the blade holes on the trowel arm. Make sure to align the trowel adjustment bolt with the fixture adjustment bolt.
4. Using an allen wrench, tighten the locking bolts on the adjustment tool and securely lock the trowel arm in place.
5. Loosen the locking nut on the trowel arm lever, then turn the trowel arm adjusting bolt until it barely touches (.010") the adjusting bolt on the fixture.
6. After the correct adjustment has been made, tighten lock nut on trowel arm lever to lock in place.
7. Loosen locking bolts on adjustment fixture, and remove trowel arm from fixture.
8. Repeat steps 2-7 for the remaining trowel arms.

## Re-Assembly

1. Clean and examine the upper/lower wear plates and thrust collar. Examine the entire spider assembly. Wire brush any concrete or rust build-up. If any of the spider components are found to be damaged or out of round, replace them.
2. Make sure that the bronze trowel arm bushing is not damage or out of round. Clean the bushing if necessary. If the bronze bushing is damage or worn, replace it.
3. Reinstall bronze bushing onto trowel arm.
4. Repeat steps 2 -3 for each trowel arm.
5. Make sure that the spring tensioner is in the correct position to exert tension on the trowel arm.
6. Insert all trowel arms with levers into spider plate (with bronze bushing already installed) using care to align grease hole on bronze bushing with grease hole fitting on spider plate.
7. Lock trowel arms in place by tightening the hex head zerk grease fitting and jam nut.
8. Re-install the blades back onto the trowel arms
9. Reinstall **lower wear plate**, **thrust collar** and **upper wear ring** in the **reverse order** that they were dis-assembled onto the spider shaft. Make sure that there is little or no lateral movement between the thrust collar and the spider shaft.

# JA-SERIES TROWEL — MAINTENANCE

10. Carefully lift the **upper trowel assembly**, line up the key-way on gear box main shaft and insert into spider assembly
11. Reinstall square head cone point into spider plate and tighten in place. Tighten jam nut. Use care in making sure point of set screw engages groove in gear box main shaft.
12. Lubricate all grease points (zerk fittings) with premium "**Lithum 12**" based grease, conforming to NLG1 Grade #2 consistency.

## Testing

1. Place trowel in test area, start engine and test trowel for smoothness.
2. If trowel bounces has excessive vibration or does not run smoothly repeat alignment procedure.

## Changing a Blade

Whiteman recommends that **all the blades be changed at the same time**. The machine may wobble or bounce if only some of the blades are changed at one time.

1. Place the machine on a flat, level surface. Adjust the blade pitch control to make the blades as flat as possible. Note the blade orientation on the trowel arm.

### NOTE

Before removing the blades, please note the orientation of the blade on the trowel arm.

2. Remove the three bolts and lock washers that secure the blade to the trowel arm. Remove the blade.
3. Using a wire brush, scrape all concrete particles and foreign debris from the trowel arm.
4. Install the new trowel blade onto the trowel arm. Make sure blade is installed correctly, maintaining the proper orientation for direction of rotation.
5. Reinstall the three bolts and lock washers that secure the blade to the trowel arm. Tighten all three bolts securely.
6. Repeat steps 1-4 for all remaining blades.

## Hand Clutch Adjustment

Some trowels are equipped with a hand-operated clutch instead of an automatic centrifugal clutch. Two types of hand clutches have been installed. Both are belt-tightener type clutches. They operate by removing **slack** in the V-belt which then transmits power from the engine to the gearbox.

There are two reasons to adjust the hand clutch: 1) operator comfort; 2) initial belt stretch and break-in.

The easiest and most simple adjustment is to adjust the clutch cable housing using the adjustment nut (Figure 47) located on the clutch lever. Rotating the nut provides either more or less (depending upon the direction of rotation) clutch engagement.

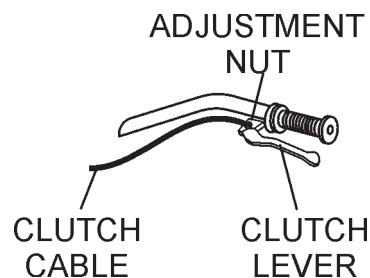

Figure 47. Clutch Cable Adjustment

## Hand Clutch Disengagement

1. Start the trowel as outlined in the "**Initial Start-up**" section in this manual. Move the throttle lever so that the engine is running about 1/4 to 1/3 of full speed.
2. Grip the trowel handle firmly and carefully engage the clutch by squeezing the clutch lever toward the handle with your left hand. After the trowel is stabilized and you feel comfortable with its operation, use your right hand to adjust the housing adjustment nut.
3. Rotating the nut so that it backs out of the lever housing increases the engagement and also the squeezing force required to keep it engaged.

Too much squeezing force may cause premature hand fatigue. Too little squeezing force may cause belt slippage and premature belt wear. Each operator should experiment with the adjustment to get the optimum combination of squeeze force and belt grip.

4. After initial break-in (approximately 8 hours) the above procedure should be repeated to attain optimum operator comfort and belt wear.
5. After considerable belt wear, the adjustments mentioned above may have a little or no effect on clutch engagement. If this is the case, the belt should be replaced.

# JA-SERIES TROWEL — TROUBLESHOOTING (TROWEL)

**TABLE 5. TROUBLESHOOTING**

SYMPTOM	POSSIBLE PROBLEM	SOLUTION
Engine running rough or not at all.	Kill switch malfunction?	Make sure that the kill switch is ON or replace switch if necessary.
	Fuel?	Look at the fuel system. Make sure there is fuel being supplied to the engine. Check to ensure that the fuel filter is not clogged.
	Ignition?	Check to ensure that the ignition switch has power and is functioning correctly.
Safety kill switch not functioning.	Other problems?	Consult engine manufacturer's manual.
	Loose wire connections?	Check wiring. Replace as necessary.
	Bad contacts?	Replace switch.
If trowel "bounces, rolls concrete, or makes uneven swirls in concrete".	Blades?	Make certain blades are in good condition, not excessively worn. Finish blades should measure no less than 2" (50mm) from the blade bar to the trailing edge, combo blades should measure no less than 3.5" (89mm). Trailing edge of blade should be straight and parallel to the blade bar.
	Spider?	Check that all blades are set at the same pitch angle as measured at the spider. A field adjustment tool is available for height adjustment of the trowel arms (see Optional Equipment).
	Bent trowel arms?	Check the spider assembly for bent trowel arms. If one of the arms is even slightly bent, replace it immediately.
	Trowel arm bushings?	Check the trowel arm bushings for tightness. This can be done by moving the trowel arms up and down. If there is more than 1/8" (3.2 mm) of travel at the tip of the arm, the bushings should be replaced. All bushings should be replaced at the same time.
	Thrust collar?	Check the flatness of the thrust collar by rotating it on the spider. If it varies by more than 0.02" (0.5 mm) replace the thrust collar.
	Thrust collar bushing?	Check the thrust collar by rocking it on the spider. If it can tilt more than 3/32" (2.4 mm) [as measured at the thrust collar O.D.], replace the bushing in the thrust collar.
	Thrust bearing worn?	Check the thrust bearing to see that it is spinning free. Note: Thrust cap, replace if necessary.
Machine has a perceptible rolling motion while running.	Main shaft?	The main output shaft of the gearbox assembly should be checked for straightness. The main shaft must run straight and cannot be more than 0.003" (0.08 mm) out of round at the spider attachment point.
	Yoke?	Check to make sure that both fingers of the yoke press evenly on the wear cap. Replace yoke as necessary.
	Blade Pitch?	Check to ensure that each blade is adjusted to have the same pitch as all other blades. Adjust per maintenance section in manual.

# JA-SERIES TROWEL — TROUBLESHOOTING (TROWEL)

**TABLE 6. TROUBLESHOOTING (CONTINUED)**

SYMPTOM	POSSIBLE PROBLEM	SOLUTION
Clutch slipping or sluggish response to engine speed change.	Worn V-belts?	Replace V-belt.
	Dirty centrifugal clutch?	Disassemble and clean clutch.
	Defective or worn out centrifugal clutch?	Replace entire clutch.
	Hand clutch out of adjustment?	Adjust per instructions in maintenance section of this manual.
	Worn or defective hand clutch parts?	Replace parts as necessary.
	Worn bearings in gearbox?	Rotate input shaft by hand. If shaft rotates with difficulty, check the input and output shaft bearings. Replace as necessary.
	Worn or broken gears in gearbox?	Verify that the gearbox shaft rotates when the input shaft is rotated. Replace both the worm and worm gear as a set.

# JA-SERIES TROWEL — TROUBLESHOOTING (ENGINE)

## TABLE 7. TROUBLESHOOTING (ENGINE)

SYMPTOM	POSSIBLE CAUSE	SOLUTION
Difficult to start, "fuel is available, but no SPARK at spark plug".	Spark plug bridging?	Check gap, insulation or replace spark plug.
	Carbon deposit on spark plug?	Clean or replace spark plug.
	Short circuit due to deficient spark plug insulation?	Check spark plug insulation, replace if worn.
	Improper spark plug gap?	Set to proper gap.
Difficult to start, "fuel is available, and SPARK is present at the spark plug".	ON/OFF switch is shorted?	Check switch wiring, replace switch.
	Ignition coil defective?	Replace ignition coil.
	Improper spark gap, points dirty?	Set correct spark gap and clean points.
	Condenser insulation worn or short circuiting?	Replace condenser.
Difficult to start, "fuel is available, spark is present and compression is normal".	Spark plug wire broken or short circuiting?	Replace defective spark plug wiring.
	Wrong fuel type?	Flush fuel system, and replace with correct type of fuel.
	Water or dust in fuel system?	Flush fuel system.
	Air cleaner dirty?	Clean or replace air cleaner.
Difficult to start, "fuel is available, spark is present and compression is low".	Choke Open?	Close Choke.
	Suction/exhaust valve stuck or protruded?	Re-seat valves.
	Piston ring and/or cylinder worn?	Replace piston rings and or piston.
	Cylinder head and/or spark plug not tightened properly?	Torque cylinder head bolts and spark plug.
No fuel present inside priming bulb.	Head gasket and/or spark plug gasket damaged?	Replace head and spark plug gaskets.
	Fuel not available in fuel tank?	Fill with correct type of fuel.
	Fuel filter clogged?	Replace fuel filter.
	Fuel tank cap breather hole clogged?	Clean or replace fuel tank cap.
	Air in fuel line?	Bleed fuel line.

# JA-SERIES TROWEL — EXPLANATION OF CODES IN REMARKS COLUMN

How to read the marks and remarks used in this parts book.

## Section 1: Items Found In the “Remarks” Column

Serial Numbers-Where indicated, this indicates a serial number range (inclusive) where a particular part is used.

Model Number-Where indicated, this shows that the corresponding part is utilized only with this specific model number or model number variant.

## Section 2: Items Found In the “Remarks” Column

Serial Numbers-Where indicated, this indicates a serial number range (inclusive) where a particular part is used.

Model Number-Where indicated, this shows that the corresponding part is utilized only with this specific model number or model number variant.

## Section 3: Items Found In the “Items Number” Column

All parts with same symbol in the number column, \*, #, +, %, or ■, belong to the same assembly or kit.

Note: If more than one of the same reference number is listed, the last one listed indicates newest (or latest) part available.

### NOTE

The contents of this parts catalog are subject to change without notice.

# JA-SERIES TROWEL — SUGGESTED SPARE PARTS

## JA-SERIES TROWEL 1 TO 3 UNITS WITH HONDA GX-160K1QA2 ENGINE.

### *1 to 3 Units*

Qty .....	P/N .....	Description
2	20856	SAFETY SWITCH
1	20285	CABLE STANDARD HANDLE
1	20297	CABLE QUICK PITCH™
1	20435	LEVER W/CABLE
4	1157 A	BUSHING
1	2828	ARM (11-3/4")
4	1162 A	LUBE CAP
4	1167 A	SCREW
4	1456	NUT
4	1875	WASHER
4	1322	SCREW
1	21046	GASKET KIT
1	21047	BEARING KIT
4	1247	RUBBER GROMMET
4	1245	SPACER
1	2827	ARM (16-1/2")
2	0152 3	BELT (A-28) HONDA W/HND CLUTCH
1	10968	THRUST COLLAR KIT
2	9807955846	SPARK PLUG HONDA
2	17620ZH7023	TANK CAP (HONDA)
2	17210ZE2505	AIR CLEANER ELEMENT (HONDA)
2	17218ZE2505	FILTER OUTER (HONDA)

## JA-SERIES TROWEL 1 TO 3 UNITS WITH ROBIN EH17-2 ENGINE.

### *1 to 3 Units*

Qty .....	P/N .....	Description
3	20478	GRIP
2	20856	SAFETY SWITCH
1	20285	CABLE STANDARD HANDLE
1	20297	CABLE QUICK PITCH™
1	20435	LEVER W/CABLE
4	1157 A	BUSHING
1	2828	ARM (11-3/4")
4	1162 A	LUBE CAP
4	1167 A	SCREW
4	1456	NUT
4	1875	WASHER
4	1322	SCREW
1	21046	GASKET KIT
1	21047	BEARING KIT
4	1247	RUBBER GROMMET
4	1245	SPACER
1	2827	ARM (16-1/2")
2	0152 3	BELT (A-28) ROBIN W/HND CLUTCH
1	10968	THRUST COLLAR KIT
2	0650140031	SPARK PLUG (ROBIN)
2	0430430015	TANK CAP (ROBIN)
2	2703261008	AIR CLEANER ELEMENT (ROBIN)

# JA-SERIES TROWEL — NAMEPLATE AND DECALS

## NAMEPLATES AND DECALS

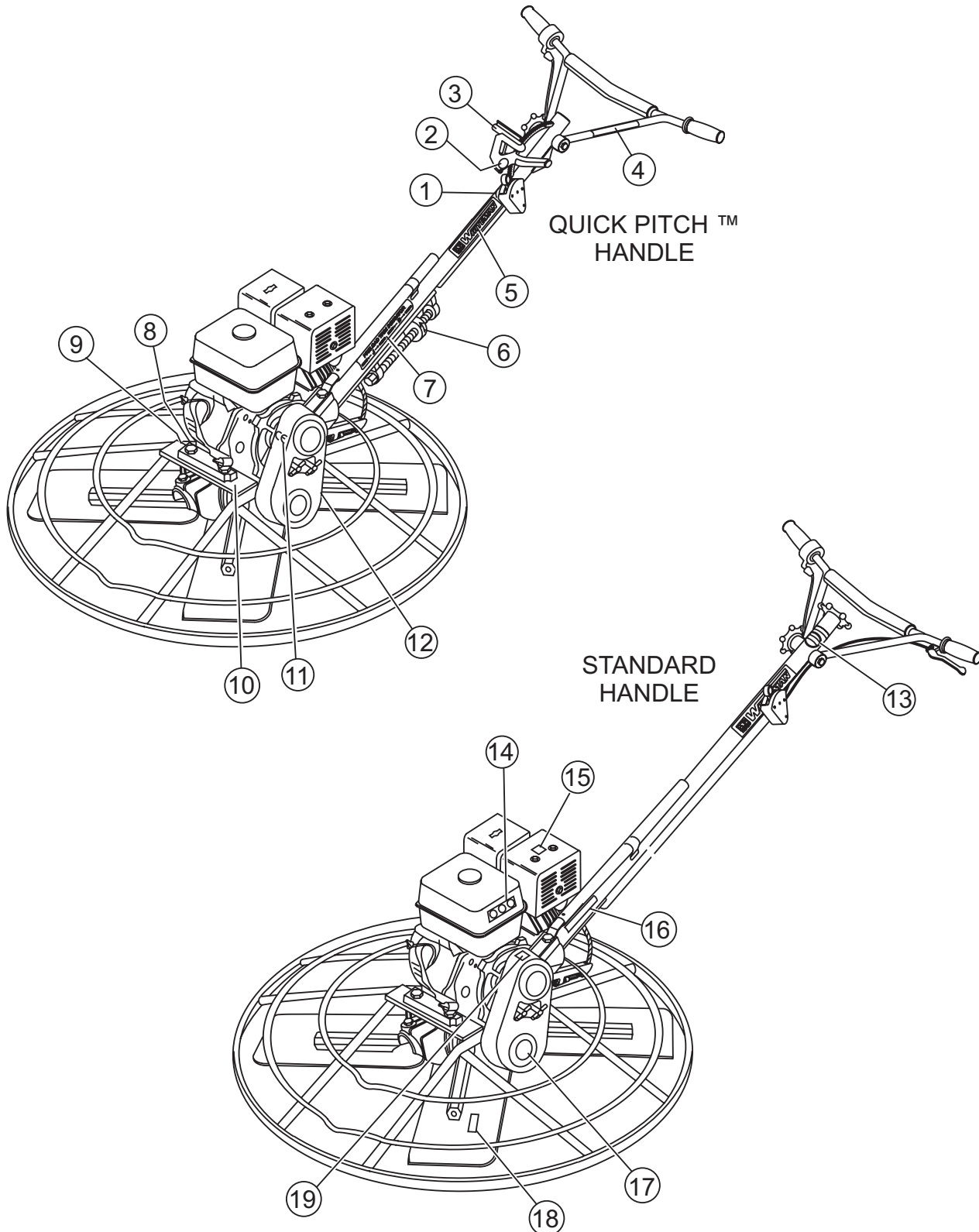

# JA-SERIES TROWEL — NAMEPLATE AND DECALS

## NAMEPLATE AND DECALS

<u>NO.</u>	<u>PART NO.</u>	<u>PART NAME</u>	<u>QTY.</u>	<u>REMARKS</u>
1	1758	DECAL: QUICK PITCH™ HANDLE	1	
2	12405	DECAL: QUICK PITCH™ HANDLE INSERT	2	
3	20527	DECAL: QUICK PITCH™ WARNING	1	
4	20526	DECAL: QUICK PITCH™ LATCH WARNING	1	
5	2942	DECAL: MQ WHITEMAN 13"	1	
6	1736	DECAL: ARROWS	1	
7	1735	DECAL: PRE-LOAD INDICATOR	1	
8 *	11246	DECAL: OIL CHECK	1	
9		NAMEPLATE .....	1	..... CONTACT MULTIQIP ..... PARTS DEPT.
10	1940	DECAL: MQ WHITEMAN (SMALL)	1	
11	11092	DECAL: CE	1	
12 *	11246	DECAL: GEAR DRIVE	1	
13	1492	DECAL: STANDARD HANDLE (FINISHER)	1	
14 *	11247	DECAL: HELMET, FOOT AND GLOVE	1	
15 *	11246	DECAL: HOT	1	
16	1261	DECAL: DO NOT LIFT	1	
17	1848	DECAL: POWER TROWEL	1	
18	2938	DECAL: METRIC	1	
19 *	11246	DECAL: BELT DRIVE	1	
	12620	DECAL, KIT .....	1	..... INCLUDES ITEMS W/*

SEE DECAL ILLUSTRATIONS ON PAGE 12

# JA-SERIES TROWEL — STANDARD HANDLE ASSY.

STANDARD HANDLE ASSY.

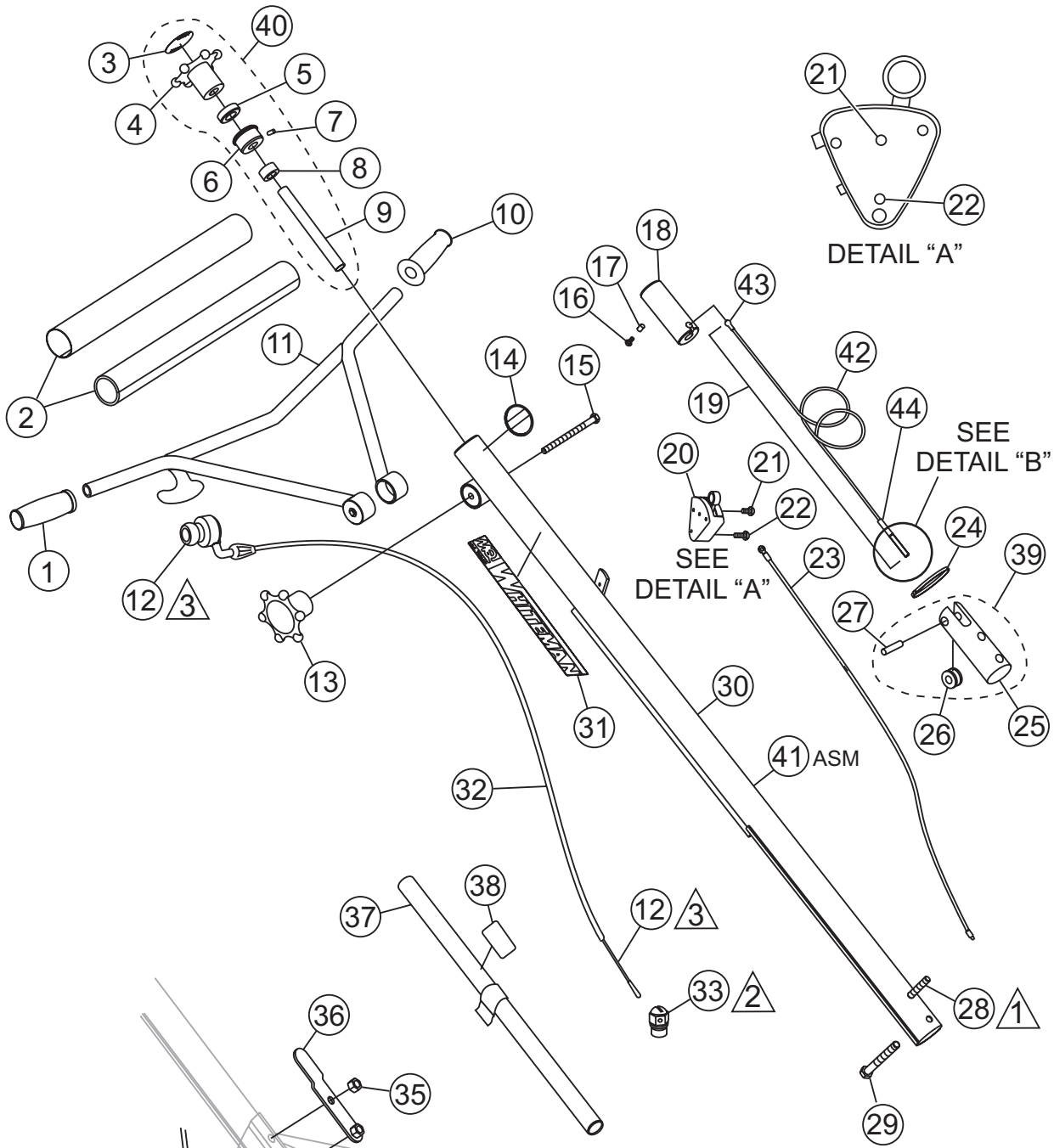

- ▲ 1 APPLY THREAD LOCK (LOCTITE 242 BLUE OR EQUIVALENT).
- ▲ 2 PART OF ENGINE ASSEMBLY.
- ▲ 3 CABLE IS ATTACHED TO THROTTLE AND SEALED AT THE FACTORY. ORDERABLE AS A UNIT ONLY.

# JA-SERIES TROWEL — STANDARD HANDLE ASSY.

## STANDARD HANDLE ASSY.

<u>NO.</u>	<u>PART NO.</u>	<u>PART NAME</u>	<u>QTY.</u>	<u>REMARKS</u>
1	20463	GRIP, HANDLE RIGHT	1	
2	20774	COVER, PAD HANDLE	1	
3*	20818	DECAL, STD PITCH	1	
4*	20817	WHEEL, HAND J-B HANDLE	1	
5*	0281	BEARING, THRUST, NICE 607	1	
6*	20282	BEARING, TROWEL CONTROL	1	
7*	0122C	SCREW, SHS 3/8-16 X 1/2	1	
8*	3615	COLLAR, SET 3/4 ID	1	
9*	1478	SHAFT, TROWEL CONTROL	1	
10	20478	GRIP, HANDLE LEFT	1	
11	12556	HANDLE, ADJUSTABLE	1	
12	20435	THROTTLE LEVER W/CABLE	1	
13	20439	WHEEL ASSY., HAND	1	
14	1492	DECAL, CUSTOM 2 1/2 CHROME	1	
15	20438	SCREW, HHC 3/8-16 X 5.00	1	
16	0786	SCREW, BHC 1/4- 20 X 3/8 NYL PATCH, NP	1	
17	0786A	SPACER, .360 X 17/64 X 1/8L	1	
18	20287	SLIDE BLOCK TROWEL CONTROL	1	
19	20285	CABLE ASSY., LENGTH 48.29" STD FINISHER ...	1	INCLUDES ITEMS W/■
20	20856	SWITCH ASSY., KILL .....	1	INCLUDES ITEMS W/\$
21\$	1602	SCREW, RHM 10-24 X 3/8	1	
22\$	20988	SCREW, FHSC PHILLIPS 8-32 X 1 1/4	1	
23	20514	WIRE ASSY., KILL SWITCH	1	
24	1662	TIE, CABLE TY-RAP, BLACK	1	
25#	20275	BLOCK, SUPPORT	1	
26#	1118	PULLEY, SUPPORT BLOCK	1	
27#	20279	PIN, SUPPORT BLOCK 3/8 X 1.59	1	
28	21017	SCREW, HHC 3/8-16 X 3 1/2 FULL THREAD	1	
29	1493	SCREW, HHC 3/8-16 X 3 1/4	1	
30	12567	HANDLE, J/B STD	1	
31	2942	DECAL, MQ WHITEMAN, 13"	1	
32	20434	HOUSING, CABLE 74"	1	
33	20845	SWIVEL, THROTTLE CABLE	1	
34	1116	NUT, BRASS JAM 5/16-18	2	
35	10133	NUT, NYLOC 3/8-16	1	
36	20392	BRACKET, LIFT TUBE	1	
37	20471	HANDLE, LIFT ASSY.	1	
38	1261	DECAL, CAUTION, LIFT HANDLE	1	
39	20280	BLOCK, CABLE ASSY .....	1	INCLUDES ITEMS W/#
40	20819	HAND WHEEL ASSY., PITCH CONTROL .....	1	INCLUDES ITEMS W/*
41		HANDLE ASSY., STD FINISHERS .....	1	CONTACT SALES DEPT.
42	20301■	CABLE, CNTL 5/32 GALV AIRCRAFT 46.03"	1	
43	20421■	CLEVIS, BALL END CONTROL CABLE	1	
44	A8638■	END-BOLT, CNTL CABLE	1	

# JA-SERIES TROWEL — QUICK PITCH™ HANDLE ASSY.

QUICK PITCH™ T-HANDLE ASSY.

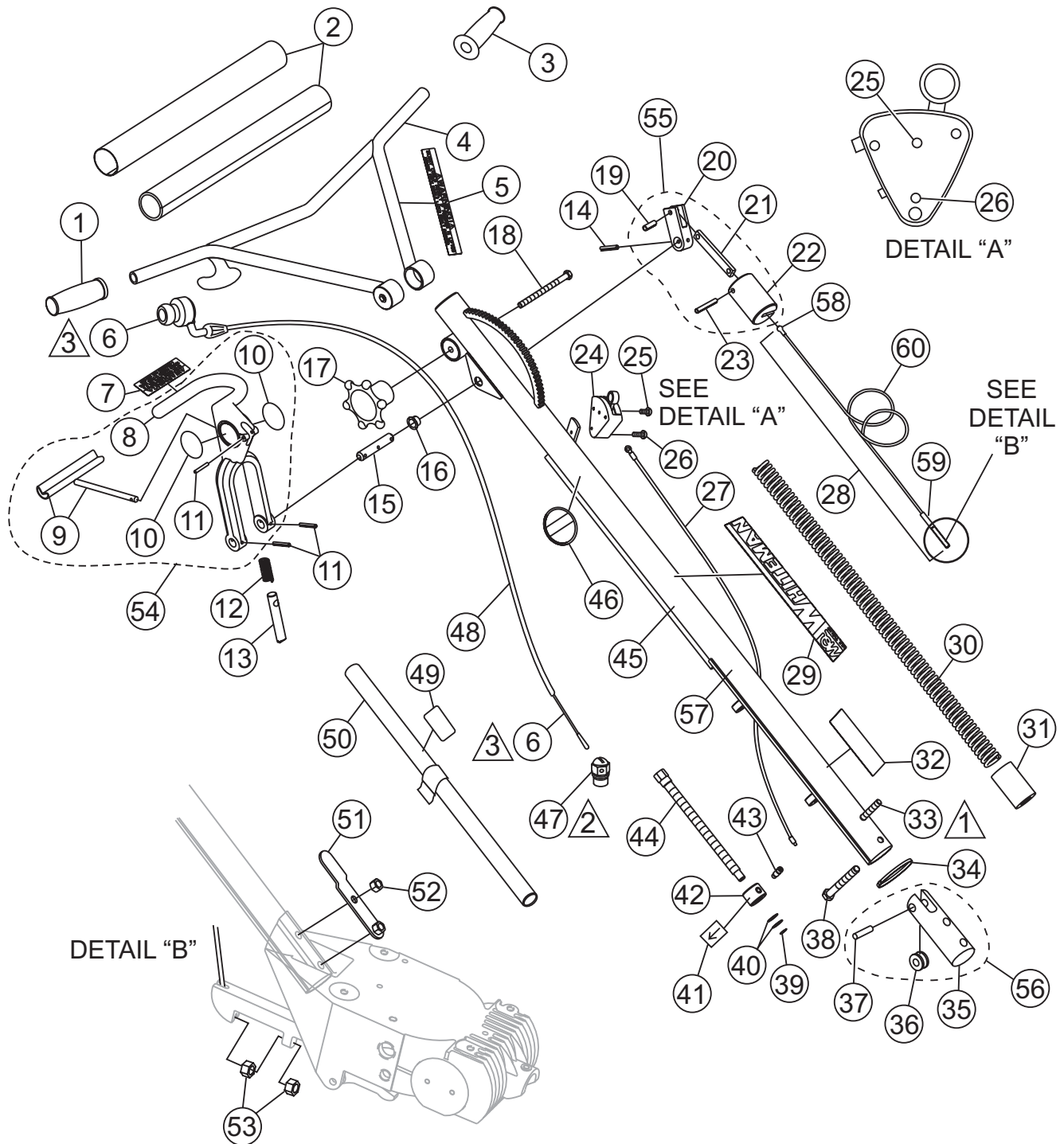

- ▲ 1 APPLY THREAD LOCK (LOCTITE 242 BLUE OR EQUIVALENT).
- ▲ 2 PART OF ENGINE ASSEMBLY.
- ▲ 3 CABLE IS ATTACHED TO THROTTLE AND SEALED AT THE FACTORY. ORDERABLE AS A UNIT ONLY.

# JA-SERIES TROWEL — QUICK PITCH™ HANDLE ASSY.

## QUICK PITCH HANDLE ASSY.

<u>NO.</u>	<u>PART NO.</u>	<u>PART NAME</u>	<u>QTY.</u>	<u>REMARKS</u>
1	20463	GRIP, HANDLE RIGHT	1	
2	20774	COVER, PAD HANDLE	1	
3	20478	GRIP, HANDLE LEFT	1	
4	12556	HANDLE, ADJUSTABLE	1	
5	20526	DECAL, LATCH WARNING	1	
6	20435	THROTTLE LEVER W/CABLE	1	
7	20527	DECAL, Q.P. WARNING	1	
8*	20389	HANDLE, QUICK-PITCH™	1	
9*	1746	TRIGGER, QP CHROMED	1	
10*	12405	DECAL, WHITEMAN QUICK-PITCH™	2	
11*	1729	PIN, ROLL 3/16 X 1 1/4	3	
12*	1706	SPRING, ENCLOSED QP CLAMP	1	
13*	20437	PIN, QP LATCH	1	
14	4568	PIN, ROLL 3/16 X 1	1	
15	1711	SHAFT, CONTROL QP	1	
16	1719	BUSHING, PIVOT PLATE	1	
17	20439	WHEEL ASSY., HAND	1	
18	20438	SCREW, HHC 3/8-16 X 5.00	1	
19+	1731	PIN, ROLL 1/4 X 3/4	1	
20+	20443	ARM, SLIDE CONTROL	1	
21+	1709	CONNECTOR, QP CONTROL ARM	1	
22+	20269	LINKAGE, QP CONTROL	1	
23+	20276	PIN, ROLL 1/4 X 1 3/4	1	
24	20856	SWITCH ASSY., KILL .....	1	INCLUDES ITEMS W/\$
25\$	1602	SCREW, RHM 10-24 X 3/8	1	
26\$	20988	SCREW, FHSC PHILLIPS 8-32 X 1 1/4	1	
27	20514	WIRE ASSY., KILL SWITCH	1	
28	20297	CABLE ASSY., QP CONTROL, 45" .....	1	INCLUDES ITEMS W/■
29	2942	DECAL, MQ WHITEMAN, 13"	1	
30	1715	SPRING, COUNTER BALANCE	1	
31	20270	BLOCK, QP ADJUSTMENT	1	
32	1735	DECAL, PRELOAD TRIM INDICATOR	1	
33	21017	SCREW, HHC 3/8-16 X 3 1/2 FULL THREAD	1	
34	1662	TIE, CABLE, TY-RAP BLACK	1	
35#	20275	BLOCK, SUPPORT	1	
36#	1118	PULLEY, SUPPORT BLOCK	1	
37#	20279	PIN, SUPPORT BLOCK 3/8 X 1.59	1	
38	1493	SCREW, HHC 3/8-16 X 3 1/4	1	
39	1737	SNAP RING, TRUARC #5100-50	1	
40	1733	WASHER, 1/2 X 1/32, HARDENED	2	

# JA-SERIES TROWEL — QUICK PITCH™ HANDLE ASSY.

## QUICK PITCH HANDLE ASSY.

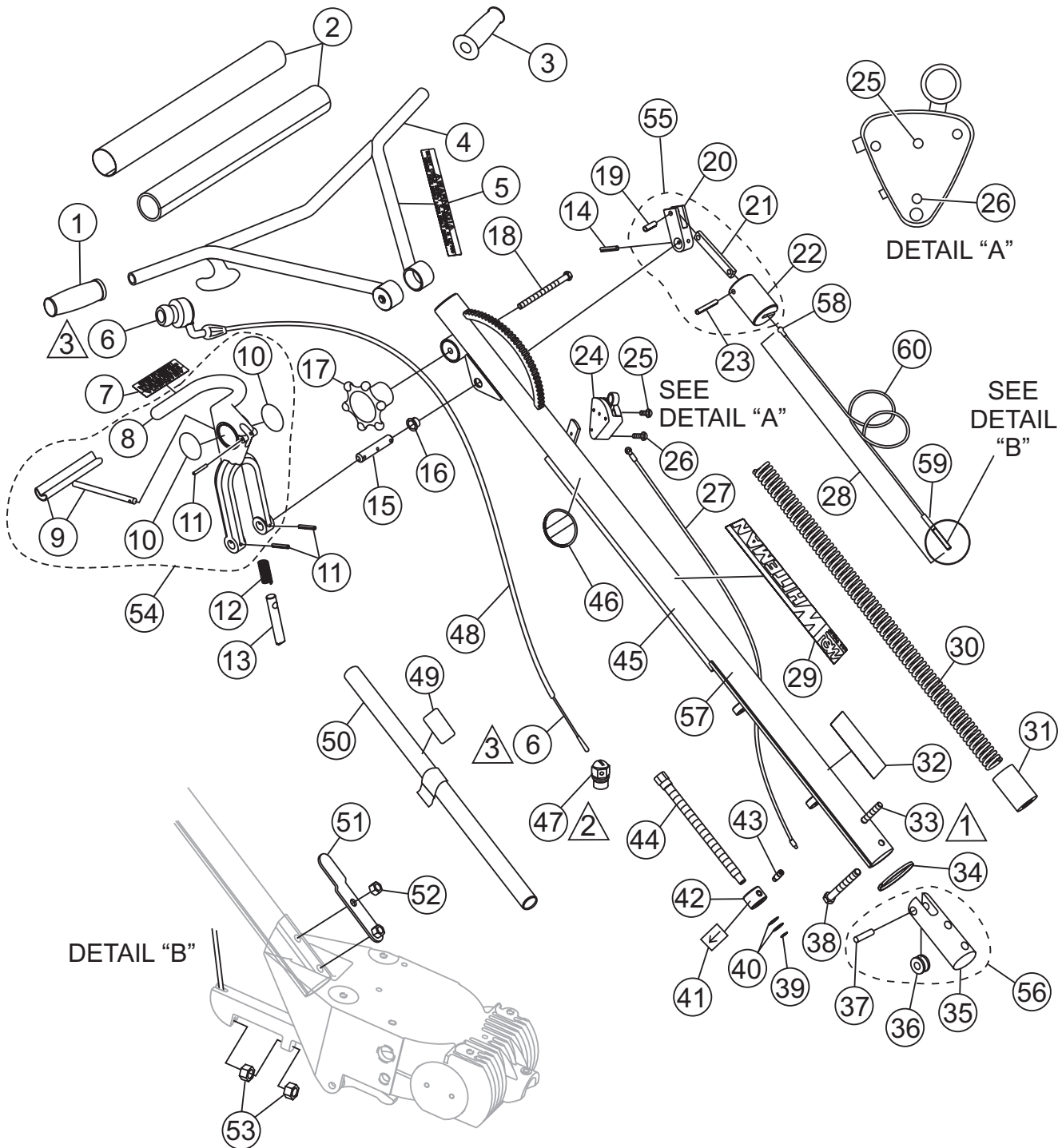

- ▲ 1 APPLY THREAD LOCK (LOCTITE 242 BLUE OR EQUIVALENT).
- ▲ 2 PART OF ENGINE ASSEMBLY.
- ▲ 3 CABLE IS ATTACHED TO THROTTLE AND SEALED AT THE FACTORY. ORDERABLE AS A UNIT ONLY.

# JA-SERIES TROWEL — QUICK PITCH™ HANDLE ASSY.

## QUICK PITCH HANDLE ASSY.

<u>NO.</u>	<u>PART NO.</u>	<u>PART NAME</u>	<u>QTY.</u>	<u>REMARKS</u>
41	1736	DECAL, ARROW	1	
42	1718	NUT, QP TRIM CTRL ADJ	1	
43	1732	BOLT, STRIPPER 3/8 X 1/2	1	
44	1717	SCREW, QP TRIM ADJUSTMENT	1	
45	12642	TUBE, MAIN HANDLE	1	
46	1758	DECAL, PATENT QP	1	
47	20845	SWIVEL, ENGINE THROTTLE CABLE	1	
48	20434	HOUSING, THROTTLE CABLE 74"	1	
49	1261	DECAL, CAUTION, LIFT HANDLE	1	
50	20471	HANDLE, LIFT ASSY.	1	
51	20392	BRACKET, LIFT TUBE	1	
52	10133	NUT, NYLOC 3/8-16	1	
53	1116	NUT, BRASS JAM 5/16-18	2	
54	20390	TRIGGER, QP ASSY. ....	1	INCLUDES ITEMS W/*
55	20293	LINKAGE, QP CONTROL ASSY. ....	1	INCLUDES ITEMS W/+
56	20280	BLOCK, CABLE ASSY. ....	1	INCLUDES ITEMS W/#
57		HANDLE ASSY., MAIN .....	1	CONTACT SALES DEPT.
58■	20421	CLEVIS, BALL END CONTROL CABLE	1	
59■	A8638	END-BOLT, CNTRL CABLE	1	
60■	20271	CABLE, CNTL 5/32 GALV AIRCRAFT 43.19"	1	

# JA-SERIES TROWEL — THRUST BEARING KIT ASSY.

THRUST BEARING KIT ASSEMBLY.

## THRUST BEARING KIT No. 10968

### OLD STYLE THRUST BEARING NO LONGER USED

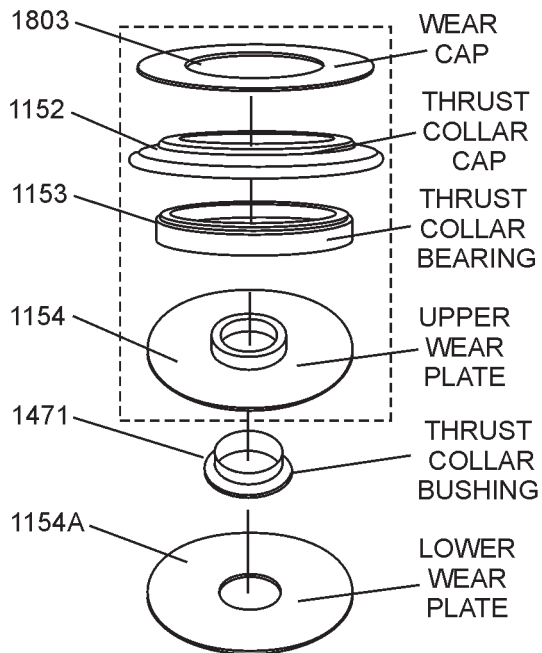

### NEW STYLE THRUST BEARING

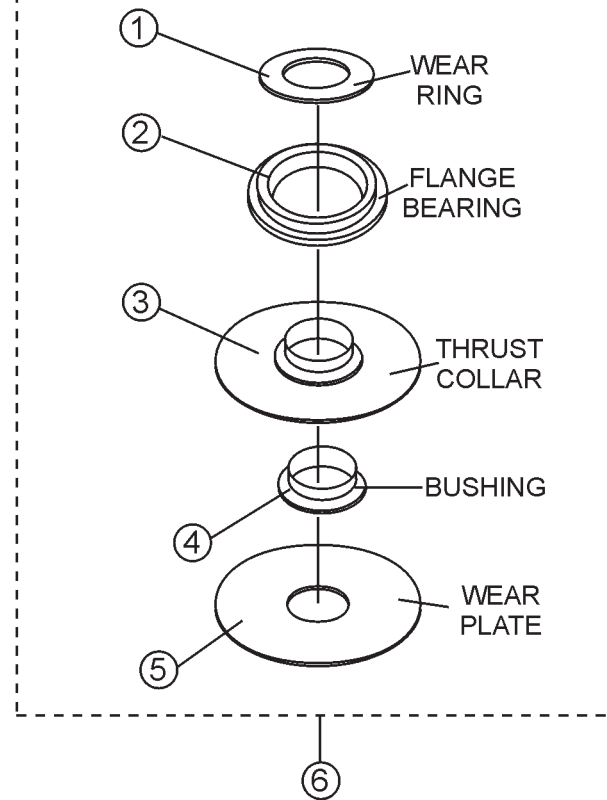

WHEN RE-ORDERING ***MUST*** USE  
THRUST BEARING KIT P/N 10968.  
***OLD STYLE*** IS NOT AVAILABLE.

# JA-SERIES TROWEL — THRUST BEARING KIT ASSY.

THRUST BEARING KIT ASSEMBLY.

<u>NO.</u>	<u>PART NO.</u>	<u>PART NAME</u>	<u>QTY.</u>	<u>REMARKS</u>
1*	12208	WEAR RING	1	
2*	12778	FLANGE BEARING	1	
3*	10793	THRUST COLLAR W/BUSHING	1	
4*	1471	BUSHING	1	
5*	1154A	LOWER WEAR PLATE	1	
6	10968	THRUST BEARING KIT .....	1 .....	INCLUDES ITEMS W/*

# JA-SERIES TROWEL — 4-BLADE SPIDER ASSY.

3 AND 4 BLADE SPIDER ASSY.

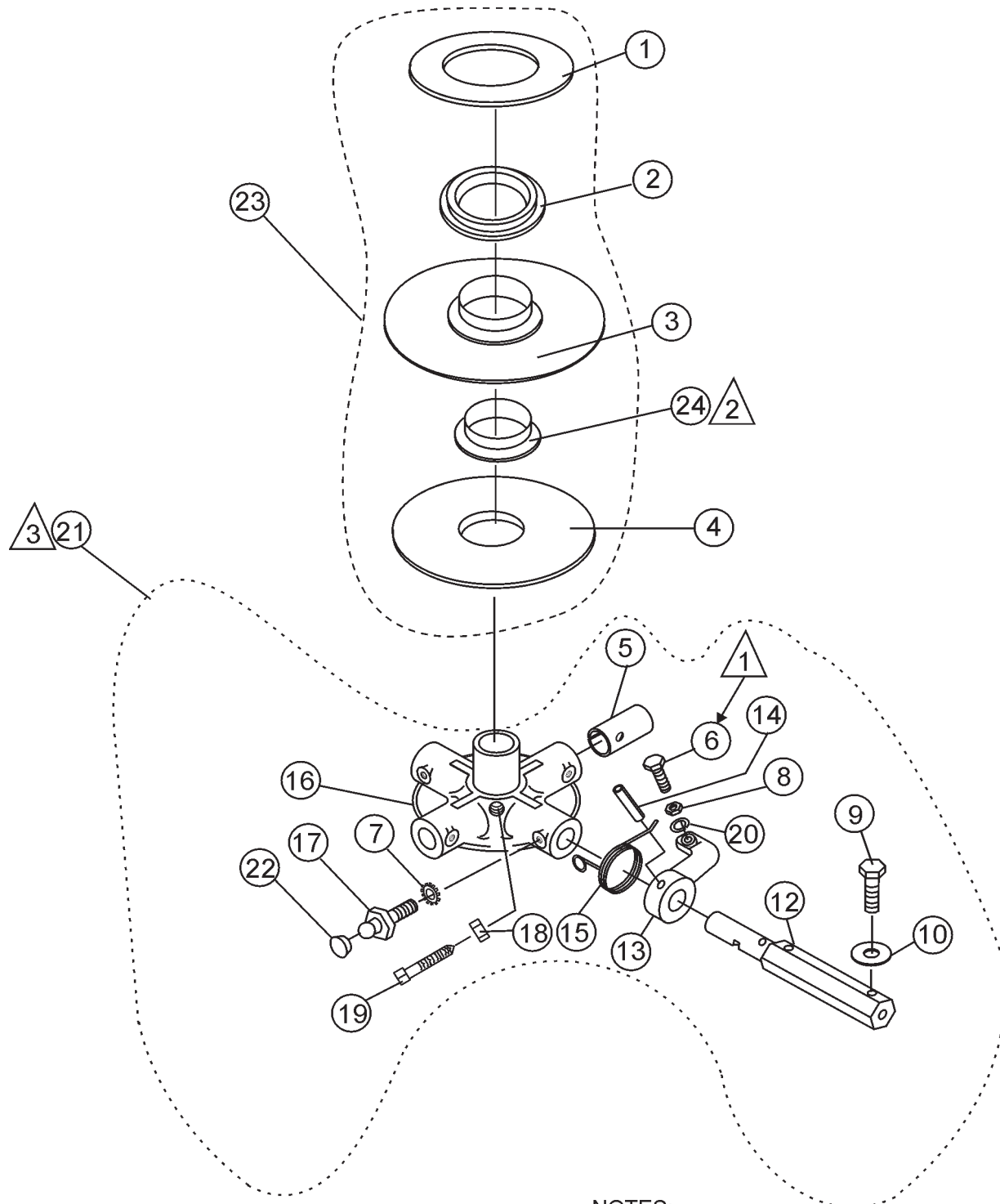

NOTES:

△ 1 APPLY LOCTITE P/N 1477

△ 2 INCLUDED WITH ITEM 3 OR CAN BE ORDERED SEPARATELY (P/N 1471).

△ 3 SPIDER ASSEMBLIES P/N 1489 AND 1490 INCLUDES ALL ITEMS WITHIN OUTLINE.

# JA-SERIES TROWEL — 4-BLADE SPIDER ASSY.

## 4 BLADE SPIDER ASSY.

<u>NO.</u>	<u>PART NO.</u>	<u>PART NAME</u>	<u>QTY.</u>	<u>REMARKS</u>
1*	12208	WEAR RING	1	
2*	12778	FLANGE BEARING	1	
3*	10793	THRUST COLLAR .....	1	INCLUDES ITEMS W/#
4*	1154A	WEAR PLATE	1	
5\$	1157A	BEARING INSERT	4	
6\$	0164B	RADIUS HEAD 3/8- 16 x 1-1/4"	4	
7\$	1875	INT. SHKP. WASHER 3/8"	4	
8\$	1876	JAM NUT 3/8- 16	4	
9\$	0105	HHCS 5/16- 18 x 1-1/2"	8	
10\$	0161C	LOCK WASHER 5/16"	8	
12\$	2826	TROWEL ARM 9-3/4	4	
13\$	1163	TROWEL ARM LEVER	4	
14\$	4164	ROLL PIN 5/16 x 1-3/4"	4	
15\$	1316	SPRING (RIGHT HAND)	4	
16\$	1161	SPIDER PLATE ONLY	1	
17\$	1322	RETAINING SCREW ASSY.	4	
18\$	1456	HEX NUT 3/8-16	1	
19\$	1167A	SHSS 3/8-16 x 1-1/2" CONE POINT	1	
20\$	0166A	LOCK WASHER 3/8"	4	
21	1215	SPIDER PLATE ASSY. (4 BLADE) .....	1	INCLUDES ITEMS W/\$
22	1162A	LUBRA- CAP	4	
23	10968	THRUST BEARING KIT .....	1	INCLUDES ITEMS W/*
24*#	1471	THRUST COLLAR BUSHING	1	

# JA-SERIES TROWEL — GEARBOX AND ENGINE MOUNTS ASSY.

## GEARBOX AND ENGINE MOUNTS ASSY.

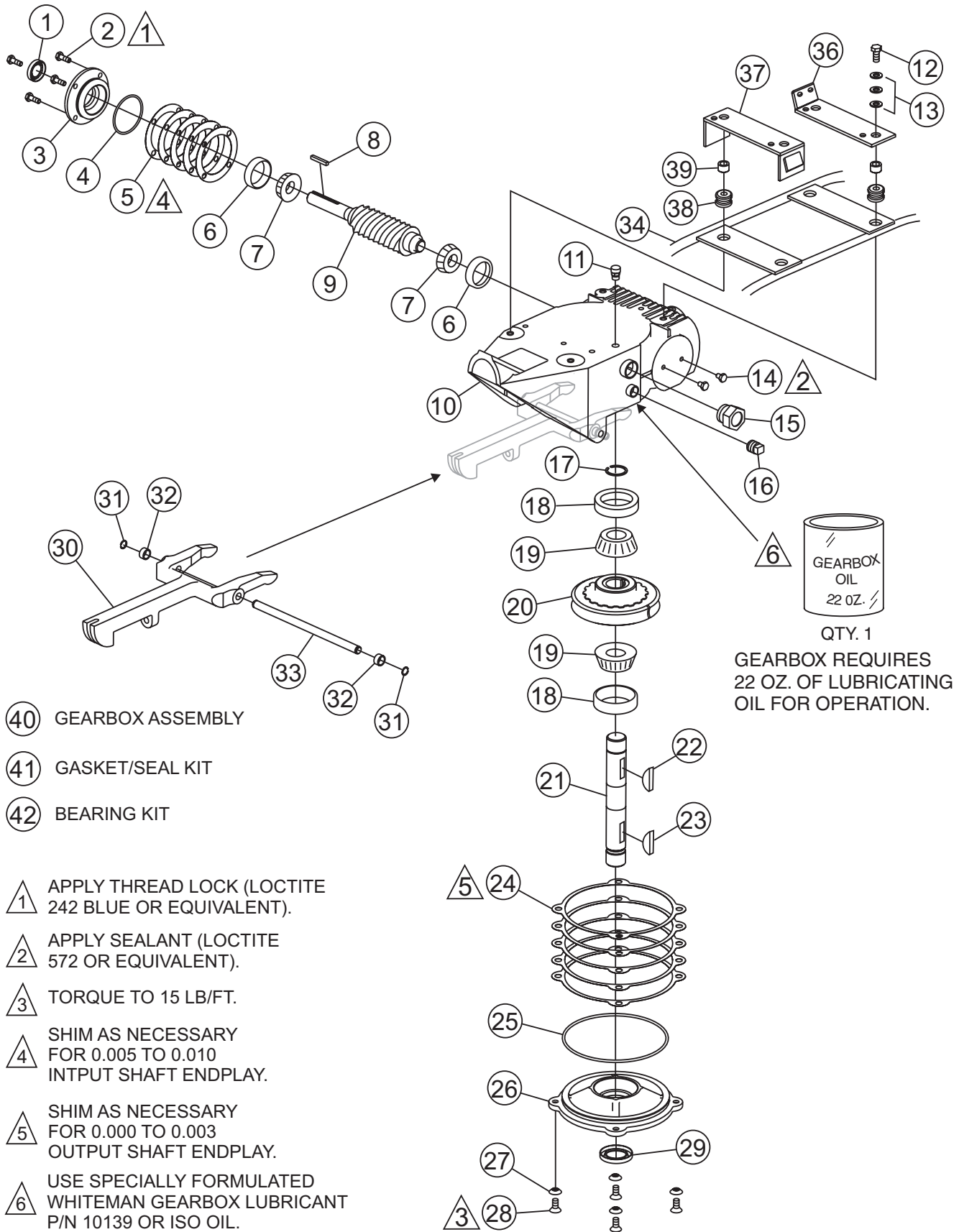

40 GEARBOX ASSEMBLY

41 GASKET/SEAL KIT

42 BEARING KIT

1 APPLY THREAD LOCK (LOCTITE 242 BLUE OR EQUIVALENT).

2 APPLY SEALANT (LOCTITE 572 OR EQUIVALENT).

3 TORQUE TO 15 LB/FT.

4 SHIM AS NECESSARY FOR 0.005 TO 0.010 INPUT SHAFT ENDPLAY.

5 SHIM AS NECESSARY FOR 0.000 TO 0.003 OUTPUT SHAFT ENDPLAY.

6 USE SPECIALLY FORMULATED WHITEMAN GEARBOX LUBRICANT P/N 10139 OR ISO OIL.

# JA-SERIES TROWEL — GEARBOX AND ENGINE MOUNTS ASSY.

## GEARBOX AND ENGINE MOUNTS ASSY.

<u>NO.</u>	<u>PART NO.</u>	<u>PART NAME</u>	<u>QTY.</u>	<u>REMARKS</u>
1%*	0753	SEAL, OIL NATIONAL #470954	1	
2%	0131A	SCREW, HHC 1/4-20 X 3/4	4	
3%	12876	FLANGE, INPUT SHAFT	1	
4%*	20395	RING, O -139 BUNA N	1	
5%*	20397	SHIM, INPUT 0.002 THICK	1	
	20398	SHIM, INPUT 0.003 THICK	1	
	20399	SHIM, INPUT 0.005 THICK	1	
	20400	SHIM, INPUT 0.010 THICK	1	
	20401	SHIM, INPUT 0.020 THICK	1	
6%#	20466	BEARING, CUP, TIMKEN #LM11910	2	
7%#	20465	BEARING, CONE, TIMKEN #LM11949	2	
8%	0627	KEY, SQUARE 3/16 X 1 1/4	1	
9%	1828	GEAR, WORM & SHAFT ASSY.	1	
10%	12874	CASE, GEAR, JA FINISHER	1	
11%	1132	VENT, AIR	1	
12	0655	SCREW, HHC 5/16-18 X 3/4	1	
13	0300B	WASHER, FLAT 5/16 SAE	3	
14%	20476	SCREW, HHC 1/4-28 X 3/8	2	
15%	21033	SIGHT GLASS, 3/4 M PIPE STEEL	1	
16%	0121A	FITTING, PLUG 3/8 MP SQ HEAD	1	
17%	1138	RING, SNAP, TRUARC 5100-112	1	
18%#	20475	BEARING, CUP TIMKEN #M86610	2	
19%#	20474	BEARING, CONE TIMKEN #M86647	2	
20%	1202	GEAR, WORM, BRONZE	1	
21%	20470	SHAFT, OUTPUT JA FIN	1	
22%	1139	KEY, WOODRUFF #21 HARDENED	1	
23	1238	KEY, WOODRUFF #25	1	
24%*	20402	SHIM, OUTPUT 0.002 THICK	1	
	20403	SHIM, OUTPUT 0.003 THICK	1	
	20404	SHIM, OUTPUT 0.005 THICK	1	
	20405	SHIM, OUTPUT 0.010 THICK	1	
	20406	SHIM, OUTPUT 0.020 THICK	1	
25%*	20396	RING, O -257 BUNA N	1	
26%	12875	COVER, GEARBOX	1	
27%	10235	WASHER, C/S EXT. SHKP	4	
28%	1146	SCREW, FHSC 5/16-18 X 1, NYLOC NP	4	
29%*	0254	SEAL, OIL, NATIONAL #470712	1	

# JA-SERIES TROWEL — GEARBOX AND ENGINE MOUNTS ASSY.

## GEARBOX AND ENGINE MOUNTS ASSY.

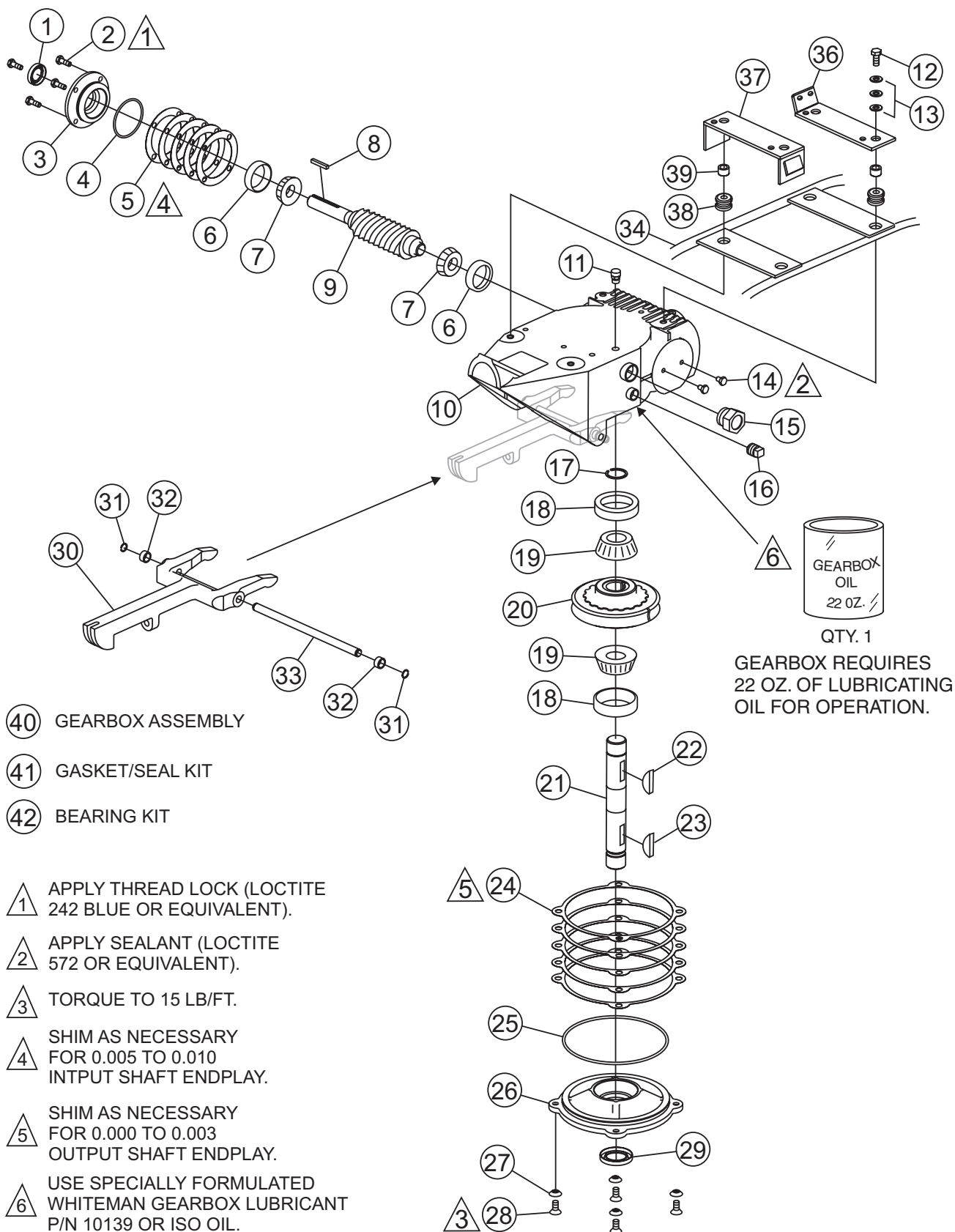

- ④ GEARBOX ASSEMBLY
- ④ GASKET/SEAL KIT
- ④ BEARING KIT

- ① APPLY THREAD LOCK (LOCTITE 242 BLUE OR EQUIVALENT).
- ② APPLY SEALANT (LOCTITE 572 OR EQUIVALENT).
- ③ TORQUE TO 15 LB/FT.
- ④ SHIM AS NECESSARY FOR 0.005 TO 0.010 INPUT SHAFT ENDPLAY.
- ⑤ SHIM AS NECESSARY FOR 0.000 TO 0.003 OUTPUT SHAFT ENDPLAY.
- ⑥ USE SPECIALLY FORMULATED WHITEMAN GEARBOX LUBRICANT P/N 10139 OR ISO OIL.

## JA-SERIES TROWEL — GEARBOX AND ENGINE MOUNTS ASSY.

### GEARBOX AND ENGINE MOUNTS ASSY.

<u>NO.</u>	<u>PART NO.</u>	<u>PART NAME</u>	<u>QTY.</u>	<u>REMARKS</u>
30	1150	ARM, YOKE	1	
31	20802	RING, SNAP, TRUARC 5100-37 OR EQUIV.	2	
32	20803	SPACER, .50 OD X .40 ID X 0.25L	2	
33	20801	PIN, YOKE	1	
34	20796	GUARD RING ASSY., JA	1	
36	1954	FRONT ENGINE MOUNT	1	
37	1942	REAR ENGINE MOUNT	1	
38	1247	GROMMET 1/4 X .875 ID X 1-5/8 OD	4	
39	1245	SPACER, GUARD RING	4	
40	20394	GEARBOX ASSY., JA .....	1 .....	INCLUDES ITEMS W/%
41	21046	GASKET/SEAL KIT. ....	1 .....	INCLUDES ITEMS W/*
42	21047	BEARING KIT KIT. ....	1 .....	INCLUDES ITEMS W/#

# JA-SERIES TROWEL — ENGINES, HONDA, ROBIN, BRIGGS & STRATTON

ENGINES, 5.5 HP HONDA, 6 HP ROBIN, & 5.5 HP BRIGGS AND STRATTON ASSY.

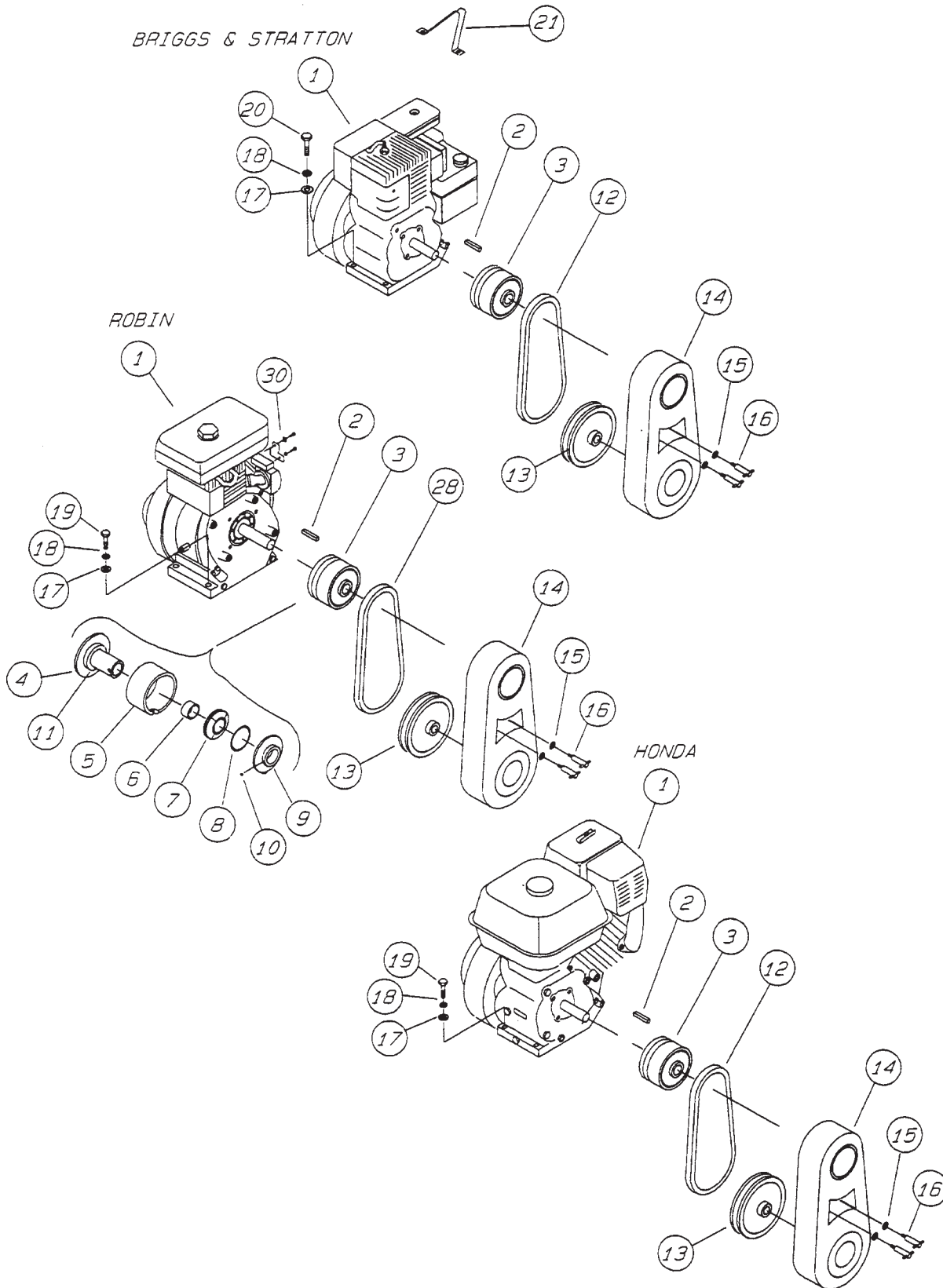

# JA-SERIES TROWEL — ENGINES, HONDA, ROBIN, BRIGGS & STRATTON

ENGINES, 5.5 HP HONDA, 6 HP ROBIN, & 5.5 HP BRIGGS AND STRATTON ASSY.

<u>NO.</u>	<u>PART NO.</u>	<u>PART NAME</u>	<u>QTY.</u>	<u>REMARKS</u>
1	1255	ENGINE 6 HP ROBIN	1	
1	1386	ENGINE 5.5 HP HONDA	1	
1	20468	ENGINE 5.5 HP BRIGGS & STRATTON	1	
2	0310	SQUARE KEY 1/4X1/4X1.1/2"	1	
3	0255	AUTOMATIC CLUTCH ASSY. 1" BORE .....	1 .....	INCLUDES ITEMS W/*
4	0256	SPINDLE 1" BORE	1	
5*	0251	CLUTCH HOUSING DRUM	1	
6*	0458	CLUTCH HOUSING DRUM BUSHING	1	
7*	0454	WEIGHT SET (INCLUDES 4 WEIGHT)	1	
8*	0855	SPRING	1	
9*	0253	CLUTCH EXPANSION PLATE	1	
10*	0457	HSSS 3/8-24X1/2"	1	
11*	0456	BELT RUNNER (BEARING)	1	
12	1390	BELT, (HONDA)	1	
12	1243	BELT, (A27) (BRIGGS & STRATTON)	1	
13	0740	PULLEY	1	
14	D6005	BELT GUARD	1	
15	0181B	LOCK WASHER 1/4"	2	
16	2577	T-BOLT 1/4-20	2	
17	0300B	FLAT WASHER 5/16"	4	
18	0161C	LOCK WASHER 5/16"	4	
19	10181	HHCS 5/16-24 x 1-1/4"	4	
20	1391	HHCS 5/16-24 x 1-1/2"	4	
21		LIFT STRAP .....	1 .....	CONTACT UNIT SALES DEPT. ..... ACCESSORY ITEM
28	1390	BELT, (ROBIN)	1	

# JA-SERIES TROWEL — HAND CLUTCH ASSY.

HAND CLUTCH ASSY.

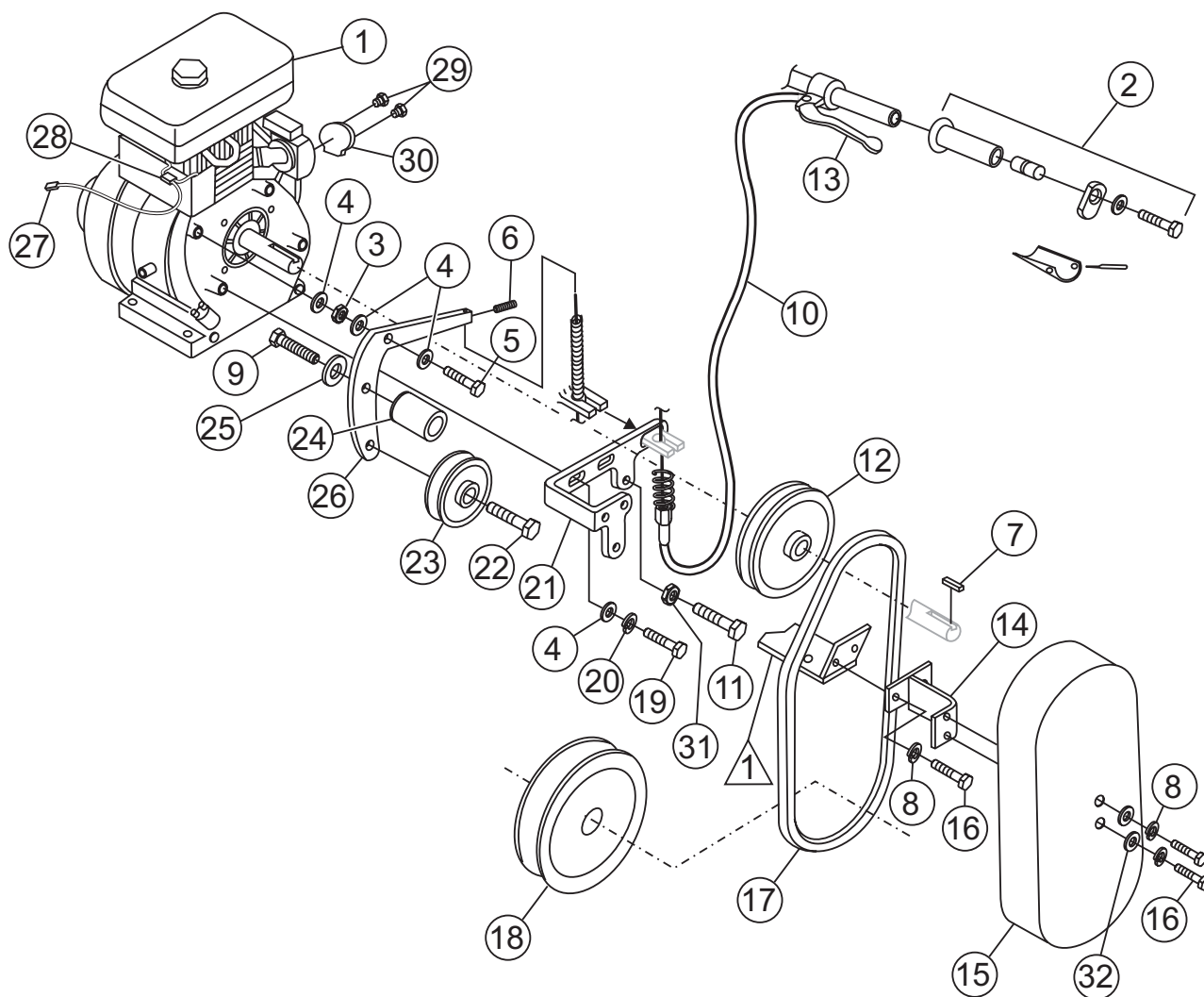

△ SEE GEARBOX AND ENGINE MOUNTS ITEM 36 PAGE 52.

## JA-SERIES TROWEL — HAND CLUTCH ASSY.

### HAND CLUTCH ASSY.

<u>NO.</u>	<u>PART NO.</u>	<u>PART NAME</u>	<u>QTY.</u>	<u>REMARKS</u>
1	1386	ENGINE 5.5 HP HONDA	1	
1	1255	ENGINE 6 HP ROBIN	1	
2	10036	CLUTCH ASSIST HANDLE ASSY.	1	
3	6014C	HEX FINISH NUT 5/16-24	1	
4	0300B	FLAT WASHER 5/16"	5	
5	10181	HHC 5/16-24 X1.1/4"	1	
6	10450	SHSS 10-32 X1/4"	1	
7	0627	KEY, SQUARE 3/16 X 1.1/4"	1	
8	0181B	LOCK WASHER 1/4"	4	
9	1672	SCREW, HHC 3/8-24 x 1"	1	
10	10936	HAND CLUTCH CABLE ASSY.	1	
11	4538	SCREW, HHC 1/4-20 X 2.1/2" GR5	1	
12	11043	PULLEY, AK41 X 3/4	1	
13	1512	HAND CLUTCH CONTROL LEVER	1	
14	10831	BELT GUARD MOUNT	1	
15	11046	BELT GUARD	1	
16	0730	HHCS 1/4-20 X1"	4	
17	0152-3	BELT, A28 GATES HPII	1	
18	11049	PULLEY, DRIVEN (HONDA)	1	
18	0740	PULLEY, DRIVEN (ROBIN)	1	
19	10229	HHCS 5/16-24 X1"	2	
20	0161C	LOCK WASHER 5/16"	2	
21	10897	CLUTCH BRACKET	1	
22	1284	SCREW, HHC 3/8-16 X1.1/2"	1	
23	10935	PULLEY, IDLER	1	
24	20981	SHOE, BELT HAND CLUTCH	1	
25	13351	WASHER, FLAT 3/8 USS EX THK HI-STR	1	
26	20977	LEVER, CLUTCH JA-M	1	
27	1488	WIRE, SAFETY SWITCH	1	
28	1475	CNCTR, SPLICE TAP	1	
29	1273	SCREW, HHST 8-32 X 3/8	2	
30	1834	DEFLECTOR, HONDA EXHAUST	1	
31	0949	NUT, HEX FIN 1/4-20 PLTD	1	
32	0948	WASHER, FLAT 1/4 SAE	2	

# JA-SERIES TROWEL — GUARD RING ASSY.

GUARD RING ASSY.

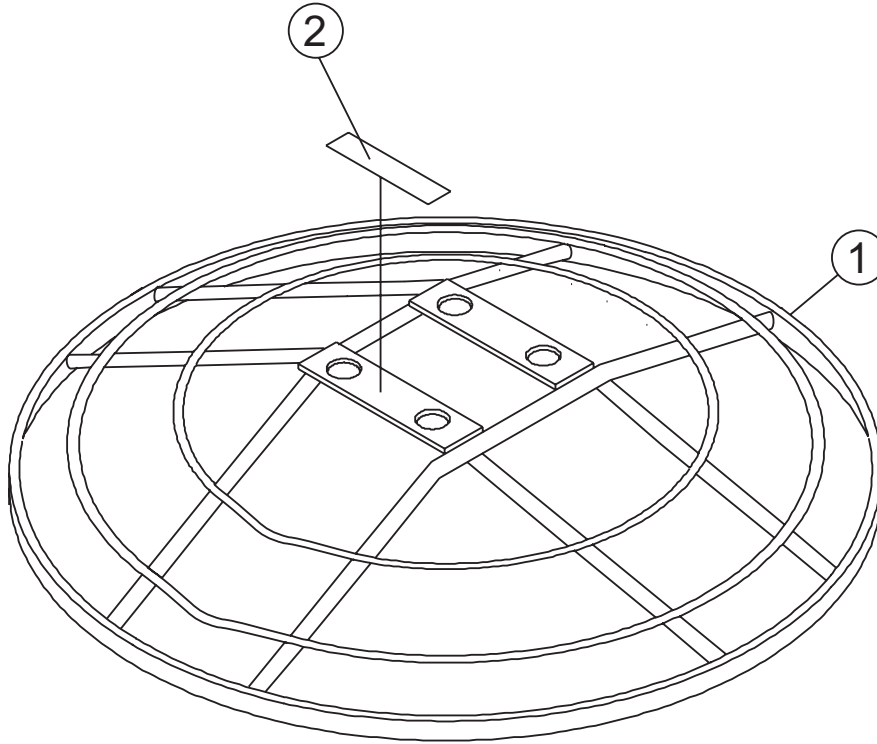

# JA-SERIES TROWEL — GUARD RING ASSY.

## GUARD RING ASSY.

<u>NO.</u>	<u>PART NO.</u>	<u>PART NAME</u>	<u>QTY.</u>	<u>REMARKS</u>
1	20796	STATIONARY GUARD RING	1	
2	1489	SPIDER PLATE ASSY 16-1/2" ARM (EXT) .....	1	..... 3-BLADE MODEL
2	1490	SPIDER PLATE ASSY 16-1/2" ARM (EXT) .....	1	..... 4-BLADE MODEL

# JA-SERIES TROWEL — BLADES & ADJUSTMENT FIXTURE ASSY.

## BLADES & ADJUSTMENT FIXTURE ASSY.

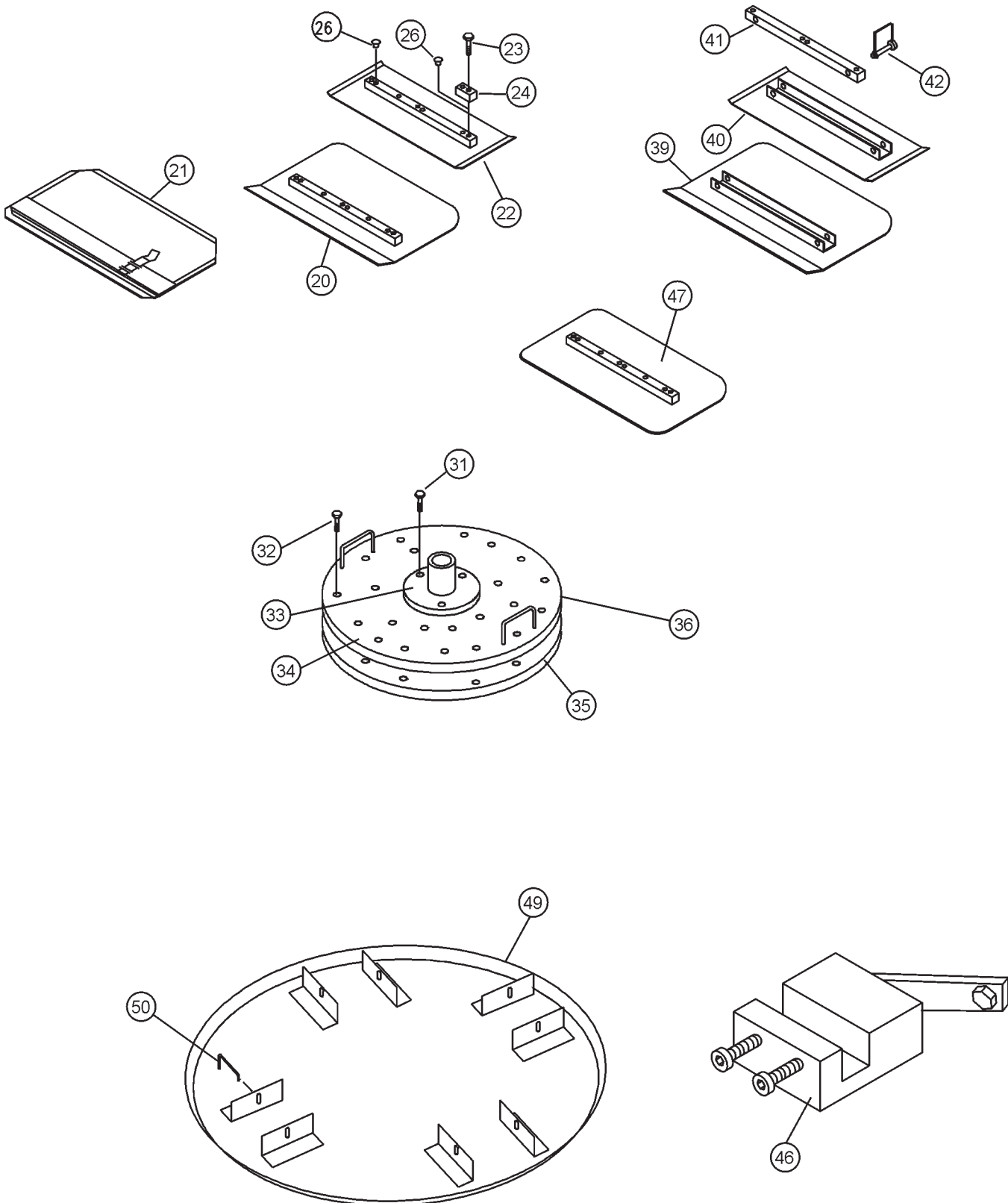

# JA-SERIES TROWEL — BLADES & ADJUSTMENT FIXTURE ASSY.

## BLADES & ADJUSTMENT FIXTURE ASSY.

<u>NO.</u>	<u>PART NO.</u>	<u>PART NAME</u>	<u>QTY.</u>	<u>REMARKS</u>
20		COMBO FLOAT & FINISH BLADE .....	3,4	CONTACT UNIT SALES DEPT./ACCESSORY ITEM
20		ENDURO COMBO FLOAT &FINISH BLADE .....	3,4	CONTACT UNIT SALES DEPT./ACCESSORY ITEM
21		FLOAT BLADE .....	3,4	CONTACT UNIT SALES DEPT./ACCESSORY ITEM
22		FINISH BLADE .....	3,4	CONTACT UNIT SALES DEPT./ACCESSORY ITEM
22		ENDURO FINISH BLADE W/ROTATING .....	3,4	CONTACT UNIT SALES DEPT./ACCESSORY ITEM
23	0202	HHCS 5/16-18X1" RING	3,4	
24	0201	GUARD RING LUG RING	3,4	
26	1434	TROWEL LUG (FINISH BLADE ONLY)	3,4	
30	1237	HHCS 5/16-18X7/8" NY-LOC	3,4	
31	0490	SHCS 7/16-14X1"	3	
32	0487	SHCS 3/8-16X1/2"	20	
33	0489	GRINDING DISC HUB	1	
34	0488	STONE MOUNT PLATE	1	
35		GRINDING DISC STONE ONLY .....	1	CONTACT UNIT SALES DEPT./ACCESSORY ITEM
36		GRINDING DISC ASSY. ....	1	CONTACT UNIT SALES DEPT./ACCESSORY ITEM
39		UNIVERSAL COMBO BLADE .....	3,4	CONTACT UNIT SALES DEPT./ACCESSORY ITEM
39		ENDURO UNIVERSAL COMBO BLADE .....	3,4	CONTACT UNIT SALES DEPT./ACCESSORY ITEM
40		UNIVERSAL FINISH BLADE .....	3,4	CONTACT UNIT SALES DEPT./ACCESSORY ITEM
40		ENDURO UNIVERSAL FINISH BLADE .....	3,4	CONTACT UNIT SALES DEPT./ACCESSORY ITEM
41		UNIVERSAL MOUNTING JAR .....	3,4	CONTACT UNIT SALES DEPT./ACCESSORY ITEM
42		SNAP PIN 1/4"X1.3/4" .....	6,8	CONTACT UNIT SALES DEPT./ACCESSORY ITEM
46		TROWEL ARM ADJ. FIXTURE ASSY. ....	1	CONTACT UNIT SALES DEPT./ACCESSORY ITEM
47		REVERSIBLE COMBO BLADE .....	3,4	CONTACT UNIT SALES DEPT./ACCESSORY ITEM
49		FLOAT DISC .....	1	CONTACT UNIT SALES DEPT./ACCESSORY ITEM
50		FLOAT DISC LATCH PIN .....	4	CONTACT UNIT SALES DEPT./ACCESSORY ITEM

# JA-SERIES TROWEL — LIFTING BALE ASSY. (OPTION)

LIFTING BALE ASSY. (OPTION)

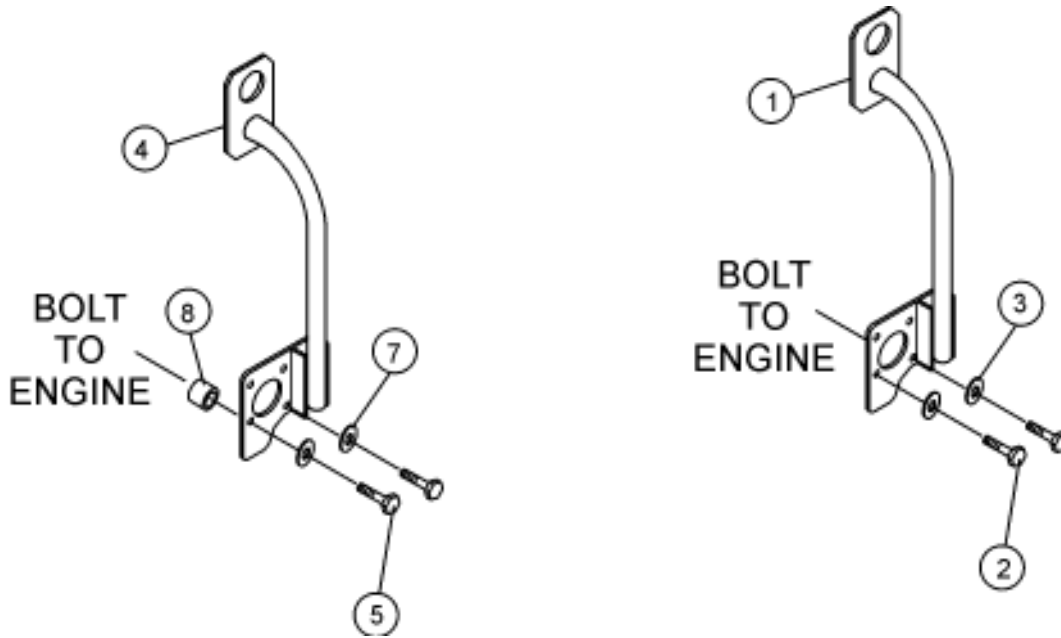

## JA-SERIES TROWEL — LIFTING BALE ASSY. (OPTION)

### LIFTING BALE ASSY. (OPTION)

<u>NO.</u>	<u>PART NO.</u>	<u>PART NAME</u>	<u>QTY.</u>	<u>REMARKS</u>
1		LIFTING BALE ASSY. ....	1	CONTACT UNIT SALES DEPT./ACC. ITEM
2	10229	HHCS 5/16-24X1"	4	
3	0161C	LOCK WASHER 5/16"	4	
4		LIFTING BALE ASSY. ....	1	CONTACT UNIT SALES DEPT./ACC. ITEM
5	0205	HHCS 3/8-16X1"	3	
7	0166A	LOCK WASHER 3/8"	3	
8	1897	SPACER (ROBIN ENGINE)	4	

# HONDA GX160K1QA2 ENGINE — CYLINDER HEAD ASSY.

CYLINDER HEAD ASSY.

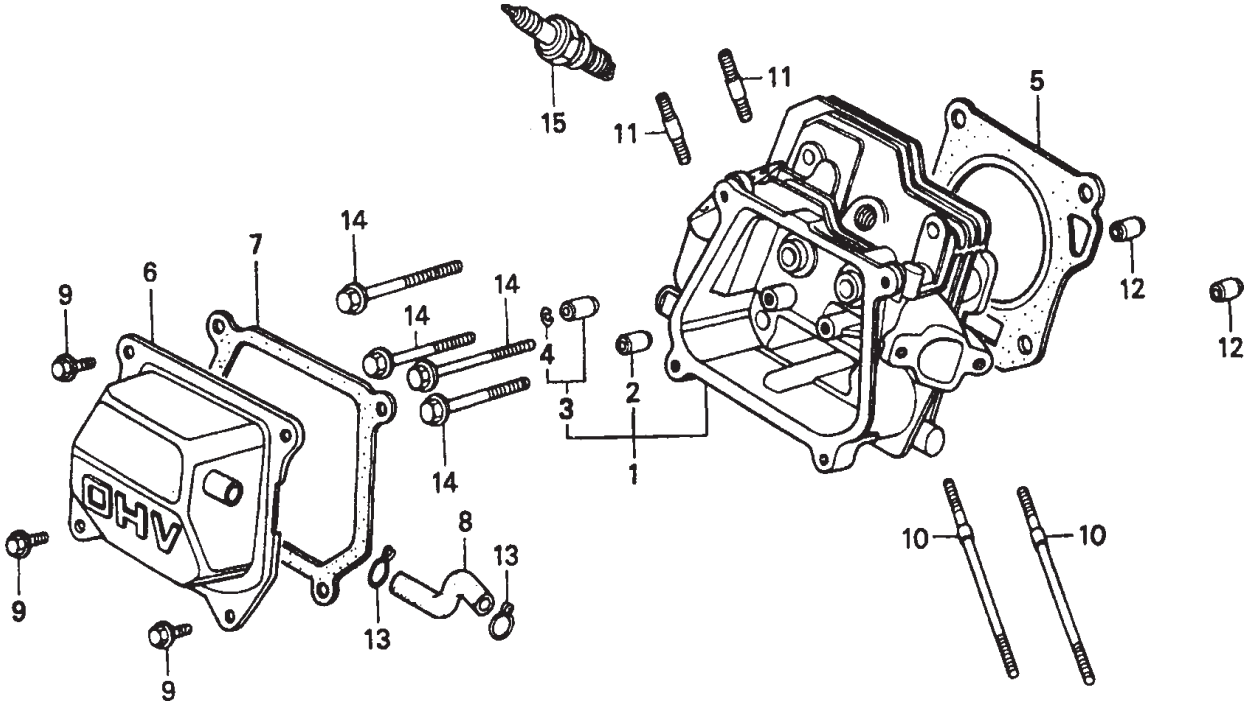

# HONDA GX160K1QA2 ENGINE — CYLINDER HEAD ASSY.

## CYLINDER HEAD ASSY.

<b>NO</b>	<b>PART NO</b>	<b>PART NAME</b>	<b>QTY.</b>	<b>REMARKS</b>
1	12210ZH8000	CYLINDER HEAD, COMP .....	1	INCLUDES ITEMS W/*
2*	12204ZE1306	GUIDE, IN. VALVE (OVER SIZE)	1	
3*	12205ZE1315	GUIDE, EX. VALVE (OS)	1	
4	12216ZE5300	CLIP, VALVE GUIDE	1	
5	12251ZF1800	GASKET, CYLINDER HEAD	1	
6	12310ZE1010	COVER COMP, HEAD	1	
7	12391ZE1000	GASKET, CYLINDER HEAD COVER	1	
8	15721ZH8000	TUBE, BREATHER	1	
9	90016ZE1000	BOLT, FLANGE 6X13	4	
10	90043ZE1020	BOLT, STUD 6X109	2	
11	90047ZE1000	BOLT, STUD 8X32	2	
12	9430110160	PIN A, DOWEL 10X16	2	
14	957230806000	BOLT, FLANGE 8X60	4	
15	9807956846	PLUG, SPARK (BPR6ES NGK)	1	
	9807956855	PLUG, SPARK (W20EPR-U ND)	1	

# HONDA GX160K1QA2 ENGINE — CYLINDER BARREL ASSY.

CYLINDER BARREL ASSY.

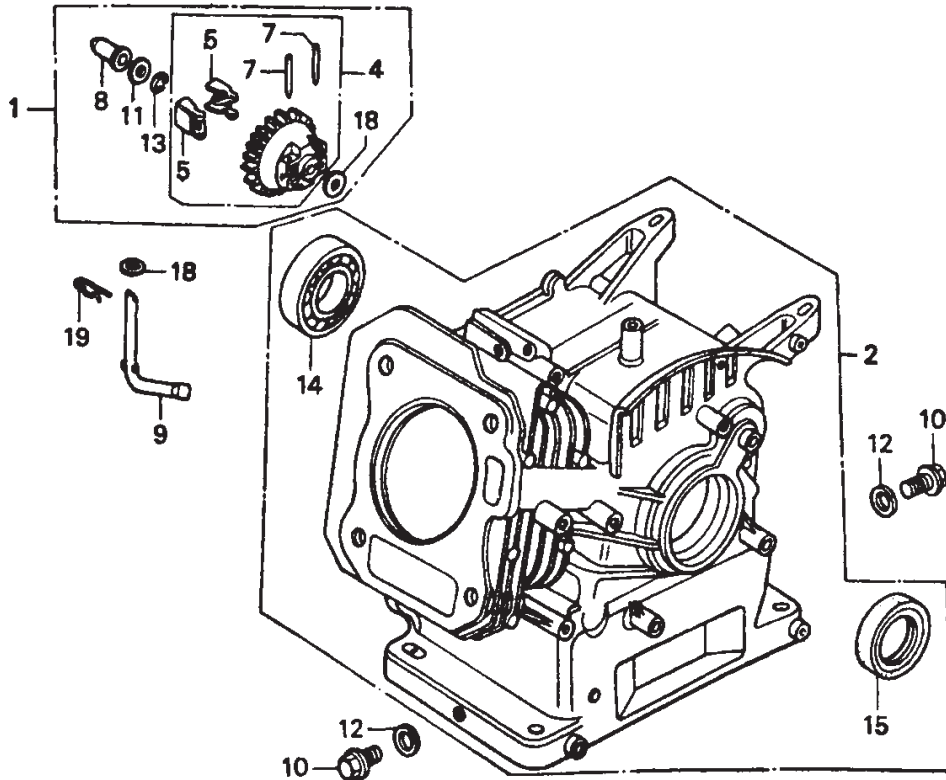

# HONDA GX160K1QA2 ENGINE — CYLINDER BARREL ASSY.

## CYLINDER BARREL ASSY.

<u>NO</u>	<u>PART NO</u>	<u>PART NAME</u>	<u>QTY.</u>	<u>REMARKS</u>
1	06165ZE1000	GOVERNOR KIT .....	1 .....	INCLUDES ITEMS W/*
2	12000ZH8010	CYLINDER BARREL ASSY. ....	1 .....	INCLUDES ITEMS W%
4*	16510ZE1000	GOVERNOR ASSY. ....	1 .....	INCLUDES ITEMS/W#
5*#	16511ZE1000	WEIGHT, GOVERNOR	2	
7*#	16513ZE1000	PIN, GOVERNOR WEIGHT	2	
8*	16531ZE1000	SLIDER, GOVERNOR	1	
9	16541ZE1000	SHAFT, GOVERNOR ARM	1	
10	90131ZE1000	BOLT, DRAIN PLUG	2	
11*	90451ZE1000	WASHER, THRUST 6MM	1	
12	90601ZE1000	WASHER, DRAIN PLUG 10.2MM	2	
13*	90602ZE1000	CLIP, GOVERNOR HOLDER	1	
14%	91001ZF1003	BEARING, RADIAL BALL (6205)	1	
15%	91202883005	OIL SEAL 25X41X6	1	
18*	9410106800	WASHER, PLAIN, 6MM	2	
19	9425108000	PIN, LOCK, 8MM	1	

# HONDA GX160K1QA2 ENGINE — CRANKCASE COVER ASSY.

CRANKCASE COVER ASSY.

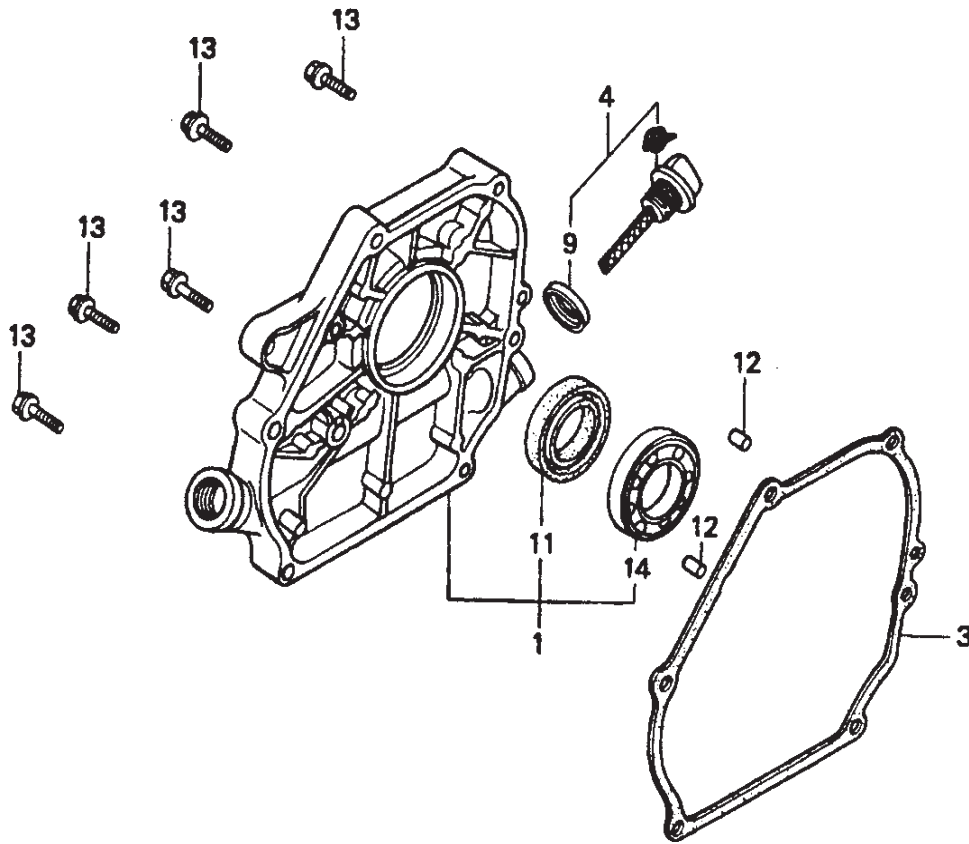

# HONDA GX160K1QA2 ENGINE — CRANKCASE COVER ASSY.

## CRANKCASE COVER ASSY.

<u>NO</u>	<u>PART NO</u>	<u>PART NAME</u>	<u>QTY.</u>	<u>REMARKS</u>
1	11300ZE1641	COVER ASSY, CRANKCASE (U TYPE) .....	1	INCLUDES ITEMS W/*
3	11381ZH8801	GASKET CASE COVER	1	
4	15600ZE1003	CAP ASSY, OIL FILLER	1	INCLUDES ITEMS W/#
5	15600ZG4003	CAP ASSY, OIL FILLER .....	1	INCLUDES ITEMS W/%
7	15620ZG4910	CAP, OIL FILLER	1	
8	15621896010	GASKET, OIL FILLER CAP	1	
9#	15625ZE1000	GASKET, OIL FILLER CAP	1	
10%	15625ZE1003	GASKET, OIL FILLER CAP	1	
11*	91202883005	OIL SEAL, 25X41X6	1	
12	9430108140	PIN A, DOWEL 8X14	2	
13	957010803200	BOLT, FLANGE 8X32	6	
14*	961006205010	BEARING, RADIAL BALL, 6205	1	

# HONDA GX160K1QA2 ENGINE — CRANKSHAFT ASSY.

CRANKSHAFT ASSY.

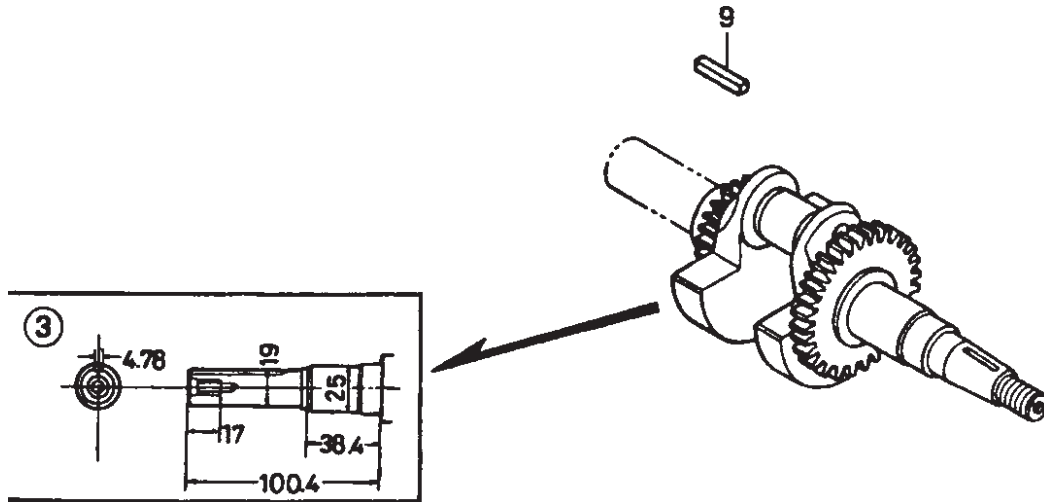

# HONDA GX160K1QA2 ENGINE — CRANKSHAFT ASSY.

## CRANKSHAFT ASSY.

<u>NO</u>	<u>PART NO</u>	<u>PART NAME</u>	<u>QTY.</u>	<u>REMARKS</u>
3	13310ZE1601	CRANKSHAFT COMP.,(Q TYPE)	1	
9	90745ZE1600	KEY (4.78X4.78X38)	1	

# HONDA GX160K1QA2 ENGINE — PISTON RINGS ASSY.

PISTON ASSY.

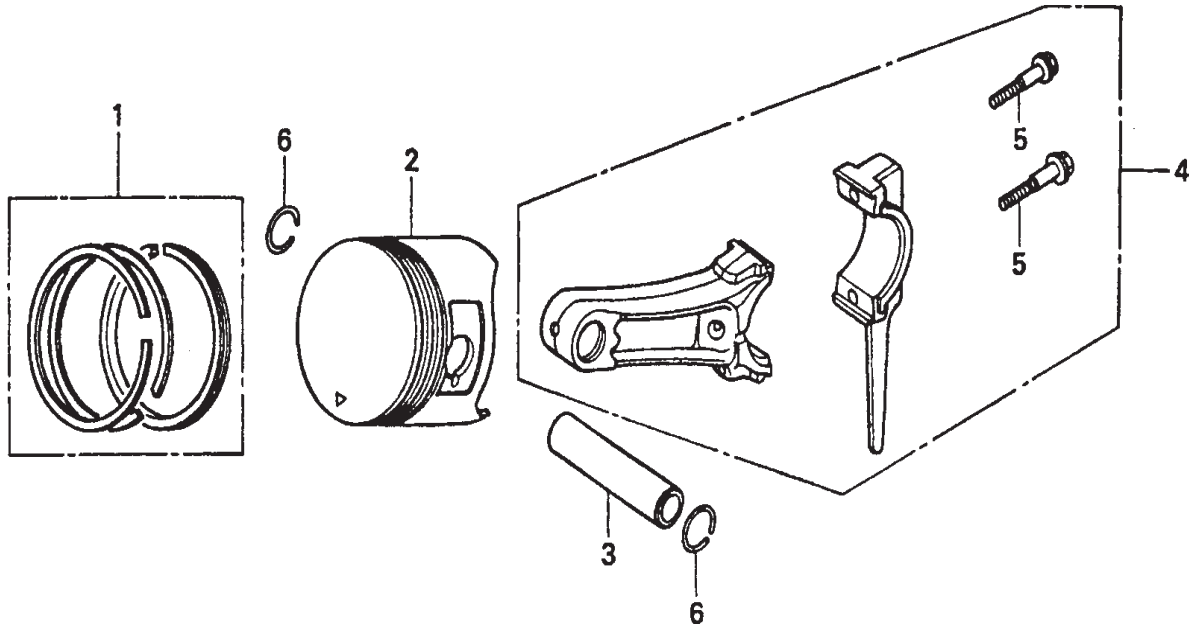

# HONDA GX160K1QA2 ENGINE — PISTON RINGS ASSY.

## PISTON RINGS ASSY.

<u>NO</u>	<u>PART NO</u>	<u>PART NAME</u>	<u>QTY.</u>	<u>REMARKS</u>
1	13010ZF1023	RING SET, PISTON (STD)	1	
	13011ZF1023	RING SET, PISTON (0.25)	1	
	13012ZF1023	RING SET, PISTON (0.50)	1	
	13013ZF1023	RING SET, PISTON (0.75)	1	
2	13101ZH8000	PISTON (STD)	1	
	13102ZH8000	PISTON (0.25)	1	
	13103ZH8000	PISTON (0.50)	1	
	13104ZH8000	PISTON (0.75)	1	
3	13111ZE1000	PIN, PISTON	1	
4	132A0ZE1000	ROD ASSY, CONNECTING .....	1	INCLUDES ITEMS W/*
5*	90001ZE1000	BOLT, CONNECTING ROD	2	
6	90551ZE1000	CLIP, PISTON PIN, 18MM	2	

# HONDA GX160K1QA2 ENGINE — CAMSHAFT ASSY.

CAMSHAFT ASSY.

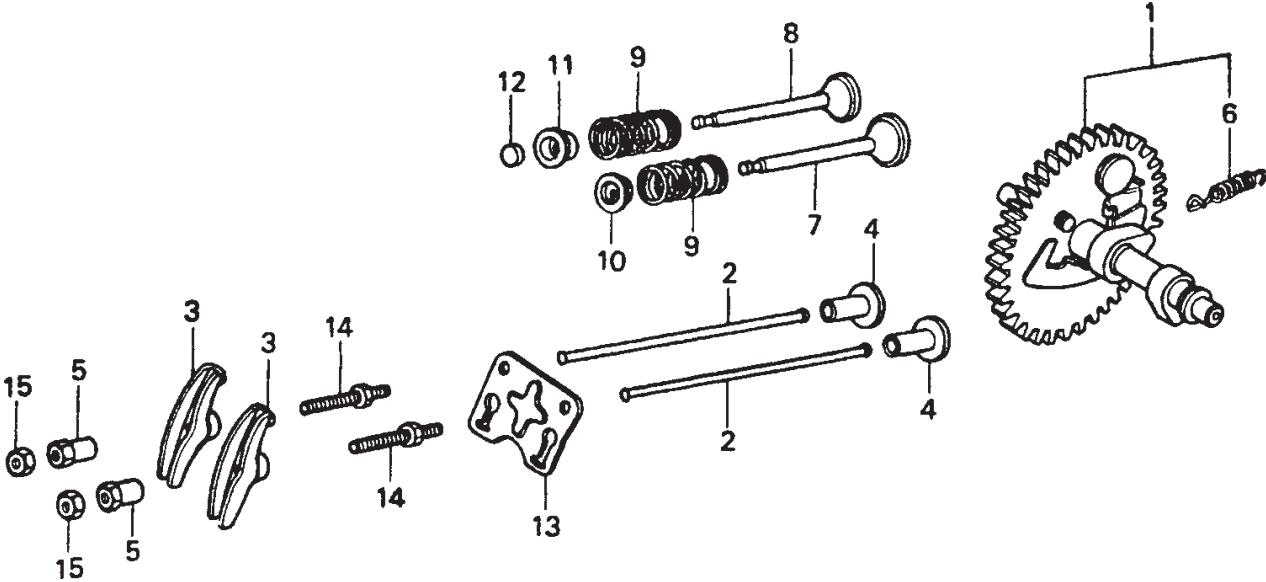

# HONDA GX160K1QA2 ENGINE — CAMSHAFT ASSY.

## CAMSHAFT ASSY.

<u>NO</u>	<u>PART NO</u>	<u>PART NAME</u>	<u>QTY.</u>	<u>REMARKS</u>
1	14100ZE1812	CAMPSHAFT ASSY.....	1	INCLUDES ITEMS W/*
2	14410ZE1010	ROD, PUSH	2	
3	14431ZE1000	ARM, VALVE ROCKER	2	
4	14441ZE1010	LIFTER, VALVE	2	
5	14451ZE1013	PIVOT, ROCKER ARM	2	
6*	14568ZE1000	SPRING, WEIGHT RETURN	1	
7	14711ZF1000	VALVE, IN.	1	
8	14721ZF1000	VALVE, EX.	1	
9	14751ZF1000	SPRING, VALVE	2	
10	14771ZE1000	RETAINER, IN. VALVE SPRING	1	
11	14773ZE1000	RETAINER, EX. VALVE SPRING	1	
12	14781ZE1000	ROTATOR, VALVE	1	
13	14791ZE1010	PLATE, PUSH ROD GUIDE	1	
14	90012ZE0010	BOLT, PIVOT	2	
15	90206ZE1000	NUT, PIVOT ADJUSTING	2	

# HONDA GX160K1QA2 ENGINE — RECOIL STARTER ASSY.

RECOIL STARTER ASSY.

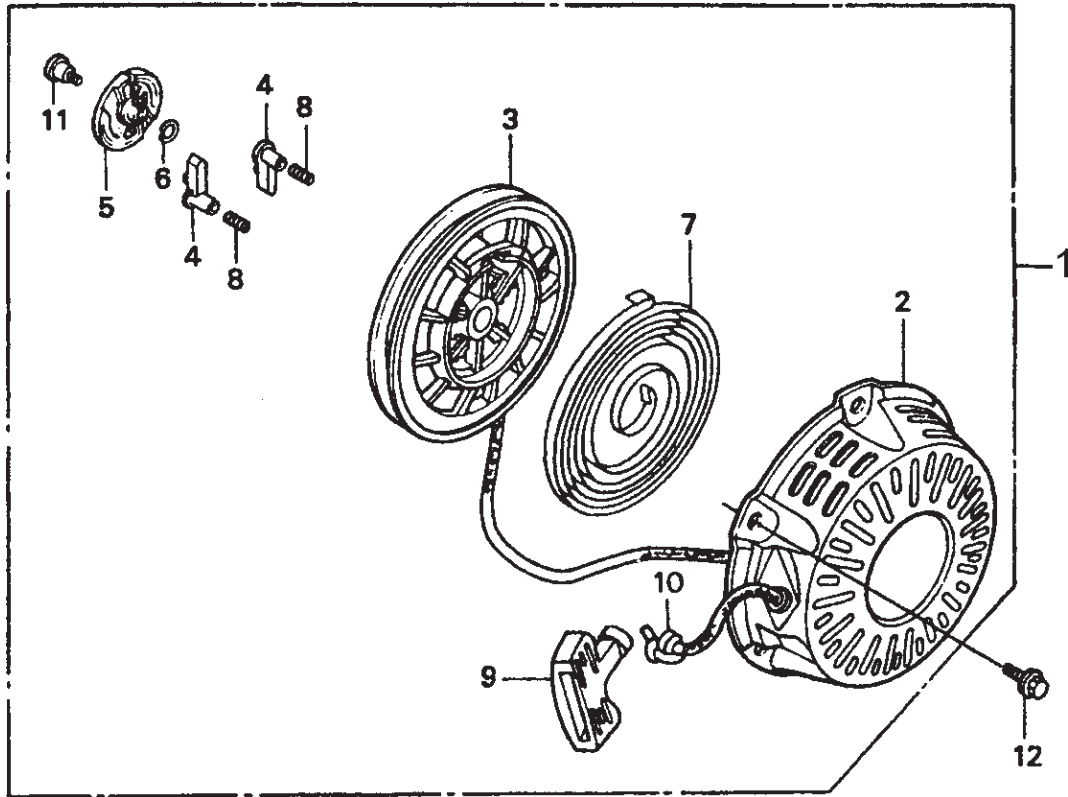

# HONDA GX160K1QA2 ENGINE — RECOIL STARTER ASSY.

## RECOIL STARTER ASSY.

<u>NO</u>	<u>PART NO</u>	<u>PART NAME</u>	<u>QTY.</u>	<u>REMARKS</u>
1	28400ZH8013ZB	STARTER ASSY, RECOIL NH1(BLACK)	1	INCLUDES ITEMS W/*
2*	28410ZH8003ZB	CASE COMP., RECOIL STARTER	1	
3*	28420ZH8013	REEL, RECOIL STARTER	1	
4*	28422ZH8013	RATCHET, STARTER	2	
5*	28433ZH8003	GUIDE, RATCHET	1	
6*	28441ZH8003	SPRING, FRICTION	1	
7*	28442ZH8003	SPRING, RECOIL STARTER	1	
8*	28443ZH8003	SPRING, RETURN	2	
9*	28461ZH8003	KNOB, RECOIL STARTER	1	
10*	28462ZH8003	ROPE, RECOIL STARTER	1	
11*	90003ZH8003	SCREW, SETTING	1	
12	957010600800	BOLT, FLANGE 6X8	3	

# HONDA GX160K1QA2 ENGINE — FAN COVER ASSY.

FAN COVER ASSY.

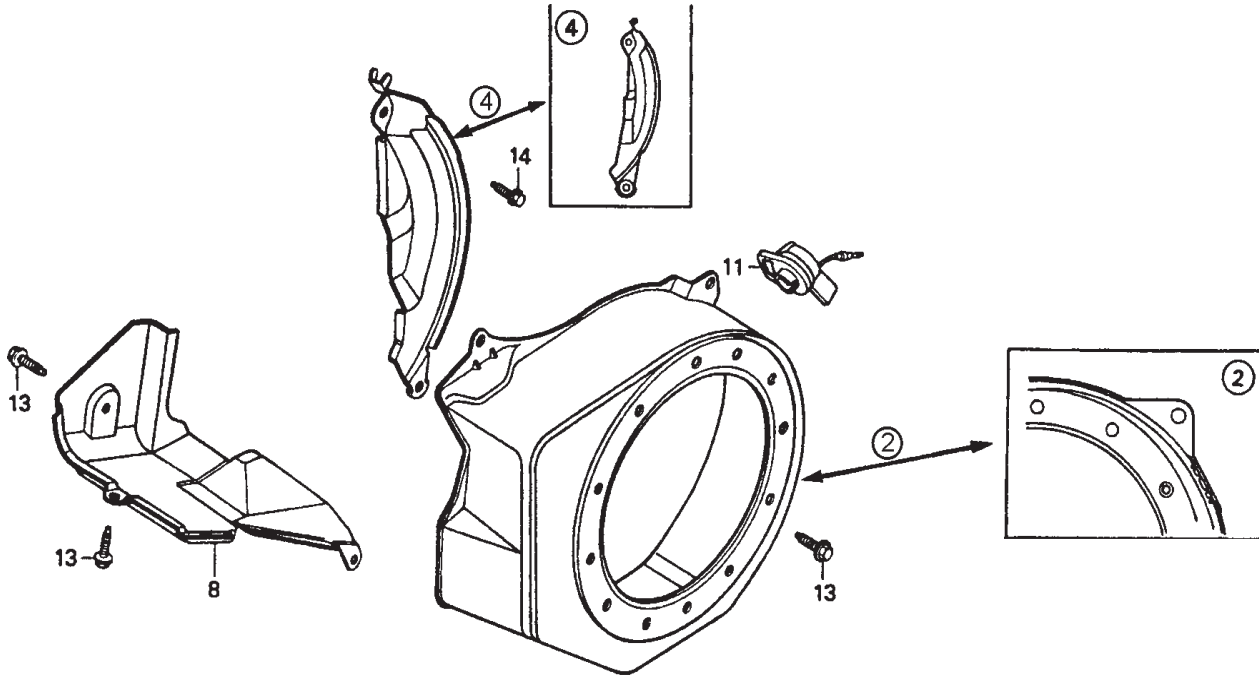

# HONDA GX160K1QA2 ENGINE — FAN COVER ASSY.

## FAN COVER ASSY.

<u>NO</u>	<u>PART NO</u>	<u>PART NAME</u>	<u>QTY.</u>	<u>REMARKS</u>
2	19610ZE1000ZC	COVER COMP., FAN NH1(BLACK)	1	
4	19612ZH8000	PLATE, SIDE(STD)	1	
8	19630ZH8000	SHROUD COMP.	1	
11	36100ZE1015	SWITCH ASSY., ENGINE	1	
13	90013883000	BOLT, FLANGE 6X12	6	
14	90022888010	BOLT, FLANGE 6X20	1	

# HONDA GX160K1QA2 ENGINE — CARBURETOR ASSY.

CARBURETOR ASSY.

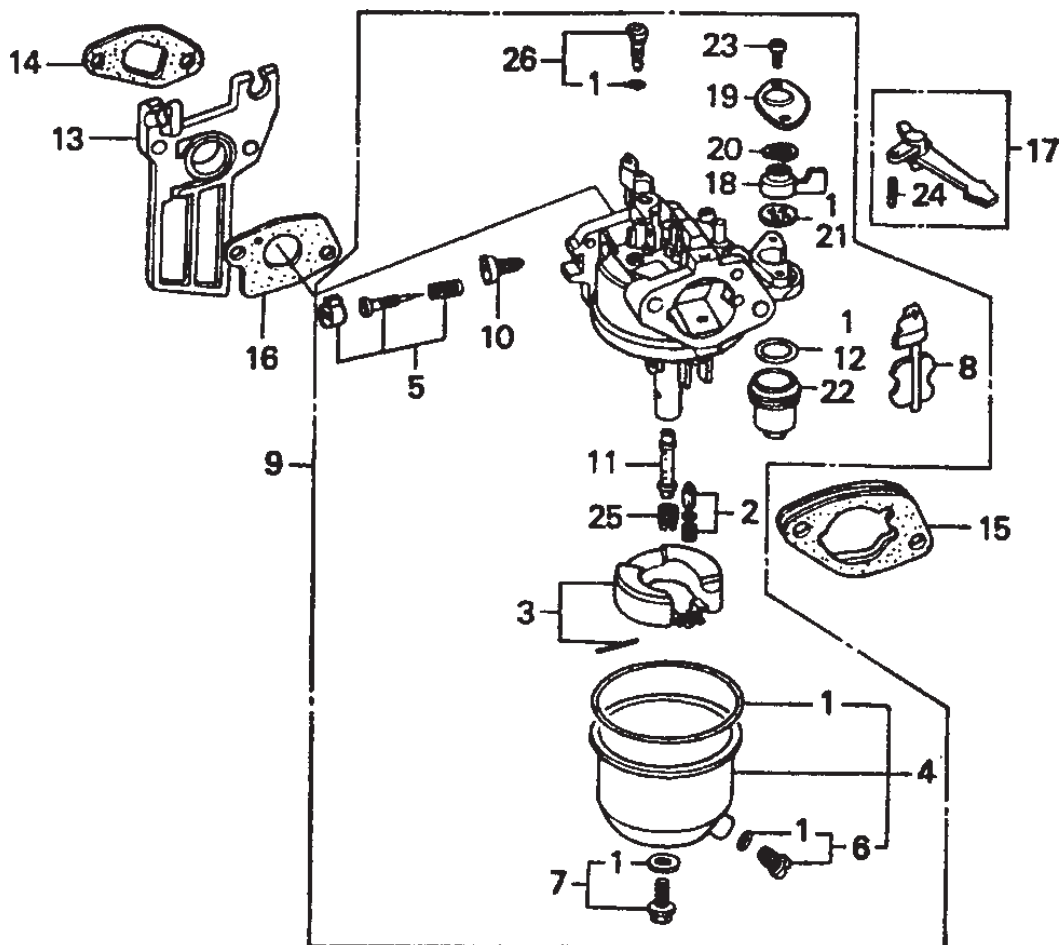

# HONDA GX160K1QA2 ENGINE — CARBURETOR ASSY.

## CARBURETOR ASSY.

<u>NO</u>	<u>PART NO</u>	<u>PART NAME</u>	<u>QTY.</u>	<u>REMARKS</u>
1*	16010ZE1812	GASKET SET	1	
2*	16011ZE0005	VALVE SET, FLOAT	1	
3*	16013ZE0005	FLOAT SET	1	
4*	16015ZE0831	CHAMBER SET, FLOAT .....	1	INCLUDES ITEMS W/%
5*	16016ZH7W01	SCREW SET	1	
6*%	16024ZE1811	SCREW SET DRAIN	1	
7*	16028ZE0005	SCREW SET B	1	
8*	16044ZE0005	CHOKE SET	1	
9	16100ZH8W61	CARBURETOR ASSY(BE65C B) .....	1	INCLUDES ITEMS W/*
10*	16124ZE0005	SCREW, THROTTLE STOP	1	
11*	16166ZH8W60	NOZZLE, MAIN	1	
12*	16955283000	GASKET, FULL STRAINER CUP	1	
13	162111ZE1000	INSULATOR CARBURETOR	1	
14	16212ZH8800	GASKET, INSULATOR	1	
15	16220ZE1020	SPACER COMP. CARBURETOR	1	
16	16221ZH8801	GASKET CARBURETOR	1	
17	16610ZE1000	LEVER COMP., CHOKE (STD) .....	1	INCLUDES ITEMS W/#
18*	16953ZE1406	LEVER VALVE	1	
19*	16954ZE1812	PLATE LEVER SETTING	1	
20*	16956ZE1811	SPRING, PETCOCK LEVER	1	
21*	16957ZE1812	GASKET, PETCOCK	1	
22*	16967ZE0811	CUP, FUEL STRAINER	1	
23*	93500030060H	SCREW, PAN 3X6	2	
24#	9430520122	PIN, SPRING 2X12	1	
25*	99101ZH70650	JET, MAIN #65	1	
	99101ZH70680	JET, MAIN #68	1	
	99101ZH70700	JET, MAIN #70	1	
26*	99204ZE00350	JET SET, PILOT #35	1	

# HONDA GX160K1QA2 ENGINE — AIR CLEANER ( OIL BATH ) ASSY.

AIR CLEANER (OIL BATH ) ASSY.

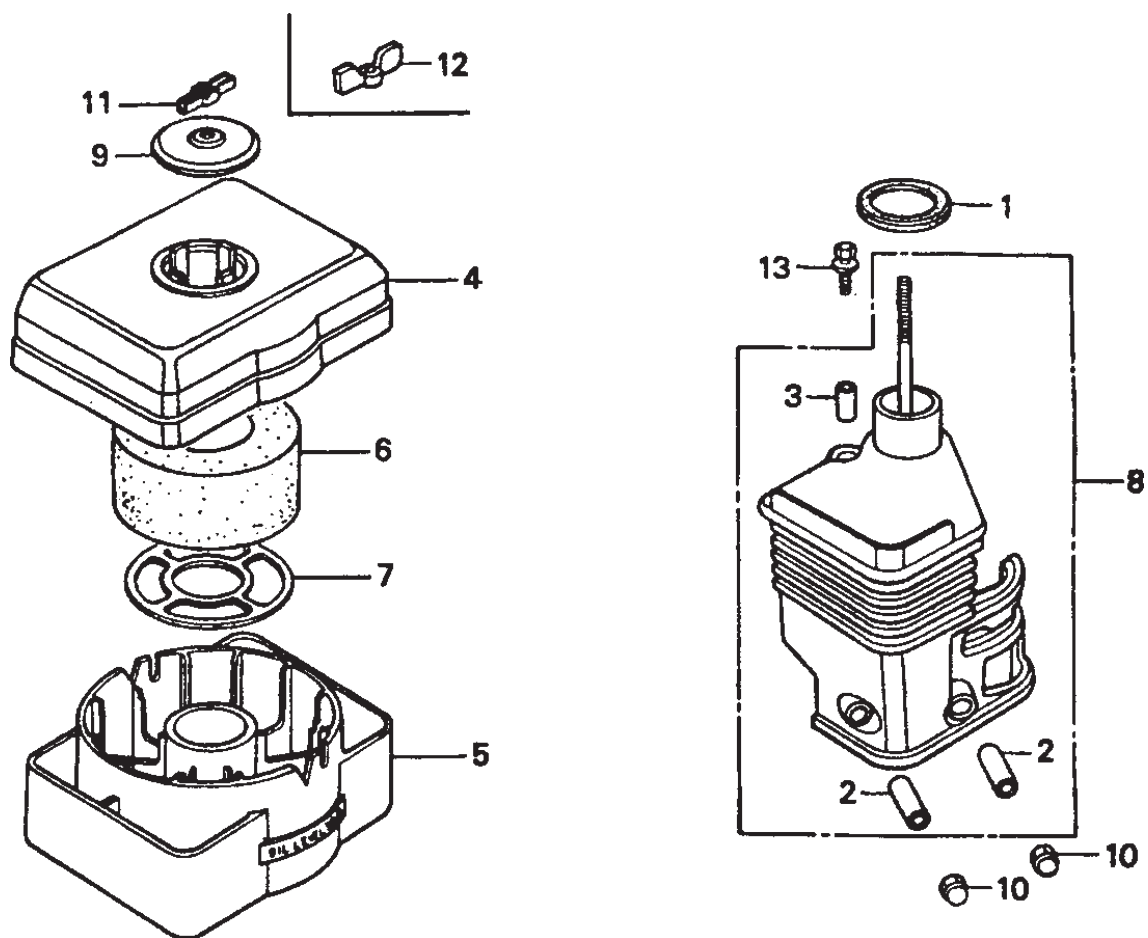

# HONDA GX160K1QA2 ENGINE — AIR CLEANER ( OIL BATH ) ASSY.

## AIR CLEANER ( OIL BATH ) ASSY.

<u>NO</u>	<u>PART NO</u>	<u>PART NAME</u>	<u>QTY.</u>	<u>REMARKS</u>
1	16271ZE1000	GASKET ELBOW	1	
2*	17238ZE7010	COLLAR AIR CLEANER	2	
3*	17239ZE1000	COLLAR B AIR CLEANER	1	
4	17401ZE1810	BODY CLEANER OIL BATH	1	
5	17402ZE1810	PAN CLEANER OIL OIL BATH	1	
6	17403ZE1810	AIR CLEANER ELEMENT OIL BATH	1	
7	17404841000	GRID AIR CLEANER	1	
8	17410ZE1020	ELBOW COMP. AIR CLEANER .....	1	..... INCLUDES ITEMS W/*
9	17421ZE1000	CAP CLEANER	1	
10	90201415000	NUT CAP 6MM	2	
12	90325044000	NUT WING TOOL BOX SETTING	1	
13	957010602000	BOLT FLANGE 6 x 20	1	

# HONDA GX160K1 ENGINE — MUFFLER ASSY.

MUFFLER ASSY.

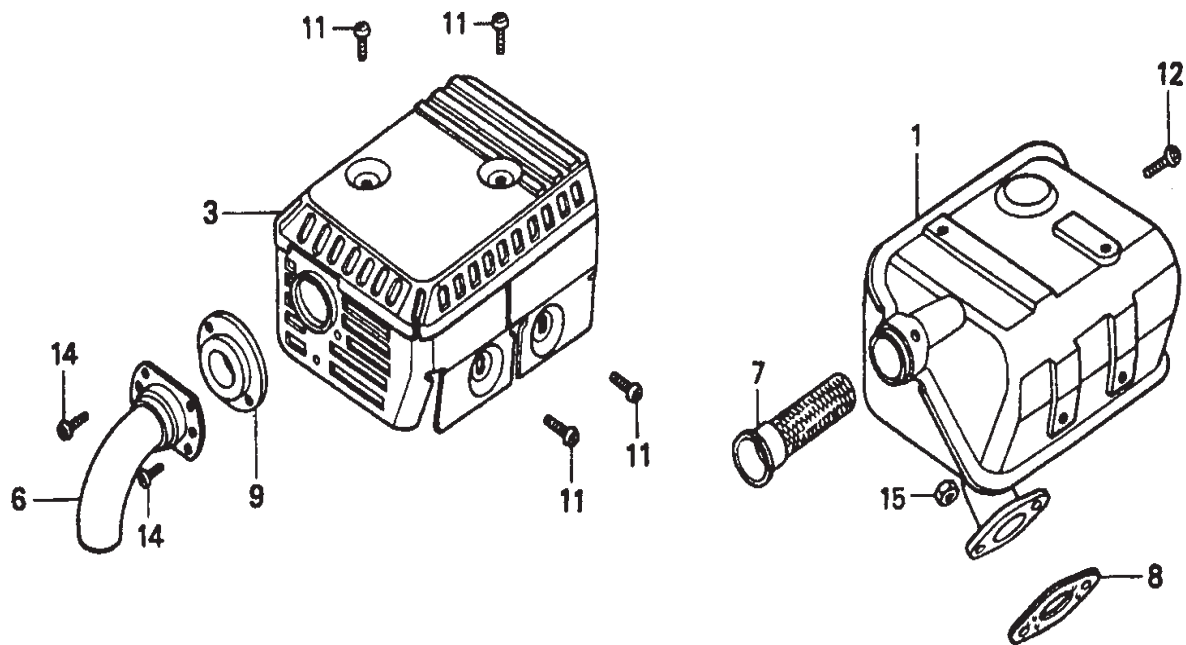

# HONDA GX160K1 ENGINE — MUFFLER ASSY.

## MUFFLER ASSY.

<u>NO</u>	<u>PART NO</u>	<u>PART NAME</u>	<u>QTY.</u>	<u>REMARKS</u>
1	18310ZH8810	MUFFLER COMP.	1	
3	18320ZF1H01	PROTECTOR, MUFFLER	1	
6	18340ZE1010	DEFLECTOR COMP.	1	
7	18355ZE1000	ARRESTER, SPARK	1	
8	18381ZH8800	GASKET, MUFFLER	1	
9	18522ZE1000	GUIDE, MUFFLER	1	
11	90050ZE1000	SCREW, TAPPING 5X8	4	
12	90055ZE1000	SCREW, TAPPING 4X6	1	
14	90183671003	SCREW, TAPPING 4X8	2	
15	94001080000S	NUT, HEX (8MM)	2	

# HONDA GX160K1QA2 ENGINE — FUEL TANK ASSY.

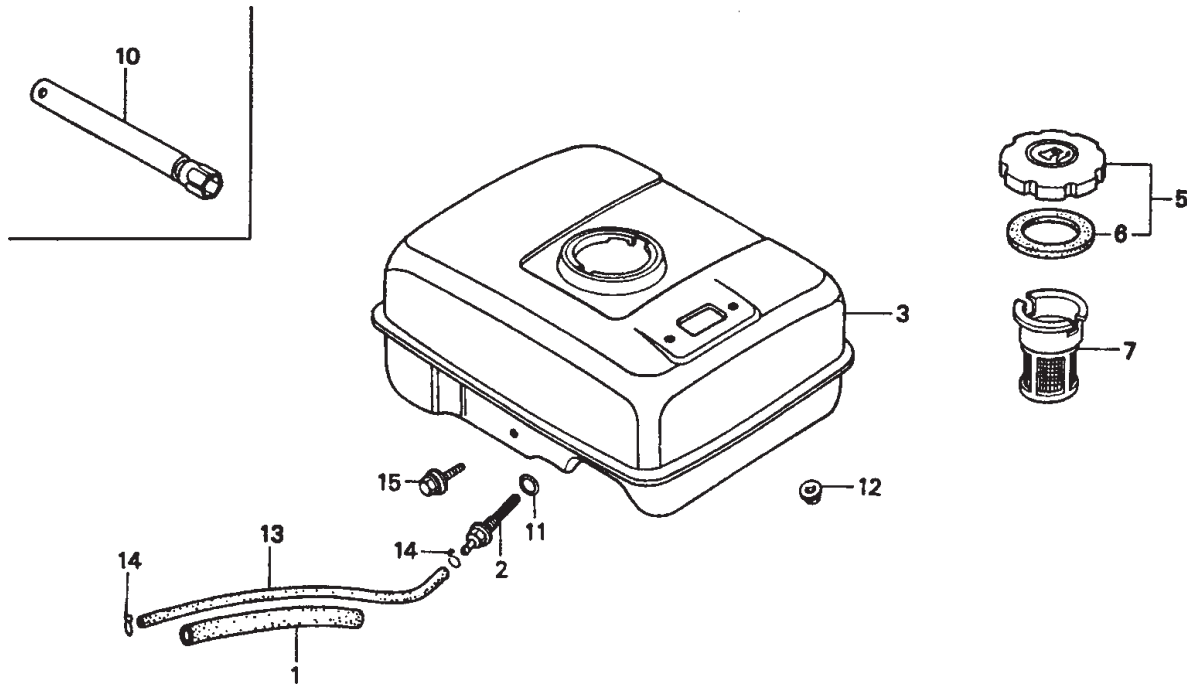

# HONDA GX160K1QA2 ENGINE — FUEL TANK ASSY.

## FUEL TANK ASSY.

<u>NO</u>	<u>PART NO</u>	<u>PART NAME</u>	<u>QTY.</u>	<u>REMARKS</u>
1	16854ZH8000	RUBBER, SUPPORTER	1	
2	16955ZE1000	JOINT, FUEL TANK	1	
3	17510ZE1020ZF	TANK COMP., FUEL NH1 (BLACK)	1	
5	17620ZH7013	CAP COMP., FUEL FILLER.....	1	INCLUDES ITEMS W/#
6#	17631ZH7003	GASKET, FUEL FILLER CAP	1	
7	17672ZE2W01	FILTER, FUEL	1	
10	89218ZE1000	WRENCH COMP., SPARK PLUG	1	
11	91353671003	O-RING (14MM) ARAI	1	
12	9405006000	NUT, FLANGE (6MM)	2	
13	950014500840M	BULK HOSE, FUEL (4.5X8000) (4.5X140)	1	
14	9500202080	CLIP, TUBE (B8)	2	
15	957010602500	BOLT, FLANGE (6X25)	1	

# HONDA GX160K1QA2 ENGINE — FLYWHEEL ASSY.

FLYWHEEL ASSY.

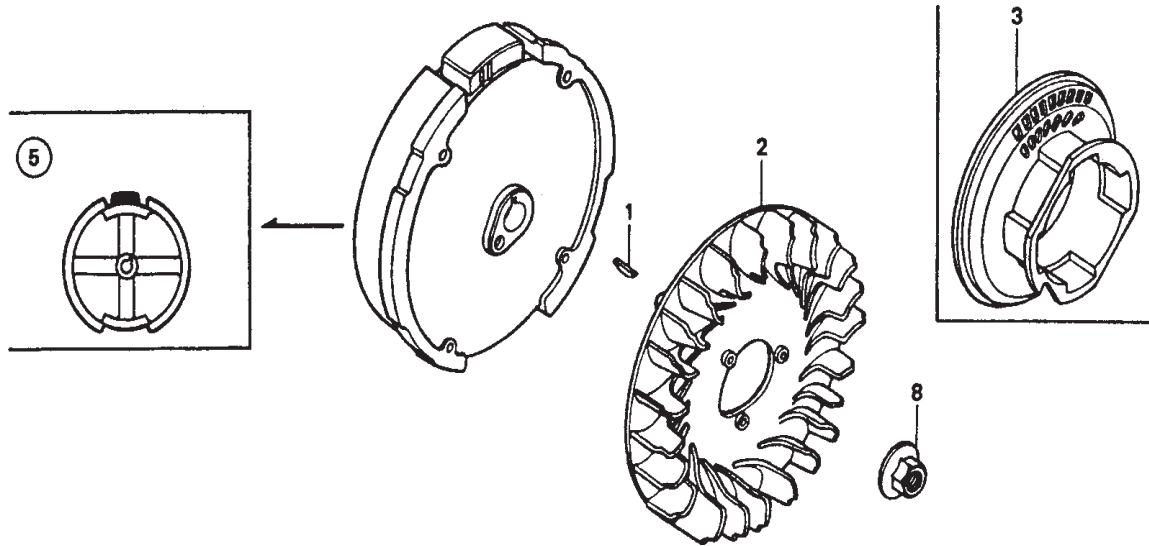

## HONDA GX160K1QA2 ENGINE — FLYWHEEL ASSY.

### FLYWHEEL ASSY.

<u>NO</u>	<u>PART NO</u>	<u>PART NAME</u>	<u>QTY.</u>	<u>REMARKS</u>
1	13331357000	KEY, SPECIAL WOOD RUFF, 25X18	1	
2	19511ZE1000	FAN, COOLING	1	
3	28450ZH8811	PULLEY COMP., STARTER	1	
5	31100ZE1000	FLYWHEEL COMP.	1	
	31100ZE1810	FLYWHEEL COMP., LAMP	1	
8	90201878003	NUT, SPECIAL, 14MM	1	

# HONDA GX160K1QA2 ENGINE — IGNITION COIL ASSY.

IGNITION COIL ASSY.

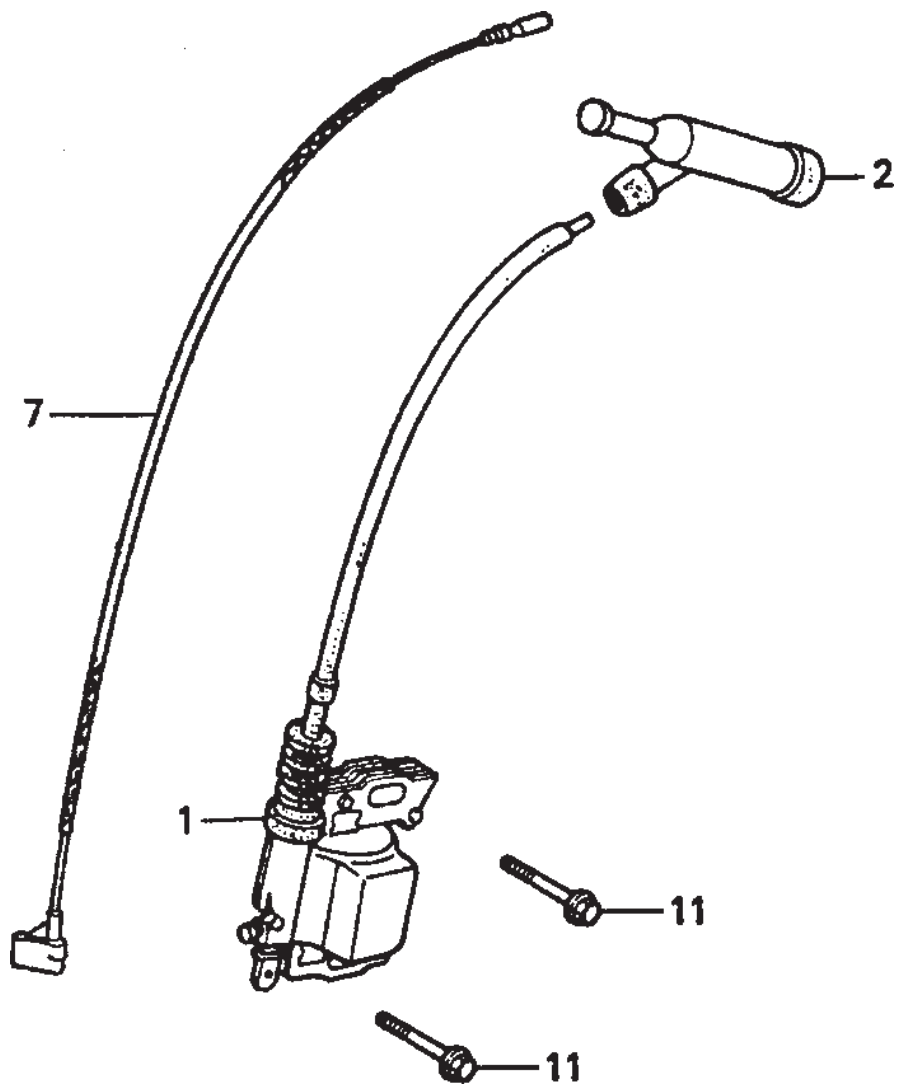

## HONDA GX160K1QA2 ENGINE — IGNITION COIL ASSY.

### IGNITION COIL ASSY.

<u>NO</u>	<u>PART NO</u>	<u>PART NAME</u>	<u>QTY.</u>	<u>REMARKS</u>
1	30500ZE1033	COIL ASSY., IGNITION	1	
2	30700ZE1013	CAP ASSY., NOISE SUPPRESSOR	1	
7	36101ZE1010	WIRE, STOP SWITCH (370MM)	1	
11	90121952000	BOLT, FLANGE, 6X25	2	

# HONDA GX160K1QA2 ENGINE — CONTROL ASSY.

CONTROL ASSY.

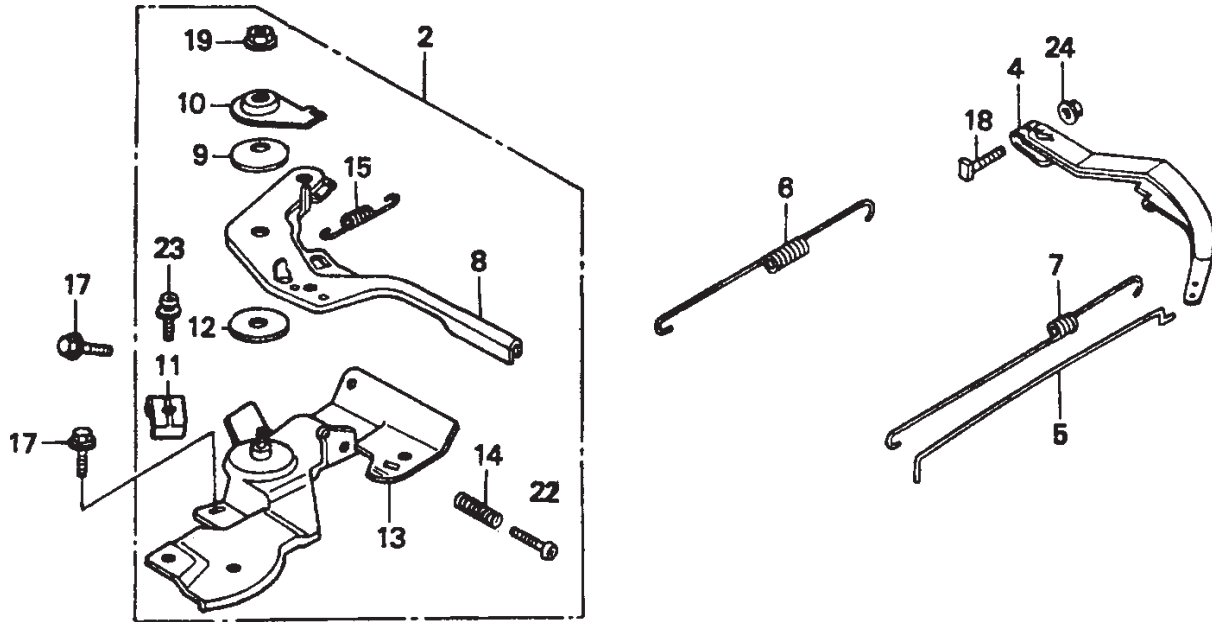

# HONDA GX160K1QA2 ENGINE — CONTROL ASSY.

## CONTROL ASSY.

<u>NO</u>	<u>PART NO</u>	<u>PART NAME</u>	<u>QTY.</u>	<u>REMARKS</u>
2	16500ZH8821	CONTROL ASSY., REMOTE .....	1	INCLUDES ITEMS W/*
4	16551ZE0010	ARM, GOVERNOR	1	
5	16555ZE1000	ROD, GOVERNOR	1	
6	16561ZE1020	SPRING, GOVERNOR	1	
7	16562ZE1020	SPRING, THROTTLE RETURN	1	
8*	16571ZH8000	LEVER, CONTROL	1	
9*	16574ZE1000	SPRING, LEVER	1	
10*	16575ZH8000	WASHER, CONTROL LEVER	1	
11*	16576891000	HOLDER, CABLE	1	
12*	16578ZE1000	SPACER, CONTROL LEVER	1	
13*	16580ZH8811	BASE COMP., CONTROL	1	
14*	16584883300	SPRING, CONTROL ADJUSTING	1	
15*	16592ZE1810	SPRING, CABLE RETURN	1	
17	90013883000	BOLT, FLANGE (6X12)	2	
18	90015ZE5010	BOLT, GOVERNOR ARM	1	
19*	90114SA0000	NUT,SELF- LOCK (6MM)	1	
22*	93500050250H	SCREW, PAN (5X25)	1	
23*	938930501600	SCREW WASHER (5X16)	1	
24	9405006000	NUT, FLANGE, 6MM	1	

# HONDA GX160K1QA2 ENGINE — LABEL ASSY.

LABEL ASSY.

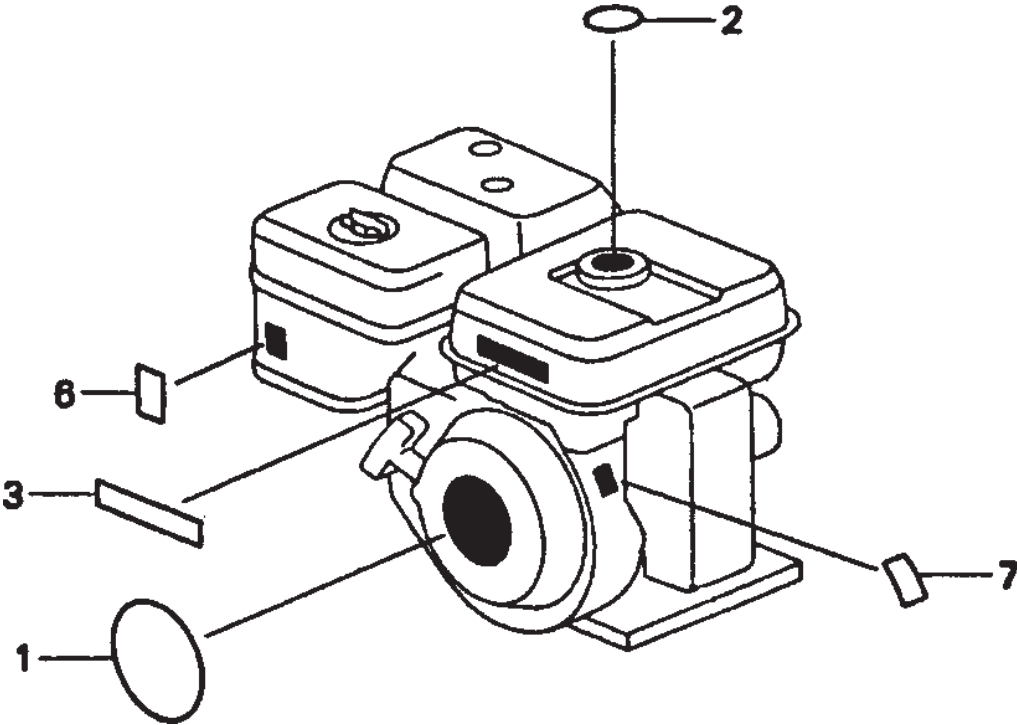

# HONDA GX160K1QA2 ENGINE — LABEL ASSY.

## LABEL ASSY.

<u>NO</u>	<u>PART NO</u>	<u>PART NAME</u>	<u>QTY.</u>	<u>REMARKS</u>
1	87521ZH8010	EMBLEM, INTERNAL	1	
2	87522ZE1810	MARK, CAUTION EXTERNAL	1	
3	87522ZH9000	LABEL, CAUTION	1	
6	87258ZE1810	MARK, CHOKE	1	
7	87530ZH8810	LABEL, SPECIFICATION EXTERNAL	1	



# HONDA GX160K1QA2 ENGINE — GASKET KIT ASSY.

## GASKET KIT ASSY.

<u>NO</u>	<u>PART NO</u>	<u>PART NAME</u>	<u>QTY.</u>	<u>REMARKS</u>
	06111ZH8405	GASKET KIT .....	1	INCLUDES ITEMS W/*
1*	11381ZH8801	GASKET, CASE COVER NON ASBEST	1	
2*	12251ZF1800	GASKET, CYLINDER HEAD	1	
3*	12391ZE1000	GASKET, CYLINDER HEAD COVER	1	
4*	16212ZH8800	GASKET, INSULATOR	1	
5*	16221ZH8801	GASKET, CARBURATOR	1	
6*	18381ZH8800	GASKET, MUFFLER	1	

# ROBIN EH-17 ENGINE — CRANKCASE ASSY.

## CRANKCASE GROUP ASSY.

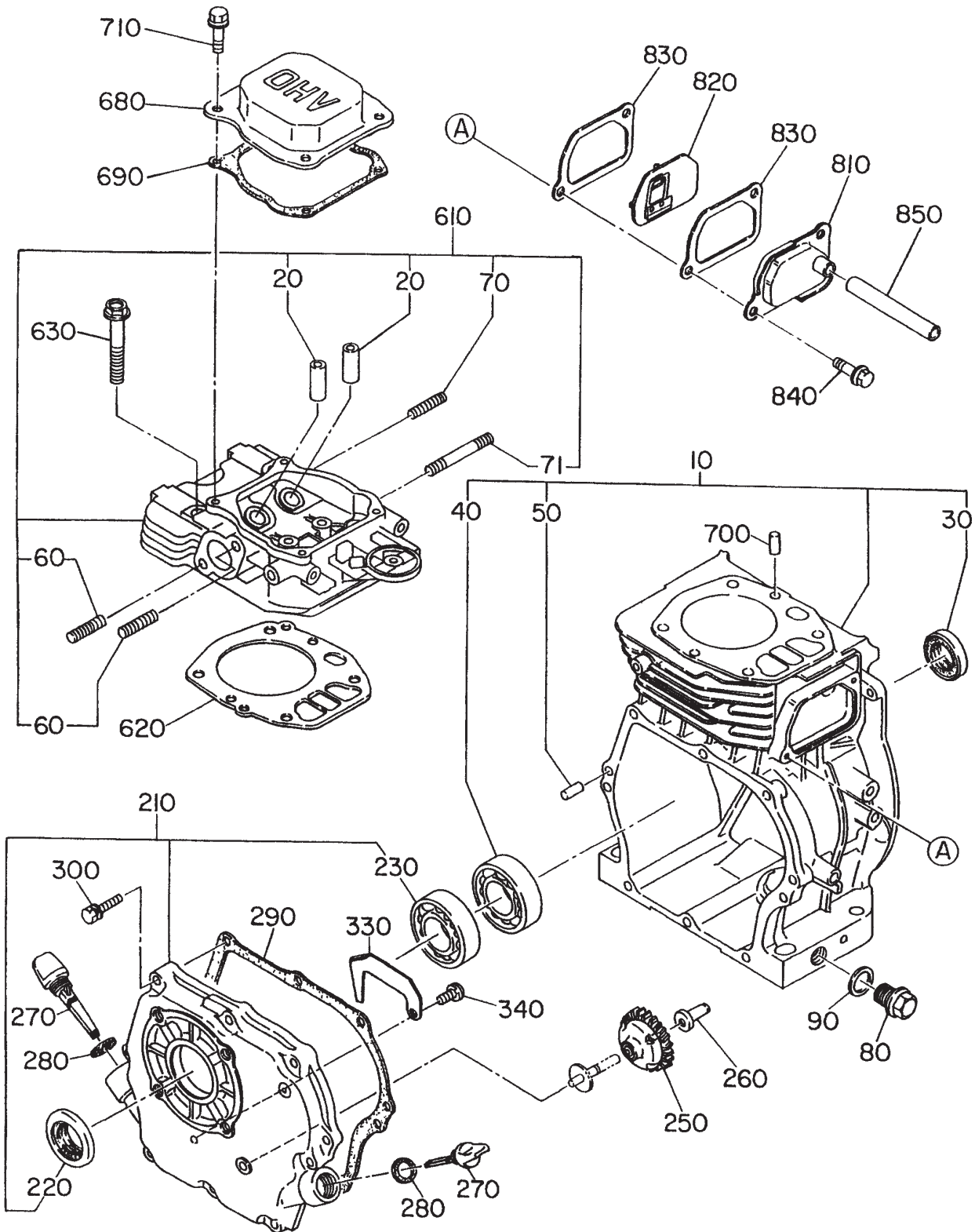

# ROBIN EH-17 ENGINE — CRANKCASE ASSY.

## CRANKCASE GROUP ASSY.

<u>NO.</u>	<u>PART NO.</u>	<u>PART NAME</u>	<u>QTY.</u>	<u>REMARKS</u>
10	2691010101	CRANKCASE CP (RECOIL START TYPE) .....	1 .....	INCLUDES ITEMS W/*
20%	2371420203	VALVE GUIDE OVERSIZE	2	
30*	0440250070	OIL SEAL	1	
40*	0600250010	BALL BEARING 6205C3	1	
50*	0310060020	DOWEL PIN	2	
60%	0105080290	STUD	2	
70%	0105060131	STUD	1	
71%	0013906600	STUD	1	
80	0401140030	PLUG	2	
90	0211140020	GASKET	2	
210	2531101401	MAIN BEARING COVER CP .....	1 .....	INCLUDES ITEMS W/+
220+	0440250160	OIL SEAL	1	
230+	0600250010	BALL BEARING, 6205C3	1	
250	2274500301	GOVERNOR GEAR CP	1	
260	2054190103	GOVERNOR SLEEVE	1	
270	2696360103	OIL GAUGE	2	
	2696360103	OIL GAUGE .....	1 .....	W/OIL SENSOR
280	0213160020	GASKET	2	
	0213160020	GASKET .....	1 .....	W/OIL SENSOR
290	2531600203	GASKET, BEARING COVER	1	
300	0130060040	BOLT AND WASHER AY	8	
330	2531750203	SHELTER PLATE .....	1 .....	W/OIL SENSOR
340	0043505100	SCREW AND WASHER AY .....	1 .....	W/OIL SENSOR
610	2691300101	CYLINDER HEAD CP .....	1 .....	INCLUDES ITEMS W/%
620	2531500123	GASKET, HEAD	1	
630	0110080100	FLANGE BOLT	4	
680	2691550303	ROCKER COVER	1	
690	2691600403	GASKET, ROCKER COVER	1	
700	0310060020	DOWEL PIN	2	
710	0110060020	FLANGE BOLT	4	
810	2531430111	BREATHER COVER CP	1	
820	2531440111	BREATHER PLATE CP	1	
830	2531600633	GASKET, BREATHER COVER	2	
840	0110060030	FLANGE BOLT	2	
850	0851080000	RUBBER PIPE	1	
960	2539900107	GASKET SET	1	

# ROBIN EH-17 ENGINE — CRANKSHAFT ASSY.

CRANKSHAFT ASSY.

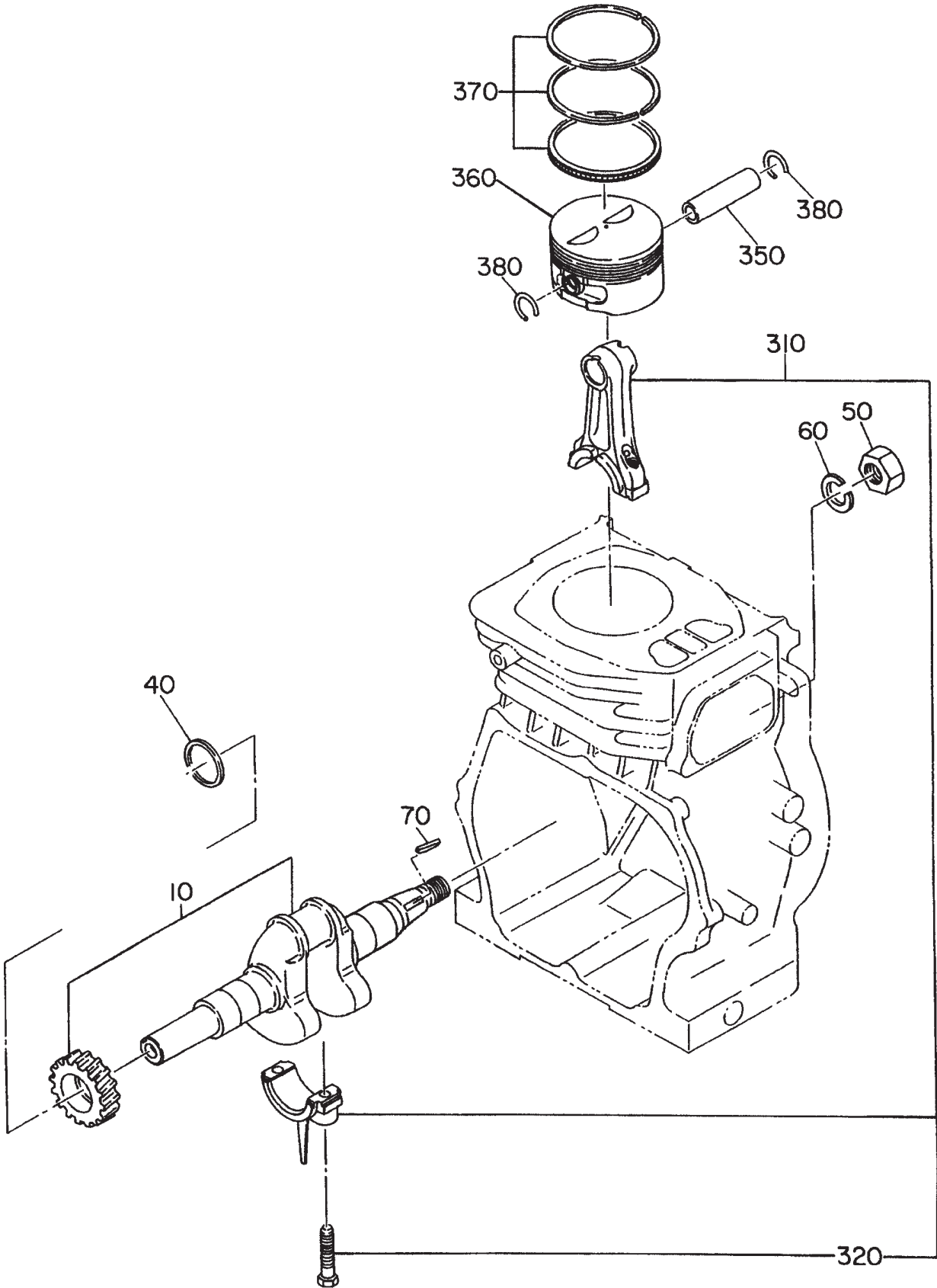

# ROBIN EH-17 ENGINE — CRANKSHAFT ASSY.

## CRANKSHAFT ASSY.

<u>NO.</u>	<u>PART NO.</u>	<u>PART NAME</u>	<u>QTY.</u>	<u>REMARKS</u>
10	2532090101	CRANKSHAFT CP .....	1 .....	SAE 3/4"KEYED SHAFT TYPE
40	0230250110	SPACER T=0.6 .....	1 .....	SELECT ONE SPACER ONLY
	0230250120	SPACER T=0.8 .....	1 .....	SELECT ONE SPACER ONLY
	0230250130	SPACER T=1.0 .....	1 .....	SELECT ONE SPACER ONLY
50	0221814000	NUT	1	
60	0032014000	SPRING WASHER	1	
70	0323030010	WOODRUFF KEY	1	
310	2532250120	CONNECTING ROD ASSY.....	1 .....	INCLUDES ITEMS W/*
320*	2512300103	CONNECTING ROD BOLT	2	
350	2692330103	PISTON PIN .....	1 .....	ELECTRIC START TYPE
360	2692340103	PISTON .....	1 .....	STANDARD
	2692340203	PISTON .....	1 .....	OVERSIZE 0.25 MM
	2692340303	PISTON .....	1 .....	OVERSIZE 0.50 MM
370	2532350117	PISTON RING SET .....	1 .....	STANDARD
	2532350217	PISTON RING SET .....	1 .....	OVERSIZE 0.25 MM
	2532350317	PISTON RING SET .....	1 .....	OVERSIZE 0.50 MM
380	0565160010	CLIP	2	

# ROBIN EH-17 ENGINE — INTAKE AND EXHAUST ASSY.

## INTAKE AND EXHAUST ASSY.

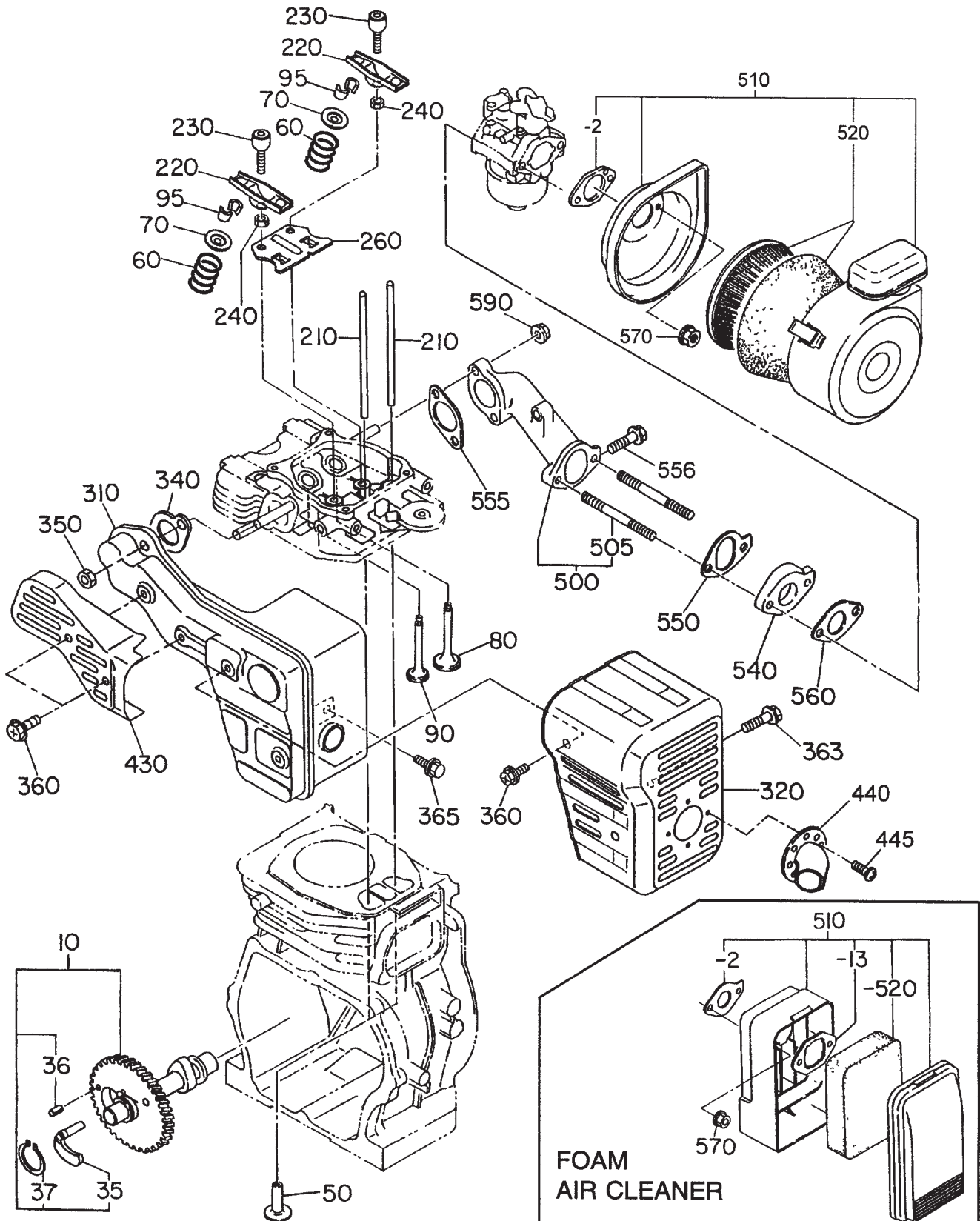

# ROBIN EH-17 ENGINE — INTAKE AND EXHAUST ASSY.

## INTAKE AND EXHAUST ASSY.

<u>NO.</u>	<u>PART NO.</u>	<u>PART NAME</u>	<u>QTY.</u>	<u>REMARKS</u>
10	2533170111	CAMSHAFT CP .....	1 .....	INCLUDES ITEMS W/*
35*	2273646113	RELEASE LEVER	1	
36*	0051904100	SPRING PIN	1	
37*	0031522000	SNAP RING	1	
50	2393330113	TAPPET	2	
60	2533360103	VALVE SPRING	2	
70	13209KA040	SPRING RETAINER	2	
80	2693340103	INTAKE VALVE	1	
90	2693350103	EXHAUST VALVE	1	
95	13210KA031	COLLET VALVE	4	
210	2693530103	PUSH ROD	2	
220	26136001A3	ROCKER ARM	2	
230	2693580103	BOLT, PIVOT	2	
240	0170060090	NUT	2	
260	2693650103	GUIDE PLATE	1	
310	2693010101	MUFFLER CP	1	
320	2533420111	MUFFLER COVER	1	
340	2533520103	GASKET, MUFFLER	1	
350	0170080030	NUT	2	
360	0152060090	TAPPING BOLT	4	
363	0152060100	TAPPING BOLT	1	
365	0110060020	FLANGE BOLT	1	
430	2693480103	EXHAUST PIPE COVER	1	
440	2363700101	DEFLECTOR, EXHAUST	1	
445	0150040010	TAPPING SCREW	2	
505	0105060230	STUD	2	
510	2533261310	AIR CLEANER ASSY. ....	1 .....	CYCLONE, TOP INLET TYPE
-2	2363263008	PACKING .....	1 .....	CYCLONE, TOP INLET TYPE
510	2693260100	AIR CLEANER ASSY. ....	1 .....	FOAM AIR CLEANER TYPE
-2	2273600413	PACKING .....	1 .....	FOAM AIR CLEANER TYPE
-13	2693265108	PLATE .....	1 .....	FOAM AIR CLEANER TYPE
-520	2693261008	AIR CLEANER ELEMENT .....	1 .....	FOAM AIR CLEANER TYPE
520	2273261007	ELEMENT SET .....	1 .....	CYCLONE, TOP INLET TYPE
540	2533290103	INSULATOR	1	
550	2533590103	GASKET 3, INSULATOR	1	
555	2273590103	GASKET INSULATOR	1	
556	0110060130	FLANGE BOLT	1	
560	2363590303	GASKET 2, INSULATOR	1	
570	2263921200	NUT AND WASHER ASSY. ....	2 .....	CYCLONE, TOP INLET TYPE
570	0023806000	FLANGE NUT .....	2 .....	FOAM AIR CLEANER TYPE
590	0023806000	FLANGE NUT	2	

# ROBIN EH-17 ENGINE — GOVERNOR ASSY.

GOVERNOR ASSY.

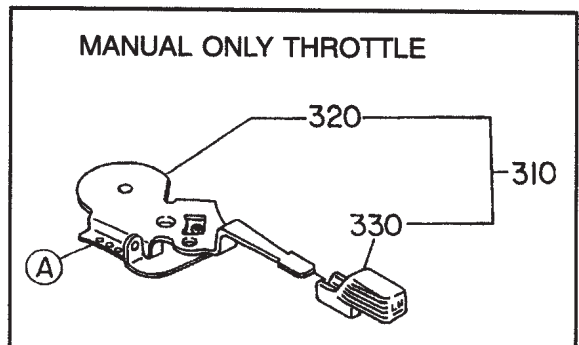
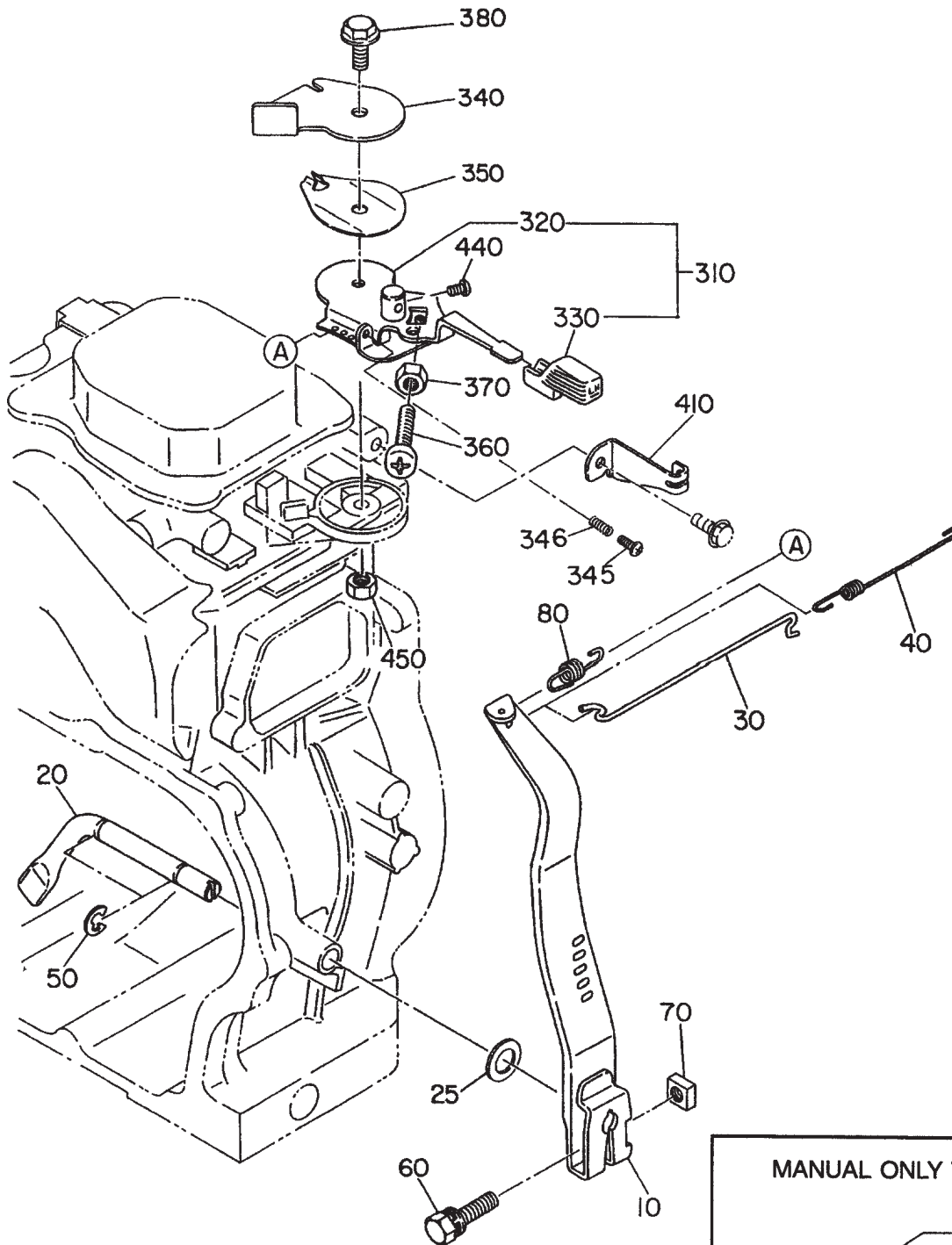

# ROBIN EH-17 ENGINE — GOVERNOR ASSY.

## GOVERNOR ASSY.

<u>NO.</u>	<u>PART NO.</u>	<u>PART NAME</u>	<u>QTY.</u>	<u>REMARKS</u>
10	2534230123	GOVERNOR LEVER	1	
20	2274220103	GOVERNOR SHAFT	1	
25	0031108000	WASHER	1	
30	2534270101	GOVERNOR ROD CP.	1	
40	2534280103	ROD SPRING	1	
50	0031306000	CLIP	2	
60	0011406300	BOLT AND WASHER ASSY.	1	
70	0186060020	NUT	1	
80	2534250123	GOVERNOR SPRING	1	
310	2694330200	SPEED CONTROL ASSY. ....	1	MANUAL W/REMOTE CABLE OPT.
310	2694330100	SPEED CTRL. ASSY. MAN. CTRL. ....	1	INCLUDES ITEMS W/*
320*	2694330201	SPEED CONTROL CP .....	1	MANUAL W/REMOTE CABLE OPT.
320	2694330101	SPEED CONTROL CP .....	1	MANUAL CONTROL ONLY
330*	2274360103	KNOB	1	
340	2694350103	STOP PLATE	1	
345	0043104300	SCREW, PANHEAD	1	
346	2694550303	IDLE SET SPRING	1	
350	2274500203	SPRING WASHER	1	
360	0043106300	SCREW	1	
370	0022706000	NUT	1	
380	0110060050	FLANGE BOLT .....	1	MANUAL W/REMOTE CABLE OPT.
380	0110060030	FLANGE BOLT .....	1	MANUAL CONTROL ONLY
410	2534420013	WIRE BRACKET .....	1	MANUAL W/REMOTE CABLE OPT.
440	0043104080	SCREW .....	1	MANUAL W/REMOTE CABLE OPT.
450	0022706000	NUT .....	1	MANUAL W/REMOTE CABLE OPT.

# ROBIN EH-17 ENGINE — COOLING AND STARTING ASSY.

COOLING AND STARTING ASSY.

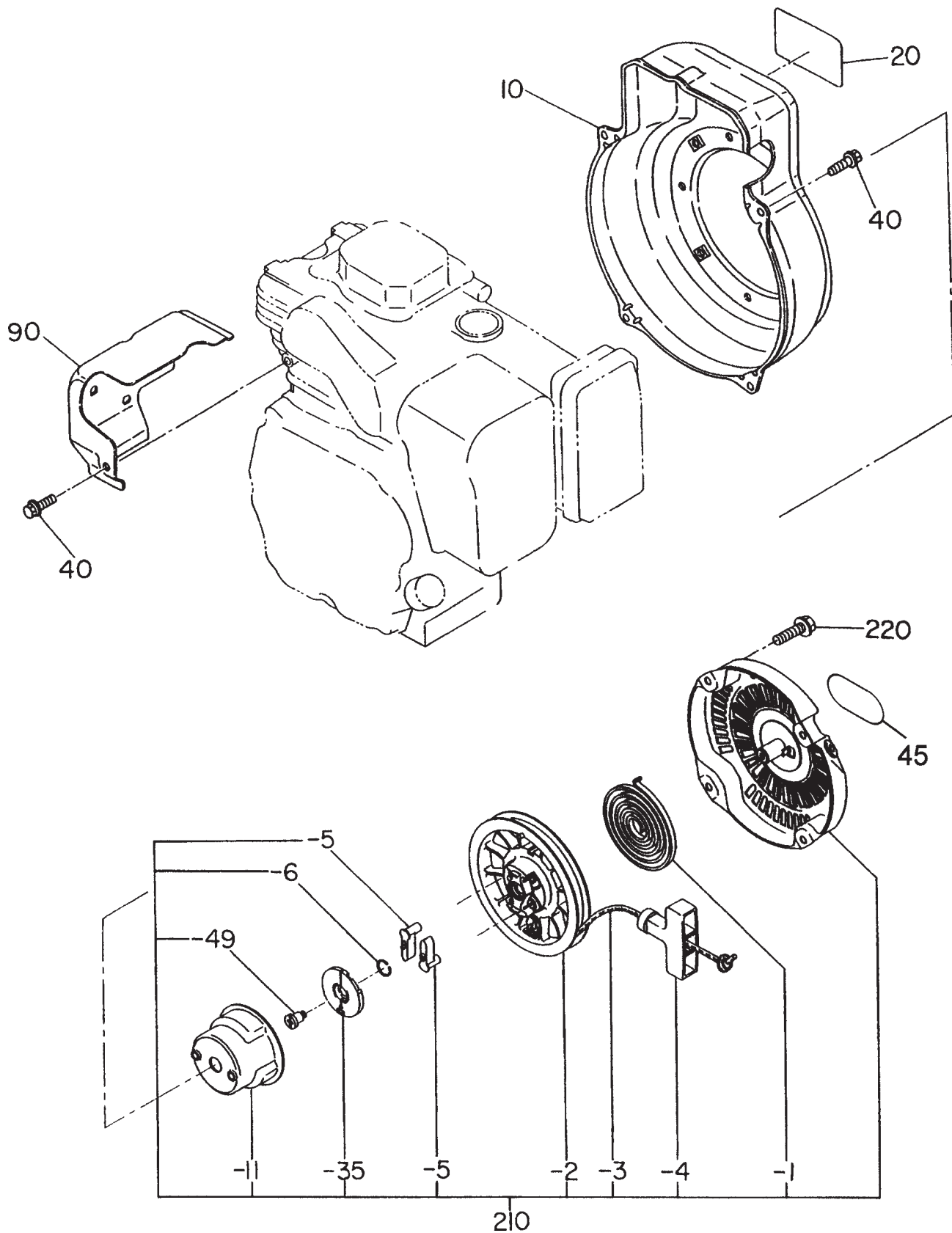

# ROBIN EH-17 ENGINE — COOLING AND STARTING ASSY.

## COOLING AND STARTING ASSY.

<u>NO.</u>	<u>PART NO.</u>	<u>PART NAME</u>	<u>QTY.</u>	<u>REMARKS</u>
10	2535161201	BLOWER HOUSING CP. ....	1 .....	BLACK
20	2699170303	LABEL, TRADE MARK	1	
40	0110060020	FLANGE BOLT	5	
45	0732004950	LABEL, RECOIL OHV	1	
90	2535270103	HEAD COVER	1	
210	2695020100	RECOIL STARTER ASSY. ....	1 .....	INCLUDES ITEMS W/*
-1*	2705011508	SPIRAL SPRING	1	
-2*	2695012008	REEL	1	
-3*	2695011008	STARTER ROPE	1	
-4*	2615010008	STARTER KNOB	1	
-5*	2705012508	RATCHET	2	
-6*	2275013108	FRICTION SPRING	1	
-11*	2695014508	STARTER PULLEY	1	
-35*	2705026108	RATCHET GUIDE	1	
-49*	2275015208	SET SCREW	1	
220	0110060010	FLANGE BOLT	4	

# ROBIN EH-17 ENGINE — FUEL TANK ASSY.

FUEL TANK ASSY.

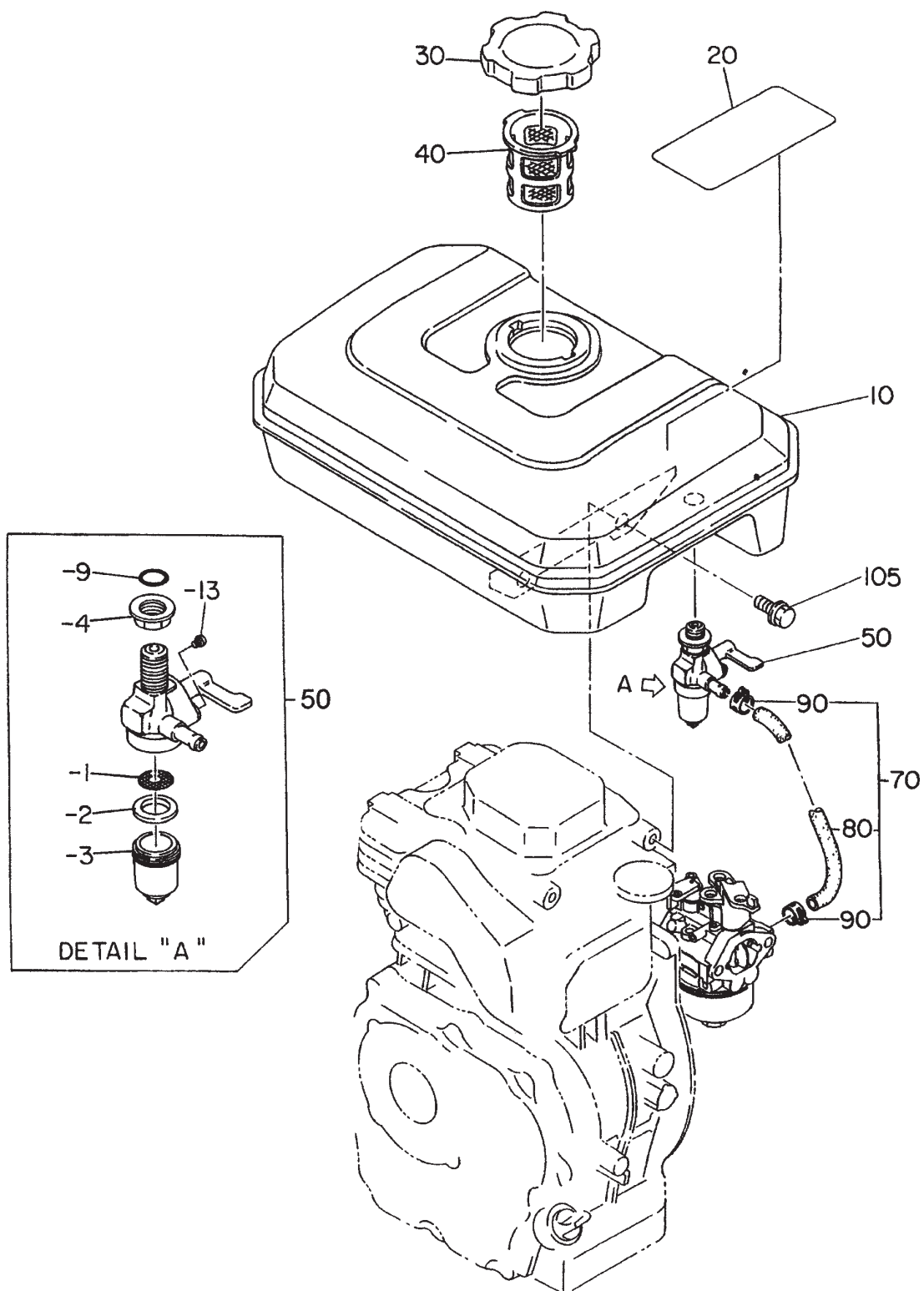

# ROBIN EH-17 ENGINE — FUEL TANK ASSY.

## FUEL TANK ASSY.

<u>NO.</u>	<u>PART NO.</u>	<u>PART NAME</u>	<u>QTY.</u>	<u>REMARKS</u>
10	2536010801	FUEL TANK CP. BLACK	1	
20	0732003900	LABEL, CAUTION	1	
30	0430430015	FUEL TANK CAP CP	1	
40	0641360010	FUEL, FILTER	1	
50	0642008400	FUEL, STRAINER ASSY. ....	1	INCLUDES ITEMS W/*
-1*	0642004220	FILTER	1	
-2*	0642006410	PACKING	1	
-3*	0642007810	CUP	1	
-4*	0642008410	NUT	1	
-9*	0642008420	O-RING	1	
-13*	0642004790	SCREW, PANHEAD	2	
70	2696260101	FUEL PIPE CP .....	1	INCLUDES ITEMS W/%
80%	2696800103	RUBBER PIPE	1	
90%	0561110020	HOSE CLAMP	2	
105	0110060030	FLANGE BOLT	4	

# ROBIN EH-17 ENGINE — CARBURETOR ASSY.

CARBURETOR ASSY.

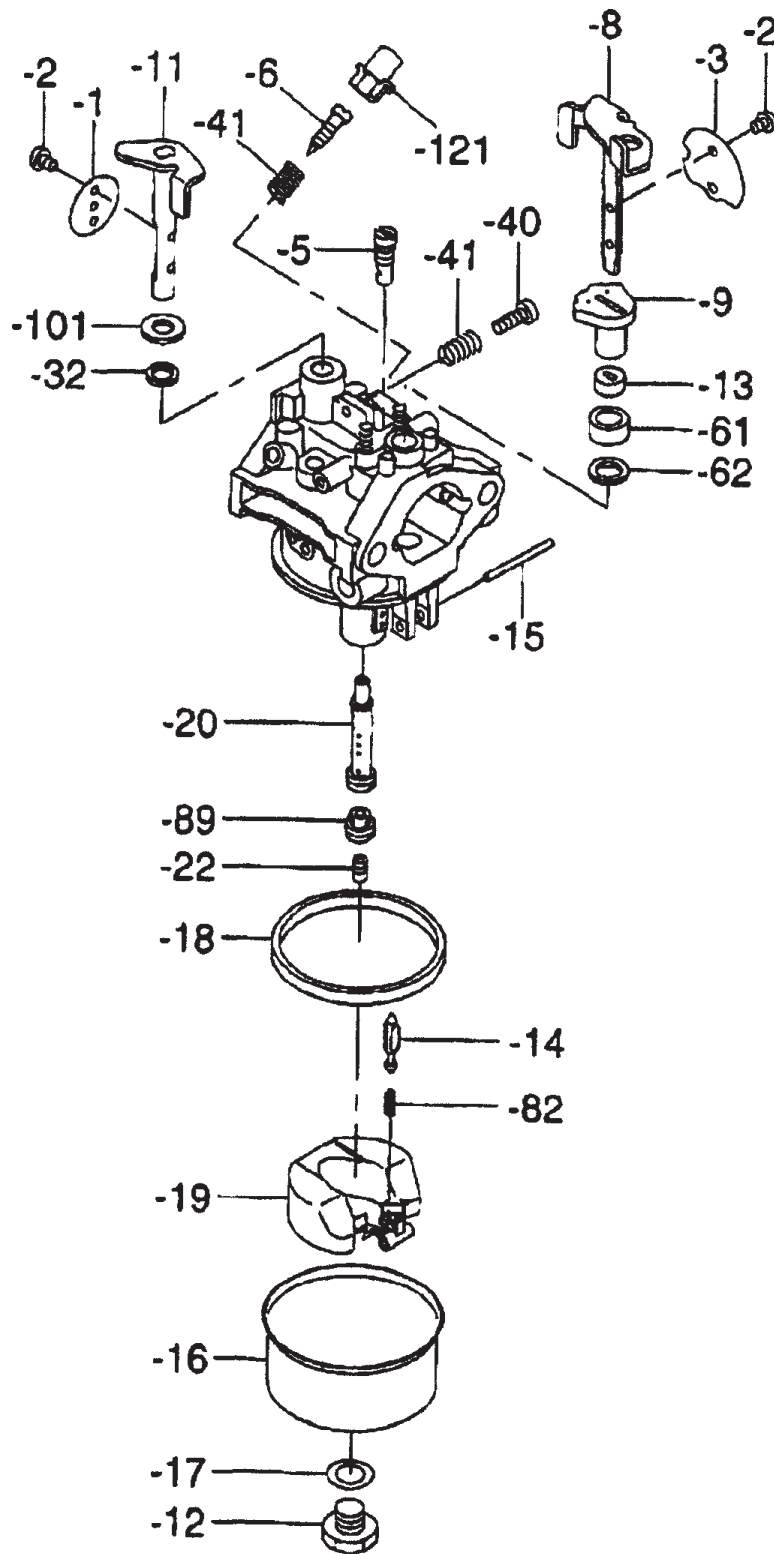

# ROBIN EH-17 ENGINE — CARBURETOR ASSY.

## CARBURETOR ASSY.

<u>NO.</u>	<u>PART NO.</u>	<u>PART NAME</u>	<u>QTY.</u>	<u>REMARKS</u>
210	2536245610	CARB. ASSY. CYCLONE, TOP INLET .....	1 .....	INCLUDES ITEMS W/*
210	2536245010	CARBURETOR ASSY. ....	1 .....	FOAM AIR CLEANER TYPE
-1*	2206253608	THROTTLE VALVE	1	
-2*	2376245108	SCREW	4	
-3*	2366252808	CHOKE VALVE	1	
-5*	2536242008	PILOT JET	1	
-6*	2466243608	ADJUSTER	1	
-8*	2366252008	CHOKE LEVER	1	
-9*	2396256008	RING .....	1 .....	CYCLONE, TOP INLET TYPE
	2346255008	RING .....	1 .....	FOAM AIR CLEANER TYPE
-11*	2366260008	THROTTLE SHAFT .....	1 .....	CYCLONE, TOP INLET TYPE
	2366253008	THROTTLE SHAFT .....	1 .....	FOAM AIR CLEANER TYPE
-12*	2366245108	BOLT	1	
-13*	2266255008	RING	1	
-14*	1616235208	NEEDLE	1	
-15*	2366251008	PIN	1	
-16*	2366255108	FLOAT CHAMBER BODY ASSY.	1	
-17*	2366245008	PACKING	1	
-18*	2366254008	PACKING,CHAMBER	1	
-19*	2366250508	FLOAT	1	
-20*	2386244008	MAIN NOZZLE	1	
-22*	2536240208	MAIN JET	1	
-32*	1066239208	SEAL .....	1 .....	CYCLONE, TOP INLET TYPE
-40*	2466243508	ADJUST SCREW	1	
-41*	2096244508	SPRING	2	
-61*	2476255008	CAP, CHOKE .....	1 .....	CYCLONE, TOP INLET TYPE
-62*	2366268008	SEAL .....	1 .....	CYCLONE, TOP INLET TYPE
-82*	2366244508	SPRING	1	
-89*	2356242508	GUIDE HOLDER	1	
-101*	2366263108	RING .....	1 .....	CYCLONE, TOP INLET TYPE
-121*	2466255108	CAP	1	

# ROBIN EH-17 ENGINE — FLYWHEEL AND IGNITION ASSY.

FLYWHEEL AND IGNITION ASSY.

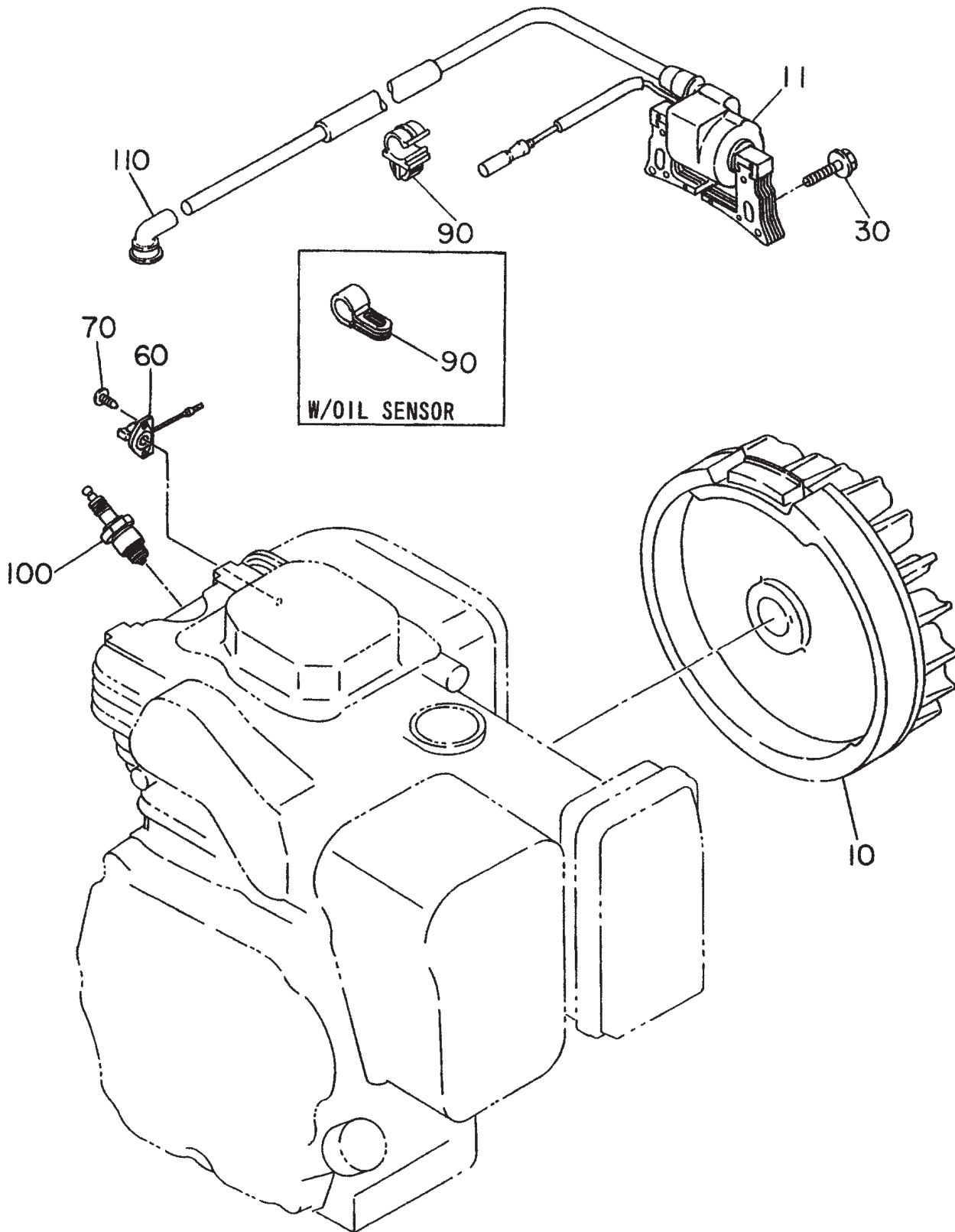

# ROBIN EH-17 ENGINE — FLYWHEEL AND IGNITION ASSY.

## FLYWHEEL AND IGNITION ASSY.

<u>NO.</u>	<u>PART NO.</u>	<u>PART NAME</u>	<u>QTY.</u>	<u>REMARKS</u>
10	2697933001	FLYWHEEL CP	1	
11	2697943001	IGNITION COIL CP	1	
30	0011406250	BOLT AND WASHER ASSY.	2	
60	0660000361	SWITCH ASSY.	1	
70	0150040090	TAPPING SCREW	2	
90	0566000190	CLAMP	1	
	0566120050	CLAMP .....	1	W/OIL SENSOR
100	0650140031	SPARK PLUG .....	1	NGK B6HS
	0650140150	SPARK PLUG .....	1	NGK BR6HS
	0650141030	SPARK PLUG .....	1	CHAMPION L86C
110	0655000051	SPARK PLUG CAP		

**ROBIN EH-17 ENGINE — OIL SENSOR ASSY.**

OIL SENSOR ASSY.

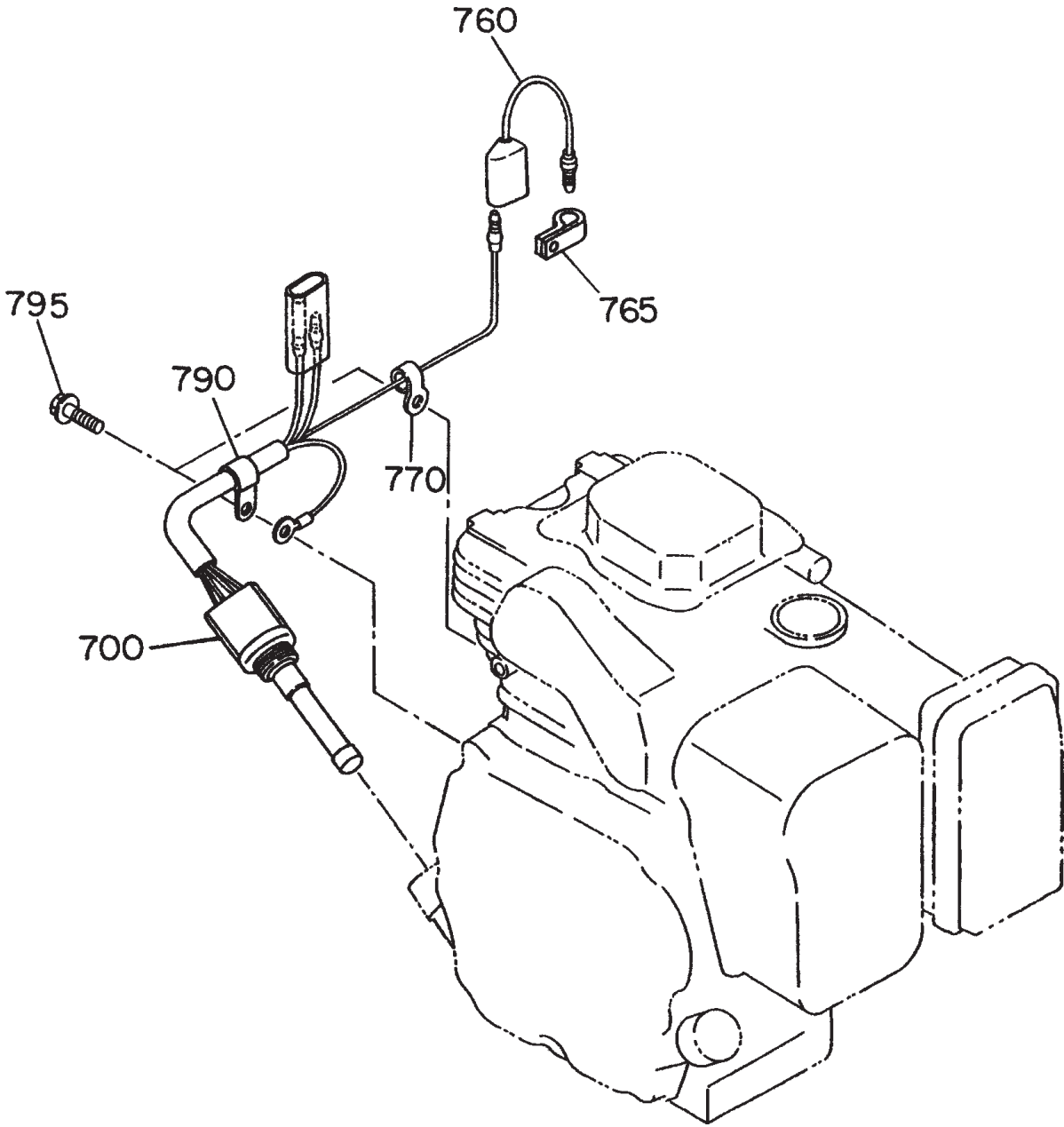

# ROBIN EH-17 ENGINE — OIL SENSOR ASSY.

## OIL SENSOR ASSY.

<u>NO.</u>	<u>PART NO.</u>	<u>PART NAME</u>	<u>QTY.</u>	<u>REMARKS</u>
700	KS31102211	OIL SENSOR CP 13 .....	1 .....	W/OIL SENSOR
760	2147312201	WIRE 22 CP .....	1 .....	W/OILSENSOR
765	2067550101	CLAMP CP .....	1 .....	W/OIL SENSOR
770	2077500101	CLAMP CP .....	1 .....	W/OIL SENSOR 056-60002-60
790	2147900301	CLAMP CP .....	1 .....	W/OIL SENSOR
795	0011008160	BOLT AND WASHER ASSY.....	3 .....	W/OIL SENSOR

**PAYMENT TERMS**

Terms of payment for parts are net 10 days.

**FREIGHT POLICY**

All parts orders will be shipped collect or prepaid with the charges added to the invoice. All shipments are F.O.B. point of origin. Multiquip's responsibility ceases when a signed manifest has been obtained from the carrier, and any claim for shortage or damage must be settled between the consignee and the carrier.

**MINIMUM ORDER**

The minimum charge for orders from Multiquip is \$15.00 net. Customers will be asked for instructions regarding handling of orders not meeting this requirement.

**RETURNED GOODS POLICY**

Return shipments will be accepted and credit will be allowed, subject to the following provisions:

1. A Returned Material Authorization must be approved by Multiquip prior to shipment.
2. To obtain a Return Material Authorization, a list must be provided to Multiquip Parts Sales that defines item numbers, quantities, and descriptions of the items to be returned.
  - a. The parts numbers and descriptions must match the current parts price list.
  - b. The list must be typed or computer generated.
  - c. The list must state the reason(s) for the return.
  - d. The list must reference the sales order(s) or invoice(s) under which the items were originally purchased.
  - e. The list must include the name and phone number of the person requesting the RMA.
3. A copy of the Return Material Authorization must accompany the return shipment.

4. Freight is at the sender's expense. All parts must be returned freight prepaid to Multiquip's designated receiving point.
5. Parts must be in new and resalable condition, in the original Multiquip package (if any), and with Multiquip part numbers clearly marked.
6. The following items are not returnable:
  - a. Obsolete parts. (If an item is listed in the parts price book as being replaced by another item, it is obsolete.)
  - b. Any parts with a limited shelf life (such as gaskets, seals, "O" rings, and other rubber parts) that were purchased more than six months prior to the return date.
  - c. Any line item with an extended dealer net price of less than \$5.00.
  - d. Special order items.
  - e. Electrical components.
  - f. Paint, chemicals, and lubricants.
  - g. Decals and paper products.
  - h. Items purchased in kits.
7. The sender will be notified of any material received that is not acceptable.
8. Such material will be held for 5 working days from notification, pending instructions. If a reply is not received within 5 days, the material will be returned to the sender at his expense.
9. Credit on returned parts will be issued at dealer net price at time of the original purchase, less a 15% restocking charge.
10. In cases where an item is accepted for which the original purchase document can not be determined, the price will be based on the list price that was effective twelve months prior to the RMA date.
11. Credit issued will be applied to future purchases only.

**PRICING AND REJATES**

Prices are subject to change without prior notice. Price changes are effective on a specific date and all orders received on or after that date will be billed at the revised price. ReJAtes for price declines and added charges for price increases will not be made for stock on hand at the time of any price change.

Multiquip reserves the right to quote and sell direct to Government agencies, and to Original Equipment Manufacturer accounts who use our products as integral parts of their own products.

**SPECIAL EXPEDITING SERVICE**

A \$20.00 to \$50.00 surcharge will be added to the invoice for special handling including bus shipments, insured parcel post or in cases where Multiquip must personally deliver the parts to the carrier.

**LIMITATIONS OF SELLER'S LIABILITY**

Multiquip shall not be liable here under for damages in excess of the purchase price of the item with respect to which damages are claimed, and in no event shall Multiquip be liable for loss of profit or good will or for any other special, consequential or incidental damages.

**LIMITATION OF WARRANTIES**

No warranties, express or implied, are made in connection with the sale of parts or trade accessories nor as to any engine not manufactured by Multiquip. Such warranties made in connection with the sale of new, complete units are made exclusively by a statement of warranty packaged with such units, and Multiquip neither assumes nor authorizes any person to assume for it any other obligation or liability whatever in connection with the sale of its products. A part from such written statement of warranty, there are no warranties, express, implied or statutory, which extend beyond the description of the products on the face hereof.



# PARTS AND OPERATION MANUAL

## **HERE'S HOW TO GET HELP**

*PLEASE HAVE THE MODEL AND SERIAL NUMBER  
ON-HAND WHEN CALLING*

### **PARTS DEPARTMENT**

*800-427-1244 or 310-537-3700*

*FAX: 800-672-7877 or 310-637-3284*

### **SERVICE DEPARTMENT/TECHNICAL ASSISTANCE**

*800-478-1244 or 310-537-3700*

*FAX: 310- 537-4259*

### **WARRANTY DEPARTMENT**

*888-661-4279, or 310-661-4279*

*FAX: 310- 537-1173*

### **MAIN**

*800-421-1244 or 310-537-3700*

*FAX: 310-537-3927*



#### **MULTIQUIP INC.**

POST OFFICE BOX 6254

CARSON, CA 90749

310-537-3700 • 800-421-1244

FAX: 310-537-3927

E-MAIL: [mq@multiquip.com](mailto:mq@multiquip.com)

WWW: [multiquip.com](http://multiquip.com)

Atlanta • Boise • Dallas • Houston • Newark  
Quebec, Canada • Manchester, UK • Rio De Janeiro, BR • Guadalajara, MX