

OPERATION AND PARTS MANUAL



MAYCO SERIES MODELS LS-60TD STRUCTURAL CONCRETE PUMPS (DEUTZ DIESEL ENGINES)

Revision #2 (08/16/05)

**THIS MANUAL MUST ACCOMPANY
THE EQUIPMENT AT ALL TIMES.**



WARNING



CALIFORNIA — Proposition 65 Warning

Diesel engine exhaust and some of its constituents are known to the State of California to cause cancer, birth defects and other reproductive harm.

HERE'S HOW TO GET HELP

PLEASE HAVE THE MODEL AND SERIAL
NUMBER *ON-HAND* WHEN CALLING

MULTIQUIP CORPORATE OFFICE

18910 Wilmington Ave.

Carson, CA 90746

Email: mq@multiquip.com

Internet: www.multiquip.com

800-421-1244

FAX: 310-537-3927

PARTS DEPARTMENT

800-427-1244

310-537-3700

FAX: 800-672-7877

FAX: 310-637-3284

MAYCO PARTS

800-306-2926

310-537-3700

FAX: 800-672-7877

FAX: 310-637-3284

SERVICE DEPARTMENT

800-421-1244

310-537-3700

FAX: 310-537-4259

TECHNICAL ASSISTANCE

800-478-1244

FAX: 310-631-5032

WARRANTY DEPARTMENT

800-421-1244, EXT. 279

310-537-3700, EXT. 279

FAX: 310-537-1173

© COPYRIGHT 2004-2005, MULTIQUIP INC.

Multiquip Inc, the MQ logo and the Mayco logo are registered trademarks of Multiquip Inc. and may not be used, reproduced, or altered without written permission. All other trademarks are the property of their respective owners and used with permission.

This manual **MUST** accompany the equipment at all times. This manual is considered a permanent part of the equipment and should remain with the unit if resold.

The information and specifications included in this publication were in effect at the time of approval for printing. Illustrations are based on the *Mayco LS-60TD Concrete Pumps*. Illustrations, descriptions, references and technical data contained in this manual are for guidance only and may not be considered as binding. Multiquip Inc. reserves the right to discontinue or change specifications, design or the information published in this publication at any time without notice and without incurring any obligations.

**To find the latest revision of this
publication, visit our website at:
www.multiquip.com**



TABLE OF CONTENTS

MAYCO LS-60TD STRUCTURAL CONCRETE PUMP

- Proposition 65 Warning 2
- Here's how To Get Help 3
- Table of Contents 4
- Parts Ordering Procedures 5
- Specifications 6
- Dimensions 7
- Safety Message Alert Symbols 8-9
- Rules for Safe Operation 10-12
- Operation and Safety Decals 14-15
- Important Hand Signals 16
- General Information 17-18
- How it Works 19
- Pump Components 20-21
- Control Box Components 22
- Engine Components 23
- Inspection 24-26
- Start-Up Procedure 27-29
- Shut-Down Procedure 29
- Operating Procedures 30-36
- Trailer Safety Precautions 37
- Towing Information 38-39
- Trailer Hitch Connections 40
- Maintenance (Pump) 41-47
- Maintenance (Trailer) 48-50
- Wiring Diagram (Tail Lights) 51
- Wiring Diagram (Electrical) 52
- Wiring Diagram (Control Panel) 53
- Wiring Diagram (Terminal Blocks) 54
- Wiring Diagram (Terminal Blocks to Comp.) 55
- Wiring Diagram (Harness Connect) 56
- Wiring Diagram (Optional Hopper Vibrator) 57
- Hydraulic System Diagram 58
- Manifold Block Ports 59

- Appendix — Concrete Mix Information 61-62
- Appendix — Slump Test Procedure 63
- Appendix — Recommended
Shotcrete System 64-65
- Appendix — Recommended
Shotcrete Accessories 66-67
- Troubleshooting (Pump) 68-69
- Troubleshooting (Engine) 70
- Troubleshooting (Brake System) 71
- Explanation Of Codes In Remarks Column 72
- Suggested Spare Parts 73

COMPONENT DRAWINGS

- Name Plate and Decals 74-75
- Frame Assy. 76-77
- Axle Assy. 78-79
- Brake Line Assy. 80-81
- Brake Lights Assy. 82-83
- Trailer Hitch Assy. 84-85
- Battery Assy. 86-87
- Hopper Assy. 88-89
- Hopper Attachment Assy. 90-91
- Hopper Interior Assy. 92-93
- Shuttle Cylinder Assy. 94-97
- Lubrication Pistons Assy. 98-99
- Fuel Tank Assy. 100-101
- Heat Exchanger Assy. 102-103
- Accumulator Assy. 104-105
- Remixer Control Assy. 106-107
- Lubrication Panel Assy. 108-109
- Engine Cover Assy. 110-111
- Hydraulic Tank Assy. 112-113
- LS-60TD Engine Assy. 114-115
- LS-60TD Engine Air Cleaner Assy. 116-117
- Throttle Assy. 118-119
- Water Seperator Assy. 120-121
- Hydraulic Pump Assy. 122-123
- Manifold Assy. 124-125
- Control Box Assy. 126-127
- Control Box Harness Assy. 128-129
- Remote Control Cable Assy. 130-131
-
- Terms and Conditions of Sale - Parts 132
- Mayco Pump Warranty 133

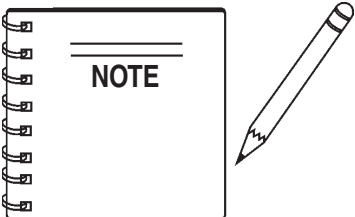

Specification and part number are subject to change without notice.

PARTS ORDERING PROCEDURES

When ordering parts, please supply the following information:

- Dealer account number
- Dealer name and address
- Shipping address (if different than billing address)
- Return fax number
- Applicable model number
- Quantity, part number and description of each part
- Specify preferred method of shipment:
 - ✓ FedEx or UPS Ground
 - ✓ FedEx or UPS Second Day or Third Day
 - ✓ FedEx or UPS Next Day
 - ✓ Federal Express Priority One
 - ✓ DHL
 - ✓ Truck

Note: Unless otherwise indicated by customer, all orders are treated as "Standard Orders", and will ship within 24 hours. We will make every effort to ship "Air Shipments" the same day that the order is received, if prior to 2PM west coast time. "Stock Orders" must be so noted on fax or web forms.



Here's how to get help...

Please have the model and serial number on hand when calling.

MULTIQUIP CORPORATE OFFICE

18910 Wilmington Ave. 800-421-1244
 Carson, CA 90746 FAX: 310-537-3927
 Email: mq@multiquip.com
 Internet: www.multiquip.com

PARTS DEPARTMENT

800-427-1244 FAX: 800-672-7877
 310-537-3700 FAX: 310-637-3284

MAYCO PARTS

800-306-2926 FAX: 800-672-7877
 310-537-3700 FAX: 310-637-3284

SERVICE DEPARTMENT

800-421-1244 FAX: 310-537-4259
 310-537-3700

TECHNICAL ASSISTANCE

800-478-1244 FAX: 310-631-5032

WARRANTY DEPARTMENT

800-421-1244, EXT. 279 FAX: 310-537-1173
 310-537-3700, EXT. 279

Place Your Parts Order Via Web or Fax For Even More Savings!

(Domestic USA Dealers Only)

Extra Discounts!

All parts orders which include complete part numbers and are received by our automated web parts order system, or by fax qualify for the following extra discounts:

Ordered via	Standard orders	Stock orders (\$750 list and above)
Fax	3%	10%
Web	5%	10%

Special freight allowances when you order 10 or more line items via Web or Fax! **

FedEx Ground Service **at no charge for freight**

No other allowances on freight shipped by any other carrier.

****Common nuts, bolts and washers (all items under \$1.00 list price) do not count towards the 10+ line items.**

NOTE: DISCOUNTS ARE SUBJECT TO CHANGE



MULTIQUIP INC.
 18910 WILMINGTON AVENUE
 POST OFFICE BOX 6254
 CARSON, CALIFORNIA 90749
 310-537-3700 • 800-421-1244
 FAX: 310-537-3927
 E-MAIL: mq@multiquip.com
 INTERNET: www.multiquip.com

Direct TOLL-FREE access to our Parts Department:

Toll-free nationwide — 800-427-1244

Toll-free FAX — 800-6-PARTS-7 (800/672-7877)

LS-60TD PUMP — SPECIFICATIONS

TABLE 1. PUMP SPECIFICATIONS

Model	LS-60TD
Pumping Rate	Up to 60 cu. yds. per hour*
Pumping Method	Reciprocating Piston
Maximum Aggregate Size	1-1/2 in. minus (38mm)
Vertical Pumping Height	Up to 250 ft. (76m)
Horizontal Pumping Distance	1000 ft. (305m)*
Cylinder Lubrication Box Capacity	2 Gallons (7.6 Liters)
Hydraulic Fluid Capacity	50 Gallons (189 Liters)
Fuel Tank Capacity	40 Gallons (76 Liters)
Hopper Capacity	10 cu. ft. with optional fwd/rev remixer
Material Hose	3 in., 4 in., 5 in. dia. (76.2mm, 101.6 mm, 127 mm)
Engine Model	Deutz Turbo Diesel BF4L914
Weight (with fluids)	5,190 lbs. (2,354 kg)
Weight (dry/shipping)	4,760 lbs. (2,159 kg)
Tire Size	7.35 in. x 14 in. (187 mm x 356 mm)
Options	Wireless Remote Control, Hopper Screen Vibrator
*Volume output will vary depending on mix design, slump, line size used and job site condititons	

TABLE 2. ENGINE SPECIFICATIONS

Model	Deutz BF4L914 Diesel Engine
Type	4 stroke, Air-cooled Diesel
No. of Cylinders	4
Bore x Stroke	4.19 in. x 5 in. (106 mm x 127 mm)
Rated Output	106 HP@ 2500 rpm
Displacement	167 cu. in. (2.73 L)
Starting	Electric 12VDC
Lube Oil Capacity	9.5 gal. (2.5 liters)
Fuel Type	#2 Diesel Fuel
Battery	12V BCI Group 27

LS-60TD PUMP — DIMENSIONS

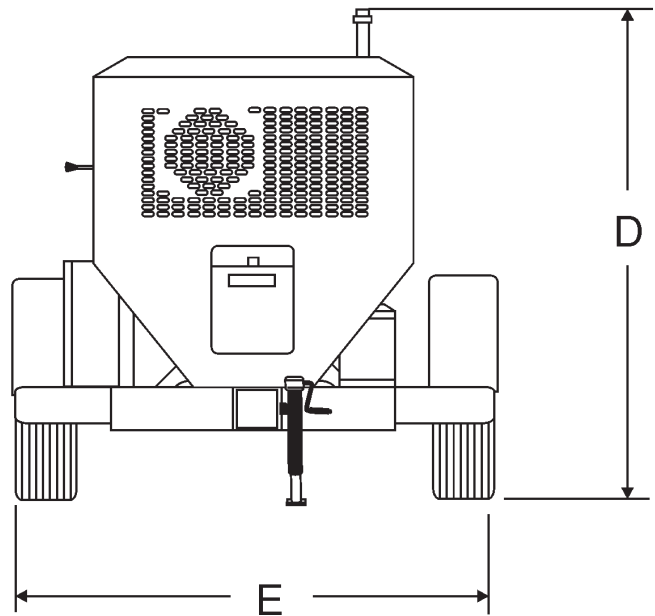
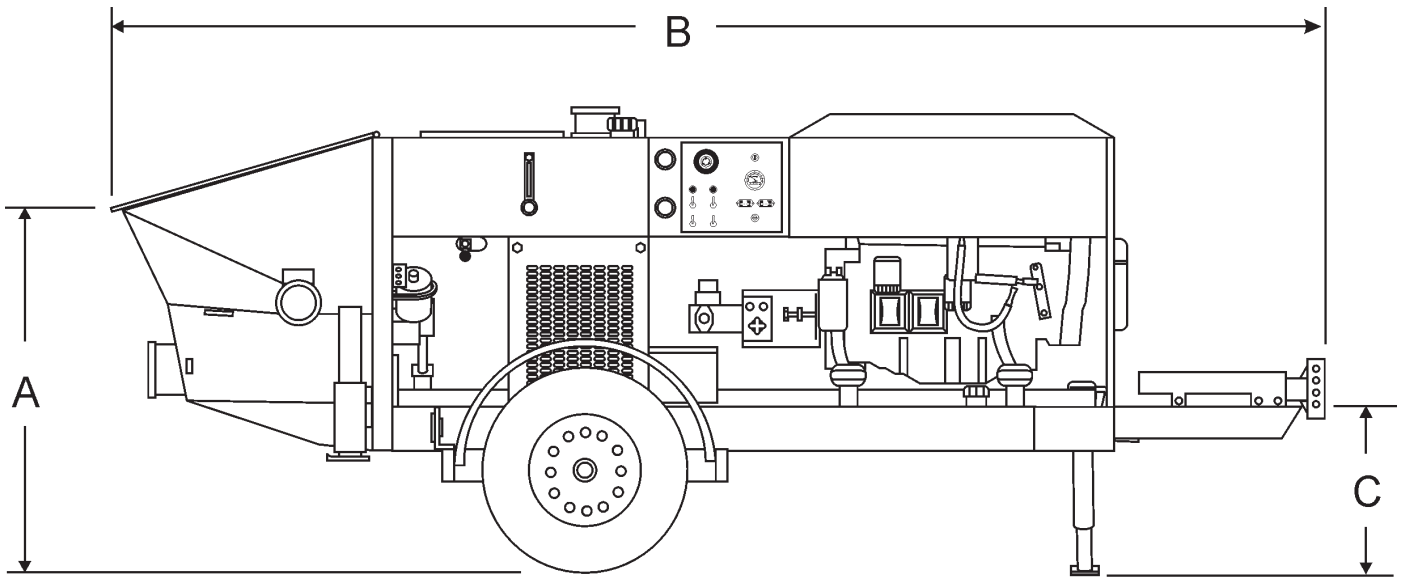

TABLE 3. DIMENSIONS

REF.	DIMENSIONS
A	45 in. (114.3 cm.)
B	149 in. (378 cm.)
C	24 in. (61 cm.)
D	54 in. (137 cm.)
E	68 in. (172.2 cm.)

Figure 1. Dimensions

LS-60TD PUMP — SAFETY MESSAGE ALERT SYMBOLS

FOR YOUR SAFETY AND THE SAFETY OF OTHERS!

Safety precautions should be followed at all times when operating this equipment. Failure to read and understand the Safety Messages and Operating Instructions could result in injury to yourself and others.

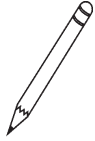
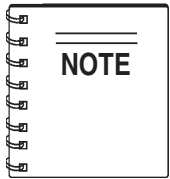

This Owner's Manual has been developed to provide complete instructions for the safe and efficient operation of the **Multiquip Mayco LS-60TD Structural Concrete** pump. Refer to the

engine manufacturers instructions for data relative to its safe operation.

Before using this pump , ensure that the operating individual has read and understands all instructions in this manual.

SAFETY MESSAGE ALERT SYMBOLS

The three (3) Safety Messages shown below will inform you about potential hazards that could injure you or others. The Safety Messages specifically address the level of exposure to the operator, and are preceded by one of three words: **DANGER**, **WARNING**, or **CAUTION**.

DANGER

You **WILL** be **KILLED** or **SERIOUSLY** injured if you do not follow directions.

WARNING

You **COULD** be **KILLED** or **SERIOUSLY** injured if you do not follow directions.

CAUTION

You **CAN** be injured if you do not follow directions

HAZARD SYMBOLS

Potential hazards associated with operation of the pump will be referenced with Hazard Symbols which appear throughout this manual, and will be referenced in conjunction with Safety Message Alert Symbols. Some examples are listed below:

WARNING - LETHAL EXHAUST GASES



Diesel engine exhaust gases contain poisonous carbon monoxide. This gas is colorless and odorless, and can cause death if inhaled. **NEVER** operate this equipment in a confined area or enclosed structure that does not provide ample free flow air.

WARNING - EXPLOSIVE FUEL



Diesel fuel is extremely flammable, and its vapors can cause an explosion if ignited. **DO NOT** start the engine near spilled fuel or combustible fluids. **DO NOT** fill the fuel tank while the engine is running or hot.

DO NOT overfill tank, since spilled fuel could ignite if it comes into contact with hot engine parts or sparks from the ignition system. Store fuel in approved containers, in well-ventilated areas and away from sparks and flames. **NEVER** use fuel as a cleaning agent.

WARNING - BURN HAZARDS



Engine components can generate extreme heat. To prevent burns, **DO NOT** touch these areas while the engine is running or immediately after operations. **NEVER** operate the engine with heat shields or heat guards removed.

LS-60TD PUMP — SAFETY MESSAGE ALERT SYMBOLS

WARNING - ROTATING PARTS



NEVER operate equipment with covers, or guards removed. Keep **fingers, hands, hair** and clothing away from all moving parts to prevent injury.

CAUTION - RESPIRATORY HAZARDS



ALWAYS wear approved **respiratory** protection.

CAUTION - ACCIDENTAL STARTING



ALWAYS place the **Engine ON/OFF** switch in the **OFF** position. **NEVER** perform maintenance on the unit with the ignition key in the **ON** position.

CAUTION - SIGHT AND HEARING HAZARDS

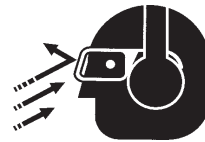

ALWAYS wear approved **eye** and **hearing** protection.

CAUTION - OVER-SPEED CONDITIONS



NEVER tamper with the factory settings of the engine governor or settings. Personal injury and damage to the engine or equipment can result if operating in speed ranges above maximum allowable.

CAUTION - EQUIPMENT DAMAGE MESSAGES

Other important messages are provided throughout this manual to help prevent damage to your concrete pump, other property, or the surrounding environment.

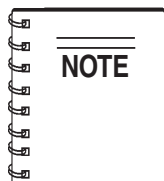

This **pump**, other property, or the surrounding environment could be damaged if you do not follow instructions.

LS-60TD PUMP — RULES FOR SAFE OPERATION

DANGER - READ OPERATION AND PARTS

Failure to follow instructions in this manual may lead to serious injury or even **death!** This equipment is to be operated by trained and qualified personnel only! This equipment is for industrial use only.

The following safety guidelines should always be used when operating the LS-60TD structural concrete pump:

GENERAL SAFETY

- **DO NOT** operate or service this equipment before reading this entire manual.



- This equipment should not be operated by persons under 18 years of age.

- **NEVER** operate this equipment without proper protective clothing, shatterproof glasses, steel-toed boots and other protective devices required by the job.



- **NEVER** operate this equipment when not feeling well due to fatigue, illness or taking medicine.

- **NEVER** operate this equipment under the influence of drugs or alcohol.



- **ALWAYS** check the machine for loosened threads or bolts before starting.

- **ALWAYS** wear proper **respiratory** (mask), **hearing** and **eye** protection equipment when operating the pump.

- Whenever necessary, replace nameplate, operation and safety decals when they become difficult read.

- Manufacture does not assume responsibility for any accident due to equipment modifications.

- **NEVER** use accessories or attachments, which are not recommended by Multiquip for this equipment. Damage to the equipment and/or injury to user may result.

- **NEVER** touch the hot exhaust manifold, muffler or cylinder. Allow these parts to cool before servicing engine or pump.

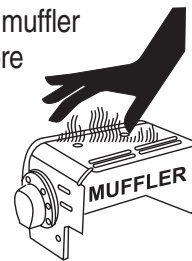

- **High Temperatures** – Allow the engine to cool before adding fuel or performing service and maintenance functions. Contact with **hot!** components can cause serious burns.

- The engine section of this pump requires an adequate free flow of cooling air. **NEVER** operate the pump in any enclosed or narrow area where free flow of the air is restricted. If the air flow is restricted it will cause serious damage to the pump or engine and may cause injury to people. Remember the pump's engine gives off **DEADLY** carbon monoxide gas.

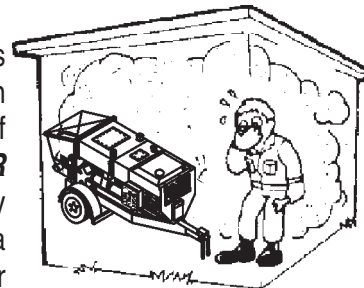

- **ALWAYS** refuel in a well-ventilated area, away from sparks and open flames.

- **ALWAYS** use extreme caution when working with **flammable** liquids. When refueling, **stop the engine** and allow it to cool.

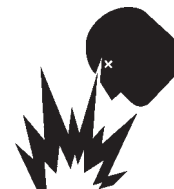

- **NEVER smoke** around or near the machine. Fire or explosion could result from **fuel vapors**, or if fuel is spilled on a **hot!** engine.



- **NEVER** operate the pump in an explosive atmosphere or near combustible materials. An explosion or fire could result causing severe **bodily harm or even death.**

- Topping-off to filler port is dangerous, as it tends to spill fuel.

- **ALWAYS** remove the **ignition key** when leaving the pump unattended.

- **ALWAYS block** the **wheels** on the unit when using on a slope.

- **ALWAYS** maintain this equipment in a safe operating condition at all times.

- **ALWAYS** stop the engine before servicing, adding fuel or oil.

LS-60TD PUMP — RULES FOR SAFE OPERATION

- **NEVER** run engine without air filter. Severe engine damage may occur.
- **ALWAYS** be sure the operator is familiar with proper safety precautions and operation techniques before using pump.
- **ALWAYS** store equipment properly when it is not being used. Equipment should be stored in a clean, dry location out of the reach of children.
- **DO NOT** operate this equipment unless all guards and safety devices are attached and in place.
- **CAUTION** must be exercised while servicing this equipment. Rotating and moving parts can cause injury if contacted.
- Keep all ***inexperienced*** and ***unauthorized*** people away from the equipment at all times.
- Before start-up, check the hopper and remove all foreign matter and debris.
- **DO NOT** use worn or damaged hose couplings, inspect all hoses and couplings for wear. Replace any worn or defective hose or couplings immediately.
- Keep hands out of the hopper when the engine is running.
- **DO NOT** operate unit with the ***hood open***.
- **DO NOT** disconnect hose couplings or nozzle while under pressure. Relieve pressure by manually activating pressure relief valve at manifold.
- Unauthorized equipment modifications will void all warranties.
- Check all fasteners periodically for tightness. Also check towing tongue bolt, lock nut and wheel lug nuts for wear.
- Test the ***pump's ON/OFF*** switch. The purpose of this test is to shut down the engine.
- Refer to the ***DEUTZ Engine Owner's Manual*** for engine technical questions or information recommended by Multiquip for this equipment. Damage to the equipment and or injury to user may result.

TRANSPORTING

- **ALWAYS** shutdown engine before transporting the pump.
- Tighten fuel tank cap securely and close fuel valve to prevent fuel from spilling.
- Drain fuel when transporting pump over long distances or bad roads.

Towing

- Before towing, check the hitch and secure the safety chain to the towing vehicle.
- When towing, an adequate safety chain must be fastened to the frame, refer to Towing Guidelines.
- Tow only with a vehicle and hitch rated to pull a 6,000 lbs. load.
- If unit is equipped with ball hitch coupler, use only 2" all steel ball rated for minimum of 6,000 lbs. Use 1" hardened steel pull pin, if not equipped with ball hitch.
- This equipment shall not be towed or operated by individuals who cannot read understand the signs, decals or operating instructions.
- When towing at night, ***always*** have rear tail lights **ON**.
- **DO NOT** tow unit with hopper full of material.
- **DO NOT** tow unit with hoses attached.
- **DO NOT** tow unit in excess of **55 MPH** on highways..

MAINTENANCE SAFETY

- **NEVER** lubricate components or attempt service on a running pump .
- **ALWAYS** allow the pump a proper amount of time to cool before servicing.
- Keep the pump in proper running condition.
- Fix damage to the pump immediately and always replace broken parts.
- Dispose of hazardous waste properly. Examples of potentially hazardous waste are used motor oil, fuel and fuel filters.
- **DO NOT** use plastic containers to dispose of hazardous waste.

LS-60TD PUMP — RULES FOR SAFE OPERATION

BATTERY

The battery contains acids that can cause injury to the eyes and skin. To avoid eye irritation, **always** wear safety glasses. Use well insulated gloves when picking up the battery. Use the following guidelines when handling the battery:

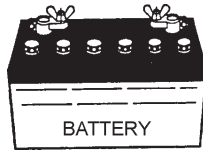

- **DO NOT** drop the battery. There is the possibility of risk that the battery may explode.
- **DO NOT** expose the battery to open flames, sparks, cigarettes etc. The battery contains combustible gases and liquids. If these gases and liquids come in contact with a flame or spark, an explosion could occur.
- **ALWAYS** keep the battery charged. If the battery is not charged a buildup of combustible gas will occur.
- **ALWAYS** keep battery charging and cables in good working condition. Repair or replace all worn cables.
- **ALWAYS** recharge the battery in an vented air environment, to avoid risk of a dangerous concentration of combustible gases.
- In case the battery liquid (dilute sulfuric acid) comes in contact with **clothing or skin**, rinse skin or clothing immediately with plenty of water.
- In case the battery liquid (dilute sulfuric acid) comes in contact with your **eyes**, rinse eyes immediately with plenty of water, then contact the nearest doctor or hospital, and seek medical attention.

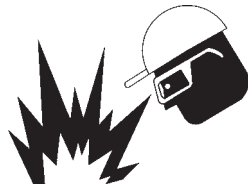

EMERGENCIES

- **ALWAYS** know the location of the nearest **fire extinguisher**.

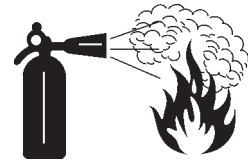

- **ALWAYS** know the location of the nearest and **first aid kit**.



- In emergencies **always** know the location of the nearest phone or **keep a phone on the job site**. Also know the phone numbers of the nearest **ambulance, doctor** and **fire department**. This information will be invaluable in the case of an emergency.



LS-60TD PUMP — OPERATION AND SAFETY DECALS

Machine Safety Decals

The LS-60TD structural concrete pump is equipped with a number of safety decals. These decals are provided for operator safety and maintenance information. Figure 2 below illustrates these decals as they appear on the machine. Should any of these decals become unreadable, replacements can be obtained from your dealer.

800-30-MAYCO

P/N: 511091



P/N: CIP515238 (SMALL)
P/N: CIP514666 (LARGE)

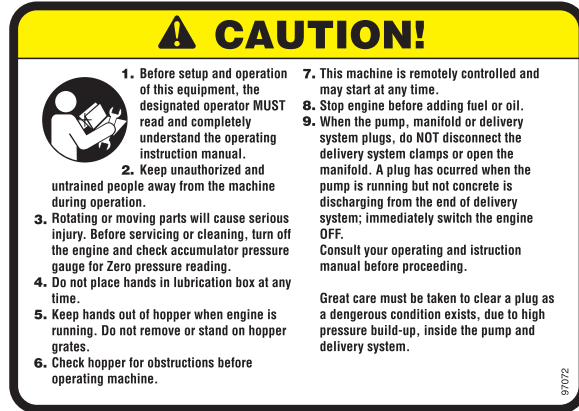

P/N: EM97072

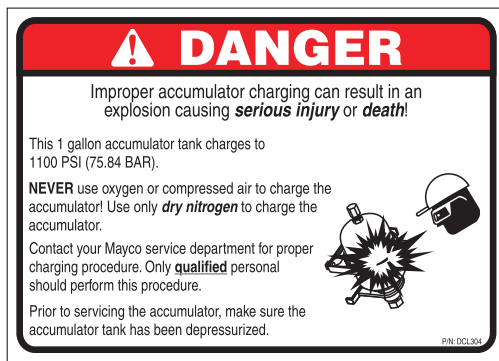

P/N: DCL304



P/N: DCL302

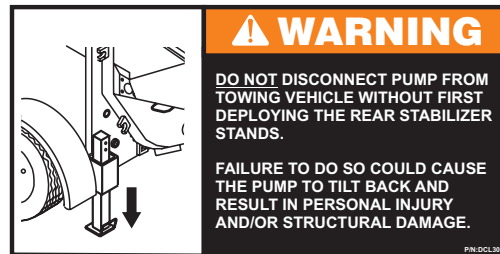

P/N: DCL305



P/N: 35137

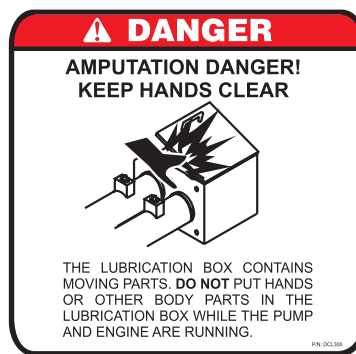

P/N: DCL300

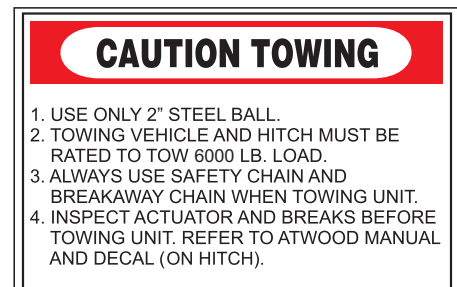

P/N: EM969

Figure 2. LS-60TD Operation and Safety Decals

LS-60TD PUMP — OPERATION AND SAFETY DECALS

MAINTENANCE

 **Grease daily:**

- Main hydraulic cylinders (2 places)
- Remix bearing (2 places)
- Axle crank bushing (1 place)
- Axle crank (1 place)

Grease type: Lithium based EP, Texaco multitak 20 or Lubriplate EP-2

Check daily:

- Main hydraulic reservoir. Use Shell Oil Tellus 68 or Mobil DFE26
- Lubrication box
- Diesel engine

Refer to operator manual for complete maintenance schedule.

P/N EM97084

WARNING

Explosion caused by improper accumulator charging can result in serious injury or death

- Follow charging instructions exactly (Refer to Service Manual)
- Never use Oxygen or compressed air to charge the accumulator
- Use only Dry Nitrogen to charge the accumulator

P/N: CIP97083

CAUTION

 Refer to manual for service instructions. Charge only with dry nitrogen.

P/N: EM955

CAUTION

MINIMUM OIL LEVEL

← Oil level below minimum can cause hydraulic pump and system damage. Oil temperature should not exceed 170°F (77°C)

P/N: EM97071

MODEL _____
SERIAL NO. _____

CONTACT PARTS DEPARTMENT

VOLUME CONTROL

INCREASE ← → DECREASE

P/N: EM985

ACCUMULATOR PRESSURE

P/N: EM97070

PUMPING PRESSURE

P/N: TBD



OWNER'S MANUAL

P/N: 345336

CAUTION

Grease every two hours of operation

P/N: EM98000

Engine RPM Setting (without change)

High RPM:	RPM
_____	_____
Low RPM:	RPM
_____	_____

P/N: CIP513580

HOPPER REMIXER

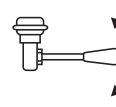
 PUSH TO OPERATE
NEUTRAL
PULL TO REVERSE

P/N: CIP972

CAUTION

 **USE DIESEL FUEL ONLY**
(Read Operator's book)

P/N: EM995

 **HYDRAULIC OIL ONLY**

P/N: CIP985

DANGER

AMPUTATION DANGER! KEEP HANDS CLEAR

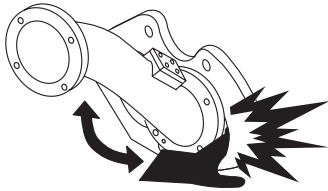

SHUTTLE TUBE PIVOTS RAPIDLY AND WILL CRUSH OR CUT. **DO NOT** PUT ANY BODY PARTS INTO THE HOPPER UNTIL MACHINE IS COMPLETELY SHUT DOWN AND THE ACCUMULATOR PRESSURE GAUGE READS **ZERO**

P/N: DCL301

Figure 2. LS-60TD Operation and Safety Decals (Continued)

LS-60TD PUMP — IMPORTANT HAND SIGNALS

Figure 3 display's the basic hand signals commonly used in concrete pumping operations.

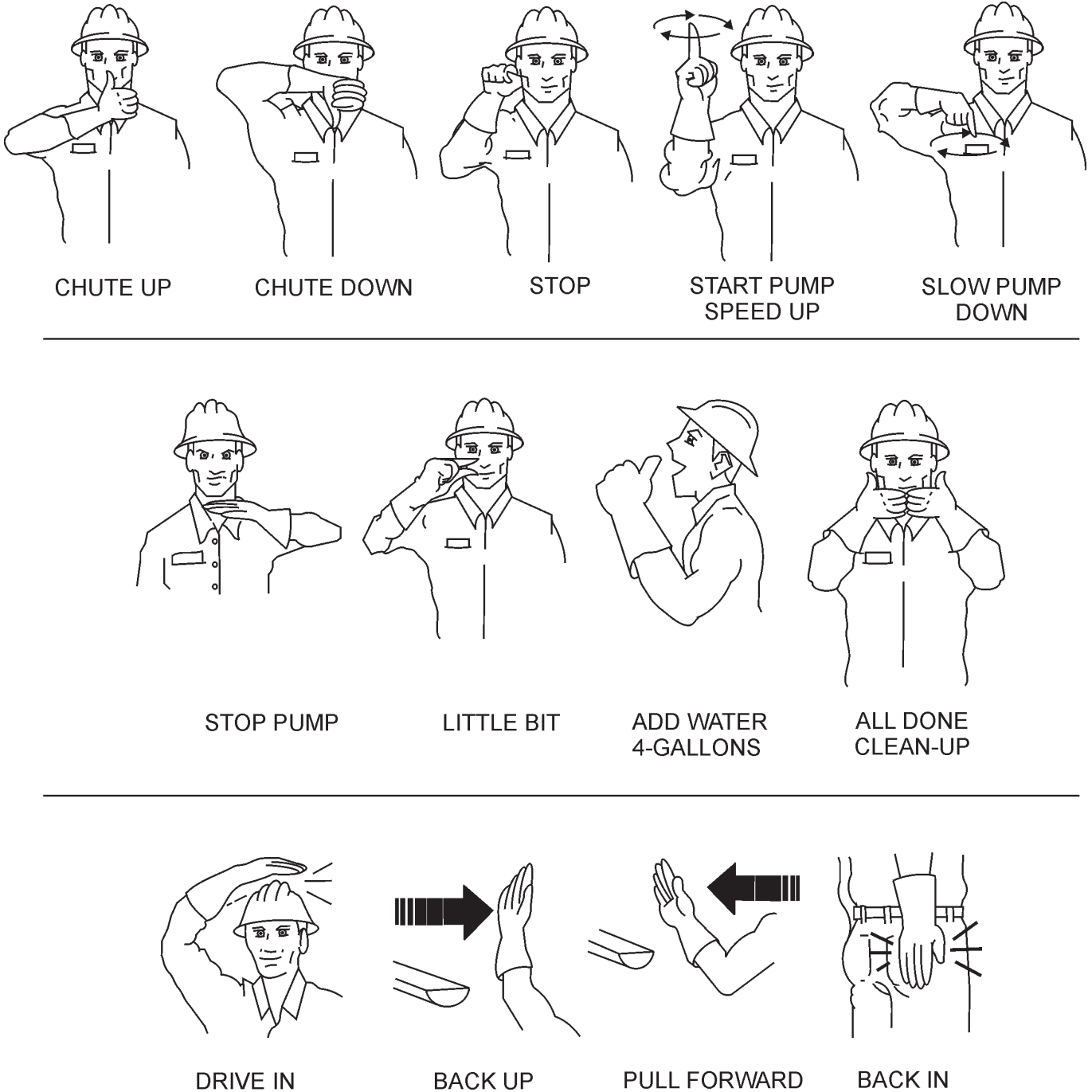

Figure 3 Operation Hand Signals

LS-60TD PUMP — GENERAL INFORMATION

CONCRETE MIX DESIGN

Mix design is most important to achieve maximum pumpability. Pumpability is affected by, among other factors, the type and gradation of aggregate used. Natural aggregates make a more workable mix and pump more readily than crushed aggregates. A blend of natural and crushed aggregates will produce a workable mix. The type and gradation of aggregates is equally important for workability as the size and percentage of coarse aggregates in the mix.

The term “aggregates” describes all of the solid materials, from the largest rock to the smallest grain of sand, contained in the concrete mix.

Concrete mixes with a consistency as dry as one-inch slump and as wet as ten-inch slump have been pumped; but for maximum efficiency from the pump, a slump ranging from two to six inches will produce a more workable mix than one that contains more or less water.

The principle of concrete pumping is based on self-lubrication. As it moves through the transfer line, the concrete takes the shape of a plastic cylinder. It is forced through the transfer line on a film of mortar that is self-troweled to the service of the transfer line around its full periphery by the slug of concrete itself.

A slump rating should be used with discretion; it is not always a real indication of the pumpability of the mix. The concrete may be workable in the sense that it will readily flow into place, but the same mix may not respond to pressure. Overly wet mixes tend to separate. In addition to affecting the strength and quality of the concrete, the delivery system will not tolerate separation. Overly dry mixes are similarly unsatisfactory if they lack plasticity and tend to be crumbly. To be properly pumped, the mix must be able to continuously coat the inside of the line with a lubricating seal of mortar.

There are four ways in which this seal can be lost:

1. By pumping excessively wet mixes which do not have enough cohesion to hold together.
2. By pumping harsh undersanded concrete with poorly graded aggregates which can jam together when the pressure becomes too great for the insufficient amount of sand to hold the aggregates apart.
3. By getting a rock pocket, such as mixer tailings, into the pump valve. This rock pocket will have an insufficient coating of mortar and the mix will not be plastic enough to allow the valve to operate or the mix to move in the line.
4. Through excessive bleeding. If the mix is short or fines, but the sand is otherwise fairly well graded, bleeding will not normally create any problems as long as the pump continues operation. But, if the pump is shut down, bleeding can result in a loss of lubrication and blocked erratic flow.

The above are bad concrete practices, regardless of how the mix is to be placed. But, these points do show that special mixes are not always needed, within limits, for pumping concrete. Good aggregate gradation is most important to pump concrete the maximum distance.

The use of admixtures can have a beneficial effect on pumpability. Most of the dispersing agents will fatten, retard bleeding, and increase workability. Thus, the average concrete can be pumped for appreciably longer distances. Air entraining agents will also improve workability, although they cannot be used as a substitute for good gradation of the aggregate. Pumping will not appreciably affect the final air content of the mix. High-early cement tends to give a more readily pumpable mix with superior water retaining qualities. However, if delays are likely to occur, extra care must be exercised due to the faster setting time over regular cement.

The Mayco LS-60TD models will pump a wide variety of concrete pump mixes. But, there are guidelines that must be followed. Use this information in conjunction with the **Operating Procedures** section of this manual.

LS-60TD PUMP — GENERAL INFORMATION

REGIONAL DIFFERENCES

Concrete is made by mixing locally available rock and sand with cement and water. For this reason there are great differences in the pumpability of concrete from one region of the country to another.

It is impossible to define a specific mix for each region that the concrete pump be will working in. Therefore, the mixes listed in **Appendix - Concrete Mix Information** will provide a basic guideline for establishing the proper mix design for your area.

Use this information to specify your requirements to your local ready-mix batch plant, contractor and civil engineer. It may take minor adjustments to make a mix pumpable, so you should explain your needs.

The elements that have to be controlled and consistently maintained by the batch plant are:

1. The sizing and mix percentage of rocks, gap graded from the largest down through the smallest sizes.
2. Sand with a sieve analysis that has the proper percentage of fines, ASTM C33 spec.
3. Sufficient cement to produce the required design strength of the concrete and provide the lubricating binder to pump the concrete through the delivery system.

Use a minimum of:

500 lbs. of cement/cu yd for 2500 p.s.i. concrete after 28 days.

530 lbs. of cement/cu yd for 3000 p.s.i. concrete after 28 days.

600 lbs. of cement/cu yd for 4000 p.s.i. concrete after 28 days.

4. Admixture pump-aid if necessary.

5. The proper amount of water to make a workable slump and plasticize the mix.

In addition, this Mayco Structural Concrete Pump can be used to pump a large aggregate hard rock as follows:

1. Pea rock (1/2" minus) pump with mixes being as low as 30% rock and 70% sand. (See page 44, for comments on cleaning the pump.)
2. Shortening pea rock when used with an air compressor and nozzle. (See back pages for recommended set-up.)
3. "Mud Jacking", high pressure grouting.

LS-60TD PUMP — HOW IT WORKS

The following is a brief explanation of how the concrete cylinders, hydraulic cylinders, shuttle tube, valves and hopper work in sequence to pump concrete.

The hydraulic pressure is generated by a variable volume, pressure compensated, axial piston pump that is driven by a diesel engine. The rod sides of the drive cylinders are hydraulically connected together creating a “slave circuit,” which allows hydraulic oil to transfer from one piston to the other.

The two part cycling sequence is initiated by an electrical signal generated by two proximity switches located in the drive cylinder. The proximity switches are normally open, magnetically sensing the movement of the main drive cylinder. As the drive cylinder piston head passes the proximity switch, an electrical signal is sent to the solenoid operated pilot valve which in turn directs pilot oil to the four valves controlling the drive cylinder and the shuttle cylinder.

A one-gallon accumulator assists the movement of the shuttle tube. This circuit assures that the shuttle tube will throw with the same intensity of each stroke regardless of how fast the main drive cylinders are cycling.

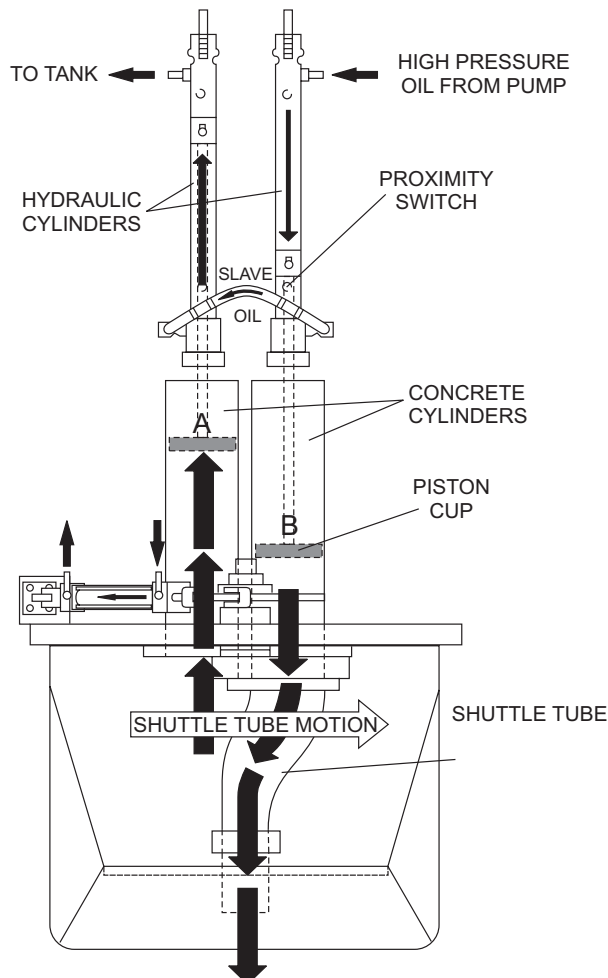

Figure 4. Pumping Cycle 1

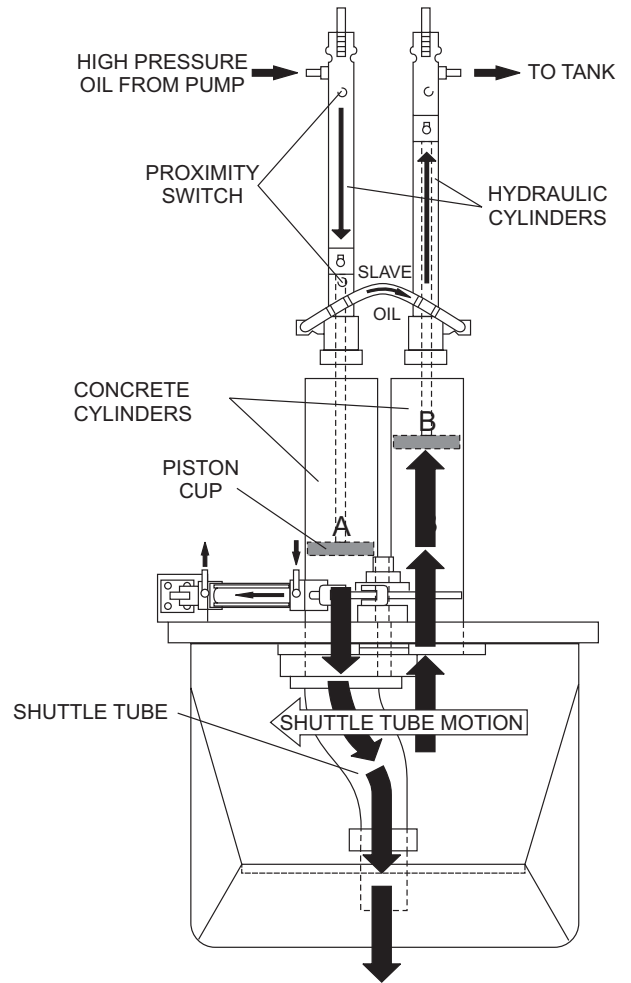

Figure 5. Pumping Cycle 2

In the first cycle, hydraulic pressure is applied to cylinder (B), causing the hydraulic piston, which is connected to the concrete piston and piston cup, to discharge concrete into the delivery line (Figure 4).

As one cylinder is discharging concrete, the hydraulic oil from the rod side (B) of the drive cylinders is being transferred through the slave circuit causing the opposite cylinder (A) to move back on the suction stroke, filling the cylinder with concrete.

The shuttle tube is sequenced to pivot to each concrete cylinder as the drive cylinders stroke to push concrete. As the second cycling sequence begins (Figure 5), the shuttle tube pivots to the opposite cylinder (A). The hydraulic piston passes under the proximity switch and sends pressure to the piston, causing it to stroke and discharge concrete into the delivery line. Hydraulic oil is transferred through the slave circuit to cylinder B, causing it to start a suction stroke, refilling it with concrete. The pumping sequence then repeats for the duration of the operation.

LS-60TD PUMP — PUMP COMPONENTS

Figure 6 illustrates the location of the major components for the LS-60TD Structural Concrete Pump. The function of each component is described below:

1. **Tow Hitch Coupler** – Requires a 2-inch ball hitch or a 3-inch pintle. Capable of towing 6,000 lbs.
2. **Documentation Box** – Contains engine and pump operation, parts and maintenance information.
3. **Manifold Access Door** – Turn handle and lift door to access the Hydraulic Manifold Block.
4. **Hydraulic Manifold Block** – Aluminum block that controls the flow of hydraulic pressure to the components required to control the pump.
5. **Hopper Discharge Sleeve** – Connect hoses or steel pipes to the discharge sleeve for pouring concrete.
6. **Pump End Jack Stand** – Use this jack stand to level and support the rear end of the pump. **NEVER** deploy on un-level ground and always check for firmness of ground.
7. **Shuttle Cylinder** – Under pressure, the shuttle cylinder shears concrete passing from the concrete cylinder to the delivery line during the cycle phase.

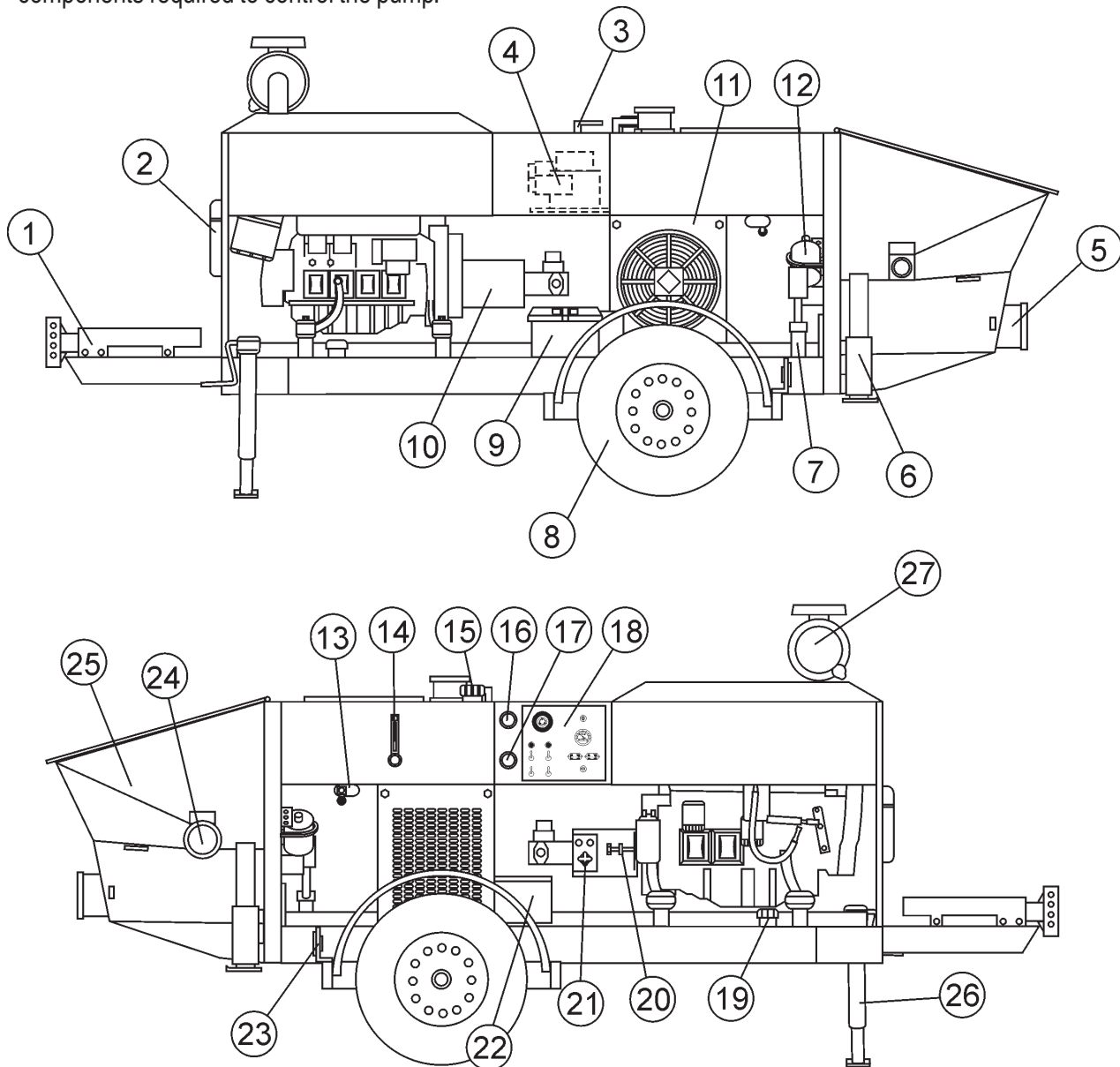
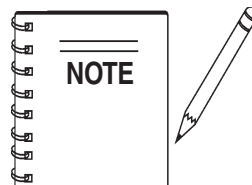

Figure 6. Major Pump Components

LS-60TD PUMP — PUMP COMPONENTS

8. **Tires** — This trailer uses two ST205-750 x15E type tires. Tire inflation pressure is the most important factor in tire life. Pressure should be checked to **50 psi cold** before operation. **DO NOT** bleed air from tires when they are hot. Check inflation pressure weekly during use to insure the maximum tire life and tread wear.
9. **Battery** – This unit uses a +12 VDC type battery. **ALWAYS** use gloves and eye protection when handling the battery.
10. **Hydraulic Pump** – This unit incorporates an axial variable displacement hydraulic piston pump.
11. **Heat Exchanger** – Reduces temperature of the hydraulic oil. The exchanger draws oil from the hydraulic tank through a filter and into the heat exchanger before allowing it to flow into the hydraulic system.
12. **Accumulator** – Stores hydraulic oil under pressure and releases it to the shuttle cylinder and provides the pressure needed to ensure enough force is provided during cycle.
13. **Remixer Control Lever** – Controls the forward/reverse motion of the hopper remixer paddles.
14. **Hydraulic Oil Sight Glass** – Use to determine the amount of hydraulic oil remaining in tank. The sight glass also contains a temperature gauge for monitoring the temperature of the hydraulic oil.
15. **Hydraulic Oil Tank/Cap**– Remove cap to add hydraulic fluid. Fill with Shell Oil Tellus 68 or Mobil Oil DFE26 if level is low.
16. **Accumulator Pressure Gauge**– Used to monitor accumulator pressure. Pressure should read at least 1750 psi for correct pump operation.
17. **Pumping Pressure Gauge** – Used to monitor pressure in the concrete cylinders and shuttle tube.
18. **Control Box** – Contains the electrical components required to run the pump. See Control Box Components section for component callouts.
19. **Fuel Tank/Cap** – Fill with diesel fuel. Fuel tank (cell) holds approximately 40 gallons (176 liters). **DO NOT** top off fuel. Wipe up any spilled fuel immediately
20. **Throttle Control Knob** – This is a variable speed type control. Turning the throttle lock (CCW) left unlocks the throttle allowing the throttle control cable to be pulled out to the desired position. Once the desired throttle position (speed) has been achieved, turning the throttle lock to the (CW) right locks it in place. Use the fine tune adjustment knob to fine tune the engine rpm's.
To place the engine in idle, press the top button inward all the way..
21. **Stroke Volume Control Dial** – Turns CW/CCW to increase or decrease the number of strokes per minute of the pump.
22. **Lubrication Box** – This box is empty when shipped from the factory. Please fill with 3 gallons (11.35 liters) of SAE 30 motor oil for first time use. Also check the dual clean-out point on bottom of lubrication box for a secure tight fit.
23. **Rear Running Lights** – **ALWAYS** check and make sure both the right and left running lights are functioning correctly before towing the pump.
24. **Remixer Motor** – Drives the remixer paddles inside the hopper. The motor direction is controlled by the remixer control lever.
25. **Hopper/Hood** – Lift hood to fill. Concrete from a Redi-Mix truck is poured into this hopper. The hopper can hold 10 cu. ft of concrete with optional forward/reverse mixer. **NEVER** put hands or any other parts of you body into the hopper.
26. **Tow End Jack Stand** – Use this jack stand to level and support the tow end of the pump.
27. **Air Filter** – Prevents dirt and other debris from entering the fuel system. Release the latches on the side of the air filter cover to gain access to the filter element.



Operating the engine without an air filter, with a damaged air filter, or a filter in need of replacement will allow dirt to enter the engine, causing rapid engine wear.

LS-60TD PUMP — CONTROL BOX COMPONENTS

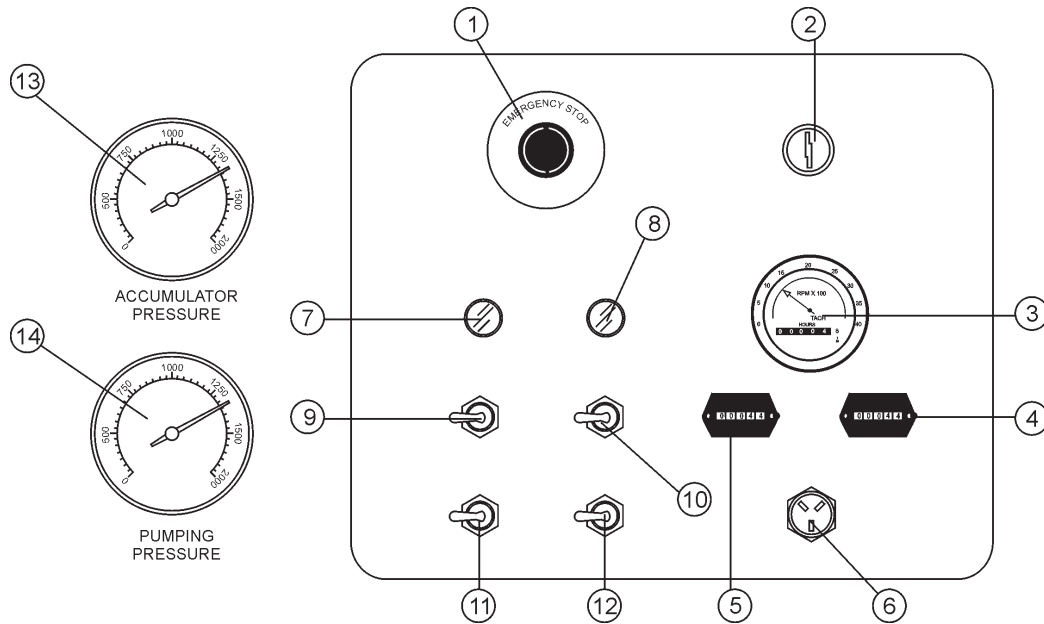

Figure 7. Pump Control Box Components

1. **Emergency Stop Button** – Press emergency stop button to stop pump in an emergency. Turn knob counter clockwise to disengage the stop button.
2. **Ignition Switch** – Insert the ignition key here to start the engine. Turn the key clockwise to the **ON** position, then continue turning clockwise to the **START** position and release. To stop the engine turn the key fully counter-clockwise to the **STOP** position.
3. **Engine Tachometer** – Monitors the engine RPM's and hours of operation for the engine.
4. **Engine Hour meter** – Display's the number of hours the engine has been in use.
5. **Pump Hour meter** – Display's the number of hours the pump has been in use.
6. **Remote Cable Connector** – Insert the remote control input cable into this connector.
7. **Battery Indicator Lamp**– Indicates a low battery charge. Replace or charge battery. **NEVER** operate the pump when this lamp is on.
8. **Oil Pressure Indicator Lamp** – Indicates incorrect operational pressure for running the pump. **NEVER** operate the pump if this lamp is **ON**.
9. **Direction Control Switch**– This 2 position switch controls the direction of flow for any mix in the pump. The **left most** position sets the pumping direction to forward and the **right most** position sets the pumping direction to reverse.
10. **Pumping Control Switch** – This 3-position switch controls the pumping of the pump. The **right most** position is for use with the remote control unit, the **left most** position is for normal pumping operation, and the **center most** position (OFF) prevents pumping.
11. **Cylinder Stroke Control Switch** - This three position switch controls the pumping function. The **left most** position sets the pump to **automatic cycling**. Set the switch to this position for normal pump operation. The **right most** position changes the pump from automatic to **manual cycling**. This allows the cylinders to be manually cycled using the **Manual Cylinder Jogging Switch**.
12. **Manual Cylinder Jogging Switch** – This 2 position switch allows the operator to manually jog the cylinders to assist in clearing material line packs and is used to test pumping pressure (See **Initial Start-up Procedure** section of this manual for testing procedure). The **left most** position jogs Cylinder "A" and the **right most** position jogs Cylinder "B".
13. **Accumulator Pressure Gauge** - This gauge monitors the internal pressure of the Accumulator tank. Normal internal pressure should read approximately 1750 PSI during pumping.
14. **Main Pressure Gauge** - This gauge monitors the system pressure while pumping material. The maximum pressure rating is 3200 PSI ± 50.

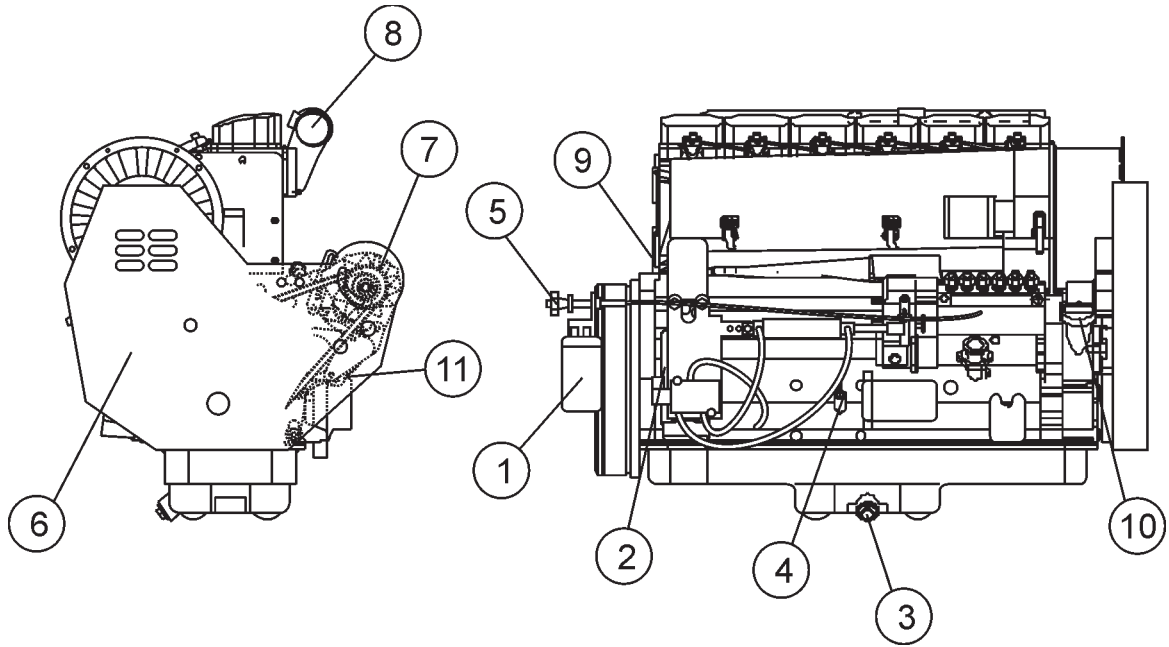

Figure 8. Deutz BF4L914 Diesel Engine Components

The engine (Figure 8) must be checked for proper lubrication and filled with fuel prior to operation. Refer to the manufacturers Engine manual for instructions & details of operation and servicing.

1. **Fuel Filter/Water Separator** – Service the fuel filter as recommended in the maintenance section of this manual.
2. **Oil Filter** – Prevents dirt and other debris from entering the engine. Service the oil filter as recommended in the maintenance section of this manual.
3. **Crankcase Drain Plug** – Remove this plug to drain engine oil from the engine crankcase. For best results drain engine oil when oil is warm.
4. **Dip Stick** – Remove dipstick to determine if the engine oil level is low. If low add oil as specified in Table 4.
5. **Engine Throttle Knob**– This is a variable speed type control. Turning the throttle lock (CCW) left unlocks the throttle allowing the throttle control cable to be pulled out to the desired position. Once the desired throttle position (speed) has been achieved, turning the throttle lock to the (CW) right locks it in place.
6. **V-Belt Cover** – Remove this cover to gain access to the V-belt. When replacing V-belt, use only recommended type V-belt.

7. **Alternator** – Provides power to the electrical system. Replace with only manufacturers recommended replacement parts.
8. **Air Intake** – Attach the Air Filter Hose to the Air Intake. See Pump Components, Item 27.
9. **Muffler** – Used to reduce noise and emissions. **NEVER** touch the muffler while it is hot! Serious burns can result. **NEVER** operate the engine with the muffler removed.
10. **Oil Filler Port/Cap** – Remove this cap to add engine oil to the crankcase. Fill with recommended type of oil as specified in the maintenance section of this manual.
11. **Starter/Solenoid** – This engine uses a 12 VDC, 2.7kW (3.7 HP) starter motor with solenoid.



LS-60TD PUMP — INSPECTION

⚠ CAUTION - GENERAL SAFETY GUIDELINES

NEVER operate the pump in a confined area or enclosed area structure that does not provide ample *free flow of air*.

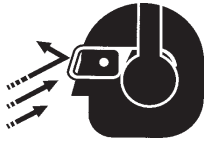

ALWAYS wear approved **eye** and **hearing** protection before operating the pump.

NEVER operate the pump's engine with the engine hood removed. The possibility exists of **hands, long hair,** and **clothing** becoming entangled with the V-belt, causing injury and bodily harm.



NEVER place hands or feet inside the **hopper**. **ALWAYS** make while the engine is running. **ALWAYS** shut-down the engine before performing any kind of maintenance service on the pump.



See Figures 6, 7, 8 for the location of any control or component referenced in this section.

BEFORE STARTING

1. Read safety instructions at the beginning of manual.
2. Clean the **entire pump**, removing dirt and dust, particularly the engine cooling air inlet, and heat exchanger.
3. Check the **air filter** for dirt and dust. If air filter is dirty, replace air filter with a new one as required.
4. Check fastening nuts and bolts for tightness.



⚠ WARNING - EXPLOSIVE FUEL

Handle fuel safely. Diesel fuel is highly **flammable** and can be dangerous if mishandled. **DO NOT smoke** while refueling. **DO NOT** attempt to refuel mixer if the engine is hot or running. **ALWAYS** allow engine to **cool** before refueling.

FUEL CHECK

5. Check the fuel gauge built into the fuel tank cap (Figure 9) to determine if the pump's engine fuel is low. Refuel as needed

⚠ WARNING - EXPLOSIVE FUEL



Diesel fuel is extremely flammable, and its vapors can cause an explosion if ignited. **DO NOT** start the engine near spilled fuel or combustible fluids. **DO NOT** fill the fuel tank while the engine is running or hot.

DO NOT overfill tank, since spilled fuel could ignite if it comes into contact with hot engine parts or sparks from the ignition system. Store fuel in approved containers, in well-ventilated areas and away from sparks and flames. **NEVER** use fuel as a cleaning agent.

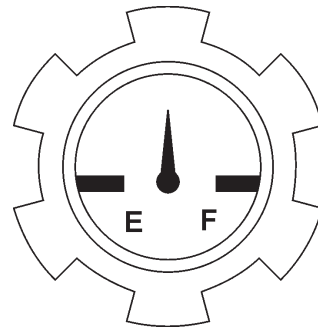

Figure 9. Fuel Cap Gauge

6. If fuel is low, remove fuel filler cap and fill with #2 **diesel fuel** (Figure 10).

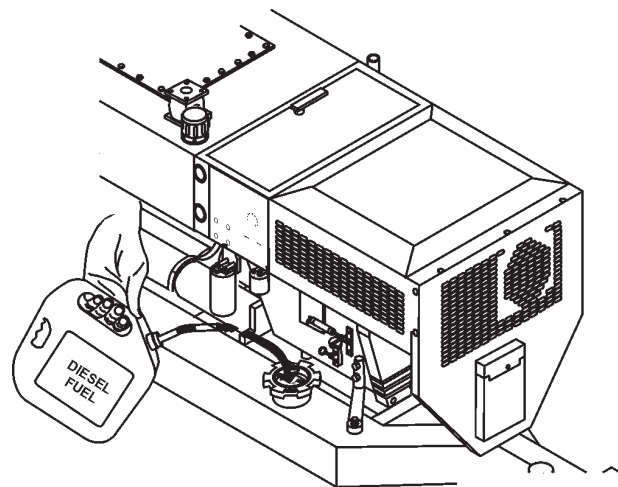

Figure 10. Adding Diesel Fuel

ENGINE OIL CHECK

- Remove the engine oil dipstick from its holder (Figure 11).

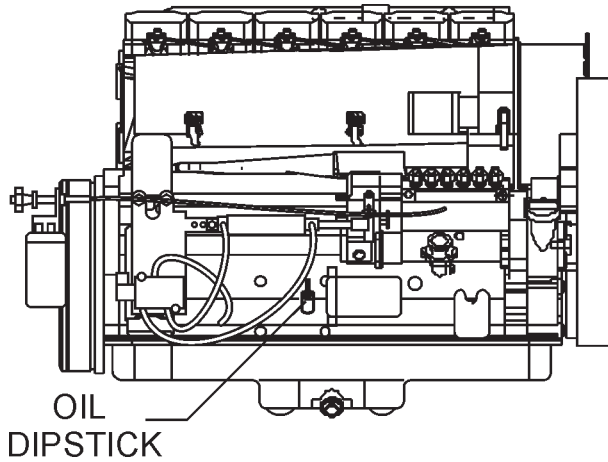

Figure 11. Engine Oil Dipstick

- Make sure pump/engine is placed on level ground.
- Pull the engine oil dipstick (Figure 12) from its holder.

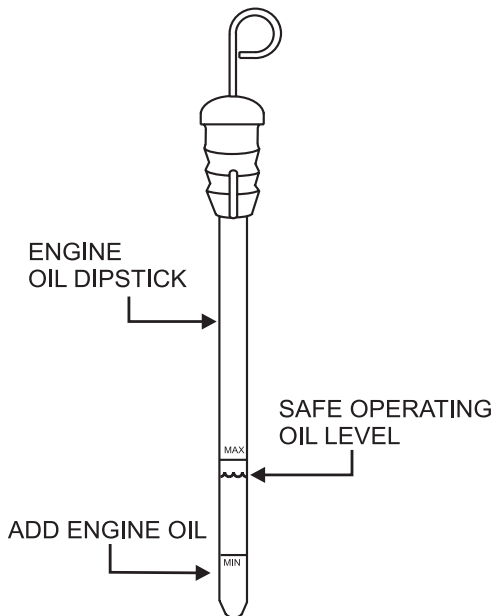
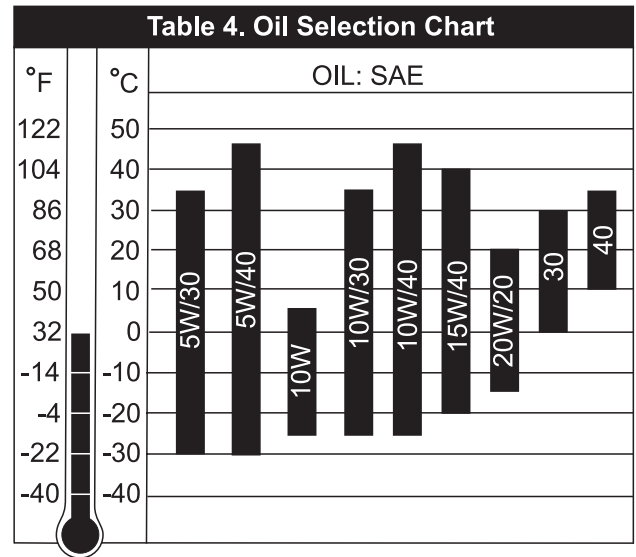

Figure 12. Engine Oil Dipstick

- Verify that oil level (Figure 12) is maintained between the two notches on the dipstick.
- If the pump's engine oil is low, fill engine crankcase with lubricating oil through filler hole, but **DO NOT** overfill.

- The oil listed in Table 4 is recommended to ensure better engine performance. Use class CD or higher grade motor oil.



HYDRAULIC OIL CHECK

- Determine if the hydraulic oil level is low by observing the level of the oil in the **Hydraulic Oil Sight Glass** (Figure 13).

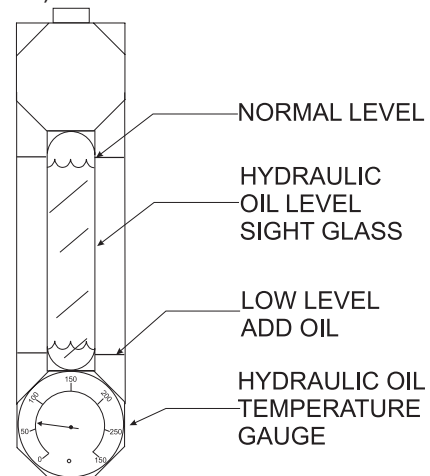

Figure 13. Hydraulic Oil Sight Glass

LS-60TD PUMP — INSPECTION

14. If the hydraulic oil level is low, remove the cap just above the oil level sight glass (Figure 14) and add the correct amount of hydraulic oil to bring the hydraulic oil level to a normal safe operating level. (Use Shell oil Tellus 68 or Mobil oil DFE26).

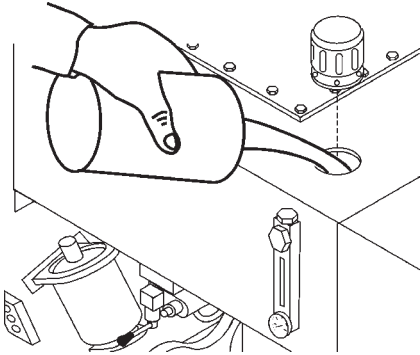

Figure 14. Hydraulic Oil Filler Hole

15. Check the oil level in the **lubrication box**. If low, fill with up to 3 gallons of SAE #30 motor oil (Figure 15). The oil level must be checked daily. The lubrication box should be serviced as described in the maintenance section.

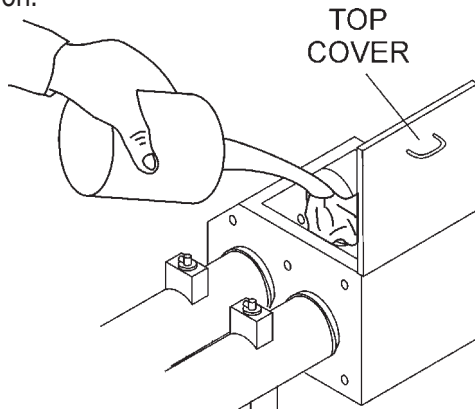

Figure 15. Filling the Lubrication Box

REAR STABILIZER STAND

To reduce excessive vibration and rocking of the pump, set the rear stabilizers as follows:

15. Locate both the left and right rear stabilizer stands (Figure 16).

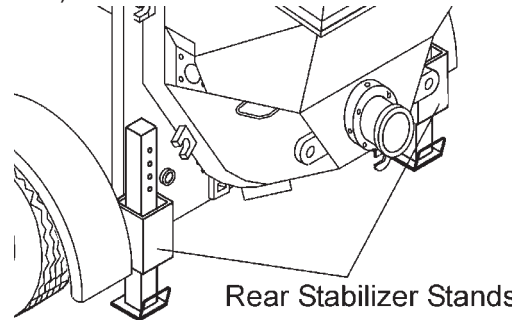

Figure 16. Locating Rear Stabilizer Stands

16. Remove the **cotter pin** from the handle tee bolt eye, and then **pull** the handle tee to release the stabilizer stand (Figure 17).
17. Position both rear stabilizer stands on firm (not loose) **level** ground (Figure 18).
18. Align the hole on the stabilizer stand with the hole on the frame body and **insert** handle tee bolt.
19. Insert the cotter pin into handle tee bolt eye to lock the stabilizer stand.

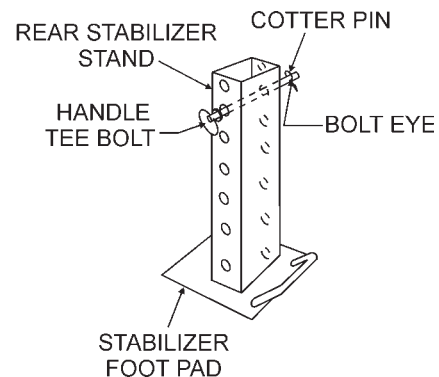

Figure 17. Rear Stabilizer Stand

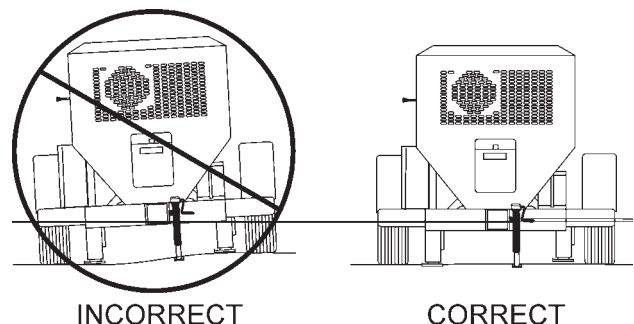

Figure 18. Rear Stabilizer Stand Deployment

LS-60TD PUMP — START-UP PROCEDURE

STARTING PROCEDURE

! WARNING - GENERAL SAFETY GUIDELINES

DO NOT attempt to operate this concrete pump until the Safety, General Information and Inspection sections have been read and understood.

1. Place all switches on the Control Box in the **OFF** position.
2. Locate the Emergency Stop Switch (Figure 19) on the Hydraulic Pump Control Box. Turn the Emergency Stop switch counter-clockwise (open). This will allow the engine to start.



Figure 19. Emergency Stop Switch

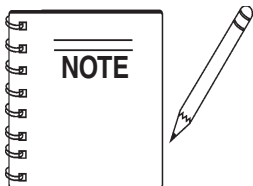

If the Emergency Stop switch is in the **CLOSED** position (stop), engine will not start. To start the engine, make sure the Emergency Stop switch is in the **OPEN** position (fully extended).

3. To start the engine, insert the key (Figure 20) into the ignition switch and turn the key to the **ON** position.

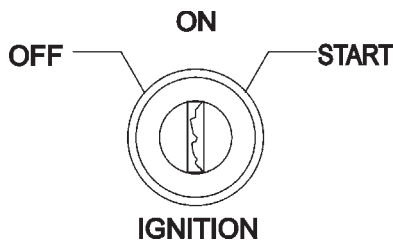

Figure 20. Ignition Switch

4. Observe that the **Battery** and **Oil Pressure** status indicator lights are **ON** (Figure 21).

BATTERY



OIL



Figure 21. Status Indicator Lights

- A. Turn the key to the **START** position and listen for the engine to start.
- B. In warm weather let engine warm-up for 5 minutes. In cold weather let engine warm-up for 10 minutes.
- C. The **Oil Pressure** and **Battery indicator** lights (Figure 21) should be **OFF**.

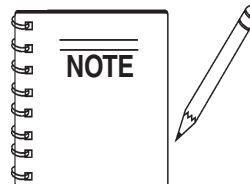

If any of the status indicator lights referenced in the ignition section (step 4) are **ON**, turn off the engine. **DO NOT** continue to run the engine.

5. Turn the **Cylinder Stroke Control switch** (Figure 22) to the **AUTOMATIC** position.

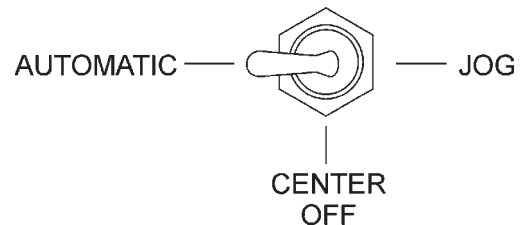

Figure 22. Cylinder Stroke Control Switch (Automatic)

6. Place the **Pumping Control Switch** to the **ON** position (Figure 23) for normal pumping operation. Place the switch in the **REM.** position for remote control operation of the LS-60TD pump.

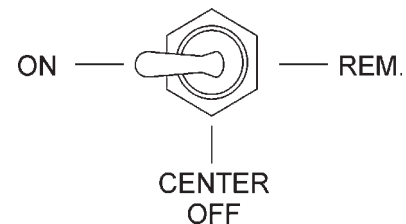

Figure 23. Pumping Control Switch (On)

LS-60TD PUMP — START-UP PROCEDURE

7. Turn the Volume Control (Figure 24), **lock nut** counterclockwise (CCW) to release the volume control knob.

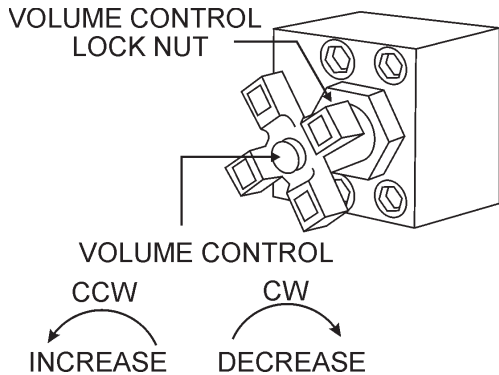

Figure 24. Volume Control

8. Use the volume control, to set the pump volume to approximately **10 strokes per minute**. Turning the volume control clockwise (CW) will **decrease** pump volume, and counterclockwise (CCW) will **increase pump** volume.

A **thumping** sound (cylinder stroke) should be heard. The thumping sound represents the number of strokes per minute (volume) of the pump.

9. Let the pump cycle until the hydraulic oil temperature (Figure 25) is approximately 50 to 60 degrees fahrenheit.

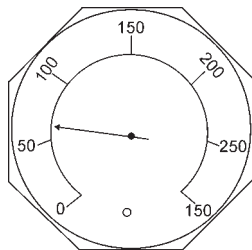

Figure 25. Hydraulic Oil Temperature Gauge

10. While monitoring the tachometer, (Figure 26) use the Engine Throttle Control to set the engine speed to 2550 RPM by following steps 10A-10C.

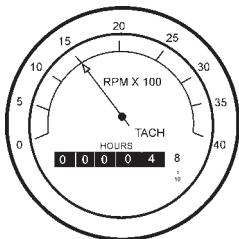

Figure 26. Engine Tachometer

- A. Unlock the throttle cable. To unlock the throttle cable, turn the inner most knob counter clockwise (Figure 27.)

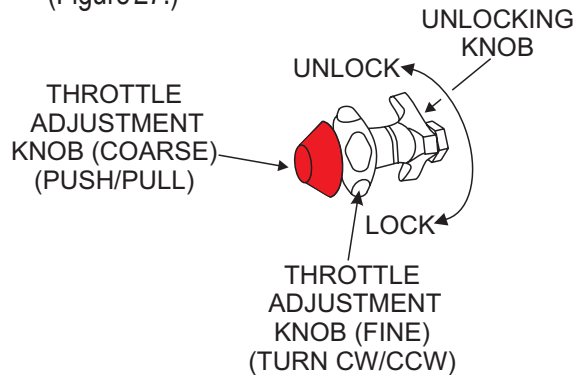

Figure 27. Throttle Control Knob (Un-locking)

- B. Push the outermost button (coarse adjustment) inward, then pull outward until engine RPM reaches desired speed (Figure 28).
- C. Turn the unlocking knob (figure 28) clockwise to lock engine RPM in place.

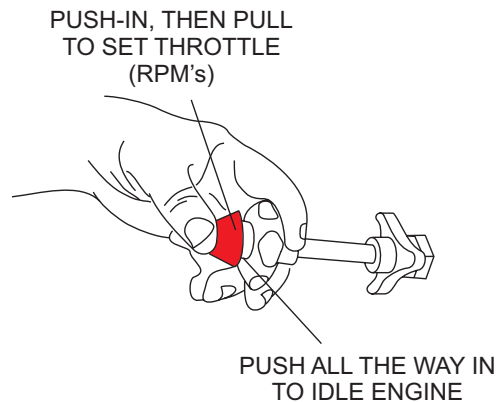
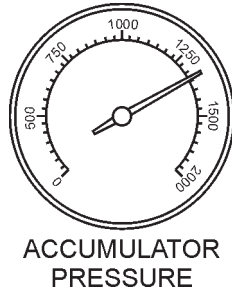

Figure 28. Throttle Control Knob (RPM Adjust)

LS-60TD PUMP — START-UP/SHUT-DOWN PROCEDURE

11. The **Accumulator Pressure Gauge** (Figure 29) should read approximately 1750 pounds per square inch (psi).

Figure 29. Accumulator Pressure Gauge



EMERGENCY SHUTDOWN PROCEDURE

In the event of an emergency, to shut down the pump:

1. Depress the **Emergency Stop Switch** (Figure 19)

12. Turn the **Cylinder Stroke Control switch** to the **OFF** position (Figure 30). The pump is now ready to be operated. Refer to the **Operating Procedures** section of this manual for priming and operating instructions.

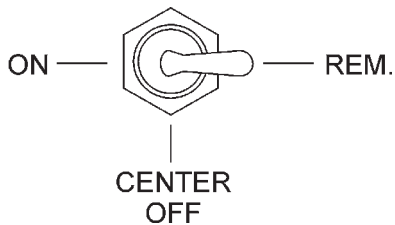

Figure 30. Pumping Control Switch (Off)

LS-60TD PUMP — OPERATING PROCEDURES

OPERATING PROCEDURES

WARNING - SAFETY GLASSES



Safety glasses **MUST** be worn at all times when operating the pump. Failure follow safety guidelines can result in **serious** injury.

NOTE

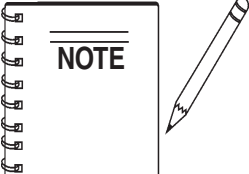

A well-planned location of the pump and routing of the hose before starting a pour may save subsequent moves throughout the job.

PRESSURE TEST

- To determine the pressure of the Hydraulic System, set the **Cylinder Stroke Control switch** (Figure 31) to the **JOG** position.

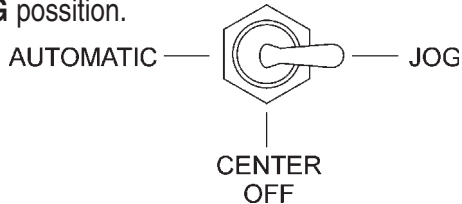

Figure 31. Manual Cylinder Jogging Switch

- Turn and hold the **Manual Cylinder Jogging Switch** (Figure 32) to either **JOG "A"** or **JOG "B"** position to test the pressure of that cylinder.



Figure 32. Manual Cylinder Jogging Switch

- The Pumping Pressure Gauge (Figure 33) should read approximately 3200 ± 50 PSI.

Figure 33. Pumping Pressure Gauge

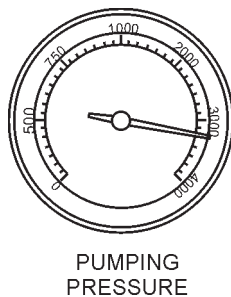

HOSE LUBRICATION

This procedure lubricates the hose and prevents separation and blockages in the hose. **Inspect the lines at all times to prevent problems.**

Before concrete is discharged into the hopper, it is suggested that 3 to 4 gallons of water be sprayed into the hopper, followed by approximately 5 gallons of a creamy cement and water slurry (1/2 bag of cement to 5 gallons of water).

NOTE

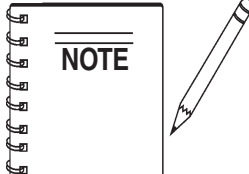

Getting the concrete to flow through the hose at the start of the pumping cycle can be one of the most critical operations of the pour. (**Manually** operate the throttle when starting, **NOT REMOTELY**)

PRIMING THE PUMP WITH SLURRY MIXTURE

It is **CRITICAL** to the successful operation of a concrete pump that the manifold and all delivery hoses, pipes and elbows are coated with a film of lubrication **BEFORE** you attempt to pump concrete.

Failure to properly prepare the pump and system will result in a "dry pack" of concrete, blocking the shuttle valve tube or delivery line.

- Connect the entire delivery system to the pump, **except** for the first hose. Pour 5 gallons of water into the second hose and push in your clean out ball and reconnect. This will help hold back the prime.
- There are several things you can use for the prime. A few examples are Cement and lime at a 50/50 mixture, slick pac, bentonite clay.

NOTE

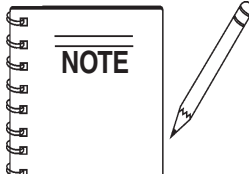

The bentonite is not compatible with concrete. **DO NOT** pump it into the forms discharge it out of the formed area.

- Mix the prime to the consistency of a smooth batter.
- Position the first ready-mix truck at the hopper. Check the concrete. **DO NOT** discharge concrete into hopper at this time.
- Pour approximately two 5 gallon buckets of prime into the first hose and connect it to the pump.

LS-60TD PUMP — OPERATING PROCEDURES

6. With the pump in **FORWARD** at 25-30 strokes per minute, slowly discharge the concrete from the ready-mix truck into the hopper and completely fill it. Keep the pump running continuously until concrete is discharging at the end of the delivery system. If the pump is stopped during this procedure, a blockage may occur.

CAUTION - HOSE/LINE BLOCKAGE

If hoses or lines are **blocked** for any reason, or if the lines are **kinked** when starting up or during the pumping cycle, the pump pressure could straighten out the kink or force out the blockage. This rapid surge of material could cause the lines to **whip** or **move** in a manner that could cause injury to personnel.

7. It is important that once the slurry procedure is completed, and concrete is flowing through the hose, **DO NOT** stop the pour until all the slurry is pumped out and the concrete has reached the end of the hose. The only time to stop the pump during the priming procedure is if a blockage occurs.
8. If it is necessary to replace or add a section of delivery system, after the initial lubrication procedure, wet the inside area of the hose, pipe or elbow with 5 gallons of water per 25 foot length, before adding it to the system.

WARNING - TRANSPORTING PUMP

It will be necessary at times to move your pump from one job site location to another. Before moving the pump, make sure to pump the remaining concrete out of the hopper. Moving the pump with a **full hopper** of concrete can cause **severe damage** or breakage of the axle and axle springs, excess strain and pressure on the hub and bearing assembly.

When pumping long distance or pumping stiff mixes, you can expect a drop in volume compared to shorter lines and wetter mixes due to the change in valve efficiency or cavitation.

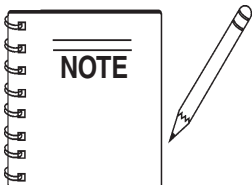

Leaking manifold seals or hose coupling gaskets which leak water can cause separation and subsequent jamming at that point.

REMIXTURES

Remixtures that are designed into the concrete mix by the redi-mix company or an architectural engineering company. This section lists common admixtures and a brief explanation of their functions:

- A. **Pozzolith 300** – or the equivalent acts as a water retarder and a lubricant. On a lean mix, long pushes, stiff mixes, and vertical pushes, Pozzolith 300R helps pumpability.
- B. **MBVR** – air entraining, acts as a lubricant.
- C. **Calcium Chloride** – commonly referred to as C.C., is used as an accelerator. When pumping a load with calcium chloride, it is recommended that you wash out if the waiting time between delivery trucks becomes too long.
- D. **Super Plasticizers** – acts as an accelerator. The concrete will look very wet after the super plasticizer is added, but will begin to set up very fast. Wash out immediately if you do not have a truck waiting. Super plasticizers are used mainly on commercial jobs.
- E. **Red Label** – acts as a water retarder and an accelerator. Red label will be used mainly on commercial jobs.
- F. **Fly Ash** – is used to help increase the strength of the concrete and decrease the cement content per yard. This is one of the most common admixtures used.

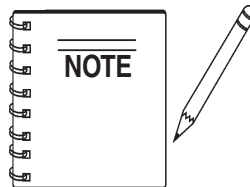

All admixtures will be shown on the redi-mix concrete ticket. Before starting the pumping job, ask the driver of the redi-mix truck to see the concrete ticket and note the admixtures that exist and take the proper action.

LS-60TD PUMP — OPERATING PROCEDURES

DOWN-HILL PUMPING

Down-hill pumping can be a difficult procedure on some jobs. The slurry procedure would be the same as explained **Priming The Pump With Slurry Mixture** section of this manual. It is suggested that a sponge approximately 2" x 4" x 6" in size be placed in the hose before the start of pumping.

Wet the sponge before placing it in the hose to keep the slurry from running too far ahead of the concrete, which will reduce the possibility of separation. When the pump is stopped, the material can flow slowly down, due to gravity, and cause the hose to collapse.

When pumping is resumed, you can expect blockage at the point of hose collapse. To prevent this from happening, the hose can be "kinked off" at the discharge end when the pump is stopped to prevent the gravity flow of the material in the hose.

The use of stiffer mixes when pumping down-hill will decrease gravity flow of the material in the hose and will assure a smoother operation between the cam roller bearing and cam plate. As with any job, make sure that the hose and the couplings are in good workable shape.

VERTICAL PUMPING

When pumping vertically up the side of a building, above 40 feet, we would recommend the installation of **steel pipe** securely fastened at intervals as necessary to support the pipe. Ninety degree, long radius pipe sweeps should be installed at the top and bottom of the steel line.

Use a 25 ft. hose, or short section, off the pump; and for the balance of the horizontal distance to the vertical line, use steel pipe. This type of installation has been satisfactory on many jobs being pumped in excess of 100 feet high. Line pressures are always less using steel pipe as compared to hose.

When pumping vertically, using **all hose**, it is recommended not to go higher than 50 feet with hose. The hose should be tied off at intervals of 10 feet, if possible. Special attention should be given when tying the hose off at the top as the hose will have a tendency to stretch when filled with concrete. This will increase the possibility of a blockage at the point where the hose is tied off. To avoid this, a long radius of 90° elbow is recommended. The suggested place to tie off is on the hose, under the clamp.

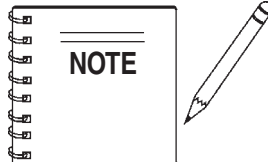

It is strongly recommended that **steel pipe** be used on all vertical pumping for safety and convenience.

HOSE PULSATION

A slight pulsation of the hose will always be noticeable near the pump. Excessive pulsation of the hose near the pump is normally due to higher than average line pressures caused by stiff, harsh mixes, or extremely long pumping distances.

The use of 2 - 1/2" I.D. hose in these extreme cases reduces line pressures or the addition of slight amounts of water to the mix, if permissible, will permit easier pumping. The use of certain pumping admixtures may help.

If excessive pulsation exists in the hose, it is advisable to use burlap or some means of wear protection under the hose at points where the hose may wear through the outer cover; e.g. over forms, steel or sharp curbs.

SNAP-JOINT COUPLINGS

When using Snap-Joint couplings with gaskets to join hose, see that they are washed clean after each job. Keeping the hose ends clean (heavy duty) is very important for the best job setup. A thin coat of grease on the rubber gasket or dipping both coupling and gasket in water before coupling the hose will make for easier installation.

NEW PUMPS

All new pumps are "water pressure tested" at the factory. This procedure permits a thorough inspection of entire drive system and valving under simulated full load conditions. The pump owner can do the same by making an adapter to couple to the end of the discharge cone: e.g., the use of a standard 2" pipe cap with a 3/8" drilled hole in the center, screwed on to the end of hinged cone or reducer at the pump.

Fill the hopper with water after making sure that all sand and rock have been removed from manifold. Operate pump at full throttle and the 3/8" diameter hole restriction will create sufficient back pressure to make thorough inspection of all moving parts.

LS-60TD PUMP — OPERATING PROCEDURES

THE EFFECTS OF HEAT AND EXCESSIVE TIME ON CONCRETE:

Hot concrete, commonly referred to as a hot load, is concrete that has been in the redi-mix truck in excess of 2 to 3 hours. On a hot day, this amount of time is even less.

A brief explanation of why heat and time affect concrete:

Concrete starts setting by drying up through a chemical reaction. The catalyst to this reaction is heat. When pumping a hot load, it is important to remember that when you have to stop pumping for any reason, add water to the concrete in the hopper and hand mix and move concrete in the hose every 5 minutes. If the shut down time becomes too long, wash out **immediately**.

If it is necessary to wait 1/2 hour or more for another load of concrete, to prevent setting of the mix in the system, it is advisable to consider the following factors (**A through D**) affecting the concrete :

- A. How old is the concrete?
- B. Is there an accelerator, calcium chloride, red label, etc., in the concrete?
- C. The temperature of the day, 80, 90, degrees?
- D. How much system you have out and how stiff was the mix you were pumping?

PREVENTING MIX SET-UP AFTER PUMP SHUTDOWN

When the pump is stopped for any reason during a pour; e.g., moving hose, waiting for redi-mix truck, the following suggestions are offered:

1. Leave the hopper full of concrete at the time of shutdown. It is important not to let the **redi-mix** driver wash too much water into the hopper, as this could cause separation of the concrete in the hopper.
2. If the **shutdown** period exceeds 2 to 3 minutes, turn off the engine so the vibration does not separate the mix in the hopper which can cause a blockage in the manifold when the pump is started.

3. If it is necessary to wait 10 minutes or more for another load of concrete, it is wise to start the pump and pump 6 or 8 strokes every 5 minutes to prevent setting of the mix in the system. If waiting time is excessive, it would be wise to wash out the pump and hoses and start over when the new truck arrives.
4. When pumping stiff mixes and there is waiting time between redi-mix trucks, it is advisable to add some water to the last hopper of material and “hand mix” to ensure an easier start with the following load.
5. When the pumping job requires a stiffer mix, the following method is suggested for starting: Take a water hose with a nozzle on it and apply water with a fine spray to the concrete as it comes down the redi-mix chute into the pump hopper after the slurry procedure is completed and you are ready to start pumping.

Using this procedure will make it easier to pump through the clean hose. Note: Once the concrete has reached the end of the hose, do not apply any more water in this manner as this procedure is used for starting only.

6. Hose sizing is very important: We strongly recommend on harsh mixes, vertical pushes, stiff concrete, shotcrete, long pushes, that a 2 -1/2” line be used as far as possible. The advantages of using the 2 -1/2” line are improved pumpability, less pumping pressure and less wear on the pump.
7. Following the pump operation, proper wash out of all materials or “build-up” within the pump manifold and hoses will prevent problems when starting the next job.
8. A thorough inspection of the drive components and greasing of all bearings after each job will ensure adequate lubrication and service to the pump which is normally operating in wet, gritty conditions.

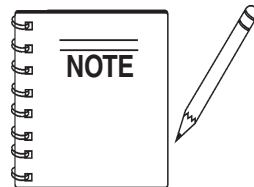

Over-greasing any **bearing** on your Mayco pump will not damage the bearing.

LS-60TD PUMP — OPERATING PROCEDURES

CLEARING THE SYSTEM AFTER MIX SET UP

If, for any reason, the mix should set up in the system, the following procedure is suggested:

1. Disconnect the hose from the pump and wash the pump out immediately.

WARNING - HOSE/LINE PRESSURE

When disconnecting hoses, use **EXTREME CAUTION!** The hose is under pressure!

2. Reconnect the hose and fill the hopper with water.
3. Reconnect the hose and fill the hopper with water. **DO NOT** try to push all the concrete out of all of the hose lines at one time.

For example: If you had 200 ft. of system out, you would disconnect each hose. Clean it out by pushing water through the first hose off the pump, then continue progressing through all the hoses, until all the system is clean.

4. If waiting time is excessive, it would be wise to wash out the pump and hoses and start over when the new truck arrives. This can be avoided by being observant to the pump and system, also taking into consideration the above actors (A through D) affecting the mix.

CLEARING CONCRETE BLOCKAGE

WARNING - BLOCKAGES

If you repeatedly pull the throttle all the way out and try to force your pump to push through **blockages** due to separation of material in the hose or manifold, you will soon have breakdowns and costly repairs which are not covered under warranty.

If a blockage occurs, find where it is and clear it before further pumping. **DO NOT** increase the engine speed to clear the blockage. Increasing the engine speed will only compound the problem.

If a blockage occurs in a hose, **walk the hose** until you find the point of trouble. The hose will be soft immediately past the blockage. To clear the blockage:

1. Disconnect the hose at the first coupling past the blockage.

WARNING - HOSE LINE PRESSURE

Use extreme care! The hose line is under **pressure** and can cause serious injury.

2. Elevate the hose at that point with the blockage area hanging down.
3. Using a hammer, you can pound the down-stream edge of the packed area until it is free to flow. Shake all of the sand and gravel out to the end of the hose.
4. Before reconnecting the hose, start the pump and run a small amount of concrete out to the end of the hose. This will assure that all of the separation is out of the hose.

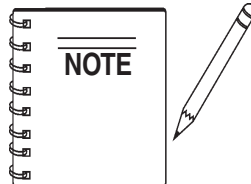

Damaged hoses with internal restrictions can cause blockages.

LS-60TD PUMP — OPERATING PROCEDURES

CLEARING SHUTTLE TUBE BLOCKAGE

The shuttle tube is plugged if volume at the discharge end of the hose stops and the hydraulic oil pressure gauge reads 3200 PSI or more.

To clear a plug in the shuttle tube, great care must be taken as a dangerous condition will exist from pressure build-up inside the shuttle tube. (With the shuttle valve, the concrete can be pumped in reverse.) Use the following procedures to clear the shuttle tubes.

WARNING - SHUTTLE TUBES

DO NOT open any of the delivery system joint clamps.

“REVERSE” PUMPING PROCEDURE

- A. Switch the pump into **REVERSE**. With pump speed at a medium-slow (approx. 12 strokes per min.) try to pull the “pack” back into the hopper with **5 or 6 reverse strokes**.
- B. Remix the concrete in the hopper.
- C. Switch the pump into **FORWARD**. If it is still plugged, repeat “Reversing” procedure three times.

If concrete still does not move, proceed to the Shuttle Tube Inspection Procedure.

WARNING - ACCUMULATOR PRESSURE

Make sure the accumulator pressure gauge reads **ZERO psi**. prior to performing any maintenance or inspection.

SHUTTLE TUBE INSPECTION PROCEDURE

- A. Stop the pump. Switch off the engine.
- B. The senior or most experienced operator must warn all others to stand at least **20 feet** away from the machine and turn their heads to face away from the pump.
- C. The operator will position themself beside the reducing elbow at the pump outlet. Wearing **safety glasses**, slip the end of a pry bar (24" length of reinforcing steel rod) under the latch of the hose clamp and flip it up.
- D. Carefully knock the end of the hose away from the reducer.

- E. Chip the concrete out of the reducer with the pry bar.
- F. Remove the reducer. From the discharge end, chip the concrete out of the shuttle tube with the pry-bar. If concrete cannot be loosened from the outlet of the shuttle tube, remove the clean-out plug on the bottom of the hopper to discharge the concrete.
- G. The **senior operator** may then remove the inspection cover plate from the shuttle tube by using a long extension wrench and the 24" pry bar.
- H. Chip the blockage out with the pry-bar.
- I. Flush the shuttle tube with water.
- J. Replace and seal the inspection cover plate on the shuttle tube.
- K. Before resuming operation of the pump, perform the “Reverse” Pumping Procedure to relieve pressure on the shuttle tubes.

LS-60TD PUMP — OPERATING PROCEDURES

HOPPER REMIXER CONTROL

The Hopper Remixer Control lever is located to the left of the Hydraulic Temperature gauge is (Figure 34).

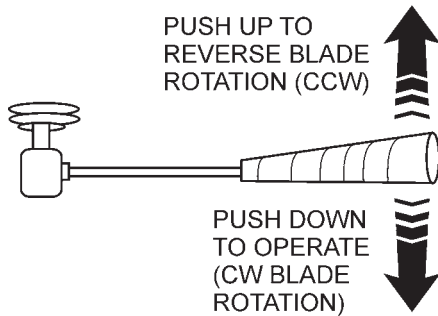

Figure 34. Hopper Remixer Control Lever

1. Push the Hopper Remixer Control lever **DOWNWARD** (Figure 35) and observe that the blades (Figure 37) inside the hopper are turning in a clockwise direction (forward).

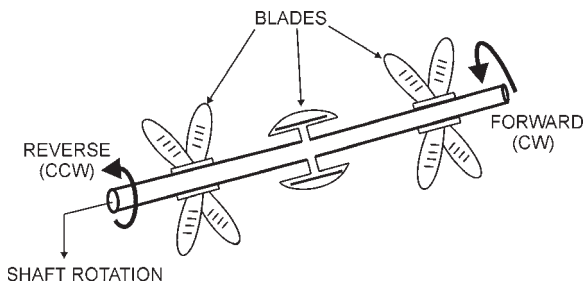

Figure 35. Hopper Remixer Blades (Rotation)

2. Push the Hopper Remixer Control lever **UPWARD** (Figure 34) and observe that the blades (Figure 35) inside the hopper are turning in a counter-clockwise direction (**REVERSE**).

RADIO REMOTE CONTROL (OPTIONAL)

The MAYCO LS-60TD Concrete Pump has a remote control feature that allows the pump to be remotely controlled. If desired, the pump can be operated via a receiver/transmitter method (Figure 36) or a hardwire method, which utilizes a 25-ft. extension cable.

The manual remote cord (Figure 37) should be installed under the main control box. Contact your MAYCO representative for further information.

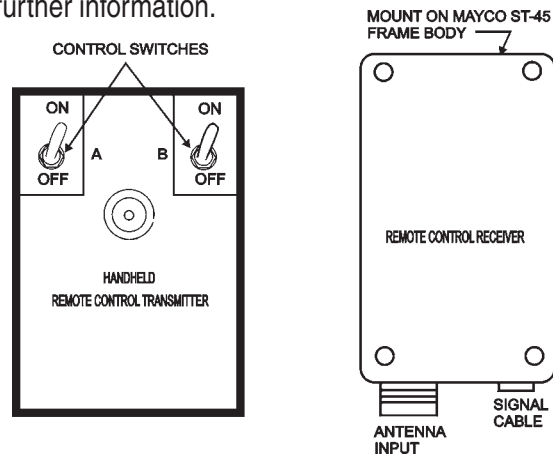

Figure 36. Handheld Receiver/Transmitter

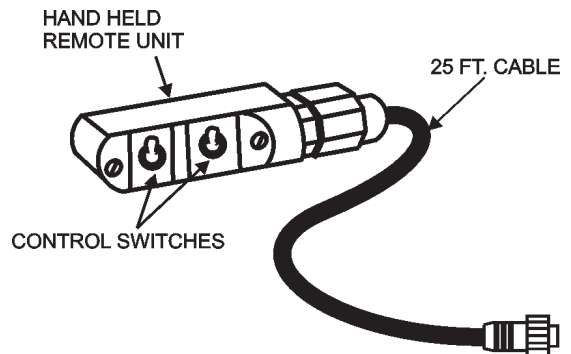

Figure 37. Handheld Remote Cable Unit

LS-60TD PUMP — TOWING SAFETY PRECAUTIONS

TOWING SAFETY PRECAUTIONS

CAUTION - LOCAL TOWING REGULATIONS

Check with your county or state safety towing regulations department before towing your **concrete pump**.

To reduce the possibility of an accident while transporting the pump on public roads, always make sure that the trailer and the towing vehicle are in good operating condition and both units are mechanically sound.

The following list of suggestions should be used when towing the pump:

- Make sure that the hitch and coupling of the towing vehicle are rated equal to, or greater than the trailer "gross vehicle weight rating" (GVWR).
- **ALWAYS** inspect the hitch and coupling for wear. **NEVER** tow the light tower's trailer with defective hitches, couplings, chains etc.
- **CHECK** the tire air pressure on both the towing vehicle and the trailer. Also check the tire tread wear on both vehicles.
- **ALWAYS** make sure the trailer section of the pump is equipped with a "**Safety Chain**".
- **ALWAYS** attach trailer's safety chain to frame of towing vehicle.
- **ALWAYS** make sure that the vehicle and trailer directional, backup, brake, and trailer lights are connected properly and are working properly.
- Remember in most cases the maximum speed unless otherwise posted for highway towing is 55 MPH, however before towing your pump, check your local state, and county vehicle towing requirements. Recommended off-road towing is not to exceed **15 MPH** or less depending on type of terrain.
- Place *chocked blocks* underneath wheel to prevent **rolling**, while parked.
- Depending on soil conditions and location it may be necessary to place *support blocks* underneath the trailer's bumper to prevent **tipping**, while parked.
- Inflate tires to correct pressure, inspect tires for cuts, and excessive wear. See Table 5 (Tire Wear Troubleshooting).

- Check wheel mounting lug nuts with a **torque wrench**. Torque wheel lug nuts as described in the "**Lug Nut Torque Requirements**", Table 6.
- Make sure brakes are synchronized and functioning properly.
- Check tightness of suspension hardware (nuts and bolts).
- Avoid sudden stops and starts. This can cause skidding, or jackknifing. Smooth, gradual starts and stops will improve gas mileage.
- Avoid sharp turns to prevent rolling.
- Retract wheel stand when transporting.
- **DO NOT** transport pump with fuel in the fuel tank.

CAUTION - DAMAGED TRAILER COUPLER

If the trailer coupler is deformed replace entire coupler. **NEVER** tow the pump with a defective trailer coupler. There exist the possibility of the trailer separating from the towing vehicle.

PUMP TRAILER VEHICLE CONNECTION

1. Check the vehicle hitch ball, and trailer coupler for signs of wear or damage. Replace any parts that are worn or damaged before towing.
2. Use only the 2-inch ball diameter with a towing capability of 6,000 lbs. (2,720 kg) as indicated on the trailer's coupler. Use of any other ball diameter will create an extremely dangerous condition which can result in separation of the coupler and ball or ball failure.
3. Be sure the coupler is secured to the hitch ball and the lock lever is down (locked).
4. Attach safety chains as shown in Figure 40. Remember to **cross** the safety chains.
5. After towing for about 50 miles recheck the entire towing system for tightness.

RECOMMENDED MAINTENANCE

1. Smear ball socket and clamp face with chassis grease. Periodically oil pivot points and wear surfaces of coupler with SAE 30 W motor oil.
2. When parking or storing the concrete pump, keep the coupler off the ground so dirt and other debris will not build up in the ball socket.

TOWING INFORMATION

! WARNING - LIFTING TRAILER TONGUE

Use jack stand to lift tongue. **DO NOT** lift by hand as back injury could result.

! CAUTION - TRAILER BALL CAPACITY

The ball capacity must be greater than or equal to the trailer GVWR. Do not use a worn hitch ball, it is unsafe and must be replaced. **USE 2" BALL ONLY**



Take care not to damage the actuator when backing up the towing vehicle for hook-up.

1. Position actuator ball socket above 2" ball.
2. Hold the release lever in the open position (Figure 38).
3. Lower the trailer tongue until the ball rests in the ball socket.
4. Close the release lever.

RELEASE LEVER
UNLOCK POSITION
(OPEN)

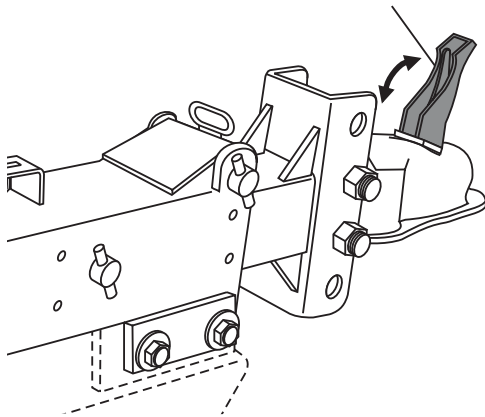
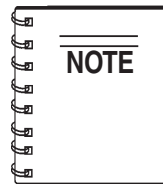

Figure 38. Trailer Hitch Release Lever

! CAUTION - TRAILER RELEASE LEVER

The release lever will close freely with finger pressure when the ball is properly inserted into ball socket. If the release lever does not close freely, do not tow the pump. **DO NOT** force the release handle into the closed position.

5. To make sure that the coupler is securely latched onto the ball, extend the trailer tongue jack to the ground and lift the truck and trailer combination 2" to 4". If the ball does not disengage, the coupler is securely attached.
6. Insert a padlock or bolt through the lock hole for added protection.
7. Connect the break-away cable solidly to the bumper or frame of the tow vehicle as near to the center as possible. The cable must hang clear of the trailer tongue and be long enough to permit short radius turns without pulling the breakaway cable forward.



Check the location of the breakaway cable periodically during each trip. The indicator should rest against the rear stop. Accidental application will cause the brakes to drag and heat up, causing a failure.

LS-60TD — TOWING INFORMATION

8. Test the brakes by pulling the emergency stop lever (Figure 39) forward until it locks into its second notch position. Attempt to rotate the wheels in a forward direction.

If any wheels rotate, the brakes must be adjusted. Return the emergency stop lever to its release position to adjust the wheel brakes. Repeat step 8 as needed until brakes prevent all wheel movement.

EMERGENCY BRAKE LEVER RELEASE POSITION

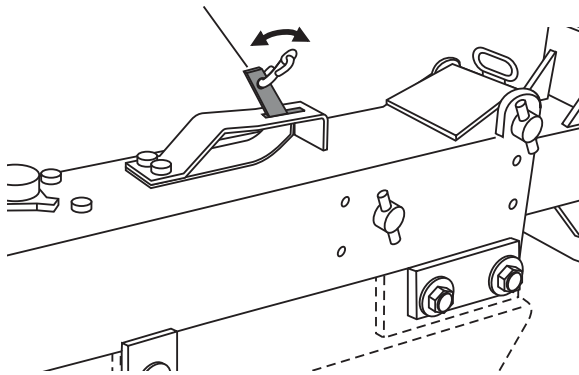

Figure 39. Trailer Emergency Brake Lever

9. Cross the safety chains under the tongue and securely attach them to the bumper or frame of the tow vehicle. Check with local and state laws for proper compliance.

! CAUTION - SAFETY CHAINS

Safety chains must **ALWAYS** be used.

10. Retract the jack fully. Remove and store the caster, if applicable.
11. Check for proper truck-trailer hook-up; the tow vehicle and trailer should be level with a positive tongue load. For further information, consult a dealer.

! CAUTION - SHARP TURNS WHILE TOWING

Avoid sharp turns. This could bend, create extreme stress or fracture either the actuator or trailer tongue.

LS-60TD PUMP — TRAILER HITCH CONNECTIONS

Figure 40 shown below illustrates the typical towing application that should be used when towing the pump.

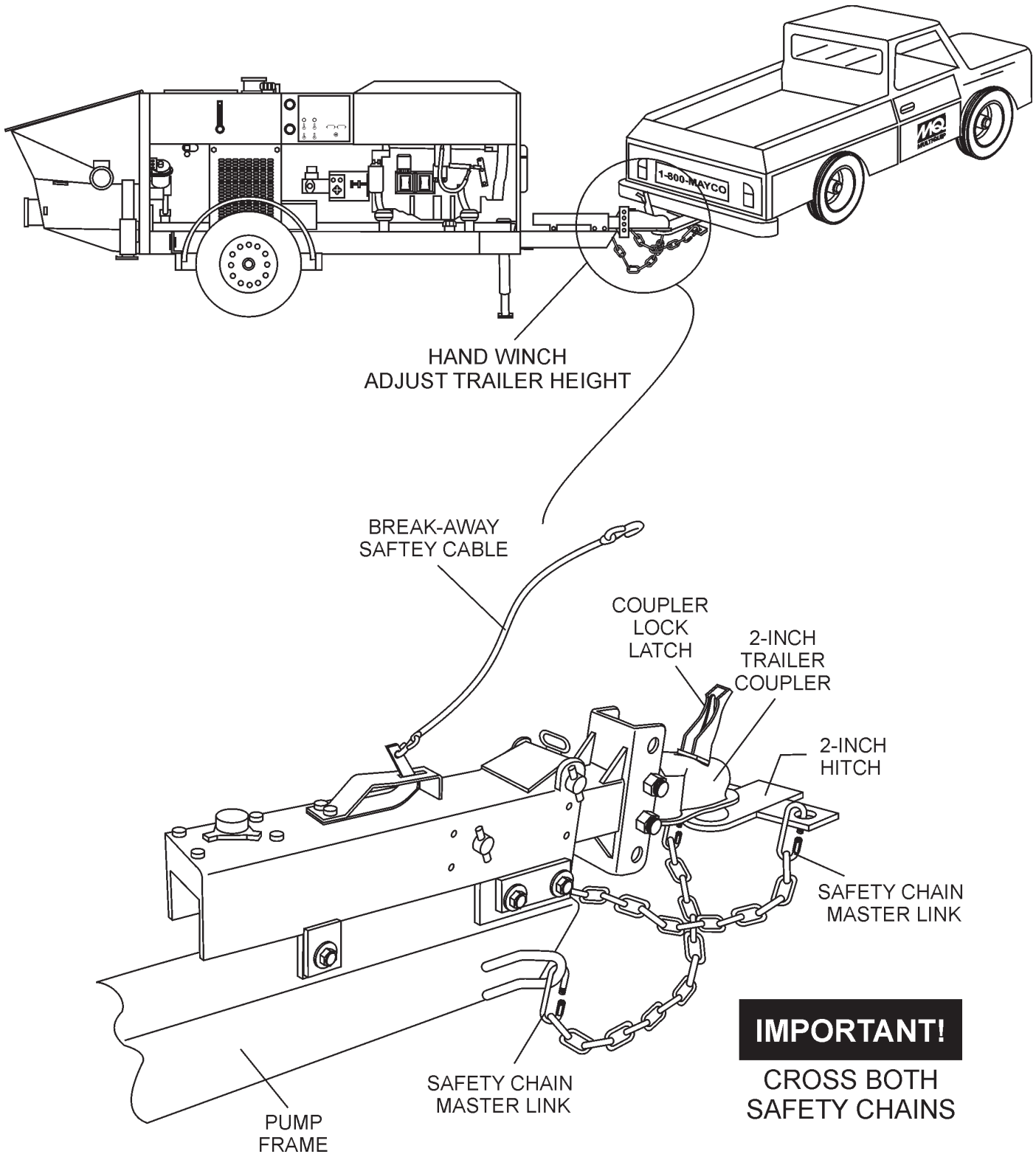

Figure 40. Trailer Hitch Connections

LS-60TD PUMP — MAINTENANCE (PUMP)

TABLE 5. MAINTENANCE CHECK SCHEDULE

	Daily	Hourly	Weekly	Monthly	6-Months	Operational Hours
Engine Oil	X			X		
Engine Air Filter				X		
Fuel Filter				X		
Hydraulic Oil Level	X					500 hrs.
Lubrication Box		X				
Replace Hydraulic Oil						
Clean Hydraulic Filters				X		2100 hrs.
Axle Crank	X					
Grease Shuttle Tube Zerk Points		X				2 hrs
Grease Remix Bearing	X					
Check System Pressure			X			40 hrs.
Check Hardware for Tightness			X			40 hrs.
Check Cutting Ware Ring			X			
Check Trailer Brakes Function	X					
Check Brake Lights	X					
Check Tire Conditions	X					
Inspect Safety Devices / Decals	X					
Check Wheel Bearings					X	
Check Battery				X		
Inspect Brake Lining					X	
Visually Check for Oil Leaks	X					

DANGER - AMPUTATION RISK

You will be required to put your hand in the concrete cylinders or near the shuttle tube. You are at **EXTREME RISK** of injury or **AMPUTATION** if the engine is running or if pressure is in the hydraulic system.

Prior to performing any maintenance on the pump, stop the engine by turning off the ignition switch and remove the starter key. Place a “**DO NOT OPERATE**” tag over the switch and disconnect the battery. The pressure reading on the accumulator pressure gauge **MUST** read **ZERO**. **ALWAYS** relieve the accumulator circuit to zero pressure prior to performing any maintenance on the pump.

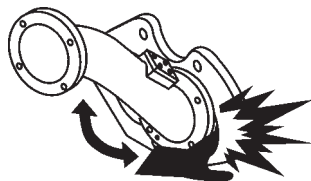

CLEANING THE PUMP AND DELIVERY SYSTEM

Cleaning the pump is a very important operation as it determines how the machine will pump the next time it is used.

At the end of every pour, or because of long delays during a pour, the pump and delivery system must be thoroughly cleaned by removing all concrete material.

1. Following the **Clearing Concrete Blockage** operating procedure, ensure that there is no blockage in the hose and line or in the shuttle tube (using the **Shuttle Tube Inspection Procedure**). If a blockage exists, clear it.
2. Pump concrete until the opening of the concrete cylinder intake in the hopper is visible.
3. Stop the pump.
4. Carefully disconnect the first hose joint at the shuttle tube discharge elbow.

LS-60TD PUMP — MAINTENANCE (PUMP)

5. Add water to the hopper. Pump and flush clean the entire hopper, shuttle tube and discharge elbow with water.
6. Scoop out 12 inches of concrete from the inboard end of the delivery hose. "Cork screw" a 6" x 6" x 8" sponge into the end of the first hose section. Reconnect the hose to the discharge elbow.
7. Fill hopper with water. Pump until sponge and clean water come out the discharge end of the hose and line system.
8. When the pump has been used to pump small aggregate concrete (pea rock, 1/2" minus) or mixes with high fines content (60% or more sand) there will be a tendency for hardened concrete to build up on the inside surface of the shuttle tube. Therefore, at the end of every such pour, after the pump and system have been cleaned and the engine shut off, remove the shuttle tube inspection plate (follow the **Shuttle Tube Inspection Procedure**) and remove all remaining concrete.
9. When the pump has been used to pump large aggregate concrete (3/4" to 1 1/2") follow the instructions in step 8 once per week.

WARNING - ACID CLEANING

NEVER use muriatic acid to clean the pump. Acid will dissolve the chrome finish on material cylinder bore and main hydraulic cylinder rods.

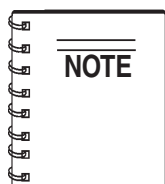

Use only a 2 1/2" diameter clean-out hook when back-pumping into redi-mix truck. Use a safety chain to secure the clean-out hook to some solid part of the mixer truck to prevent hook from jumping off of the drum. Run the pump at 6 strokes per minute maximum speed.

Deutz Model BF4L914 Diesel Engine

This pump is equipped with a Deutz BF4L914 turbo diesel engine. For information concerning the procedure in checking, removing, cleaning, etc. of the various engine parts or any other information on the engine not contained herein, refer to the engine manufacturer's instruction manual.

HYDRAULIC OIL SYSTEM MAINTENANCE

The Mayco pump is equipped with an in-tank return hydraulic filter with a 10 micron cleanable filter. The element has been designed to remove all particles large enough to cause wear and job break down. Under normal conditions, we recommend replacement every 6 month.

The most important factor to keep in mind is the effect of cold weather on the hydraulic oil. The viscosity (thickness) of the hydraulic oil will be much heavier.

ALWAYS run machine until oil temperature reaches a minimum of 50°F. before pumping. Damage to the main piston pump will occur if the machine is cycled too fast before the oil temperature reaches the minimum of 50°F. Cycle the machine at 6-8 strokes per minute at approximately 1/3 throttle.

In areas where the weather normally remains **under 50°F.**, use Shell Oil Tellus 46 (or the equivalent). The above steps must be followed or severe damage to the main axial piston pump can occur.

1. When changing the hydraulic oil or topping off the reservoir, use only the following type. (Reservoir capacity - 58 gal.)

Hydraulic oil: Shell Oil Tellus 68 or
Mobil DFE 26
Texaco Rand HDC

WARNING - HYDRAULIC OIL

DO NOT mix oil brands! This may impair quality.

2. Lubrication: Grease daily/Hour (Recommended after each Pour)
 - Main hydraulic cylinders - 2 Place
 - Axle crank - 1 Place
 - Suttle cylinders - 2 Place
 - "S" tube outlet flange - 3 Place

Grease Type: Lithium Based EP
Texaco Multitak 20
Lubriplate ED-2

LS-60TD PUMP — MAINTENANCE (PUMP)

BATTERY MAINTENANCE

CAUTION - BATTERY MAINTENANCE SAFETY

Wear **safety glasses** or **face mask**, **protective clothes**, and **rubber gloves** when working with battery.



Mishandling of the battery shortens the service life of the battery and adds to maintenance cost. When handling the battery do the following:

- Be careful not to let the battery electrolyte come in contact with your body or clothing.
- Always wear **eye protection** and **rubber gloves**, since the battery contains sulfuric acid which burns skin and eats through clothing.
- Always check the battery terminals periodically to ensure that they are in good condition.
- Use wire brush or sand paper to clean the battery terminals.
- Always check battery for cracks or any other damage. If white pattern appears inside the battery or paste has accumulated at the bottom, replace the battery.
- If the pump will not be in operation for a long period of time, store in cool dry place and check the battery charge level every month to maintain the performance of the battery.
- Check the battery regularly and make sure that each electrolyte level is to the bottom of the vent well (Figure 41). If necessary add only distilled water in a well-ventilated area.

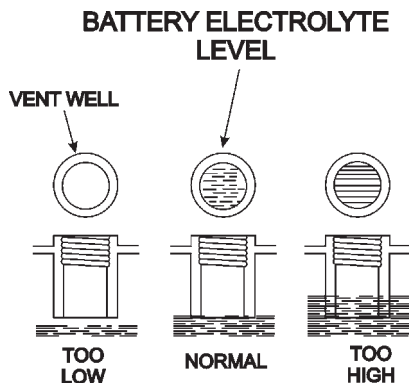
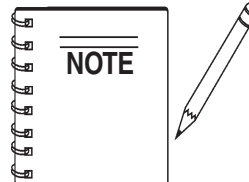

Figure 41. Battery Electrolyte Levels

BRAKE SYSTEM

The brake system should be periodically checked. Look for fluid leaks worn or cracked hoses. Check the reservoir for proper fluid levels. The Atwood surge brake should be checked for damage. Make sure that all links and pivots are kept lubricated. See Figure 16 for troubleshooting tips.

1. Keep all links and pivots lubricated to prevent rusting and ensure ease of operation. Using SAE 30 oil, lubricate inside the release handle and inside the actuator body. This can be reached from the underside of the actuator.



Lubricate the hitch ball with conventional automotive grease or a lubricant made for hitch balls.

2. Check for any leaks in the brake system. Periodic checks should be made on all hoses to guard against cuts and worn hoses which may cause failure (leaks, rupturing under pressure, and collapsing). Replace defective hoses.

CAUTION - MASTER BRAKE CYLINDER

DO NOT fill the master cylinder reservoir with used brake fluid. **DO NOT** fill the reservoir beyond ½" from top. **DO NOT** overfill; brake fluid will damage paint.

3. Check the brake fluid level in the master cylinder reservoir. Keep it filled to within ½" from the top of the reservoir.
4. At the beginning of each year, inspect the brakes for excessive wear, replace the linings if necessary.

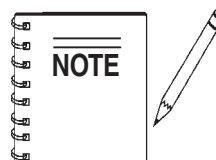

Wheel bearings and seals should be inspected and packed at this time.

LS-60TD PUMP — MAINTENANCE (PUMP)

CYLINDER LUBRICATION BOX

! WARNING - FREEZING CONDITIONS

When using the pump during freezing conditions, completely drain the water box and cover the hopper after pumping. Frozen liquid will restrict the piston travel and cause **severe damage** to the pump.

! CAUTION - SAFETY GUIDELINES

Before checking lubrication level, stop the engine and remove the engine starter key.

1. The lubrication level should be checked everyday prior to pumping and maintained at a height of 5 inches or about ½ the concrete cylinder height. We recommend a using a soluble type oil (water & oil mixture)
2. As the rubber piston cups naturally wear, fine cement particles will accumulate in the box. Once the concrete paste reaches a height of about ½ inch from the bottom of the box, drain and clean the lubrication box.

CLEANING THE LUBRICATION BOX

1. Remove the top cover and the drain plug (Figure 47) located at the bottom of the box and fully drain the inside of the box.
2. Once the box is drained, start the engine and stroke the cylinder (**keep hands out of box**) ten to fifteen times.
3. While stroking, spray water inside of the box to thoroughly clean out all contamination (Figure 42).
4. When the box is clean replace drain plug, add new lubrication and install the top cover.

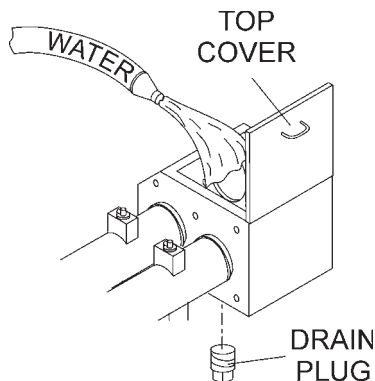
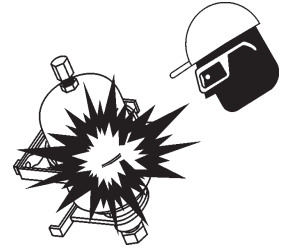

Figure 42. Cleaning the Lubrication Box

ACCUMULATOR CIRCUIT

! DANGER - ACCUMULATOR CHARGING

Improper accumulator charging can result in an explosion causing serious injury or death! **NEVER** use oxygen or compressed air to charge the accumulator! Only qualified personal should perform this procedure. Use only **dry nitrogen** to charge the accumulator. Contact your Mayco service department or your local Hydac representative for proper charging procedure.



The accumulator circuit has two functions in the hydraulic system.

- The accumulator circuit furnishes the hydraulic pressure to cycle the shuttle tube.
- The accumulator circuit also furnishes the pilot pressure necessary to activate the hydraulic system.

The accumulator circuit is equipped with a bladder type accumulator (Figure 43) charged with **1100 PSI** of dry nitrogen. The accumulator stores one gallon of hydraulic oil, which is, under **1750 PSI** of pressure.

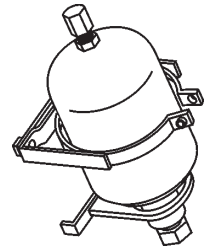

Figure 43. Accumulator

When the pump cycles, a part of the stored oil is released to the shuttle cylinder. This pressure release assures the shuttle tube has enough force to shear the cylinder of concrete passing from the concrete cylinder to the concrete delivery line during the cycle phase.

CHECKING ACCUMULATOR BLADDER PRESSURE

The normal accumulator charge pressure should be approximately **1100 PSI**. To check the accumulator pressure:

1. Start the engine and stroke the pump. The **accumulator pressure gauge** (Figure 29) should read **1750 PSI**.
2. To determine the **actual** accumulator PSI, stop the engine and observe the pressure gauge. As the PSI reading slowly decreases, it will reach a point where there will be a sudden drop in the PSI. The PSI reading should be taken just prior to this sudden drop. If you do not read 1100 PSI, the accumulator may require charging or bladder replacement.

LS-60TD PUMP — MAINTENANCE (PUMP)

CHANGING THE CONCRETE CYLINDER PISTON CUPS

The Rubber piston cups will occasionally require replacement depending on the following factors.

- The fluid level and cleanliness of the lubrication box.
- The size and type of aggregate.
- The type of concrete being pumped.

It is time to replace the cups when increasingly large particles of sand and cement pass into the lubrication box. Do not allow the cups to become so worn that they begin to pass lubrication into the material cylinders. If the liquid level of the lubrication box becomes low, the rubber cups will severely deform due to excessive heat. Whenever replacement is due, both cylinder cups should be replaced.

WARNING - AMPUTATION RISK

To prevent accidental cycling of any pump components, **ALWAYS** relieve the accumulator circuit to **ZERO** pressure prior to performing any maintenance on the pump.

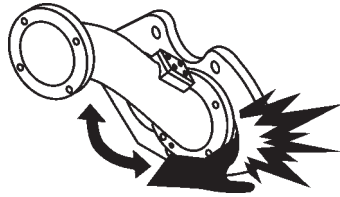

CYLINDER CUP REPLACEMENT PROCEDURE

1. Remove the two hydraulic hoses connected to the remix motor. Plug the ports with fittings(not provided) to prevent hydraulic hose leakage.
2. Remove the hopper discharge nipple and loosen sleeve seal. Inspect and replace if wear is excessive.
3. Remove the two tie rod nuts and the four eyebolt nuts securing the hopper to the pump frame.
4. Using an approved lifting device, remove the hopper using extreme care not to damage the hopper seal.
5. Start the engine and turn on the pressure test switch. Cycle pump in reverse until hydraulic system obtains maximum pressure, then turn pump and engine off.

Remove ignition key and disconnect battery. **Think safety!** Check the hydraulic gauges on panel and make sure accumulator pressure reads zero. One piston should be in the fully discharged position at the end of the concrete cylinder.

6. Remove the three 3/8 – 16 x 3” bolts from the piston. Remove the front faceplate.
7. Install two the 3/8’ 16x3” bolts back into the piston – do not tighten. Use the two bolts as leverage to remove the rubber piston cup and rear components.
8. Obtain two 3/8 16x7” full thread studs (these studs will be used to assist in assembly alignment) insert the two studs into the piston adapter. Coat the concrete cylinder with grease.
9. The new “O” ring must now be modified. Using a sharp knife cut four oil passage grooves into the ring. the grooves should be placed at a distance of 90° apart. The cut should be a v-shaped design, 0.059” deep and 0.157” wide at the top.
10. Install the “O” Ring around the oiler plate. Install the plate into the concrete cylinder utilizing the studs for alignment.

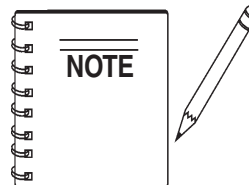

Felt ring must be saturated with 30 wt. oil prior to installation.

11. Install the felt holder over the oiler plate. Install felt ring into felt holder. Install the bronze ring.
12. Using silicon sealant place a small bead of sealant material on the front of the rubber piston cup and the rear of the face plate. Install over alignment studs and into concrete cylinders.
13. Insert one 3/8” 16x3” bolt into the open bolt hole, remove the alignment studs one at a time and install the remaining 3/8” 16x3” bolts.

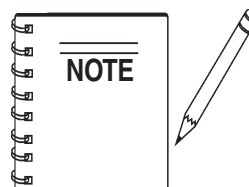

Before installing 3/8” bolt, coat the back of bolt heads with silicon sealant. Torque all three bolts equal at 55 ft. lbs. each.

LS-60TD PUMP — MAINTENANCE (PUMP)

CHANGING THE WEAR PLATE AND RING

Due to the swinging motion of the Nun-plate and the abrasive nature of concrete, it is normal for the cutting ring to wear on the side that shears through the concrete inside the hopper. If the wear ring and wear plate do not fully seat against each other the concrete slurry will pump into the hopper. This condition can be easily observed by the sudden change of the level of concrete inside the hopper during each stroke.

Wear Plate and Ring Replacement Procedure

1. Remove the two hydraulic hoses connected to the remix motor. Plug the ports with fittings(not provided) to prevent hydraulic hose leakage.
2. Remove the hopper discharge nipple and loosen sleeve seal. Inspect and replace if wear is excessive.
3. Remove the two tie rod nuts and the four eyebolt nuts securing the hopper to the pump frame.
4. Using an approved lifting device, remove the hopper using extreme care not to damage the hopper seal.
5. Remove the four 1/2" 1-1/4" bolts that hold the shuttle tube to the nun-plate and remove shuttle tube.

Using two small pry bars remove the rubber energizer ring, steel insert ring and wear ring.



The energizer ring and wear ring will normally have concrete contamination holding them in position. It will be required to chip some of the concrete loose to better expose the energizer ring.

6. Clean out all concrete build up in and around the nun-plate area with a wire brush.
7. Inspect the wear components for indications of wear. The wear plate has two wear surfaces. If it becomes necessary to replace, the plate can be reversed to the opposite side to expose a new flat surface. To replace or reverse the plate, remove the five allen head counter sink bolts. Then remove the two cylinder "O" rings and clean the entire back surface.

Wear Plate Installation

1. Install the two cylinder "O" rings.
2. Using silicon sealant, coat the circumference of the concrete cylinders, the back of the wear plate and around the five bolt holes. Next, install the wear plate and the five bolts. The bolts must all be equally snugged and tightened to 100 foot pounds each.

Wear Ring installation

1. Install the wear ring into the nun plate.
2. Install the steel insert ring inside of the rubber energizer ring.
3. Install the energizer ring assembly into the nun-plate.

After installing the above mentioned components the machine can be re-assembled by reversing steps 1 through 5 of the Wear Plate and Ring Replacement Procedure.

HEAT EXCHANGER COOLING FAN

This section is intended to make sure the fan is working properly. Under normal conditions the fan should be running any time the engine is turned on.



CAUTION - HYDRAULIC OIL TEMPERATURE

If the hydraulic oil temperature exceeds 170 degrees fahrenheit, **shut down the pump. DO NOT** continue to operate the pump. Failure to shut down the pump will result in severe damage to the pump.

LS-60TD PUMP — MAINTENANCE (PUMP)

WHEEL BEARINGS

After every 6 months of operation inspect the wheel bearings. Once a year, or when required, disassemble the wheel hubs remove the old grease and repack the bearings forcing grease between rollers, cone and cage with a good grade of high speed wheel bearing greases (never use grease heavier than 265 A.S.T.M. penetration "No. 2").

1. Fill the wheel hub with grease to the inside diameter of the outer races and also fill the hub grease cap.
2. Reassemble the hub and mount the wheel. Then tighten the adjusting nut, at the same time turn the wheel in both directions, until there is a slight bind to be sure all the bearing surfaces are in contact.
3. Back off the adjusting nut 1/6 to 1/4 turn or to the nearest locking hole or sufficiently to allow the wheel to rotate freely within limits of .001" to .010" end play. Lock the nut at this position.
4. Install the cotter pin and dust cap, and tighten all hardware.

EXTENDED STORAGE INSTRUCTIONS

The following preventative maintenance is recommended for extended periods of storage.

1. Check brake system for proper fluid level in master cylinder and bleed all lines.
2. Lubricate all links and pivots to prevent any rusting.
3. Remove wheel and drum assemblies and spray a good anti-corrosion compound (CRC formula 5-56) under rubber boot on forward end of brake wheel cylinder. Avoid spraying drum and brake lining.
4. Grease all bearings and reinstall wheel and drum assemblies.
5. Make sure breakaway cable is fully released.
6. After extended storage, refer to the Maintenance Steps listed above to insure that the trailer is ready for towing.

LS-60TD PUMP — MAINTENANCE (TRAILER)

TRAILER SAFETY PRECAUTIONS

⚠ CAUTION - TRAILER INSPECTION

ALWAYS make sure that the trailer is in good operating condition. Check the tires for proper inflation and wear. Also check the wheel lug nuts for proper tightness.

This section is intended to provide the user with trailer service and maintenance information. Remember periodic inspection of the trailer will ensure safe towing of the equipment and will prevent damage to the equipment and personal injury.

It is the purpose of this section to cover the major maintenance components of the trailer. The following trailer components will be discussed in this section:

- Tires
- Lug Nut Torquing
- Suspension
- Electrical

The following list defines the major trailer components:

1. **Frame Length** – This measurement is from the ball hitch to the rear bumper (reflector).
3. **Frame Width** – This measurement is from fender to fender.
4. **Jack Stand** – Trailer support device with maximum pound requirement from the tongue of the trailer.
5. **Coupler** – Type of hitch used on the trailer for towing. This unit employs a 2" ball.
6. **Tires Size** – Indicates the diameter of the tire in inches (10, 12, 13, 14, etc.), and the width in millimeters (175, 185, 205 etc.). The tire diameter must match the diameter of the tire rim. This unit employs 7.35" X 14" tires.
7. **Tires Ply** – The tire ply (layers) number is rated in letters; 2-ply, 4-ply, 6-ply, 8-ply, 10-ply etc. This unit employs 6-ply tires.

8. **Wheel Hub** – The wheel hub is connected to the trailer's axle.
9. **Tire Rim** – Tires are mounted on a tire rim. The tire rim must match the size of the tire.
10. **Lug Nuts** – Used to secure the wheel to the wheel hub. Always use a torque wrench to tighten down the lug nuts. See Table 7 and Figure 38 for lug nut tightening and sequence.
11. **Axle** – This trailer employs a torsion bar type suspension, which can support 6,000 lbs.
12. **Electrical** – Electrical connectors (looms) are provided with the trailer so that brake lights and turn signal lights can be connected to the towing vehicle. See Figure 40 for proper wiring connections.

⚠ WARNING - SAFETY GLASSES

ALWAYS wear safety glasses when removing or installing force fitted parts. Failure to comply may result in serious injury.

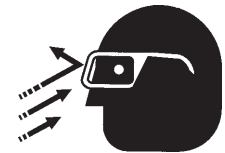

SUSPENSION

The torsion bar suspension and associated hardware (Figure 44) should be visually inspected every 6,000 miles for signs of excessive wear, elongation of bolt holes, and loosening of fasteners. Replace all damaged parts immediately.

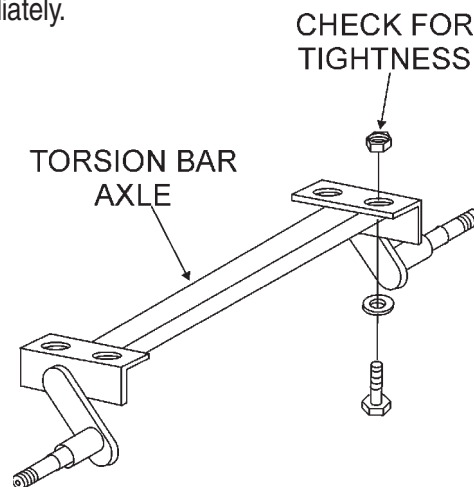

Figure 44. Torsion Bar Suspension Components

LS-60TD PUMP — MAINTENANCE (TRAILER)

TRAILER ACTUATOR

The following maintenance steps should be performed before towing the pump:

1. Frequently check actuator brake fluid levels. (Fluids must be approved, clean, and uncontaminated). Use DOT 3 or 4 brake fluid.
2. Make sure actuator mounting bolts and coupler bolts are secure.
3. Periodically check the brake system as described in the brakes owner's manual. Consult certified brake specialists to make necessary adjustments or repairs. Failure to do so could result in loss of braking capabilities.

Servicing the Actuator Emergency Lever

If the actuator emergency lever is applied, disengage using a screwdriver to lift upward on the front of the flat emergency lever spring while pulling the lever forward until it has been released.

Replace damaged parts as follows:

1. Remove the Master Cylinder and Push Rod Assembly. Be careful not to get dirt into the master cylinder. A new Master Cylinder Gasket should be used when re-installing.
2. Remove the Cable S-hook from the Emergency Lever, the Emergency Lever Guide, and the Flat Emergency Lever Spring, then pull the lever out of the actuator outer case through the cross-slot at the top of the case.
3. Install a new emergency lever through the cross-slot in the actuator casing. Attach a new emergency lever spring and emergency lever guide.
4. Install a new master cylinder gasket to the master cylinder. Put the push rod assembly and master cylinder back into the outer case of the actuator.
5. Set the S-hook onto the emergency brake cable and insert into the emergency lever. Squeeze the s-hook shut to secure it to the lever.
6. Add adequate brake fluid to the master cylinder and bleed the brake system.

TIRES/WHEELS/LUG NUTS

Tires and wheels are a very important and critical components of the trailer. When specifying or replacing the trailer wheels it is important the wheels, tires, and axle are properly matched.







! CAUTION - TRAILER WHEEL MAINTENANCE

DO NOT attempt to repair or modify a wheel. **DO NOT** install an inter-tube to correct a leak through the rim. If the rim is cracked, the air pressure in the inter-tube may cause pieces of the rim to explode (break-off) with great force and can cause serious eye or bodily injury.

TIRES WEAR/INFLATION

Tire inflation pressure is the most important factor in tire life. Pressure should be checked cold before operation. **DO NOT** bleed air from tires when they are hot. Check inflation pressure weekly during use to insure the maximum tire life and tread wear.

Table 6 (Tire Wear Troubleshooting) will help pinpoint the causes and solutions of tire wear problems.

TABLE 6. TIRE WEAR TROUBLESHOOTING			
WEAR PATTERN		CAUSE	SOLUTION
	Center Wear	Over Inflation	Adjust pressure to particular load per tire manufacturer.
	Edge Wear	Under Inflation	Adjust pressure to particular load per tire manufacturer.
	Side Wear	Loss of chamber or overloading.	Make sure load does not exceed axle rating. Align wheels.
	Toe Wear	Incorrect toe-in	Align wheels.
	Cupping	Out-of balance	Check bearing adjustment and balance tires.
	Flat Spots	Wheel lockup & tire skidding.	Avoid sudden stops when possible and adjust brakes.

LS-60TD PUMP — MAINTENANCE (TRAILER)

LUG NUT TORQUE REQUIREMENTS

It is extremely important to apply and maintain proper wheel mounting torque on the trailer. Be sure to use only the fasteners matched to the cone angle of the wheel. Proper procedure for attachment of the wheels is as follows:

1. Start all wheel lug nuts by hand.
2. Torque all lug nuts in sequence. See Figure 45. **DO NOT** torque the wheel lug nuts all the way down. Tighten each lug nut in 3 separate passes as defined by Table 7.

TABLE 7. LUG NUT TORQUE REQUIREMENTS

Wheel Size	First Pass FT-LBS	Second Pass FT-LBS	Third Pass FT-LBS
12"	20-25	35-40	50-65
13"	20-25	35-40	50-65
14"	20-25	50-60	90-120
15"	20-25	50-60	90-120
16"	20-25	50-60	90-120

3. After first road use, retorque all lug nuts in sequence. Check all wheel lug nuts periodically.

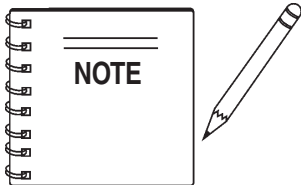

NEVER use an pneumatic air gun to tighten wheel lug nuts.

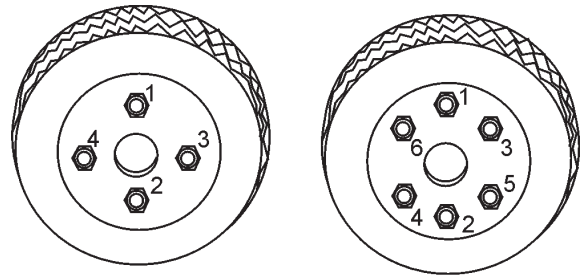

4-LUG NUTS

6-LUG NUTS

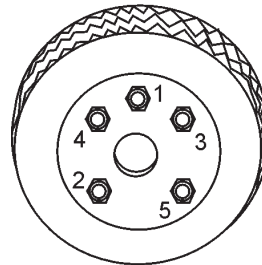

5-LUG NUTS

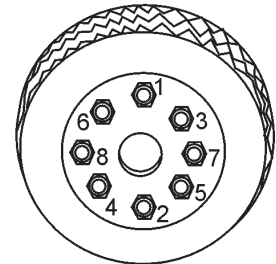

8-LUG NUTS

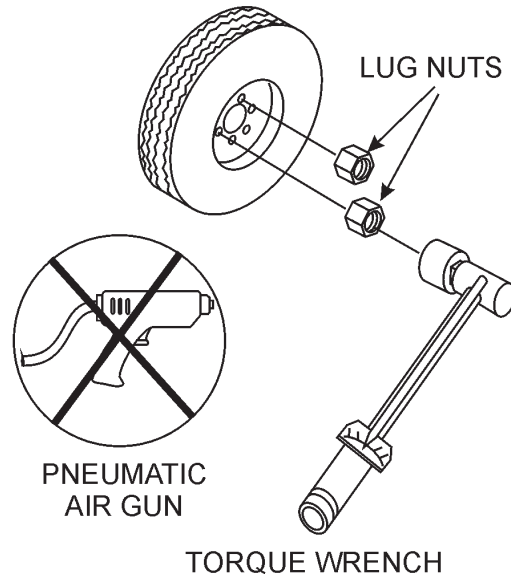

Figure 45. Wheel Lug Nuts Tightening Sequence

LS-60TD PUMP — WIRING DIAGRAM (TAIL LIGHTS)

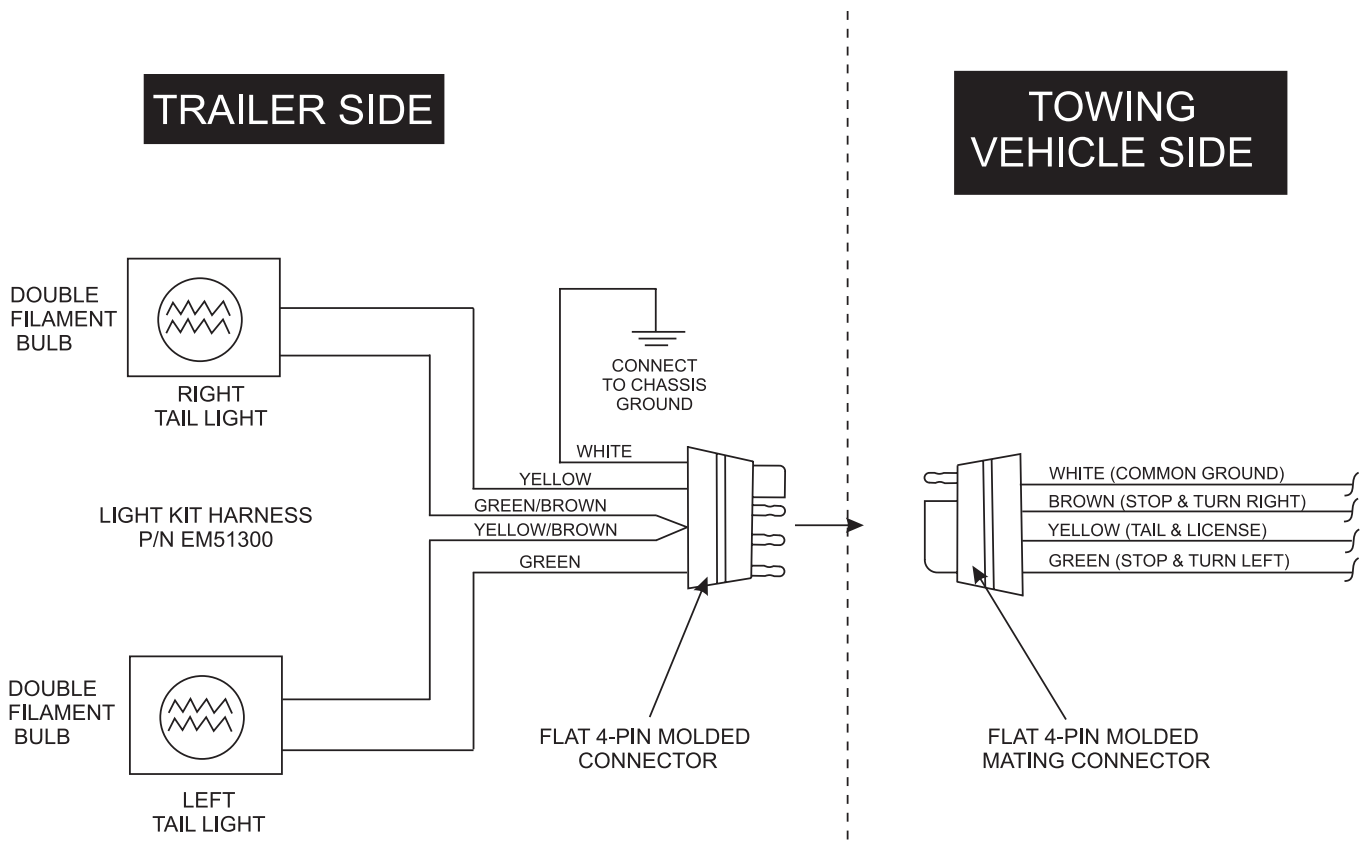

Figure 46. Trailer Tail Lights Wiring Diagram

LS-60TD PUMP — WIRING DIAGRAM (ELECTRICAL)

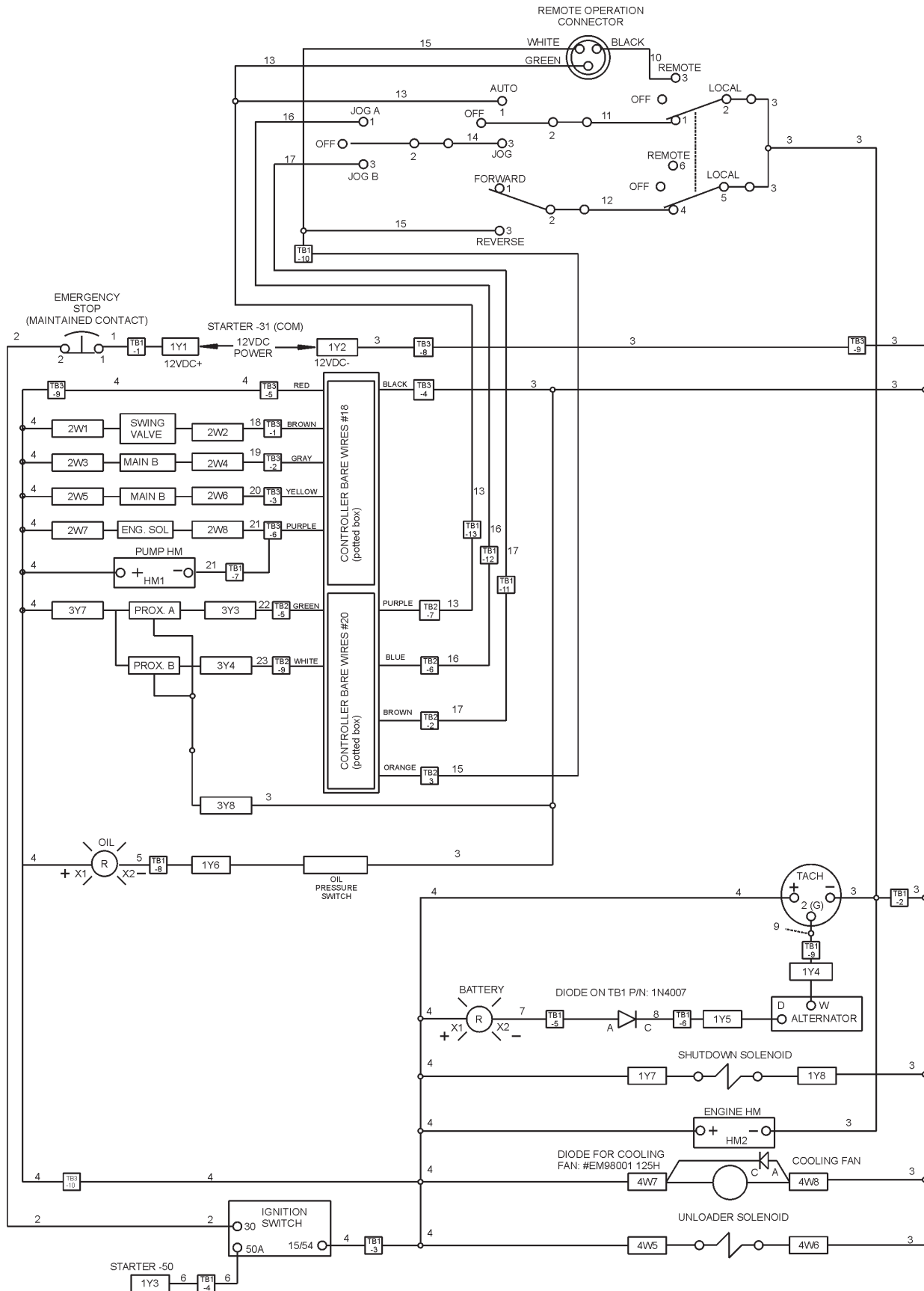

Figure 47. Electrical Wiring Diagram

LS-60TD PUMP — WIRING DIAGRAM (CONTROL PANEL)

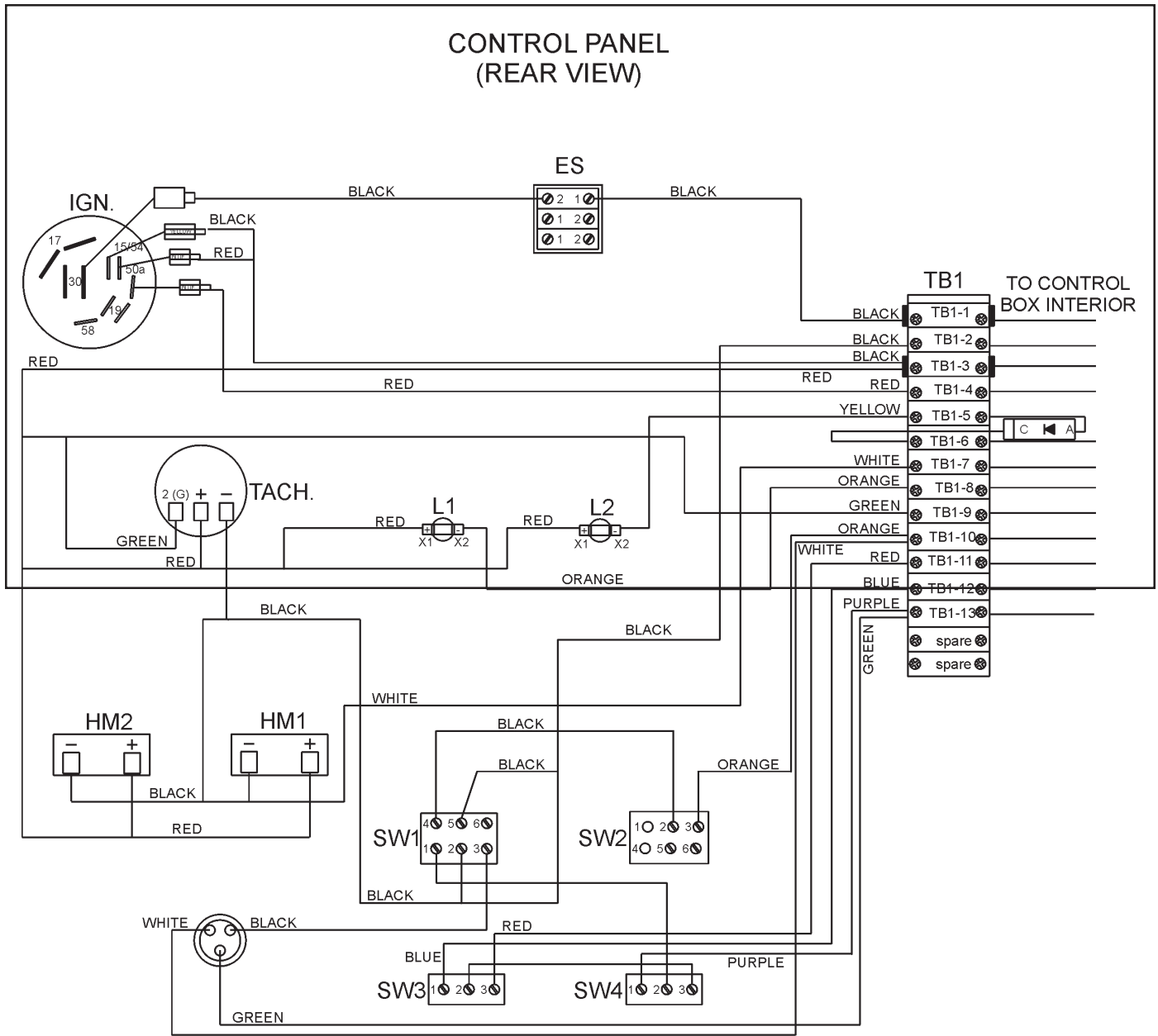

Figure 48. Control Panel Wiring Diagram

WIRING DIAGRAM LABELS	
ES	EMERGENCY STOP SWITCH
IGN	IGNITION SWITCH
TACH	TACHOMETER
L1	OIL LIGHT
L2	BATTERY LIGHT
SW1	PUMP CONTROL SWITCH
SW2	FLOW CONTROL SWITCH
SW3	AUTO/JOG SWITCH
SW4	JOB A/B SWITCH
HM1	ENGINE HOUR METER
HM2	PUMP HOUR METER
REM	REMOTE CONTROL PLUG
TB1	TERMINAL BLOCK 1

LS SERIES PUMP — WIRING DIAGRAM (TERMINAL BLOCKS)

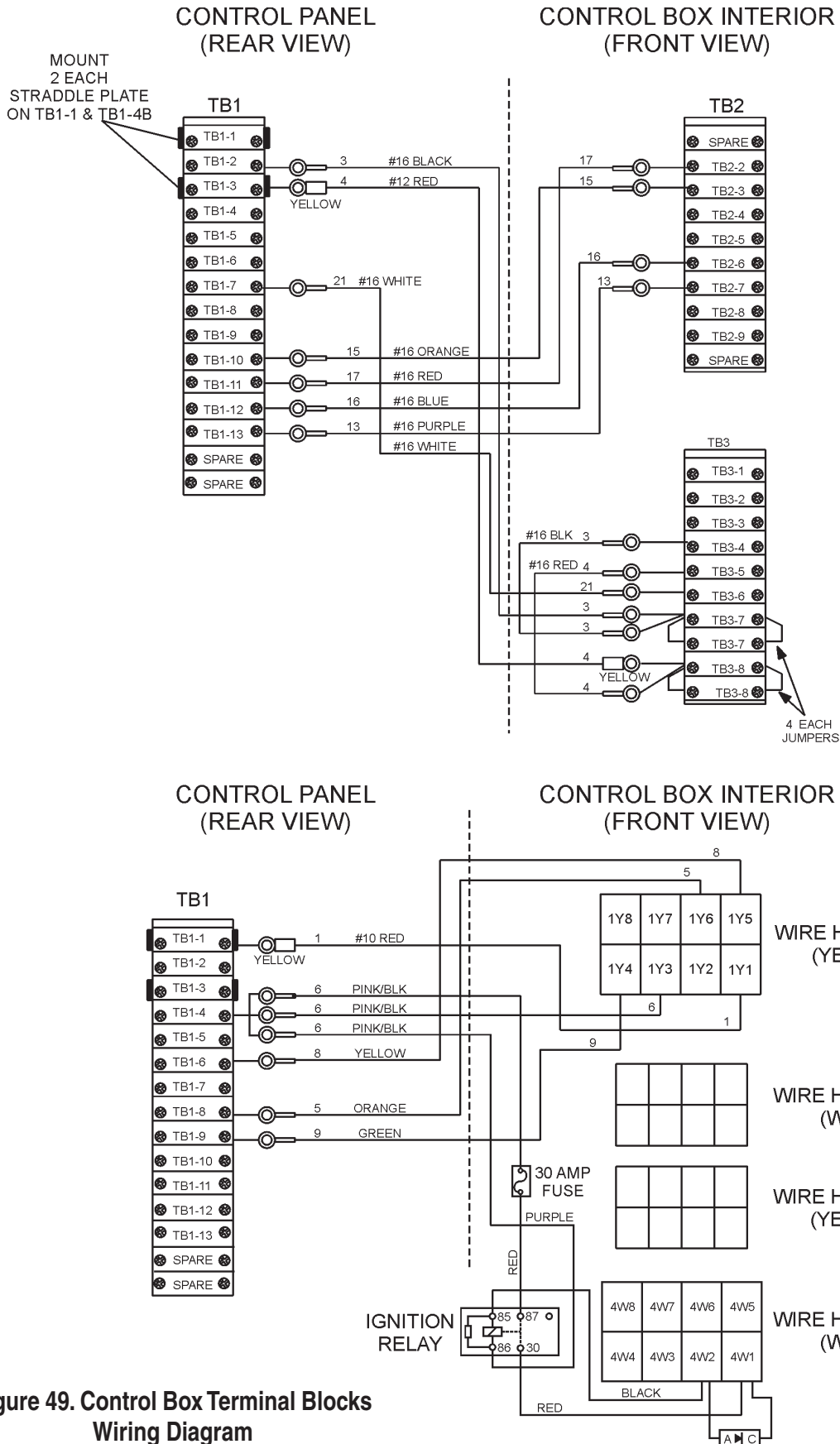

Figure 49. Control Box Terminal Blocks Wiring Diagram

LS SERIES PUMP — WIRING DIAGRAM (TERMINAL BLOCKS TO COMP.)

CONTROL BOX INTERIOR (FRONT VIEW)

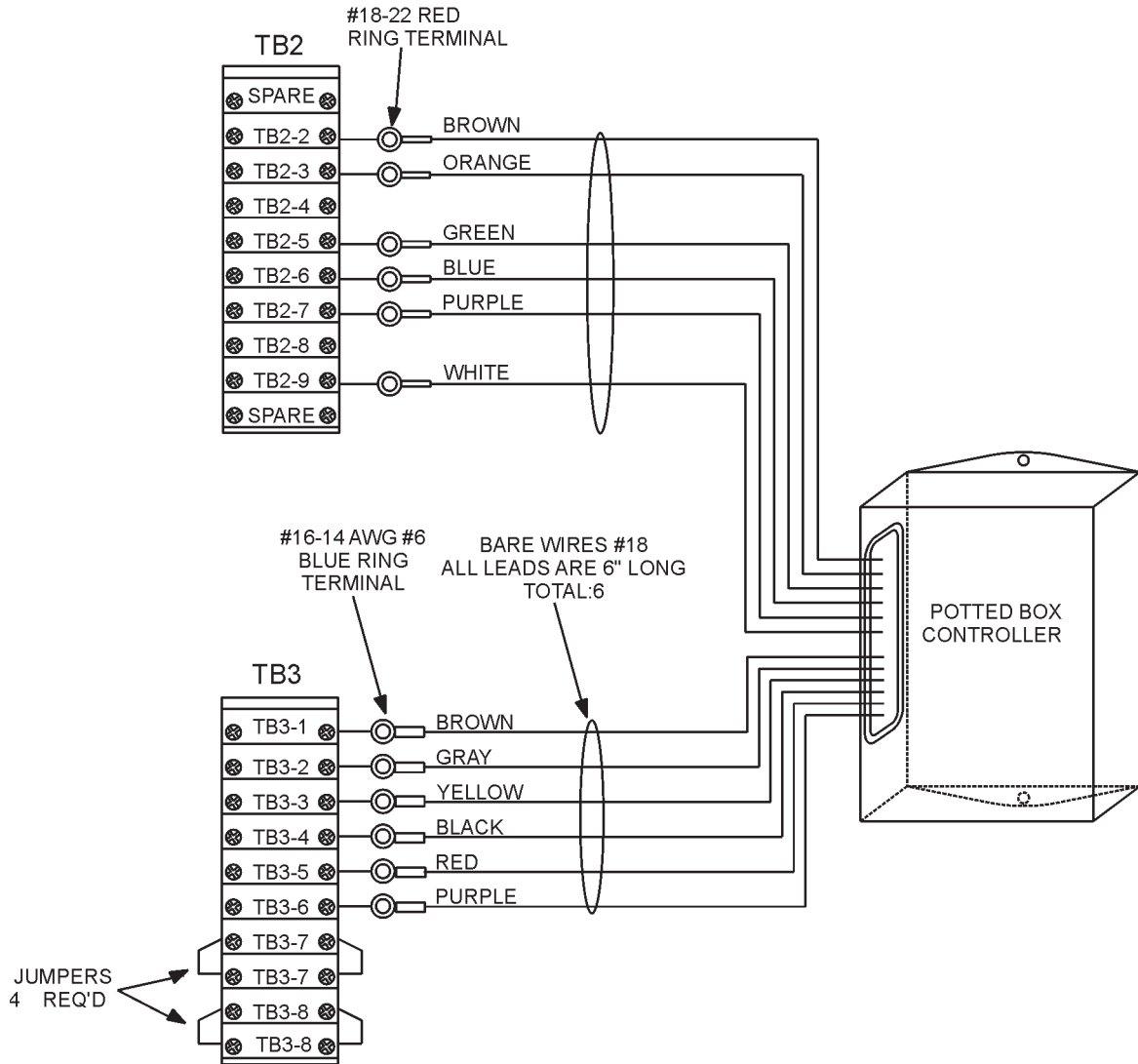
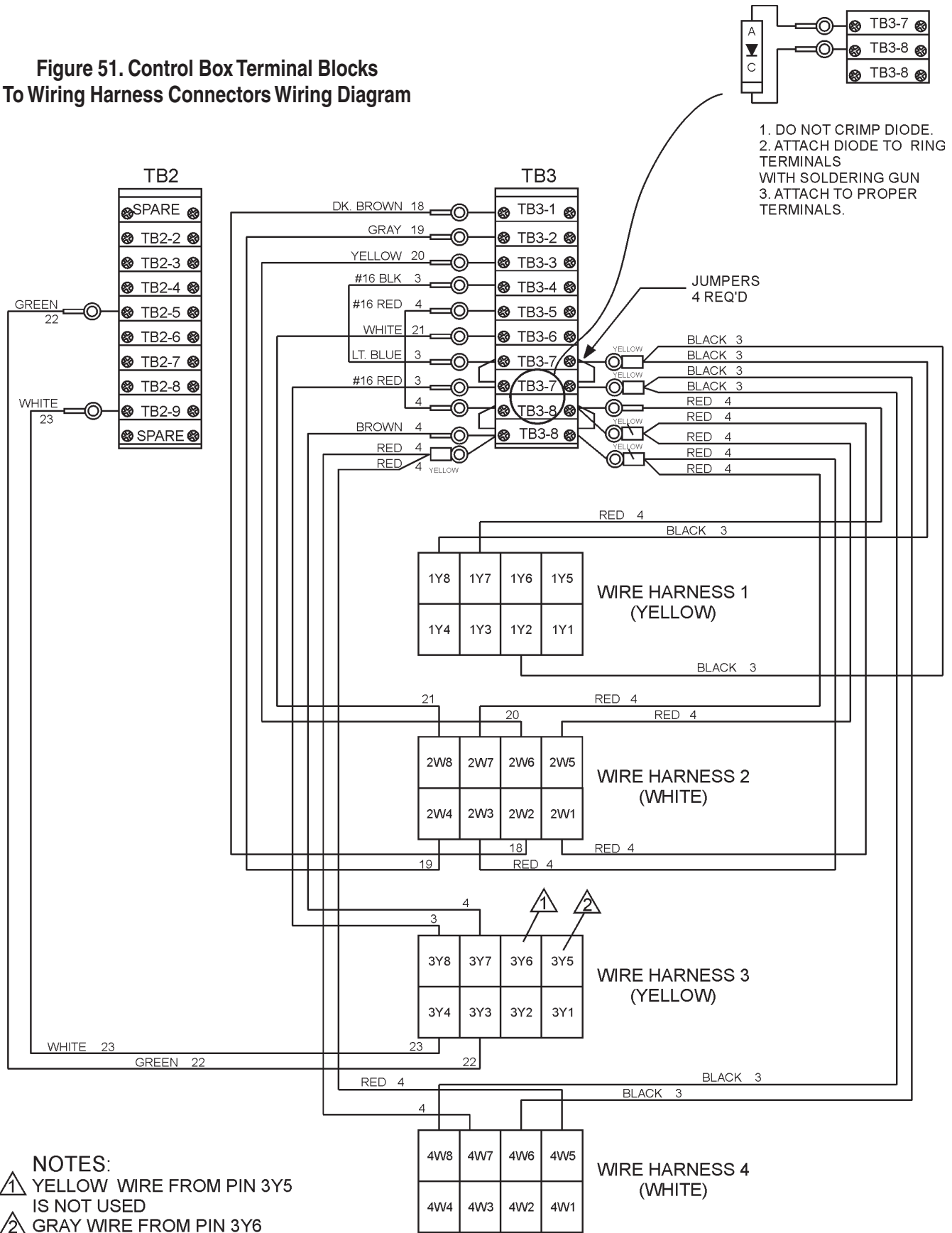

Figure 50. Terminal Blocks to Computer Wiring Diagram

LS SERIES PUMP — WIRING DIAGRAM (HARNESS CONNECTORS)

Figure 51. Control Box Terminal Blocks To Wiring Harness Connectors Wiring Diagram



- NOTES:**
- ① YELLOW WIRE FROM PIN 3Y5 IS NOT USED
 - ② GRAY WIRE FROM PIN 3Y6 IS NOT USED

LS SERIES PUMP — WIRING DIAGRAM (OPTIONAL HOPPER VIBRATOR)

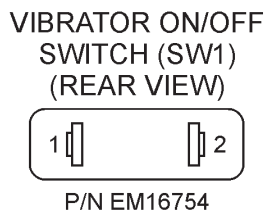
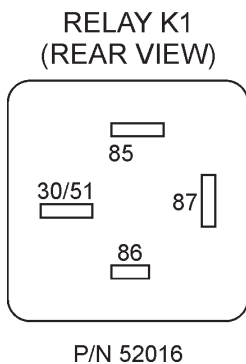
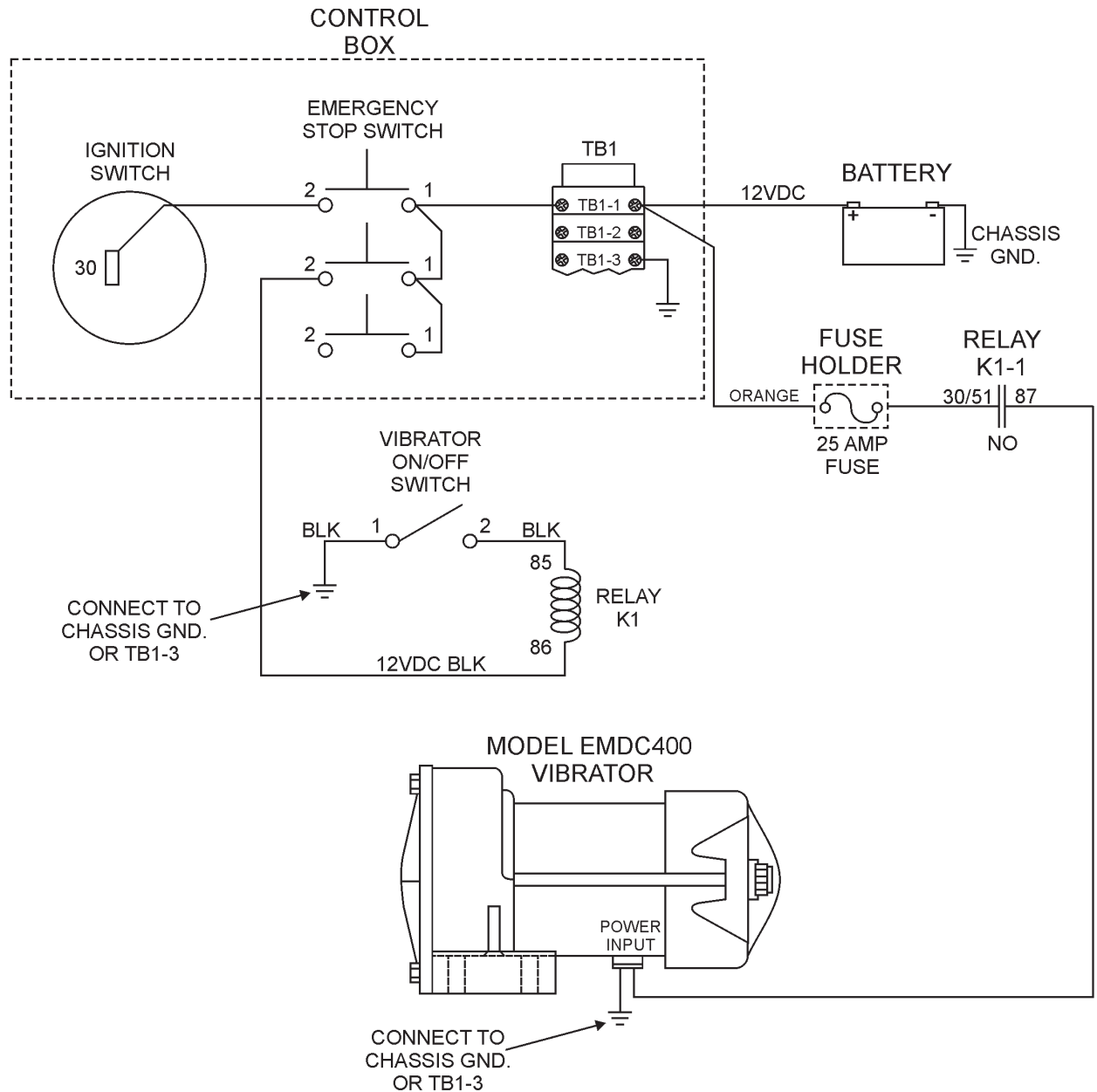

FUSE HOLDER
P/N Em987066

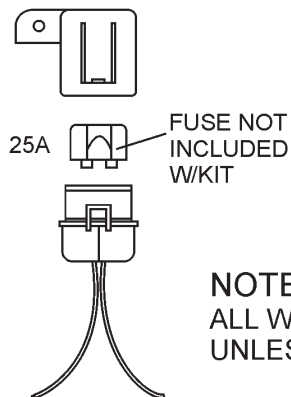

**Figure 52. Hopper Vibrator
Wiring Diagram (Optional)**

NOTE:
ALL WIRES ARE 10 AWG.
UNLESS OTHERWISE SPECIFIED

LS-60TD PUMP — HYDRAULIC SYSTEM DIAGRAM

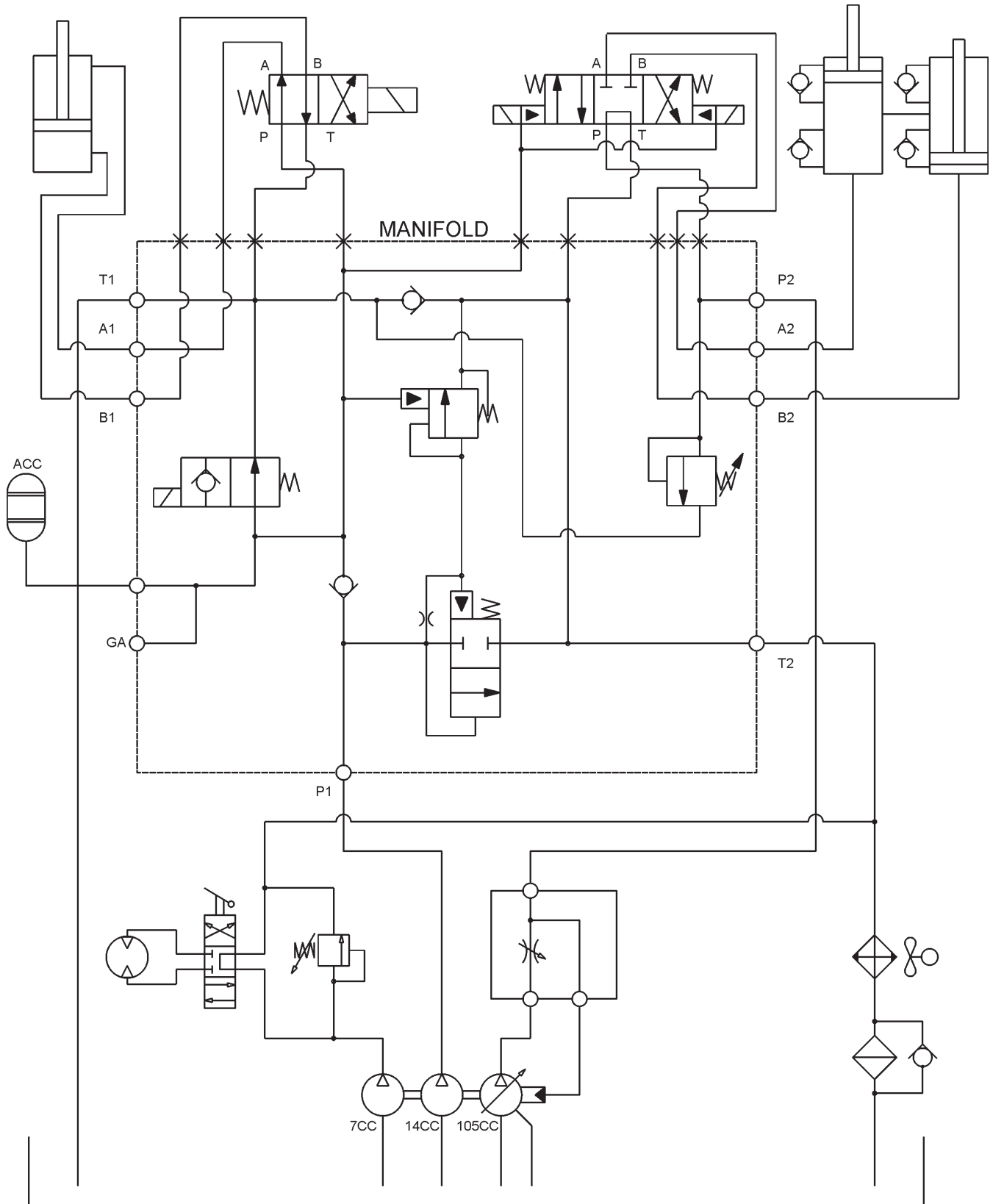
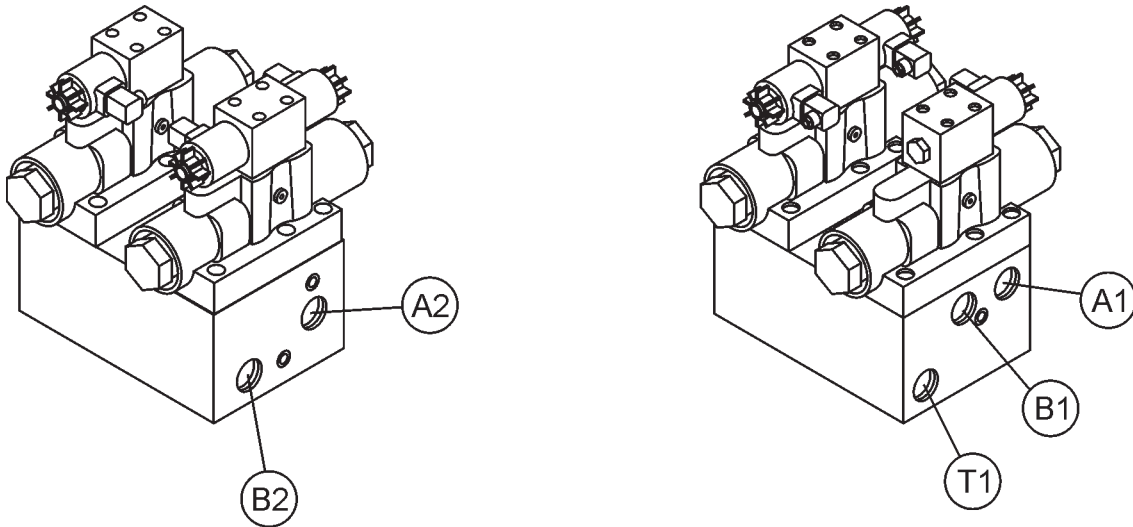

Figure 53. Hydraulic System Diagram

LS-60TD PUMP — MANIFOLD BLOCK PORTS



MANIFOLD BLOCK PORTS	
ACC	Connect to Accumulator Tank, Hose A
A1	Connect to Shuttle Cylinder, Hose T
A2	Connect to Hydraulic Cylinder, Hose I
B1	Connect to Shuttle Cylinder, Hose U
B2	Connect to Hydraulic Cylinder, Hose J
GA	Connect to Accumulator Gauge, Hose D
P1	Connect to Secondary Hyd. Pump, Hose E
P2	Connect to Flow Control Valve, Hose K
T1	Connect to Hydraulic Tank, Hose G
T2	Connect to Heat Exchanger, Hose L

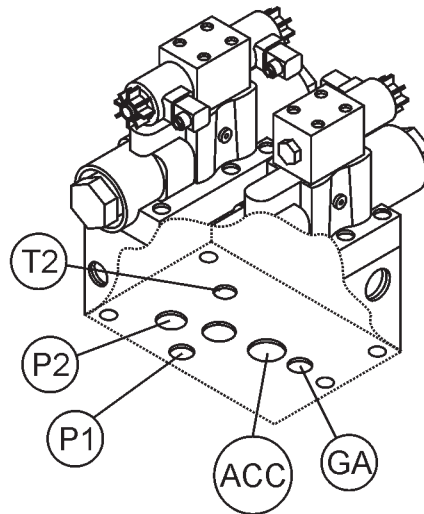

Figure 54. Manifold Block Ports

APPENDIX — CONCRETE MIX INFORMATION

The following information has been extracted from actual testing laboratory reports. The purpose of this printing is only to help create a better understanding of the importance of uniform gradation and proportioning of materials which affect pumpability of concrete mixes. These weights and proportions illustrate that when the sieve analysis is ideal, the sand/rock ratio can be adjusted (65% sand 35% rock) and pumpability should be excellent.

EXAMPLE #1 (A California Test Lab. Report)

JOB: Building Foundations (Water Project)

Sacks per cu./yd. 6.5 designed for 2,500 lbs. in 28 days
 Gallons per sack 7.1
 Washed Sand-#200 wash 1.3
 Organic matter-OK
 Specific gravity (SSD) Sand-2.58; Pea Gravel-2.60

Sieve analysis-percent passing

Material	1.5"	1"	3/4"	3/8"	#4	#8	#16	#30	#50	#100	#200
W.C. Sand				100	99.7	79.1	60.4	36.5	14.3	4.0	1.1
Pea Gravel				100	3.0						
% Comb.				100	66	51	39	23	9	3	1.0













DESIGN FOR ONE YARD OF CONCRETE (SATURATED & SURFACE DRY):

Absolute volume of aggregate in one cu. yard: 17.78 cu. ft.
 Specific gravity of aggregates in one cu. yard: 2.58
 Weight of aggregates in one cu. yard batch: 2850 lbs.

	<u>%</u>	<u>BATCH</u>	<u>SPEC. GRAVITY</u>	<u>ABS. VOL.</u>
W.C. Sand	65	1800	2.58	11.56
PEA GRAVEL	35	1000	2.60	6.22
WATER 46 gal.		1		
CEMENT 6.5 sk.		611		
TOTAL				27.00
ADMIXTURE:		None		
SLUMP		4"		
REMARKS		This mix designed for pumping		
NOTE:		Due to the availability of well-graded sand as shown in the above sieve analysis, this mix pumped very successfully.		

APPENDIX — CONCRETE MIX INFORMATION

A.S.T.M. STANDARD SPECIFICATION FOR GRADING AGGREGATE

SCREEN TYPE	U.S.	METRIC	PERCENTAGE PASSING BY WEIGHT
FINE AGGREGATE: Referred to as washed concrete sand.			
3/8" 	3/8"	9.50 mm	100%
#4 	4,760 microns	4.76 mm	95 to 100%
#8 	2,380 microns	2.38 mm	80 to 100%
#16 	1,190 microns	1.19 mm	50 to 85%
#30 	590 microns	.59 mm	50 to 85 %
#50 	297 microns	297 μm	10 to 30%
#100 	149 microns	149 μm	2 to 10%
3/8 (9.51 mm) PEA GRAVEL AGGREGATE: Referred to as #4 Rock or Gravel or 1/2" minus (12.7 mm) size			
1/2" 	1/2"	12.70 mm	100%
3/8" 	3/8"	9.51 mm	85 to 100%
#4 	4,760 microns	4.76 mm	10 to 30%
#8 	2,380 micron	2.38 mm	0 to 10%
#16 	1,190 microns	1.19 mm	0 to 5%

APPENDIX — SLUMP TEST PROCEDURE

1. To obtain a representative sample (concrete), take several samples at three or more regular intervals throughout the discharge of the mixer or truck. **DO NOT** take samples at the beginning or end of the discharge.
2. Dampen the inside of the cone and place it on a smooth, moist, nonabsorbent, level surface large enough to accommodate both the slumped concrete and the slump cone. Stand on the “foot pieces” throughout the test procedure to hold the cone firmly in place.
3. Fill the cone 1/3 full by volume (Figure 55-A) and rod 25 times with a 1/2" dia x 24" lg. bullet-pointed steel rod. (This is a specific requirement which will produce non-standard results unless followed exactly.) Distribute rodding evenly over the entire cross section of the sample.

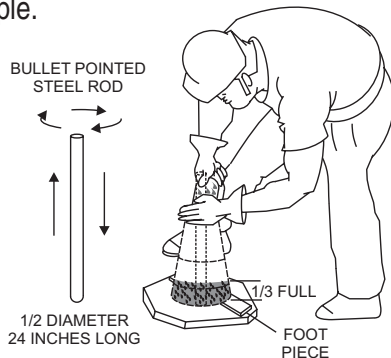

Figure 55-A. Slump Test (1/3 Full)

4. Fill cone another 1/3 (Figure 55-B) which will make the cone 2/3 full by volume. Rod this second layer 25 times with the rod penetrating into, but not through, the first layer. Distribute rodding evenly over the entire cross section of the layer.

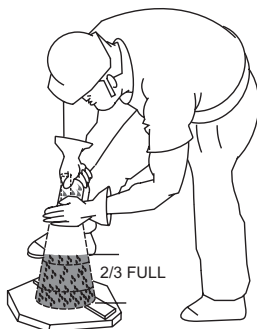

Figure 55-B. Slump Test (2/3 Full)

5. Fill cone to overflowing (Figure 55-C). Rod this layer 25 times with rod penetrating into but not through, the second layer. Distribute rodding evenly over the entire cross section of this layer.



Figure 55-C. Slump Test (Full-Overflow)

6. Remove the excess concrete (Figure 55-D) from the top of the cone, using the tamping rod as a screed.



Figure 55-D. Slump Test (Removing Excess Concrete)

7. Lift the cone vertically (Figure 55-E) with a slow even motion. **DO NOT** jar the concrete or tilt the cone during this process. (Invert the withdrawn cone, and place it next to, but not touching the slumped concrete.

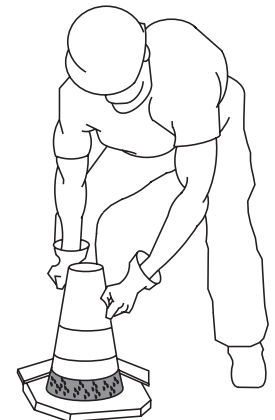

Figure 55-E. Slump Test (Cone Invert)

8. Lay a straight edge (Figure 55-F) across the top of the slumped cone. Measure the amount of slump in inches from the bottom of the straight edge to the top of the slumped concrete at a point over the original center of the base . The slump operation must be complete in a maximum elapsed time of 1-1/2 minutes. Discard the concrete. **DO NOT** use it in another tests.



Figure 55-F. Slump Test (Measurement)

APPENDIX — RECOMMENDED SHOTCRETE SYSTEM

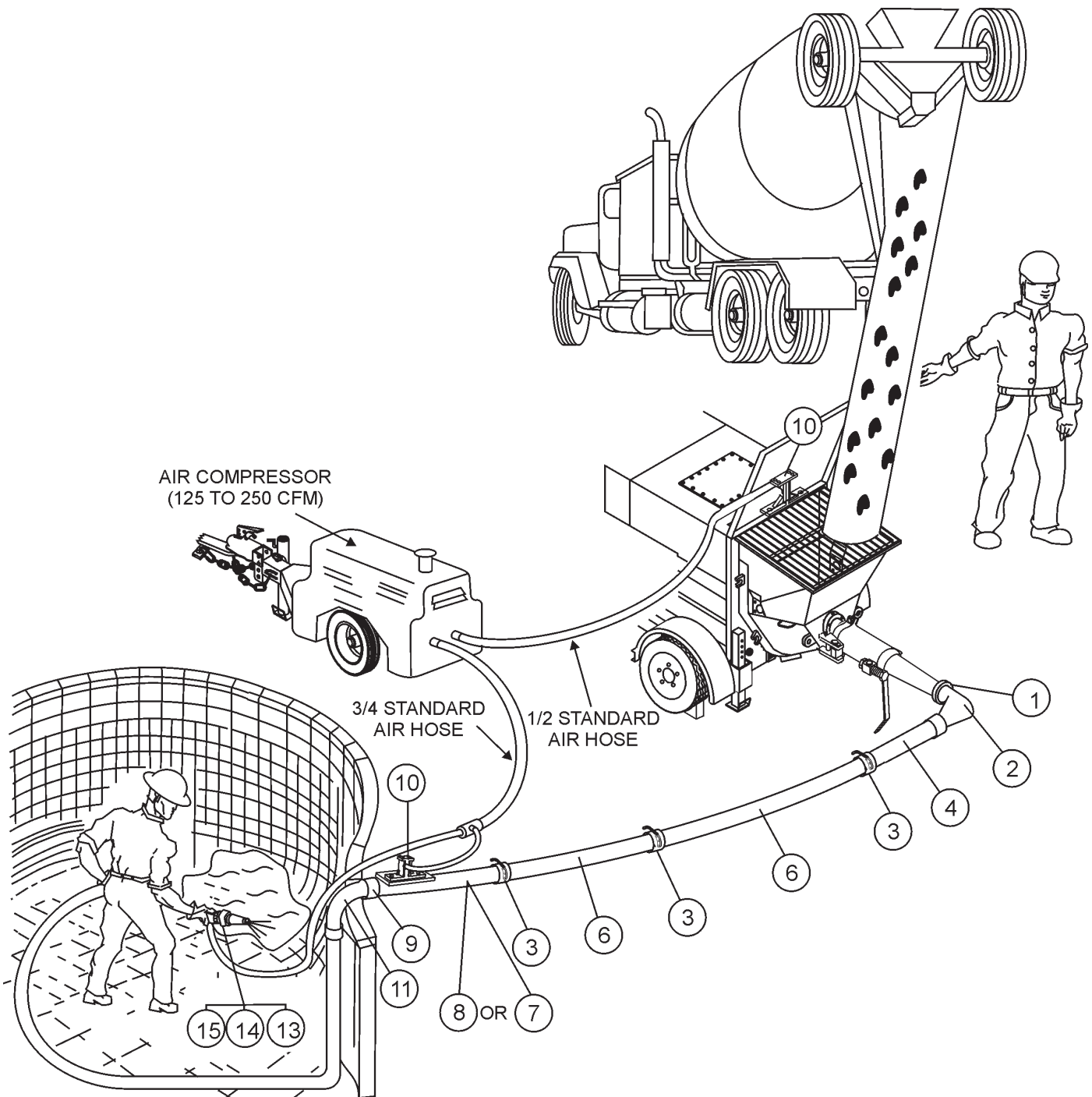

Figure 56. Recommended Shotcrete System

APPENDIX — RECOMMENDED SHOTCRETE SYSTEM

RECOMMENDED SHOTCRETE SYSTEM

<u>NO.</u>	<u>PART NO.</u>	<u>PART NAME</u>	<u>QTY.</u>	<u>REMARKS</u>
1	EM28906	COUPLING, 5" H-D "CF"		
2	EM25837	ELBOW, 5"x4"x90°		
3	EM28905	COUPLING, 4" H-D w/GASKET & PIN		
4	EM402552	REDUCER, 4"x2.5"x53" H-D ENDS		
5	EM28061	PIPE, 2.5"x120w x 10' H-D		
6	EM2890353	COUPLING, 2.5" H-D w/GASKET & PIN		
7	EM28001DD	REDUCER, 2.5"x2"x36" H-D		
8	EM23815D	REDUCER, 2.5"x2" w/AIR VIBRATOR		
9	EM28902	COUPLING, 2" H-D w/GASKET & PIN		
10	EMDC400	AIR VIBRATOR ASSY.		
11	TBD	2"x2" ELBOW		
12	EM24841	HOSE, 2"x25' H-D w/ENDS		
13	EM23808D	NOZZLE ASSEMBLY, 2" H-D		
14	EM23806	NOZZLE TIP, RUBBER 1-3/8"		
15	EM23807	NOZZLE TIP, RUBBER 1.25"		

GENERAL RECOMMENDATIONS

- If the site will permit, use steel pipe from the pump to the pool perimeter. It will reduce line pressures which is highly recommended.
- The vibrator on the reducer by the pool improves pumpability.
- Turn both air vibrators off whenever the pump is stopped to prevent separation of mix.
- The air vibrators are low consumption (4.2 scfm).
- Leave the air on at the nozzle when the pump is stopped to prevent clogging of air the hoses in the air insert.
- Use item #11 (steel elbow) at the edge of the pool to prevent collapse of the rubber hose, which can cause blockage.

APPENDIX — RECOMMENDED SHOTCRETE ACCESSORIES

RECOMMENDED SHOTCRETE ACCESSORIES

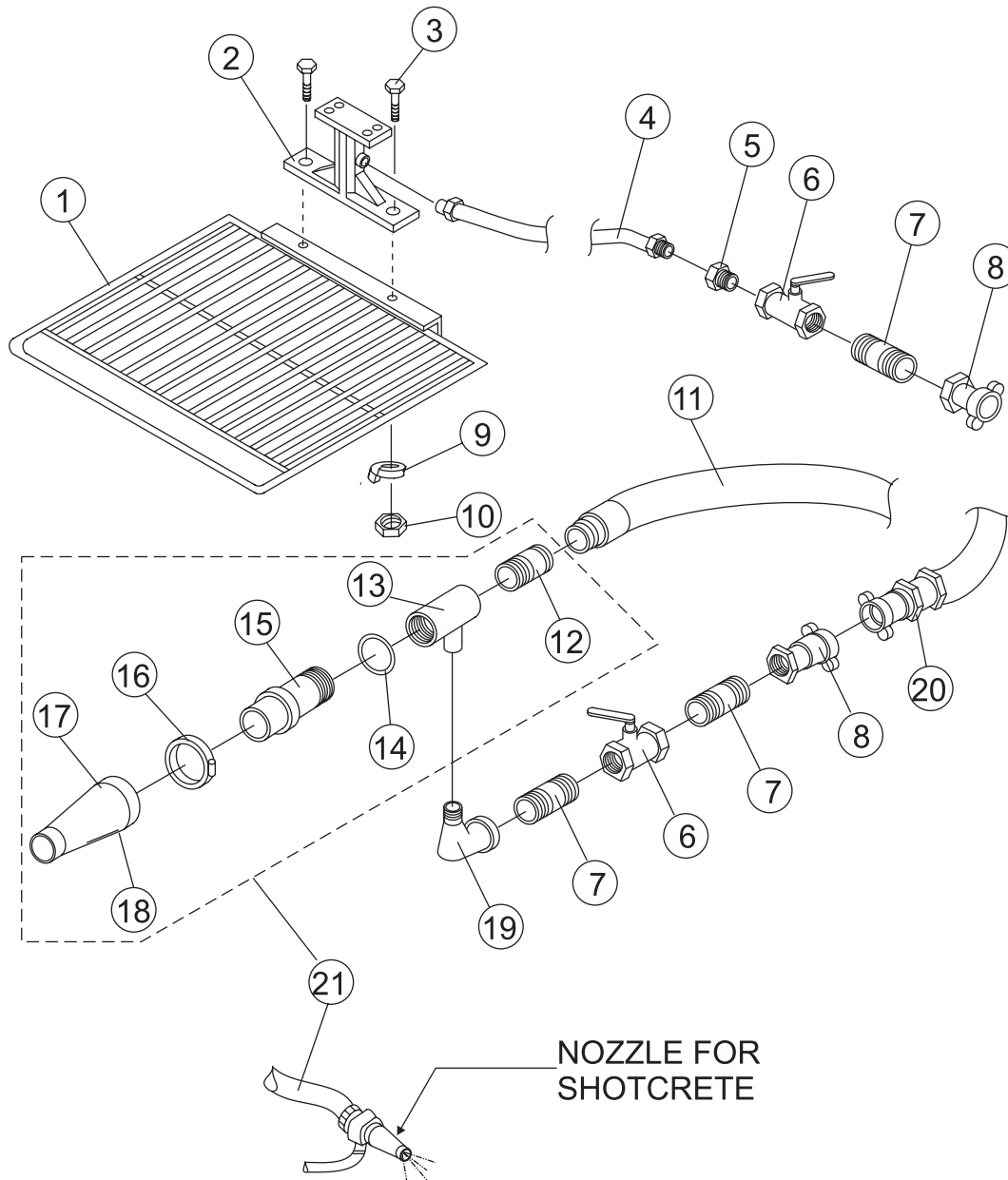
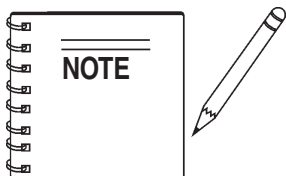

Figure 57. Shotcrete System Accessories



Use a 1-3/8" rubber nozzle tip for a wide spray pattern. Use a 1-1/4" rubber nozzle tip for a narrow spray pattern. **DO NOT INSTALL THE NOZZLE AT THE END OF THE HOSE UNTIL THE FIRST MATERIAL HAS PASSED THROUGH THE ENTIRE HOSE LENGTH.**

Disassemble and clean the nozzle assembly thoroughly after each job. Grease all threads before re-assembly. **DO NOT** close the air valve when pumping is stopped as a continued air flow keeps the air passages clean.

APPENDIX — RECOMMENDED SHOTCRETE ACCESSORIES

RECOMMENDED SHOTCRETE ACCESSORIES

<u>NO.</u>	<u>PART NO.</u>	<u>PART NAME</u>	<u>QTY.</u>	<u>REMARKS</u>
1	EM26107	HOPPER SCREEN	1	W/AIR VIBRATOR MOUNTING
2	EM23101	AIR VIBRATOR	1	
3	EM132	BOLT, 1/2-13X2	2	
4	EM23407	AIR HOSE	1	
5	EM23408	BUSHING	1	
6	EM23411	VALVE	1	
7	EM912073	NIPPLE	2	
8	EM23409	COUPLING	1	
9	EM923346	WASHER, 1/2 LOCK	2	
10	EM406	NUT, HEX 1/2-13	2	
11	EM23818	2"X25' GROOVED HOSE		
11	EM24841	2"X25' RAISED HOSE		
11	EM23845	2"X50' GROOVED HOSE		
12*	EM23802	VIC ADAPTER / EM23802D H.D	1	
13*	EM23803	GUN BODY	1	
14*	EM20816	"O" RING	1	
15*	EM23804	AIR INSERT	1	
16*	EM23805	NOZZLE CLAMP	1	
17*	EM23806	NOZZLE TIP, 1-3/8", SHORT	1	
18*	EM23807	NOZZLE TIP, 1-1/4", LONG	1	
19*	EM911076	STREET ELBOW	1	
20		AIR HOSE		NOT SUPPLIED BY MAYCO
21	EM23808	NOZZLE ASSEMBLY	1	INCLUDES ITEMS W/*

LS-60TD PUMP — TROUBLESHOOTING (PUMP)

The hydraulic troubleshooting procedures listed below are intended for use by individuals equipped with the proper tools and equipment and are familiar with hydraulic systems and safe shop practices. Use the Pump Troubleshooting Table (Table 8) to identify possible causes for the pump's malfunction. Contact the Multiquip Service department for the proper repair procedure.



WARNING - HYDRAULIC SYTEM HAZARD

DO NOT open hydraulic lines or loosen hydraulic fittings while the engine is running! Hydraulic fluid under pressure can penetrate the skin, blind, cause burns or create other potentially dangerous hazards.

TABLE 8. PUMP TROUBLESHOOTING

Problem	Possible Problem	To Troubleshoot
Main Hydraulic Cylinder will not cycle	Incorrect System Operating Pressure	Check the pump pressure gage. Verify it is approx. 3200 PSI
	Incorrect Engine RPM setting	Verify the engine's high RPM speed is set to 2350
	Contaminated Main Relief Valve	Check the manifold for a contaminated Relief Valve
	Obstructed Material Cylinders	check for obstructions (dried material) inside the cylinders
	Malfunctioning Proximity Switch	Manually cycle the pump using the manual cylinder jogging switch
	Malfunctioning Cycling Solenoid	Check for burned out solenoid and 12V signal voltage
Hopper Remix Paddles will not rotate	Malfunctioning Cycling Valve	Manually cycle the pump using the manual cylinder jogging switch
	Incorrect Directional Control Operating Pressure	Verify the Directional Control operating pressure is approx. 1550 PSI
	Contaminated Relief Valve	Check the manifold for a contaminated Relief Valve
	Broken Shaft Coupler Key	Check the Hopper Remixer shaft coupler for a broken key
	Loose Shaft Retaining Set Collar	Check the Shaft Retaining Set Collar for tightness

LS-60TD PUMP — TROUBLESHOOTING (PUMP)

TABLE 8. PUMP TROUBLESHOOTING (CONTINUED)

Shuttle Cylinder does not stroke	Incorrect Accumulator System Pressure	Check the system pressure reading. Verify it is approx. 1750 PSI
	Contaminated Relief Valve	Check the manifold for a contaminated Relief Valve
	Swing Solenoid not energizing	Check for burned out solenoid and 12V signal voltage
	Swing Valve not functioning properly	Manually cycle the pump using the manual cylinder jogging switch
Shuttle Cylinder slow to complete stroke	Improper Flow Control setting	Fully open Flow Control Valve
	Incorrect Engine RPM setting	Verify the engine's high RPM speed is set to 2350
	Incorrect Main Hydraulic System Operating Pressure	Check the pump pressure gage. Verify it is approx. 3200 PSI
	Contaminated Swing Relief Cartridge	Check the manifold for contaminated Swing Relief Cartridge
	Low Accumulator System Pressure	Check the accumulator pressure reading. Verify it is approx. 1750 PSI
	Hopper Discharge Nipple Seal improperly lubricated	Check the Hopper Discharge Nipple Seal for siezing and lack of lubricant
Pump Engine will idle but not increase to full operating speed	Throttle Control Block Solenoid not energizing	Check for burned out solenoid and 12V signal voltage
Battery Indicator Light will not illuminate and the engine will not start.	Blown out Fuse	Check the fuse
	Dead battery	Check the charge on the battery
	Wiring connection inside Control Box	Check the wiring connections and verify power is reaching ignition switch

LS-60TD PUMP — TROUBLESHOOTING (ENGINE)

Practically all breakdowns can be prevented by proper handling and maintenance inspections, but in the event of a breakdown, please take a remedial action following the diagnosis based on the Engine Troubleshooting (Table 9) information shown below and on the proceeding page. If the problem cannot be remedied, please leave the unit just as it is and consult our company's business office or service plant.

TABLE 9. ENGINE TROUBLESHOOTING

SYMPTOM	POSSIBLE PROBLEM	SOLUTION
Engine will not start or start is delayed, although engine can be turned over.	Speed control lever is in "STOP" position	Set speed control lever to "START" position.
	No fuel reaching injection pump	Add fuel. Check entire fuel system.
	Defective fuel pump	Replace fuel pump.
	Fuel filter clogged	Replace fuel filter and clean tank.
	Faulty fuel supply line	Replace or repair fuel line.
	Compression too low	Check piston, cylinder and valves. Adjust or repair per engine repair manual.
	Fuel injector not working correctly	Repair or replace injector in accordance with engine repair manual.
	Oil pressure too low	Check engine oil pressure.
	Low starting temperature limit exceeded	Comply with cold starting instructions and proper oil viscosity.
At low temperatures engine will not start.	Fuel separates has inadequate resistance to low temperatures	Check whether clear (not turbid) fuel emerges from the fuel line (detach from injection pump). If the fuel is turbid or separated, warm up the engine or drain the complete fuel supply system. Refuel with winter grade diesel fuel.
	Engine oil too thick	Refill engine crankcase with correct type of oil for winter environment.
Engine fires but stops soon as starter is switched off.	Throttle lever in STOP position	Reposition throttle lever to RUN position.
	Fuel filter blocked	Replace fuel filter.
	Fuel supply blocked	Check the entire fuel system.
Engine stops by itself during normal operation.	Fuel tank empty	Add fuel.
	Fuel filter blocked	Replace fuel filter.
Low engine power, output and speed.	Fuel tank empty	Replace fuel filter.
	Fuel filter clogged	Replace fuel filter.
	Fuel tank venting is inadequate	Ensure that tank is adequately vented.
	Speed control lever does not remain in selected position	See engine manual for corrective action.
	Engine oil level too full	Correct engine oil level?
Low engine power output and low speed, black exhaust smoke.	Air filter blocked	Clean or replace air filter.
	Incorrect valve clearances	Adjust valves per engine specification.
	Malfuction at injector	See engine manual.

LS-60TD PUMP — TROUBLESHOOTING (BRAKE SYSTEM)

Practically all breakdowns can be prevented by proper handling and maintenance inspections, but in the event of a breakdown, please take a remedial action following the diagnosis based on the Brake System Troubleshooting (Table 10) information shown below and on the proceeding page. If the problem cannot be remedied, please leave the unit just as it is and consult our company's business office or service plant.

TABLE 10. BRAKE SYSTEM TROUBLESHOOTING

SYMPTOM	POSSIBLE PROBLEM	SOLUTION
Brakes squeak, chatter or chuck.	Overheated wheel bearing	Replace wheel bearing and pack with grease.
	Low brake fluid	Fill and bleed brake system.
	Seized actuator master cylinder	Replace/Rebuild master cylinder.
	Brake shoe noise	Inspect drums. Adjust shoes or replace if necessary.
Brakes overheat, fail to operate, pull to the side, or function poorly	Leaking wheel cylinder	Check and replace wheel cylinder and bleed brake system.
	Low brake fluid level	Fill with dot approved brake fluid and bleed brake system.
	Brake actuator frame damage	Replace complete actuator unit.
	Brake line being pinched	Replace brake line.
	Seized actuator	Replace or rebuild actuator.
	Broken return spring	Replace spring.
	Brakes improperly adjusted	Check adjustment.
	Break-away cable system partially activated	Break-away cable might be pulled. Determine cause and correct. Pry up on cable until indicator bead touches or rests against cable spring stop. This will fully release the frame brakes and prevent drag.

LS SERIES PUMPS — EXPLANATION OF CODE IN REMARKS COLUMN

How to read the marks and remarks used in this parts book.

Items Found In the “Remarks” Column

Serial Numbers-Where indicated, this indicates a serial number range (inclusive) where a particular part is used.

Model Number-Where indicated, this shows that the corresponding part is utilized only with this specific model number or model number variant.

Items Found In the “Items Number” Column

All parts with same symbol in the number column, *, #, +, %, or <, belong to the same assembly or kit

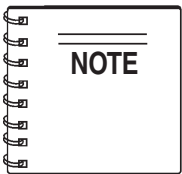

If more than one of the same reference number is listed, the last one listed indicates newest (or latest) part available.

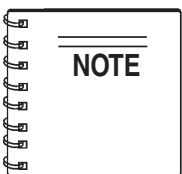

The contents of this catalog are subject to change without notice.

LS-60TD PUMP — SUGGESTED SPARE PARTS

LS-60TD STRUCTURAL CONCRETE PUMP 1 Unit

Qty.	P/N	Description
1	EM16462	FELT HOLDER
4	EM98050	PISTON CUP, ORANGE
4	EM16493	FELT RING
1	EM98033	OIL PLATE
2	EM14408	BRONZE RING
2	EM16145	BUSHING, SWING AXLE (BRONZE)
1	EM98021	WEAR PLATE
2	EM168161A	ENERGIZER RING
1	EM16816-2	INSERT RING
2	EM98065	SLEEVE SEAL
1	EM98022	WEAR RING
1	EM50417	CUP
1	EM98065	RUBBER RING
2	EM14407	O-RING
1	34507	CAP, FUEL
2	EM20763	FILTER, FUEL (IN LINE)
1	P53712	CARTRIDGE, WATER SEPERATOR
3	01174416	FILTER, OIL (ENGINE)
3	01174696	FILTER, FUEL (ENGINE)
2	EM98098P	ELEMENT, PRIMARY
2	EM98035	SLEMENT, SECONDARY

LS-60TD STRUCTURAL CONCRETE PUMP 3 Units

Qty.	P/N	Description
1	EM16459	PIN
2	EM25801	CONCRETE CYLINDER
4	EM16462	FELT HOLDER
6	EM98050	PISTON CUP, ORANGE
8	EM16493	FELT RING
4	EN98033	OIL PLATE
4	EM14408	BRONZE RING
4	EM16145A	BUSHING, SWING AXLE (BRONZE)
3	EM98021A	WEAR PLATE
4	EM168161A	ENERGIZER RING
2	EM16816-2	INSERT RING
4	EM98065	SLEEVE SEAL
6	EM98022	WEAR RING
3	EM50417	CUP
3	EM98065	RUBBER RING
6	EM14407	O-RING
2	EM16174	O-RING
1	EM98163	SWITCH, PROXIMITY
6	510265	BOLT, HEX HEAD 3/8 NC x 3-1/4 IN. G8
1	34507	CAP, FUEL
6	EM20763	FILTER, FUEL
3	P53712	CARTRIDGE, WATER SEPERATOR
9	01174416	FILTER, OIL (ENGINE)
9	01174696	FILTER, FUEL (ENGINE)
6	EM98098P	ELEMENT, PRIMARY
6	EM98035	SLEMENT, SECONDARY

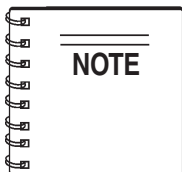

Part numbers on this Suggested Spare Parts List may supercede or replace the P/N shown in the text pages of this book.

LS-60TD PUMP — NAMEPLATE AND DECALS

NAMEPLATE AND DECALS

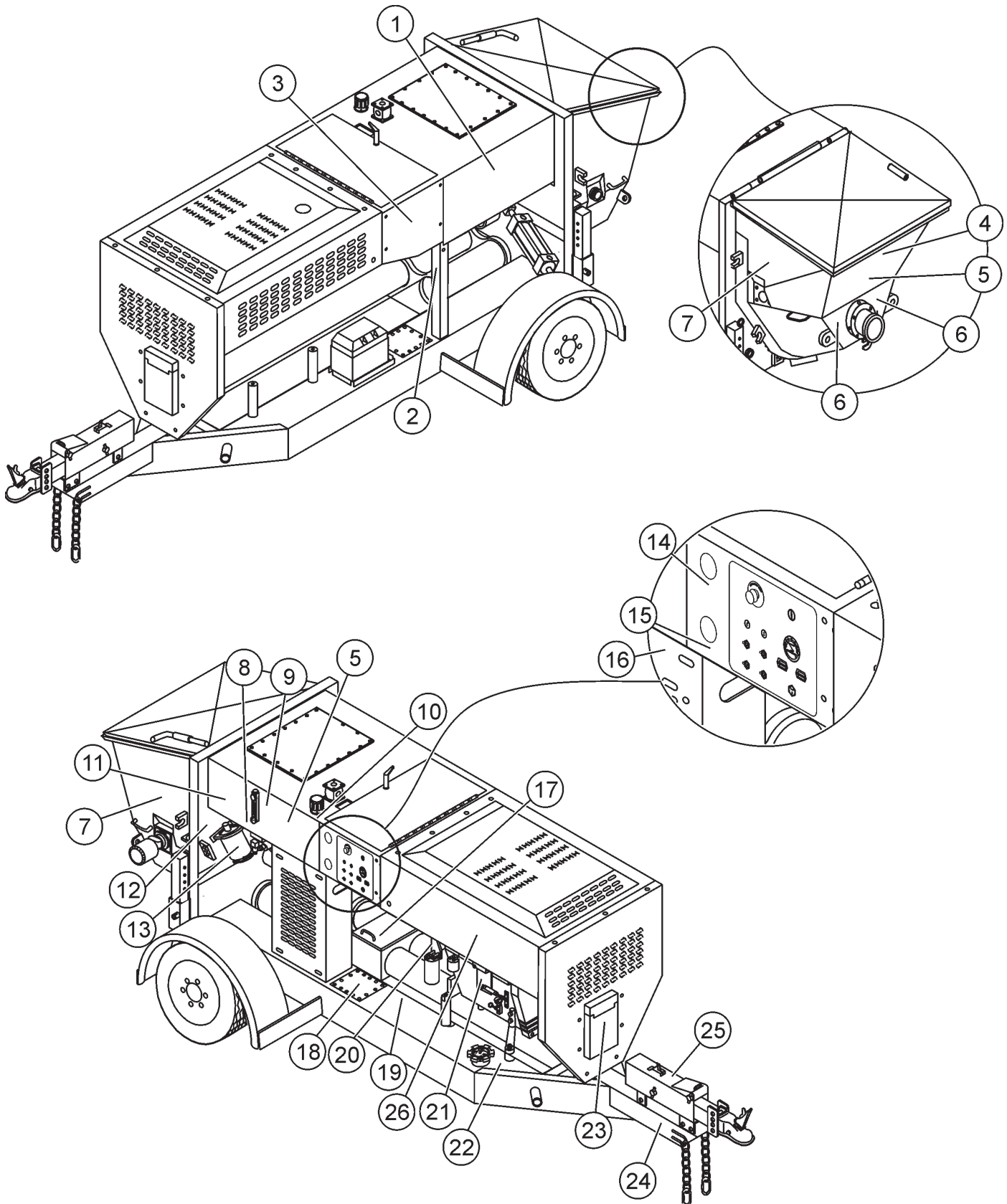

LS-60TD PUMP — NAMEPLATE AND DECALS

NAMEPLATE AND DECALS

<u>NO.</u>	<u>PART NO.</u>	<u>PART NAME</u>	<u>QTY.</u>	<u>REMARKS</u>
1	CIP514238	DECAL, LS-60 SMALL	1	
2		SERIAL PLATE	1 CONTACT PARTS DEPT.
3	DCL302	DECAL, WARNING BURN HAZARD	1	
4	511709	DECAL, 800-30-MAYCO	1	
5	EM97072	DECAL, CAUTION - OP. INSTRUCTIONS	2	
6	EM98000	DECAL, CAUTION - GREASE 2 HOURS	4	
7	DCL301	DECAL, SHUTTLE TUBE DANGER	2	
8	CIP970	DECAL, HOPPER REXMIXER	1	
9	CIP511091	DECAL, MINIMUM OIL LEVEL	1	
10	EM985	DECAL, HYDRAULIC OIL ONLY	1	
11	DCL304	DECAL, DANGER IMPROPER CHARGING	1	
12	EM97083	DECAL, WARNING - ACCUM. SAFETY	1	
13	EM955	DECAL, DANGER CHARGING ACCUM.	1	
14	EM97070	DECAL, ACCUMULATOR PRESSURE	1	
15	TBD	DECAL, PUMPING PRESSURE DECAL	1	
16	35137	DECAL, CAUTION READ MANUAL	1	
17	EM97084	DECAL, MAINTENANCE	1	
18	DCL300	DECAL, DANGER LUBRICATION BOX	1	
19	EM965	DECAL, VOLUME CONTROL	1	
20	CIP965	DECAL, THROTTLE	1	
21	CIP513580	DECAL, ENGINE RPM SETTING	1	
22	EM995	DECAL, CAUTION DIESEL FUEL	1	
23	34536	DECAL, OWNERS MANUAL	1	
24	DCL305	DECAL, WARNING REAR STABILIZERS	1	
25	EM696	DECAL, CAUTION - TOWING DECAL	1	
26	CIP514666	DECAL, LS-60 LARGE	1	

LS-60TD PUMP — FRAME ASSY.

FRAME ASSY.

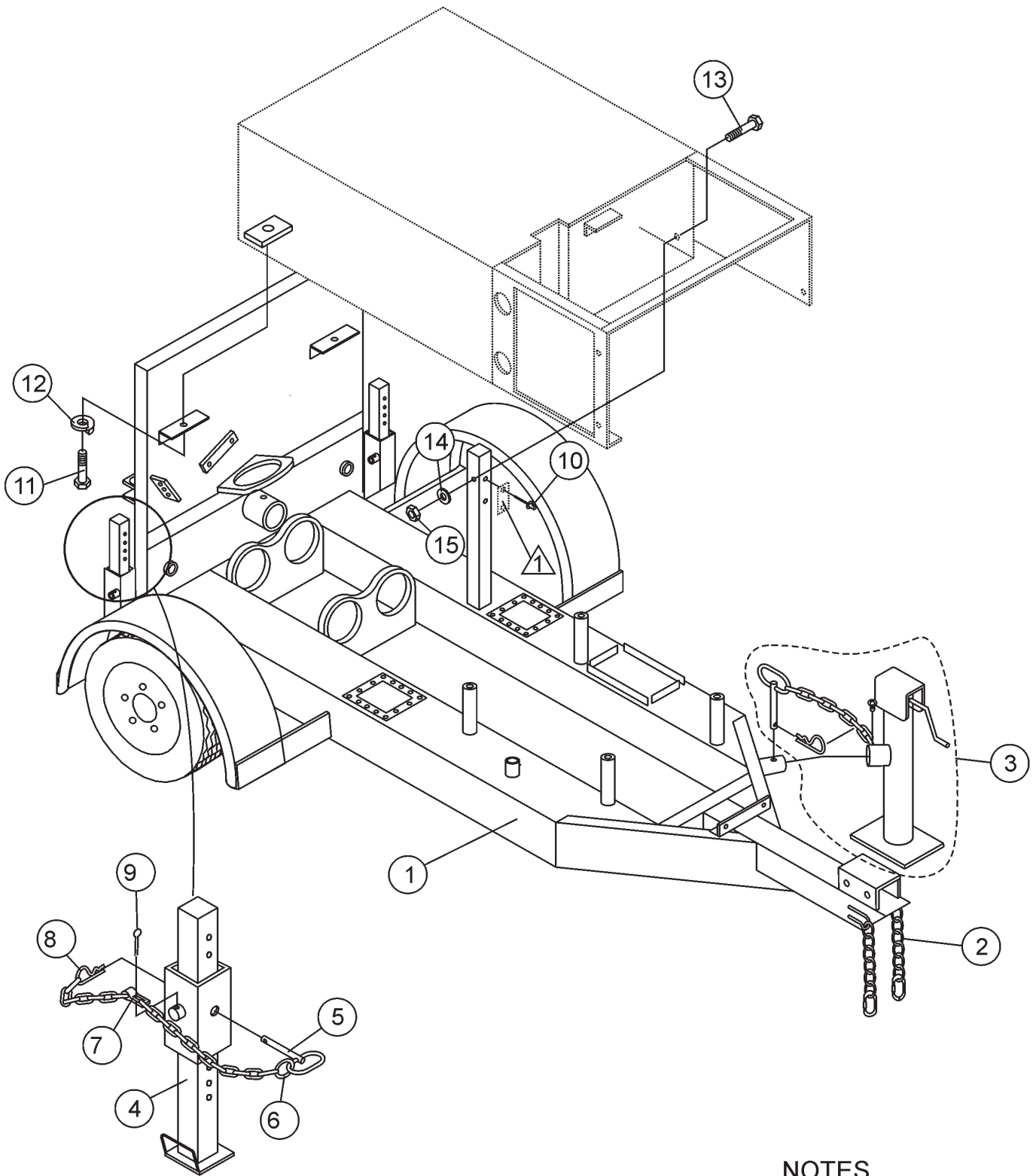

NOTES

 SEE NAMEPLATE AND DECALS
SERIAL PLATE, ITEM 2

LS-60TD PUMP — FRAME ASSY.

FRAME ASSY.

<u>NO.</u>	<u>PART NO.</u>	<u>PART NAME</u>	<u>QTY.</u>	<u>REMARKS</u>
1	CIP514355	FRAME, MAIN	1	
2	EM1005	CHAIN, TRAILER HITCH	2	
3	EM25610	JACK STAND, FRONT	1	
4	EM70186	SUPPORT STAND	2	
5	EM491686	PIN	2	
6	EM491076	PIN RING 3/4"	2	
7	EM490236	CHAIN 15 3.5 GALV.	2	
8	EM744	PIN	2	
9	491686	PIN, COTTER	2	
10	CIP491744	RIVET, POP AM-44	2	
11	CIP509562	BOLT, 3/8" NC X 5/8" G5	2	
12	CIP492624	LOCK, WASHER 3/8"	2	
13	CIP503112	BOLT 3/8" X 2-3/4"	1	
14	CIP492598	WASHER 3/8"	2	
15	CIP492583	NUT 3/8"	1	

LS-60TD PUMP — AXLE ASSY.

AXLE ASSY.

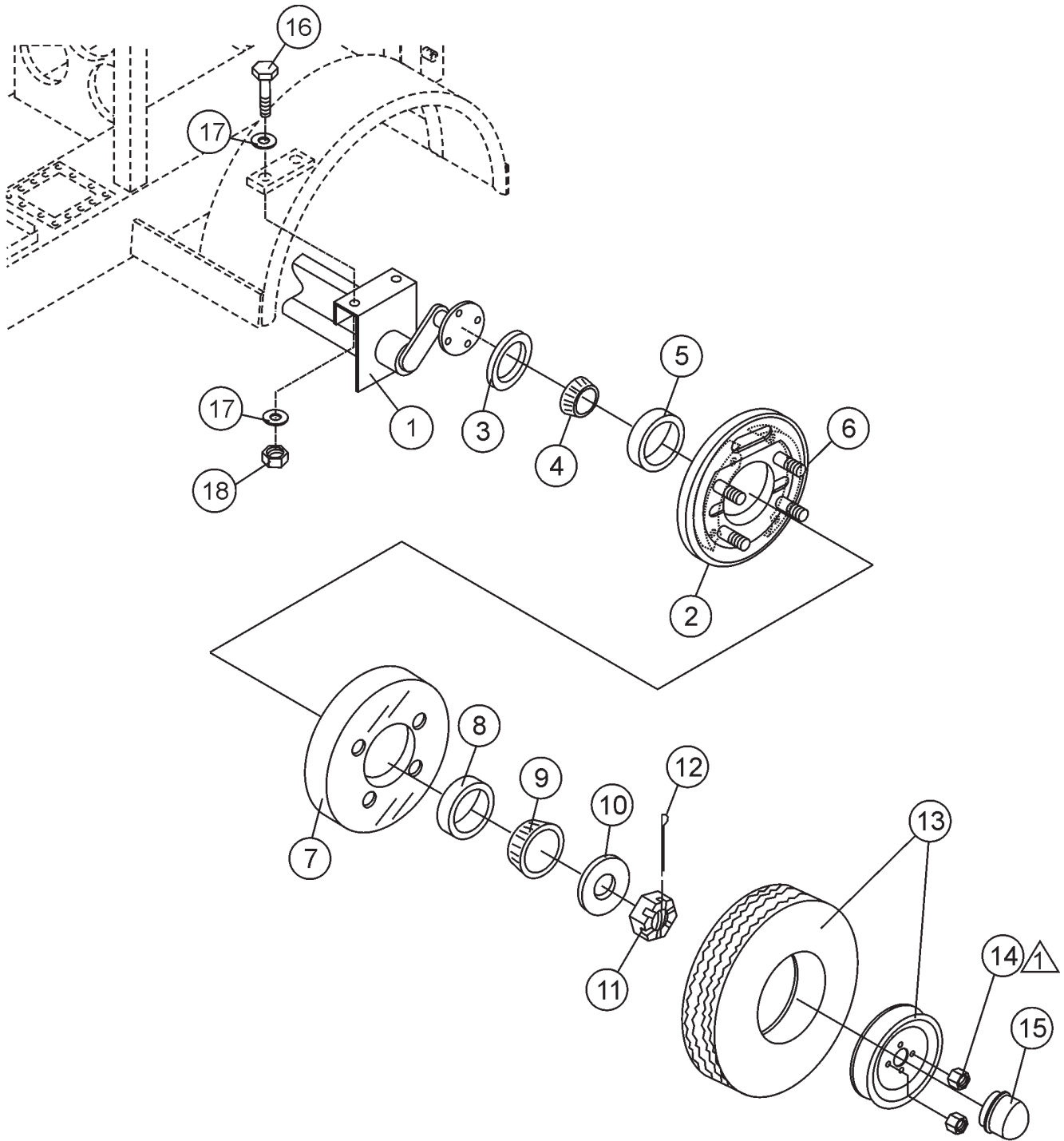

NOTES:

- TORQUE LUG NUTS PER LUG NUT
-  TORQUE TABLE REFERENCED IN THIS MANUAL.

LS-60TD PUMP — AXLE ASSY.

AXLE ASSY.

<u>NO.</u>	<u>PART NO.</u>	<u>PART NAME</u>	<u>QTY.</u>	<u>REMARKS</u>
1	EM98116	AXLE, TORSION BAR ASSY.	2	
2	302261	BRAKE	1	
3	363198	OIL SEAL	1	
4	363196	INNER BEARING CONE 2 IN.	1	
5	383911	INNER BEARING CUP 2 IN.	1	
6	363909	WHEEL STUD 1/2 IN. - 20 UNF PRESS IN	8	
7	363239	HUB AND DRUM ASSY.	2	
8	363916	OUTER BEARING CONE	1	
9	363420	OUTER BEARING CUP	1	
10	568326	LOAD WASHER 1 IN. T5 HP	1	
11	363257	SLOTTED NUT, 1 IN. UNF	2	
12	363258	COTTER PIN 3/16 IN. X 1-1/2	2	
13	EM514813	RIM AND TIRE	2	
14	363203	WHEEL LUG NUTS 1/2 UNF 60 CON	8	
15	363199	GREASE CAP	2	
16	CIP503982	BOLT, HEX HEAD 5/8 IN. NC X 2 IN. G5	4	
17	CIP492602	WASHER, FLAT 5/8 IN.	8	
18	CIP492586	NUT, LOCK 5/8 IN.	4	

LS-60TD PUMP — BRAKE LINE ASSY.

BRAKE LINE ASSY.

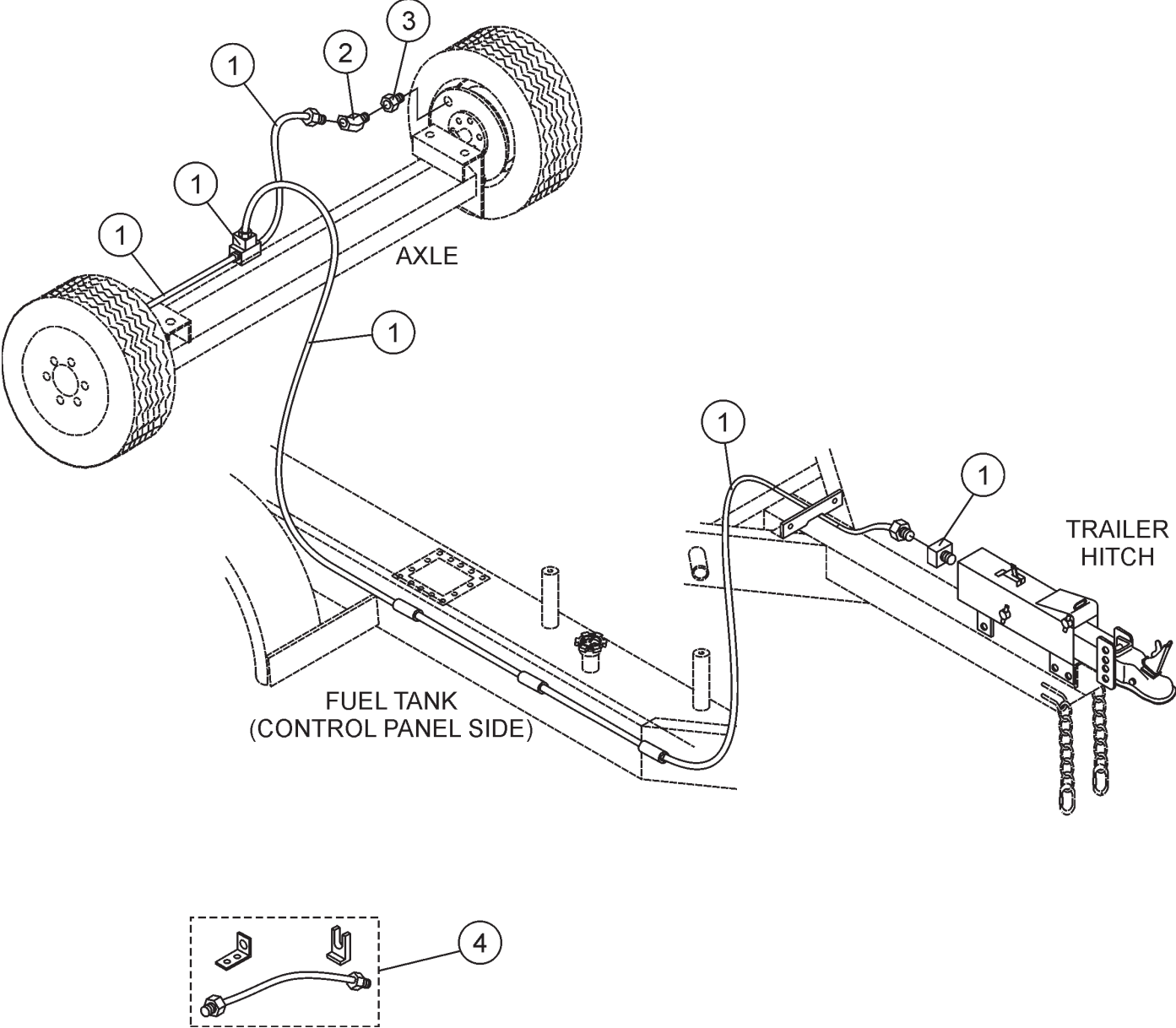

LS-60TD PUMP — BRAKE LINE ASSY.

BRAKE LINE ASSY.

<u>NO.</u>	<u>PART NO.</u>	<u>PART NAME</u>	<u>QTY.</u>	<u>REMARKS</u>
1	34566	KIT, MAIN BRAKE LINE	1	
2	CIP512877	ADAPTOR, STRAIGHT	2	
3	CIP512876	ADAPTOR, ELBOW	2	
4	34565	KIT, WHEEL BRAKE LINE	1	

LS-60TD PUMP — BRAKE LIGHT ASSY.

BRAKE LIGHT ASSY.

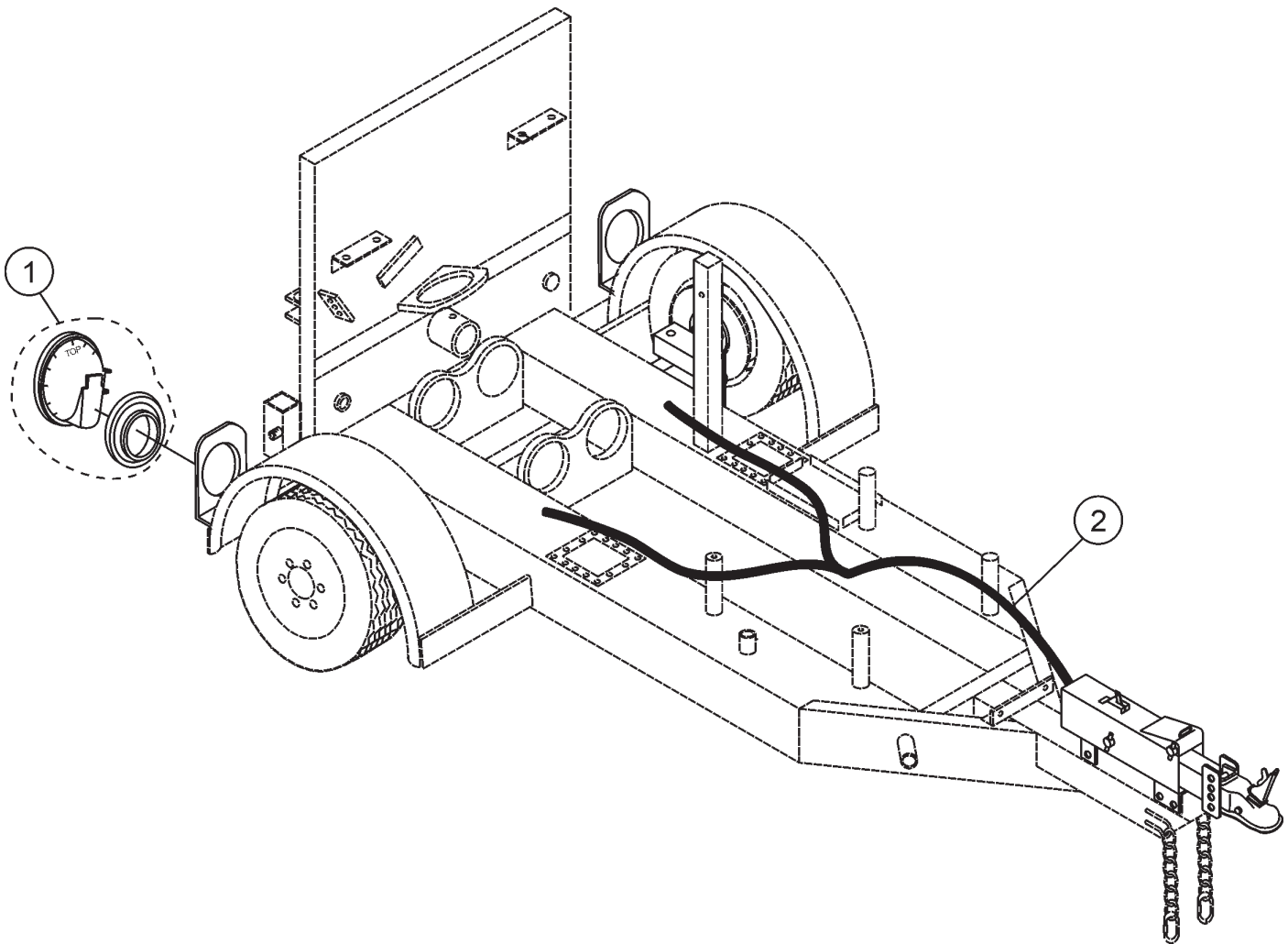

LS-60TD PUMP — BRAKE LIGHT ASSY.

BRAKE LIGHT ASSY.

<u>NO.</u>	<u>PART NO.</u>	<u>PART NAME</u>	<u>QTY.</u>	<u>REMARKS</u>
1	EM514192	BRAKE LIGHT ASSY.	2	
2	B5425Y	HARNESS ASSY. W/RECEPTACLES	1	

LS-60TD PUMP — TRAILER HITCH ASSY.

TRAILER HITCH ASSY.

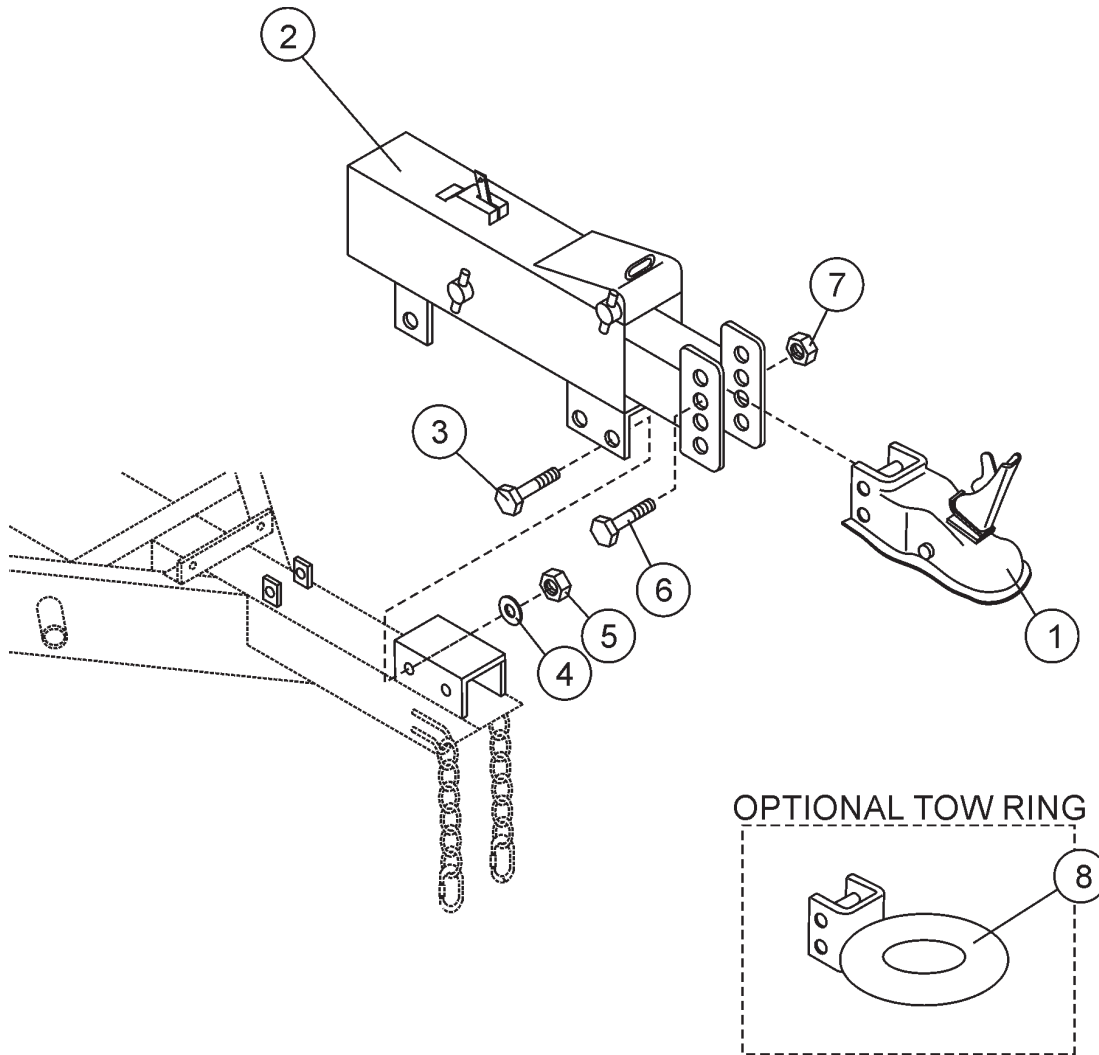

LS-60TD PUMP — TRAILER HITCH ASSY.

TRAILER HITCH ASSY.

<u>NO.</u>	<u>PART NO.</u>	<u>PART NAME</u>	<u>QTY.</u>	<u>REMARKS</u>
1	EM29228	COUPLING, TRAILER 2 IN.BALL	1	
2	EM19067	ACTUATOR, BRAKE	1	
3	EM503111	BOLT, HEX HEAD 1/2 NC X 4-1/2 IN.	3	
4	EM492600	WASHER, FLAT 1/2 IN.	3	
5	EM492584	NUT, LOCK 1/2 IN.	3	
6	EM507658	BOLT, HEX HEAD 5/8 NC X 4-1/2 IN. G5	2	
7	EM492586	NUT, LOCK 5/8 IN.	2	
8	16137	TOW RING, 3 IN. LUNETTE EYE	1	

LS-60TD PUMP — BATTERY ASSY.

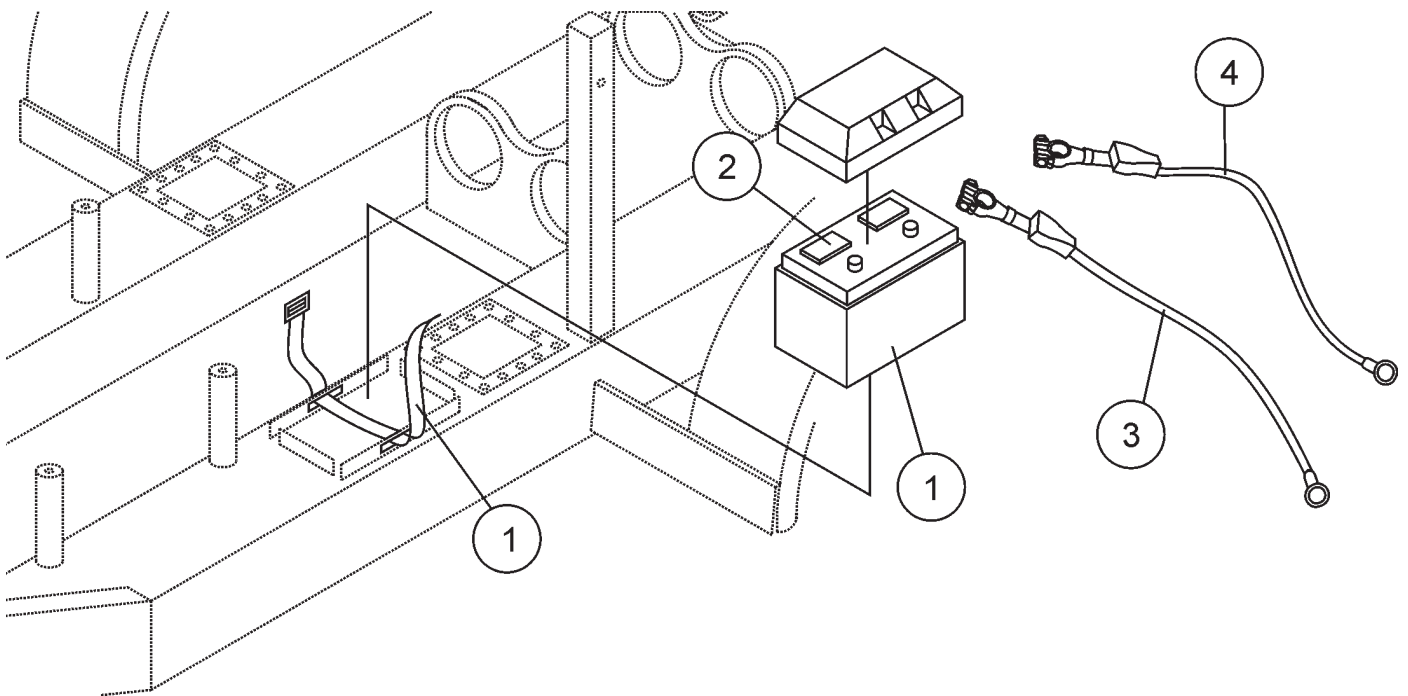

LS-60TD PUMP — BATTERY ASSY.

MANIFOLD ASSY.

<u>NO.</u>	<u>PART NO.</u>	<u>PART NAME</u>	<u>QTY.</u>	<u>REMARKS</u>
1	EM34506	BATTERY BOX W/ BELT	1	
2	EM16738	BATTERY 12V 125A	1	
3	CIP514856	BATTERY CABLE POSITIVE	1	
4	CIP513577	BATTERY CABLE NEGATIVE	1	

LS-60TD PUMP — HOPPER ASSY.

HOPPER ASSY.

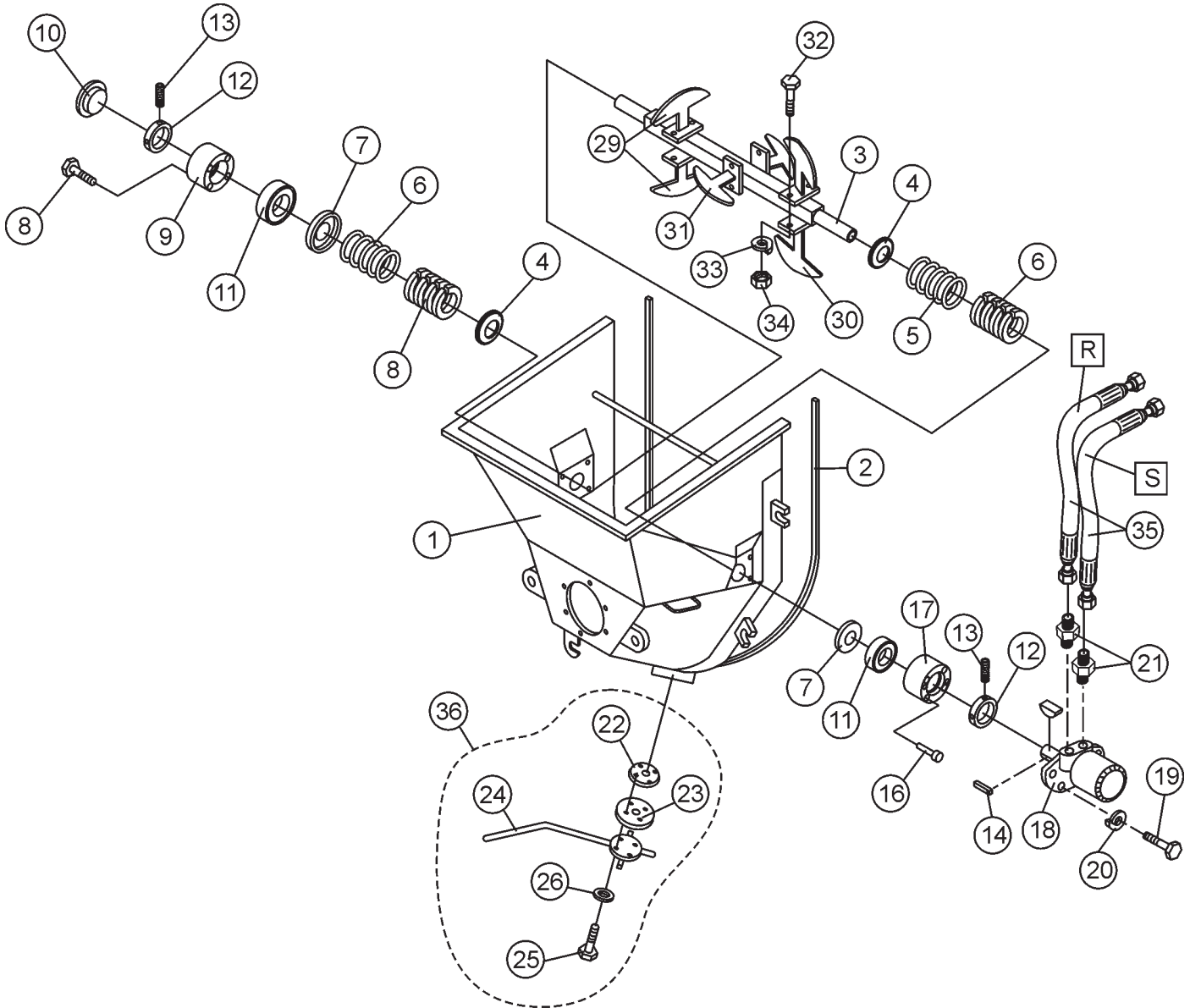

NOTES

- R** HYDRAULIC HOSE CONNECTIONS
- S** SEE PARTS LIST FOR DETAILS

LS-60TD PUMP — HOPPER ASSY.

HOPPER ASSY.

<u>NO.</u>	<u>PART NO.</u>	<u>PART NAME</u>	<u>QTY.</u>	<u>REMARKS</u>
1	EM25174	HOPPER ASSY	1	
2	EM16184	HOPPER SEAL	1	
3	CIP514056	REMIXER SHAFT	1	
4	EM200303	FOLLOWER RING	2	
5	EM200301	GRAPHITE SEAL	8	
6	CIP514341	COMPRESSION SPRING	2	
7	CIP514339	HOPPER SPRING SEAL	2	
8	CIP510717	BOLT 1/2 X 1-3/4 IN.	4	
9	CIP514338	SUPPORT, LEFT	1	
10	CIP514706	END CAP, SHAFT SUPPORT	1	
11	EM902153	BEARING	2	
12	EM200018	SET COLLAR	2	
13	CIP492470	SET SCREW	4	
14	CIP514625	KEY 1/4 IN.	1	
16	CIP505990	BOLT 1/2 X 2-1/2 IN.	4	
17	CIP514337	MOTOR MOUNT SUPPORT	1	
18	EM98108	MOTOR, REMIX	1	
19	CIP505989	BOLT 1/2 X 1-1/4 IN.	2	
20	CIP492626	WASHER, LOCK 1/2 IN.	2	
21	EM25508	ADAPTER, FITTING	2	
22	EM70860-1	PISTON CUP HOLDER	1	
23	EM50417	PISTON CUP	1	
24	CIP508830	HANDLE	1	
25	CIP492378	BOLT 3/8 X 1-3/4 IN.	4	
26	CIP492624	WASHER, LOCK 3/8 IN.	4	
29	CIP514031	PADDLE ARM, END	2	
30	CIP514032	PADDLE ARM, MOTOR END	2	
31	CIP514033	PADDLE ARM, CENTER	2	
32	CIP492626	BOLT 1/2 X 3-1/4 IN.	6	
33	CIP492626	WASHER, LOCK 1/2 IN.	6	
34	CIP507661	HEX NUT 1/2 IN.	6	
35	EM25483	HOSE	2	CONNECT TO REMIX VALVE, HOSE R & HOSE S
36	EM70860	HANDLE ASSY.	1	

LS-60TD PUMP — HOPPER ATTACHMENT ASSY.

HOPPER ATTACHMENT ASSY.

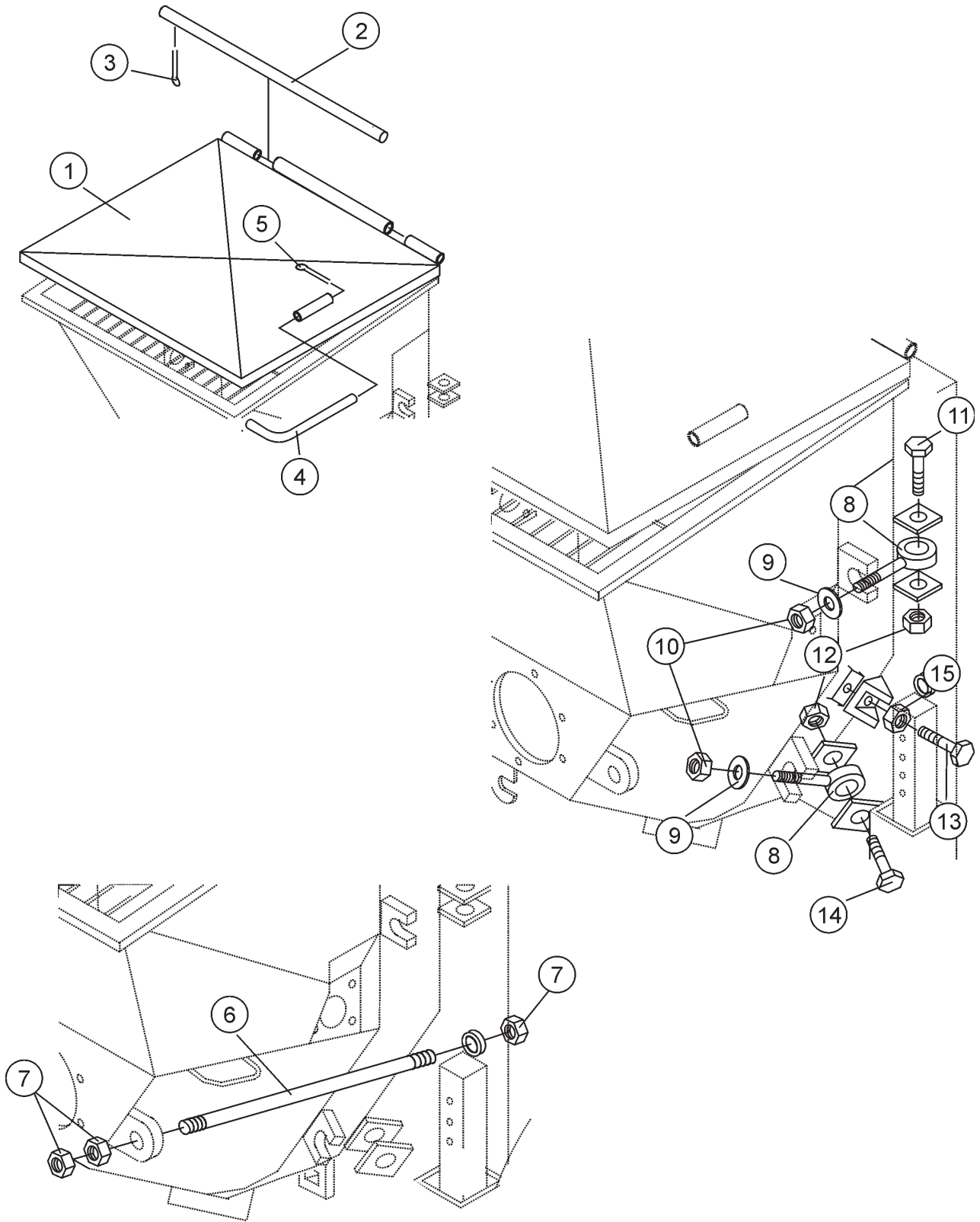

LS-60TD PUMP — HOPPER ATTACHMENT ASSY.

HOPPER ATTACHMENT ASSY.

<u>NO.</u>	<u>PART NO.</u>	<u>PART NAME</u>	<u>QTY.</u>	<u>REMARKS</u>
1	514204	SPLASH PLATE	1	
2	514620	HINGE PIN	1	
3	CIP491686	COTTER PIN 1/8 X 1-1/2 IN.	1	
4	EM70134-2	PIN, SPLASH PLATE	1	
5	505723	COTTER PIN 5/32 X 1-1/2 IN.	1	
6	EM16166	TIE ROD	1	
7	CIP505728	NUT, HEX 1 IN. NC	6	
8	EM14165	EYE BOLT 3/4 IN.	4	
9	EM619	O-RING 3/4 IN.	4	
10	EM968446	NUT, HEX 3/4 IN.	4	
11	CIP505121	BOLT 3/4 IN. X 3 IN.	4	
12	CIP492558	HEX NUT 3/4 IN.	4	
13	CIP505123	HEX BOLT 1/2 X 2-1/2 IN.	2	
14	CIP492491	HEX BOLT 1/2 X 1-1/2 IN.	1	
15	CIP492556	HEX NUT 1/2 IN.	3	

LS-60TD PUMP — HOPPER INTERIOR ASSY.

HOPPER INTERIOR ASSY.

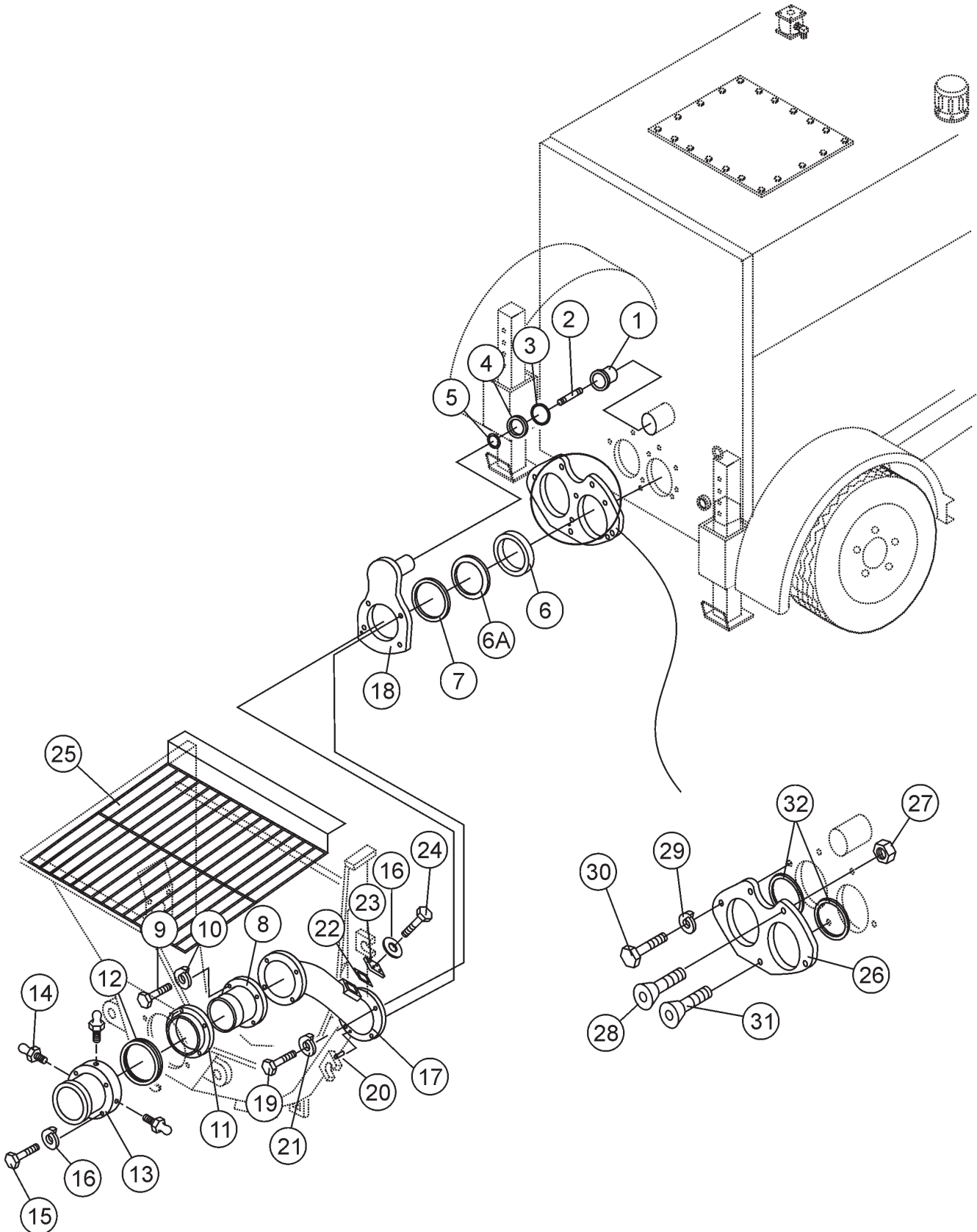

LS-60TD PUMP — HOPPER INTERIOR ASSY.

HOPPER INTERIOR ASSY.

<u>NO.</u>	<u>PART NO.</u>	<u>PART NAME</u>	<u>QTY.</u>	<u>REMARKS</u>
1	EM16145	SWING AXLE BUSHING	2	
2	EM284	STUD 1 IN. - 14 UNF	1	
3	EM16175	O-RING	1	
4	EM16170	RING SEAL, SHUTTLE AXLE	1	
5	EM16176	O-RING	1	
6	EM98022	WEAR RING HF	1	
6A	EM16816-1A	RING, ENERGIZER RUBBER	1	
7	EM16816-2	RING, INSERT STEEL	1	
8	EM16804	SLEEVE 5 IN.	1	
9	CIP503982	BOLT 5/8 X 2 IN.	4	
10	CIP492627	WASHER, LOCK 5/8 IN.	4	
11	EM25803	DISCHARGE PLATE BEARING	1	
12	EM98065	SEAL, RUBBER	1	
13	CIP512212	DISCHARGE NIPPLE	1	
14	CIP491701	GREASE FITTING	3	
15	CIP210	BOLT 5/8 X 2 IN.	6	
16	CIP492626	WASHER, LOCK 1/2 IN.	6	
17	EM16811	SHUTTLE CYLINDER	1	
18	EM25843	NUN PLATE	1	
19	CIP503982	BOLT, HEX HEAD 5/8 X 2 IN.	4	
20	491719	PIN	1	
21	EM923348	WASHER, LOCK 5/8 IN.	4	
22	EM20816	O- RING	1	
23	EM16802	INSPECTION PLATE	1	
24	EM963102	CAP SCREW, HEX BOLT	4	
25	CIP514357	HOPPER SCREEN	1	
26	EM98021	PLATE, WEAR HF	1	
27	CIP492586	NUT, HEX 5/8 IN. NC INS.	2	
28	EM265	BOLT, COUNTER SUNK 5/8-11 x 3 IN.	2	
29	EM492628	WASHER, LOCK 3/4 IN.	2	
30	EM151	BOLT, HEX HEAD 3/4-10 X 2 IN.	2	
31	EM264	BOLT, COUNTER SUNK 1/2-13 x 3 IN.	2	

LS-60TD PUMP — SHUTTLE CYLINDER ASSY.

SHUTTLE CYLINDER ASSY.

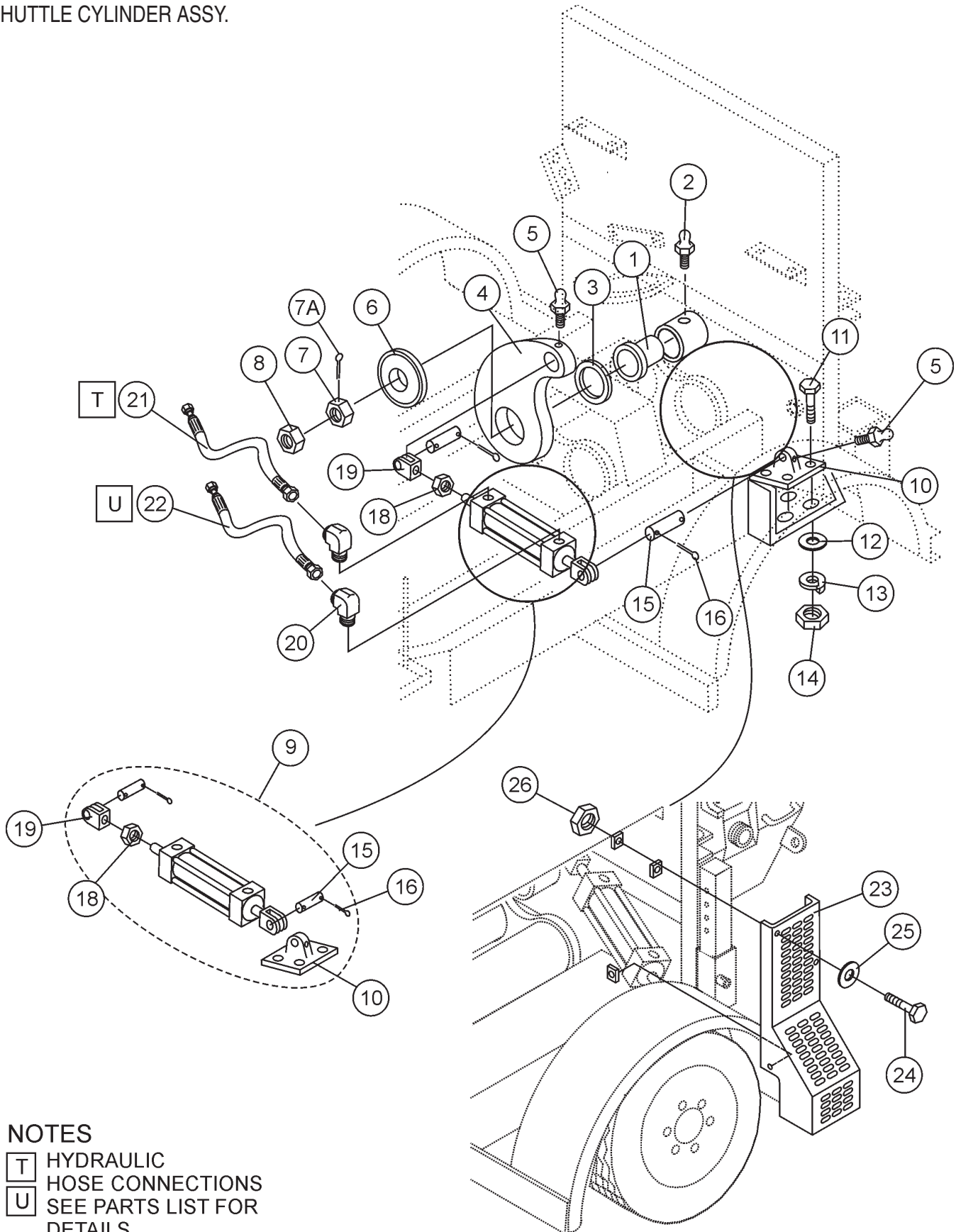

NOTES

- T** HYDRAULIC HOSE CONNECTIONS
- U** SEE PARTS LIST FOR DETAILS

LS-60TD PUMP — SHUTTLE CYLINDER ASSY.

SHUTTLE CYLINDER ASSY.



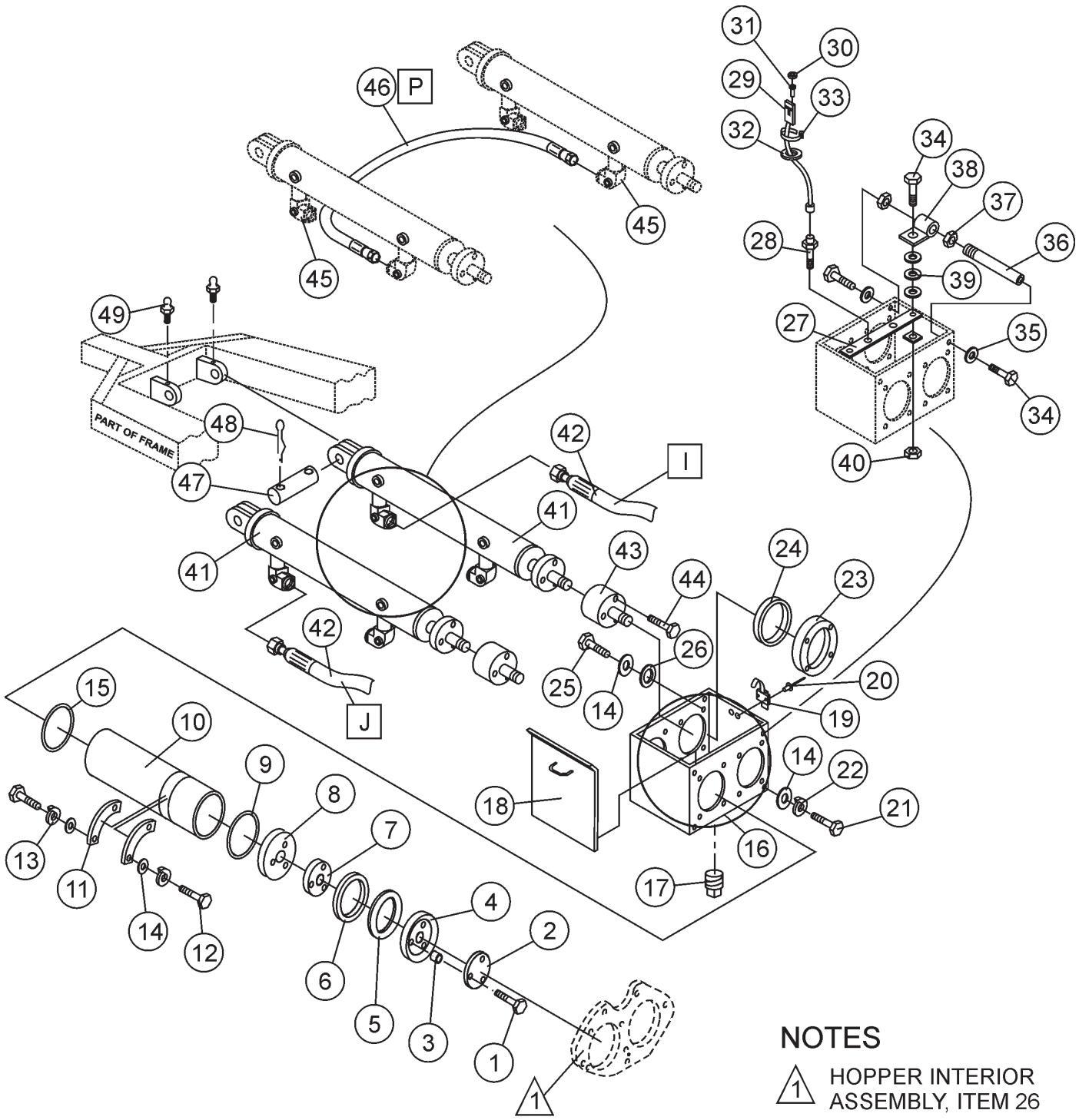

<u>NO.</u>	<u>PART NO.</u>	<u>PART NAME</u>	<u>QTY.</u>	<u>REMARKS</u>
1	EM16145	SWING AXLE BUSHING	2	
2	CIP510684	GREASE FITTING	1	
3	EM16169	THRUST WASHER	1	
4	EM25236	SHUTTLE CRANK, SPLINED SHAFT	1	
5	CIP505490	GREASE FITTING	2	
6	EM16814	TENSIONER	1	
7	CIP491690	HEX NUT 1 IN. 14NF	1	
7A	EM924006	COTTER PIN 5/32 X 2 IN.	1	
8	CIP417	NUT 1 IN. 14NF	1	
9	EM98106	SHUTTLE CYLINDER ASSY.	1	INCLUDES ITEMS W/*
10*	EM254549	BRACKET, PIVOT	1	
11	CIP492397	BOLT 1/2 X 2-1/2 IN.	4	
12	CIP621	WASHER 1/2 IN.	4	
13	CIP492626	WASHER, LOCK 1/2 IN.	4	
14	CIP492584	NUT 1/2 IN.	4	
15*	0820270000	CLEVIS PIN 3/4 IN.	2	
16*	0820270000	COTTER PIN	2	
18*	575249	JAM NUT	1	
19*	0509440000	FEMALE CLEVIS	2	
20	CIP3322	FITTING, ELBOW	2	
21	CIP514590	HOSE	1	CONNECT TO MANIFOLD PORT "A1"
22	CIP514591	HOSE	1	CONNECT TO MANIFOLD PORT "B1"
23	TBD	COVER, SHUTTLE CYLINDER	1	
24	TBD	BOLT	3	
25	TBD	WASHER, FLAT	3	
26	TBD	NUT, HEX	3	

LS-60TD PUMP — LUBRICATION PISTONS ASSY.

LUBRICATION PISTONS ASSY.



NOTES

-  HOPPER INTERIOR ASSEMBLY, ITEM 26
-   HYDRAULIC HOSE CONNECTIONS
-  SEE PARTS LIST FOR DETAILS

LS-60TD PUMP — LUBRICATION PISTONS ASSY.

LUBRICATION PISTONS ASSY.

<u>NO.</u>	<u>PART NO.</u>	<u>PART NAME</u>	<u>QTY.</u>	<u>REMARKS</u>
1	EM963064	BOLT, HEX HEAD 3/8 NC X 3-1/4 IN. G8	6	
2	EM16464	FACE PLATE	2	
3	EM16465	PISTON CUP SPACER	6	
4	EM98050	CUP, PISTON- ORANGE	2	
5	EM14408	RING, BRONZE	2	
6	EM16493	RING, FELT	2	
7	EM16462	FELT HOLDER	2	
8	EM16461	OILER PLATE	2	
9	EM14407	O- RING, OILER PLATE	2	
10	EM25801	CYLINDER, CONCRETE	2	
11	EM25110	RETAINER, CYLINDER	4	
12	CIP492375	BOLT, 3/8 NC X 1.3/4 IN. G5	8	
13	CIP492624	WASHER LOCK 3/8 IN.	8	
14	CIP492598	WASHER, FLAT 3/8 IN.	22	
15	EM16174	O- RING	2	
16	CIP514197	LUBRICATION BOX	1	
17	CIP507895	PLUG	1	
18	CIP514203	COVER, LUBRICATION BOX	1	
19	CIP514610	LATCH, COVER	1	
20	CIP491754	RIVET, AM-66	2	
21	CIP492378	BOLT, 3/8 NC X 1.3/4 IN. G5	6	
22	CIP492624	WASHER, LOCK 3/8"	6	
23	EM50425	FLANGE, RING	2	
24	EM27435	SEAL LUBE BOX	2	
25	CIP492451	BOLT 3/8 - 24 X 1 IN. HEX HEAD	8	
26	EM50443	SEAL, OIL BOX	8	
27	CIP514208	BAR, PROXIMITY SWITCH SUPPORT	1	
28	EM98163	SWITCH, PROXIMITY W/CABLE	1	
29	EM98135	CABLE HOUSING, FEMALE	2	
30	EM98134	SEAL, CONNECTOR HOUSING	6	
31	EM98138	TERMINAL PIN, FEMALE	6	
32	CIP514611	GROMMET	2	
33	CIP504505	WRAP TIE	8	

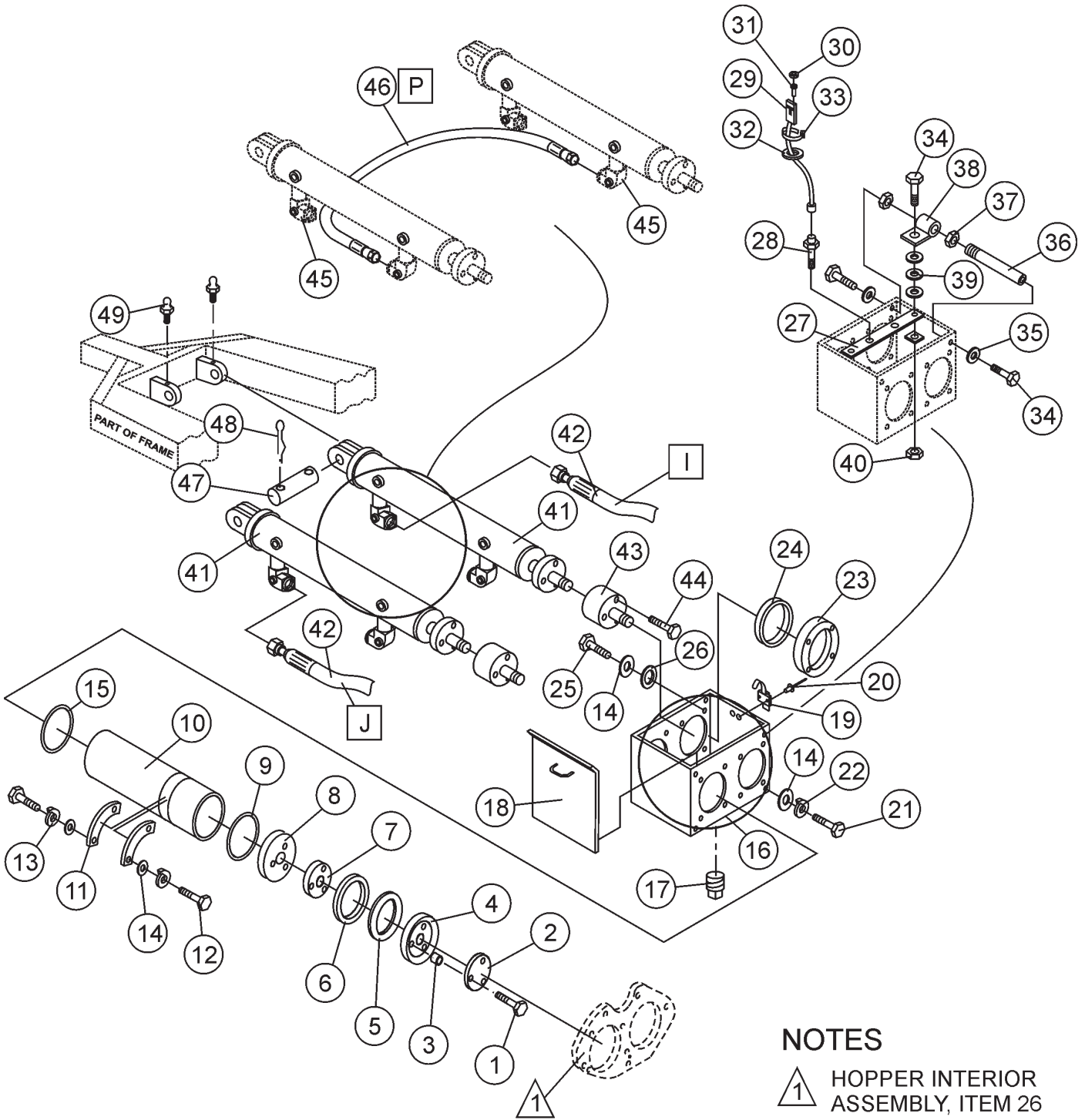

LS-60TD PUMP — LUBRICATION PISTONS ASSY.

LUBRICATION PISTONS ASSY.



NOTES

 HOPPER INTERIOR ASSEMBLY, ITEM 26

  HYDRAULIC HOSE CONNECTIONS
 SEE PARTS LIST FOR DETAILS

LS-60TD PUMP — LUBRICATION PISTONS ASSY.

LUBRICATION PISTONS ASSY.

<u>NO.</u>	<u>PART NO.</u>	<u>PART NAME</u>	<u>QTY.</u>	<u>REMARKS</u>
34	492366	BOLT, HEX HEAD 5/16 NC X 1 IN. G5	6	
35	EM492623	WASHER, LOCK 5/16 IN.	4	
36	EM514216	ADJUSTMENT ROD, PROXIMITY SWITCH	2	
37	EM492556	NUT, HEX 1/2 IN.	4	
38	EM514207	BRACKET, ADJUSTMENT ROD	2	
39	EM492597	WASHER, FLAT 5/16 IN.	6	
40	EM492582	NUT, HEX HEAD 5/16 IN	2	
41	EM98211	CYLINDER, DRIVE	2	
42	514920	HOSE, MAIN HYD. CYLINDER	2	
43	EM514202	EXTENSION, SPACER	2	
44	EM185	BOLT, SOCKET HEAD 3/8 NC X 3 IN.	6	
45	EM25497	FITTING, 90°	4	
46	EM25474	HOSE, HYDRAULIC SLAVE	1	
47	EM16459	PIN, WRIST	2	
48	EM505723	PIN, COTTER	4	
49	EM491701	FITTING, GREASE	2	

LS-60TD PUMP — FUEL TANK ASSY.

FUEL TANK ASSY.

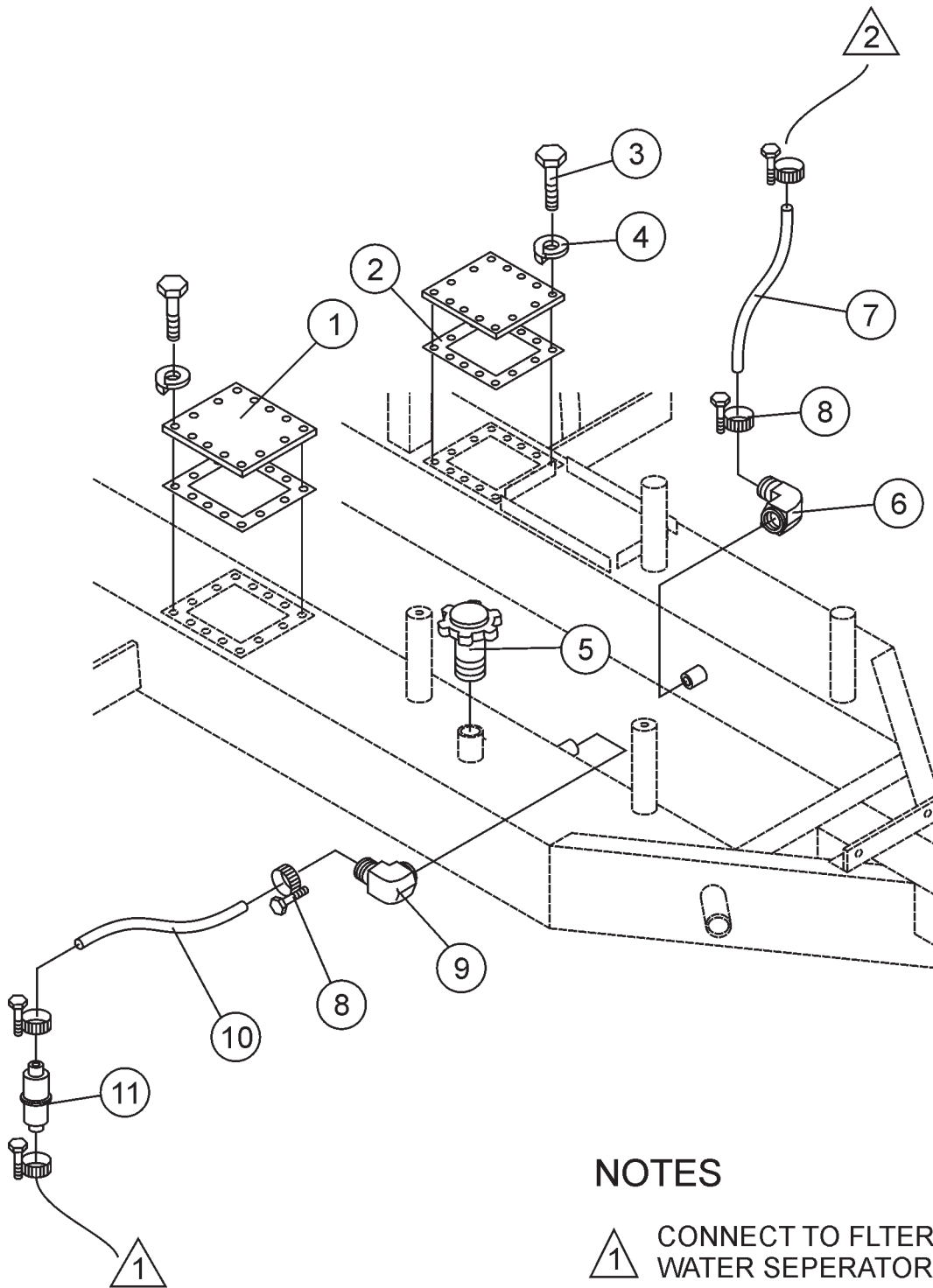

NOTES

1 CONNECT TO FILTER INLET HOSE
WATER SEPERATOR ASSY., NOTE 1

2 CONNECT TO FILTER OUTLET HOSE
WATER SEPERATOR ASSY., NOTE 2

LS-60TD PUMP — FUEL TANK ASSY.

FUEL TANK ASSY.

<u>NO.</u>	<u>PART NO.</u>	<u>PART NAME</u>	<u>QTY.</u>	<u>REMARKS</u>
1	CIP514084	COVER, DIESEL TANK	2	
2	CIP514080	GASKET	2	
3	CIP492362	BOLT 5/16 X 5/8 IN.	28	
4	CIP492623	WASHER, LOCK 5/16 IN.	28	
5	CIP34507	CAP, FUEL W/GAUGE	1	
6	CIP514559	ADAPTOR	1	
7	CIP506208	CLAMP	5	
8	CIP514536	HOSE, FUEL RETURN 5/16 IN.	A/R	
9	EM20426	ADAPTER	1	
10	514536	HOSE, FUEL FILTER 5/16 IN.	A/R	
11	EM20763	FILTER, FUEL	2	

LS-60TD PUMP — HEAT EXCHANGER ASSY.

HEAT EXCHANGER ASSY.

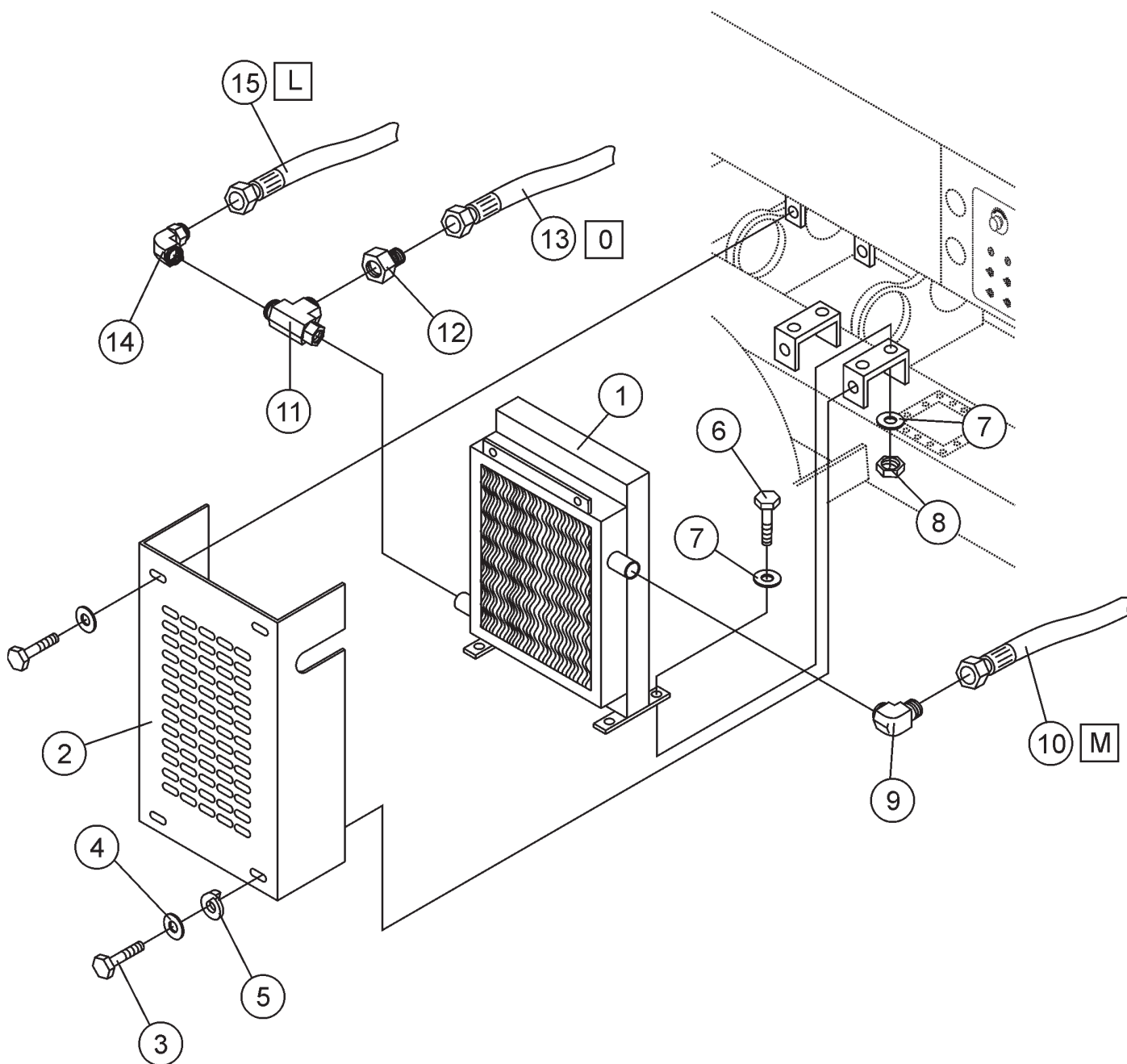

NOTES

- L M HYDRAULIC HOSE CONNECTIONS
- O SEE PARTS LIST FOR DETAILS

LS-60TD PUMP — HEAT EXCHANGER ASSY.

HEAT EXCHANGER ASSY.

<u>NO.</u>	<u>PART NO.</u>	<u>PART NAME</u>	<u>QTY.</u>	<u>REMARKS</u>
1	EM98118	HEAT EXCHANGER	1	
2	CIP514175	COVER, HEAT EXCHANGER	1	
3	CIP492375	BOLT 3/8 IN. X 1 IN.	4	
4	CIP492598	O-RING 3/8 IN.	4	
5	CIP492624	WASHER, LOCK 3/8 IN.	4	
6	CIP492364	BOLT 5/16 X 1 IN.	4	
7	CIP492597	WASHER, FLAT 5/16 IN.	8	
8	CIP492582	NUT 5/16 IN.	4	
9	EM25497	ADAPTER	1	
10	CIP514607	HOSE 4000 PSI	1	CONNECT TO RETURN FILTER, HOSE M
11	CIP25566	ADAPTER	1	
12	CIP509345	ADAPTER	1	
13	CIP514606	HOSE 2000 PSI	1	CONNECT TO REMIXER VALVE, HOSE O
14	CIP509401	ADAPTER	1	
15	CIP514604	HOSE, 2000 PSI	1	CONNECT TO MANIFOLD PORT "T2"

LS-60TD PUMP — ACCUMULATOR ASSY.

ACCUMULATOR ASSY.

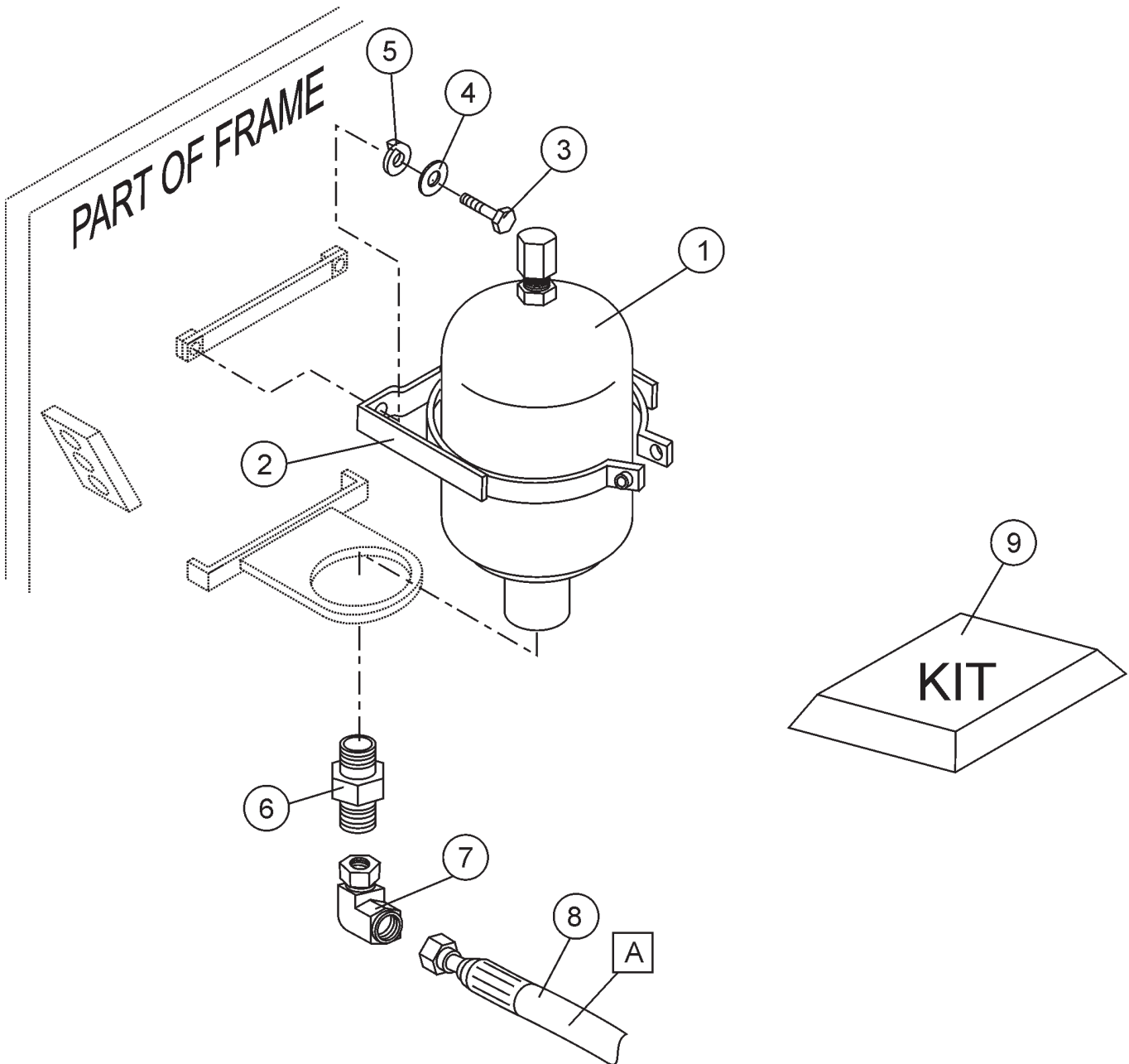

NOTES

- A** HYDRAULIC HOSE CONNECTIONS SEE PARTS LIST FOR DETAILS

LS-60TD PUMP — ACCUMULATOR ASSY.

ACCUMULATOR ASSY.

<u>NO.</u>	<u>PART NO.</u>	<u>PART NAME</u>	<u>QTY.</u>	<u>REMARKS</u>
1	EM97015	ACCUMULATOR 1 GAL.	1	
2	EM97016	BRACKET, ACCUMULATOR	1	
3	EM9603055	BOLT, HHCS 3/8 IN. DIA.	2	
4	3019092	WASHER, FLAT 3/8 IN.	2	
5	0166A	WASHER, LOCK 3/8 IN. DIA.	2	
6	EM509425	FITTING, STRAIGHT	1	
7	EM509353	FITTING, 90° ELBOW	1	
8	CIP514603	HOSE, ACCUMULATOR	1	CONNECT TO MANIFOLD PORT "ACC"
9	EM98009	ACCUMULATOR REPAIR KIT	1	

LS-60TD PUMP — REMIXER CONTROL ASSY.

REMIKER CONTROL ASSY.

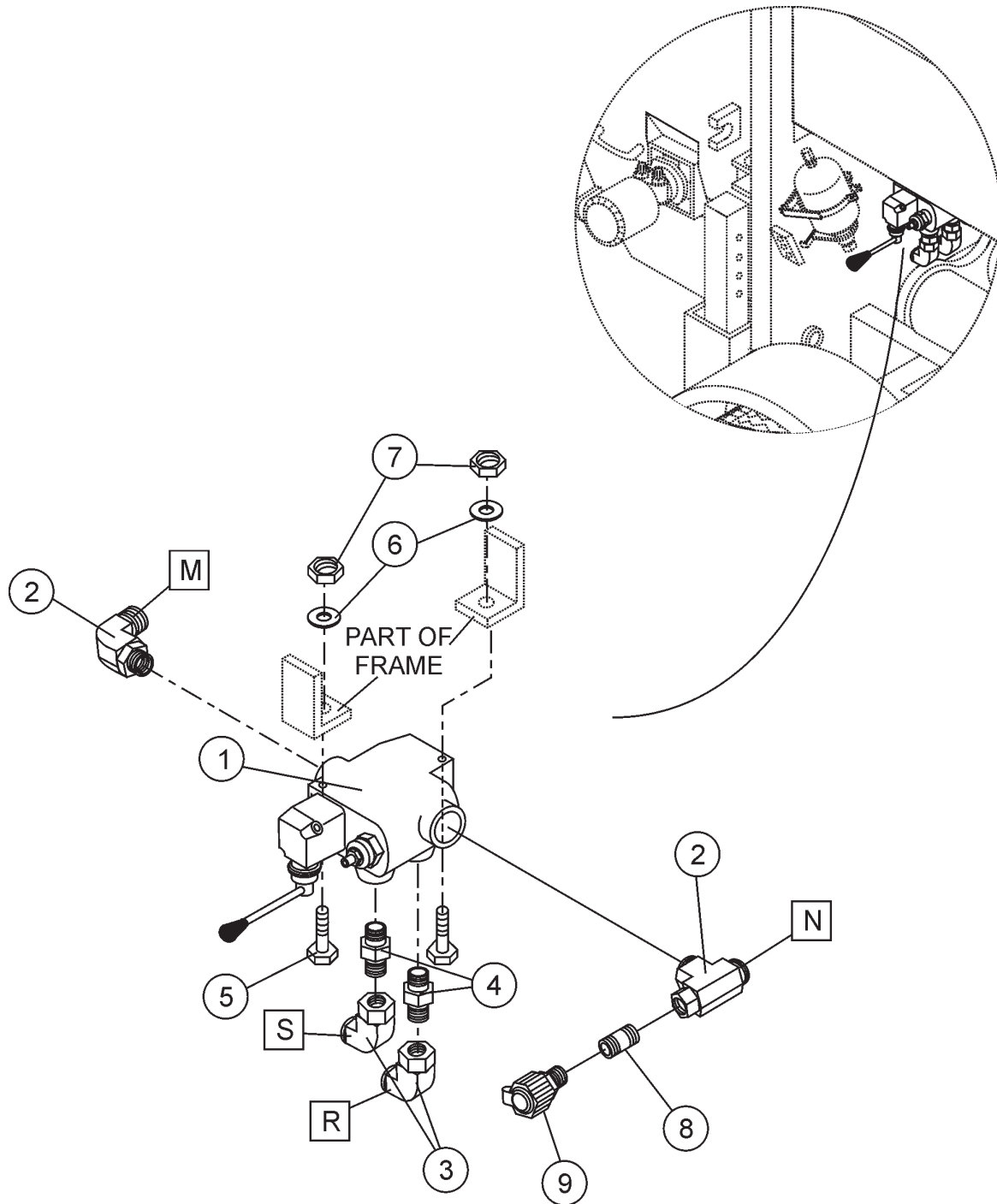

NOTES

<table border="1"><tr><td>M</td><td>N</td></tr></table>	M	N	HYDRAULIC HOSE CONNECTIONS
M	N		
<table border="1"><tr><td>R</td><td>S</td></tr></table>	R	S	SEE PARTS LIST FOR DETAILS
R	S		

LS-60TD PUMP — REMIXER CONTROL ASSY.

REMIXER CONTROL ASSY.

<u>NO.</u>	<u>PART NO.</u>	<u>PART NAME</u>	<u>QTY.</u>	<u>REMARKS</u>
1	EM25495	VALVE REMIXER W/ LEVER	1	
2	513394	ADAPTER FITTING, T	2	
3	506195	ADAPTER FITTING, 90° ELBOW	2	
4	CIP25509	ADAPTER FITTING, STRAIGHT	2	
5	CIP218	BOLT 5/16 X 2-1/2 IN.	2	
6	CIP492623	WASHER, LOCK 5/16 IN.	2	
7	CIP492553	NUT, HEX 5/16 IN.	2	
8	EM98015	COUPLING	1	
9	EM98014	TEST PORT	1	

LS-60TD PUMP — LUBRICATION PANEL

GREASE POINTS

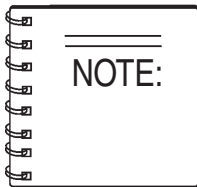
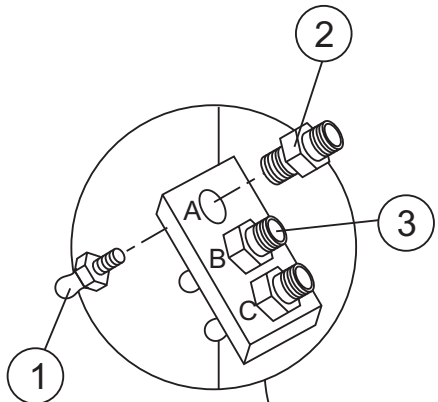

Grease daily, two or three hots of #2 multipurpose automotive grease. Over greasing any bearing will not damage the machine. **ALWAYS** grease *before and after* pump operation.

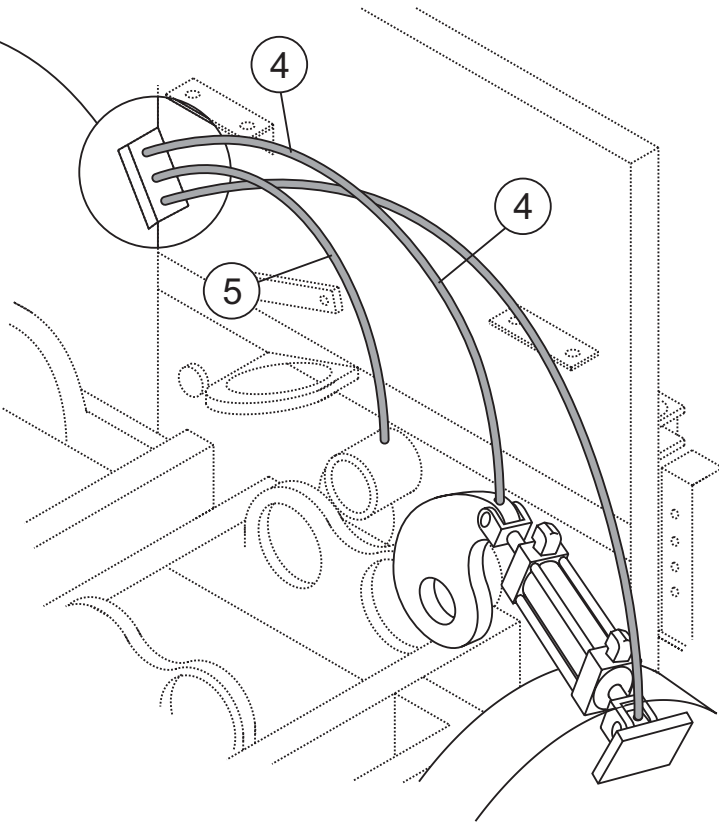

<u>POSITION</u>	<u>LOCATION</u>	<u>LENGTH OF LINES</u>
A	CLEVIS GREASE POINT	34 in. (1.1 m)
B	SWING AXLE BUSHING GREASE POINT	26 in. (.85 m)
C	PIVOT BRACKET GREASE POINT	41 in. (1.5 m)

LS-60TD PUMP — LUBRICATION PANEL

GREASE POINTS

<u>NO.</u>	<u>PART NO.</u>	<u>PART NAME</u>	<u>QTY.</u>	<u>REMARKS</u>
1	EM491701	GREASE FITTING	3	
2	EM208812	CONNECTOIR	2	
3	EM510684	CONNECTOR	3	
4	EM505516	HOSE, PLASTIC	A/R	
5	EM510487	HOSE, STEEL	A/R	

LS-60TD PUMP — ENGINE COVER ASSY.

ENGINE COVER ASSY.

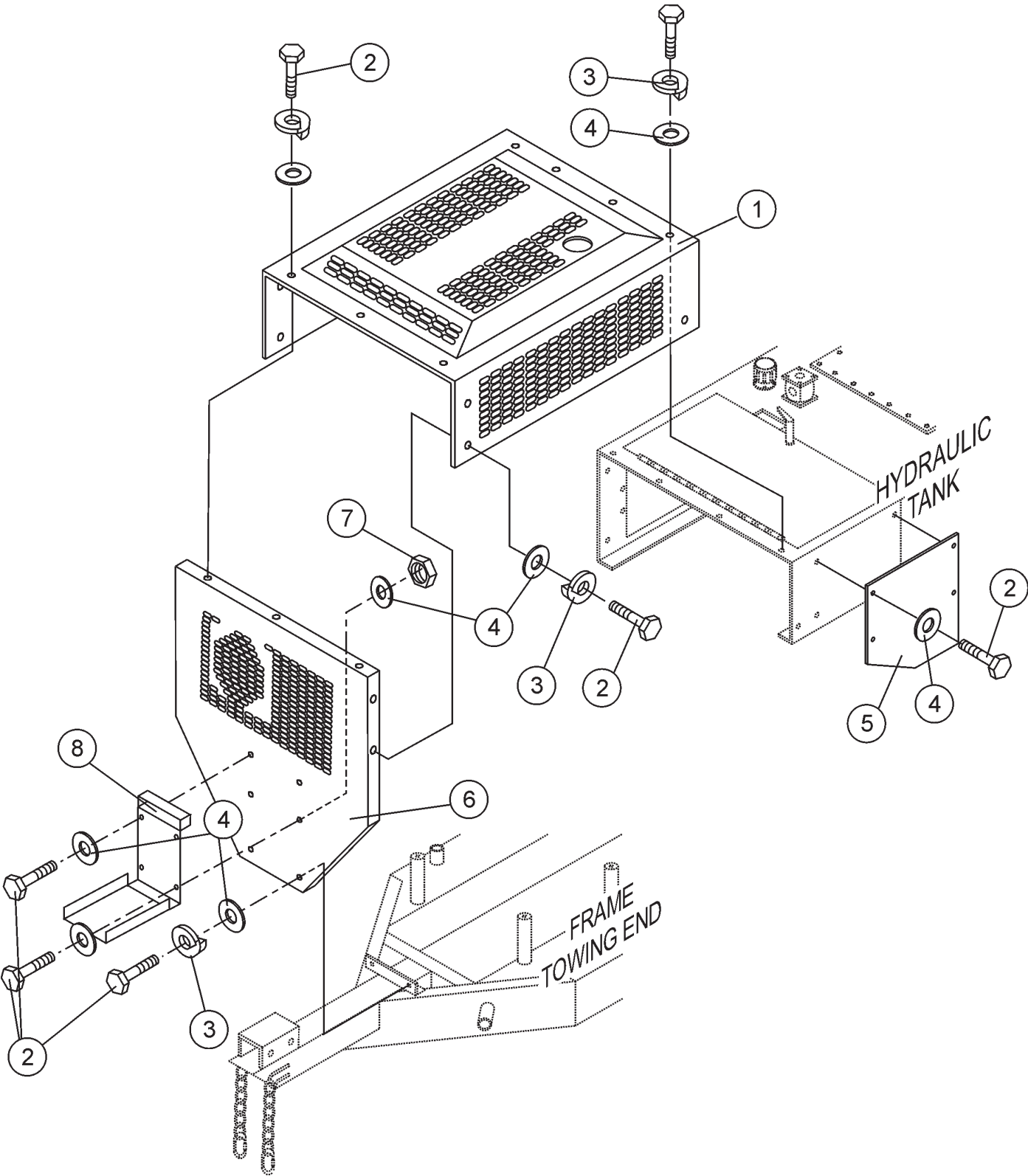

LS-60TD PUMP — ENGINE COVER ASSY.

ENGINE COVER ASSY.

<u>NO.</u>	<u>PART NO.</u>	<u>PART NAME</u>	<u>QTY.</u>	<u>REMARKS</u>
1	EM514854	COVER, TOP	1	LS-40D
1	EM514346	COVER, TOP	1	LS-40TD, LS-50TD
2	EM492356	BOLT, HEX 1/4 X 3/4 IN.	18	
3	EM492622	WASHER, LOCK 1/4 IN.	18	
4	EM492596	WASHER, FLAT 1/4 IN.	18	
5	514889	PLATE, SIDE COVER	1	
6	EM510271	COVER, FRONT ENGINE	1	
7	EM492581	NUT, HEX 1/4 IN. NC	4	
8	29057	DOCUMENT BOX	1	

LS-60TD PUMP — HYDRAULIC TANK ASSY.

HYDRAULIC TANK ASSY.

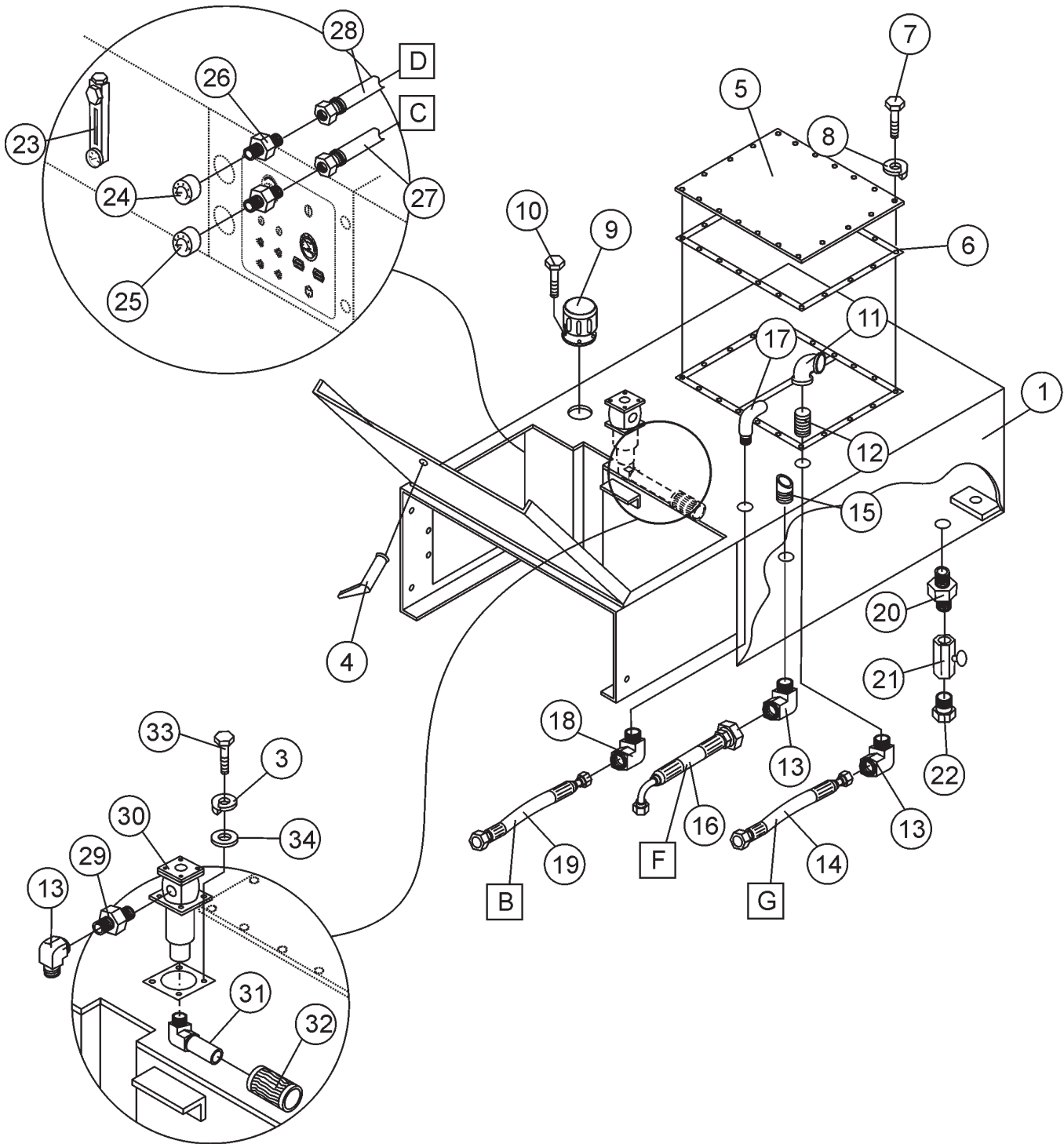

NOTES

- | | | | |
|---|---|---|----------------------------|
| D | B | G | HYDRAULIC HOSE CONNECTIONS |
| C | F | | SEE PARTS LIST FOR DETAILS |

LS-60TD PUMP — HYDRAULIC TANK ASSY.

HYDRAULIC TANK ASSY.

<u>NO.</u>	<u>PART NO.</u>	<u>PART NAME</u>	<u>QTY.</u>	<u>REMARKS</u>
1	CIP514040	HYDRAULIC TANK, LS-S	1	
3	CIP492624	LOCK, WASHER 3/8 IN.	4	
4	CIP508659	HANDLE	1	
5	CIP25119-1	TANK COVER PLATE	1	
6	EM25184	RESERVOIR GASKET	1	
7	CIP492362	BOLT 5/16 X 5/8 IN.	20	
8	CIP492623	WASHER, LOCK 5/16 IN.	20	
9	EM16477	CAP ASSEMBLY	1	
10	CIP492267	BOLT 3/16 X 5/8 IN.	6	
11	CIP491160	ELBOW 90 DEGREE	1	
12	CIP491189	ELBOW	1	
13	CIP18436	90° MALE ADAPTER 2103-16-16	3	
14	CIP514605	HOSE	1	CONNECT TO MANIFOLD PORT "T1"
15	CIP514622	FITTING 1 IN.	1	
16	CIP514597	HOSE	1	CONNECT TO SEC. HYD. PUMP, HOSE F
17	CIP491164	ELBOW, 3/4 IN.	1	
18	CIP491375	ADAPTER 2103-12-08	1	
19	CIP514598	HOSE (2000 PSI)	1	CONNECT TO MAIN HYD. PUMP, HOSE B
20	CIP509369	STRAIGHT MALE ADAPTOR , 0101-08-08	1	
21	CIP491237	VALVE 1/2 IN.	1	
22	CIP506094	CAP 1/2 IN.	1	
23	EM16478	GAUGE, LEVEL & TEMP.	1	
24	EM97066	GAUGE 3000PSI	1	
25	CIP97067	GAUGE 5000 PSI	1	
26	EM25523	ADAPTER	2	
27	509517	HOSE, 4000 PSI MAIN GAUGE	1	CONNECT TO MAIN HYD. PUMP, HOSE C
28	CIP514602	HOSE, 4000 PSI ACCUMULATOR GAUGE	1	CONNECT TO MANIFOLD PORT "GA"
29	CIP16517	STRAIGHT MALE ADAPTER 0102-24-16	1	
30	EM98112	FILTER RETURN ASSY.	1	
31	CIP16433	ELBOW 1-1/2, 11-1/2 IN. NPT	1	
32	EM16513	DEFUSER	1	
33	CIP492376	BOLT 3/8 X 1-1/4 IN.	4	
34	CIP492598	WASHER, FLAT 3/8 IN.	4	

LS-60TD PUMP — LS-60TD ENGINE ASSY.

LS-60TD ENGINE ASSY.

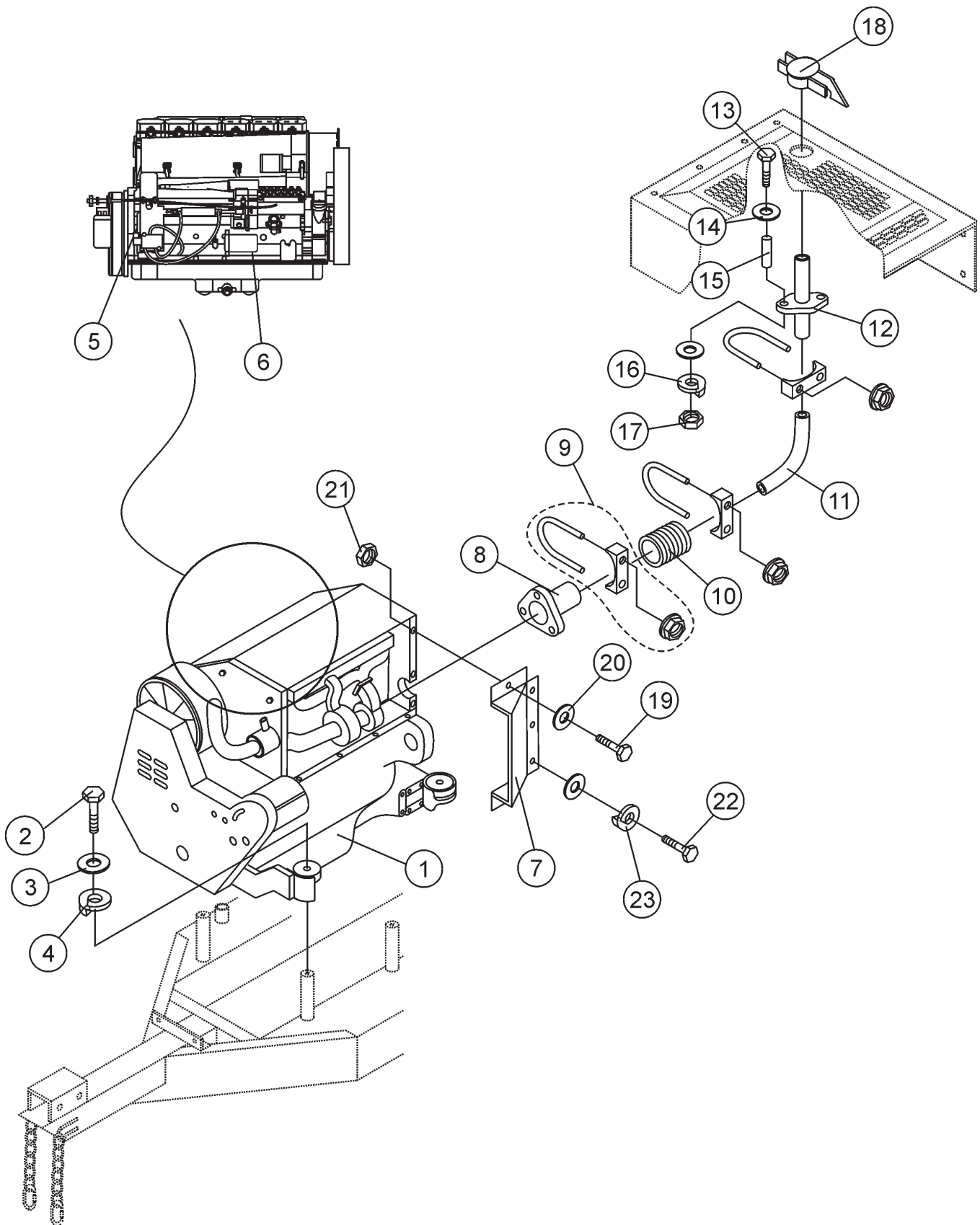

LS-60TD PUMP — LS-60TD ENGINE ASSY.

LS-60TD ENGINE ASSY.

<u>NO.</u>	<u>PART NO.</u>	<u>PART NAME</u>	<u>QTY.</u>	<u>REMARKS</u>
1	EM98197	ENGINE, DEUTZ TURBO 110 HP BF4L914	1	
2	CIP492401	BOLT 1/2 IN.X 4 FT.	4	
3	CIP492600	WASHER, FLAT 1/2 IN.	4	
4	CIP492626	WASHER, LOCK 1/2 IN.	4	
5	01174416	FILTER, OIL (ENGINE)	1	
6	01174696	FILTER, FUEL (ENGINE)	1	
7	CIP513776	DEFLECTOR	1	
8	CIP514631	FLANGE, EXHAUST	1	
9	CIP20735	U-CLAMP, EXHAUST 2-1/4 IN.	2	
10	CIP510894	FLEX TUBING	1	
11	CIP20734	TUBE, 90° EXHAUST	1	
12	CIP514633	REDUCTION TUBE, EXHAUST	1	
13	CIP492371	BOLT 5/16 NC X 3 IN. G5	2	
14	CIP492597	WASHER, FLAT 5/16 IN.	4	
15	CIP514714	SPACER, EXHAUST	2	
16	CIP492623	WASHER, LOCK 5/16 IN.	2	
17	CIP492553	HEX NUT 5/16 IN. G5	2	
18	EM510897	CAP, EXHAUST 2-1/2 IN.	1	
19	CIP492364	BOLT 5/16 X 1 IN.	2	
20	CIP492597	WASHER, FLAT 5/16 IN.	7	
22	CIP506886	BOLT M8 X 20 X 1-1/4 IN.	3	
23	CIP492623	WASHER, LOCK 5/16 IN.	4	
21	CIP492582	NUT, HEX 5/16 IN.	3	

LS-60TD PUMP — LS-60TD ENGINE AIR FILTER ASSY.

LS-60TD ENGINE AIR FILTER ASSY.

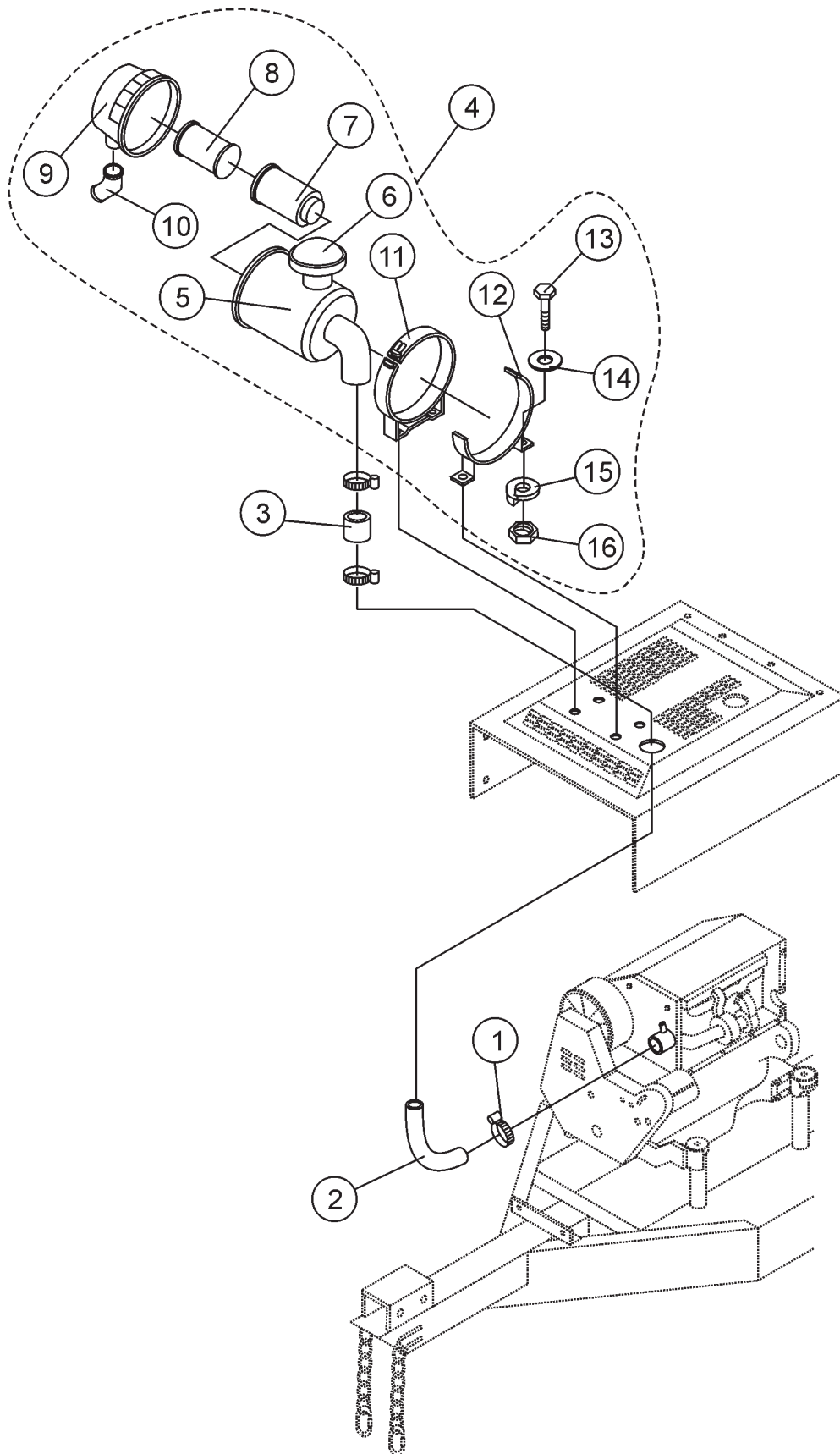

LS-60TD PUMP — LS-60TD ENGINE AIR FILTER ASSY.

LS-60TD ENGINE AIR FILTER ASSY.

<u>NO.</u>	<u>PART NO.</u>	<u>PART NAME</u>	<u>QTY.</u>	<u>REMARKS</u>
1	CIP493108	CLAMP	3	
2	CIP513227	AIR FILTER HOSE 3-1/2 IN.	.5	
3	CIP514367	TUBE AIR FILTER UNION	1	
4	22002183	AIR CLEANER ASSY.	1	INCLUDES ITEMS W/*
5*	CIP98093	FILTER, AIR	1	
6*	EM98207	CAP, RAIN	1	
7*	EM98093P	ELEMENT, PRIMARY	1	
8*	EM98093S	ELEMENT, SECONDARY	1	
9*	TBD	HOOD, AIR CLEANER	1	
10*	TBD	DUST EJECTOR	1	
11*		ADJUSTABLE SUPPORT, AIR FILTER	1	NOT SOLD SEPERATELY
12*		SUPPORT, AIR FILTER	1	NOT SOLD SEPERATELY
13*	CIP492357	BOLT, HEX HEAD 1/4 X 1 IN.	4	
14*	CIP492596	WASHER, FLAT 1/4 IN.	8	
15*	TBD	WASHER, LOCK 1/4 IN.	4	
16*	CIP492581	NUT, HEX 1/4 IN.	4	

LS-60TD PUMP — THROTTLE ASSY.

THROTTLE ASSY.

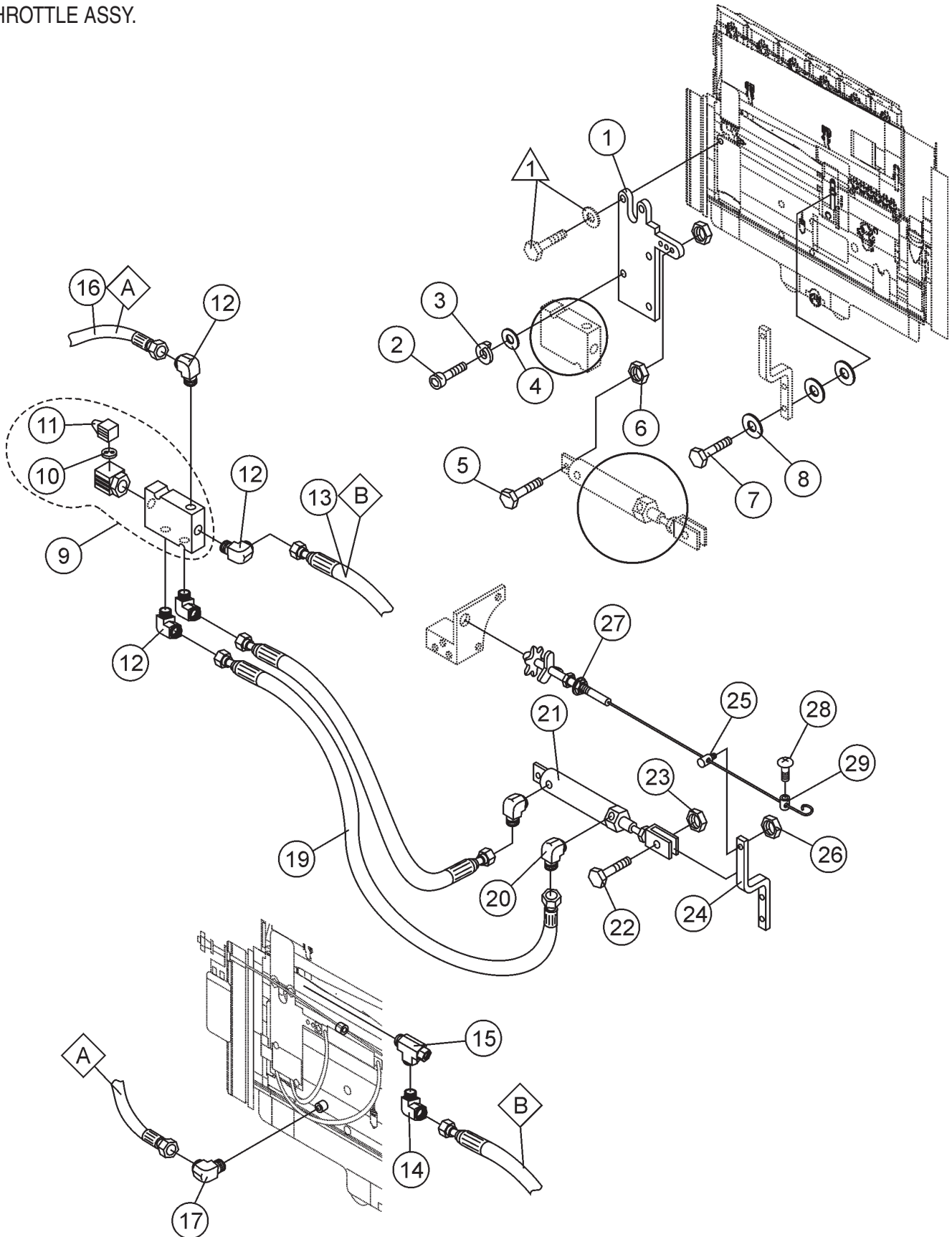

LS-60TD PUMP — THROTTLE ASSY.

THROTTLE ASSY.



<u>NO.</u>	<u>PART NO.</u>	<u>PART NAME</u>	<u>QTY.</u>	<u>REMARKS</u>
1	CIP512837	SUPPORT BASE, ACCELERATOR	1	
2	CIP492358	BOLT 1/4 X 1-1/4	2	
3	CIP492622	WASHER 1/4 IN.	2	
4	CIP492596	LOCK WASHER 1/4 IN.	2	
5	CIP512185	BOLT 1/4 X 1-3/4 IN.	1	
6	CIP492581	HEX NUT 1/4 IN.	2	
7	CIP506599	BOLT M6 X 15	2	
8	CIP492622	WASHER, FLAT 1/4 IN.	4	
9	EM98168	THROTTLE BLOCK COUPLING	1	INCLUDES ITEMS W/*
10*	EM98167	SEAL CONNECTOR	1	
11*	EM98166	CONNECTOR, DIN PG9	1	
12	EM25429	ELBOW ADAPTER 90° MALE	4	
13	EM509937	HOSE, HYDRAULIC COMPENSATOR	1	
14	CIP25577	ELBOW ADAPTER IN.T IN.	1	
15	CIP50449	ELBOW ADAPTER 90 DEG. MALE	2	
19	CIP509366	HOSE 13.75 IN. LONG	2	
20	CIP50449	ELBOW ADAPTER 90° MALE	2	
21	CIPCC700	HYDRAULIC CYLINDER	1	
22	CIP492357	BOLT 1/4 IN. X 1 IN.	1	
23	CIP492581	NUT 1/4 IN.	1	
24	CIP512838	BRACKET, ACCELERATOR	1	
25	CIP513213	THROTTLE CABLE GUIDE	1	
26	CIP2101428	HEX NUT 1/4-20 IN.	1	
27	CIP510229	CABLE CONTROL ACCELERATOR	1	
28	CIP491089	BOLT 8 X 1/4 IN.	1	
29	EM501102	SLEEVE, ACCELERATOR	1	

LS-60TD PUMP — WATER SEPERATOR ASSY.

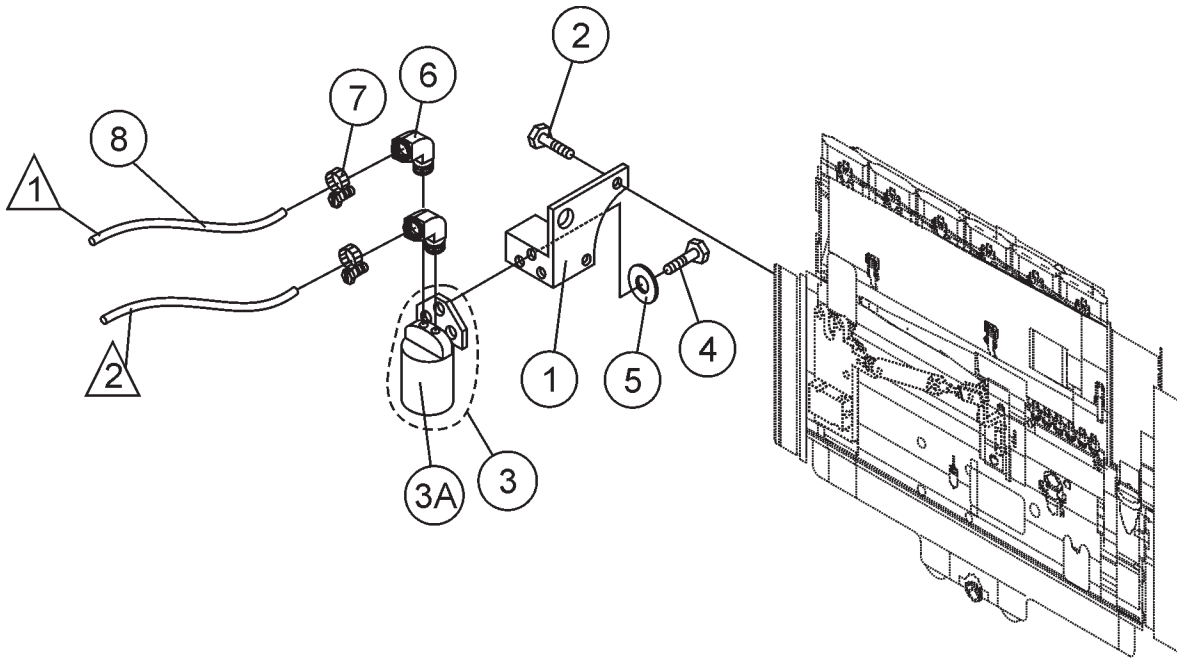
WATER SEPERATOR ASSY.



NOTES

-  CONNECT TO FUEL FILTER
FUEL TANK ASSY., ITEM 11
-  CONNECT TO FUEL RETURN HOSE
FUEL TANK ASSY., ITEM 8

LS-60TD PUMP — WATER SEPERATOR ASSY.

WATER SEPERATOR ASSY.

<u>NO.</u>	<u>PART NO.</u>	<u>PART NAME</u>	<u>QTY.</u>	<u>REMARKS</u>
1	CIP509449	BRACKET, WATER SEPERATOR	1	
2	EM492356	BOLT	2	
3	EM16747	WATER SEPERATOR ASSEMBLY	1	
3A	P53712	CARTRIDGE, WATER SEPERATOR	1	
4	EM492356	BOLT 5/16 X 1 IN.	3	
5	CIP492582	HEX NUT 5/16 IN.	3	
6	CIP514559	ELBOW ADAPTER 90° MALE	2	
7	EM506208	CLAMP, HOSE	2	
8	CIP514536	HOSE 5/16 IN.	TBD	

LS-60TD PUMP — HYDRAULIC PUMP ASSY.

HYDRAULIC PUMP ASSY.

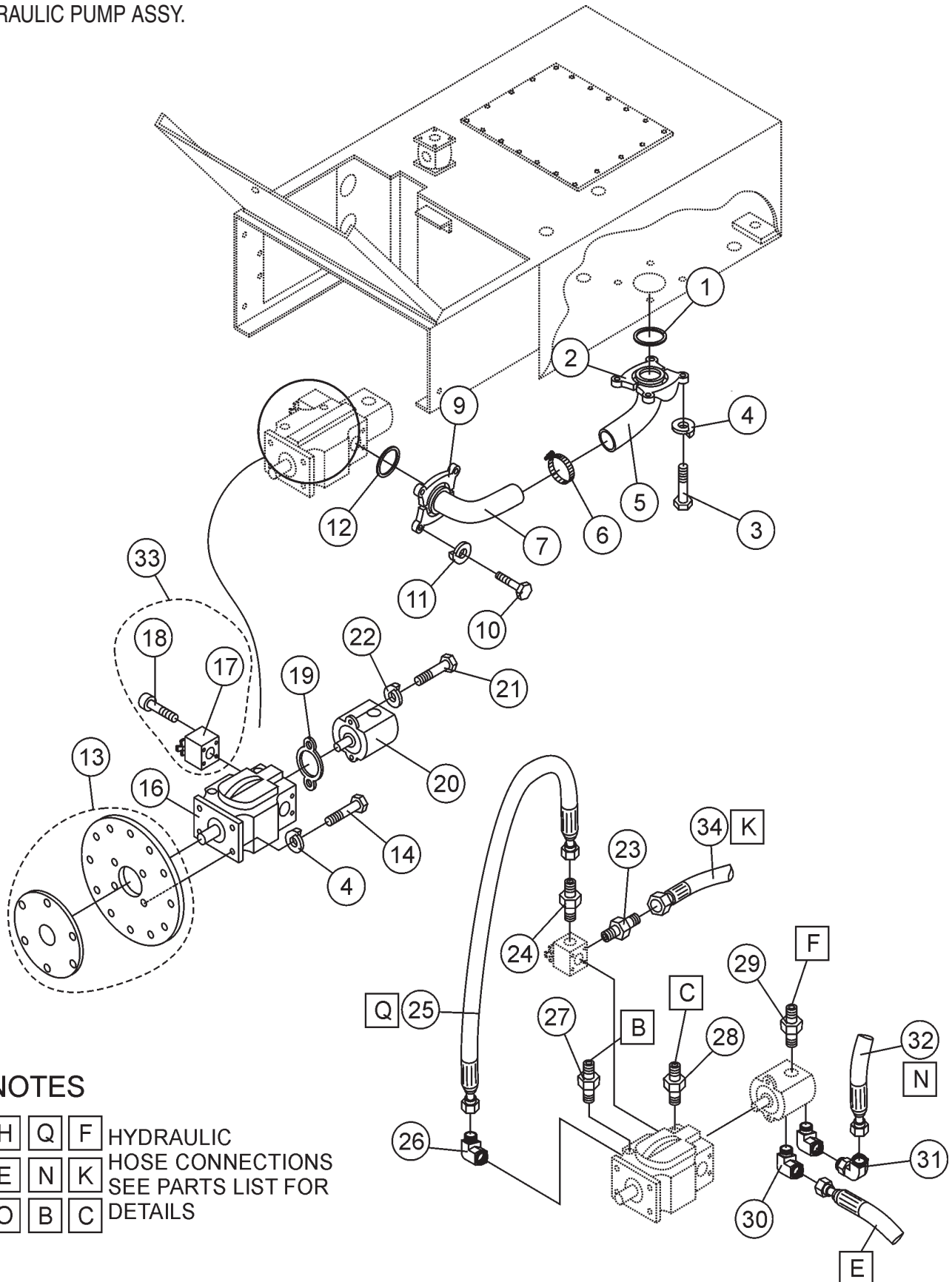

NOTES

- | | | | |
|---|---|---|--------------------|
| H | Q | F | HYDRAULIC |
| E | N | K | HOSE CONNECTIONS |
| O | B | C | SEE PARTS LIST FOR |
| | | | DETAILS |

LS-60TD PUMP — HYDRAULIC PUMP ASSY.

HYDRAULIC PUMP ASSY.

<u>NO.</u>	<u>PART NO.</u>	<u>PART NAME</u>	<u>QTY.</u>	<u>REMARKS</u>
1*	TBD	O-RING	1	
2	CIP514719	FLANGE, SUCTION PIPE	2	INCLUDES ITEMS W/*
3	CIP492455	BOLT 1/2 X 1-1/2 IN.	4	
4	CIP492626	WASHER, LOCK 1/2 IN.	8	
5	CIP514720	SUCTION PIPE ADAPTER, 40 SPECIAL	2	
6	EM26473	CLAMP TYPE 'J' 3 IN.	4	
7	CIP514712	HOSE, SUCTION 2 IN.	1	
9	CIP514628	FLANGE, SUCTION PIPE	1	INCLUDES ITEMS W/%
12%	TBD	O-RING	1	
13	EM98176	COUPLER, ENGINE ASSY.	1	
14	CIP510902	BOLT 1/2 X 1-1/2 IN.	4	
16	EM98154	PUMP, MAIN 105CC	1	
17	EM98209	VALVE, CARTRIDGE	1	
18	CIP506953	BOLT 7/16 X 3 IN.	4	
19	EM16190	GASKET	1	
20	EM98107	PUMP, SECONDARY	1	
21	CIP492375	BOLT 3/8 X 1 IN.	2	
22	CIP492624	WASHER, LOCK 3/8 IN.	2	
23	CIP509425	STRAIGHT ADAPTER	1	
24	EM25511	ADAPTER	1	
25	CIP514599	HOSE 4000 PSI	1	
26	EM25506	ELBOW ADAPTER	1	
27	EM16525	STRAIGHT ADAPTER	1	
29	EM25498	STRAIGHT ADAPTER	1	
30	EM16524	ELBOW ADAPTER 90° MALE	2	
31	CIP506195	ELBOW ADAPTER 90° FEMALE	1	
32	EM514601	HOSE 2000 PSI	1	
33	EM98165	FLOW CONTROL ASSY.	1	
34	CIP514614	HOSE, 4000 PSI	1	CONNECT TO MANIFOLD PORT P2, HOSE K

LS-60TD PUMP — MANIFOLD ASSY.

MANIFOLD ASSY.

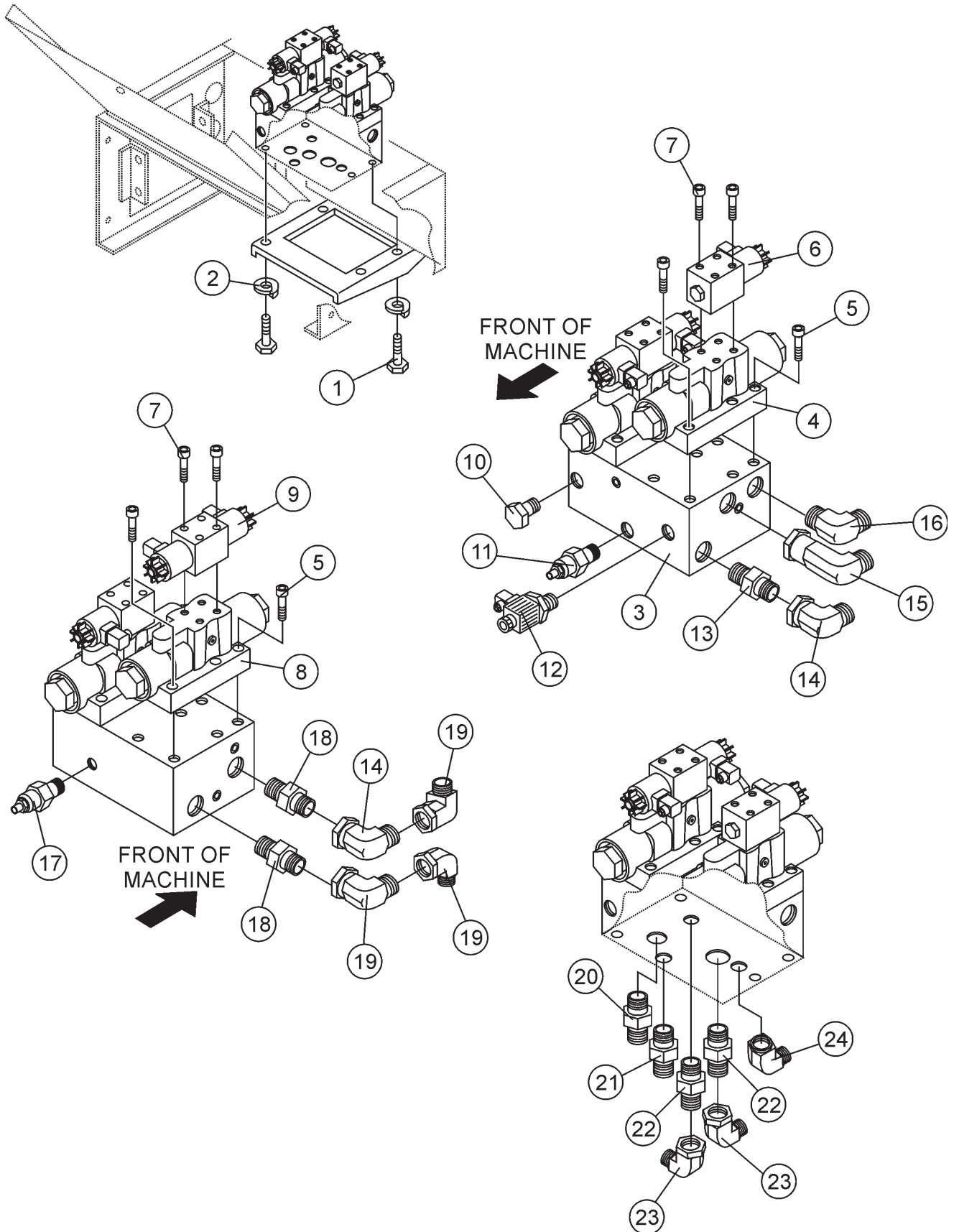

LS-60TD PUMP — MANIFOLD ASSY.

MANIFOLD ASSY.

<u>NO.</u>	<u>PART NO.</u>	<u>PART NAME</u>	<u>QTY.</u>	<u>REMARKS</u>
1	CIP492393	BOLT 1/2 X 1-1/4 IN.	4	
2	CIP492626	WASHER, LOCK 1/2 IN.	4	
3	EM98109	MANIFOLD ASSY	1	
4	EM98221	CYCLING VALVE, SWING	1	
5	TBD	BOLT, ALLEN HEAD	12	
6	EM98223	PILOT VALVE, SHUTTLE	1	
7	TBD	BOLT, ALLEN HEAD	8	
8	EM98220	CYCLING VALVE, MAIN	1	
9	EM98222	PILOT VALVE, MAIN CYLINDER	1	
10	TBD	PLUG	1	
11	EM98224	MAIN RELIEF VALVE	1	
12	EM98228	COIL, 12VDC ACCUMULATOR	1	
13	CIP25498	ADAPTER	1	
14	CIP509401	ADAPTER	2	
15	CIP514488	ADAPTER	1	
16	CIP25459	ADAPTER	1	
17	EM98226	UNLOADING RELIEF VALVE, SHUTTLE	1	
18	CIP514231	ADAPTER	2	
19	CIP14489	ADAPTER	3	
20	CIP491372	ADAPTER	1	
21	CIP506193	ADAPTER	1	
22	CIP25462	ADAPTER	2	
23	CIP509353	ADAPTER	2	
24	EM25429	ADAPTER	1	

LS-60TD PUMP — CONTROL BOX ASSY.

CONTROL BOX ASSY.

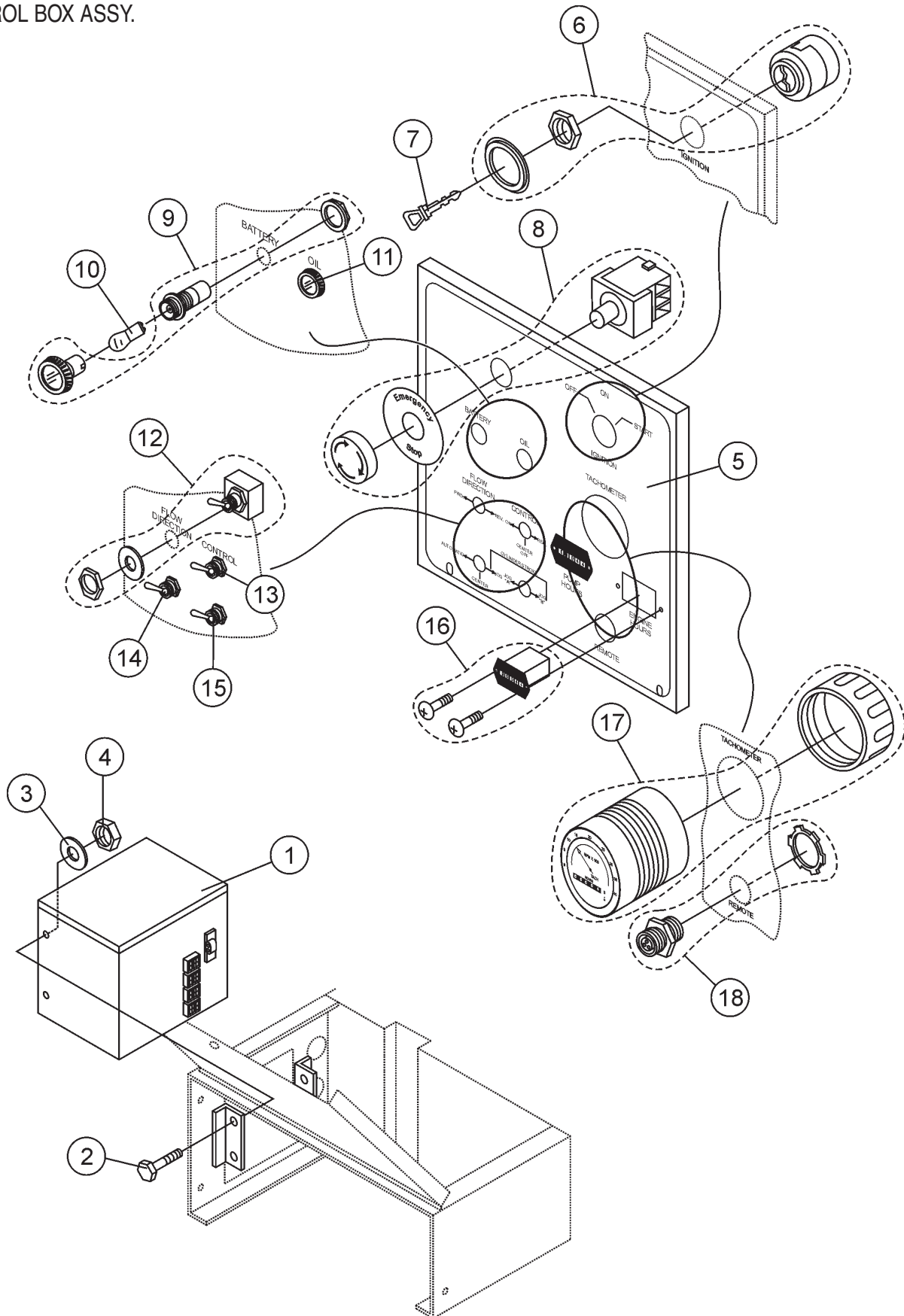

LS-60TD PUMP — CONTROL BOX ASSY.

CONTROL BOX ASSY.

<u>NO.</u>	<u>PART NO.</u>	<u>PART NAME</u>	<u>QTY.</u>	<u>REMARKS</u>
1	EM9812560	CONTROL BOX ASSY	1	
2	CIP492364	BOLT 5/16 X 1 IN.	4	
3	CIP492597	WASHER, FLAT 5/16 IN.	4	
4	CIP492582	NUT 5/16 IN.	4	
5	EM98171	OVERLAY, CONTROL PANEL	1	
6	EM98206	IGNITION SWITCH ASSY.	1	
7	EM98206K	KEY, IGNITION	1	
8	EM98208	EMERGENCY STOP SWITCH ASSY.	1	
9	01180384	BATTERY LIGHT ASSY.	1	
10	51908	BULB, LIGHT	1	
11	01180382	OIL LIGHT ASSY.	1	
12	EM98120	FLOW DIRECTION SWITCH ASSY.	1	
13	EM98119	MAIN CONTROL SWITCH ASSY.	1	
14	EM98121	AUTO/JOG SWITCH ASSY.	1	
15	EM98122	JOG A/B SWITCH ASSY.	1	
16	EM97062	HOUR METER ASSY.	2	
17	EM98124	TACHOMETER ASSY.	1	
18	EM97068	RECEPTACLE, REMOTE	1	

LS-60TD PUMP — CONTROL BOX HARNESSSES ASSY.

CONTROL BOX HARNESSSES ASSY.

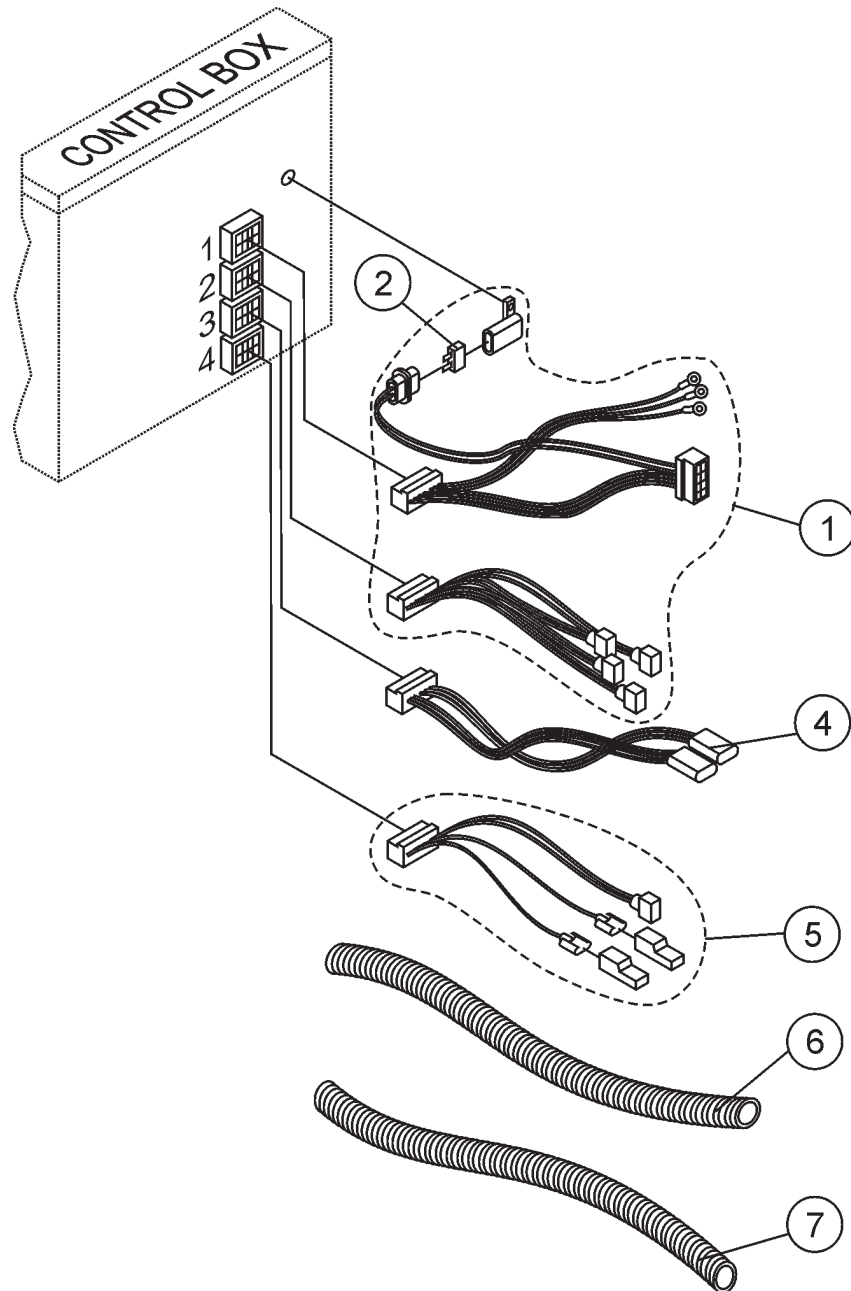

LS-60TD PUMP — CONTROL BOX HARNESSSES ASSY.

CONTROL BOX HARNESSSES ASSY.

<u>NO.</u>	<u>PART NO.</u>	<u>PART NAME</u>	<u>QTY.</u>	<u>REMARKS</u>
1	EM514639	WIRE HARNESS 1	1	
2	344102000	FUSE, 30 AMP	1	
4	CIP514637	WIRE HARNESS 3	1	
5	CIP514638	WIRE HARNESS 4	1	
6	CIP509588	POLY FLEX TUBE 1/2 IN. BLACK	AR	
7	CIP16716	CONDUCTIVE DIVIDER 3/8 IN.	AR	

LS-60TD PUMP — REMOTE CONTROL CABLE ASSY.

REMOTE CONTROL CABLE ASSY.

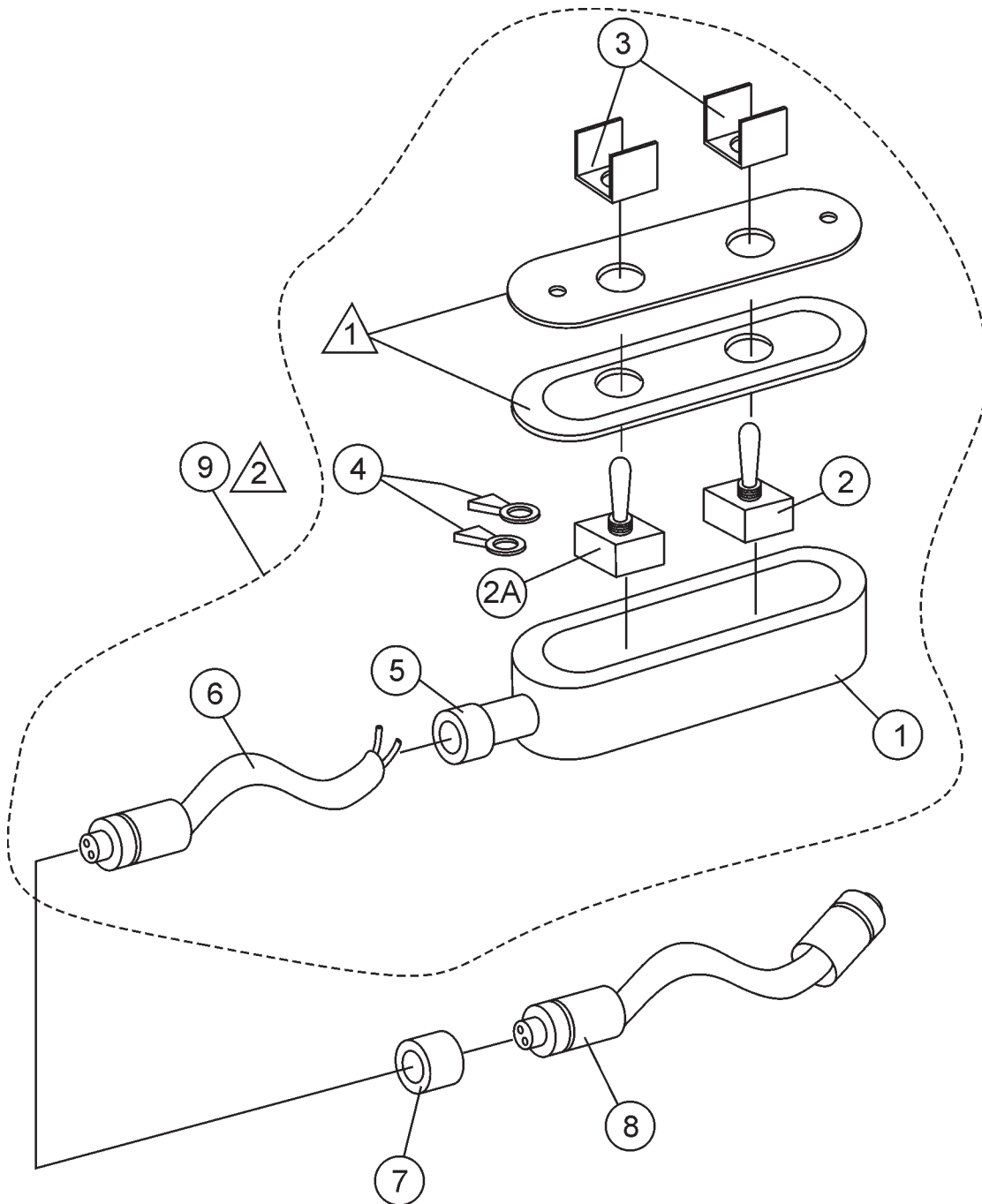

NOTES:

- △ 1 INCLUDED WITH ITEM 1.
- △ 2 COMPLETE CORD ASSY. INCLUDES ITEMS WITHIN DASHED LINE.

LS-60TD PUMP — REMOTE CONTROL CABLE ASSY.

REMOTE CONTROL CABLE ASSY.

<u>NO.</u>	<u>PART NO.</u>	<u>PART NAME</u>	<u>QTY.</u>	<u>REMARKS</u>
1*	EM16753	JUNCTION BOX	1	
2*	EM16754	SWITCH	1	
2A	EM97075	SWITCH	1	
3*	EM491897	CONNECTOR, RING 3/16 IN.	4	
4*	EM16756	GUARD SWITCH - ALUMINUM	2	
5*	EM26791	SEAL, GRIP CORD	1	
6*	EM26790	CORD, MX P/E 25 FT.	1	
7	EM26793	ADAPTER, CORD GRIP 1/2 IN.	1	
8	EM97065	ADAPTER, CORD 100 FT.	1	
9	EM97099	COMPLETE CORD ASSY 25 FT	1	INCLUDES ITEMS W/*

PAYMENT TERMS

Terms of payment for parts are net 10 days.

FREIGHT POLICY

All parts orders will be shipped collect or prepaid with the charges added to the invoice. All shipments are F.O.B. point of origin. Multiquip's responsibility ceases when a signed manifest has been obtained from the carrier, and any claim for shortage or damage must be settled between the consignee and the carrier.

MINIMUM ORDER

The minimum charge for orders from Multiquip is \$15.00 net. Customers will be asked for instructions regarding handling of orders not meeting this requirement.

RETURNED GOODS POLICY

Return shipments will be accepted and credit will be allowed, subject to the following provisions:

1. A Returned Material Authorization must be approved by Multiquip prior to shipment.
2. To obtain a Return Material Authorization, a list must be provided to Multiquip Parts Sales that defines item numbers, quantities, and descriptions of the items to be returned.
 - a. The parts numbers and descriptions must match the current parts price list.
 - b. The list must be typed or computer generated.
 - c. The list must state the reason(s) for the return.
 - d. The list must reference the sales order(s) or invoice(s) under which the items were originally purchased.
 - e. The list must include the name and phone number of the person requesting the RMA.
3. A copy of the Return Material Authorization must accompany the return shipment.
4. Freight is at the sender's expense. All parts must be returned freight prepaid to Multiquip's designated receiving point.

5. Parts must be in new and resalable condition, in the original Multiquip package (if any), and with Multiquip part numbers clearly marked.
6. The following items are not returnable:
 - a. Obsolete parts. (If an item is in the price book and shows as being replaced by another item, it is obsolete.)
 - b. Any parts with a limited shelf life (such as gaskets, seals, "O" rings, and other rubber parts) that were purchased more than six months prior to the return date.
 - c. Any line item with an extended dealer net price of less than \$5.00.
 - d. Special order items.
 - e. Electrical components.
 - f. Paint, chemicals, and lubricants.
 - g. Decals and paper products.
 - h. Items purchased in kits.
7. The sender will be notified of any material received that is not acceptable.
8. Such material will be held for five working days from notification, pending instructions. If a reply is not received within five days, the material will be returned to the sender at his expense.
9. Credit on returned parts will be issued at dealer net price at time of the original purchase, less a 15% restocking charge.
10. In cases where an item is accepted, for which the original purchase document can not be determined, the price will be based on the list price that was effective twelve months prior to the RMA date.
11. Credit issued will be applied to future purchases only.

PRICING AND REBATES

Prices are subject to change without prior notice. Price changes are effective on a specific date and all orders received on or after that date will be billed at the revised price. Rebates for price declines and added charges for price increases will not be made for stock on hand at the time of any price change.

Multiquip reserves the right to quote and sell direct to Government agencies, and to Original Equipment Manufacturer accounts who use our products as integral parts of their own products.

SPECIAL EXPEDITING SERVICE

A \$35.00 surcharge will be added to the invoice for special handling including bus shipments, insured parcel post or in cases where Multiquip must personally deliver the parts to the carrier.

LIMITATIONS OF SELLER'S LIABILITY

Multiquip shall not be liable hereunder for damages in excess of the purchase price of the item with respect to which damages are claimed, and in no event shall Multiquip be liable for loss of profit or good will or for any other special, consequential or incidental damages.

LIMITATION OF WARRANTIES

No warranties, express or implied, are made in connection with the sale of parts or trade accessories nor as to any engine not manufactured by Multiquip. Such warranties made in connection with the sale of new, complete units are made exclusively by a statement of warranty packaged with such units, and Multiquip neither assumes nor authorizes any person to assume for it any other obligation or liability whatever in connection with the sale of its products. Apart from such written statement of warranty, there are no warranties, express, implied or statutory, which extend beyond the description of the products on the face hereof.

Mechanical Drive Models

MAYCO PUMP, hereinafter referred to as “Manufacturer”, warrants each new Mayco Pump sold by the manufacturer to be free from defects in material and workmanship, under normal use and service, for a period of one year after the date of delivery to the original retail purchaser. Manufacturer will, at its option, replace or repair at a point designated by the Manufacturer any part or parts which shall appear to the satisfaction of the Manufacturer upon inspection at such point to have been defective in material or workmanship. This warranty does not obligate the Manufacturer to bear any transportation charges or labor charges in connection with the replacement or repair the of the defective parts.

This warranty does not apply to any pump if attempts have been made to pump concrete materials which have separated, to any pump which has been repaired with other than Genuine Mayco Parts, nor to any pump which has been altered, repaired or used in such manner as to adversely affect its performance, nor to normal service or maintenance or where blockages have developed within the pump manifold or placing line or which has been operated in any other manner not recommended by the Manufacturer. Due to the abrasive nature of concrete, Mayco does not cover natural component wear.

THIS WARRANTY AND MANUFACTURER’S OBLIGATION HEREUNDER, IS IN LIEU OF ALL OTHER WARRANTIES, EXPRESS, IMPLIED OR STATUTORY AND ALL OTHER OBLIGATIONS OR LIABILITIES INCLUDING SPECIAL OR CONSEQUENTIAL DAMAGES OR CONTINGENT LIABILITIES ARISING OUT OF THE FAILURE OF ANY

PUMP OR PART TO OPERATE PROPERLY, INCLUDING ANY WARRANTIES OF MERCHANTABILITY OR FITNESS FOR A PARTICULAR PURPOSE.

Hydraulic Drive Models

MAYCO PUMP, hereinafter referred to as “Manufacturer”, warrants each new Mayco Pump sold by the manufacturer to be free from defects in material and workmanship, under normal use and service, for a period of one year or 2000 hours after the date of delivery to the original retail purchaser. The Manufacturer will, at its option, replace or repair at a point designated by Manufacturer any part or parts which shall appear to the satisfaction of Manufacturer upon inspection at such point to have been defective in material or workmanship. This warranty does not obligate Manufacturer to bear any transportation charges or labor charges in connection with the replacement or repair of the defective parts.

This warranty does not apply to any pump if attempts have been made to pump concrete materials which have separated, to any pump which has been repaired with other than Genuine Mayco Parts, nor to any pump which has been altered, repaired or used in such manner as to adversely affect it’s performance, nor to normal service or maintenance or where blockages have developed within the pump manifold or placing line or which has been operated in any other manner not recommended by the Manufacturer. Due to the abrasive nature of concrete, Mayco does not cover natural component wear.

THIS WARRANTY AND MANUFACTURER’S OBLIGATION HEREUNDER, IS IN LIEU OF ALL OTHER WARRANTIES, EXPRESS, IMPLIED OR STATUTORY AND ALL OTHER OBLIGATIONS OR LIABILITIES INCLUDING SPECIAL OR CONSEQUENTIAL DAMAGES OR CONTINGENT LIABILITIES ARISING OUT OF THE FAILURE OF ANY PUMP OR PART TO OPERATE PROPERLY, INCLUDING ANY WARRANTIES OF MERCHANTABILITY OR FITNESS FOR A PARTICULAR PURPOSE.

OPERATION AND PARTS MANUAL

HERE'S HOW TO GET HELP

PLEASE HAVE THE MODEL AND SERIAL
NUMBER *ON-HAND* WHEN CALLING

MULTIQUIP CORPORATE OFFICE

18910 Wilmington Ave.
Carson, CA 90746
Email: mq@multiquip.com
Internet: www.multiquip.com

800-421-1244
FAX: 310-537-3927

PARTS DEPARTMENT

800-427-1244
310-537-3700

FAX: 800-672-7877
FAX: 310-637-3284

MAYCO PARTS

800-306-2926
310-537-3700

FAX: 800-672-7877
FAX: 310-637-3284

SERVICE DEPARTMENT

800-421-1244
310-537-3700

FAX: 310-537-4259

TECHNICAL ASSISTANCE

800-478-1244

FAX: 310-631-5032

WARRANTY DEPARTMENT

800-421-1244, EXT. 279
310-537-3700, EXT. 279

FAX: 310-537-1173

Your Local Dealer is:



MULTIQUIP INC.

18910 WILMINGTON AVE.
CARSON, CALIFORNIA 90746
800-421-1244 • 310-537-3700
FAX: 310-537-3927
E-mail: mq@multiquip.com
Internet: multiquip.com