

PARTS AND OPERATION MANUAL

MULTIQUIP MODULAR LIGHT TOWER (MLT) USED WITH THE FOLLOWING GENERATORS/WELDERS: DA7000SS, KD-1800, KD-6 AND SDW-225

© COPYRIGHT 2003, MULTIQUIP INC.

MODEL # _____

SERIAL # _____

Revision #3 (06/26/06)



MULTIQUIP INC.

18910 WILMINGTON AVE.
CARSON, CALIFORNIA 90746
310-537-3700
800-421-1244
FAX: 310-537-3927

PARTS DEPARTMENT:

800-427-1244
FAX: 800-672-7877
SERVICE DEPARTMENT/TECHNICAL ASSISTANCE:
800-478-1244
FAX: 310-631-5032

E-mail: mq@multiquip.com • www.multiquip.com

Atlanta • Boise • Dallas • Houston • Newark
Montreal, Canada • Manchester, UK
Rio De Janeiro, Brazil • Guadalajara, Mexico

P/N 29210



WARNING



CALIFORNIA — Proposition 65 Warning

Diesel engine exhaust and some of its constituents are known to the State of California to cause cancer, birth defects and other reproductive harm.

HERE'S HOW TO GET HELP

*PLEASE HAVE THE MODEL AND SERIAL NUMBER
ON-HAND WHEN CALLING*

PARTS DEPARTMENT

800-427-1244 or 310-537-3700

FAX: 800-672-7877 or 310-637-3284

SERVICE DEPARTMENT/TECHNICAL ASSISTANCE

800-478-1244 or 310-537-3700

FAX: 310- 537-4259

WARRANTY DEPARTMENT

888-661-4279, or 310-661-4279

FAX: 310- 537-1173

MAIN

800-421-1244 or 310-537-3700

FAX: 310-537-3927

MQ Whiteman Modular Light Tower (MLT)

Here's How To Get Help	3
Table Of Contents	4
Parts Ordering Procedures	5
Safety Message Alert Symbols	6-7
Rules For Safe Operation	8-9
Operation and Safety Decals	10-11
Specifications	12
General Information	13
Dimensions	14-15
Components	16
Floodlight Footcandle Plot	17-19
Towing Guidelines	20-21
Trailer Safety Guidelines	22-28
Trailer Wiring Diagram	29
Hydraulic Brake Troubleshooting	30
Electric Brake Troubleshooting	31
T-Bar Installation	32
Tower Mast Pre-Setup	33
Engine Pre-Setup	34
Operation	35
Maintenance	36
Preparation For Long Term Storage	37
MLT Troubleshooting	38-40
Schematic Diagram	41
Ballast Compartment Wiring Diagram	42
Electric Fuel Switch Wiring Diagram	43
Explanation Of Code In Remarks Column	44
Spare Parts List	45

COMPONENT DRAWINGS

Name Plate and Decals	46-47
Mast Assembly	48-49
Winch Assembly	50-51
Floodlight Mounting Assembly	52-53
Light Fixture Assembly (Early)	54-55
Light Fixture Assembly (Current)	56-57
Trailer Assembly	58-59
Axle Assembly	60-61
Fuel Tank Assembly	62-63
Optional Electric Fuel Switch Assembly	64-65
Support Stands Assembly	66-67
Generator/Welder Trailer Mounting Assembly ...	68-69
Coil Cord Assembly	70-71
Power Cable Assembly	72-73
Ballast Compartment Cover Assembly	74-75
Ballast Compartment Assembly	76-77

Terms and Conditions Of Sale — Parts	78
--	----

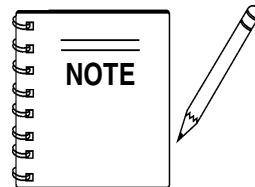

Specification and part number are subject to change without notice.

www.multiquip.com

**Ordering parts has never been easier!
Choose from three easy options:**



Order via Internet (Dealers Only):

Order parts on-line using Multiquip's SmartEquip website!

- View Parts Diagrams
- Order Parts
- Print Specification Information



If you have an MQ Account, to obtain a Username and Password, E-mail us at: parts@multiquip.com.

To obtain an MQ Account, contact your District Sales Manager for more information.

Goto www.multiquip.com and click on **Order Parts** to log in and save!

Use the **internet** and qualify for a **5% Discount** on *Standard orders* for all orders which include complete part numbers.*

Note: Discounts Are Subject To Change



Order via Fax (Dealers Only):

All customers are welcome to order parts via Fax.

Domestic (US) Customers dial:
1-800-6-PARTS-7 (800-672-7877)

Fax your order in and qualify for a **3% Discount** on *Standard orders* for all orders which include complete part numbers.*

Note: Discounts Are Subject To Change



Order via Phone: Domestic (US) Dealers Call:
1-800-427-1244

Non-Dealer Customers:

Contact your local Multiquip Dealer for parts or call 800-427-1244 for help in locating a dealer near you.



International Customers should contact their local Multiquip Representatives for Parts Ordering information.

When ordering parts, please supply:

- | | |
|--|--|
| <ul style="list-style-type: none"> <input type="checkbox"/> Dealer Account Number <input type="checkbox"/> Dealer Name and Address <input type="checkbox"/> Shipping Address (if different than billing address) <input type="checkbox"/> Return Fax Number <input type="checkbox"/> Applicable Model Number <input type="checkbox"/> Quantity, Part Number and Description of Each Part | <ul style="list-style-type: none"> <input type="checkbox"/> Specify Preferred Method of Shipment: <ul style="list-style-type: none"> <input checked="" type="checkbox"/> Fed Ex/UPS <input checked="" type="checkbox"/> DHL <input type="checkbox"/> Priority One <input checked="" type="checkbox"/> Truck <input type="checkbox"/> Ground <input type="checkbox"/> Next Day <input type="checkbox"/> Second/Third Day |
|--|--|

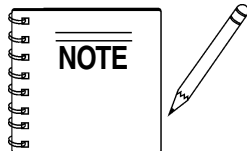

Unless otherwise indicated by customer, all orders are treated as *Standard Orders* and will ship within 24 hours. We will make every effort to ship *Air Shipments* the same day the order is received, if received prior to 2PM PST. *Stock Orders* must be noted on fax or web order form.

WE ACCEPT ALL MAJOR CREDIT CARDS!



MODULAR LIGHT TOWER — SAFETY MESSAGE ALERT SYMBOLS

FOR YOUR SAFETY AND THE SAFETY OF OTHERS!

Safety precautions should be followed at all times when operating this equipment. Failure to read and understand the Safety Messages and Operating Instructions could result in injury to yourself and others.

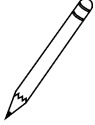
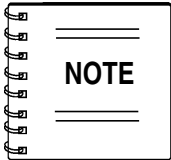

This Owner's Manual has been developed to provide complete instructions for the safe and efficient operation of the *MQ Whiteman Modular Light Tower (MLT)*. Before using this Light Tower, ensure that the operating individual has read and understands all instructions in this manual.

SAFETY MESSAGE ALERT SYMBOLS

The three (3) Safety Messages shown below will inform you about potential hazards that could injure you or others. The Safety Messages specifically address the level of exposure to the operator, and are preceded by one of three words: **DANGER**, **WARNING**, or **CAUTION**.



DANGER: You **WILL** be **KILLED** or **SERIOUSLY** injured if you **DO NOT** follow directions.



WARNING: You **CAN** be **KILLED** or **SERIOUSLY** injured if you **DO NOT** follow directions.

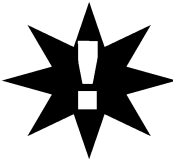

CAUTION: You **CAN** be injured if you **DO NOT** follow directions.

Potential hazards associated with the *MLT Light Tower* operation will be referenced with Hazard Symbols which appear throughout this manual, and will be referenced in conjunction with Safety Message Alert Symbols.

HAZARD SYMBOLS



Lethal Exhaust Gases



Engine exhaust gases contain poisonous carbon monoxide. This gas is colorless and odorless, and can cause death if inhaled. **NEVER** operate this equipment in a confined area or enclosed structure that does not provide ample free flow air.



Explosive Fuel

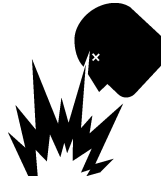

Diesel fuel is extremely flammable, and its vapors can cause an explosion if ignited. **DO NOT** start the engine near spilled fuel or combustible fluids. **DO NOT** fill the fuel tank while the engine is running or hot. **DO NOT** overfill tank, since spilled fuel could ignite if it comes into contact with hot engine parts or sparks from the ignition system. Store fuel in approved containers, in well-ventilated areas and away from sparks and flames.



Burn Hazards



Engine components can generate extreme heat. To prevent burns, **DO NOT** touch these areas while the engine is running or immediately after operations. Never operate the engine with heat shields or heat guards removed.



Respiratory Hazard



ALWAYS wear approved *respiratory* protection when required.



Rotating Parts



NEVER operate equipment with covers, or guards removed. Keep fingers, hands, hair and clothing away from all moving parts to prevent injury.

MODULAR LIGHT TOWER — SAFETY MESSAGE ALERT SYMBOLS



Accidental Starting



ALWAYS place the power source, circuit breakers or **ON/OFF** switch in the **OFF** position, when the generator is not in use, unless connected to transfer switch.



Respiratory Hazard



ALWAYS wear approved respiratory protection.



Sight and Hearing hazard

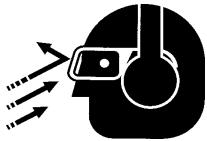

ALWAYS wear approved eye and hearing protection.



Equipment Damage Messages

Other important messages are provided throughout this manual to help prevent damage to your light tower, other property, or the surrounding environment.



Over-Speed Conditions



NEVER tamper with the factory settings of the engine governor settings. Personal injury and damage to the engine or equipment can result if operating speed ranges above maximum allowable.

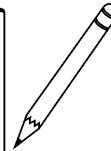
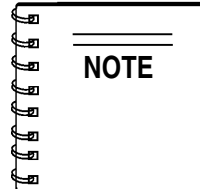

This light tower, other property, or the surrounding environment could be damaged if you **do not** follow instructions.

MODULAR LIGHT TOWER — RULES FOR SAFE OPERATION

CAUTION:

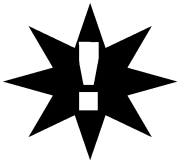

Failure to follow instructions in this manual may lead to serious injury or even death! This equipment is to be operated by trained and qualified personnel only! This equipment is for industrial use only.

The following safety guidelines should always be used when operating the light tower/generator:

GENERAL SAFETY

- **DO NOT** operate or service this equipment before reading this entire manual. 
- This equipment should not be operated by persons under 18 years of age.
- **NEVER** operate this equipment without proper protective clothing, shatterproof glasses, steel-toed boots and other protective devices required by the job. 
- **NEVER** operate this equipment when not feeling well due to fatigue, illness or taking medicine. 
- **NEVER** operate this equipment under the influence of drugs or alcohol. 
- **NEVER** use accessories or attachments, which are not recommended by Multiquip for this equipment. Damage to the equipment and/or injury to user may result.
- Manufacture does not assume responsibility for any accident due to equipment modifications.
- Whenever necessary, replace nameplate, operation and safety decals when they become difficult read.
- **ALWAYS** check all the bolts on the light tower for tightness.
- **NEVER** touch the hot exhaust manifold, muffler or cylinder. Allow these parts to cool before servicing engine or generator. 
- **High Temperatures** – Allow the engine to cool before adding fuel or performing service and maintenance functions. Contact with *hot* components can cause serious burns.

- The engine of this light tower/generator requires an adequate free flow of cooling air. Never operate the generator in any enclosed or narrow area where free flow of the air is restricted. If the air flow is restricted it will cause serious damage to the generator engine and may cause injury to people. Remember the engine of the light tower/generator gives off **DEADLY** carbon monoxide gas.

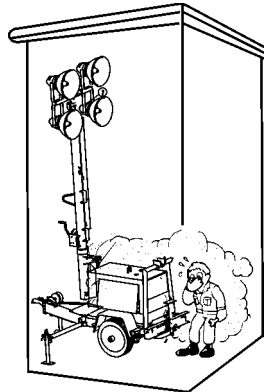

- **ALWAYS** refuel in a well-ventilated area, away from sparks and open flames.
- Always use extreme caution when working with **flammable** liquids. When refueling, **stop the engine** and allow it to cool. **DO NOT smoke** around or near the machine. Fire or explosion could result from fuel vapors, or if fuel is spilled on a hot engine. 
- **NEVER** operate the light tower/generator in an explosive atmosphere or near combustible materials. An explosion or fire could result causing severe *bodily harm or even death*.
- Topping-off to filler port is dangerous, as it tends to spill fuel.
- **ALWAYS** make sure that the light tower/generator is secure on level ground so that it cannot slide or shift around, endangering workers. Also keep the immediate area free of bystanders.
- **ALWAYS** use a **trained technician** to install and remove a floodlight, or replace any damaged fixture wiring.
- **NEVER** leave any grease or oil residue on glass surface when replacing or removing bulbs. This can create hot spots, reducing the service life of the bulb or causing outer jacket to burst.
- **ALWAYS** make sure trailer is placed on level ground with outriggers extended before raising tower. Outriggers must remain extended while tower is up.
- **NEVER** raise, lower or relocate mast while unit is operating!
- **ALWAYS** keep area behind trailer clear of people while raising and lowering mast.
- **NEVER** remove safety pin or pull mast locking pin while tower is in an raised position!
- **CHECK** the mast and winch cables for wear. If any problem occurs when lower or raising the tower **STOP** immediately!
- **NEVER** pivot or retract mast while unit is operating.

MODULAR LIGHT TOWER — RULES FOR SAFE OPERATION

DANGER:



The **6 DANGER** items listed below are considered high **DANGER** areas and should be adhered to. Failing to understand these areas could result in **bodily harm electrical shock, electrocution, and even death!** Please pay close attention when operating the light tower.

DANGER

This light tower/generator is equipped with a **ground terminal** for your protection. Always complete the **grounding path** from the light tower to an external grounding source. The possibility exists of **electrical shock, electrocution, and even death!** if the light tower is not grounded



DANGER

ALWAYS make certain light tower is well grounded and securely fastened to a good earth ground (ground rod). The possibility exists of electrical shock, electrocution, and even death! if the light tower is not grounded.



DANGER

NEVER operate this light tower/generator, or handle any electrical equipment while standing in **water, while bare foot, while hands are wet, or in the rain. Dangerous electrical shock could occur causing severe bodily harm or even death.**

DANGER

ALWAYS Keep electrical cords in good condition. Worn, bare or frayed wiring can cause electrical shock, thus causing **bodily harm or even death.**



DANGER

NEVER grab or touch a live power cord with wet hands, the possibility exists of **electrical shock, electrocution, and even death!**

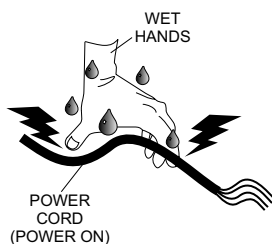

DANGER

To prevent serious injury or death, ALWAYS make sure area above trailer is open and clear of overhead **powerlines** and **obstructions.** The tower extends in excess of 30 ft. (9 meters).

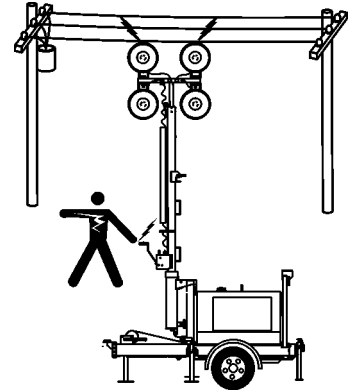

- **ALWAYS** keep the immediate area surrounding the light tower clean, neat, and free of debris.
- **ALWAYS** lower the tower when not in use, or if high winds or electrical storms are expected in the area.
- **NEVER** pivot or retract mast while unit is operating.
- **ALWAYS** position and operate light tower on a firm, level surface.
- **NEVER touch** bulbs while in use. Bulbs become extremely hot when in use! Allow bulbs and fixture to cool at least 10-15 minutes before handling.

Maintenance Safety

- **NEVER** lubricate components or attempt service on a running light tower/generator.
- **ALWAYS** allow the light tower/generator a proper amount of time to cool before servicing.
- Keep the light tower/generator in proper running condition.
- Fix damage to the light tower/generator immediately and always replace broken parts.

Emergencies

- **ALWAYS** know the location of the nearest **fire extinguisher.**



- **ALWAYS** know the location of the nearest **first aid kit.**



- In emergencies **always** know the location of the nearest phone or **keep a phone on the job site.** Also know the phone numbers of the nearest **ambulance, doctor and fire department.** This information will be invaluable in the case of an emergency.



MODULAR LIGHT TOWER — OPERATION AND SAFETY DECALS

Machine Safety Decals

This modular light tower is equipped with a number of safety decals. These decals are provided for operator safety and maintenance information. The illustration below and on the next page shows these decals as they appear on the machine. Should any of these decals become unreadable, replacements can be obtained from your dealer.



DANGER

ELECTRICAL SHOCK HAZARD

1. **Electrically ground trailer frame to earth before operating genset.**
 - a. Screw all jacks firmly against ground.
 - b. For extra safety, also drive in ground rod and connect cable to stud welded to trailer frame.
2. **Keep light fixture receptacles dry.**
 - a. Screw caps on hand tight to seal receptacles when not in use.
 - b. Do not screw light fixture into receptacle if receptacle is wet.
3. **Beware of cut power cord.**
 - a. When raising, lowering or rotating tower, be sure to watch power cord.
 - b. If power cord gets cut or crushed, replace before operating light tower.
4. **Turn off genset when performing electrical work.**
 - a. Turn off genset before re-lamping fixture.
 - b. Turn off genset before replacing ballast.
5. **Take extra precautions when troubleshooting electrical problems.**
 - a. Only use a voltmeter with two well insulated pin probes rated for 600 volts.
 - b. Ground trailer frame securely with all jacks and a backup ground cable.
 - c. Inspect ground cable between genset and trailer frame.
 - d. Treat all conductors as potentially hot.
 - e. Proceed through circuits systematically, operating only one section at a time.
 - f. Before disconnecting ballast, turn off circuit breaker and wait 30 seconds for capacitor to discharge.
 - g. If all the lights are out and the ballasts are receiving power, suspect burned out power cable. Shut down genset and fully inspect power cable and junction box.

DCL102



DANGER

ALWAYS SECURE THE SPRING LOADED TOWER LOCK BY INSERTING THE ATTACHED RING PIN.

REMOVE THE RING PIN BEFORE ATTEMPTING TO PIVOT TOWER TO THE HORIZONTAL POSITION.

DCL104



DANGER

HIGH VOLTAGE

DCL100



WARNING

ALL JACKS MUST BE SWIVELED TO HORIZONTAL BEFORE MOVING TRAILER

DCL106



WARNING

FAILURE TO TURN OFF LIGHTS BEFORE STOPPING ENGINE MAY RESULT IN GENERATOR DAMAGE AND VOID WARRANTY

DCL113

GROUNDING LUG



DCL105

ST 175/80 D13 TIRES
MAX 1360 LBS AT 50 PSI
COLD. INFLATE TO 32 PSI

DCL110

NAMEPLATE

CONTACT MULTIQUIP SERVICE DEPT.

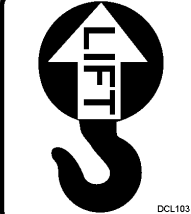

LIFT

DCL103



CAUTION

SHUT DOWN GENERATOR BEFORE CHANGING LAMPS

DCL117

NOTICE

CHECK WHEEL LUGS

1. ON FIRST TRIP, TIGHTEN LUG AT START AND EVERY 50 MILES FOR FIRST 200 MILES. CORRECT TORQUE IS 90-95 FOOT POUNDS.
2. THEREAFTER, CHECK WHEEL LUG NUTS BEFORE EACH TRIP.
3. FOLLOWING WINTER STORAGE, CHECK BEFORE BEGINNING TRIP.
4. FOLLOWING EXCESSIVE BRAKING, INSPECT WHEEL LUGS.

19021



CAUTION

BEFORE TELESCOPING TOWER TO OPERATING HEIGHT, PULL LOCKING PIN. ↓

DCL118



WARNING

TO ENSURE PROPER LIGHT TOWER STABILITY AND RESISTANCE TO WIND A **MINIMUM OF 560 LBS.** MUST BE ADDED TO THE LIGHT TOWER (TRAILER) BED. IF THIS WEIGHT REQUIREMENT IS NOT OBSERVED THE POSSIBILITY EXISTS THAT THE TOWER COULD **TIP OVER** CAUSING SERIOUS BODILY INJURY EVEN DEATH!

P/N 29425



WARNING

STAY CLEAR OF BOOM



DCL108

MODULAR LIGHT TOWER — OPERATION AND SAFETY DECALS

DANGER

FORKS MUST BE INSERTED INTO FORK POCKETS A MINIMUM OF 24 INCHES. ATTACH FORKLIFT SAFETY CHAIN TO EQUIPMENT BEFORE LIFTING. FAILURE TO DO SO MAY RESULT IN THE EQUIPMENT FALLING OFF THE FORKS.

DCL111

TOWING INSTRUCTIONS

1. READ OPERATORS MANUAL
2. CHECK THAT HITCH AND COUPLING DEVICE ARE RATED EQUAL TO OR GREATER THAN TRAILER "GROSS VEHICLE WEIGHT RATING".
3. CHECK HITCH AND COUPLING DEVICE FOR WORN OR DEFECTIVE PARTS. ENSURE THAT COUPLING DEVICE IS SECURE TO VEHICLE.
4. CHECK TIRES FOR TREAD WEAR AND INFLATION.
5. CONNECT SAFETY CHAINS USING CROSS PATTERN. CONNECT BREAKDOWN CHAIN TO BUMPER OR HITCH.
6. TEST BRAKES ON BOTH VEHICLES. CHECK TRAILER LIGHTS FOR PROPER OPERATION.
7. INSPECT AND GREASE BEARINGS EVERY 1000 MILES OR ONCE A YEAR.

CAUTION: TRAILER TO BE LEVEL WHEN TOWING. MAX. TOWING SPEED: 55 MPH (88 KM/H)

DCL112

OPERATING INSTRUCTIONS

START ENGINE GENERATOR

1. Check the levels of the engine oil, fuel and coolant.
2. Make sure all circuit breakers and auxiliary switches are in the OFF position before starting engine. **CAUTION:** Starting generator under load can cause damage.
3. If the engine is fitted with a glow plugs, turn the key to the preheat position and hold for 3-5 sec.
4. Turn the key to the "START" position and hold until the engine starts, then release. **CAUTION:** If the engine does not start in 20 seconds, release key and repeat steps 3 & 4.

NOTE: If unit is equipped with Auto-Shutdown, the system will automatically shut off the fuel supply if oil pressure is not obtained within 30 seconds after key is turned to "ON" position. You must return the key to the "OFF" position to restart the 30 second timer if engine does not start.

TURN ON THE FLOODLIGHTS

1. Once engine achieves operating speed and is running smoothly, turn on each floodlight circuit breaker to the "ON" position.
2. **NOTE:** Floodlights require a warm-up of 5-15 minutes before they reach full output. If shut-down, a 10 minute cool down is required before restarting.

DCL119

LIGHT CONTROL/BREAKER

DCL115

LOOSEN TO TURN

DCL116

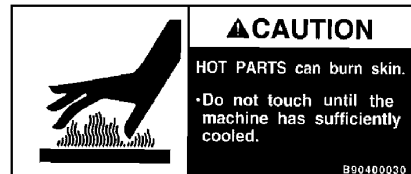

B90400030

P/N B9504000304



P/N 13118

DIESEL FUEL

P/N 29157

DANGER

HIGH VOLTAGE

P/N 29047

WARNING

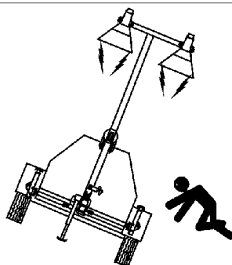

OVERHEAD HAZARD TO PREVENT SERIOUS INJURY OR DEATH

- Level trailer before use.
- Do not raise, lower or use light tower unless all outriggers and jacks are positioned on firm ground.
- Watch out for overhead obstructions, such as trees and high voltage power lines.

DCL120

DANGER!

TO PREVENT SERIOUS INJURY OR DEATH

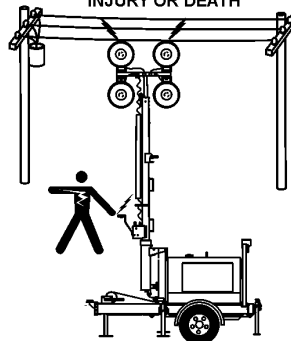

ALWAYS MAKE SURE AREA ABOVE TOWER MAST IS OPEN AND CLEAR OF OVERHEAD **POWER LINES**. THE TOWER MAST EXTENDS IN EXCESS OF 30 FT. (9 METERS).

29651

WARNING

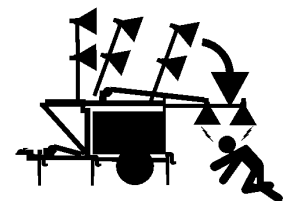

NON-VERTICAL TOWER Can Cause Severe Injury or Death

- Keep all persons clear before raising or lowering mast.
- Do not extend or retract mast unless latch is securely in place.

DCL109

MODULAR LIGHT TOWER — SPECIFICATIONS

TABLE 1. SPECIFICATIONS

Model	MLT-DA7 Generator	MLT-KD-6/KD1800Generator	MLT-SDW Welder/Generator	MLT (No Generator)
Weight (Dry)	1,588 lbs. (720 kg.)	1,764 lbs. (800 kg.)	1768 lbs. (802 kg.)	1062 lbs. (481 kg.)
Length	173 in. (1,854 mm.)	173 in. (1,854 mm.)	173 in. (1,854 mm.)	173 in. (1,854 mm.)
Height	70 in. (1,778 mm.)	70 in. (1,778 mm.)	70 in. (1,778 mm.)	70 in. (1,778 mm.)
Width	50 in. (1,270 mm.)	50 in. (1,270 m.)	50 in. (1,270 m.)	50 in. (1,270 m.)
Max. Tower Height	30 ft. (9.14 meters)	30 ft. (9.14 meters)	30 ft. (9.14 meters)	30 ft. (9.14 meters)
Support Points	4	4	4	4
Wind Stability with Genset	72 mph (116 kph)	72 mph (116 kph)	72 mph (116 kph)	44 mph 72 mph (71 kph)
Ground Clearance	6.5 in. (165 mm.)	6.5 in. (165 mm.)	6.5 in. (165 mm.)	6.5 in. (165 mm.)
Hitch Type	Adjustable 2" ball	Adjustable 2" ball	Adjustable 2" ball	Adjustable 2" ball
Tire Size	13" (330 mm.)	13" (330 mm.)	13" (330 mm.)	13" (330 mm.)
Winch Capacity	1,500 lbs. (680 kg.)	1,500 lbs. (680 kg.)	1,500 lbs. (680 kg.)	1,500 lbs. (680 kg.)
Winch Rope Wire	3/16"	3/16"	3/16"	3/16"
Floodlights	4-1000 Watt Metal Halide	4-1000 Watt Metal Halide	4-1000 Watt Metal Halide	4-1000 Watt Metal Halide
Lumens	440,000	440,000	440,000	440,000
Light Coverage	5 to 7 acres	5 to 7 acres	5 to 7 acres	5 to 7 acres
Light Termination	4 x 3-pin QD plug	4 x 3-pin QD plug	4 x 3-pin QD plug	4 x 3-pin QD plug
Sound Level @ 23 ft.	65.7 dB	65.7 dB	68.7 dB	N/A

MODULAR LIGHT TOWER — GENERAL INFORMATION

The Multiquip **modular** light tower is a general purpose floodlight tower intended for emergency and remote lighting conditions.

This **modular light tower** (MLT) can be configured to operate with four different types of power sources: The **DA-7000**, **KD-6**, **KD-1800** generators or the **SDW-225SS** welder/generator. For information regarding the generator or welder sections of the light tower, refer to the following manuals:

- DA7000SS Generator Operation and Parts Manual
- KD-6/KD1800 Generator Operation and Parts Manual
- SDW225 Welder/Generator Operation and Parts Manual

A cross-drilled T-bar allows the lights to be positioned either horizontally or vertically.

The light tower can be raised vertically in excess of 30 feet (9.0 meters) by means of a manual winch. The tower tensioning system is designed to provide the necessary tension to safely control the pivot of the tower.

The lighting system of Multiquip's modular light tower is comprised of 4 "Metal Halide" 1000 watt lamps. Each lamp has an output of 110,000 lumens yielding a total of 440,000 lumens for all four floodlights. Typical lighting coverage is between 5 to 7 acres.

Each floodlight requires a ballast for starting. Located in the tongue of the trailer is a weather resistant ballast box that contains the ballast for each floodlight. On the outside of the ballast box there is a light control panel. The panel contains the ON/OFF circuit breakers for each pair of floodlights and a ground stud for proper earth grounding.

For ease of service or transport, each floodlight is equipped with a quick-disconnect connector that allows the lamp fixture to be removed quickly. This feature is extremely useful during transport of the light tower over rough terrain. It is always best to remove the floodlights and pack them safely so they will not get damaged.

MODULAR LIGHT TOWER — DIMENSIONS

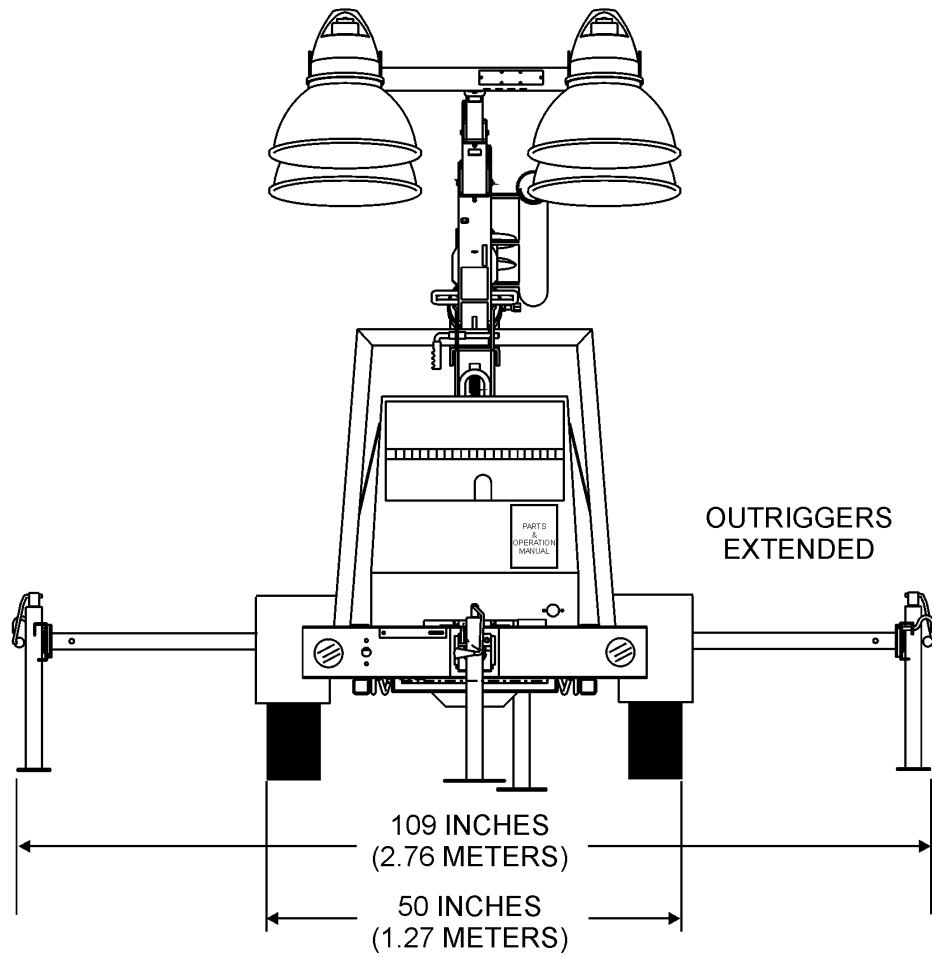
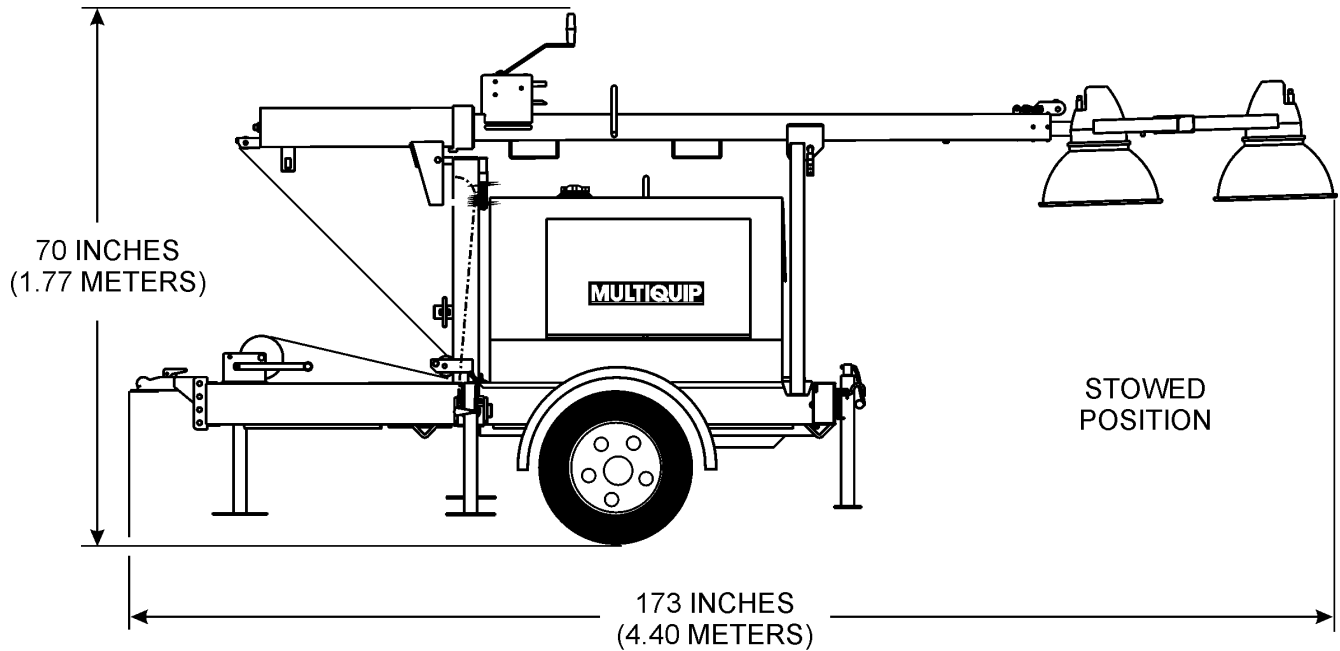

Figure 1. Dimensions (Length and Width)

MODULAR LIGHT TOWER — DIMENSIONS

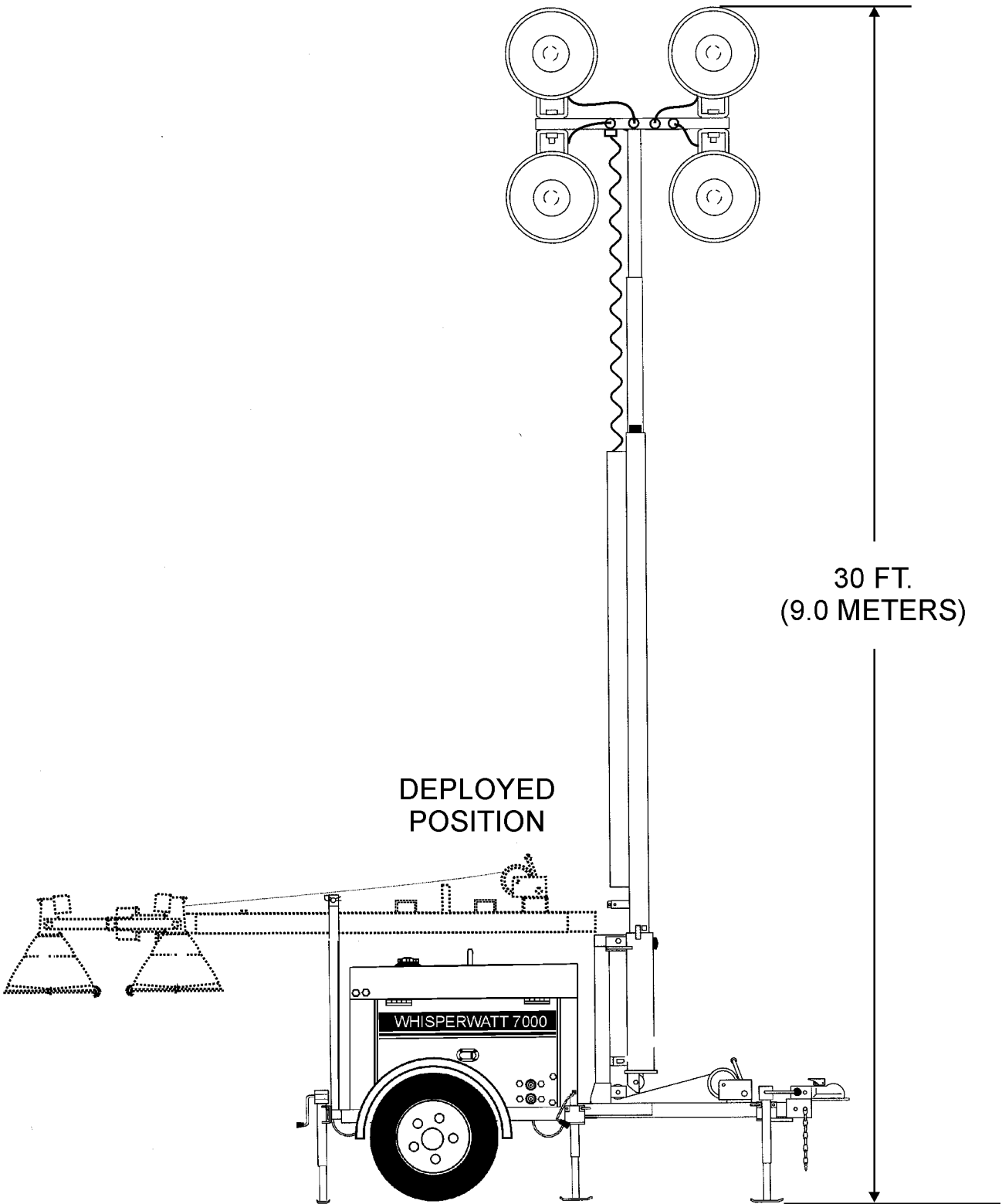

Figure2. Dimensions (Maximum Mast Height)

MODULAR LIGHT TOWER — COMPONENTS

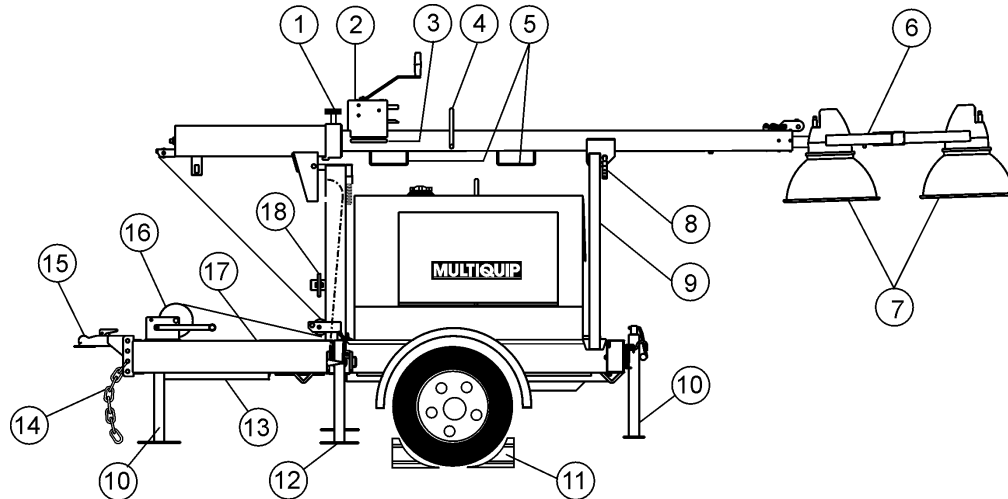
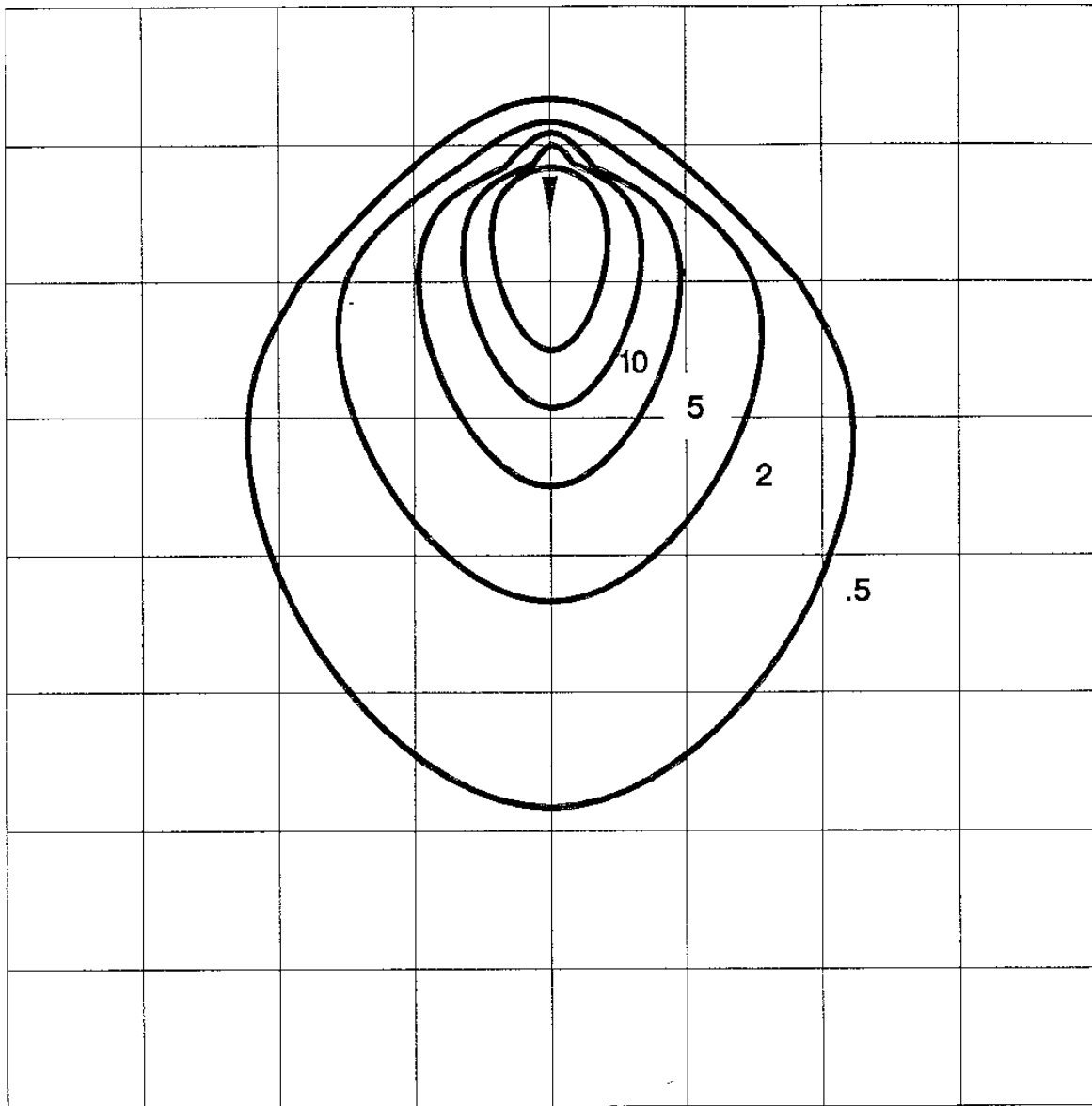

Figure 3. Components

Figure 3 shows the location of the controls and components for the Modular Light Tower. The functions of each control is described below:

1. **Mast Rotation Locking Knob** – Unscrew this knob to release mast for rotation.
2. **Vertical Mast Extension Winch** – Use this winch to extend the mast to the desire height. Maximum height is approximately 30 feet (9 meters).
3. **Mast Rotation Handle** – Grip this handle to rotate mast to desired position. To lock mast tighten mast rotation locking knob.
4. **Lifting Bail** – When lifting of the light tower by crane is required, use this lifting bail. Note: this lifting bail is balanced for a **fully configured** light tower; removal of any light tower components will un-balance the lifting bail.
5. **Forklift Pockets** – When lifting of the light tower is required, use these fork lift pockets to lift the light tower. Remember to insert the forks of the fork lift a minimum of 24 inches into the mast fork lift pockets.
6. **T-Bar** – Allows the floodlights to be adjusted vertically or horizontally.
7. **Flood Light** – 1000 watt "Metal Halide" type bulb with a 110,000 lumens capacity. Light coverage is typically between 5 to 7 acres.
8. **Tower Release Pin** – Slide this pin to release tower mast from cradle support stand.
9. **Mast Cradle Support Stand** – When towing of the light tower is required, secure the tower mast into the cradle support stand. Make sure tower release pin has been inserted and mast is locked.
10. **Jack Stands** – There are two trailer jack stands, which are located at the front and rear of the trailer. Use these 2 jack stands to level and support the light tower.
11. **Chock Blocks** – Place these blocks (not included as part of the light tower package) under each trailer wheel to prevent rolling.
12. **Outrigger Jacks** – Use these 2 outrigger jacks to level and support the light tower.
13. **Ballast Compartment** – This compartment contains the ballasts electronics for each floodlight.
14. **Safety Chain** – Always attach safety chain to the towing vehicle. Never tow the light tower with the safety chain unattached.
15. **Ball Hitch Coupler** – Attach this coupler to the towing vehicle. Use only the specified ball diameter as indicated on your coupler. Use of any other ball diameter will create an extremely dangerous condition which can result in separation of the coupler and ball or ball failure.
16. **Vertical Mast Winch** – Use this winch to raise the mast the to the vertical position. Once mast is in the full vertical position be sure to insert locking pin.
17. **Circuit Breaker and Floodlight Switch Panel** – This panel contains two single-pole 20 amp circuit breakers to protect the unit from overload and a ON/OFF circuit breaker (2) for each pair of floodlights.
18. **Mast Locking Pin** – Remove this pin while placing the tower mast in the vertical position. Insert locking pin when tower mast has reached full vertical position.

MODULAR LIGHTTOWER — FLOODLIGHT FOOTCANDLE PLOT



Horizontal Footcandles
Scale: 1 inch = 50 feet

Figure 4. Footcandle Plot Max Value = 59.00

MODULAR LIGHT TOWER — FLOODLIGHT FOOTCANDLE PLOT

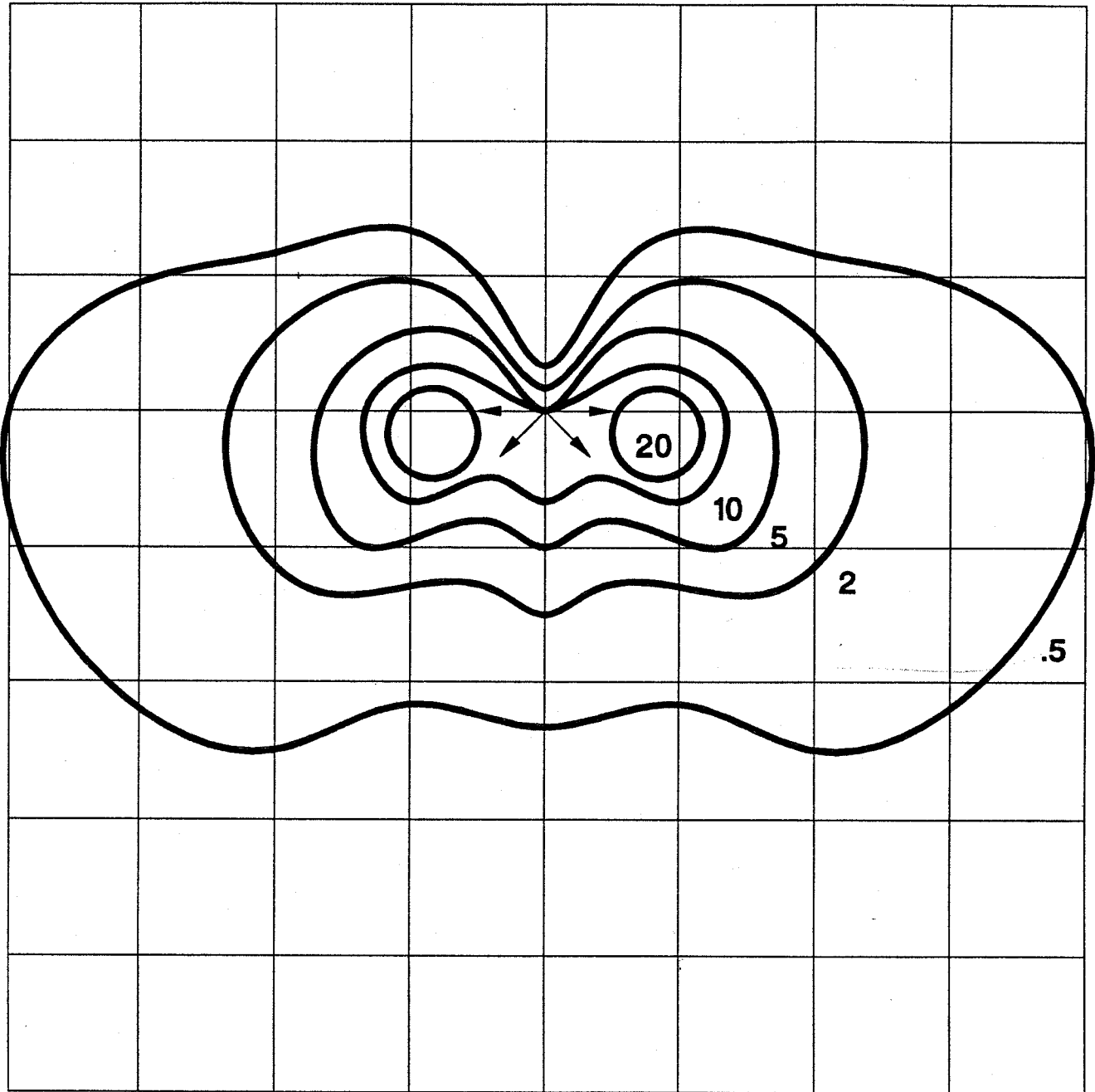

Horizontal Footcandles
Scale: 1 inch = 50 feet

Figure 5. Footcandle Plot Max Value = 24.11

MODULAR LIGHT TOWER — FLOOD LIGHT FOOTCANDLE PLOT

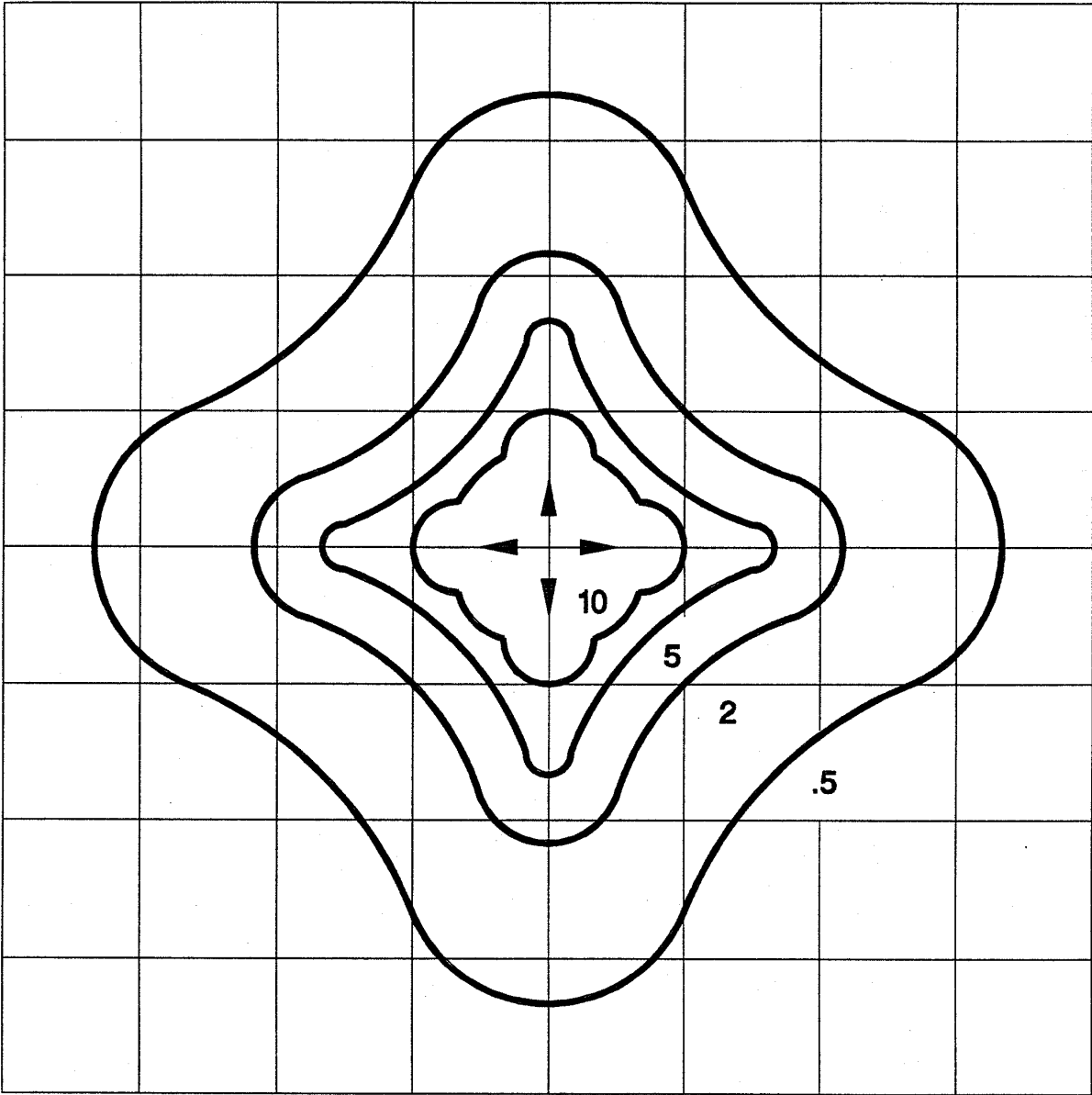

Horizontal Footcandles
Scale: 1 inch = 50 feet

Figure 6. Footcandle Plot Max Value = 15.21

MODULAR LIGHT TOWER — TOWING GUIDELINES

Towing Safety Precautions

CAUTION:

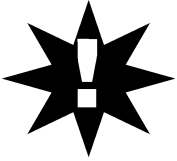

- Check with your county or state safety towing regulations department before towing your **light tower**.

To reduce the possibility of an accident while transporting the light tower on public roads, always make sure that the trailer and the towing vehicle are in good operating condition and both units are mechanically sound.

The following list of suggestions should be used when towing the light tower:

- Make sure that the hitch and coupling of the towing vehicle are rated equal to, or greater than the trailer "gross vehicle weight rating" (GVWR). See Table 2 (Trailer Specifications/Application).
- **ALWAYS** inspect the hitch and coupling for wear. **NEVER** tow the light tower's trailer with defective hitches, couplings, chains etc.
- **CHECK** the tire air pressure on both the towing vehicle and the trailer. Also check the tire tread wear on both vehicles.
- **ALWAYS** make sure the trailer section of the light tower is equipped with a "**Safety Chain**".
- **ALWAYS** attach trailer's safety chain to frame of towing vehicle.
- **ALWAYS** make sure that the vehicle and trailer directional, backup, brake, and trailer lights are connected properly and are working properly.
- Remember in most cases the maximum speed unless otherwise posted for highway towing is 45 MPH, however before towing your light tower, check your local state, and county vehicle towing requirements. Recommended off-road towing is not to exceed **10 MPH** or less depending on type of terrain.
- Place *chocked blocks* underneath wheel to prevent **rolling**, while parked.
- Depending on soil conditions and location it may be necessary to place *support blocks* underneath the trailer's bumper to prevent **tipping**, while parked.
- Inflate tires to correct pressure, inspect tires for cuts, and excessive wear. See Table 3 (Tire Wear Troubleshooting).

- Check wheel mounting lug nuts with a **torque wrench**. Torque wheel lug nuts as described in the "**Lug Nut Torque Requirements**", Table 4 .
- Make sure brakes are synchronized (electric only) and functioning properly.
- Check tightness of hanger bolt, shackle bolt, and U-bolts nuts, torque suspension hardware per Table 5.
- Avoid sudden stops and starts. This can cause skidding, or jackknifing. Smooth, gradual starts and stops will improve gas mileage.
- Avoid sharp turns to prevent rolling.
- Remove wheel stand when transporting.
- **DO NOT** transport light tower with fuel in the welder/generator fuel tank.

CAUTION:

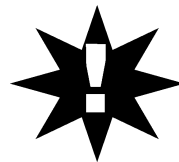

If the trailer coupler is deformed replace entire coupler. **NEVER** tow the light tower with a defective trailer coupler. There exist the possibility of the trailer separating from the towing vehicle.

Light Tower Trailer Vehicle Connection

1. Check the vehicle hitch ball, and trailer coupler for signs of wear or damage. Replace any parts that are worn or damaged before towing.
2. Use only the 2-inch ball diameter as indicated on the trailer's coupler. Use of any other ball diameter will create an extremely dangerous condition which can result in separation of the coupler and ball or ball failure.
3. Be sure the coupler is secured to the hitch ball and the lock lever is down (locked).
4. Attach safety chains as shown in Figure 7. Remember to **cross** the safety chains.
5. After towing for about 50 miles recheck the entire towing system for tightness.

Recommended Maintenance

1. Smear ball socket and clamp face with chassis grease. Periodically oil pivot points and wear surfaces of coupler with SAE 30 W motor oil.
2. When parking or storing the light tower, keep the coupler off the ground so dirt and other debris will not build up in the ball socket.

MODULAR LIGHT TOWER — TOWING GUIDELINES

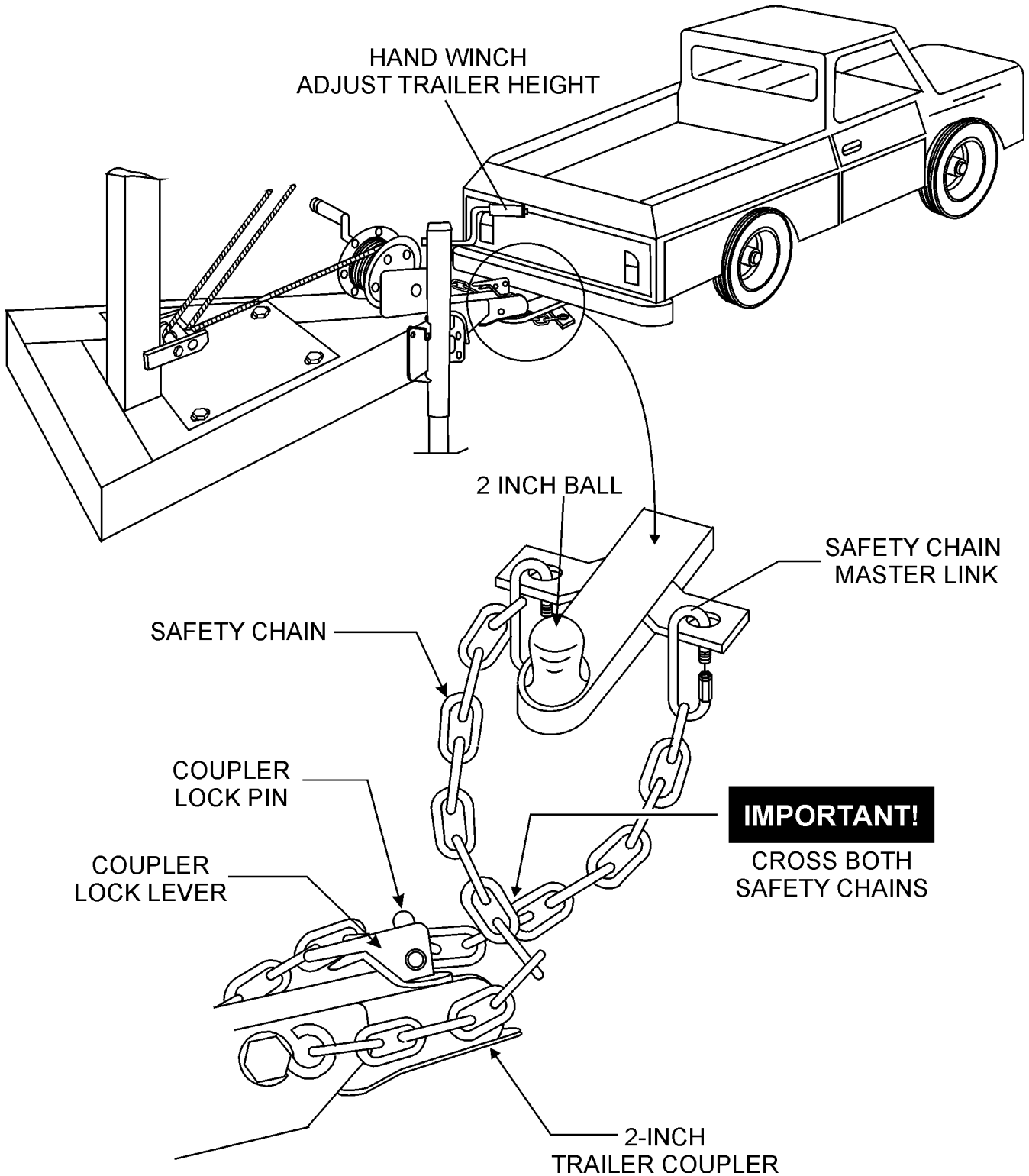
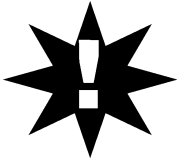

Figure 7. Safety Chains/Trailer Coupler Hook-up

MODULAR LIGHTTOWER — TRAILER SAFETY GUIDELINES

Trailer Safety Precautions

CAUTION :



ALWAYS make sure that the trailer is in good operating condition. Check the tires for proper inflation and wear. Also check the wheel lug nuts for proper tightness.

This section is intended to provide the user with trailer service and maintenance information. The service and maintenance guidelines referenced in this section apply to a wide range of trailers. Remember periodic inspection of the trailer will ensure safe towing of the equipment and will prevent damage to the equipment and personal injury.

It is the purpose of this section to cover the major maintenance components of the trailer. The following trailer components will be discussed in this section:

- Brakes
- Tires
- Lug Nut Torquing
- Suspension
- Electrical
- Brake Troubleshooting Tables

Use the following definitions when reading Tables 2.

1. **Fuel Cell** – Provides fuel for the equipment in use. Fuel cells must be empty for transport when a common carrier is required.
2. **Braking System** – System employed in stopping the trailer. Typical braking systems are electric, surge, hydraulic, hydraulic-surge and air.
3. **GVWR** – Gross Vehicle Weight Rating (**GVWR**), is the maximum number of pounds the trailer can carry, including the fuel cell (empty).
4. **Frame Length** – This measurement is from the ball hitch to the rear bumper (reflector).
5. **Frame Width** – This measurement is from fender to fender.
6. **Jack Stand** – Trailer support device with maximum pound requirement from the tongue of the trailer.
7. **Coupler** – Type of hitch used on the trailer for towing.
8. **Tires Size** – Indicates the diameter of the tire in inches (10, 12, 13, 14, etc.), and the width in millimeters (175, 185, 205 etc.). The tire diameter must match the diameter of the tire rim.
9. **Tires Ply** – The tire ply (layers) number is rated in letters; 2-ply, 4-ply, 6-ply, 8-ply, 10-ply etc.
10. **Wheel Hub** – The wheel hub is connected to the trailer's axle. See Figure 11.
11. **Tire Rim** – Tires are mounted on a tire rim. The tire rim must match the size of the tire.
12. **Lug Nuts** – Used to secure the wheel to the wheel hub. Always use a torque wrench to tighten down the lug nuts. See Table 4 and Figure 10 or lug nut tightening and sequence.
13. **Axle** – Indicates the maximum weight the axle can support in pounds, and the diameter of the axle expressed in inches (see Table 2). Please note that some trailers have a double axle. This will be shown as 2-6000 lbs, meaning two axle's with a total weight capacity of 12,000 pounds.
14. **Suspension** – Protects the trailer chassis from shocks transmitted through the wheels. Types of suspension used are leaf, Q-flex, and air-ride.
15. **Electrical** – Electrical connectors (looms) are provided with the trailer so that brake lights and turn signal lights can be connected to the towing vehicle. See Figure 12 for proper wiring connections.
16. **Application** – Indicates which units can be employed on a particular trailer.

MODULAR LIGHTTOWER — TRAILER SAFETY GUIDELINES

Table 2. Trailer Specification/Application

MODEL	APPLICATION	FUEL CELL GALLONS	BRAKE SYSTEM	GVWR LBS.	FRAME LENGTH INCHES	FRAME WIDTH INCHES	JACK STAND CAPACITY (LBS).
TRLR-10-15	TLG-12, DCA15, TLW-300	NO	NO	1900	96	50	800 FULL TILT WHEEL
TRLR-10X	TLG-12, DCA15, TLW-300	NO	NO	1900	96	50	800 FULL TILT WHEEL
TRLR-10XF	TLG-12, DCA15, TLW-300	51 GAL	NO	1900	96	50	800 FULL TILT WHEEL
TRLR-225W	DCA-10	NO	NO	2200	85	42	800 FULL TILT WHEEL
BLW-400	BLW-400	NO	ELECTRIC	2700	W/MAST 154 W/O 124	55 (78" TALL)	800 FULL TILT WHEEL
TRLR-15XF	DCA-15	41	NO	2700	124	55	800 FULL TILT WHEEL
TRLR-50X	DCA-25	NO	NO	2700	124	55	800 FULL TILT WHEEL
TRLR-50XF	DCA-25	41	NO	2700	124	55	800 FULL TILT WHEEL
TRLR-25SBT	DCA-25	NO	NO	2990	120	66	800 FULL TILT WHEEL
TRLR-70W	DCA-45, -60, 70	NO	SURGE	7000	186	77	2000 FLAT PAD
TRLR-70X	DCA-45, -60, 70	OPT	SURGE	7000	138	66	2000 FLAT PAD
TRLR-70XF	DCA-45, -60, 70	53	SURGE	7000	138	66	2000 FLAT PAD
TRLR-100XF	DCA-100, 125	150	HYDRAULIC SURGE	7000	190	76	2000 FLAT PAD
TRLR-85/125	DCA-85, 100, 125	145	HYDRAULIC	10000	186	77	2000 FLAT PAD
TRLR-150XF	DCA-150, 180	200	HYDRAULIC SURGE	11160	204	84	5000 FLAT PAD
TRLR-220XF	DCA-220	250	HYDRAULIC SURGE	14000L	222	83	5000 FLAT PAD
TRLR-300XF	DCA-300	250	HYDRAULIC SURGE	18000	238	83	5000 FLAT PAD
TRLR-400XF	DCA-400	350	ELECTRIC	18000	238	83	5000 FLAT PAD
TRLR-600XF	DCA-600, 800	550	AIR	30000	384	96	5000 FLAT PAD
TRLR-800SX	DCA-600, 800	550	AIR	30000	384	96	5000 FLAT PAD

MODULAR LIGHTTOWER — TRAILER SAFETY GUIDELINES

Table 2. Specifications/Application (Con't)

MODEL	COUPLER	TIRES	RIMS	AXLE	HUBS	SUSPENSION	ELECTRICAL
TRLR-10-15W	2" BALL CLASS 2 ADJUSTABLE	175-13C	13"X4.50"	2200 LBS. 2X2	5 LUG	3 LEAF	4 WIRE LOOM RUBBER FLAT
TRLR-10X	2" BALL CLASS 2 ADJUSTABLE	175-13C	13"X4.5"	2200 LBS. 2X2	5 LUG	3 LEAF	4 WIRE LOOM RUBBER FLAT
TRLR-10XF	2" BALL CLASS 2 ADJUSTABLE	175-13C	13"X4.5"	220 LBS. 2X2	5 LUG	3 LEAF	4 WIRE LOOM RUBBER FLAT
TRLR-225W	2" BALL CLASS 2 ADJUSTABLE	175-13B	13X4.5"	2200 LBS. 2X2	5 LUG	Q FLEX	4 WIRE LOOM RUBBER FLAT
BLW 400	2" BALL CLASS 2 ADJUSTABLE	175-13C	13 X 4.5"	2200 LBS. 2X2	5 LUG	3 LEAF	4 WIRE LOOM RUBBER FLAT
TRLR-15XF	2" BALL CLASS	B78-13LRC	13"X4.50"	3500 LBS. 2-1/2"	5 LUG	4 LEAF	4 WIRE LOOM RUBBER FLAT
TRLR-50X	2" BALL CLASS	B78-13LRC	13"X4.50"	3500 LBS. 2-13/8"	5 LUG	4 LEAF	4 WIRE LOOM RUBBER FLAT
TRLR-50XF	2" BALL CLASS	B78-13LRC	13"X4.50"	3500 LBS. 2-13/8"	5 LUG	4 LEAF	4 WIRE LOOM RUBBER FLAT
TRLR-70W	2" BALL CLASS 3" ADJUSTABLE	205-14C BIAS (4)	14"X5"	3500 LBS. 2-13/8"	5 LUG	5 LEAF	4 WIRE LOOM RUBBER FLAT
TRLR-70X	2" BALL CLASS 3" ADJUSTABLE	205-14C BIAS (4)	14"X5"	3500 LBS. 3"	5 LUG	5 LEAF	4 WIRE LOOM RUBBER FLAT
TRLR-70XF	2" BALL CLASS 3" ADJUSTABLE	205-14C BIAS (4)	14"X5"	3500 LBS. 3"	5 LUG	5 LEAF	4 WIRE LOOM RUBBER FLAT
TRLR-100XF	ADJUSTABLE 2-5/6 OPT 3" EYE	205-15C BIAS (4)	14"X5.5"	3500 LBS. 3"	5 LUG	5 LEAF	4 WIRE LOOM RUBBER FLAT
TRLR-85/125	ADJUSTABLE 2-5/6 OPT 3" EYE	ST225/75R15D RADIAL (4)	14"x6"	2-AXLE 6000 LBS.	6 LUG	7 LEAF	4 WIRE LOOM RUBBER FLAT
TRLR-150XF	3" BALL EYE	750-16 E BIAS (4)	16"X7"	2-AXLE 6000 LBS.	8 LUG	7 LEAF	4 WIRE LOOM RUBBER FLAT
TRLR-220XF	3" EYE ADJUSTABLE	ST235/85R16E RADIAL(4)	16"X7"	3-AXLE 10000 LBS.	8 LUG	Q FLEX	4 WIRE LOOM RUBBER FLAT
TRLR-300XF	3" EYE ADJUSTABLE	ST235/85R16E RADIAL(6)	16"X7"	2-AXLE 7000 LBS.	8 LUG	Q FLEX	4 WIRE LOOM RUBBER FLAT
TRLR-400XF	3" EYE ADJUSTABLE	ST235/85R16E RADIAL(6)	16"X7"	3-AXLE 10000 LBS.	8 LUG	Q FLEX	4 WIRE LOOM RUBBER FLAT
TRLR-600XF	5TH WHEEL	ST215/75R17.5H RADIAL (8)	16"X7"	3-AXLE 10000 LBS.	8 LUG	7 LEAF	6 WIRE LOOM
TRLR-800AR	5TH WHEEL	ST215/75R17.5H RADIAL (8)	16"X7"	3-AXLE 10000 LBS.	8 LUG	AIR-RIDE	6 WIRE LOOM

Brakes

If your trailer has a braking system, the brakes should be inspected the first 200 miles of operation. This will allow the brake shoes and drums to seat properly. After the first 200 mile interval, inspect the brakes every 3,000 miles. If driving over rough terrain inspect brakes more frequently.

Electric Brakes

Electrically actuated brakes (Figure 8) are similar to hydraulic brakes. The basic difference is that hydraulic brakes are actuated by **pressure**, while electric brakes are actuated by an **electromagnet**.

Listed below are some of the advantages that electric brakes have over hydraulic brakes:

- Brake system can be manually adjusted to provide the corrected braking capability for varying road and load conditions.
- Brake system can be modulated to provide more or less braking force, thus easing the break load on the towing vehicle.
- Brake system has very little lag time between the time the tow vehicle's brakes are actuated and the trailer's brakes are actuated.
- Brake system can provide an independent emergency brake system.

Remember in order to properly synchronize the tow vehicle's braking to that of the trailer's braking, can only be accomplished by road testing. Brake lockup, grabbiness or harshness is due to lack of synchronization between the tow vehicle and the trailer being towed or under-adjusted brakes.

Before any brake synchronizations adjustments can be made, the trailer brakes should be burnished-in by applying the brakes 20-30 times with approximately a 20 mph decrease in speed, e.g. 40 mph to 20 mph. Allow ample time for brakes to cool between application. This allows the brake shoes to slightly be seated into the brake drum surface.

Figure 8 displays the major electric brake components that will require inspection and maintenance. Please inspect these components as required. Reference Table 7 for electric brake troubleshooting guidelines.

Electric Brake Adjustment

1. Place the trailer on jack stands. Make sure that the jack stands are placed on secure level ground.
2. Check the wheel and drum for free rotation.
3. Remove the adjusting hole cover from the adjusting slot at the bottom brake backing plate.
4. With a screwdriver or standard adjusting tool, rotate the star wheel of the adjuster assembly to expand the brake shoes.
5. Adjust the brake shoes outward until the pressure of the lining against the wheel drum makes the wheel difficult to turn.
6. Rotate the star wheel in the opposite direction until the wheel rotates freely with slight lining drag.
7. Replace the adjusting hole cover and lower the trailer to the ground.
8. Repeat steps 1 through 6 on the remaining brakes.

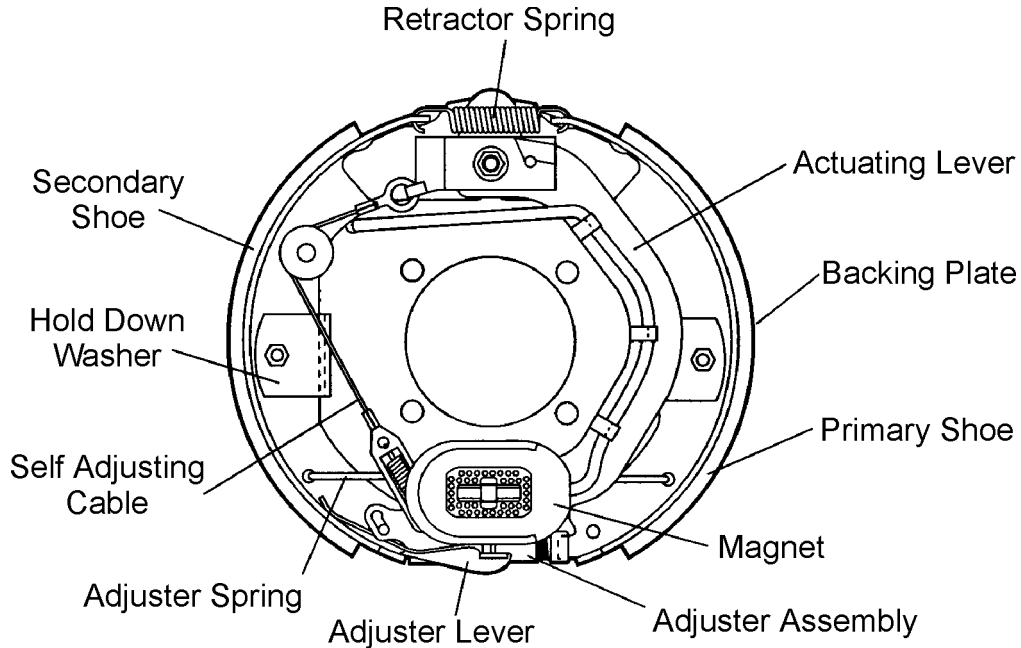

Figure 8. Electric Brake Components

Hydraulic/Air/Surge Brakes

Hydraulic brakes (Figure 9) should not require any special attention with the exception of routine maintenance such as shoe and lining replacement. These brakes can be adjusted in the same manner as electric brakes. Brake lines should be periodically checked for cracks, kinks, or blockage.

Figure 9 below display's the major hydraulic/air/surge brake components that will require inspection and maintenance. Please inspect these components as required using steps 1 through 6 as referenced in the electric brake adjustments section. Reference Table 6 for hydraulic brake troubleshooting guidelines.

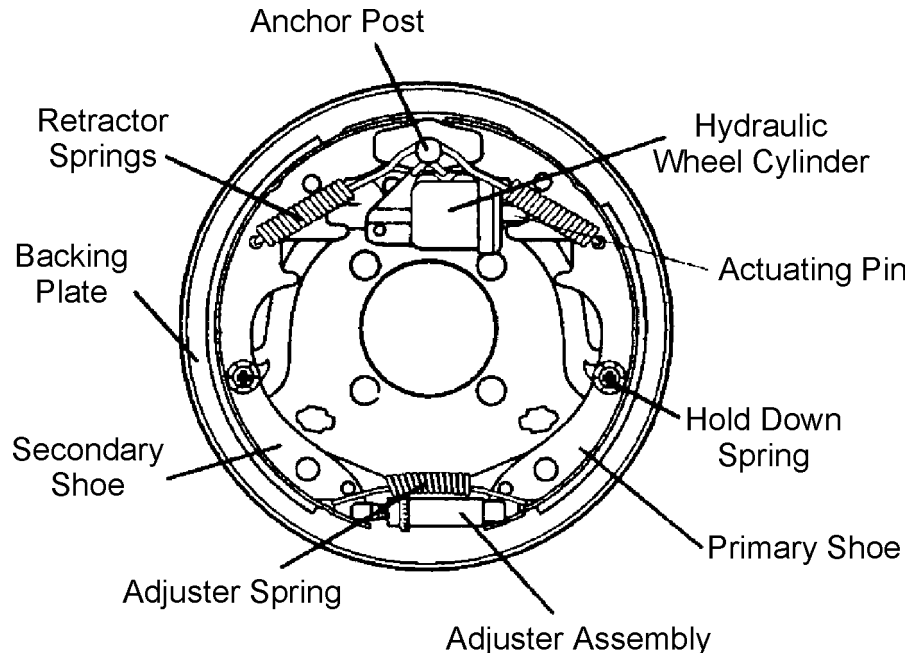

Figure 9. Hydraulic Brake Components

MODULAR LIGHTTOWER — TRAILER SAFETY GUIDELINES

Tires/Wheels/Lug Nuts

Tires and wheels are a very important and critical components of the trailer. When specifying or replacing the trailer wheels it is important the wheels, tires, and axle are properly matched.

CAUTION:

DO NOT attempt to repair or modify a wheel. **DO NOT** install an inter-tube to correct a leak through the rim. If the rim is cracked, the air pressure in the inter-tube may cause pieces of the rim to explode (break-off) with great force and can cause serious eye or bodily injury.

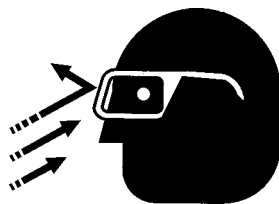
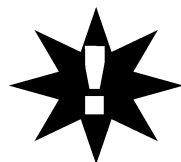

Tires Wear/Inflation

Tire inflation pressure is the most important factor in tire life. Pressure should be checked cold before operation. **DO NOT** bleed air from tires when they are hot. Check inflation pressure weekly during use to insure the maximum tire life and tread wear.





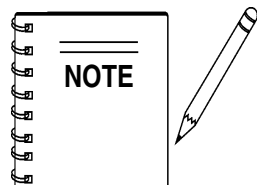
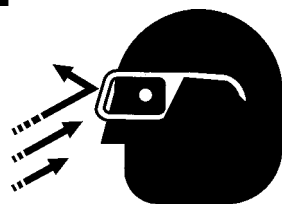
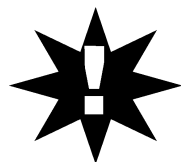

Table 3 (Tire Wear Troubleshooting) will help pinpoint the causes and solutions of tire wear problems.

CAUTION:



ALWAYS wear safety glasses when removing or installing force fitted parts. Failure to comply may result in serious injury.

TABLE 3 TIRE WEAR TROUBLESHOOTING

WEAR PATTERN	CAUSE	SOLUTION	
	Center Wear	Over Inflation	Adjust pressure to particular load per tire manufacturer.
	Edge Wear	Under Inflation	Adjust pressure to particular load per tire manufacturer.
	Side Wear	Loss of chamber or overloading.	Make sure load does not exceed axle rating. Align wheels.
	Toe Wear	Incorrect toe-in	Align wheels.
	Cupping	Out-of balance	Check bearing adjustment and balance tires.
	Flat Spots	Wheel lockup & tire skidding.	Avoid sudden stops when possible and adjust brakes.

Suspension

The leaf suspension springs and associated components (Figure 11) should be visually inspected every 6,000 miles for signs of excessive wear, elongation of bolt holes, and loosening of fasteners. Replace all damaged parts (suspension) immediately. Torqued suspension components as detailed in Table 4.

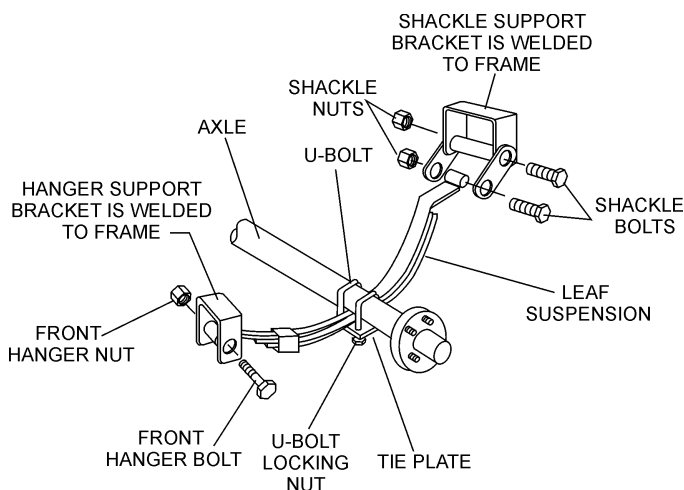

Figure 11. Major Suspension Components

MODULAR LIGHT TOWER — TRAILER SAFETY GUIDELINES

Table 4. Suspension Torque Requirements

Item	Torque (Ft.-Lbs.)
3/8" U-BOLT	MIN-30 MAX-35
7/16" U-BOLT	MIN-45 MAX-60
1/2" U-BOLT	MIN-45 MAX-50
SHACKLE BOLT SPRING EYE BOLT	SNUG FIT ONLY. PARTS MUST ROTATE FREELY. LOCKING NUTS OR COTTER PINS ARE PROVIDED TO RETAIN NUT-BOLT ASSEMBLY.
SHOULDER TYPE SHACKLE BOLT	MIN-30 MAX-50

Lug Nut Torque Requirements

It is extremely important to apply and maintain proper wheel mounting torque on the trailer. Be sure to use only the fasteners matched to the cone angle of the wheel. Proper procedure for attachment of the wheels is as follows:

1. Start all wheel lug nuts by hand.
2. Torque all lug nuts in sequence. See Figure 10. **DO NOT** torque the wheel lug nuts all the way down. Tighten each lug nut in 3 separate passes as defined by Table 5.

Table 5. Tire Torque Requirements

Wheel Size	First Pass FT-LBS	Second Pass FT-LBS	Third Pass FT-LBS
12"	20-25	35-40	50-65
13"	20-25	35-40	50-65
14"	20-25	50-60	90-120
15"	20-25	50-60	90-120
16"	20-25	50-60	90-120

3. After first road use, retorque all lug nuts in sequence. Check all wheel lug nuts periodically.

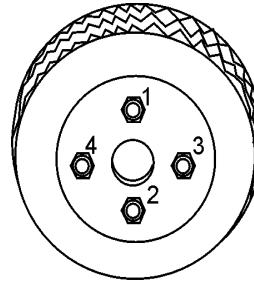

4-LUG NUTS

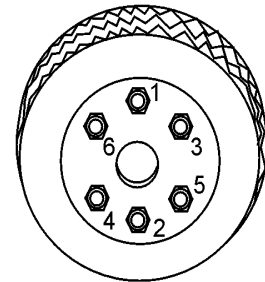

6-LUG NUTS

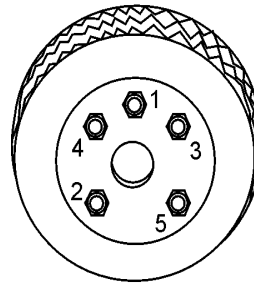

5-LUG NUTS

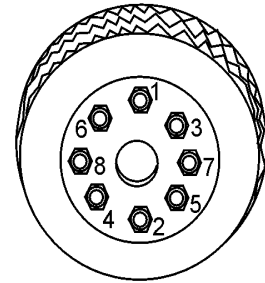

8-LUG NUTS

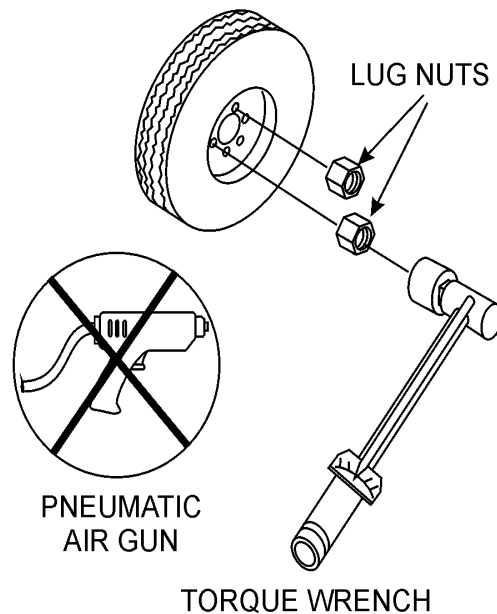
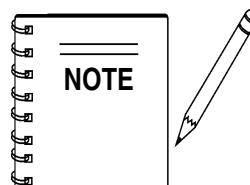

Figure 10. Wheel Lug Nuts Tightening Sequence



NEVER! use an pneumatic air gun to tighten wheel lug nuts.

MODULAR LIGHT TOWER — TRAILER WIRING DIAGRAM

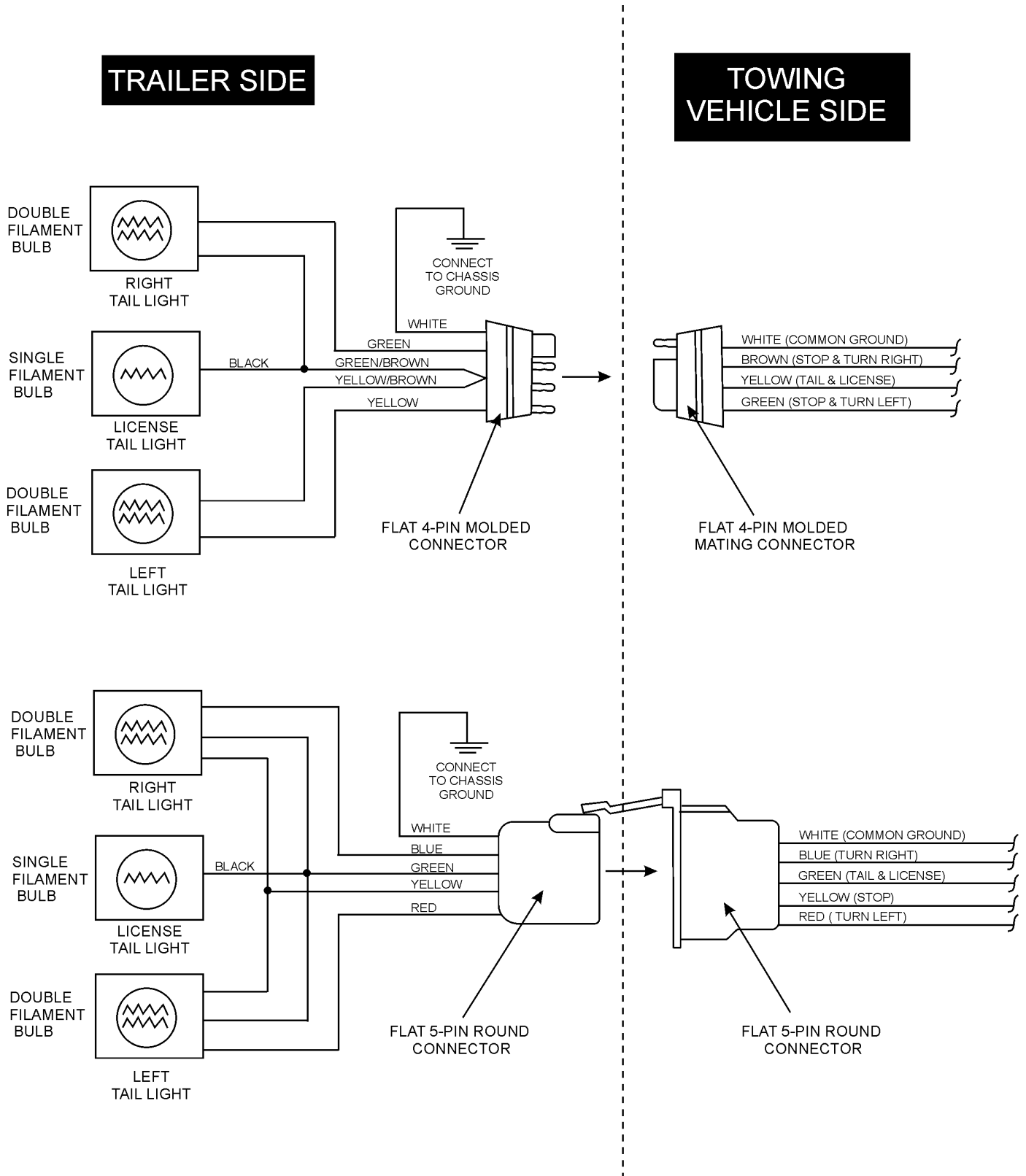

Figure 12. Typical Trailer Wiring Diagram

NOTE:
LIGHTS ARE ORIENTED FROM THE DRIVER'S SEAT

MODULAR LIGHTTOWER —TRAILER BRAKES (HYDRAULIC)

TABLE 6. HYDRAULIC BRAKE TROUBLESHOOTING

SYMPTON	POSSIBLE CAUSE	SOLUTION
No brakes	Is the brake line broken or kinked?	Repair or replace.
Weak brakes or brakes pull to one side.	Is the brake lining glazed?	Reburnish or replace
	Is the trailer overloaded?	Correct weight.
	Are the brake drums scored or grooved?	Machine or replace.
	Is the tire pressure correct?	Inflate all tires equally per manufacturer guidelines.
	Are the tires unmatched on the same axle?	Match tires.
Locking brakes.	Are the brake components loose, bent or broken?	Replace components.
	Are the brake drums out-of-round?	Replace.
Noisy brakes.	Is the brake system lubricated?	Lubricate.
	Are the correct brake components installed?	Replace and correct.
Dragging brakes.	Is the brake lining thickness correct or innstalled incorrectly?	Install new shoes and linings.
	Is there enough brake fluid or correct fluid?	Fill with dot 4 fluid.

MODULAR LIGHT TOWER — TRAILER BRAKES (ELECTRIC)

TABLE 7. ELECTRIC BRAKE TROUBLESHOOTING

SYMPTOM	POSSIBLE CAUSE	SOLUTION
No brakes or intermittent brakes.	Any open circuits or broken wires?	Find and correct.
	Any short circuits?	Find and correct.
	Faulty controller?	Test and correct.
	Any loose connections?	Find and repair.
	Is the ground wire secure?	Find and secure.
Weak brakes or brakes pull to one side.	Is there grease or oil on the magnets or lining?	Clean or replace.
	Are the connections corroded?	Clean and correct cause of corrosion.
	Are the brake drums scored or groved?	Machine or replace.
	Are the brakes synchronized?	Synchronize brakes.
Locking brakes.	Are the brake components loose, bent or broken?	Replace components.
	Are the brake drums out-of round?	Replace.
Noisy brakes.	Is the brake system lubricated ?	Lubricate.
	Are the correct brake components installed?	Replace and correct.
Dragging brakes.	Are the wheel bearings adjusted correctly?	Adjust.

MODULAR LIGHT TOWER — T-BAR INSTALLATION

CAUTION:

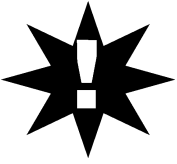

Pay close attention to ventilation when operating the generator in enclosed areas. The engine exhaust contains noxious elements.

Indoor Installation

Exhaust gases from gasoline engines are extremely poisonous. Whenever an engine is installed indoors the exhaust fumes must be vented to the outside. The engine should be installed at least two feet from any outside wall. Using an exhaust pipe which is too long or too small can cause excessive back pressure which will cause the engine to heat excessively and possibly burn the valves.

Eliminate the danger of deadly carbon monoxide gas. Remember that exhaust fumes from any gasoline or diesel engine are very poisonous if discharged in a closed area. If the light tower is installed indoors, you must make provisions for venting the engine exhaust to the outside of the building.

T-Bar and Floodlight Assembly

1. Install and secure T-Bar assembly as shown in Figure 8 using the supplied hardware.
2. Attach and secure the four flood light assemblies to the T-Bar as shown in Figure 13.

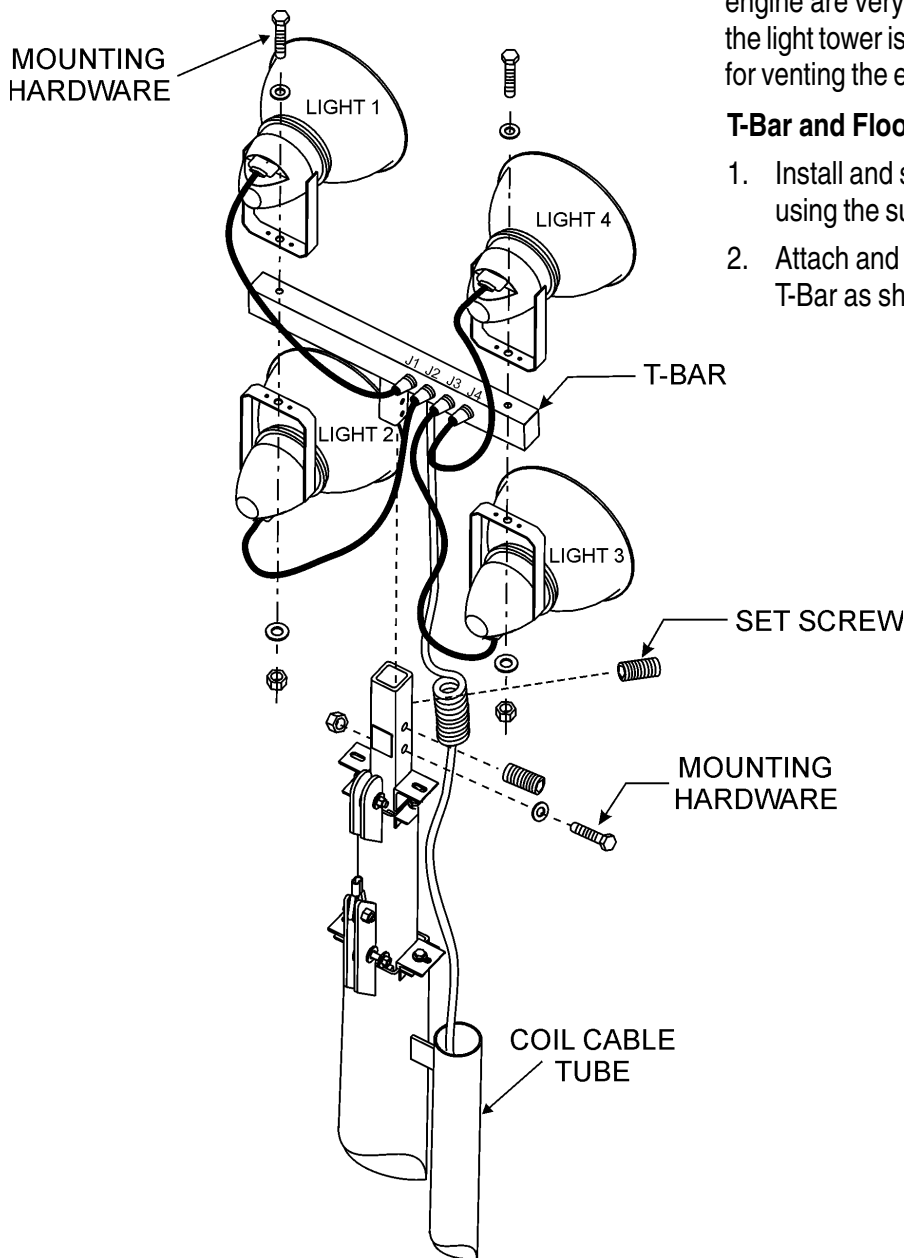

Figure 13. T-Bar Assembly

MODULAR LIGHT TOWER — TOWER MAST PRE-SETUP

WARNING:



ALWAYS check overhead for clearance of the mast. **NEVER** raise the mast in the vicinity of power lines! **DO NOT** stand behind the trailer while the mast is being raised or lowered.

Outriggers and Support Stands

1. Make sure both outriggers are extended. To extend the outriggers, pull the locking pin on the outrigger and hold while sliding out the outrigger assembly.
2. As soon as the pin clears the travel position hole, release it and continue sliding out the outrigger. The pin must snap into the outrigger locking hole in the extended position.
3. After extending all outriggers, rotate all trailer **jack stands** into the foot down position, then turn the crank handle on the **jack stands** clockwise to lower it and level the light tower.
4. Check behind the light tower and make sure all personnel and objects are clear of the tower mast.

Mast (Bottom Tower Section)

Follow the steps below to raise the bottom tower mast:

1. To release the mast from the support stand locking cradle, **PULL** the large cradle locking pin (see Figure 3, item 8). This will unlock the mast from the horizontal position.
2. Remove the bottom mast quick release locking pin (see Figure 3, Item 18, before raising tower to the vertical position.
3. To place the mast in the vertical position, **TURN** the vertical winch hand lever (Figure 3, item 16) clockwise until the mast is pointing upwards at 90 degrees.
4. Once the mast in the vertical position, insert the quick release locking pin to prevent the mast from falling.

DANGER:



Stay out of the travel path of the tower mast while raising or lowering. **ALWAYS** be careful to check that the mast does not interfere with any obstacles, especially overhead power lines. Contact with high voltage power lines could damage the equipment and cause ***serious injury or even death to personnel.***

Mast (Top and Center Tower Sections)

Once the tower mast has been locked into its vertical position, the top and center tower sections can now be raised. These two tower sections allow the flood lights to be extended upwards in excess of 30 ft. Perform the following steps when extending the floodlights:

1. Locate the "vertical mast extension hand winch", see Figure 3, Item 2.
2. Turn the vertical mast extension hand winch lever clockwise, and observe that the flood lights begin to climb upward.
3. Continue turning the hand winch lever in the clockwise direction until the desired height has been reached.
4. Release the hand winch lever, this winch is of the self-locking type. The tension on the cable will keep the mast sections in place.

Lowering Mast (Top and Center Tower Sections)

1. Turn the vertical mast extension hand winch lever counter-clockwise, and observe that the flood lights begin to drop downward.
2. Continue turning the hand winch lever counter-clockwise until the top and center mast sections have been fully retracted.

Lowering Mast (Bottom Section)

1. Remove the quick release locking pin to allow the bottom mast section to be lowered to the horizontal section.
2. Turn the vertical mast hand winch lever counter-clockwise, and observe that bottom tower mast begins to approach the horizontal position.
3. Continue turning the vertical hand winch lever in the counter-clockwise direction. As the bottom tower mast approaches the locking cradle, pull the tower release pin to allow the tower mast to rest in the cradle.
4. Once the bottom mast is resting in the cradle of the tower support stand, align the hole on the mast with the hole on the cradle and insert locking pin.

MODULAR LIGHT TOWER — ENGINE PRE-SETUP

WARNING:



The engine's exhaust contains harmful emissions. **ALWAYS** ventilate the exhaust when operating inside tunnels, excavations or buildings. Direct exhaust away from nearby personnel.

Before Starting

1. Be sure to disconnect the electrical load and switch the main circuit breaker to the "OFF" position prior to starting the engine.
2. Never start the engine with any circuit breakers in the "ON" position.
3. Make sure the light tower/generator is positioned on firm level ground. Check the lubricating oil level prior to starting the engine. The engine oil level must be maintained between two notches on the oil dipstick.
4. When there is not enough lubricating oil, fill the crankcase with high grade motor oil. Use a high quality detergent oil classified CC or higher.
5. Check the coolant level in the radiator and sub-tank. Replenish with antifreeze as necessary. Always maintain the coolant level between the **FULL** and **LOW** markings on the coolant container. Be sure that the radiator cap is fastened securely.

CAUTION:



- Check the fuel level on the fuel gauge. When fuel is low, fill the fuel tank with clean fresh unleaded automotive gasoline or diesel fuel.
- If fuel spillage occurs, completely wipe up the spilled fuel immediately.
- **NEVER** turn the key to the "**START**" position while the engine is running.

Starting

NEVER operate the light tower with the engine compartment doors open. Operation with the doors open may cause insufficient cooling to the unit, and damage may result.

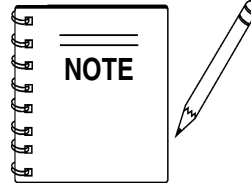

For the starting and operation of the engine and generator of the light tower, refer to the appropriate Operation Manual for your light tower.

Shutdown

Shut-down the engine as specified in the engine manual provided with the light tower.

MODULAR LIGHTTOWER — OPERATION

Operation

Proceed with this section only if the following have been completed:

- Outriggers have been fully extended to prevent the trailer from tipping.
- All tower mast sections have been raised to the desired height.
- Bottom tower mast is locked in place.
- Light tower trailer support stands have been positioned properly and the trailer is level.
- Flood lights have been adjusted to desired position.
- Chocked blocks have been positioned under each wheel to prevent trailer from rolling.
- Engine section of the light tower has been running for at least 3-5 minutes without any abnormal noises.
- Flood lights **DO NOT** interfere with any overhead obstructions.
- Flood light power cables have been plugged into the appropriate receptacles (J1-J4) on the T-Bar assembly.
- Light tower trailer frame has been grounded correctly.

If **ALL** of the above conditions have been met, proceed and turn on the flood lights as follows:

Turning On Flood Lights

1. Plug the connector end of the attached power cable into the 120 VAC twist-lock output receptacle on the generator/welder (Figure 14). This cable provides 120 VAC power to the ballast box located near the trailer tongue.
2. Set the main circuit breaker on the welder/generator to the ON position. In addition it may be necessary to turn on another breaker if the receptacle is protected. Refer to the Operation Manual for your specified generator or welder.

3. Set circuit breaker CB-1 (page 41) on the **ballast box** to the ON position.
4. Wait a few minutes for the ballast to activate. Observe that flood lights #1 and #2 are ON.
5. Set circuit breaker CB-2 on the **ballast box** to the ON position.
6. Wait a few minutes for the ballast to activate. Observe that flood lights #3 and #4 are ON.
7. If any of the flood lights are not ON refer to the troubleshooting section of this manual.

Turning Off Flood Lights

1. Set circuit breakers CB-1 and CB-2 on the **ballast box** to the OFF position. Observe that all four flood lights are OFF.
2. Allow flood lights to cool (15 minutes) if service or removal of bulb is required.
3. Set main circuit breaker on generator or welder to the OFF position.
4. Shut-down generator or welder as specified in Operation Manual.
5. Lower light tower mast as outlined in the Pre-Setup section of this manual.

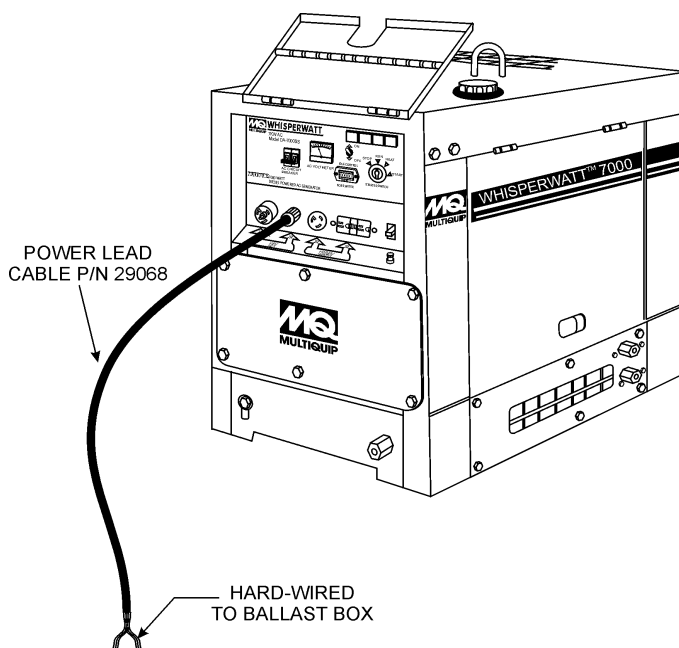

Figure 14. Power cable Connection

MODULAR LIGHT TOWER — MAINTENANCE

Check Cable Wear

The wire rope (cable) that raises and extends the mast is a very important part of the light tower. There is one cable that raises and extends the lower portion of the mast. There is a second cable that serves to extend the top portion of the mast. Wire rope (cable) will fail if it is worn, frayed, misused, crushed, kinked or damaged in any way. Always check the mast cable and pulleys for any abnormalities before use. Do not use it if there is even the slightest cause for concern.

When either cable needs to be replaced, they should both be replaced at the same time. This is most easily done by positioning the mast in the horizontal resting position. Then disassemble the mast by disconnecting the cables from the mast and sliding the sections apart. **WARNING!** The mast sections are heavy and awkward. Use proper lifting devices and procedures. Then the lower cable should be disconnected from the winch.

The mast sections, latches, cable clamps, pulleys, etc. should be inspected at this time and repaired or replaced as necessary. There are a total of 4 pulleys. They should be removed, and replaced if worn or damaged, as they can cause premature cable failure if they are in poor condition. Reassemble the cable to the top section of the mast as shown in the diagram and slide it into the middle section of the mast. Reconnect the cable to the top of the middle section of the mast.

Reassemble the cable to the middle of the mast, as shown in the diagram, and slide it into the bottom section of the mast. Route the cable through the 2 pulleys in the mast pivot assembly, as shown in the Figure 15. Then route the cable through the lower pulley located on the trailer, and reattach it to the winch.

Raise, extend, retract and lower the mast several times to verify correct operation.

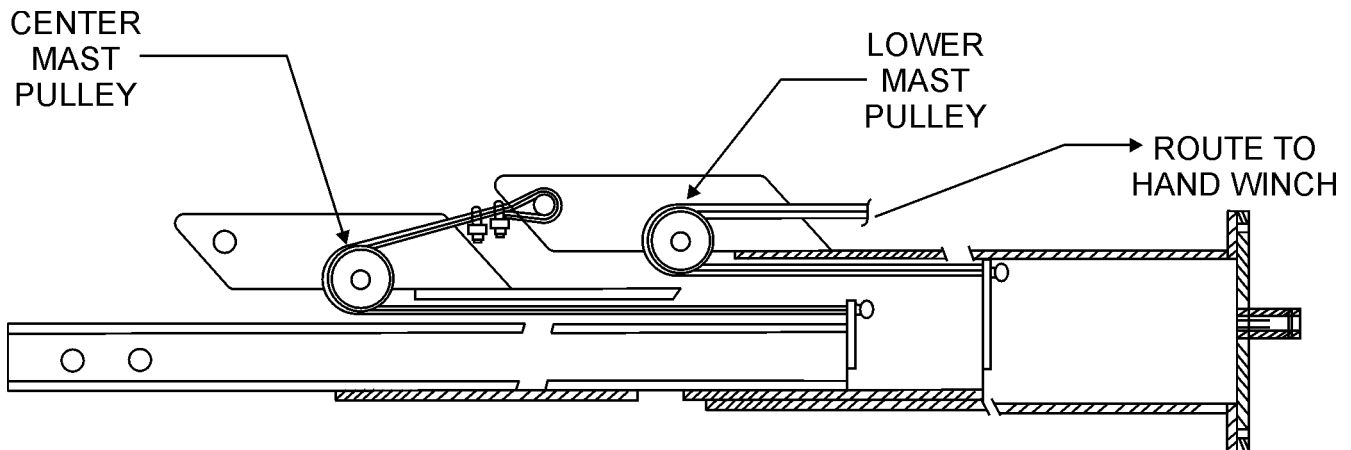

Figure 15. Cable Pulley Routing

MODULAR LIGHT TOWER — PREPARATION FOR LONG -TERM STORAGE

Generator Storage

For storage of the generator for over 30 days, the following is required:

- Drain the fuel tank completely.
- Run the engine until **all** the fuel is completely consumed.
- Completely drain the oil from the crankcase and refill with fresh oil.
- Disconnect the **negative** battery cable from the battery.
- Clean all external parts of the generator with a cloth.
- Cover the generating set and store in a clean, dry place.

MODULAR LIGHT TOWER — TROUBLESHOOTING

TABLE 8. MODULAR LIGHT TOWER TROUBLESHOOTING

SYMPTOM	POSSIBLE PROBLEM	SOLUTION
Lamp will not start.	Lamp Burned Out?	Test the lamp in a fixture which is operating properly. Replace as necessary.
	Lamp Loose in Socket?	Inspect lamp base to see if there is arcing at center contact button. Tighten lamp snugly. Check socket for damage. Replace if defective.
	Floodling Plugs Not Tight?	Check plug and receptacle. Tighten if loose.
	Defective Ballast?	Interchange ballast plugs in generator enclosure. if lamp starts, replace ballast. Check ballast wiring against diagram. Check for swollen capacitor, charred wiring, core and coil or other signs of excessive heat.
	Low Voltage?	Check line voltage at ballast input. Voltage should be within 10% of name plate rating when operating at normal load. Increase supply voltage or remove external load.
	Improper Ballast?	Proper HID lamps will perform erratically or fail to start on an improper ballast. The ballast name plate data must agree with the line voltage and lamp used. Improper ballast causes lamp failure. Note: Mercury lamps of the same wattage will operate properly on Metal Halide ballasts.
	Improper Lamp Operating Position (Metal Halide only)?	Operating position should agree with the lamp etch. A BU-HOR lamp can be operated base up vertical to and including the horizontal and a BD can be operated base down vertical to, approaching, but not including the horizontal. A lamp operated beyond the specified position may not start.
	Lamp has been Operating: Cool Down Time Insufficient?	HID lamps (High Pressure Sodium, Metal Halide, Mercury Vapor) require from 4 to 8 minutes cool-down time before restarting. Switch off breaker and allow lamp to cool.
Lamp flickers and goes out intermittent or cycling.	Improper Ballast?	Improper ballasting can cause flickering or erratic operation. In the start-up period the lamp may ignite, start to warm-up and then extinguish (cycle).
	New Lamp?	Under certain conditions new lamps may "cycle". Usually after 3 tries to start at 30 to 60 second intervals, lamps will stabilize and operate satisfactorily.
	Defective Lamp?	Replace lamp.

MODULAR LIGHT TOWER — TROUBLESHOOTING

TABLE 8. MODULAR LIGHT TOWER TROUBLESHOOTING (CONTINUED)

SYMPTOM	POSSIBLE PROBLEM	SOLUTION
Lamp starts slowly (ARC does not strike when switch is first turned on)	Defective Lamp?	Lamp may glow for extended period of time. Replace after checking voltage and ballast.
Circuit breaker trips on lamp start-up	Short Circuit or Ground?	Check wiring against diagram. Check for shorts or ground.
Lamp light output low	Normal Lamp Depreciation?	Replace Lamp.
	Dirty Lamp or Fixture?	Clean lamp and fixture.
	Defective Ballast?	Interchange ballast plugs in generator enclosure. If lamp returns to normal light output, replace ballast. Check for swollen capacitors, charred wiring, core and coil, or other signs of excessive heat.
	Wrong Voltage?	Check voltage at ballast input. Voltage should be within 10% of nameplate rating. Check wiring connections for voltage loss. Check socket contact point.
	Improper Ballast?	Check ballast nameplate against lamp data.
Lamp colors different.	Normal Lamp Depreciation?	Lamp output and brightness decreases and color changes slightly as lamps age. Spot replacement with new lamps may cause noticeable differences in lamp colors. Group replacement minimizes color differences.
	Dirty Fixture?	Dirty fixtures will cause lamps to appear different in color. Clean fixture.
	Wrong Lamp?	Check data on lamps which appear different in color. Replace with correct color lamp.
ARC tube discolored or swollen.	Over Voltage from Power Supply?	Check voltage at ballast. Check for current or voltage surges. Check for shorted capacitors and replace if defective.
	Improper Ballast?	Lamp operated on ballast designed for higher wattage lamp. Check ballast nameplate against lamp data.
Short lamp life.	Lamp Damaged?	Check for outer bulb cracks. If air enters outer bulb, arc tube may continue to burn for 100 hours before failure. Check for bulb cracks where glass meets the base due to tightening lamp too firmly in socket or scoring of glass where socket inadvertently touches the lamp bulb. Look for broken arc tube or loose metal parts. Replace lamp. (Bulb leads will cause oxidation of metal parts.)
	Improper Ballast?	Ballast nameplate data should agree with lamp line voltage and lamp use. If improper ballast is used, the lamp life will be shortened. A mismatch may also cause the ballast to fail.

MODULAR LIGHTTOWER — TROUBLESHOOTING

TROUBLESHOOTING GUIDE

Use the following procedure to determine which of the four floodlights is not functioning:

Connections:

1. Make sure that floodlight #1 power cable is plugged into the J1 connector on the T-Bar assembly.
2. Make sure that floodlight #2 power cable is plugged into the J2 connector on the T-Bar assembly.
3. Make sure that floodlight #3 power cable is plugged into the J3 connector on the T-Bar assembly.
4. Make sure that floodlight #4 power cable is plugged into the J4 connector on the T-Bar assembly.
5. Make sure that 120 VAC is present at the generator's output receptacle. This can be accomplished by disconnecting the power cable and measuring the voltage across the connector pins with an AC voltmeter.
6. With the voltmeter set to the AC position, insert the negative lead of the AC voltmeter into pin **W** (neutral) on the receptacle.
7. Insert the positive lead of the voltmeter into pin **X** (hot for CB1 and fan) on the receptacle, and observe that 120 VAC is present.
8. Next, insert the positive lead of the voltmeter into pin **Y** (hot for CB2) on the receptacle, and observe that 120 VAC is present.
9. If the correct voltages are present at the generator's output receptacle, plug the power cable from the ballast compartment into the 120 VAC twist-lock receptacle on the generator or welder.

Starting:

1. Start the welder or generator and verify that there are no abnormal sounds.
2. Turn both **CB1** and **CB2** circuit breakers to the ON position.
3. Wait a few minutes and determine which flood light is not igniting.
4. If one of the floodlights is **OFF**, disconnect its power cable and plug it into a receptacle that is known to be working. **DO NOT** unplug a power cable from the T-Bar while power is being supplied by the generator. Always turn the circuit breaker **OFF** before un-plugging a power cable.
5. If the floodlight still does not ignite after plugging it into a working receptacle (120 VAC present), then it can be assumed that the ballast for that flood light is defective. Replace ballast.

Ballast Removal:

1. Remove the power cable from the generator or welder, and make sure that no voltage is being supplied to the ballast compartment.
2. Remove the four screws securing the ballast cover, and remove cover.
3. Remove the defective ballast (see Ballast Compartment assembly drawing, page 74), taking care to guard against electrical shock when coming in contact with the ballast and capacitor. The capacitor is known to store an electrical charge, that when discharged could result in a harmful shock.

MODULAR LIGHT TOWER — SCHEMATIC DIAGRAM

LIGHT TOWER SCHEMATIC DIAGRAM

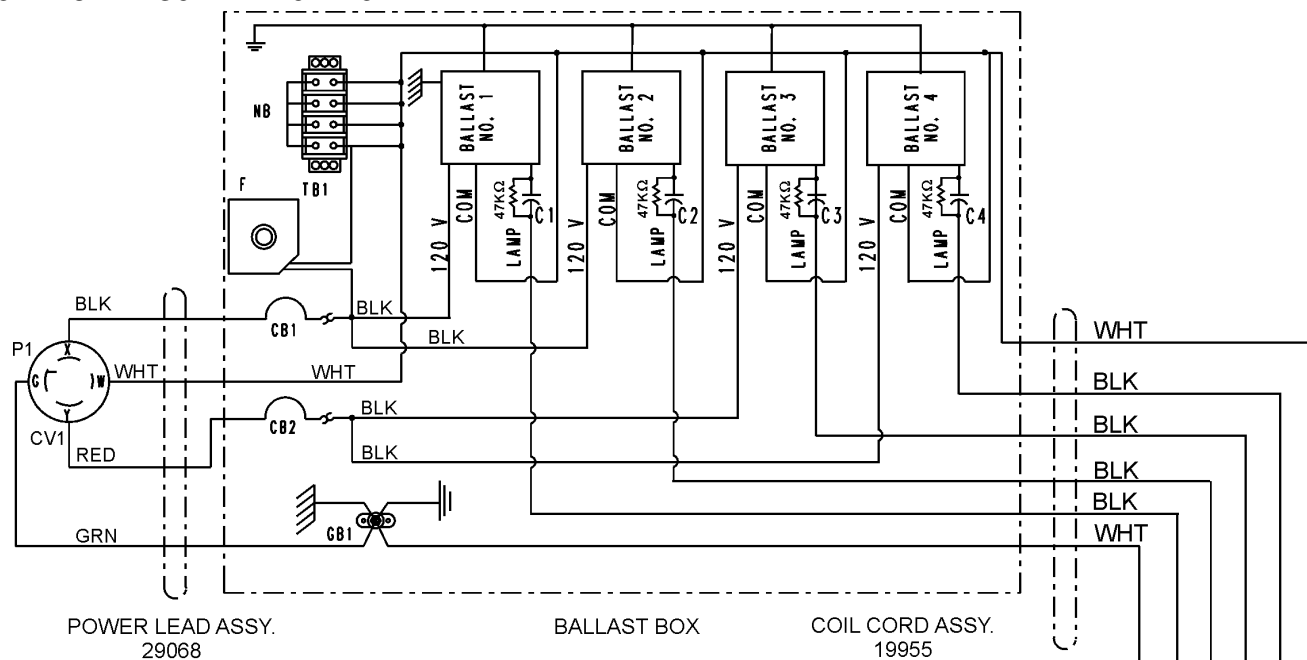

NOTE

Capacitors C1 thru C4 are 480 VAC, 24 μ f. In addition a 47K Ω (1/2 watt) resistor is installed across the capacitor terminals.

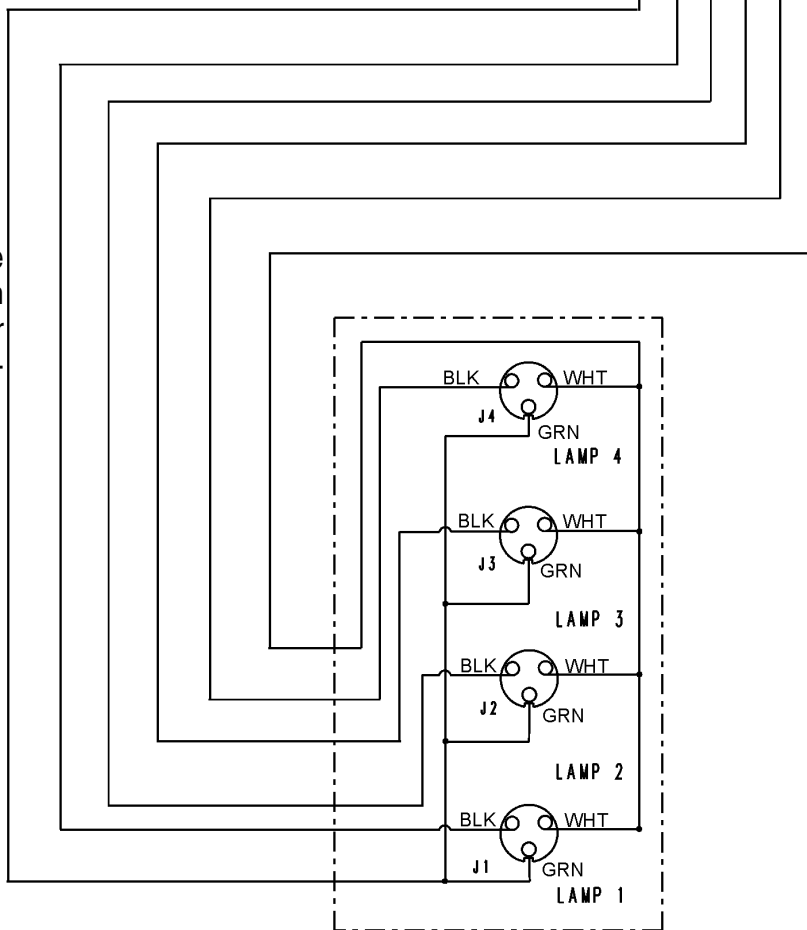

T-BAR ASSEMBLY - TWR, 19940

MODULAR LIGHT TOWER — BALLAST COMPARTMENT WIRING DIAGRAM.

BALLAST COMPARTMENT WIRING DIAGRAM

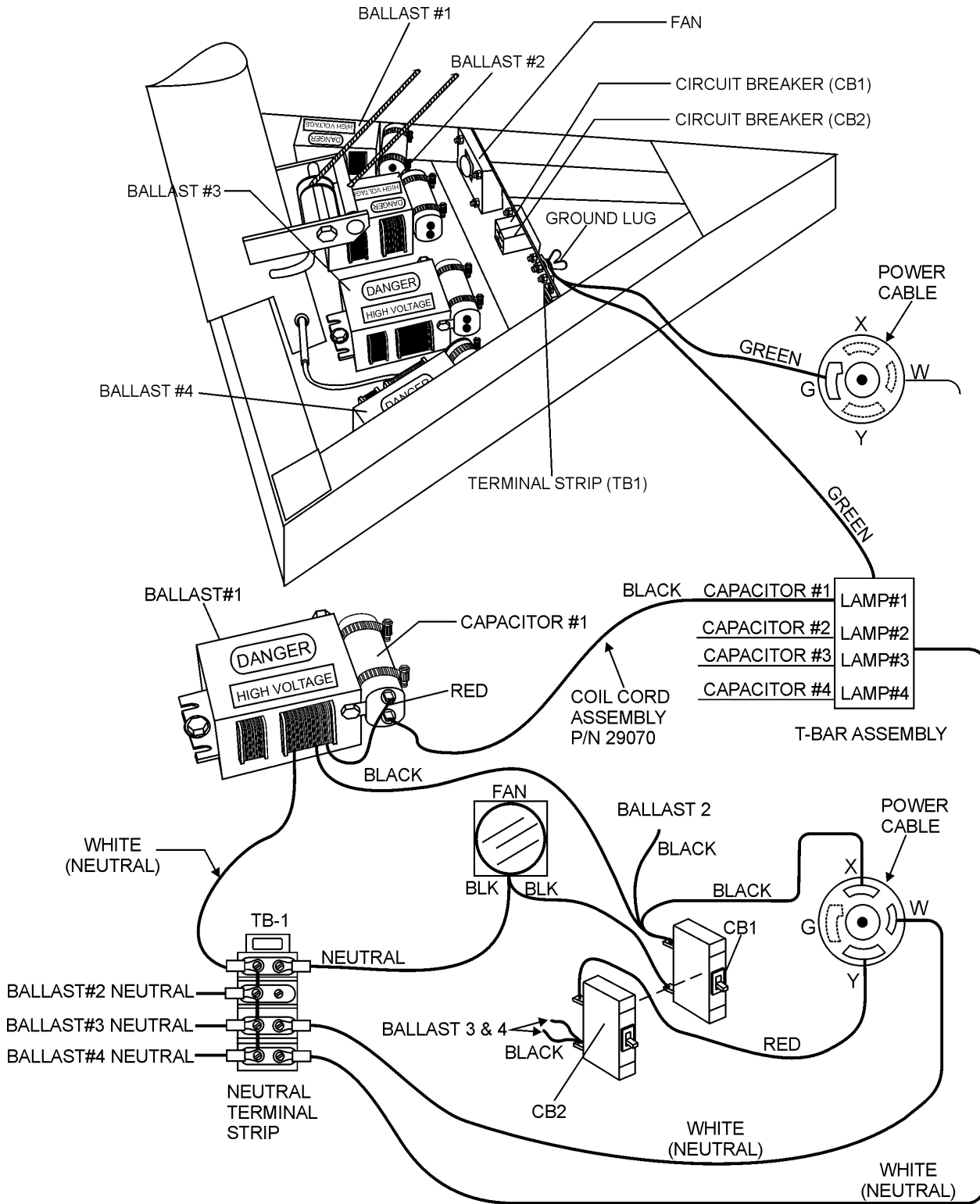

MODULAR LIGHT TOWER— ELECTRIC SWITCH WIRING DIAGRAM

ELECTRIC FUEL SWITCH WIRING DIAGRAM.

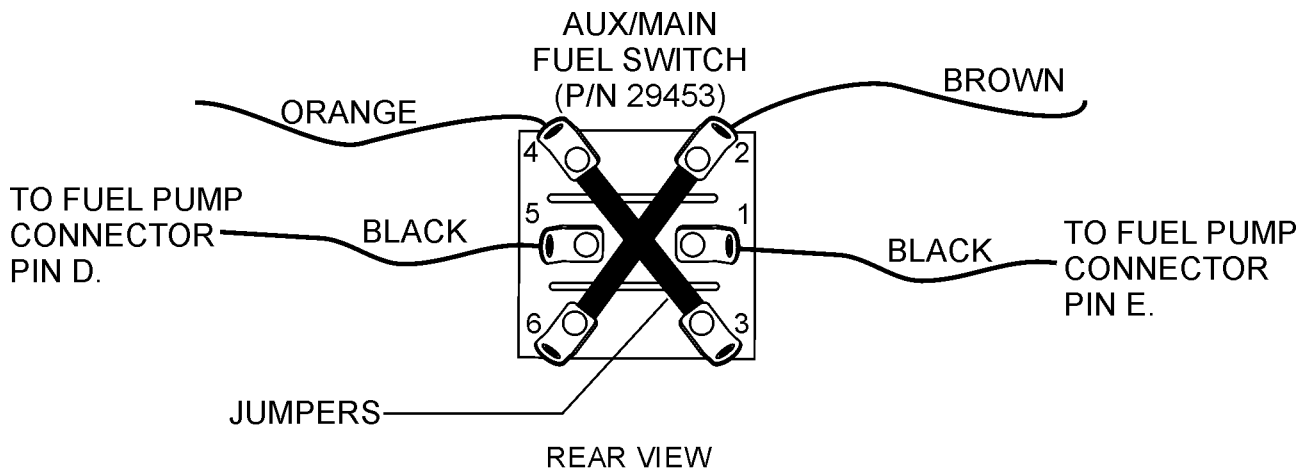
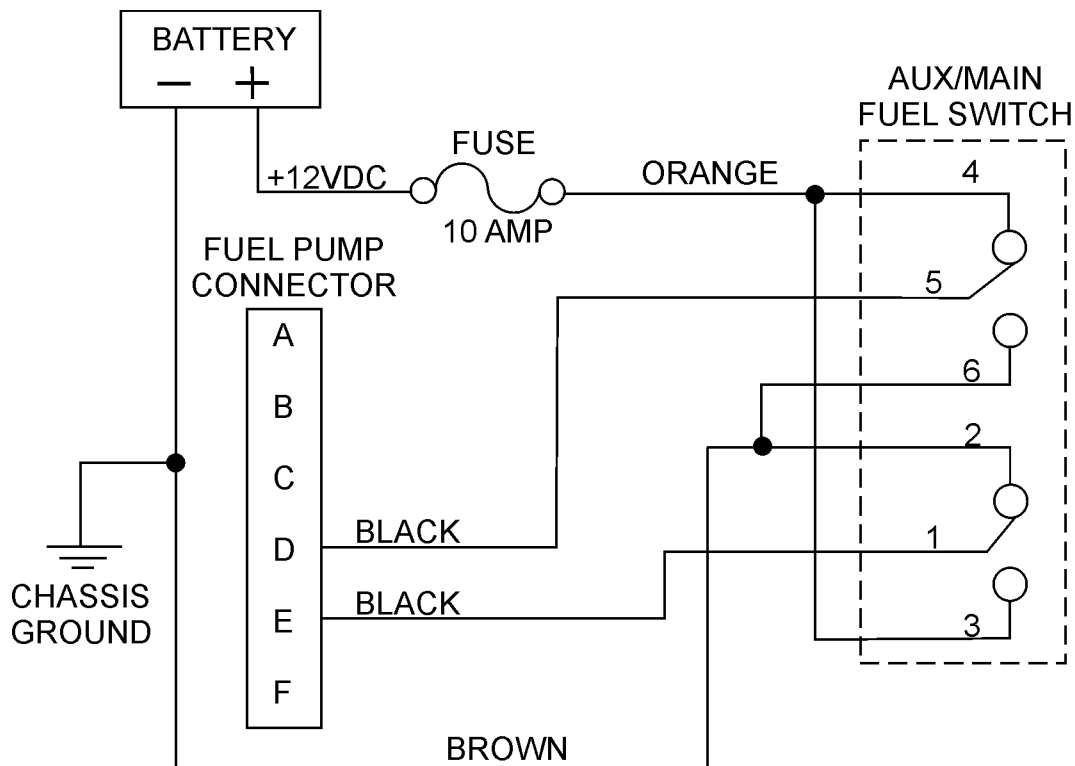

NOTE:
SWITCH POSITION SHOWN
IS FOR THE AUXILIARY
FUEL TANK (UP). DOWN
POSITION OF SWITCH
IS FOR MAIN TANK.

EXPLANATION OF CODE IN REMARKS COLUMN

How to read the marks and remarks used in this parts book.

Items Found In the “Remarks” Column

Serial Numbers-Where indicated, this indicates a serial number range (inclusive) where a particular part is used.

Model Number-Where indicated, this shows that the corresponding part is utilized only with this specific model number or model number variant.

Items Found In the “Items Number” Column

All parts with same symbol in the number column, *, #, +, %, or ■, belong to the same assembly or kit.

Note: If more than one of the same reference number is listed, the last one listed indicates newest (or latest) part available.

MODULAR LIGHT TOWER — SPARE PARTS

MODULAR LIGHT TOWER 1 TO 3 UNITS

Qty.	P/N	Description
2	64167441	CLAMP, LIGHT
2	64167100	GASKET, LENS
2	64167744	LENS (GLASS)
2	19823	SUPPORT, TOP LAMP 1000W
2	M1000U	BULB
2	C4403590	REFLECTOR, REAR (OLD STYLE)
2	4105012	REFLECTOR, -(NEW STYLE)
1	3805208	SEAL, RUBBER (OLD STYLE)
1	29156	BALLAST
1	19598	CAPACITOR
1	19999	CIRCUIT BREAKER
1	29098	FAN ASSY.
1	29169	CORD SET
1	363181	SEAL, GREASE
1	363180	BEARING CONE (INNER & OUTER)
1	363913	BEARING CUP (INNER & OUTER)
1	19976	WINCH HANDLE 1500 LB

MODULAR LIGHT TOWER — NAME PLATE AND DECALS

NAME PLATE AND DECALS

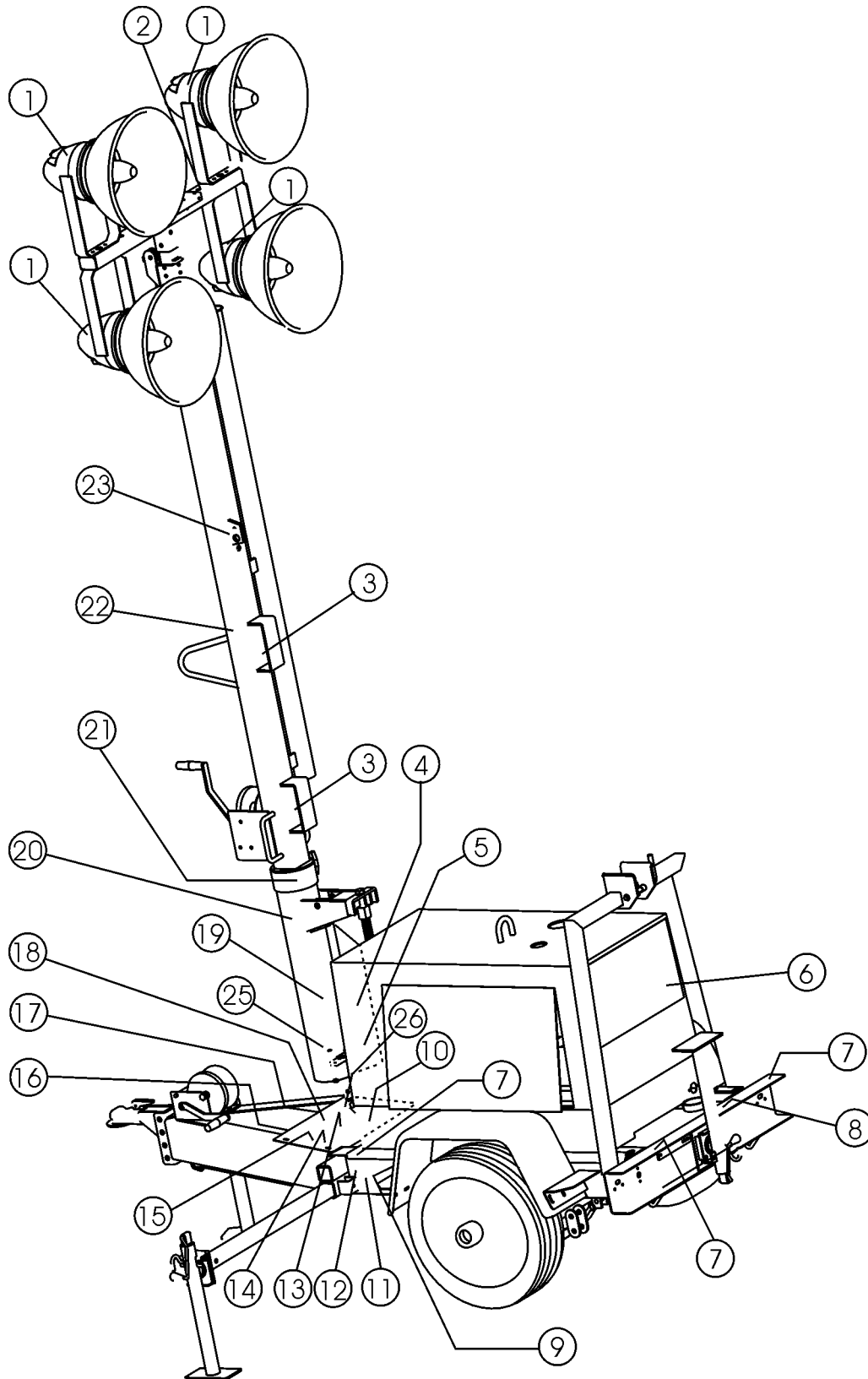

MODULAR LIGHT TOWER — NAME PLATE AND DECALS

NAME PLATE AND DECALS

<u>NO</u>	<u>PART NO</u>	<u>PART NAME</u>	<u>QTY.</u>	<u>REMARKS</u>
1*	B9504000304	DECAL: CAUTION HOT PARTS	4	B90400030
2*	19655	DECAL: DANGER HIGH VOLTAGE	1	
3*	DCL111	DECAL: INSERT FORKS 24"	2	
4*	13118	DECAL: POWDER COATED	1	
5*	DCL109	DECAL: WARNING NON VERT. TOWER	1	
6*	DCL104	DECAL: RING PIN	1	
7*	DCL117	DECAL: SHUT-DOWN GENERATOR	1	
8*	DCL106	DECAL: SWIVEL JACKS	4	
9*	29157	DECAL: DIESEL FUEL	1	
10*	DCL110	DECAL: TIRE PRESSURE	2	
11*	19021	DECAL: TIGHTEN LUG NUTS	2	
12*	DCL102	DECAL: ELECTRICAL SHOCK HAZ.	1	
13		DECAL: NAME PLATE	1 CONTACT MQ SERVICE DEPT. W/ MODEL AND SERIAL NUMBER.
14*	DCL113	DECAL: WARNING TURN OFF LIGHTS	1	
15*	DCL119	DECAL: OPERATING INSTRUCTIONS	1	
16*	DCL112	DECAL: TOWING INSTRUCTIONS	1	
17*	DCL115	DECAL: LIGHT/CONTROL BREAKER	1	
18*	DCL105	DECAL: GROUND LUG	1	
19*	DCL100	DECAL: DANGER HIGH VOLTAGE	1	
20*	DCL120	DECAL: OVERHEAD HAZARD	1	
21*	DCL108	DECAL: STAY CLEAR OF BOOM	1	
22*	DCL116	DECAL: LOOSEN TO TURN	1	
23*	DCL103	DECAL: LIFTING HOOK	2	
24*	DCL118	DECAL: PULL LOCKING PIN	1	
25*	29651	DECAL: DANGER POWER LINES	1	
26*	29425	DECAL: WARNING TOWER STABILITY	1	
26	DCLMLTKIT	KIT, DECAL	1 INCLUDES ITEMS W/ *

SEE DECAL ILLUSTRATIONS ON PAGES 9 AND 10.

MODULAR LIGHT TOWER — MAST ASSEMBLY

TOWER MAST ASSY.

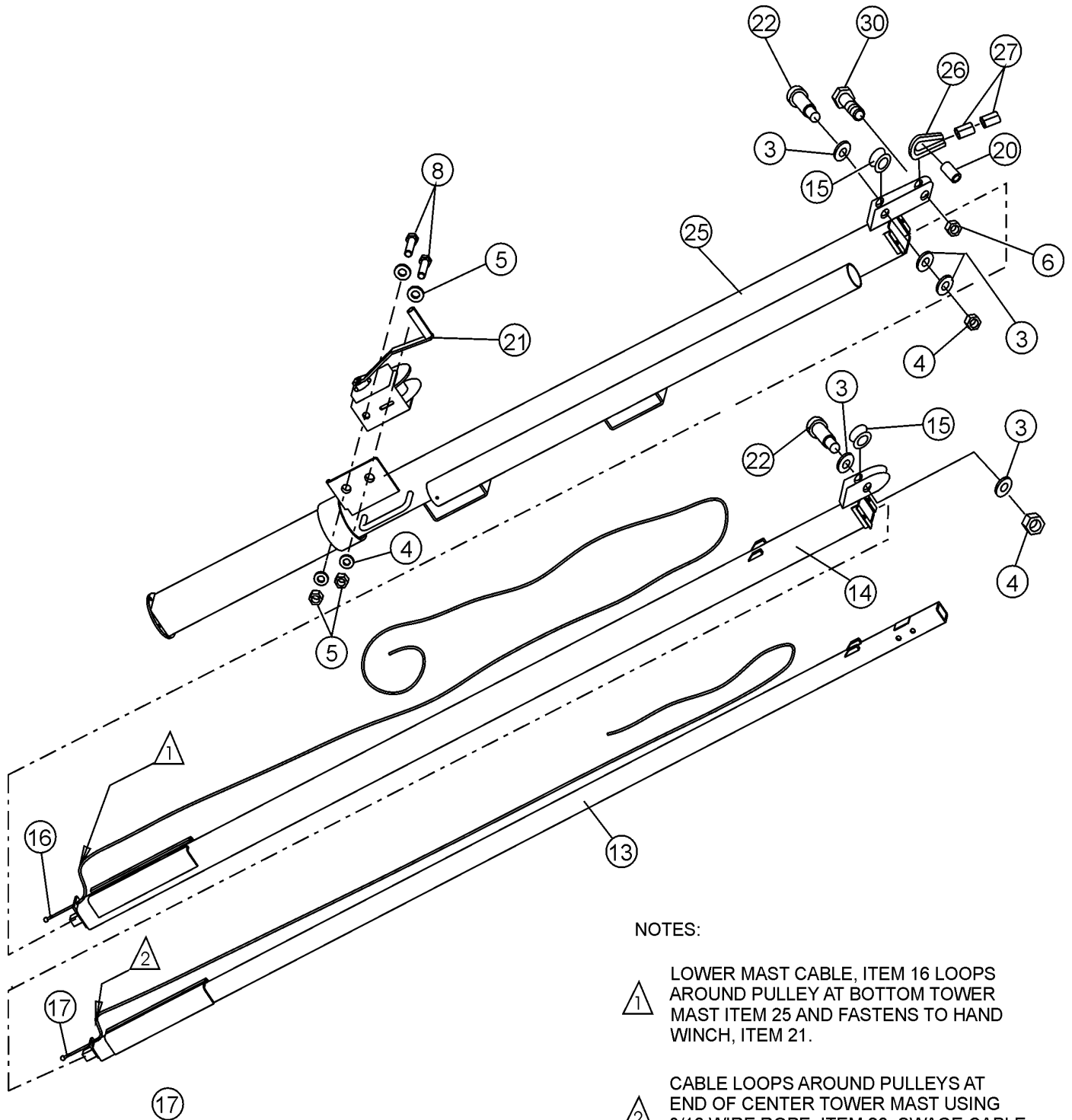

NOTES:



LOWER MAST CABLE, ITEM 16 LOOPS AROUND PULLEY AT BOTTOM TOWER MAST ITEM 25 AND FASTENS TO HAND WINCH, ITEM 21.



CABLE LOOPS AROUND PULLEYS AT END OF CENTER TOWER MAST USING 3/16 WIRE ROPE, ITEM 26. SWAGE CABLE INTO ITEM 27

MODULAR LIGHT TOWER — MAST ASSEMBLY

TOWER MAST ASSY.

<u>NO</u>	<u>PART NO</u>	<u>PART NAME</u>	<u>QTY.</u>	<u>REMARKS</u>
3	0447	WASHER, FLAT 1/2 SAE	7	
4	10133	NUT NYLOC 3/8-16	8	
6	10176	NUT, NYLOC 1/2-13	1	
8	1284	SCREW, HHC 3/8-16 x 1-1/2	2	
13	19923	MAST, TOP TOWER W/A	1	
15	19157	PULLEY, CABLE	2	
14	19920	MAST, CENTER TOWER W/A	1	
16	19939	CABLE, LOWER MAST 231"	1	
17	19938	CABLE UPPER MAST 140"	1	
20	19251	SPACER, 5/8 x 1/2 x 9/16 LONG	1	
22	194975	BOLT SHOULDER 1/2 x 1-1/4	2	
21	19976	WINCH, HAND 1500 LB	1	
25	19910	MAST, BOTTOM TOWER W/A	1	
26	19611	THIMBLE, WIRE ROPE 3/16	1	
27	19973	SWAGE, AL, WIRE ROPE 3/16	1	
30	3242	SCREW, HHC 1/2-13 x 1-3/4	1	

MODULAR LIGHT TOWER — WINCH ASSY.

WINCH ASSY.

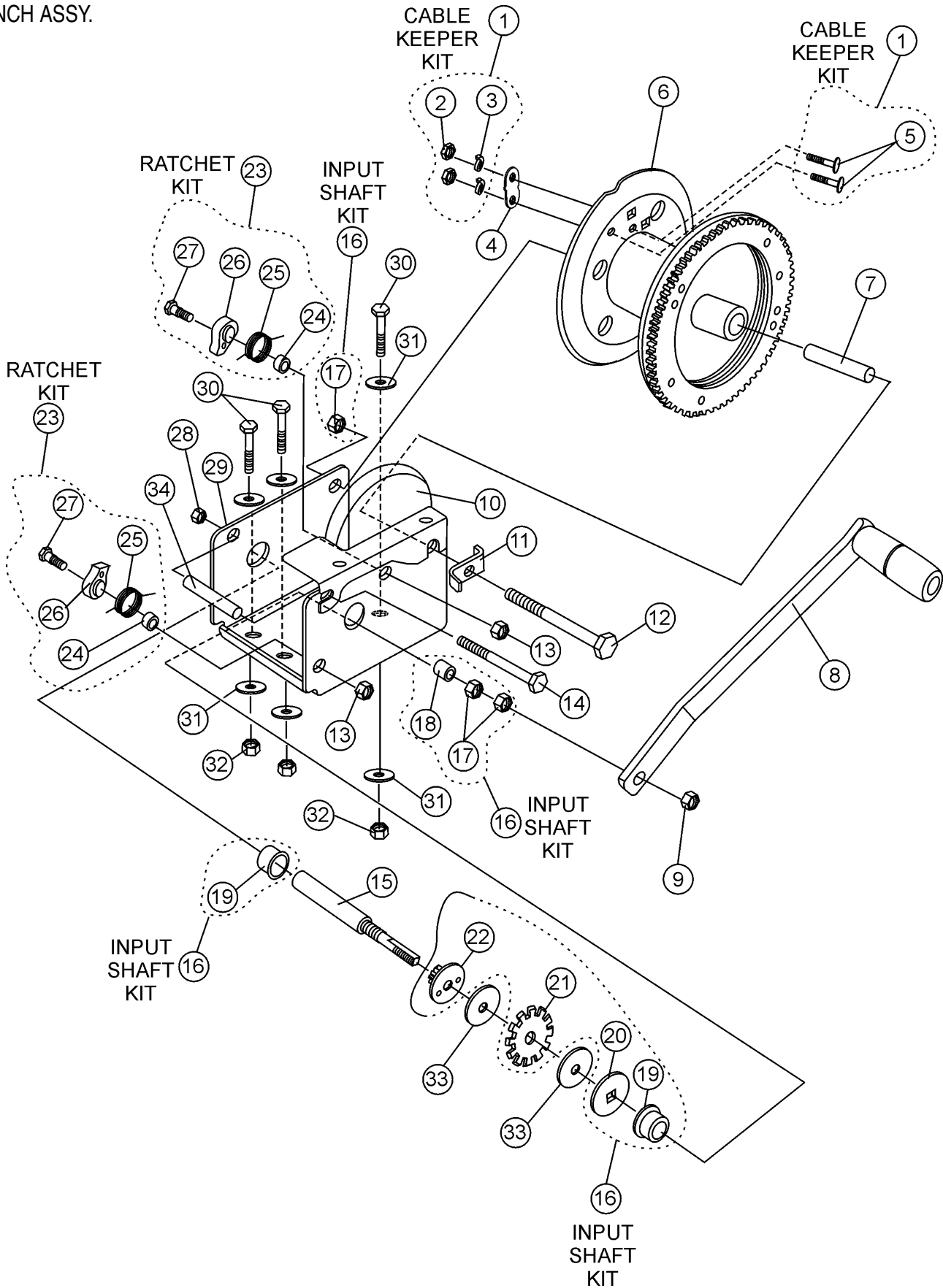

MODULAR LIGHT TOWER — WINCH ASSY.

WINCH ASSY.

<u>NO</u>	<u>PART NO</u>	<u>PART NAME</u>	<u>QTY.</u>	<u>REMARKS</u>
1	562101	CABLE KEEPER KIT	2	INCLUDES ITEM W/*
2*		NUT	2	
3*		WASHER, LOCK	2	
4*		CABLE CLAMP	1	
5*		CARRIAGE BOLT	2	
6		DRUM ASSY.	1	SEE NOTE 1 BELOW
7		DRUM SPACER	1	SEE NOTE 1 BELOW
8	29206	HANDLE ASSY.	1	
9		LOCK NUT 1/2-13	1	STD. HDW. PURCHASE LOCALLY
10	12124S01	COVER ASSY	1	
11		BOLT LOCK	1	SEE NOTE 1 BELOW
12		CAP SCREW 1/2-13	1	STD. HDW. PURCHASE LOCALLY
13%		LOCK NUT	2	
14		CAP SCREW 3/8-16	1	STD. HDW. PURCHASE LOCALLY
15	1564S01	INPUT SHAFT	1	
16	1563S01	INPUT SHAFTKIT	1	INCLUDES ITEM W/#
17#		LOCK NUT 1/2-13	3	
18#		SPACER	1	
19#		BUSHING	2	
20#		SHAFT BRAKE DISC	1	
21#		RATCHET GEAR	1	
22#		PINION AND DISC	1	
23	6730S00	RATCHET KIT	2	INCLUDES ITEMS W/%
24%		RATCHET SPACER	2	
25%		RATCHET SPRING	2	
26%		RATCHET PAWL	2	
27%		SHOULDER BOLT 5/16-18	2	
28		LOCK NUT 3/8-16	1	STD. HDW. PURCHASE LOCALLY
29		FRAME	1	SEE NOTE 1 BELOW
30	1284	SCREW, HHC 3/8-16 X 1-1/2	3	
31	10136	WASHER, FLAT 3/8 SAE	6	
32	10133	NUT, NYLOC 3/8-16	3	
33	1558S00	FRICTION DISC KIT	2	
34		FRAME SPACER	1	SEE NOTE 1 BELOW
35	19976	HAND WINCH 1200 LBS.	1	COMPLETE ASSEMBLY

NOTES:

1. SOLD ONLY AS A COMPLETE ASSEMBLY. USE PART NUMBER 19976 WHEN ORDERING.

MODULAR LIGHTTOWER — FLOODLIGHT MOUNTING ASSY.

FLOODLIGHT MOUNTING ASSY.

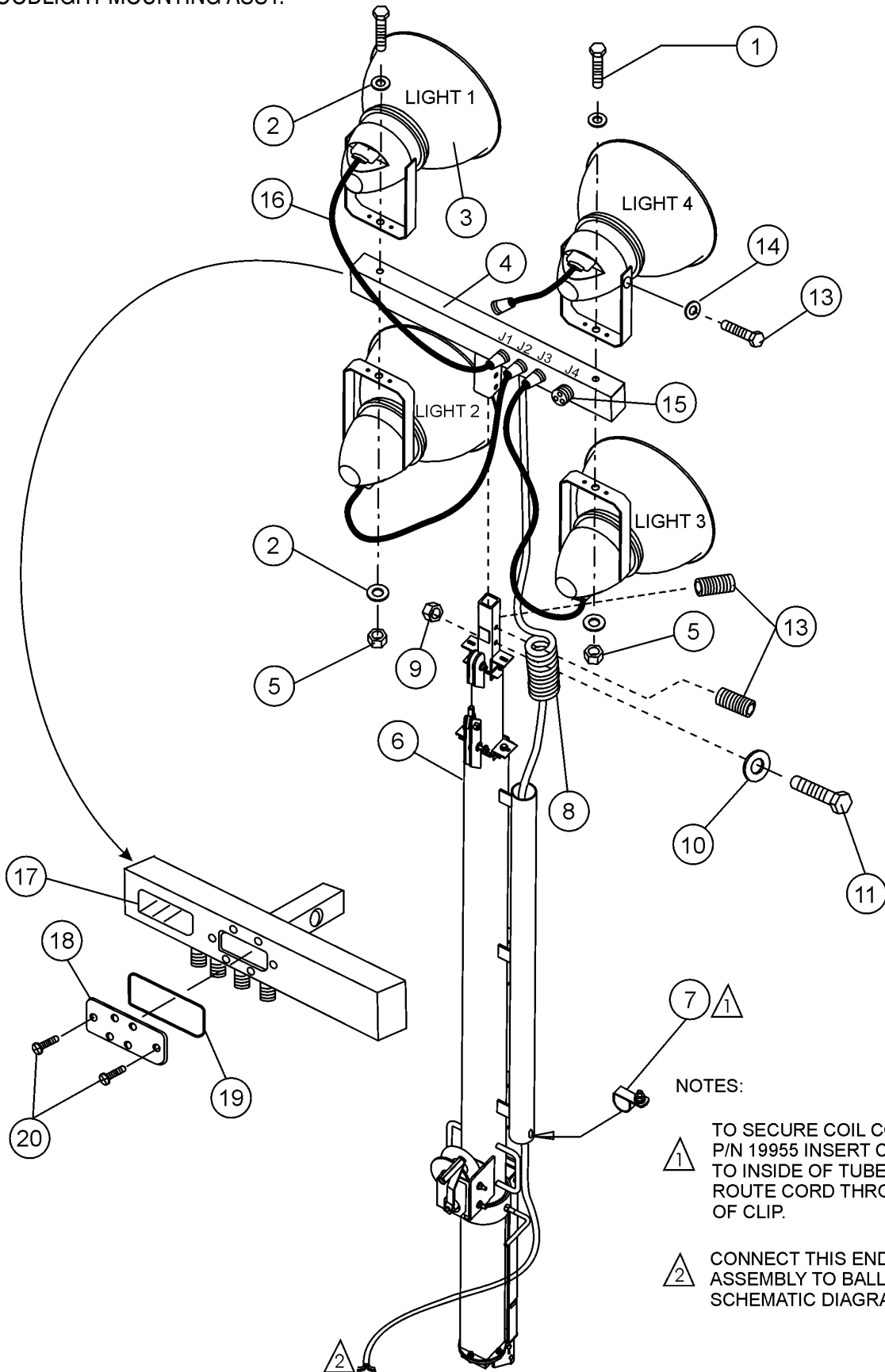

MODULAR LIGHTTOWER — FLOODLIGHT MOUNTING ASSY.

FLOODLIGHT MOUNTING ASSY.

<u>NO</u>	<u>PART NO</u>	<u>PART NAME</u>	<u>QTY.</u>	<u>REMARKS</u>
1	19249	SCREW, HHC 3/4-16 x 4	2	
2	5079	FLAT WASHER, 3/4	4	
3	29174	FLOOD LIGHT, ASSY.	4	
4	19940	MOUNT, LIGHT FIXTURE W/A	1	
5	19250	NUT, NYLOC 3/4-16 x 4	2	
6	19956	TOWER MASTS, ASSY.	1	
7	11505	CLIP, CABLE	2	
8	19955	LEAD ASSY., TOWER WIRING	1	
9	10176	NUT, NYLOC 1/2-13	1	
10	0447	WASHER, FLAT, 1/2 SAE 2	2	
11	3215	SCREW, HHC 1/2-13 X 3-1/2	1	
12	16786	SCREW, SH 1/2-13 X 3/4	2	
13	29161	SCREW, HHC 1/2-13 X 1 SS	2	
14	29162	WASHER, HS 1/2 SS	2	
15	29042	RECEPTACLE, FEMALE (J1,J2,J3 & J4)	4	
16	29169	POWER CORD SET (MALE)	4	
17	19972	REFLECTOR, RED	1	
18	19945	PLATE, COVER	1	
19	19944	GASKET, PLATE COVER	1	
20	29046	SCREW, COVER PLATE	1	
21	19688	INSULATOR, SPLICE CAP PLASTIC	6	
22	19687	COPPER SPLICE CAP	6	

MODULAR LIGHT TOWER — LIGHT FIXTURE ASSY.

LIGHT FIXTURE ASSY. S/N 4GNLT1018YB900071 AND BELOW

CONNECT LIGHT FIXTURE WIRING TO JUNCTION BOX, SEE BELOW.

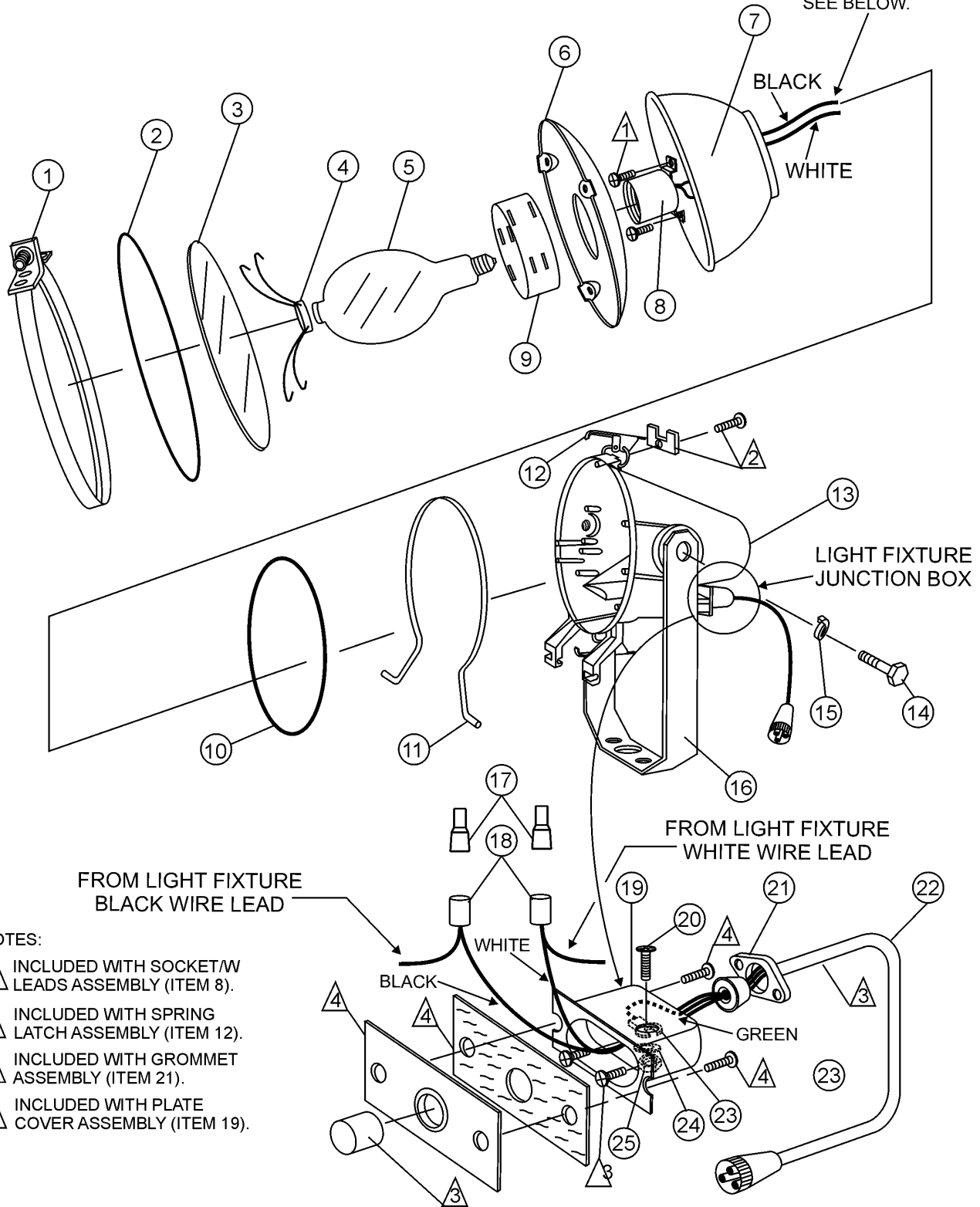

NOTES:

- ① INCLUDED WITH SOCKET/W LEADS ASSEMBLY (ITEM 8).
- ② INCLUDED WITH SPRING LATCH ASSEMBLY (ITEM 12).
- ③ INCLUDED WITH GROMMET ASSEMBLY (ITEM 21).
- ④ INCLUDED WITH PLATE COVER ASSEMBLY (ITEM 19).

MODULAR LIGHT TOWER — LIGHT FIXTURE ASSY.

LIGHT FIXTURE ASSY. S/N 4GNLT1018YB9000721 AND BELOW

<u>NO</u>	<u>PART NO</u>	<u>PART NAME</u>	<u>QTY.</u>	<u>REMARKS</u>
1	64167441	CLAMP, LIGHT	4	
2	64167100	LENS GASKET	4	
3	64167744	LENS	4	
4	19823	SUPPORT, TOP LAMP 1000 WATT	4	
5	M1000U	BULB	4	
6	C4403590	REFLECTOR, REAR	4	
7	64167238	REFLECTOR (WITHOUT GLASS)	4	
8	A4605079	SOCKET W/LEADS	4	
9	C4310161	REFLECTOR, SIDE	4	
10	3805208	FIXTURE SEAL, RUBBER	4	
11	4402155	HOLDER	4	
12	94887	SPRING LATCH ASSEMBLY	4	
13	B4300015	FIXTURE HOUSING	4	
14	29161	SCREW, HHC 1/2-13 X 1 SS	8	
15	29162	WASHER, HS 1/2 SS	8	
16	29163	TRUNION (YOKE)	4	
17	19688	INSULATOR, SPLICE CAP (PLASTIC)	8	
18	19687	COPPER SPLICE CAP	8	
19	A4300250	PLATE COVER ASSY.	4	
20	1006MPP188	SCREW, 10 X 24 PAN HEAD 3/8 SS	4	
21	3805199	GROMMET ASSY.	4	
22	29169	CORD SET MOLDED	4	
23	1272	TERMINAL, SPADE 16-14 #8 INSUL.	4	
24	10NF88	NUT, HEX 10-24	4	
25	10237	WASHER, EXT.SHKP. #10	4	
26		FLOOD LIGHT ASSY.	1 THIS FLOODLIGHT ASSEMBLY HAS BEEN DISCONTINUED. USE P/N 29174 WHEN RE-ORDERING. HOWEVER COMPONENTS FOR THE OLD STYLE FLOOD LIGHT CAN STILL BE ORDERED.

MODULAR LIGHT TOWER — LIGHT FIXTURE ASSY.

LIGHT FIXTURE ASSY. S/N 4GNLT1018YB900072 AND ABOVE

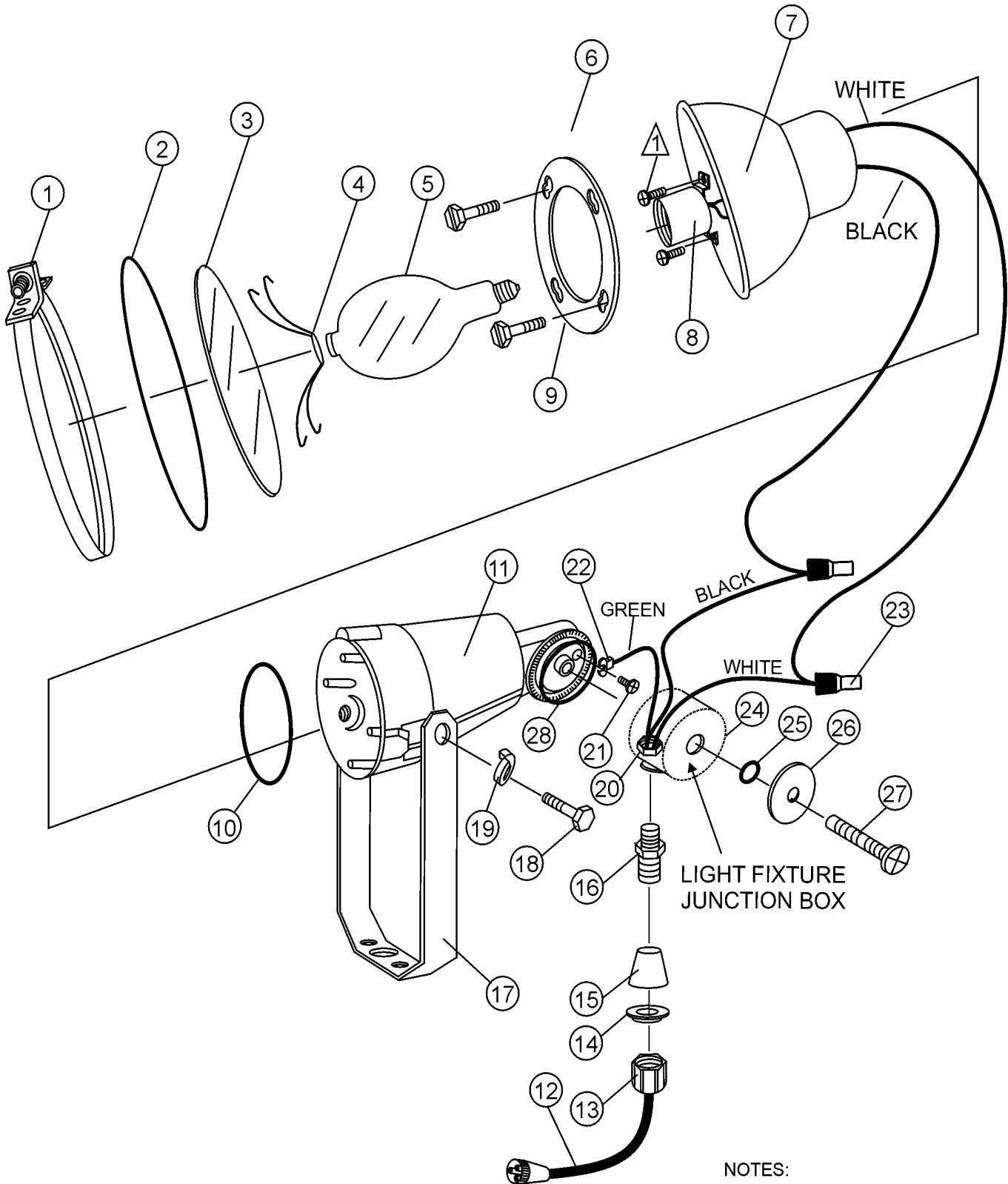

NOTES:

△ INCLUDED WITH SOCKET/W
LEADS ASSEMBLY (ITEM 8).

MODULAR LIGHT TOWER — LIGHT FIXTURE ASSY.

LIGHT FIXTURE ASSY. S/N 4GNLT1018YB900072 AND ABOVE



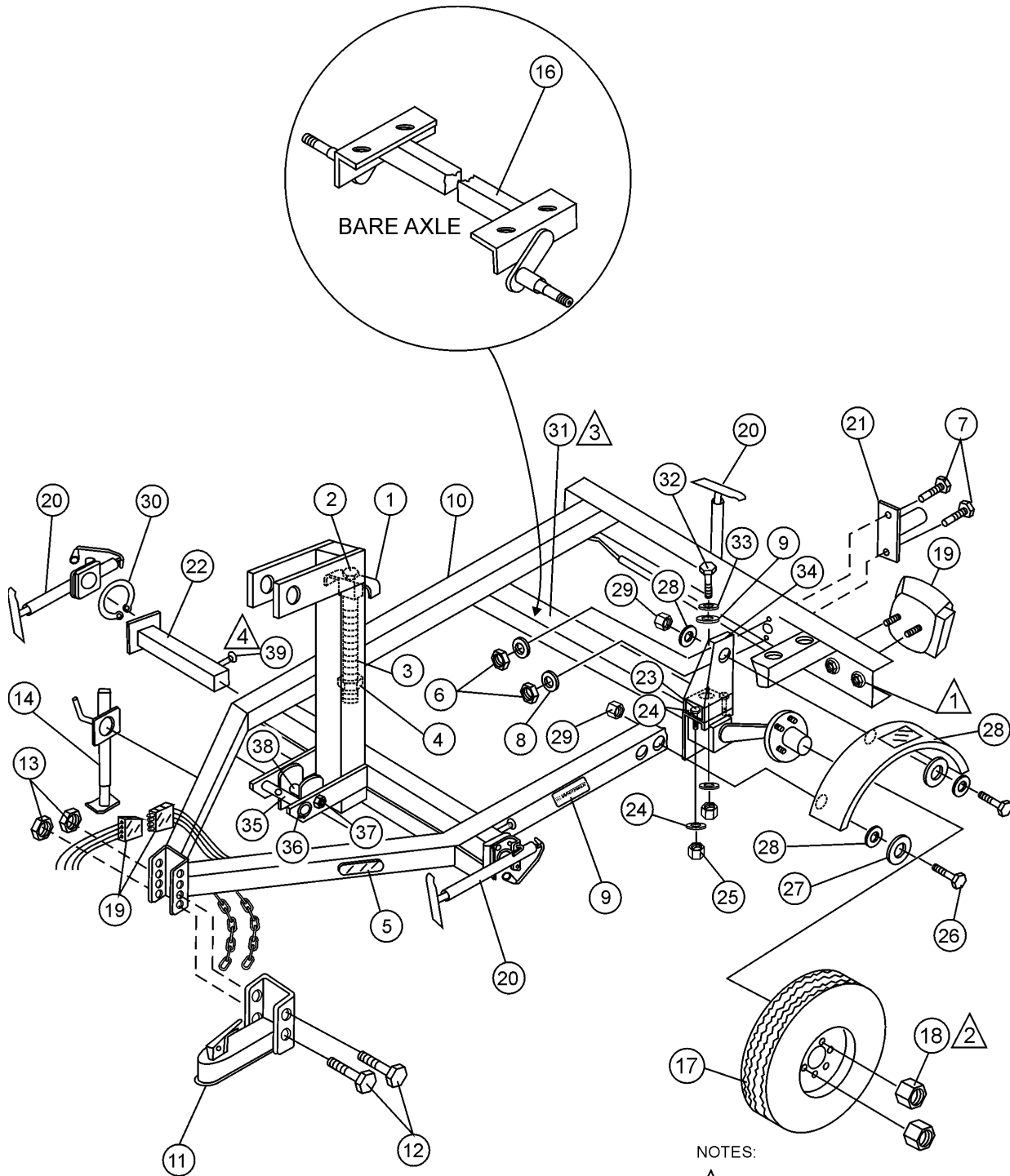

<u>NO</u>	<u>PART NO</u>	<u>PART NAME</u>	<u>QTY.</u>	<u>REMARKS</u>
1 *	64167441	CLAMP, LIGHT	4	
2 *	64167100	LENS GASKET	4	
3 *	64167744	LENS (GLASS)	4	
4 *	19823	SUPPORT, TOP LAMP 1000 WATT	4	
5 *	M1000U	BULB	4	
6 *	4101024	REINFORCING RING	1	
7 *	4105012	REFLECTOR (WITHOUT GLASS)	4	
8*	4605079000	SOCKET 4KV MONGUL LEADS	4	
9 *	70463	SCREW, 10-24 X 5/8 BLACK	16	
10*	2450120	GASKET, HOUSING/REFLECTOR	4	
11*	3100056	FIXTURE HOUSING	4	
12 *	29169	CORD SET MOLDED	4	
13 *	4110624000	WASHER, 1/2 EXT. TOOTH SS	4	
14 *	6900446	SEAL RING .755 ID	4	
15 *	6900447	STRAIN RELIEF	4	
17 *	4101021	TRUNION (YOKE)	4	
18 *	63960	SCREW, HHCS 1/2-13 X 1-1/4	4	
19 *	29162	WASHER, LOCK HS 1/2 SS	4	
20 *	5232GR	STRAIGHT CONNECTOR 1/2"	4	
21 *	4107742000	SCREW, 6-32 X 3/8	4	
22 *	2856	TERMINAL, SPADE 16-14#8 INSUL.	4	REPLACES 1272
23 *	19688	INSULATOR, SPLICE CAP (PLASTIC)	4	
24 *	4100003	CONNECTION BOX	4	
25 *	2450121	O-RING .206" X 1.03" SILICON	4	
26 *	6351110	WASHER, 1/4 X 1-1/4 OD X .63 GALV.	4	
27 *	6301045	SCREW, 1/4-20 X 2" PH PH SS	4	
28 *	2450119	O-RING, 1.925" ID X 1.03"	4	
29 *	4106781000	SCREW, 8-32 X 3/8 PH PH	8	
30 *	4104021000	POP RIVET 1/8 X 3/16 DOMED AL	8	
31 *	4101023	BRACKET, SOCKET	4	
32	29174	LIGHT FIXTURE ASSY.	1	INCLUDES ITEMS W/*

MODULAR LIGHT TOWER — TRAILER ASSY.

TRAILER ASSY.



NOTES:

-  INCLUDED WITH LIGHT KIT P/N 9510.
-  TORQUE LUG NUTS PER LUG NUT TORQUE TABLE REFERENCED IN THIS MANUAL.
-  SEE PAGES 58 AND 59 FOR COMPLETE AXLE ASSEMBLY.
-  INCLUDES WASHER, SPRING AND COTTER PIN.

MODULAR LIGHT TOWER — TRAILER ASSY.

TRAILER ASSY.

<u>NO.</u>	<u>PART NO.</u>	<u>PART NAME</u>	<u>QTY.</u>	<u>REMARKS</u>
1	29020	THRUST PLATE - SPRING	1	
2	29077	SCREW, HHC 5/8 - 11 X 9 1/2	1	
3	19989	SPRING, TOWER	1	
4	9503	NUT, NYLOC 5/8 - 11	1	
5	29158	REFLECTOR, AMBER	2	
6	10024	NUT, NYLOC 1/4 - 20	2	
7	0730	SCREW, HHC 1/4 - 20 X 1	2	
8	0948	WASHER, FLAT 1/4	2	
9		SERIAL NUMBER PLATE	1	CONTACT MQ SERVICE DEPT. W/ MODEL AND S/NUMBER
10	19904	FRAME	1	
11	19102	COUPLER	1	
12	9502	SCREW, HHC 5/8 - 11 X 4 1/2 #8	2	
13	9503	NUT, NYLOC 5/8 - 11	2	
14	29095	JACK, SIDEWIND	2	
15	29074	FENDER ASSEMBLY	2	
16	29212	AXLE MLT TORSION (BARE)	1	
17	19045	TIRE & WHEEL ASSEMBLY	2	
18	8115	NUT, WHEEL 1/2 - 20 60 CORE	10	
19	9510	KIT, LIGHT - TRAILER	1	
20	19525	JACK, TOP WIND	2	
21	9514	LIGHT ASSY. LICENSE PLATE	1	
22	19948	OUTRIGGER	2	
23	16524	SCREW, HHC 1/2 - 13 X 1 1/4 GD8	4	
24	16630	WASHER, FLAT 1/2 SAE HS	8	
25	16629	NUT, NYLOC 1/2 - 13 GD8	4	
26	0205	SCREW, HHC 3/8 - 16 X 1	8	
27	3233	WASHER, FENDER 3/8	8	
28	10136	WASHER, FLAT 3/8	8	
29	10133	NUT, NYLOC 3/8 - 16	8	
30	19527	SNAP RING	4	
31	29067	AXLE ASSEMBLY (COMPLETE)	1	SEE PAGES 60 AND 61
32	0131A	SCREW, HHC 1/4-20 X 3/4	1	
33	0181B	WASHER, LOCK, 1/4 MED	1	
34	29101	BRACKET, SUPPORT FENDER	1	
35	29008	ROLL PIN, CABLE	1	
36	1135	RING, SNAP	1	
37	10176	NUT, NYLOC LOCK 1/2-13	1	
38	29017	SCREW, HHC 1/2-13 X 5-1/2	1	
39	29211	PIN ASSY, LATCH	3	

MODULAR LIGHTTOWER — AXLE ASSY.

AXLE ASSY.

AXEL ASSEMBLY
SEE PAGES 58 AND 59.

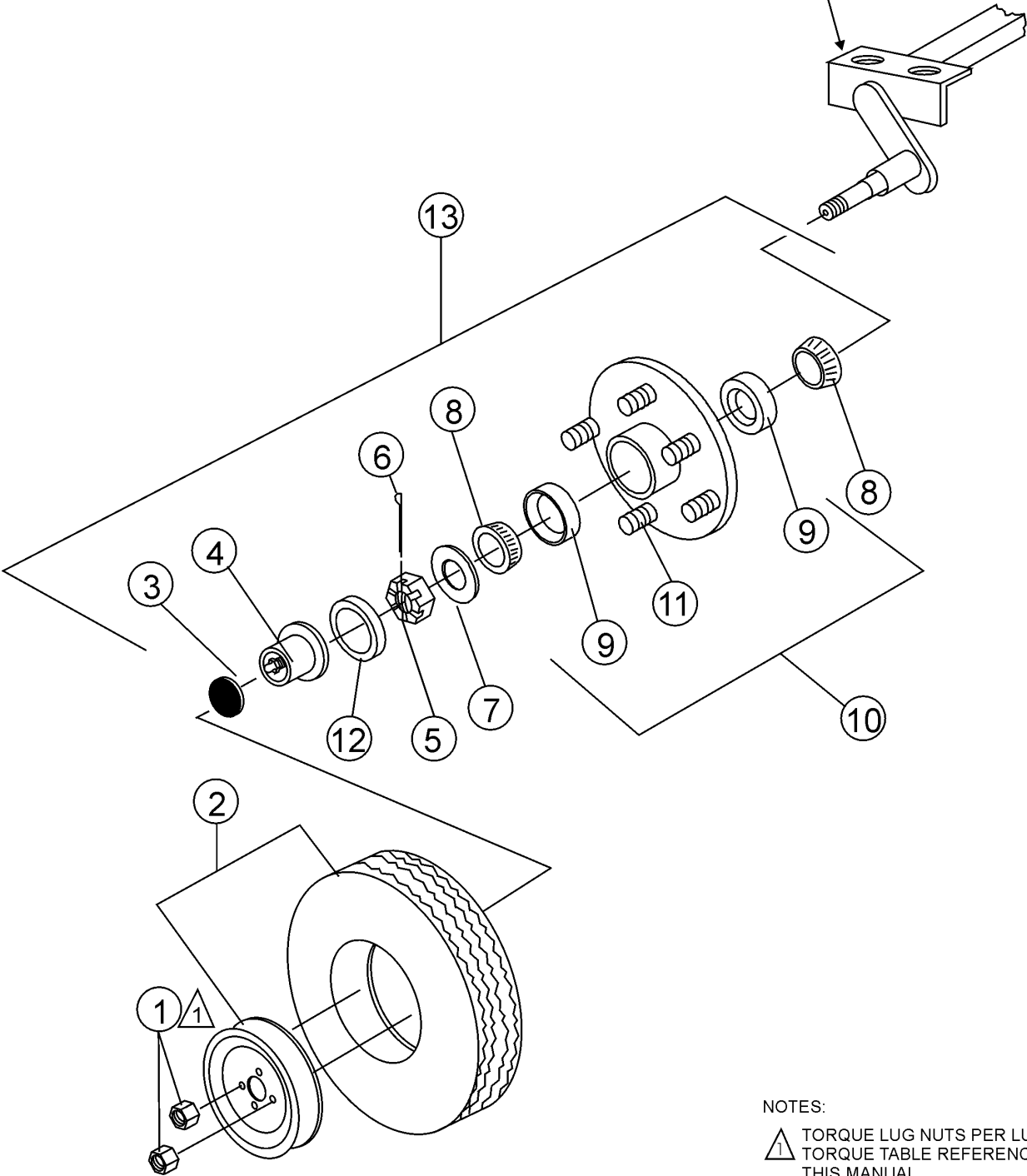

MODULAR LIGHT TOWER — AXLE ASSY.

AXLE ASSY.

<u>NO.</u>	<u>PART NO.</u>	<u>PART NAME</u>	<u>QTY.</u>	<u>REMARKS</u>
1	8115	NUT, LUG 1/2 - 20 60° CONE	10	
2	19045	WHEEL & TIRE ASSY.	2	
3#	568067	RUBBER PLUG (AG)	2	
4#	363277	GREASE CAP (AG)	2	
5#	363257	SPINDLE NUT 1"-1/4	2	
6#	363258	COTTER PIN	2	
7#	363259	WASHER, SPINDLE	2	
8#	363180	BEARING CONE (INNER & OUTER)	4	
9*	363913	BEARING CUP (INNER & OUTER)	4	
10	363188	HUB ASSY., IDLER	2	INCLUDES ITEMS W/*
11*#	363908	STUD, 1/2"-20	10	
12#	363275	SEAL, GREASE	2	
13	29067	AXLE ASSY. (COMPLETE)	1	INCLUDES ITEMS W/#

MODULAR LIGHT TOWER — FUEL TANK ASSY.

FUEL TANK ASSY.

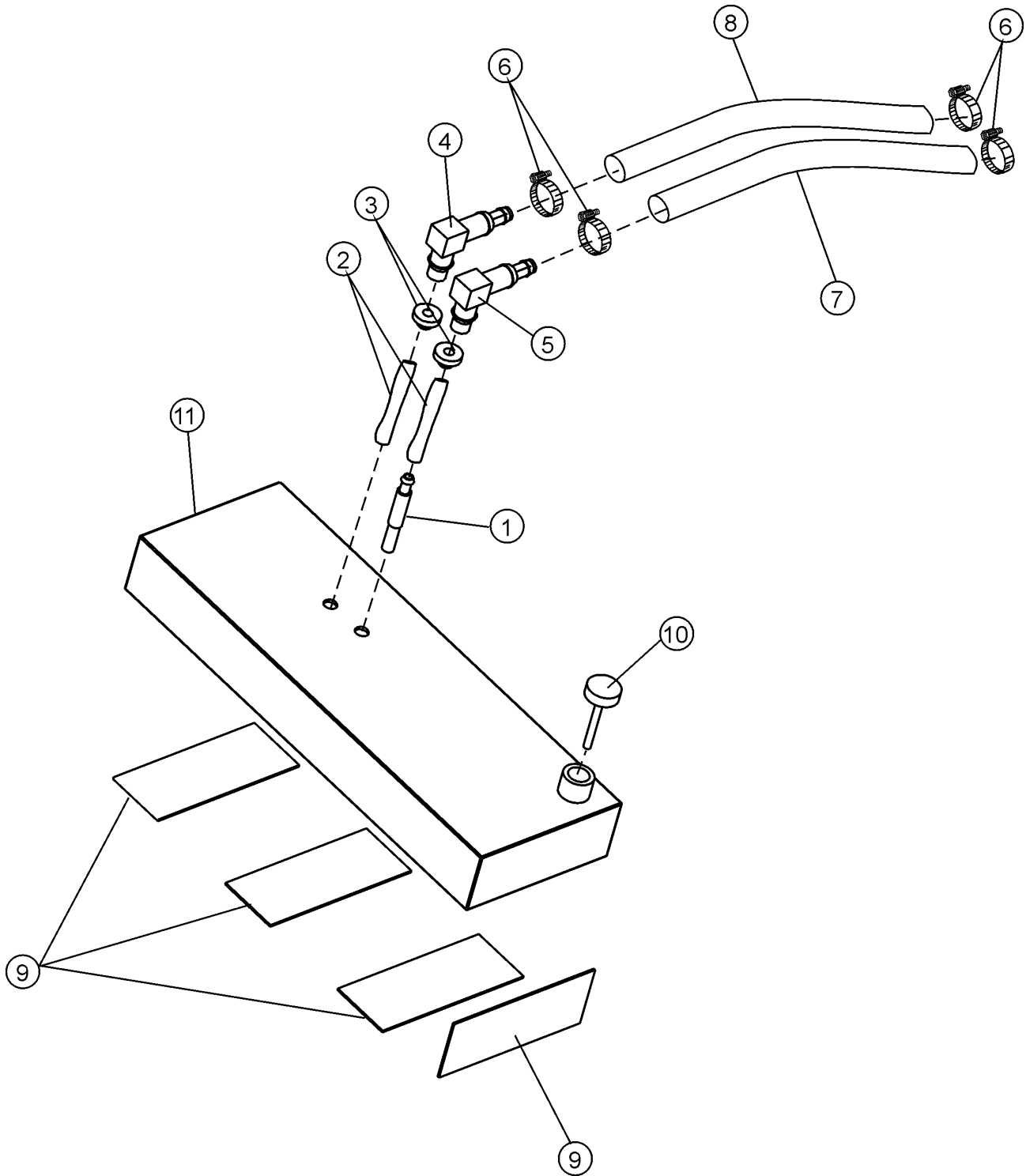

MODULAR LIGHT TOWER — FUEL TANK ASSY

FUEL TANK ASSY.

<u>NO</u>	<u>PART NO</u>	<u>PART NAME</u>	<u>QTY.</u>	<u>REMARKS</u>
1	12008	SCREEN, FILTER	1	
2	60058	HOSE.375 0D X .25 ID PVC FUEL YELLOW, 1.0 FT	1	
3	19633	BUSHING, RUBBER FUEL	2	
4	12006	FITTING, 90 03BARB-4BARB FUEL	1	
5	12008	FITTING, 90 FUEL	1	
6	19473	CLAMP, WORM HOSE, #4 (1/4-5/8)	4	
7	60028	HOSE, .312 ID RUBBER FUEL, 1.6 FT. LONG	1	
8	60058	HOSE, .187 ID RUBBER, 2.25 FT. LONG	1	
9	19094	LINER, FUEL TANK	4	
10	19984	CAP, FUEL W/GAUGE (5-3/4)	1	
11	19983	TANK, FUEL	1	

MODULAR LIGHTTOWER — OPTIONAL ELECTRIC FUEL SWITCH ASSY.

OPTIONAL ELECTRIC FUEL SWITCH ASSY. (FUEL TANK)

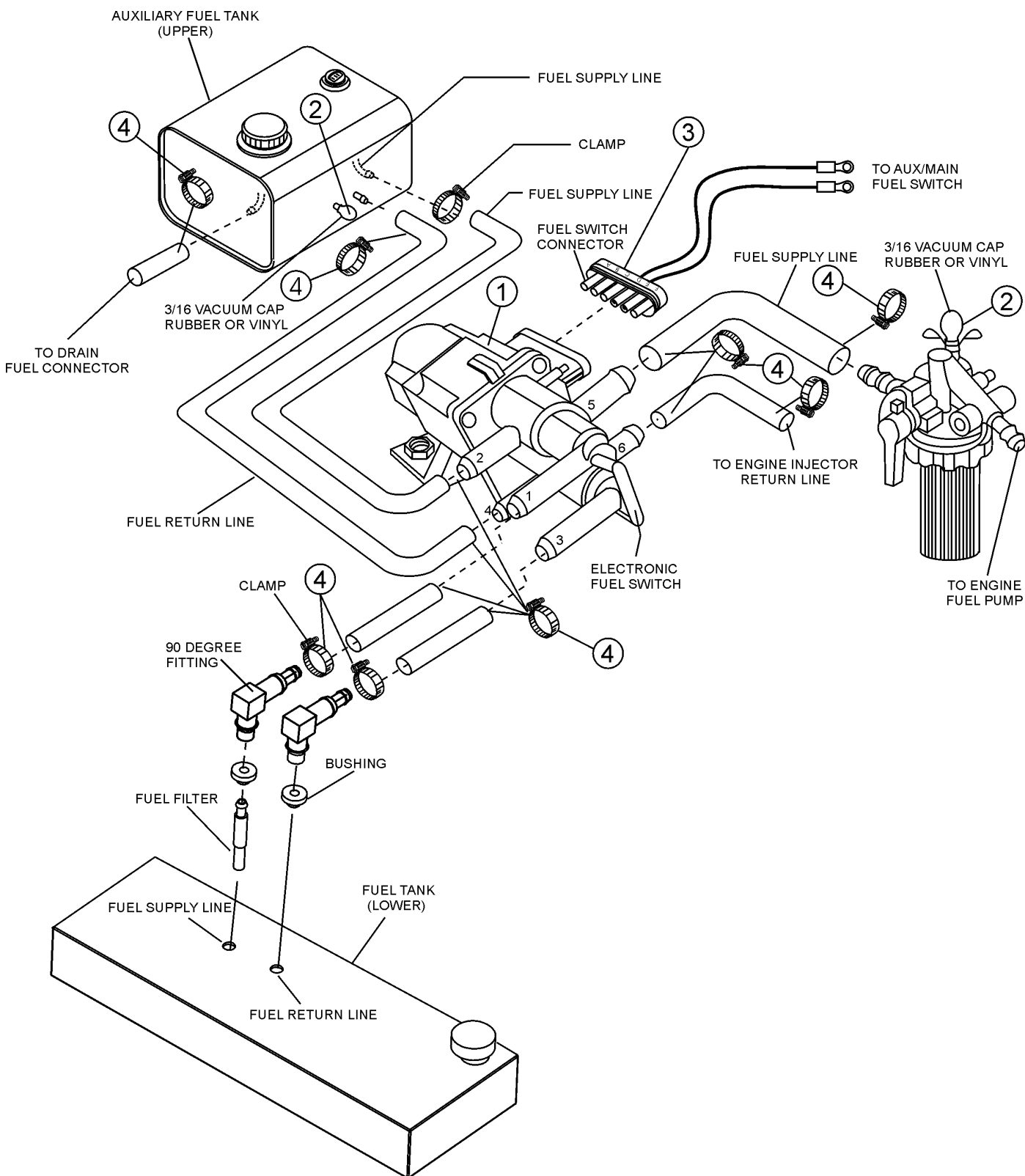

MODULAR LIGHT TOWER — OPTIONAL ELECTRIC FUEL SWITCH ASSY.

OPTIONAL ELECTRIC FUEL SWITCH ASSY. (FUEL TANK)

<u>NO</u>	<u>PART NO</u>	<u>PART NAME</u>	<u>QTY.</u>	<u>REMARKS</u>
1	29164	VALVE, SELECTOR-DC	1 OPTION
2	19870	CAP, VACUUM PLUG	2	
3	29165	CONNECTOR ASSY.-SWITCH	1	
4	19473	CLAMP, HOSE #4	7	

MODULAR LIGHT TOWER — SUPPORT STANDS ASSY.

SUPPORT STANDS ASSY.

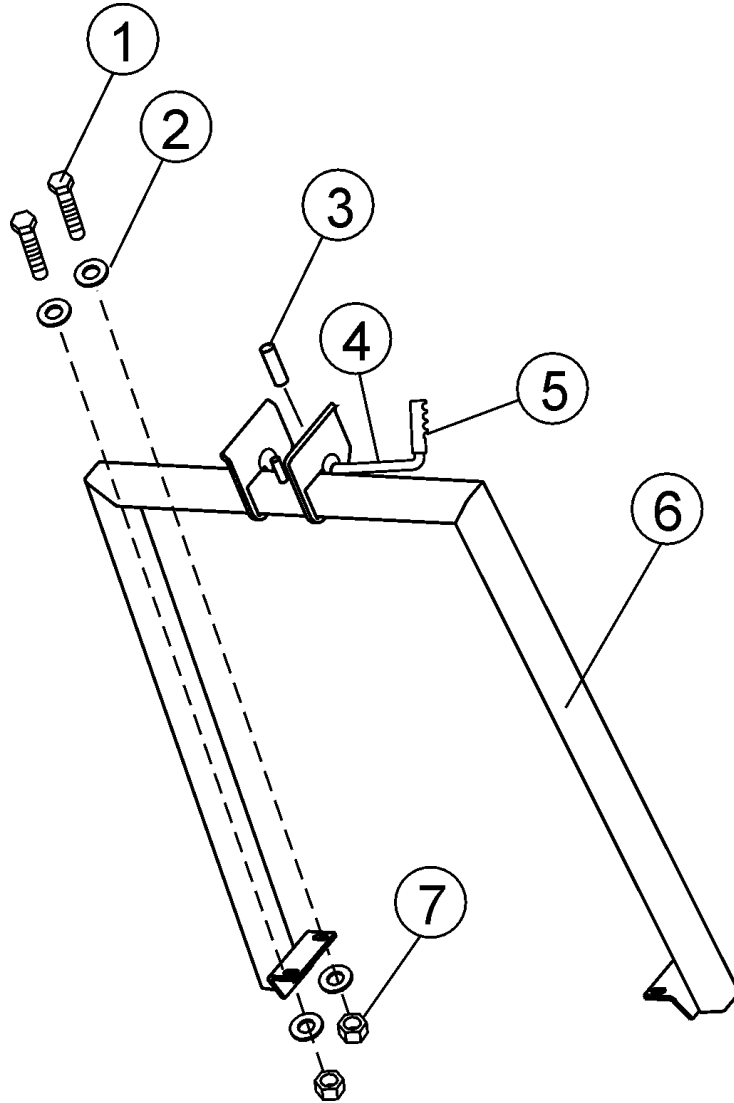

MODULAR LIGHT TOWER — SUPPORT STANDS ASSY.

SUPPORT STANDS ASSY.

<u>NO</u>	<u>PART NO</u>	<u>PART NAME</u>	<u>QTY.</u>	<u>REMARKS</u>
1	1284	SCREW, HHC 3/8-16 X 1-1/2	4	
2	10136	WASHER, FLAT 3/8 SAE	4	
3	10133	NUT, NYLOC 3/8-16	4	
4	19950	PIN, LOCK REAR SUPPORT	1	
5	19997	HANDLE, 5/8 X4 RED	1	
6	19931	SUPPORT, REAR TOWER	1	
7	4022	ROLL PIN 1/4 X 2	1	

MODULAR LIGHT TOWER — GEN/WELDER TRAILER MOUNTING ASSY.

GENERATOR/WELDER TRAILER MOUNTING ASSY.

DA-7000SS GENERATOR

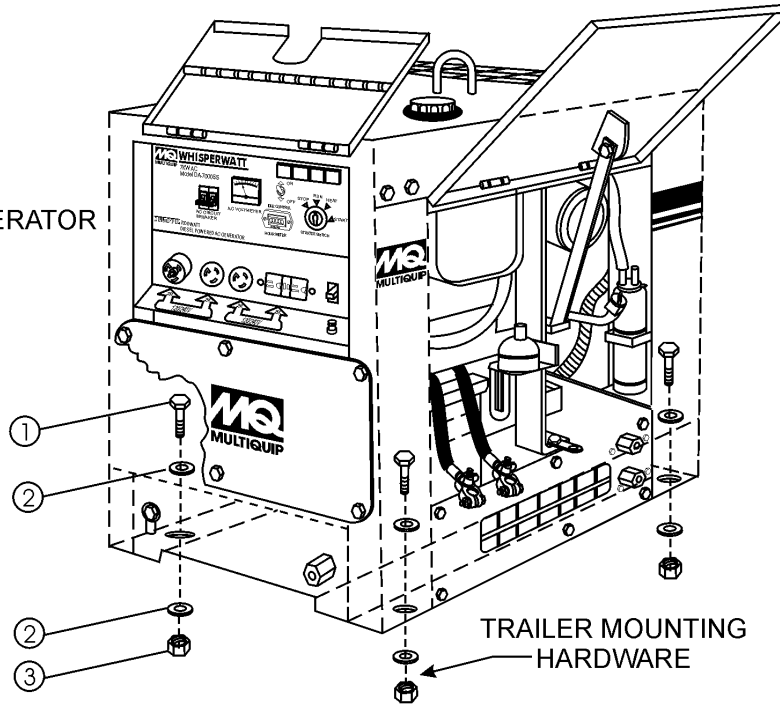

KD1800/KD6 GENERATOR

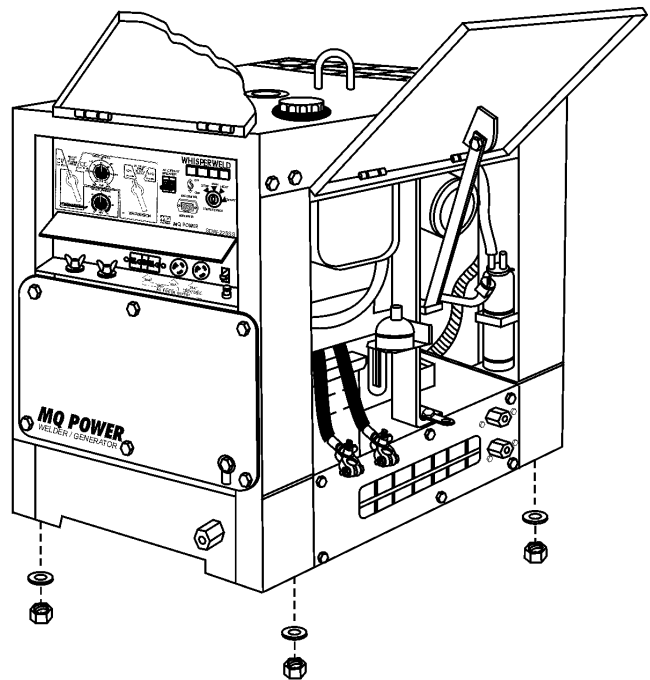
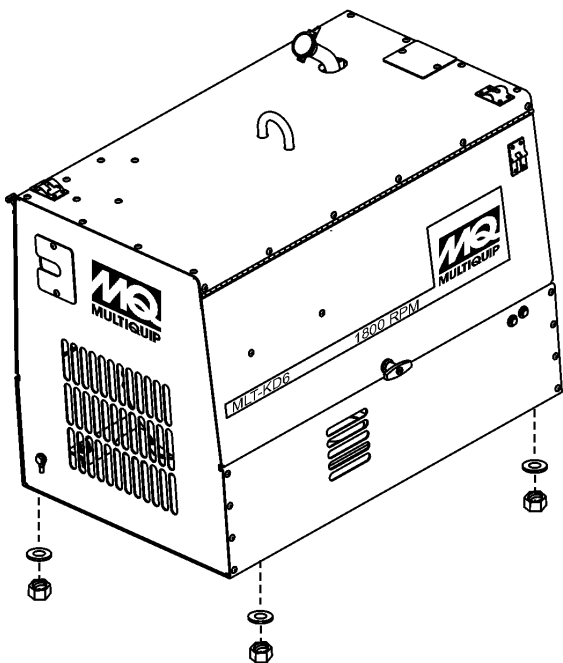

SDW225SS WELDER/GENERATOR

MODULAR LIGHT TOWER — GEN/WELDER TRAILER MOUNTING ASSY.

GENERATOR/WELDER TRAILER MOUNTING ASSY.

<u>NO</u>	<u>PART NO</u>	<u>PART NAME</u>	<u>QTY.</u>	<u>REMARKS</u>
1	5218	SCREW, HHC 1/2-13 X1-1/2	4	
2	0447	WASHER, FLAT 1/2 SAE	8	
3	10176	NUT, NYLOC 1/2-13	4	

MODULAR LIGHT TOWER — COIL CORD ASSY.

COIL CORD ASSY.

CONNECT TO T-BAR ASSEMBLY
(FLOODLIGHTS)

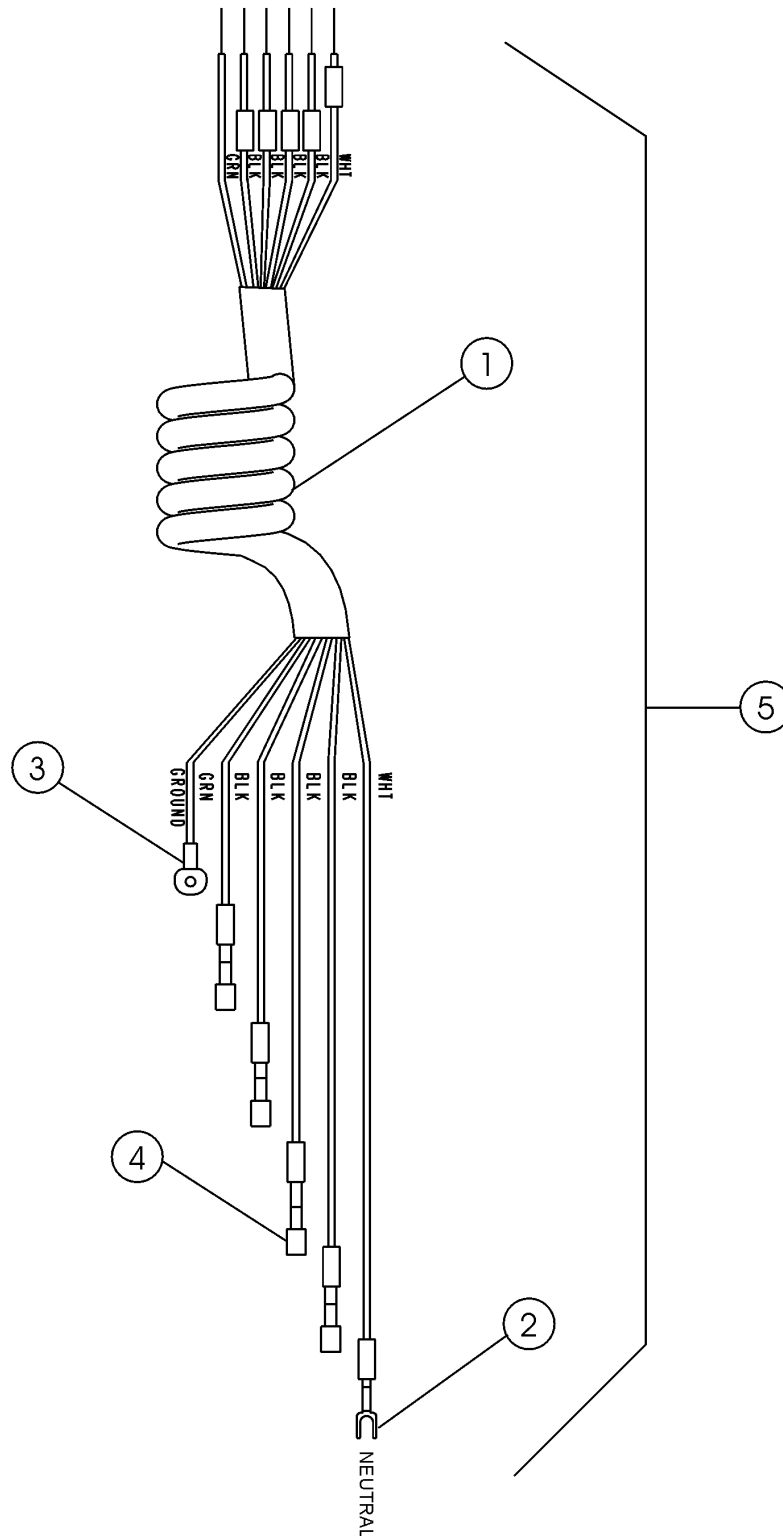

CONNECT TO BALLAST
BOX OUTPUT

MODULAR LIGHTTOWER — COIL CORD ASSY.

COIL CORD ASSY.

<u>NO</u>	<u>PART NO</u>	<u>PART NAME</u>	<u>QTY.</u>	<u>REMARKS</u>
1*	19798	COIL CORD	1	
2*	10104	TERMINAL, SPADE 12-10, #10 INS	1	
3*	3254	TERMINAL, RING 16-14 3/8	1	
4*	11947	TERMINAL, FEM PUSH, 16-14 INSUL	4	
5	19955	COIL CORD ASSY.	1	INCLUDES ITEMS W/*

MODULAR LIGHT TOWER — POWER CABLE ASSY.

POWER CABLE ASSY.

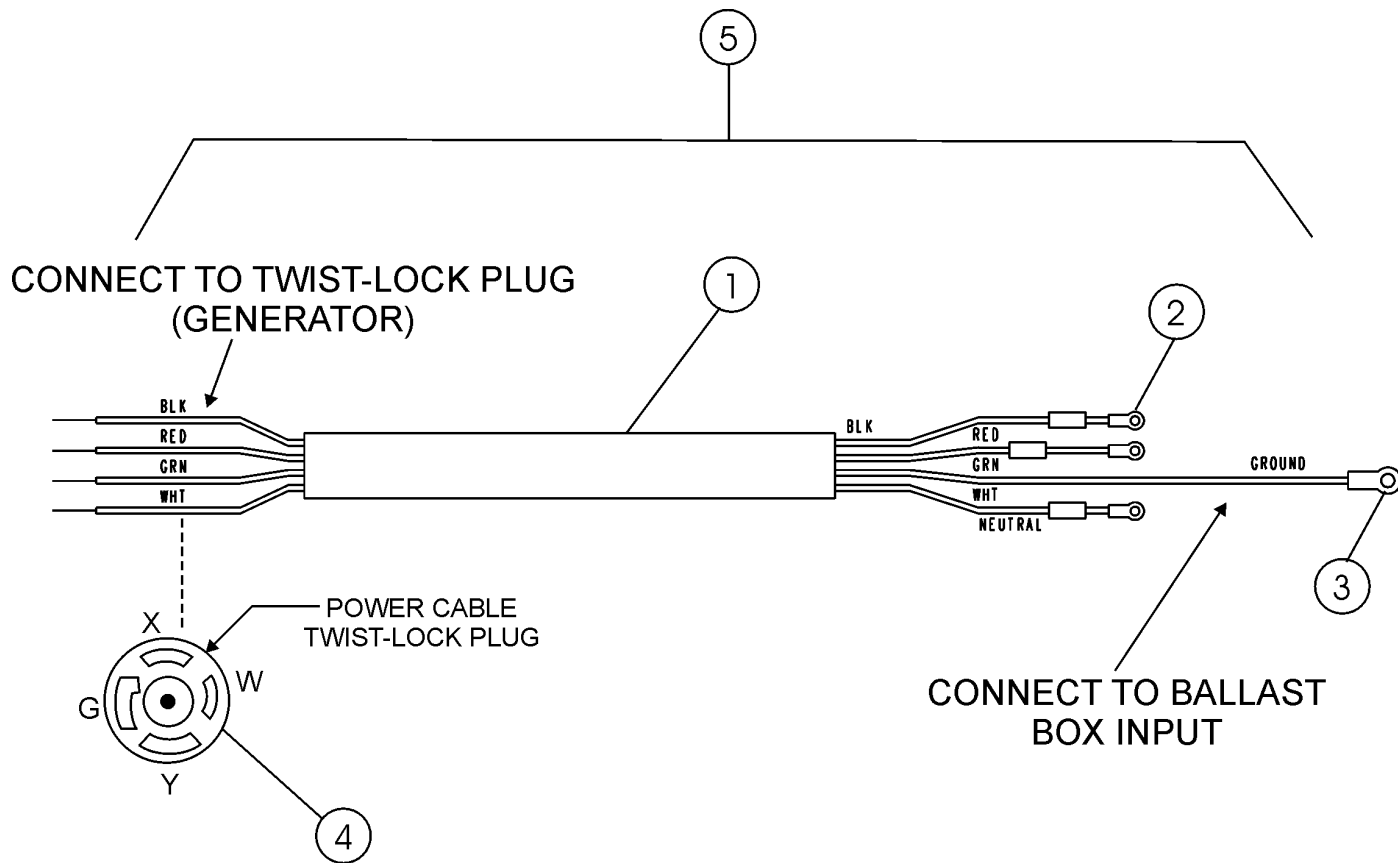

MODULAR LIGHT TOWER — POWER CABLE ASSY.

POWER CABLE ASSY.

<u>NO</u>	<u>PART NO</u>	<u>PART NAME</u>	<u>QTY.</u>	<u>REMARKS</u>
1*	19798	CABLE ELEC 10 AWG X 4	1	COND-600V
2*	10105	TERMINAL, RING 12-10, #10 INS	3	
3*	29069	TERMINAL, RING 10-12AWY X 3/8 IN	1	
4	19686	PLUG, LOCKING	1	P1
5	29068	LEAD ASSEMBLY, POWER	1	INCLUDES ITEMS W/*

MODULAR LIGHTTOWER — BALLAST COMPARTMENT COVER ASSY.

BALLAST COMPARTMENT COVER ASSY.

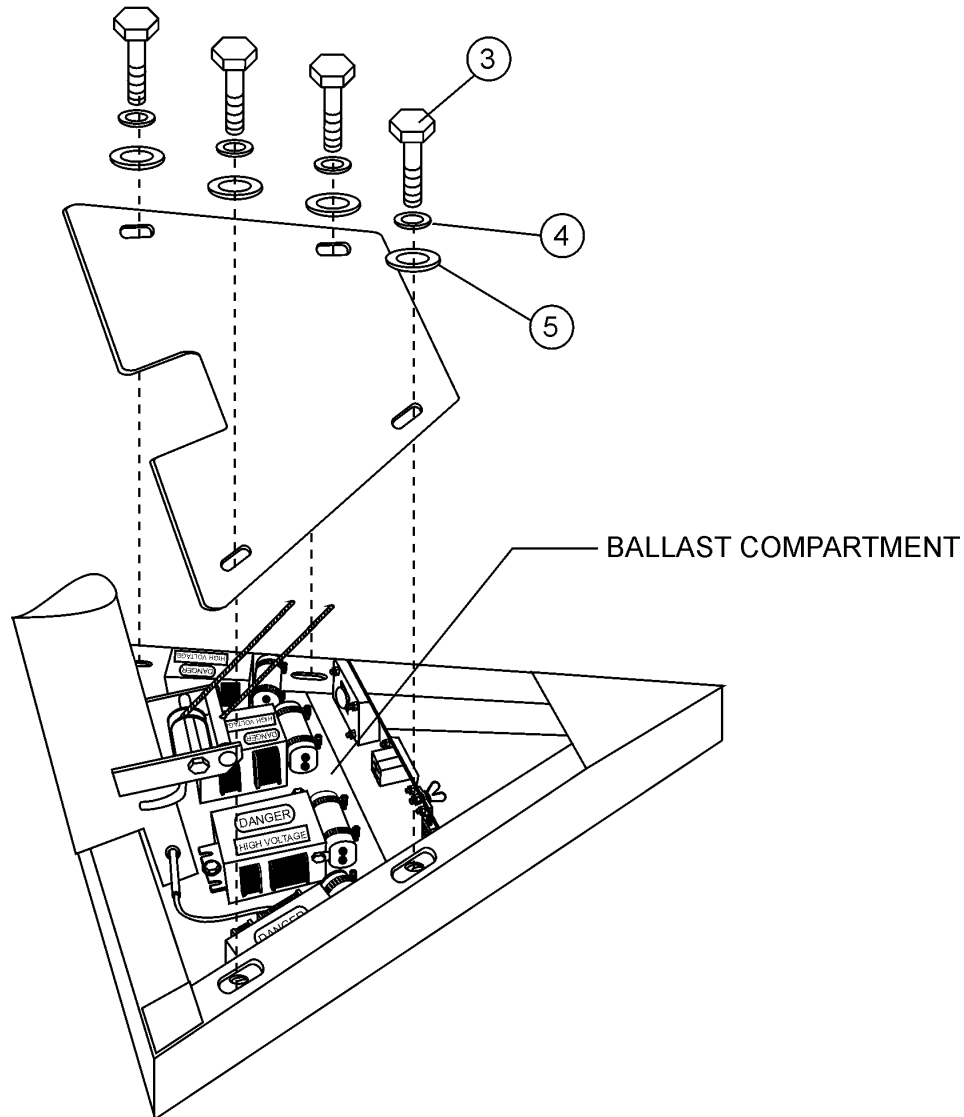
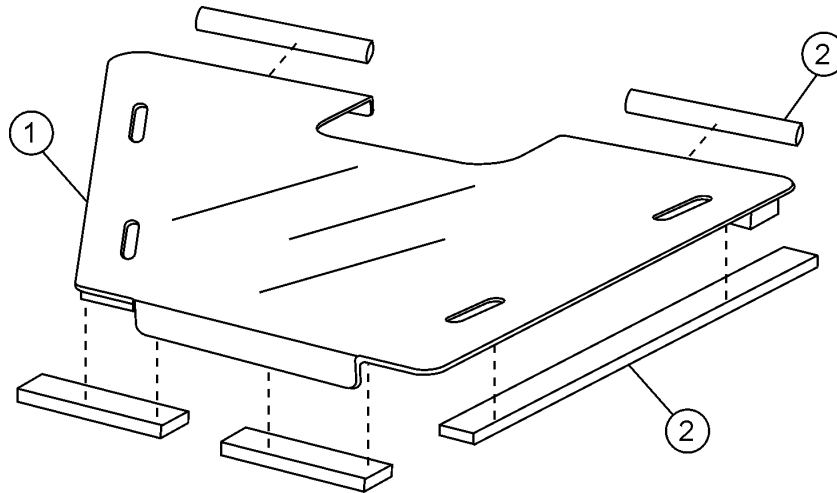

MODULAR LIGHT TOWER — BALLAST COMPARTMENT COVER ASSY.

BALLAST COMPARTMENT COVER ASSY.

GENERATOR/WELDER TRAILER MOUNTING ASSY.

<u>NO</u>	<u>PART NO</u>	<u>PART NAME</u>	<u>QTY.</u>	<u>REMARKS</u>
1	29000	PLATE, COVER	1	
2	29093	GASKET	6	QTY 6= 72 INCHES
3	0202	SCREW, HHC 5/16-18 X 1	4	
4	0161C	WASHER, LOCK 5/16	4	
5	0300B	WASHER, FLAT 5/16	4	

MODULAR LIGHT TOWER — BALLAST COMPARTMENT ASSY.

BALLAST COMPARTMENT ASSY.

<u>NO</u>	<u>PART NO</u>	<u>PART NAME</u>	<u>QTY.</u>	<u>REMARKS</u>
1	29156	BALLAST 1000W, MH CWA 120 VAC	4	BALLAST 1, 2, 3, AND 4
2	10434	CLAMP, 2-INCH HOSE	4	
3	11152	NUT, NYLOC 6-32	4	
4	1450	WASHER, FLAT #6 SAE	12	
5	29098	FAN ASSY.	1	
6	29097	SCREW, PHM 6-32 X 1-3/4	4	
7	8133	SCREW, RHM 10-32 X 3/4	4	
8	29000	PLATE, COVER	1	
9	8133	SCREW, RHM 10-32 X 3/4	8	
10	10136	WASHER, FLAT 3/8 SAE	2	
11	1JP104S	NUT, WING 3/8-16	1	REPLACES 29109
12	0166A	WASHER, HS 3/8 MED	2	
13	29001	JUNCTION BLOCK-GROUND	1	
14	19968	TERMINAL BLOCK	1	TB1
15	10019	NUT, NYLOC 10-32	2	
17	10133	NUT, NYLOC 3/8-16	1	
18	19999	CIRCUIT BREAKER	2	
19	19858	BRACKET CAPACITOR	4	
20	13252	SCREW, 1/4-20 X 4	4	
21	29093	GASKET	1	QTY 1= 12 INCHES
22	19598	CAPACITOR, 480 VAC μ F	4	C1, C2, C3 AND C4
23	10024	NUT, NYLOC 1/4-20	12	
24	0131A	SCREW, HH 1/4-20 X 3/4	8	
25	0948	WASHER, FLAT 1/4 SAE	8	

PAYMENT TERMS

Terms of payment for parts are net 30 days.

FREIGHT POLICY

All parts orders will be shipped collect or prepaid with the charges added to the invoice. All shipments are F.O.B. point of origin. Multiquip's responsibility ceases when a signed manifest has been obtained from the carrier, and any claim for shortage or damage must be settled between the consignee and the carrier.

MINIMUM ORDER

The minimum charge for orders from Multiquip is \$15.00 net. Customers will be asked for instructions regarding handling of orders not meeting this requirement.

RETURNED GOODS POLICY

Return shipments will be accepted and credit will be allowed, subject to the following provisions:

1. A Returned Material Authorization must be approved by Multiquip prior to shipment.
2. To obtain a Return Material Authorization, a list must be provided to Multiquip Parts Sales that defines item numbers, quantities, and descriptions of the items to be returned.
 - a. The parts numbers and descriptions must match the current parts price list.
 - b. The list must be typed or computer generated.
 - c. The list must state the reason(s) for the return.
 - d. The list must reference the sales order(s) or invoice(s) under which the items were originally purchased.
 - e. The list must include the name and phone number of the person requesting the RMA.
3. A copy of the Return Material Authorization must accompany the return shipment.
4. Freight is at the sender's expense. All parts must be returned freight prepaid to Multiquip's designated receiving point.
5. Parts must be in new and resalable condition, in the original Multiquip package (if any), and with Multiquip part numbers clearly marked.
6. The following items are not returnable:
 - a. Obsolete parts. (If an item is in the price book and shows as being replaced by another item, it is obsolete.)
 - b. Any parts with a limited shelf life (such as gaskets, seals, "O" rings, and other rubber parts) that were purchased more than six months prior to the return date.
 - c. Any line item with an extended dealer net price of less than \$5.00.
 - d. Special order items.
 - e. Electrical components.
 - f. Paint, chemicals, and lubricants.
 - g. Decals and paper products.
 - h. Items purchased in kits.
7. The sender will be notified of any material received that is not acceptable.
8. Such material will be held for five working days from notification, pending instructions. If a reply is not received within five days, the material will be returned to the sender at his expense.
9. Credit on returned parts will be issued at dealer net price at time of the original purchase, less a 15% restocking charge.
10. In cases where an item is accepted, for which the original purchase document can not be determined, the price will be based on the list price that was effective twelve months prior to the RMA date.
11. Credit issued will be applied to future purchases only.

PRICING AND REBATES

Prices are subject to change without prior notice. Price changes are effective on a specific date and all orders received on or after that date will be billed at the revised price. Rebates for price declines and added charges for price increases will not be made for stock on hand at the time of any price change.

Multiquip reserves the right to quote and sell direct to Government agencies, and to Original Equipment Manufacturer accounts who use our products as integral parts of their own products.

SPECIAL EXPEDITING SERVICE

A \$35.00 surcharge will be added to the invoice for special handling including bus shipments, insured parcel post or in cases where Multiquip must personally deliver the parts to the carrier.

LIMITATIONS OF SELLER'S LIABILITY

Multiquip shall not be liable hereunder for damages in excess of the purchase price of the item with respect to which damages are claimed, and in no event shall Multiquip be liable for loss of profit or good will or for any other special, consequential or incidental damages.

LIMITATION OF WARRANTIES

No warranties, express or implied, are made in connection with the sale of parts or trade accessories nor as to any engine not manufactured by Multiquip. Such warranties made in connection with the sale of new, complete units are made exclusively by a statement of warranty packaged with such units, and Multiquip neither assumes nor authorizes any person to assume for it any other obligation or liability whatever in connection with the sale of its products. Apart from such written statement of warranty, there are no warranties, express, implied or statutory, which extend beyond the description of the products on the face hereof.

PARTS AND OPERATION MANUAL

HERE'S HOW TO GET HELP

*PLEASE HAVE THE MODEL AND SERIAL NUMBER
ON-HAND WHEN CALLING*

PARTS DEPARTMENT

800-427-1244 or 310-537-3700

FAX: 800-672-7877 or 310-637-3284

SERVICE DEPARTMENT/TECHNICAL ASSISTANCE

800-478-1244 or 310-537-3700

FAX: 310- 537-4259

WARRANTY DEPARTMENT

888-661-4279, or 310-661-4279

FAX: 310- 537-1173

MAIN

800-421-1244 or 310-537-3700

FAX: 310-537-3927



MULTIQUIP INC.
POST OFFICE BOX 6254
CARSON, CA 90749
310-537-3700 • 800-421-1244
FAX: 310-537-3927
E-MAIL: mq@multiquip.com
WWW: multiquip.com

Atlanta • Boise • Dallas • Houston • Newark
Quebec, Canada • Manchester, UK • Rio De Janeiro, BR • Guadalajara, MX