

# OPERATION AND PARTS MANUAL



## **MODEL MQ600TD80 TRASH PUMP (DIESEL ENGINE)**

Revision #7 (10/09/06)

**THIS MANUAL MUST ACCOMPANY  
THE EQUIPMENT AT ALL TIMES.**



# **WARNING**



## **CALIFORNIA — Proposition 65 Warning**

**Diesel engine exhaust and some of its constituents are known to the State of California to cause cancer, birth defects and other reproductive harm.**

## **HERE'S HOW TO GET HELP**

PLEASE HAVE THE MODEL AND SERIAL  
NUMBER *ON-HAND* WHEN CALLING

### **MULTIQUIP CORPORATE OFFICE**

18910 Wilmington Ave.

Carson, CA 90746

Email: [mq@multiquip.com](mailto:mq@multiquip.com)

Internet: [www.multiquip.com](http://www.multiquip.com)

800-421-1244

FAX: 310-537-3927

### **PARTS DEPARTMENT**

800-427-1244

310-537-3700

FAX: 800-672-7877

FAX: 310-637-3284

### **MAYCO PARTS**

800-306-2926

310-537-3700

FAX: 800-672-7877

FAX: 310-637-3284

### **SERVICE DEPARTMENT**

800-421-1244

310-537-3700

FAX: 310-537-4259

### **TECHNICAL ASSISTANCE**

800-478-1244

FAX: 310-631-5032

### **WARRANTY DEPARTMENT**

800-421-1244, EXT. 279

310-537-3700, EXT. 279

FAX: 310-537-1173

© COPYRIGHT 2006, Multiquip INC.

Multiquip Inc, the MQ logo are registered trademarks of Multiquip Inc. and may not be used, reproduced, or altered without written permission. All other trademarks are the property of thier respective owners and used with permission.

This manual MUST accompany the equipment at all times. This manual is considered a permanent part of the equipment and should remain with the unit if resold.

The information and specifications included in this publication were in effect at the time of approval for printing. Illustrations are based on the *MQ Model MQ600TD80 Diesel Powered Trash Pump*. Illustrations, descriptions, references and technical data contained in this manual are for guidance only and may not be considered as binding. Multiquip Inc. reserves the right to discontinue or change specifications, design or the information published in this publication at any time without notice and without incurring any obligations.

**To find the latest revision of this  
publication, visit our website at:  
[www.multiquip.com](http://www.multiquip.com)**



# TRAINING CHECKLIST

## TRAINING CHECKLIST

This checklist will lists some of the minimum requirements for machine maintenance and operation. Please feel free to detach it and make copies. Use this checklist whenever a new operator is to be trained or it can be used as a review for more experienced operator's.

TRAINING CHECKLIST			
NO.	DESCRIPTION	OK?	DATE
1	Read Operator's Manual completely.		
2	Machine layout, location of components, checking of engine and oil levels.		
3	Fuel system, refueling procedure.		
4	Pump priming procedure.		
5	Emergency stop procedures.		
6	Engine start-up procedure.		
7	Lifting of machine (lifting bail)		
8	Pump applications (lift, uses etc.)		
9	Suction strainer placement.		
10	Hose connections.		
11	Pump placement.		
12	Trailer safety guidelines.		
13	Protective clothing guidelines.		
14	Vacuum test procedure.		
15	Machine transport and storage.		
16	Clean out pump cavity procedure.		

Operator \_\_\_\_\_ Trainee \_\_\_\_\_

COMMENTS:

# DAILY PRE-OPERATION CHECKLIST

## DAILY PRE-OPERATION CHECKLIST

DAILY PRE-OPERATION CHECKLIST	
1	Check engine oil level.
2	Check fuel level (and for clean fuel).
3	Check cooling fins and cooling air flow.
4	Check engine air cleaner.
5	Check engine battery and cable connections.
6	Check pump interior (impeller and volute).
7	Check pump seal.
8	Check pump casing for cracks.
9	Check trailer wheel lug nuts for tightness.
10	Check trailer wheel bearings.
11	Check trailer hitch and ball.
12	Check trailer springs and hardware (jack stand).
13	Check trailer tire pressure.
14	Check trailer lights.

COMMENTS:

## Multiquip MQ600TD80 — Diesel Powered Trash Pump

Training Checklist .....	3
Daily Pre-Operation Checklist .....	4
Here's How To Get Help .....	5
Table Of Contents .....	6
Parts Ordering Procedures .....	7
Safety Message Alert Symbols .....	8-9
Rules For Safe Operation .....	10-11
Operation and Safety Decals .....	12-13
Specifications .....	14
Pump Dimensions .....	16
Trailer Dimensions .....	17
Components .....	18-19
General Information .....	20
Application .....	21
Pre-Setup (Pump) .....	22
Initial Start-Up (Engine) .....	23-25
Towing Guidelines .....	26
Trailer Safety Guidelines .....	27-30
Trailer Wiring Diagram .....	31
Maintenance .....	32-35
Preparation For Long Term Storage .....	36
Troubleshooting (Pump) .....	37
Troubleshooting (Engine) .....	38-39
Trailer Brakes (Hydraulic) .....	40
Explanation Of Codes In Remarks Column .....	42
Suggested Spare Parts .....	43
Name Plate And Decals .....	44-45

Pump Impeller, Cleanout Discharge Assy. ....	46-47
Pump Suction Side Assy. ....	48-49
Intermediate Plate Assy. ....	50-51
Trailer Assy. ....	52-53
Battery/Fuel Assy. ....	54-55
Hydraulic Brake Line Assy. ....	56-57
Control Box Assy. (Deutz F4L913) .....	58-59
Control Box Assy. (Deutz F4L914) .....	60-61
Documentation Box .....	62-63

Terms and Conditions Of Sale — Parts .....	64
--	----

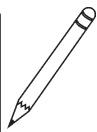
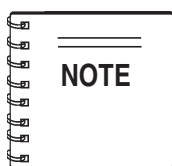

***Specification and part number are subject to change without notice.***

www.multiquip.com

**Ordering parts has never been easier!  
Choose from three easy options:**



**Order via Internet (Dealers Only):**

Order parts on-line using Multiquip's SmartEquip website!

- View Parts Diagrams
- Order Parts
- Print Specification Information



If you have an MQ Account, to obtain a Username and Password, E-mail us at: [parts@multiquip.com](mailto:parts@multiquip.com).

To obtain an MQ Account, contact your District Sales Manager for more information.

Goto [www.multiquip.com](http://www.multiquip.com) and click on **Order Parts** to log in and save!

Use the **internet** and qualify for a **5% Discount** on *Standard orders* for all orders which include complete part numbers.\*

Note: Discounts Are Subject To Change



**Order via Fax (Dealers Only):**

All customers are welcome to order parts via Fax.

**Domestic (US) Customers dial:**  
1-800-6-PARTS-7 (800-672-7877)

**Fax** your order in and qualify for a **3% Discount** on *Standard orders* for all orders which include complete part numbers.\*

Note: Discounts Are Subject To Change



**Order via Phone: Domestic (US) Dealers Call:**  
1-800-427-1244

**Non-Dealer Customers:**

Contact your local Multiquip Dealer for parts or call 800-427-1244 for help in locating a dealer near you.



**International Customers** should contact their local Multiquip Representatives for Parts Ordering information.

**When ordering parts, please supply:**

- |  |   |  |   |                                       |   |                                 |  |                                   |  |   |  |
|--|---|--|---|---------------------------------------|---|---------------------------------|--|-----------------------------------|--|---|--|
| <ul style="list-style-type: none"> <li><input type="checkbox"/> Dealer Account Number</li> <li><input type="checkbox"/> Dealer Name and Address</li> <li><input type="checkbox"/> Shipping Address (if different than billing address)</li> <li><input type="checkbox"/> Return Fax Number</li> <li><input type="checkbox"/> Applicable Model Number</li> <li><input type="checkbox"/> Quantity, Part Number and Description of Each Part</li> </ul> | <ul style="list-style-type: none"> <li><input type="checkbox"/> Specify Preferred Method of Shipment:           <table border="0" style="margin-left: 20px;"> <tr> <td><input checked="" type="checkbox"/> Fed Ex/UPS</td> <td><input checked="" type="checkbox"/> DHL</td> </tr> <tr> <td><input type="checkbox"/> Priority One</td> <td><input checked="" type="checkbox"/> Truck</td> </tr> <tr> <td><input type="checkbox"/> Ground</td> <td></td> </tr> <tr> <td><input type="checkbox"/> Next Day</td> <td></td> </tr> <tr> <td><input type="checkbox"/> Second/Third Day</td> <td></td> </tr> </table> </li> </ul> | <input checked="" type="checkbox"/> Fed Ex/UPS | <input checked="" type="checkbox"/> DHL | <input type="checkbox"/> Priority One | <input checked="" type="checkbox"/> Truck | <input type="checkbox"/> Ground |  | <input type="checkbox"/> Next Day |  | <input type="checkbox"/> Second/Third Day |  |
| <input checked="" type="checkbox"/> Fed Ex/UPS   | <input checked="" type="checkbox"/> DHL   |  |   |                                       |   |                                 |  |                                   |  |   |  |
| <input type="checkbox"/> Priority One  | <input checked="" type="checkbox"/> Truck   |  |   |                                       |   |                                 |  |                                   |  |   |  |
| <input type="checkbox"/> Ground  |   |  |   |                                       |   |                                 |  |                                   |  |   |  |
| <input type="checkbox"/> Next Day  |   |  |   |                                       |   |                                 |  |                                   |  |   |  |
| <input type="checkbox"/> Second/Third Day  |   |  |   |                                       |   |                                 |  |                                   |  |   |  |

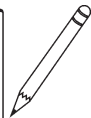
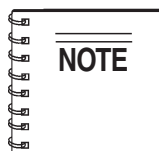

Unless otherwise indicated by customer, all orders are treated as *Standard Orders* and will ship within 24 hours. We will make every effort to ship *Air Shipments* the same day the order is received, if received prior to 2PM PST. *Stock Orders* must be noted on fax or web order form.

**WE ACCEPT ALL MAJOR CREDIT CARDS!**



# MQ600TD80 — SAFETY MESSAGE ALERT SYMBOLS

## FOR YOUR SAFETY AND THE SAFETY OF OTHERS!

Safety precautions should be followed at all times when operating this equipment. Failure to read and understand the Safety Messages and Operating Instructions could result in injury to yourself and others.

### NOTE

This Owner's Manual has been developed to provide complete instructions for the safe and efficient operation of the Multiquip Model **MQ600TD80 Trash Pump**. Refer to the engine manufacturers instructions for data relative to its safe operations.

**Before using this centrifugal trash pump, ensure that the operating individual has read and understands all instructions in this manual.**

## SAFETY MESSAGE ALERT SYMBOLS

The three (3) Safety Messages shown below will inform you about potential hazards that could injure you or others. The Safety Messages specifically address the level of exposure to the operator, and are preceded by one of three words: **DANGER**, **WARNING**, or **CAUTION**.

### **DANGER**

You **WILL** be **KILLED** or **SERIOUSLY** injured if you **DO NOT** follow directions.

### **WARNING**

You **CAN** be **KILLED** or **SERIOUSLY** injured if you **DO NOT** follow directions.

### **CAUTION**

You **CAN** be **INJURED** if you **DO NOT** follow directions.

Potential hazards associated with **MQ600TD80 Trash Pump** operation will be referenced with Hazard Symbols which appear throughout this manual, and will be referenced in conjunction with Safety Message Alert Symbols.

## HAZARD SYMBOLS

### **Lethal Exhaust Gases**



Engine exhaust gases contain poisonous carbon monoxide. This gas is colorless and odorless, and can cause death if inhaled. **NEVER** operate this equipment in a confined area or enclosed structure that does not provide ample free flow air.

### **Explosive Fuel**



**DIESEL** fuel is extremely flammable, and its vapors can cause an explosion if ignited. **DO NOT** start the engine near spilled fuel or combustible fluids. **DO NOT** fill the fuel tank while the engine is running or hot. **DO NOT** overfill tank, since spilled fuel could ignite if it comes into contact with hot engine parts or sparks from the ignition system. Store fuel in approved containers, in well-ventilated areas and away from sparks and flames. **NEVER** use fuel as a cleaning agent.

### **Burn Hazards**



Engine components can generate extreme heat. To prevent burns, **DO NOT** touch these areas while the engine is running or immediately after operations. Never operate the engine with heat shields or heat guards removed.

### **Rotating Parts**



**NEVER** operate equipment with covers, or guards removed. Keep fingers, hands, hair and clothing away from all moving parts to prevent injury.

# MQ600TD80 — SAFETY MESSAGE ALERT SYMBOLS



## Accidental Starting



OFF

**ALWAYS** place the engine ON/OFF switch in the **OFF** position, and remove the ignition key when the machine is not in use.



## Respiratory Hazard



**ALWAYS** wear approved respiratory protection.



## Sight and Hearing hazard

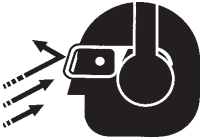

**ALWAYS** wear approved eye and hearing protection.



## Equipment Damage Messages

Other important messages are provided throughout this manual to help prevent damage to your trash pump, other property, or the surrounding environment.

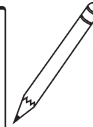
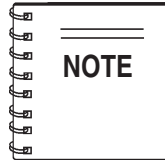

This trash pump, other property, or the surrounding environment could be damaged if you do not follow instructions.

# RULES FOR SAFE OPERATION

## DANGER

### Read this manual!

Failure to follow instructions in this manual may lead to serious injury or even death! This equipment is to be operated by trained and qualified personnel only! This equipment is for industrial use only.

The following safety guidelines should always be used when operating the **MQ600TD80 Trash Pump**:

### GENERAL SAFETY

■ **DO NOT** operate or service this equipment before reading this entire manual.



■ This equipment should not be operated by persons under 18 years of age.

■ **NEVER** operate this equipment without proper protective clothing, shatterproof glasses, steel-toed boots and other protective devices required by the job.



■ **NEVER** operate this equipment when not feeling well due to fatigue, illness or taking medicine.



■ **NEVER** operate this equipment under the influence of **drugs** or **alcohol**.



■ **ALWAYS** wear proper respiratory (mask), hearing and eye protection equipment when operating the mixer.



■ **NEVER** place hands inside the drum while the blades are rotating.

■ Whenever necessary, replace nameplate, operation and safety decals when they become difficult read.

■ Manufacture does not assume responsibility for any accident due to equipment modifications.

■ **NEVER** use accessories or attachments, which are not recommended by Multiquip for this equipment. Damage to the equipment and/or injury to user may result.

■ **NEVER** touch the hot exhaust manifold, muffler or cylinder. Allow these parts to cool before servicing engine or mixer.



■ **High Temperatures** – Allow the engine to cool before adding fuel or performing service and maintenance functions. Contact with **hot!** components can cause serious burns.

■ The air-cooled diesel engine of this pump requires an adequate free flow of cooling air. **NEVER** operate the pump in any enclosed or narrow area where free flow of the air is restricted. If the air flow is restricted it will cause serious damage to the pump or engine and may cause injury to people. Remember the mixer's engine gives off **DEADLY** carbon monoxide gas.

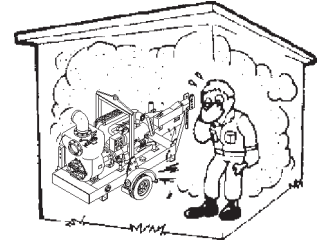

■ **ALWAYS** refuel in a well-ventilated area, away from sparks and open flames.

■ **ALWAYS** use extreme caution when working with **flammable** liquids. When refueling, **stop the engine** and allow it to cool. **DO NOT smoke** around or near the machine. Fire or explosion could result from fuel vapors, or if fuel is spilled on a hot engine.



■ **NEVER** operate the pump in an explosive atmosphere or near combustible materials. An explosion or fire could result causing severe **bodily harm or even death**.

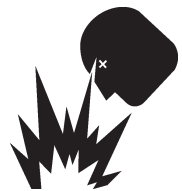

■ Topping-off to filler port is dangerous, as it tends to spill fuel.

■ Stop the engine when leaving the pump unattended.

■ Block the unit when leaving or when using on a slope.

■ Maintain this equipment in a safe operating condition at

■ **NEVER** use accessories or attachments, which are not recommended by Multiquip for this equipment. Damage to the equipment and/or injury to user may result. all times.

# RULES FOR SAFE OPERATION

- **NEVER** pump volatile, flammable or low flash point fluids. These fluids could ignite or explode.
- **NEVER** pump corrosive chemicals or water containing toxic substances. These fluids could create serious health and environmental hazards. Contact local authorities for assistance.
- **NEVER** open the priming plug when pump is hot. Hot water inside could be pressurized much like the radiator of an automobile. Allow pump to cool to the touch before loosening plug.
- **NEVER** open the pump housing during operation or start the pump with the cover off. The rotating impeller inside the pump can cut or sever objects caught in it.
- **NEVER** block or restrict flow from discharge hose. Remove kinks from discharge line before starting pump. Operation with a blocked discharge line can cause water inside pump to overheat.
- **NEVER** Run engine without air cleaner. Severe engine damage may occur.
- **ALWAYS** read, understand, and follow procedures in Operator's Manual before attempting to operate equipment.
- **ALWAYS** be sure the operator is familiar with proper safety precautions and operations techniques before using pump.
- **ALWAYS** store equipment properly when it is not being used. Equipment should be stored in a clean, dry location out of the reach of children.
- Refer to the *Engine Owner's Manual* for engine technical questions or information.
- **ALWAYS** fill the pump casing with water before starting the engine. Failure to maintain water inside the pump housing will cause severe damage to the pump.
- In winter drain water from pump housing to prevent freezing.
- **ALWAYS** make sure pump is correctly secured to the trailer. Check all supports attaching the pump to the trailer and make sure they are tight.
- **ALWAYS** make sure that the pump's trailer is placed on solid level ground so that it cannot slide or shift around, endangering workers. Place blocks under the trailer's bumper to make it level (prevents tipping), and use a chocked block underneath the wheels to prevent rolling. Also keep the immediate area free of bystanders.
- **High Temperatures** – Allow the engine to cool before adding fuel or performing service and maintenance functions. Contact with *hot* components can cause serious burns.

## Maintenance Safety

- **NEVER** lubricate components or attempt service on a running machine.
- **ALWAYS** allow the machine a proper amount of time to cool before servicing.
- Keep the machinery in proper running condition.
- Fix damage to the machine immediately and always replace broken parts.
- Dispose of hazardous waste properly. Examples of potentially hazardous waste are used motor oil, fuel and fuel filters.
- **DO NOT** use food or plastic containers to dispose of hazardous waste.
- **DO NOT** pour waste, oil or fuel directly onto the ground, down a drain or into any water source.

## Lifting

- The Pump has an operating weight of 2,800 lbs. (1,270 KG). Use lifting equipment with a rated capacity of at least 14,000 lbs (6,350 KG). Remove suction & discharge hoses/pipes before lifting.

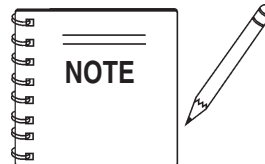

**Weight does not include trailer or other accessories.**

## EMERGENCIES

- **ALWAYS** know the location of the nearest **fire extinguisher** and **first aid kit**.



- In emergencies **always** know the location of the nearest phone or **keep a phone on the job site**. Also know the phone numbers of the nearest **ambulance**, **doctor** and **fire department**. This information will be invaluable in the case of an emergency.



# OPERATION AND SAFETY DECALS

## Machine Safety Decals

The MQ600TD80 Centrifugal Trash pump is equipped with a number of safety decals. These decals are provided for operator safety and maintenance information. The illustration below and on the next page shows these decals as they appear on the machine. Should any of these decals become unreadable, replacements can be obtained from your dealer.

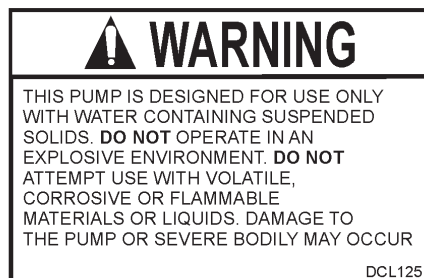
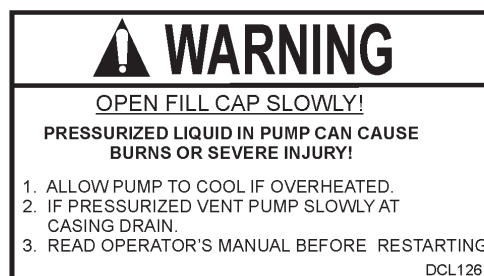
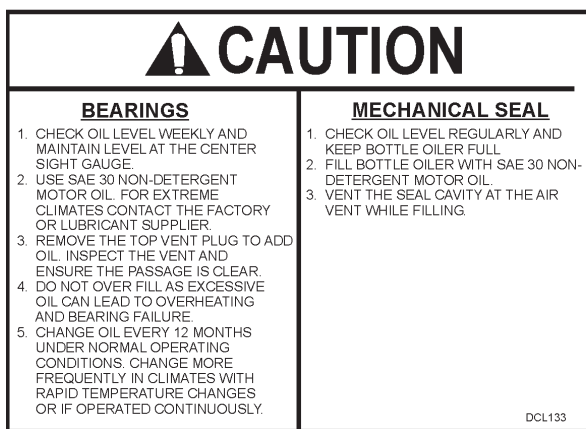
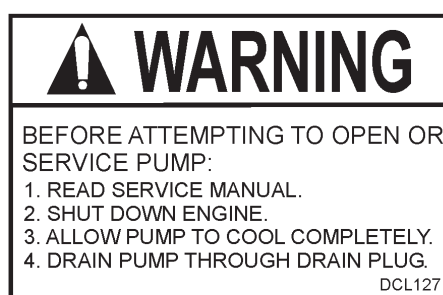
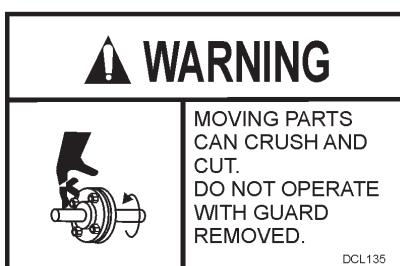
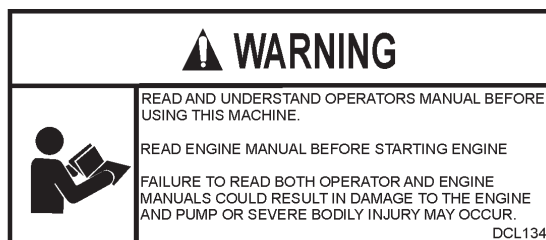
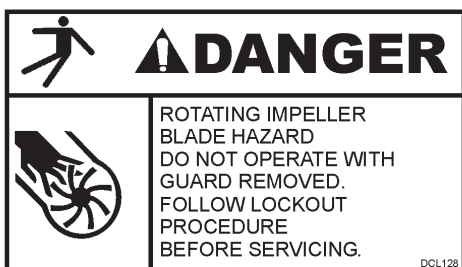



P/N 511783



P/N 511782

DIESEL FUEL

P/N EM995

**INSPECT BEFORE TOWING**

- TIGHTNESS OF WHEEL NUTS.
- TIRE PRESSURE.
- 1. USE MANUFACTURES RECOMMENDED TORQUE VALUES WHEN TIGHTENING WHEEL LUG NUTS.
- 2. USE MANUFACTURES RECOMMENDED TIRE PRESSURE VALUES WHEN INFLATING TIRES. **DO NOT** EXCEED RECOMMENDED TIRE PRESSURE.

DCL 151

**TABLE 1. ENGINE SPECIFICATIONS**

Engine Make	Deutz
Engine Model	F4L913/F4I913
Engine Type	Air Cooled 4-Stroke Diesel
Number Of Cylinders	4
Bore/Stroke (F4L913)	102/125 mm
Bore/Stroke (F4L914)	102/132 mm
Continuous Engine HP (F4L913)	60.0 HP @ 1,900 RPM*
Continuous Engine HP (F4L914)	68.3 HP @ 1,900 RPM*
Combustion Method	Direct Fuel Injection
Oil Grade	See Table 2, page 20
Oil Capacity	9.5 gal/2.5 liters
Fuel Type	Diesel
Fuel Tank Capacity	40 gal/51.0 liters
Starting Method	Electric Start
*Maximum Engine HP (intermittent) @ 2,500 RPM = 80 HP	

**TABLE 2. PUMP SPECIFICATIONS**

Maximum Pumping Capacity	1600 gpm (6,055 lpm)
Maximum Suction Lift*	25 FT. (7.6 meters)
Maximum Total Head	150 FT. (45.7 meters)
Maximum Pressure	64.9 psi
Maximum Solids	3 in. (76 mm)
Suction and Discharge Diameter	6 in. (152 mm)
Dimensions (LxWxH) Trailer Mounted	80 x 39 x 49 in. (203 x 99 x 124 cm.)
Weight (No Fuel)	3,060 lbs. (1,388 kg.)
* Based on pump operating at sea level. Maximum suction lift will be less at higher altitudes.	

### SOUND MEASUREMENTS

The required sound specifications, per Appendix 1, paragraph 1.7.4.f of the EC-Machine Regulations, are defined as follows:

The sound pressure level at the operator's location (L) = 87 dB (A)

The sound power level (L) = 97 dB (A)

These sound values are determined according to ISO 3744 for the sound power level (L) and ISO 6081 for the sound pressure level (L) at the operator's location.

The sound measurements were obtained with the unit operation on pavement at nominal speed.



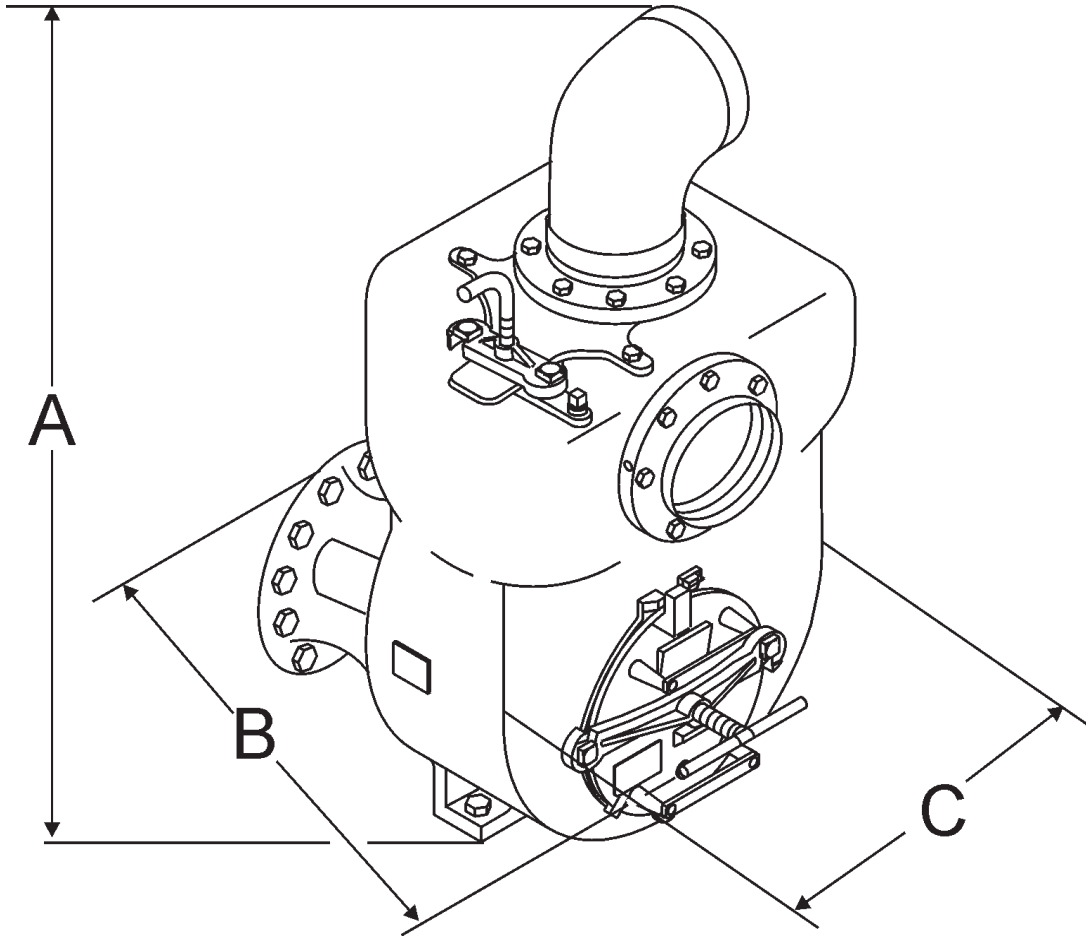

**Figure 1. Pump Dimensions**

TABLE 3. PUMP DIMENSIONS		
REFERENCE LETTER	DESCRIPTION	DIMENSIONS INCHES (MM)
A	MEASURED FROM TOP OF 90 DEGREE ELBOW TO MOUNTING FEET (HEIGHT).	45.5 INCHES (1,156 MM)
B	MEASURED FROM TIP OF INTERMEDIATE HOUSING TO TIP OF LOCKING HANDLE (DEPTH).	32 INCHES (813 MM)
C	MEASURED FROM PUMP SIDE-WALL TO SIDE-WALL (WIDTH).	24.5 INCHES (622 MM)

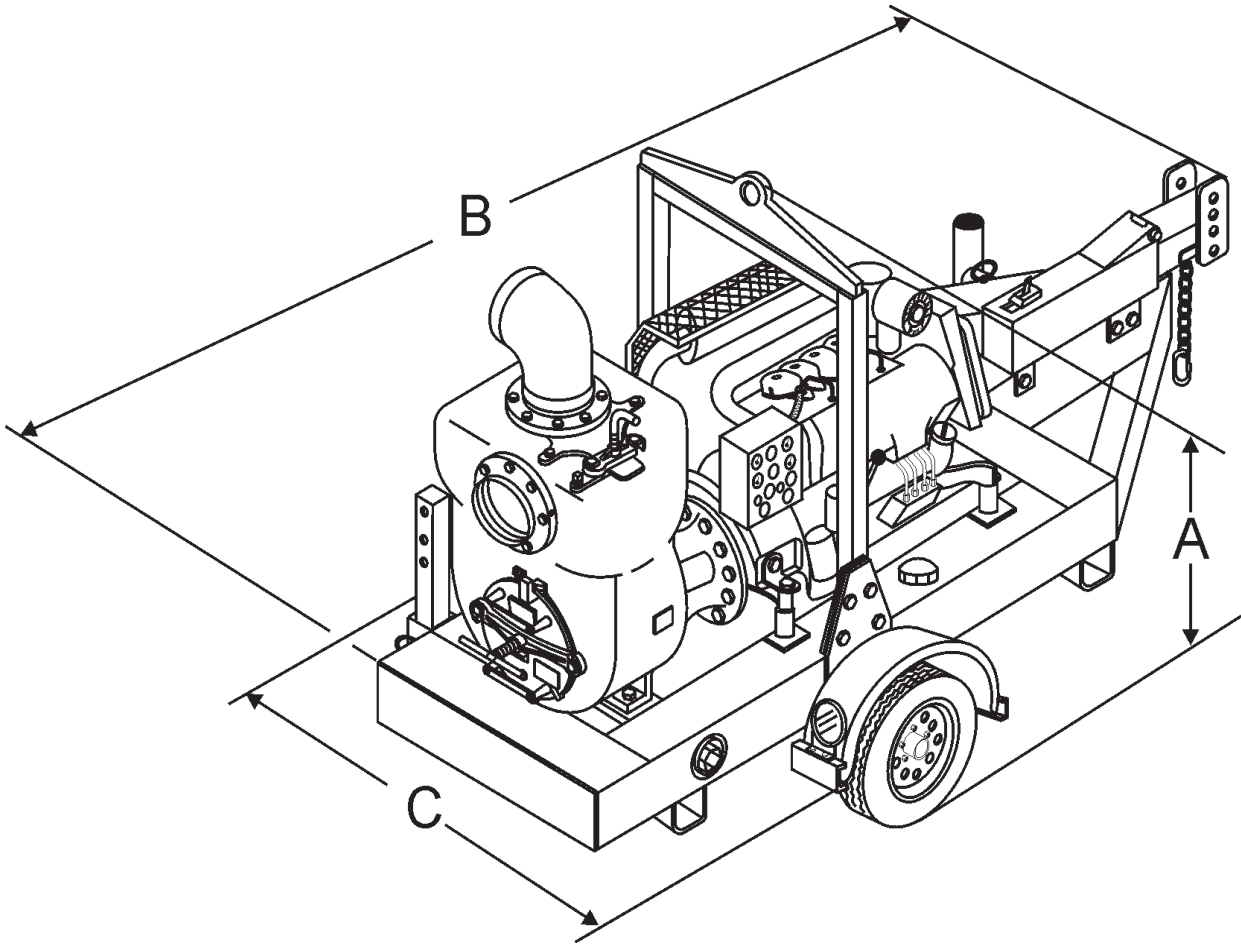

**Figure 2. Trailer Dimensions**

TABLE 4. TRAILER DIMENSIONS		
REFERENCE LETTER	DESCRIPTION	DIMENSIONS INCHES (MM)
A	MEASURED FROM TOP OF LIFTING BALE TO BOTTOM OF TIRE (HEIGHT).	65.5 INCHES (1,664 MM)
B	MEASURED FROM TIP OF TRAILER COUPLER TO REAR OF TRAILER FRAME (LENGTH).	115 INCHES (2,921 MM)
C	MEASURED FROM FENDER TO FENDER (WIDTH).	64 INCHES (1,626 MM)

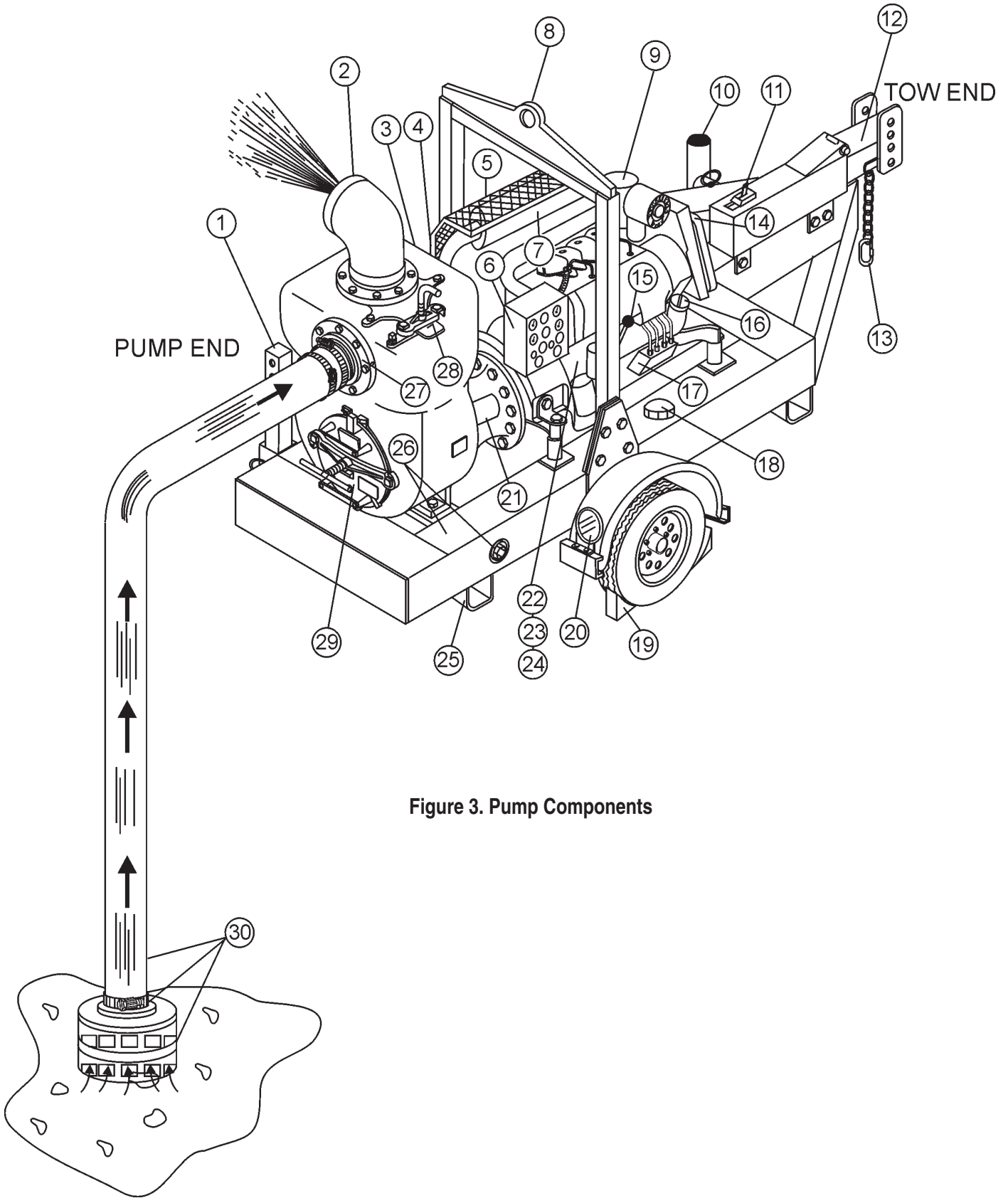

Figure 3. Pump Components

Figure 3 shows the location of the components and basic components for the MQ600TD80 trash pump. The function of each component or control is described below:

1. **Pump End Jack Stand** – Use this jack stand to level and support the trash pump.
2. **Pump Discharge Port** – Discharges water and debris from the pump.
3. **Bearing Sight Glass** – Use this sight glass to determine if oil is present. Oil must be **visible** within the sight glass at all times.
4. **Mechanical Seal Sight Glass** – Use this sight glass to determine if oil is present. Oil must be **visible** within the sight glass at all times.
5. **Battery** – +12 VDC battery compartment.
6. **Control Box Panel** – Monitors engine functions and will shut down the engine for low oil pressure, high coolant temperature, alternator charge and V-belt failure.
7. **Muffler/Guard** – **DO NOT** touch the muffler when engine is running. The muffler can become extremely hot, causing severe burns. **NEVER** run the pump with the muffler guard removed.
8. **Lifting Bail** – When lifting of the trash pump by crane is required, use this lifting bail. Note: this lifting bail is balanced for a fully configured trash pump; removal of any trash pump components will un-balance the lifting bail.
9. **Oil Bath Cleaner** – Prevents dirt and any foreign debris from entering the engine. Service this unit as recommended in the maintenance section of this manual.
10. **Tow End Jack Stand** – Use this jack stand to level and support the trash pump.
11. **Brake Coupler** – This device will activate the hydraulic braking system of the pump's trailer in the event the pump's trailer becomes detached from the towing vehicle.
12. **Tow Hitch Coupler** – Requires a 2-5/16 ball hitch or a 3-inch pintle.
13. **Safety Chain** – Always attach safety chain to the towing vehicle. **NEVER!** tow the trash pump with the safety chain unattached.
14. **Documentation Box** – Contains documentation for the pump and engine.
15. **Engine Throttle Lever** – Controls the speed of the engine. For load conditions (pumping water) **ALWAYS** run the engine at **full speed**.
16. **Oil Filler** – Fill as recommended in the maintenance section of this manual.
17. **Engine (Diesel)** – This pump uses a Deutz FL913 air-cooled, 4-stroke diesel engine. See the Deutz Operation manual supplied with the trash pump for additional engine information.
18. **Fuel Gauge/Filler Port** – Read top of gauge to determine fuel level. Re-fuel using only recommended types of diesel fuels (see Deutz Operation Manual). **DO NOT** top off fuel, wipe up any spilled fuel immediately.
19. **Chock Blocks** – Place these blocks (not included as part of the trash pump package) under each trailer wheel to prevent rolling.
20. **Trailer Lights** – Before towing trash pump, make sure that both trailer lights are functioning correctly. **NEVER** tow the trash pump if these lights are not working.
21. **Pump Shaft Guards** – To prevent injury to hands and fingers these two guard covers (one each side of pump housing) are to remain in place at all times when the pump is in use.
22. **Dipstick** – Read this gauge to determine the level oil in the engine crankcase. Fill with only recommended type oil as referenced in the maintenance section of this manual.
23. **Fuel Filters** – This pump design incorporates the use of four fuel filters, maintain these filters as recommended in the maintenance section of this manual.
24. **Fuel Water Separator** – Removes water from the fuel system. Inspect and clean as recommended in the maintenance section of this manual.
25. **Support Tubes** – These tubes protect the fuel tank from being damaged when the pump frame is lying on a flat surface.
26. **Fuel Tank/Drain Plug** – The fuel tank is part of the frame (sides). It holds 40 gallons (51 liters) of diesel fuel. Remove this drain plug to drain the fuel tank.
27. **Pump Intake Port** – Intakes water and debris from the source.
28. **Fill Cap** – Remove this cap to prime the pump with water.
29. **Clean-Out Cover** – Remove this cover to clean and remove foreign debris from the trash pump.
30. **Accessories** – Hoses, strainers and clamps are the required accessory components for normal operation of this trash pump. **Contact** your nearest Multiquip dealer for information on the components.

The MQ600TD80 Trash Pump is a self-priming centrifugal trash pump powered by a 80 horsepower air-cooled four stroke Deutz diesel engine. Both the intake (suction) and discharge ports on the MQ600TD80 incorporate a 6-inch diameter opening, which allows the pump to charge as needed at a rate of approximately 1,600 gpm or 6,055 lpm.

This is a self-priming pump design and the pump casing must be filled with water before starting operation. The engine drives a rotating disc with two ( or more vanes) called an impeller that creates an area of low pressure inside the pump. Priming is accomplished when all air is purged from the pump and suction line allowing water to flow continuously into the pump.

## Trash Pump

Trash pumps derive their name from their ability to handle a greater amount of debris and solids than standard centrifugal pumps. These pumps generally handle solids up to 1/2 the size of the discharge opening making them less likely to clog. Also trash pumps are capable of handling water with 25% solids by weight.

The advantage of using a trash pump is that it can be quickly and easily disassembled in the field to remove debris in the event the pump becomes clogged.

## Suction Lift

This pump has a maximum suction lifts up to 25 feet at sea level. ***At elevations above sea level suction lift decreases at a rate of 1 foot of suction lift per 1,000 feet of elevation.*** Therefore, when this pump is being used at an elevation of 5,000 feet the maximum suction lift is reduced to 20 feet. It is recommended that the pump be located as close to the source as possible to minimize suction lift.

## Pump Support

The pump should always be placed on solid stationary ground in a level position. To prevent the trailer from tipping, place blocks under the trailer's bumper. In addition, place chock blocks behind each wheel to prevent the trailer from rolling.

**NEVER** place the pump on ***soft soil***. The suction hose or pipe connection should always be checked for tightness and leaks. A small suction leak in the hose or fittings could prevent the pump from priming.

## Elevation

Elevations over 3,000 feet will effect the performance of the pump. Due to less atmospheric pressure at higher altitudes, pumps **DO NOT** have the priming ability that they have at sea level.

A general rule of thumb is that for every 1,000 feet of elevation above sea level a pump will lose one foot of priming ability.

For example, in Flagstaff, Arizona where the elevation is approximately 7,000 feet, the pump would have a suction lift of only 18 feet rather than the 25 feet at sea level.

## Pump Clean-out

The clean-out cover on the MQ600TD80 has been design for easy removal that allows for easy access to the wear plate and impeller for cleaning and servicing.

In order to comply with local laws regarding spark arresters, consult the engine distributor or the local Health and Safety Administrator.

## Mechanical Seal Lubrication

The pump uses a oil lubricated mechanical seal to prevent water from seeping into the engine. The oil in the seal chamber lubricates the seal and prevents it from overheating. Never operate the pump without water in the casing as this may cause the seal to fail. ( **See section on seal maintenance**).

## Engine Safety

Internal combustion engines present special hazards during operation and fueling! Failure to follow the safety guidelines described in the Rules for Safe Operation section of this manual and the Deutz Engine Operator's Manual could result in severe injury or death.

## Accessories

Multiquip offers a complete line of fittings, hoses, and clamps to properly connect the pump to match various job conditions. Refer to the part list in section 2 of this manual for a complete list of accessories

Figure 4 below shows a typical application using the MQ600TD80 diesel powered trash pump. Please note that this pump is intended for the removal of clean water and water containing some debris and solids. Maximum size of solids should not exceed 3 inches (76 mm) in diameter. **DO NOT** set strainer on bottom of water bed. Placing the strainer above the water bed will prevent the pump from drawing in excessive amounts of sand and foreign debris.

The following terms are usually used when referring to *lift* or *head*:

1. **Static Suction Lift** – The vertical distance from the water line to the center of the impeller.
2. **Static Discharge Head** – The vertical distance from the discharge outlet to the point of discharge or liquid level when discharging into the bottom of a water tank.
3. **Dynamic Suction Head** – The static suction lift plus the friction in the suction line. Also referred to as **total suction head**.
4. **Dynamic Discharge Head** – The static discharge head plus the friction in the discharge line. Also referred to as **total discharge head**.
5. **Total Dynamic Head** – The Dynamic Head Suction Head plus the Dynamic Discharge Head. Also referred to as **total head**.

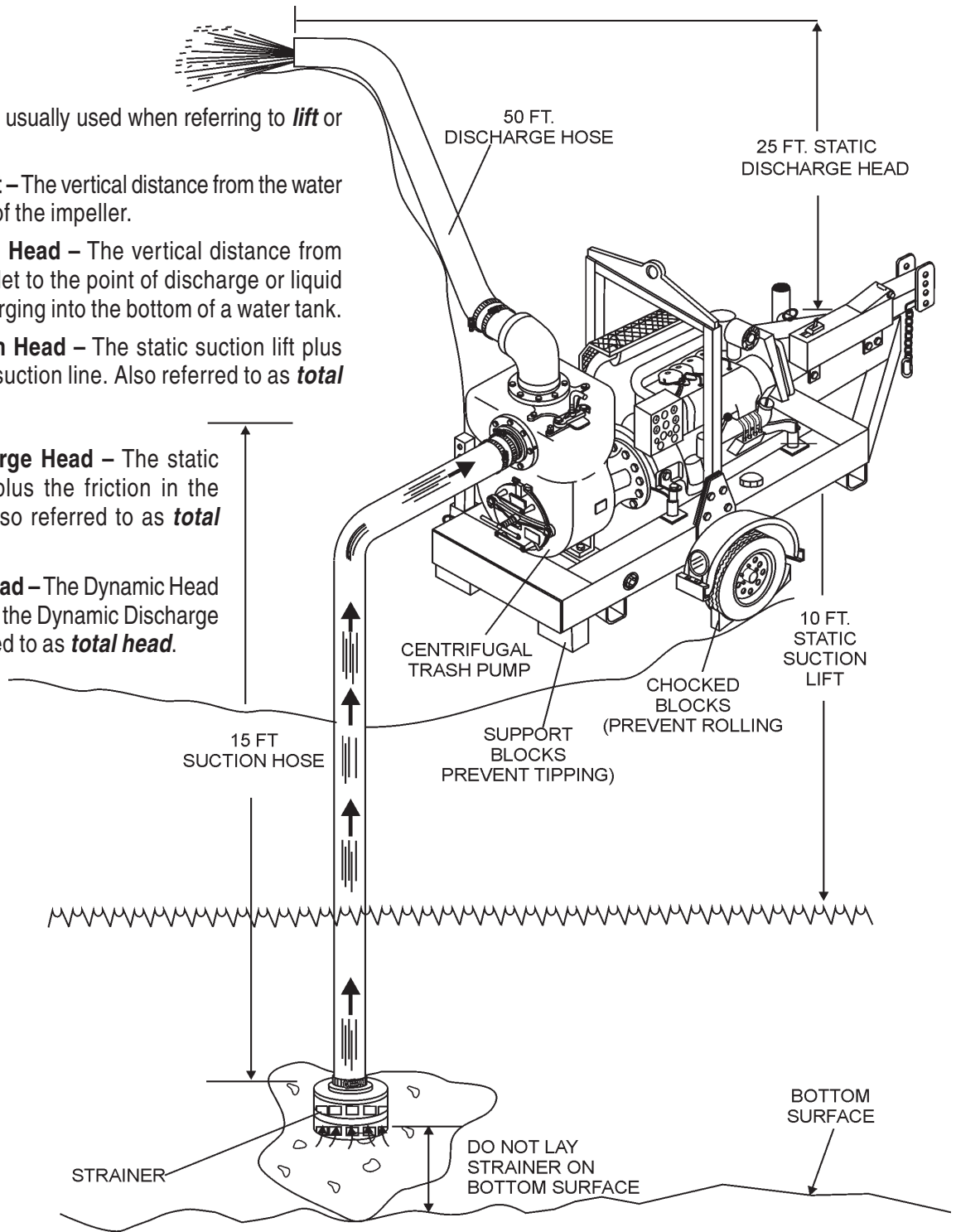
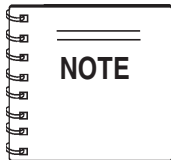

Figure 4. Pump Application

## Before Starting

1. Read safety instructions at the beginning of manual.
2. Place pump as near to water as possible, on a firm flat, level surface.
3. To prime pump, remove fill cap (Figure 3) and fill pump case with water. If the pump case is not filled with water before starting, it will not begin pumping.



Pump casing **must** be filled with water before using pump, otherwise pump will not be able to begin pumping.

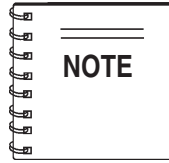

Suction and discharge hoses are available from Multiquip. Contact your nearest dealer for more information.

5. The discharge hose is usually a **collapsible** (thin-walled) hose, however if a thin-walled discharge hose is not available, a rigid suction hose can be substituted in its place.
6. Make sure the **suction strainer** (Figure 3) is clean and securely attached to the water end of the suction hose. The strainer is designed to protect the pump by preventing large objects from being pulled into the pump.

## WARNING

**DO NOT** open fill cap if pump is **hot!** Water inside may be under pressure.

## CAUTION

The strainer should be positioned so it will remain completely **under water**. Running the pump with the strainer above water for long periods can damage the pump.

4. Check for **leaks** between pump and engine. If water is leaking between the pump and engine housing, the seal inside the pump may be worn or damaged. Continued operation of the pump is not recommended. Further usage of the pump under these conditions may cause severe water damage to engine.

## Hoses and Clamps

1. Check that all hoses are **securely** attached to the pump. Make certain suction hose (Figure 3) does not have any air leakage. Tighten hose clamps and couplings as required.
2. It is recommended that 2 clamps be used when securing the suction hose to the inlet side of the pump.
3. Remember suction hoses must be **rigid** enough not to collapse when the pump is in operation.
4. Check that the **discharge** hose (Figure 3) is not restricted. Place hose so that it lays as straight as it is possible on the ground. Remove any twists or sharp bends from hose which may block the flow of water.

## CAUTION

**DO NOT** pump flammable fluids, corrosive chemicals or fluids containing toxic substances. These fluids can create potentially dangerous health and environmental hazards. Contact local authorities for assistance.

7. Pipes, hoses, fittings and elbows all produce friction that can significantly reduce the flow of water. Keep hose length to a minimum and minimize the use of elbows and other fittings to reduce friction.
8. Always use a suction hose or pipe that matches the size of the pump inlet to insure optimum performance and reduce the risk of damage to the pump.
9. It is recommended that the discharge hose or pipe match the size of the pump outlet to reduce friction as much as possible. Using a discharge line that is larger than the pump outlet will reduce friction and improve water flow. Similarly, a smaller line will reduce water flow by increasing friction.

# MQ600TD80 — INITIAL START-UP (ENGINE)

## CAUTION

**DO NOT** attempt to start the engine unless the pump has previously been **primed** with water. Severe damage to the pump's mechanical seal will occur if pump has not been primed.

### Engine Oil

1. Make sure pump/engine is on level ground.
2. Pull the engine oil dipstick from its holder.
3. Verify that oil level (Figure 5) is maintained between the two notches on the dipstick.

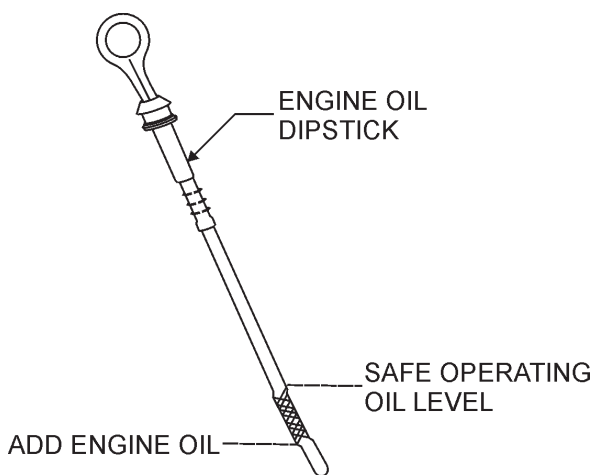

**Figure 5. Engine Oil Dipstick**

4. If engine oil is low, fill engine crankcase with lubricating oil through filler hole (Figure 6), but do not overfill.

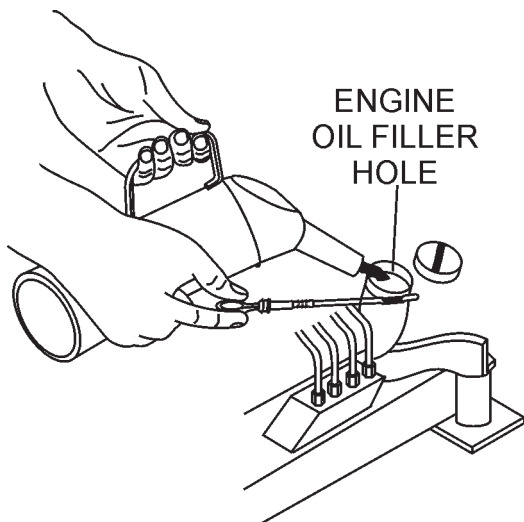

**Figure 6. Engine Oil Filler Hole**

5. The oil listed in Table 5 is recommended to ensure better engine performance. Use class CD or higher grade motor oil.

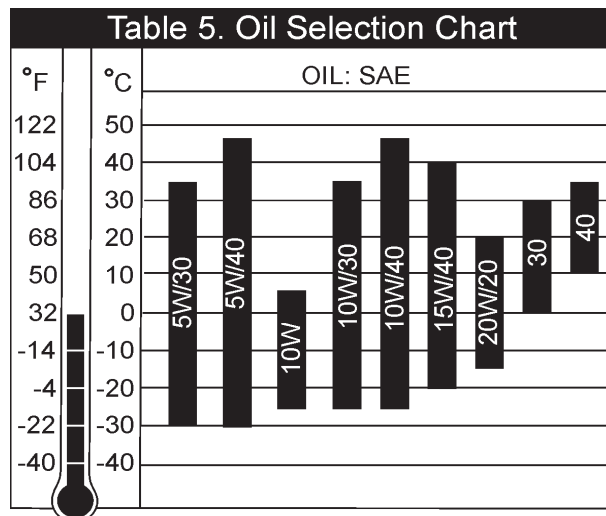

### Fuel

## DANGER

**NEVER** fill the fuel tank while the engine is running or in the dark. Fuel spillage on a hot engine can cause a fire or explosion. If fuel spillage occurs, wipe up the spilled fuel completely to prevent fire hazards.



1. Determine if engine fuel is low by reading fuel indicator gauge on top fuel cap. Fill with recommended type diesel fuel. **DO NOT** fill the tank beyond capacity.



## DANGER

**DO NOT** smoke while refueling, motor fuels are highly flammable and can be dangerous if mishandled.



2. Handle fuel in a safety container. If the container does not have a spout use a funnel.
3. Pay attention to the fuel tank capacity when replenishing fuel. Refer to the fuel tank capacity listed in Engine Specification Table 1.
4. Tighten fuel tank cap securely after filling.

# MQ600TD80 — INITIAL START-UP (ENGINE)

## Speed Control Lever

1. Set the **Speed Control Lever** (Figure 7) to a position half way between start and stop.

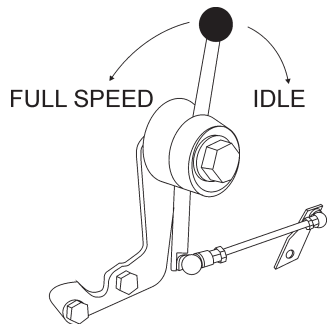

Figure 7. Speed Control Lever

## Control Box (F4L913 Old Style)

1. Insert ignition key into the ignition switch located on the control box (Figure 8)

### NOTE:

This version engine does not use the glow plug indicator lite.

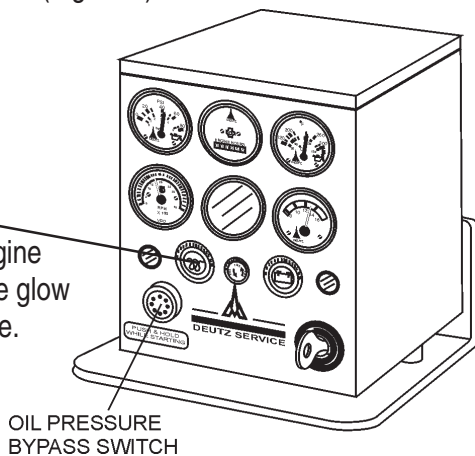

Figure 8. Control Box (Old Style)

2. Turn ignition key to position I, and verify that charge indicator light comes **ON**.
3. Press and hold the "oil pressure bypass switch".
4. Continue turning the ignition key through positions II and III.
5. Release ignition key as soon as engine starts, and verify that ignition key automatically returns back to position I.
6. Release the "oil pressure bypass switch".
7. Verify charge indicator light goes **OFF** immediately when engine is started.
8. If charge indicator remains lit, increase engine speed until light goes off. When the charge indicator light goes off, it can then be assumed that the charging system is working correctly.

9. If the charge light remains on while the engine is running, refer to Table 9 (Engine Troubleshooting) or the Deutz Engine Repair Manual.
10. Move **speed control lever** to full speed position for maximum engine speed. (See Fig. 7)

## Control Box (F4L914 New Style)

1. Insert ignition key into the ignition switch located on the control box (Figure 9)

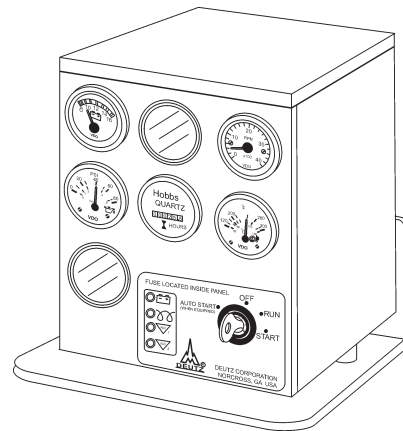

Figure 9. Control Box (New Style)

2. Turn ignition key to the **RUN** position, and verify that voltmeter gauge indicates 12 VDC.
3. Verify that the **battery** and **glow plug** status LED indicator lamps are **ON**.
4. Continue turning the ignition key from the **RUN** position to the **START** position.
5. Release ignition key as soon as engine starts, and verify that ignition key automatically returns back to the **RUN** position.
6. Verify that the **battery charge** and **glow plug** status LED indicator lamps are **OFF**.
7. If battery charge indicator lamp remains lit, increase engine speed until light goes off. When the charge indicator light goes off, it can then be assumed that the charging system is working correctly.
8. If the charge light remains on while the engine is running, refer to Table 9 (Engine Troubleshooting) or the Deutz Engine Repair Manual.
9. If the **AUX 1** status LED lamp is **ON**, stop engine and check for broken or defective V-belt.
10. Move **speed control lever** to full speed position for maximum engine speed. (See Fig. 7)

## MQ600TD80 — INITIAL START-UP (ENGINE)

### Operation

1. The MQ600TD80 trash pump should begin pumping water within a minute depending on the length of suction hose and height the pump is above water.

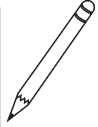
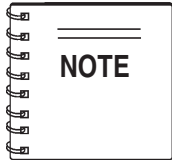

Longer suction hoses will require more time for the pump to begin pumping water.

2. If pump does not begin to pump water after a few minutes, check for loose connections or air leaks in suction hose. Make sure there is water in the pump end and strainer is not clogged with debris, reference Table 8 (Pump Troubleshooting).
3. Slow down the engine and allow to cool for at least 2 minutes. Place **speed control lever** in the stop position and listen for the engine to stop running.

### Engine Shut-Down

1. Slow down the engine and allow to cool for at least 2 minutes. Place **speed control lever** in the idle position and turn the ignition key to the **OFF** position.

#### **CAUTION**

**NEVER** attempt to stop the engine by moving the decompression lever. Always use the speed control lever to stop engine.

2. Turn the ignition key to the **0** position and remove the key from the ignition switch.

#### **CAUTION**

When pump is not in use, keep ignition starting key in a safe place, out of the reach of unauthorized persons.

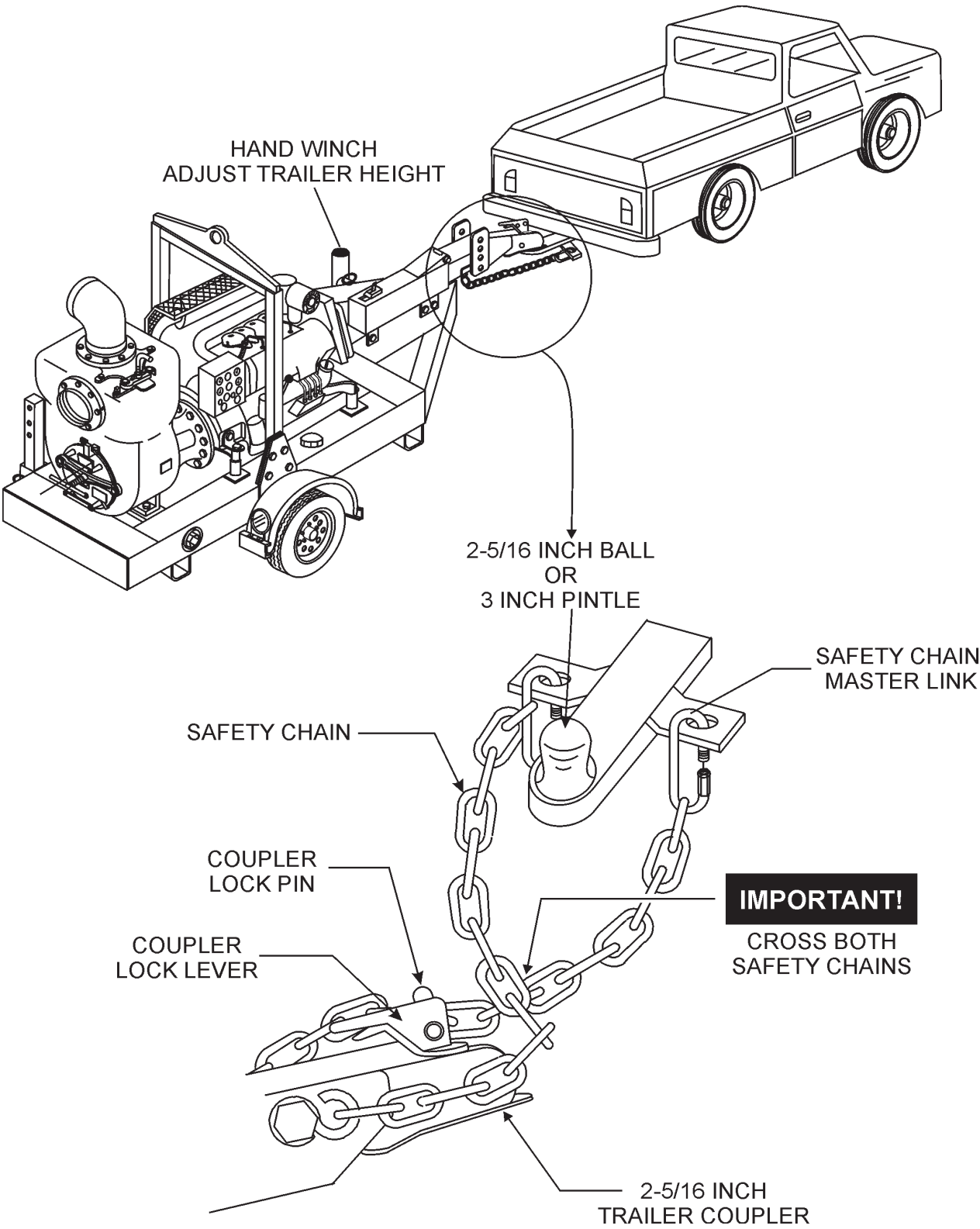

Figure 10. Safety Chains/Trailer Coupler Hook-up

## Trailer Safety Precautions

### CAUTION

**ALWAYS** make sure that the trailer is in good operating condition. Check the tires for proper inflation and wear. Also check the wheel lug nuts for proper tightness. Reference Figure 10 for proper towing safety guidelines.

This section is intended to provide the user with trailer service and maintenance information. The service and maintenance guidelines referenced in this section apply only to the trailer used with the MQ600TD and is intended for no other trailer. Remember periodic inspection of the trailer will ensure safe towing of the equipment and will prevent damage to the equipment and personal injury.

It is the purpose of this section to cover the major maintenance components of the trailer. The following trailer components will be discussed in this section:

- Brakes
- Tires
- Lug Nut Torquing
- Suspension
- Electrical
- Brake Troubleshooting Tables

## Terms To Know

1. **Braking System** – System employed in stopping the trailer. Typical braking systems used on this trailer is hydraulic.
2. **GVWR** – Gross Vehicle Weight Rating (**GVWR**), is the maximum number of pounds the trailer can carry, including the fuel tank (empty). The GVWR of this trailer is 3,060 lbs. (1,388 Kg.).
3. **Coupler** – Type of hitch used on the trailer for towing. Use either a 2-5/16 inch ball hitch or pintle ball hitch.
4. **Tires Size** – This trailer uses 14 inch tires. The tire diameter must match the diameter of the tire rim.
5. **Tires Ply** – The tire ply (layers) number is rated in letters; This trailer uses 4-ply tires.
6. **Wheel Hub** – The wheel hub is connected to the trailer's axle. **ALWAYS** make sure that the wheel is securely attached to the hub. See Table 7 and Figure 12 for lug nut tightening and sequence.
7. **Tire Rim** – Tires are mounted on a rim. The rim must match the size of the tire. **ALWAYS** use tires of proper size and rated capacity.
8. **Lug Nuts** – Used to secure the wheel to the wheel hub. Always use a torque wrench to tighten down the lug nuts. See Table 7 and Figure 21 for lug nut tightening and sequence.
9. **Axle** – Indicates the maximum weight the axle can support in pounds This trailer can support a maximum weight of 3,500 lbs. (1,588 Kg.).
10. **Suspension** – Protects the trailer chassis from shocks transmitted through the wheels. This trailer uses an **torsion bar** type suspension
11. **Electrical** – Electrical connectors (looms) are provided with the trailer so that brake lights and turn signal lights can be connected to the towing vehicle. See Figure 13 for proper wiring connections.

## Hydraulic Brakes

If your trailer has a braking system, the brakes should be inspected the first 200 miles of operation. This will allow the brake shoes and drums to seat properly. After the first 200 mile interval, inspect the brakes every 3,000 miles. If driving over rough terrain inspect brakes more frequently.

Normally Hydraulic brakes should not require any special attention with the exception of routine maintenance such as shoe and lining replacement. These brakes can be adjusted in the same manner as electric brakes. Brake lines should be periodically checked for cracks, kinks, or blockage.

Figure 11 display's the major hydraulic brake components that will require inspection and maintenance. Please inspect these components as required using steps 1 through 7 Reference Table 10 for hydraulic brake troubleshooting guidelines.

## Hydraulic Brake Adjustment

1. Place the trailer on jack stands. Make sure that the jack stands are placed on secure level ground.
2. Check the wheel and drum for free rotation.
3. Remove the adjusting hole cover from the adjusting slot at the bottom brake backing plate.
4. With a screwdriver or standard adjusting tool, rotate the star wheel of the adjuster assembly to expand the brake shoes.
5. Adjust the brake shoes outward until the pressure of the lining against the wheel drum makes the wheel difficult to turn.
6. Rotate the star wheel in the opposite direction until the wheel rotates freely with slight lining drag.
7. Replace the adjusting hole cover and lower the trailer to the ground.
8. Repeat steps 1 through 6 on the remaining brakes.

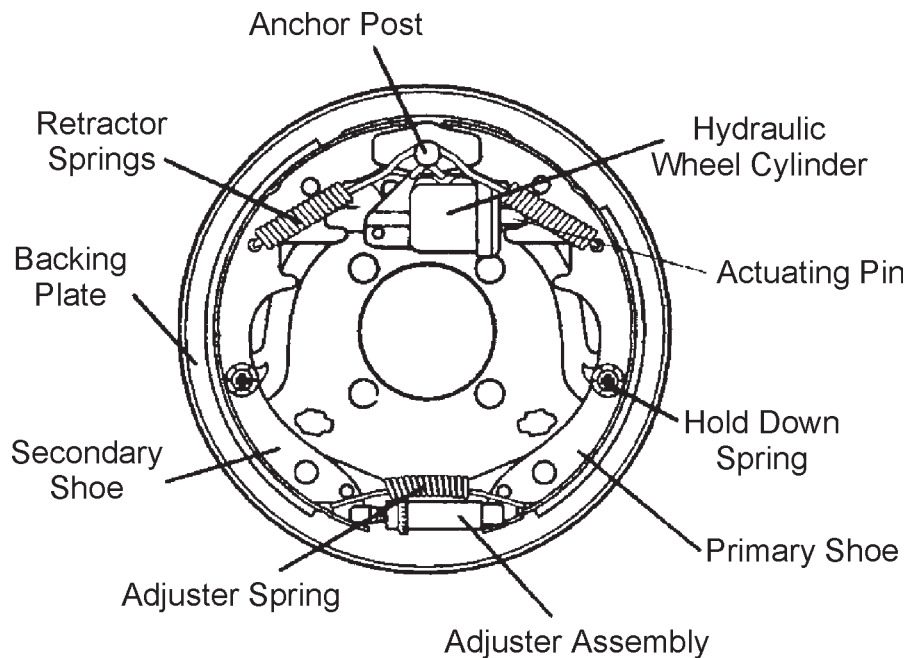

Figure 11. Hydraulic Brake Components

## Tires/Wheels/Lug Nuts

Tires and wheels are a very important and critical components of the trailer. When specifying or replacing the trailer wheels it is important the wheels, tires, and axle are properly matched.

### CAUTION

**DO NOT** attempt to repair or modify a wheel. **DO NOT** install an inter-tube to correct a leak through the rim. If the rim is cracked, the air pressure in the inter-tube may cause pieces of the rim to explode (break-off) with great force and can cause serious eye or bodily injury.

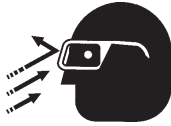

## Tires Wear/Inflation

Tire inflation pressure is the most important factor in tire life. Pressure should be checked cold before operation. **DO NOT** bleed air from tires when they are hot. Check inflation pressure weekly during use to insure the maximum tire life and tread wear.







Table 6 (Tire Wear Troubleshooting) will help pinpoint the causes and solutions of tire wear problems.

### CAUTION

**ALWAYS** wear safety glasses when removing or installing force fitted parts. Failure to comply may result in serious injury.



**TABLE 6. TIRE WEAR TROUBLESHOOTING**

WEAR PATTERN		CAUSE	SOLUTION
	Center Wear	Over Inflation	Adjust pressure to particular load per tire manufacturer.
	Edge Wear	Under Inflation	Adjust pressure to particular load per tire manufacturer.
	Side Wear	Loss of chamber or overloading.	Make sure load does not exceed axle rating. Align wheels.
	Toe Wear	Incorrect toe-in	Align wheels.
	Cupping	Out-of balance	Check bearing adjustment and balance tires.
	Flat Spots	Wheel lockup & tire skidding.	Avoid sudden stops when possible and adjust brakes.

## Lug Nut Torque Requirements

It is extremely important to apply and maintain proper wheel mounting torque on the trailer. Be sure to use only the fasteners matched to the cone angle of the wheel. Proper procedure for attachment of the wheels is as follows:

1. Start all wheel lug nuts by hand.
2. Torque all lug nuts in sequence. See Figure 11. **DO NOT** torque the wheel lug nuts all the way down. Tighten each lug nut in 3 separate passes as defined by Table 7.

**Table 7. Tire Torque Requirements**

Wheel Size	First Pass FT-LBS	Second Pass FT-LBS	Third Pass FT-LBS
12"	20-25	35-40	50-65
13"	20-25	35-40	50-65
14"	20-25	50-60	90-120
15"	20-25	50-60	90-120
16"	20-25	50-60	90-120

3. After first road use, retorque all lug nuts in sequence. Check all wheel lug nuts periodically.

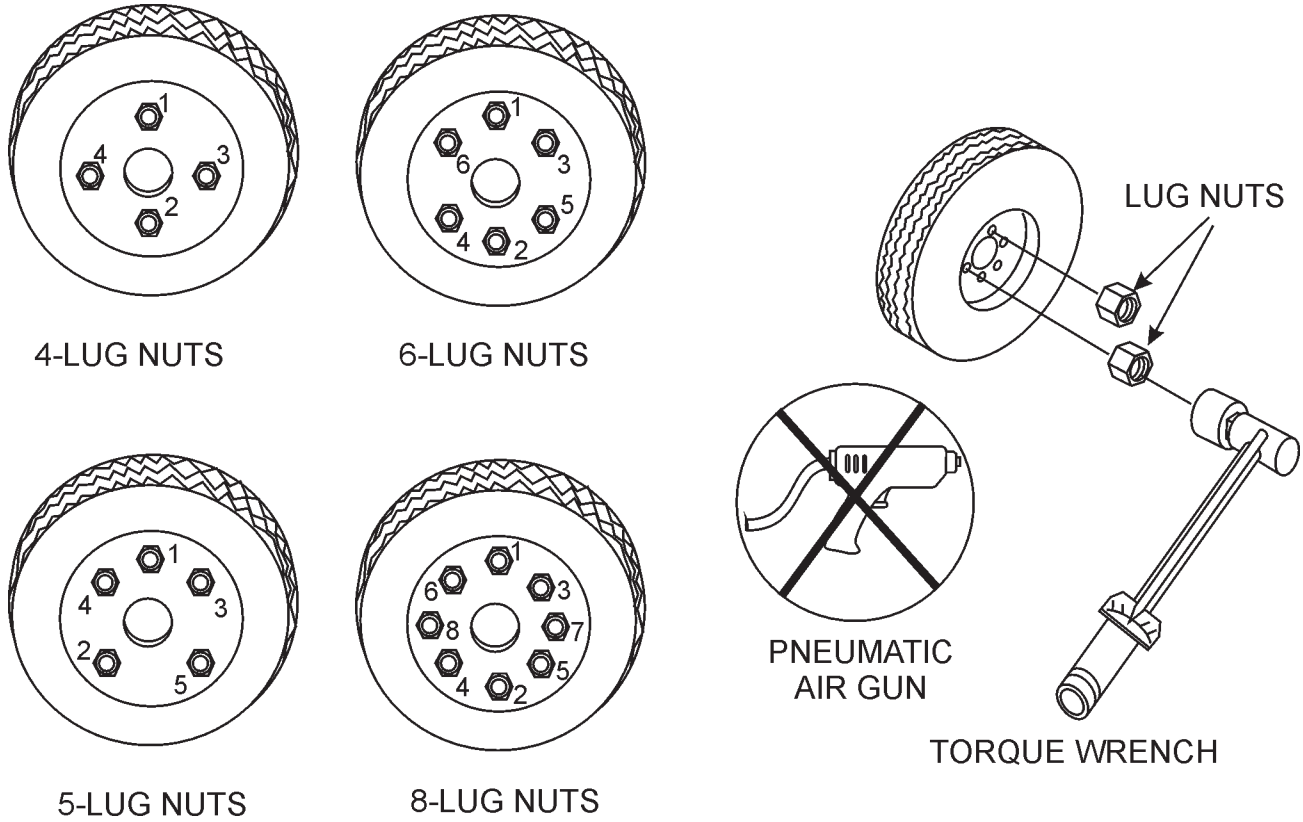
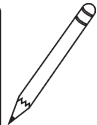
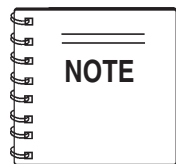

Figure 12. Wheel Lug Nuts Tightening Sequence



**NEVER!** use an pneumatic air gun to tighten wheel lug nuts.

# MQ600TD80 — TRAILER WIRING DIAGRAM

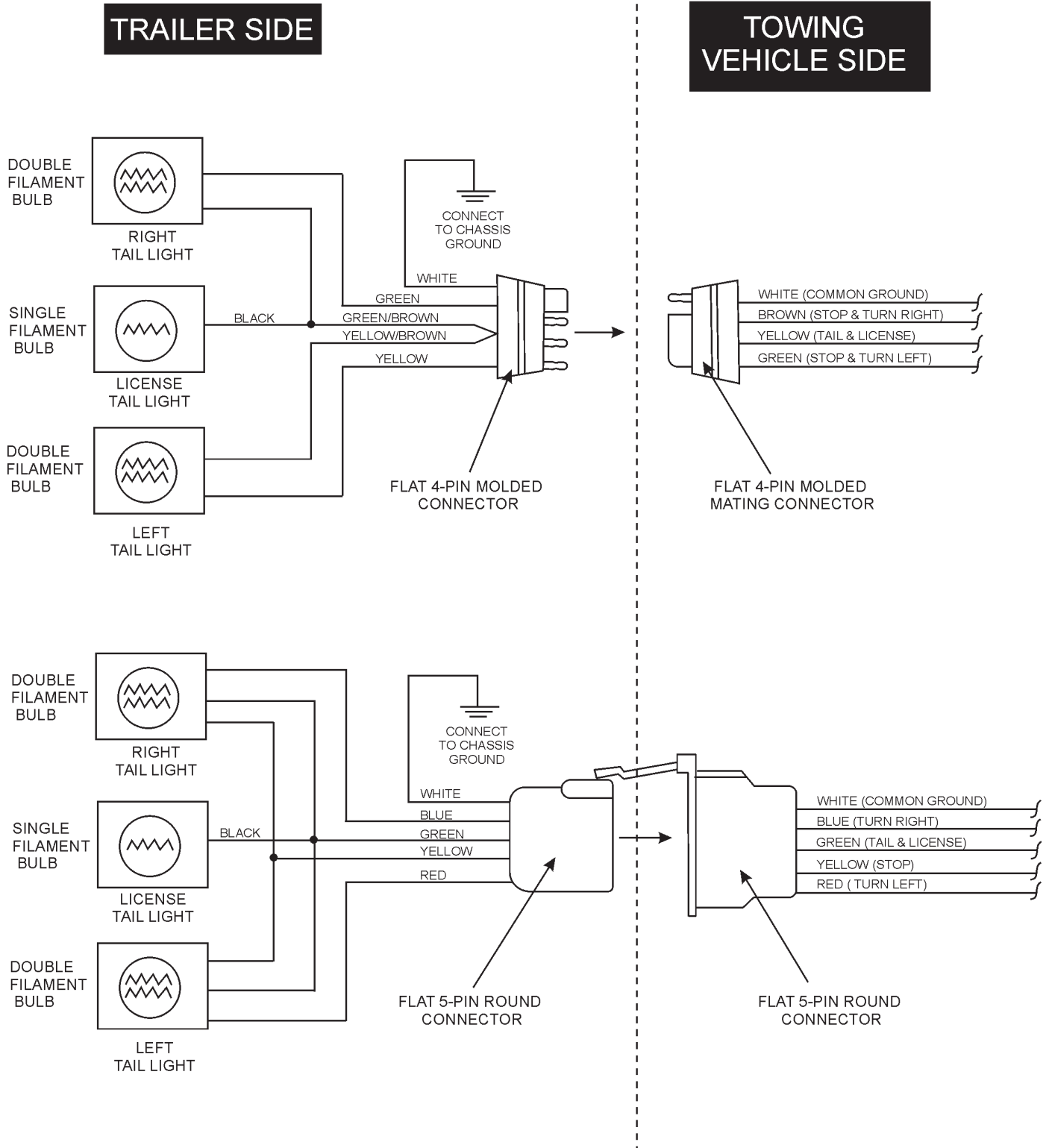

Figure 13. Typical Trailer Wiring Diagram

NOTE:  
LIGHTS ARE ORIENTED FROM THE DRIVER'S SEAT

## General Inspection

The following maintenance guidelines are intended to assist the operator in preventative maintenance. For a more detailed maintenance schedule refer to the **Deutz Engine Instruction Manual** supplied with the pump.

At least **daily** or prior to each use, the MQ600TD80 trash pump cover should be removed, and the pump should be cleaned and inspected for deficiencies. Check for loose, missing or damaged nuts, bolts or other fasteners. Also check for fuel or oil leaks, and remove any debris stuck in the impeller or volute.

## Check Oil Level

Check the engine crankcase oil level prior to each use, or when the fuel tank is filled. Make sure the pump is level. The oil level must be between the two notches on the dipstick as shown in Figure 14.

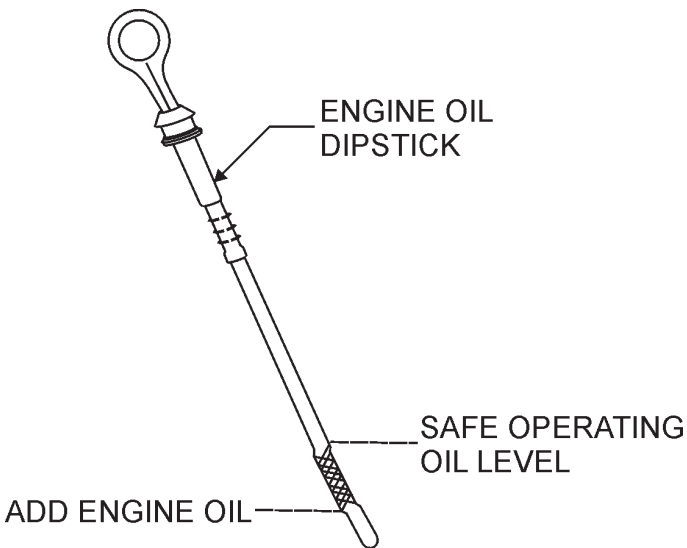

**Figure 14. Engine Oil Dipstick**

## Changing Engine Oil

Change engine oil after first 20 hours of operation. Drain and refill engine crankcase with the correct type and amount oil (reference Table 5) after 250 hours of operation hours or once a week thereafter.

When draining engine crankcase oil, place oil into a suitable container while engine is still warm. Replace the drain plug tightly. Add oil through the filler hole

## Changing Oil Filter

Change the Deutz engine oil filter (Figure 15) after 250 hours of operation.



**Figure 15. Oil Filter Element**

## Fuel Filter System

The Deutz engine fuel system incorporates four different types of fuel filters, in-line, easy change, IMSA, and a fuel water separator.

### In-line Fuel Filter

Replace the in-line fuel filter (Figure 16) every 500 hours. If the purity of the fuel being used is of lesser quality replace the in-line fuel filter more often as needed

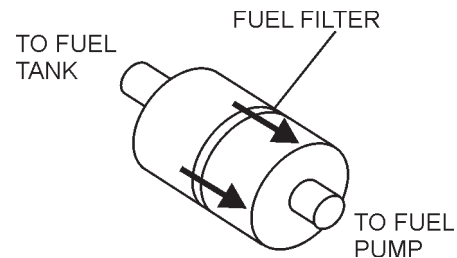

**Figure 16. In-Line Fuel Filter**

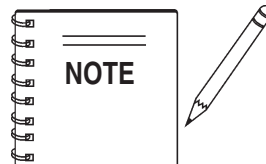

When reinstalling fuel filters, please note the arrows indicating the **direction of fuel flow**.

## Easy-Change Fuel Filter

Replace the easy change fuel filter (Figure 17) every 500 hours.



Figure 17. Easy-Change Fuel Filter

## IMSA Fuel Filter

Inspect and clean (replace if necessary) the IMSA fuel filter (Figure 18) every 500 hours. This filter is part of the fuel pump.

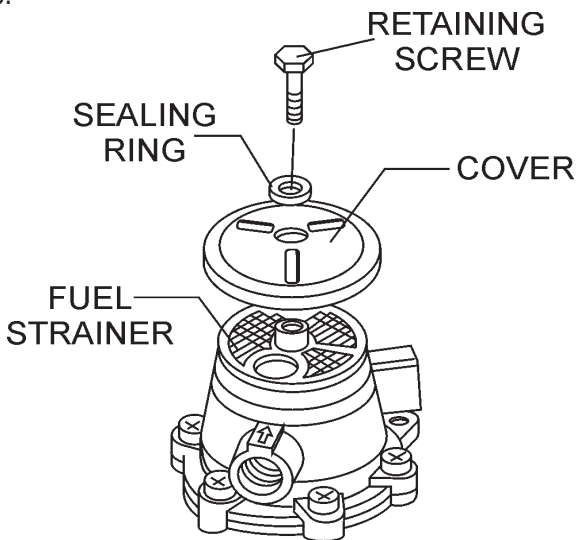

Figure 18. IMSA Fuel Filter

## Cleaning the IMSA Fuel Filter

1. Close the fuel shut-off valve and loosen the retaining on the IMSA fuel filter (Figure 18).
2. Remove the cover and the fuel strainer.
3. Clean the fuel strainer with diesel fuel. Replace fuel strainer if necessary.
4. Re-assemble IMSA fuel filter.
5. Bleed fuel system and check for fuel leaks.

## Fuel Water Separator Filter

1. Inspect the fuel water separator (Figure 19) every 40 hours. If the fuel water separator requires maintenance follow steps 2 and 3 below:

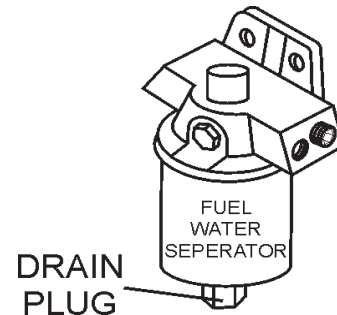

Figure 19. Fuel Water separator Filter

2. Open the drain plug on the fuel water separator (Figure 18) to remove any sediment or water that may have accumulated in the fuel water separator reservoir.
3. After water and sediment and foreign debris has been drained from the fuel water separator, re-install the drain plug on fuel water separator.

## Fuel Tank

Unscrew the fuel drain plug on the fuel tank (Figure 20) to remove water and sediment every 500 hours. If the purity of the fuel being used is of lesser quality drain the fuel tank more frequently.

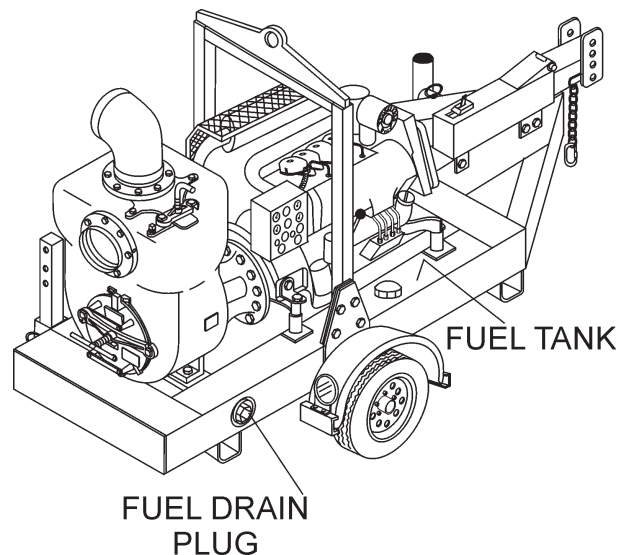

Figure 20. Fuel Tank/Drain Plug

## Pump Vacuum Test



### CAUTION

**DO NOT** attempt to start the engine unless the pump has previously been **primed** with water. Severe pump damage will occur if pump has not been primed.

To perform the pump vacuum test do the following:

1. Remove the pump fill cap, and fill the pump with water.
2. Start the engine as outlined in the initial start-up section, and wait for the pump to begin pumping. Confirm engine is operating at 1,900 RPM's
3. As shown in Figure 20 (next page), place a water hose inside the discharge opening of the pump, and turn on the water. This flow of water into the discharge opening will **prevent** the pump from running dry.
4. Place the **Pump Vacuum Tester** over the pump inlet opening (Figure 21) with the vacuum gauge facing upwards. It may be necessary to apply a small amount of water around the rubber seal of the vacuum tester to make a good suction fit.

5. Check and make sure that there are no air leaks between the vacuum tester and the inlet port on the pump. If air leaks are present re-seat vacuum tester.
6. Run the pump for a few minutes while monitoring the vacuum gauge. A pump will lose approximately one foot of suction lift for every 1,000 feet of elevation. Depending on the elevation, the gauge should read between 20-29 in. Hg. (inches of mercury). This is an indication that the pump is working correctly.
7. If the vacuum tester gauge indicates a reading **below** -20 in. Hg, it can then be assumed that the pump is not functioning correctly, and corrective action needs to be taken.

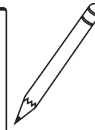
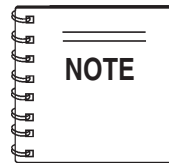

25 in. Hg (inches of mercury) translates into 25 feet of lift at **sea level**.

**CAUTION**

DO NOT RUN PUMP  
WITHOUT WATER.

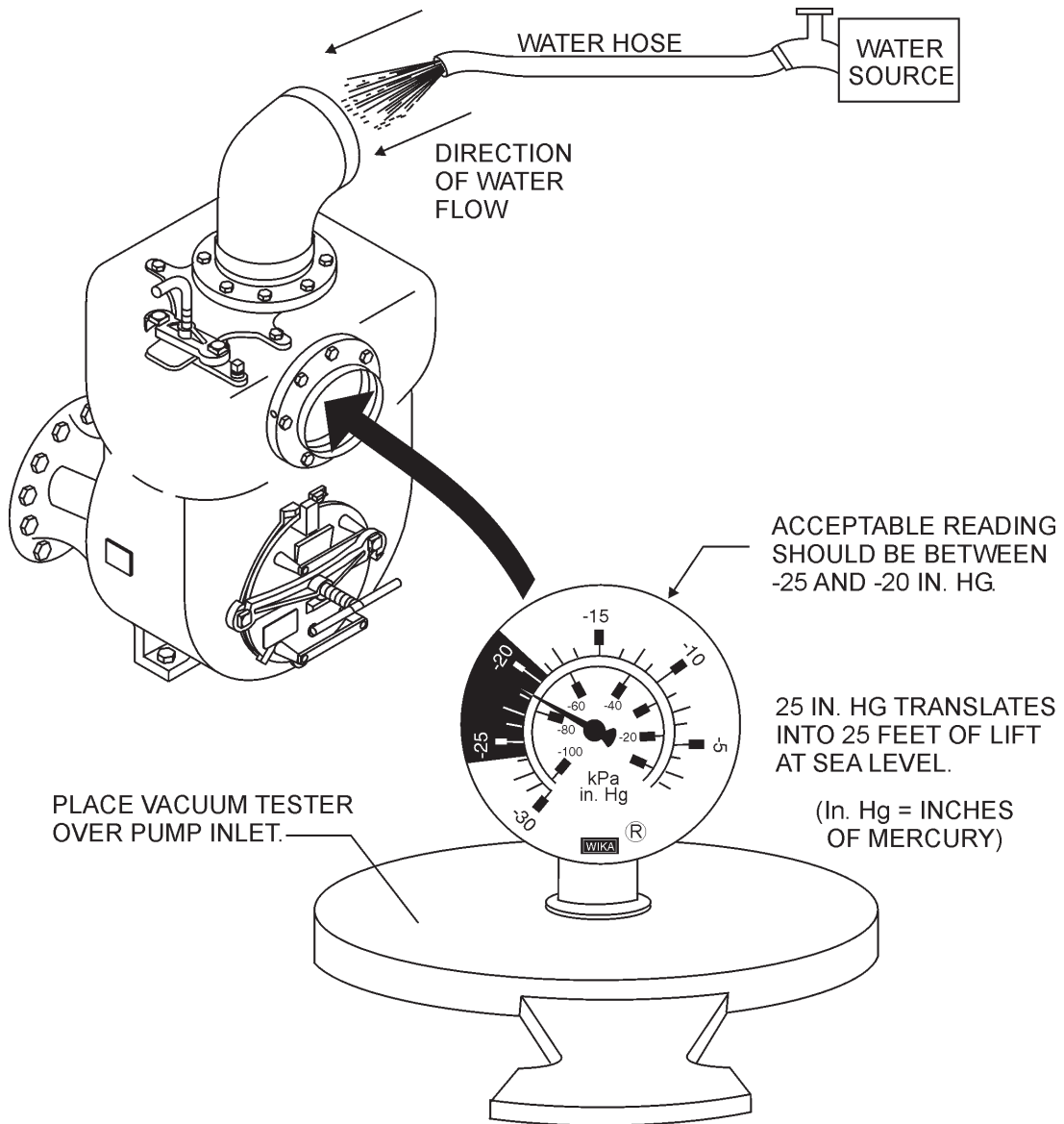

PUMP VACUUM TESTER

Figure 21. Pump Vacuum Tester

## Pump Storage

For storage of the pump for over 30 days, the following is required:

- Drain the fuel tank completely.
- Run the engine until the fuel in the injection system is completely consumed.
- Completely drain used oil from the engine crankcase and fill with fresh clean oil, then follow the procedures described in the engine manual for engine storage.
- Remove the drain plug from the pump and drain out any water from left in the housing.
- Remove the pump cover and clean inside of pump housing. Coat inside of pump housing with a light film of oil to reduce corrosion. A spray can of oil works well for this application.
- Cover suction and discharge ports with duct tape to prevent any foreign matter from falling into pump.
- Cover pump and engine with plastic covering or equivalent and store in a clean, dry place.

## MQ600TD80 — TROUBLESHOOTING (PUMP)

Practically all breakdowns can be prevented by proper handling and maintenance inspections, but in the event of a breakdown, please take a remedial action following the diagnosis based on the Troubleshooting (Tables 8, 9 and 10) information shown below and on the next pages. If the problem cannot be remedied, please leave the unit just as it is and consult our company's business office or service plant.

**TABLE 8. PUMP TROUBLESHOOTING**

SYMPTOM	POSSIBLE PROBLEM	SOLUTION
Pump does not take on water.	Not enough priming water in the housing?	Add water.
	Engine speed too low?	Increase throttle.
	Strainer plugged?	Clean strainer.
	Suction hose damaged?	Replace or repair hose, and clamps
	Air leak at suction port?	Check that fittings are tight and properly sealed.
	Pump is located too high above water line?	Move pump closer to water.
	Debris collecting in pump housing?	Clean pump housing.
	Too much distance between impeller and wear plate.	Adjust clearance by adding shims or replace impeller. Min. .010" - Max. .020
	Water leaking out weep hole between pump and engine?	Check condition of mechanical seal and gaskets, between pump end and engine housing.
Suction lift or discharge head too high.	Check hose/pipe installation.	
Pump takes in water, little or no discharge.	Engine speed too low?	Increase throttle speed.
	Suction strainer partially plugged?	Clean strainer.
	Impeller/Wear Plate worn?	Adjust clearance by adding shims or replace impeller/wear plate.
Suction hose leaks at inlet.	Fittings/clamps are not sealed properly?	Tighten, replace or add clamp. (Keep extra seals on pump)
	Hose diameter is too large?	Use smaller diameter hose or replace hose.
Discharge does not stay on coupling.	Pressure too high?	Check pressure, add additional clamp.
	Hose kinked or end blocked?	Check hose.
Impeller does not turn: pump is hard to start.	Impeller jammed or blocked?	Open pump cover and clean dirt and debris from inside housing.
	Impeller and wear plate binding?	Adjust clearance by removing shim from behind impeller.
	Defective engine?	See Deutz Engine Owner's Manual.

# MQ600TD80 — TROUBLESHOOTING (ENGINE)

**TABLE 9. ENGINE TROUBLESHOOTING**

SYMPTON	POSSIBLE PROBLEM	SOLUTION
Engine will not start or start is delayed, although engine can be turned over.	Speed control lever is in "STOP" position?	Set speed control lever to "START" position.
	STOP solenoid is in the "STOP" position?	Set stop solenoid to the "START" position. Adjust and lubricate if necessary.
	No Fuel reaching injection pump?	Add fuel. Check entire fuel system.
	Defective fuel pump?	Replace fuel pump.
	Fuel filter clogged?	Replace fuel filter and clean tank.
	Faulty fuel supply line?	Replace or repair fuel line.
	Compression too low?	Check piston, cylinder and valves. Adjust or repair per engine repair manual.
	Fuel injector not working correctly?	Repair or replace injector in accordance with engine repair manual.
	Oil pressure too low?	Check engine oil pressure.
	Low starting temperature limit exceeded	Comply with cold starting instructions and proper oil viscosity.
Defective battery?	Charge or replace battery.	
At low temperatures engine will not start.	Fuel separates has inadequate resistance to low temperatures?	Check whether clear (not turbid) fuel emerges from the fuel line (detach from injection pump). If the fuel is turbid or separated either, warm up the engine or drain the complete fuel supply system. Refuel with winter grade diesel fuel.
	Engine oil too thick?	Refill engine crankcase with correct type of oil for winter environment.
	Defective battery?	Replace battery.
Engine fires but stops soon as starter is switched off.	Throttle lever in STOP position?	Reposition throttle lever to RUN position.
	Fuel filter blocked?	Replace fuel filter.
	Fuel supply blocked?	Check the entire fuel system.
	Electrical problem at fuel solenoid?	Repair using #7 wire.
Engine stops by itself during normal operation.	Fuel tank empty?	Add fuel.
	Fuel filter blocked?	Replace fuel filter.
	Defective fuel pump?	Replace fuel pump.
	Mechanical oil pressure shutdown sensor stops the engine due to low oil?	Add oil. Replace low oil shutdown sensor if necessary.

# MQ600TD80 — TROUBLESHOOTING (ENGINE)

**TABLE 9. ENGINE TROUBLESHOOTING (CONTINUED)**

SYMPTON	POSSIBLE PROBLEM	SOLUTION
Low engine power, output and speed.	Fuel tank empty?	Replace fuel filter.
	Fuel filter clogged?	Replace fuel filter.
	Fuel tank venting is inadequate?	Ensure that tank is adequately vented.
	Leaks at pipe unions?	Check threaded pipe unions tape and tighten unions as required.
	Speed control lever does not remain in selected position?	See engine manual for corrective action.
	Engine oil level too full?	Correct engine oil level?
Low engine power output and low speed, black exhaust smoke.	Air filter blocked?	Clean or replace air filter.
	Incorrect valve clearances?	Adjust valves per engine specification.
	Malfunction at injector?	See engine manual.
Air-cooled diesel engine runs very "HOT". Cylinder head overheat, telltale lamp comes on (option)	Too much oil in engine crankcase?	Drain off engine oil down to uppermark on dipstick.
	Entire cooling air system contaminated blocked?	Clean cooling air system, remove shrouds and cooling fin areas.
	Inadequate sealing at air guide plates or capsule elements?	Check that air guide plates and enclosure elements are all present and make a tight seal.

## TABLE 10. HYDRAULIC BRAKE TROUBLESHOOTING

SYMPTON	POSSIBLE CAUSE	SOLUTION
No brakes	Is the brake line broken or kinked?	Repair or replace.
Weak brakes or brakes pull to one side.	Is the brake lining glazed?	Reburnish or replace
	Is the trailer overloaded?	Correct weight.
	Are the brake drums scored or grooved?	Machine or replace.
	Is the tire pressure correct?	Inflate all tires equally per manufacturer guidelines.
	Are the tires unmatched on the same axle?	Match tires.
Locking brakes.	Are the brake components loose, bent or broken?	Replace components.
	Are the brake drums out-of-round?	Replace.
Noisy brakes.	Is the brake system lubricated?	Lubricate.
	Are the correct brake components installed?	Replace and correct.
Dragging brakes.	Is the brake lining thickness correct or innstalled incorrectly?	Install new shoes and linings.
	Is there enough brake fluid or correct fluid?	Fill with dot 4 fluid.



## EXPLANATION OF CODE IN REMARKS COLUMN

How to read the marks and remarks used in this parts book.

### Items Found In the “Remarks” Column

Serial Numbers-Where indicated, this indicates a serial number range (inclusive) where a particular part is used.

Model Number-Where indicated, this shows that the corresponding part is utilized only with this specific model number or model number variant.

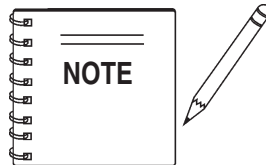

If more than one of the same reference number is listed, the last one listed indicates newest (or latest) part available.

### Items Found In the “Items Number” Column

All parts with same symbol in the number column, \*, #, +, %, or n, belong to the same assembly or kit.

Note: If more than one of the same reference number is listed, the last one listed indicates newest (or latest) part available.

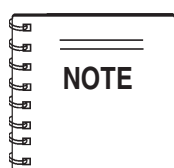

*The contents of this parts catalog are subject to change without notice.*

## MQ600TD80 1 TO 3 UNITS WITH DEUTZ F4L914 ENGINE

### *1 to 3 Units*

Qty.	P/N	Description
3 .....	34488 .....	MECHANICAL SEAL
3 .....	511245 .....	SLEEVE, SEAL (SHAFT)
3 .....	34491 .....	GASKET, FRONT COVER
1 .....	511219 .....	IMPELLER
1 .....	511268 .....	WEAR PLATE
1 .....	34489 .....	FLAP VALVE
1 .....	34493 .....	GASKET
1 .....	511259 .....	OIL SEAL
1 .....	34495 .....	GASKET
1 .....	511261 .....	BEARING
1 .....	511262 .....	BEARING
1 .....	511258 .....	SHAFT
1 .....	511236 .....	OIL SEAL
1 .....	34492 .....	GASKET
3 .....	EM20763 .....	FILTER, FUEL

# MQ600TD80 — NAME PLATE AND DECALS

## NAMEPLATE AND DECALS

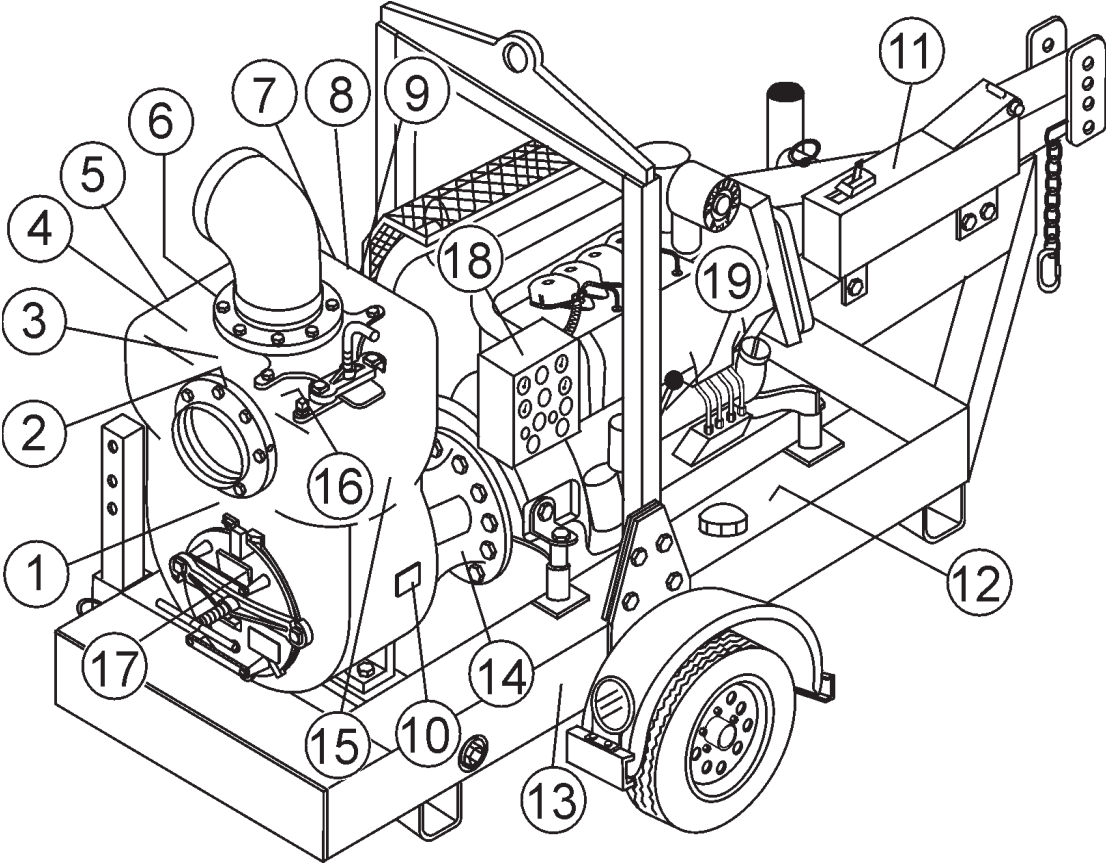

# MQ600TD80 — NAME PLATE AND DECALS

## NAMEPLATE AND DECALS

<u>NO</u>	<u>PART NO</u>	<u>PART NAME</u>	<u>QTY.</u>	<u>REMARKS</u>
1	511782	DECAL: MQ (LONG-WHITE)	1	
2*		DECAL: SUCTION .....	1	DCL130
3*		DECAL: WARNING (DO NOT RUN DRY) .....	1	DCL129
4*		DECAL: WARNING (OPERATION) .....	1	DCL125
5*		DECAL: CAUTION (BEARING/MEC. SEAL) .....	1	DCL133
6*		DECAL: DISCHARGE .....	1	DCL131
7*		DECAL: WARNING (MOVING PARTS) .....	1	DCL135
8*		DECAL: BEARING SIGHT GLASS .....	1	DCL137
9*		DECAL: MEC. SEAL SIGHT GLASS .....	1	DCL138
10		PLATE SERIAL NO .....	1	CONTACT MQ SERVICE DEPT. ..... W/MODEL & S/N
11	TBD	DECAL: TOWING	1	
12	EM995	DECAL: DIESEL FUEL	1	
13*		DECAL: TIRE .....	1	DCL151
14*		DECAL: WARNING (ROTATING IMPELLER) .....	2	DCL128
15	511783	DECAL: MQ (STACKED WHITE)	1	
16*		DECAL: WARNING (FILL CAP) .....	1	DCL126
17*		DECAL: WARNING (SERVICE) .....	1	DCL127
18*		DECAL: WARNING (READ INSTRUCTIONS) .....	1	DCL134
19*		DECAL: RUN FULL THROTTLE .....	1	DCL136
20	34517	KIT, DECAL .....	1	INCLUDES ITEMS W/* ..... DECALS AVAILABLE ONLY AS KIT.

SEE DECAL ILLUSTRATIONS ON PAGES 12 AND 13.

# MQ600TD80 — PUMP IMPELLER, CLEANOUT, & DISCHARGE ASSY.

PUMP IMPELLER, CLEANOUT, & DISCHARGE ASSY.

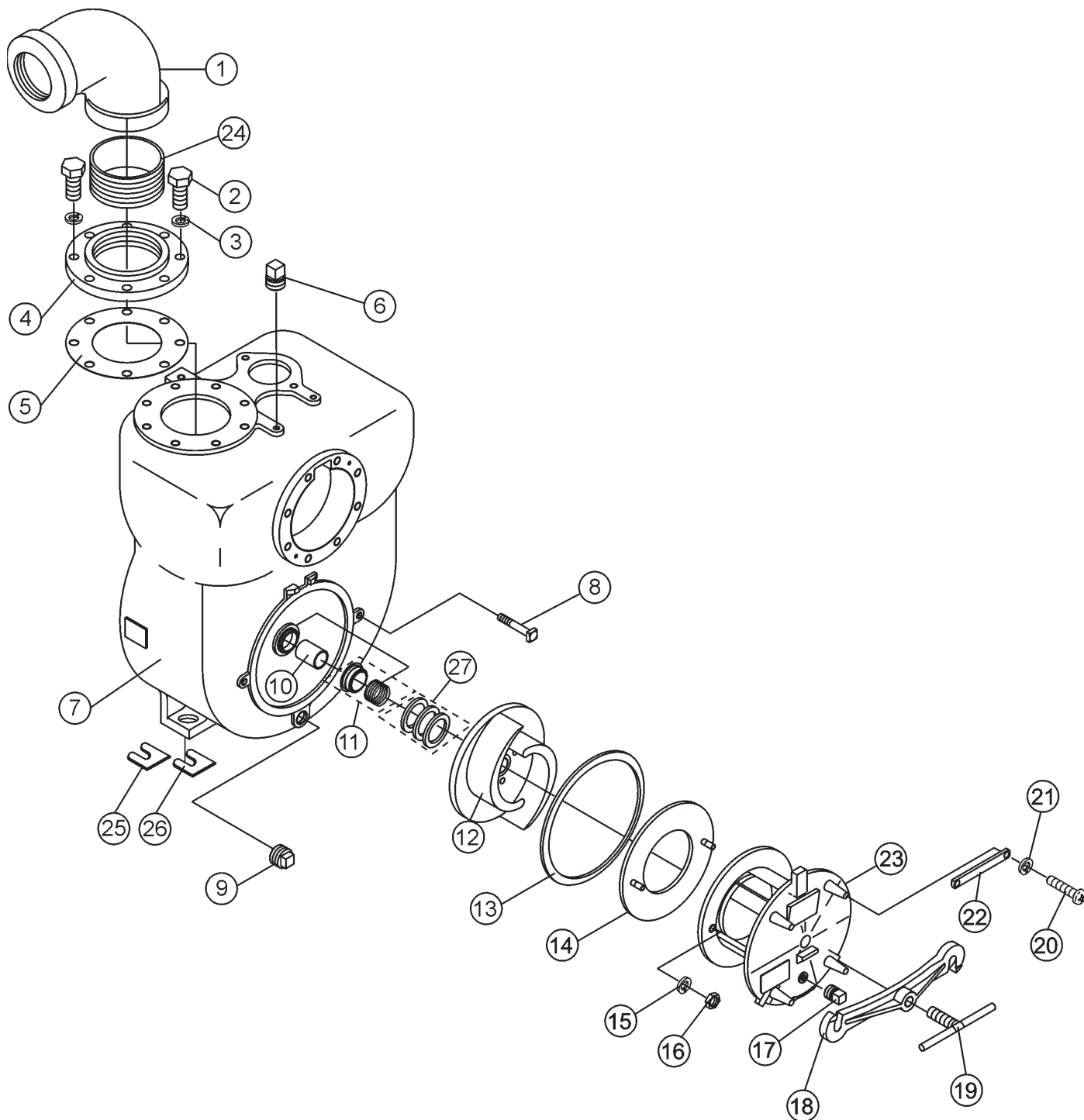

# MQ600TD80 — PUMP IMPELLER, CLEANOUT, & DISCHARGE ASSY.

## PUMP IMPELLER, CLEANOUT, & DISCHARGE ASSY.

<u>NO.</u>	<u>PART NO.</u>	<u>PART NAME</u>	<u>QTY.</u>	<u>REMARKS</u>
1	511223	90 DEGREE ELBOW	1	
2	509078	HHCS 3/4 X 2 G5	8	
3	492628	LOCK WASHER 3/4	8	
4	511225	RETAINER	1	
5	34496	GASKET	1	
6	511220	PIPE NIPPLE	1	
7	511217	MAIN HOUSING	1	
8	511832	MACHINE BOLT	2	
9	505988	DRAIN PLUG	1	
10	511245	SLEEVE, SEAL (SHAFT)	1	
11	34488	MECHANICAL SEAL ASSY.	1	
12	511219	IMPELLER	1	
13	34491	GASKET	1	
14	511268	WEAR PLATE	1	
15	511302	LOCK WASHER	2	
16	508704	NUT	2	
17	491210	DRAIN PLUG NPT1/4	1	
18	511276	RETAINING BAR	1	
19	511837	LOCK BOLT, FRONT COVER	1	
20	506596	HEX HEAD BOLT M8 X 25	4	
21	506597	LOCK WASHER M8	4	
22	506308	HANDLE	2	
23	511272	FRONT COVER	1	
24	511221	6-INCH NPT NIIPPLE	1	
25	511838	SHIM, BASE 0.5 MM	AR	
26	511839	SHIM, BASE 1.0 MM	AR	
27	511244	SHIM, KIT, IMPELLER	AR	

# MQ600TD80 — PUMP SUCTION SIDE ASSY.

PUMP SUCTION SIDE ASSY.

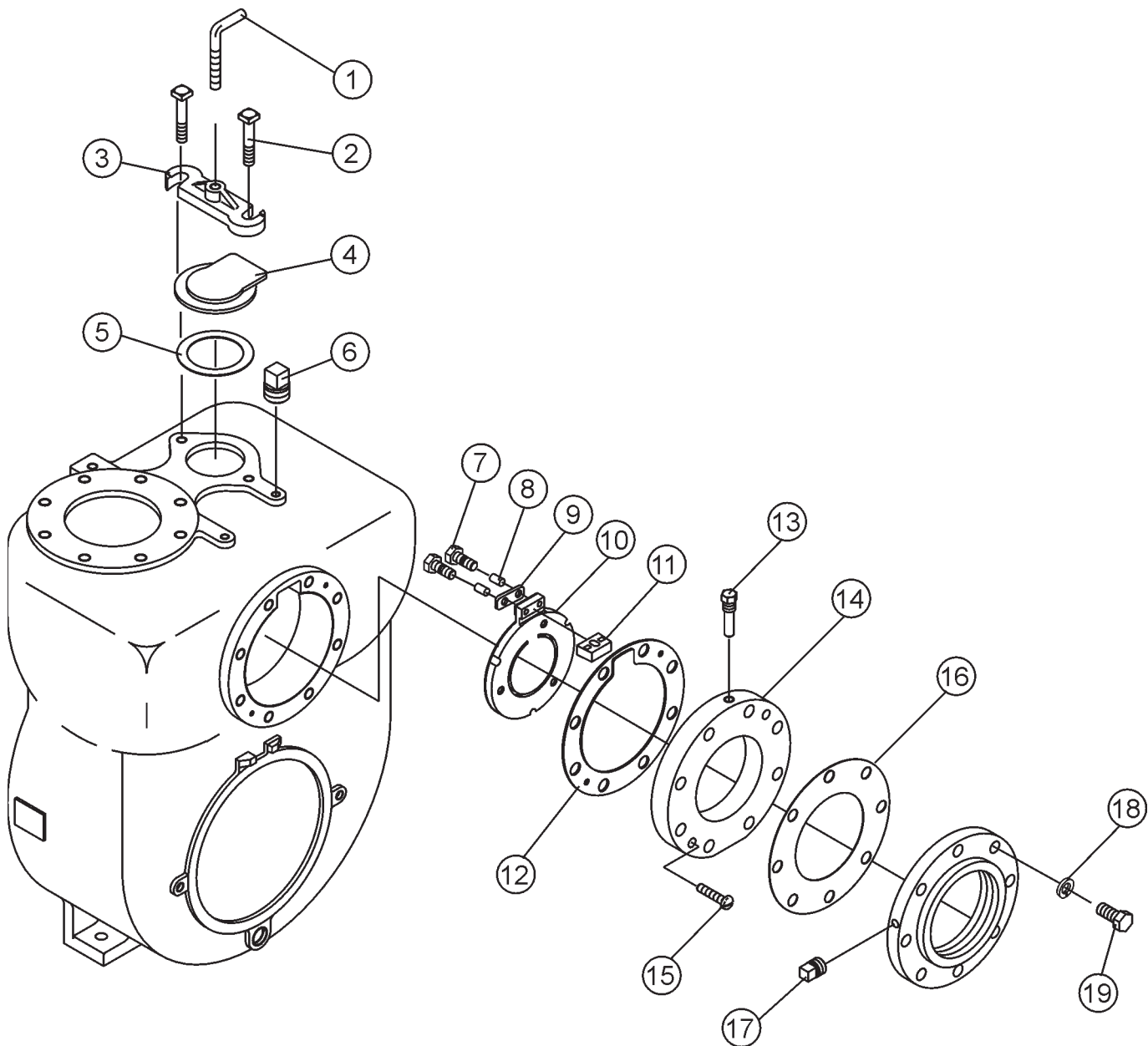

## MQ600TD80 — PUMP ASSY. (CONTINUED)

### PUMP SUCTION SIDE ASSY.

<u>NO.</u>	<u>PART NO.</u>	<u>PART NAME</u>	<u>QTY.</u>	<u>REMARKS</u>
1	511836	LOCK BOLT, FILL	1	
2	511832	MACHINE BOLT	2	
3	511243	RETAINER, FILL	1	
4	511238	COVER, FILL	1	
5	34494	GASKET	1	
6	511220	PIPE NIPPLE	1	
7	511303	HHCS 5/16 X 1-1/4 SS	2	
8	511304	SPACER	2	
9	511305	RETAINER PLATE	1	
10	34489	FLAP VALVE	1	
11	511306	ADAPTER, CHECK VALVE	1	
12	34493	GASKET	1	
13	511307	PIN, CHECK VALVE	1	
14	511278	SEAT, CHECK VALVE	1	
15	511279	SLOT HEAD BOLT 5/16 X 1-1/2	2	
16	34496	GASKET	1	
17	491210	PIPE PLUG NPT 1/4	1	
18	492628	LOCK WASHER 3/4	8	
19	492421	HHCS 3/4 NC X 3-1/2 X G5	8	

# MQ600TD80 — INTERMEDIATE PLATE ASSY.

INTERMEDIATE PLATE ASSY.

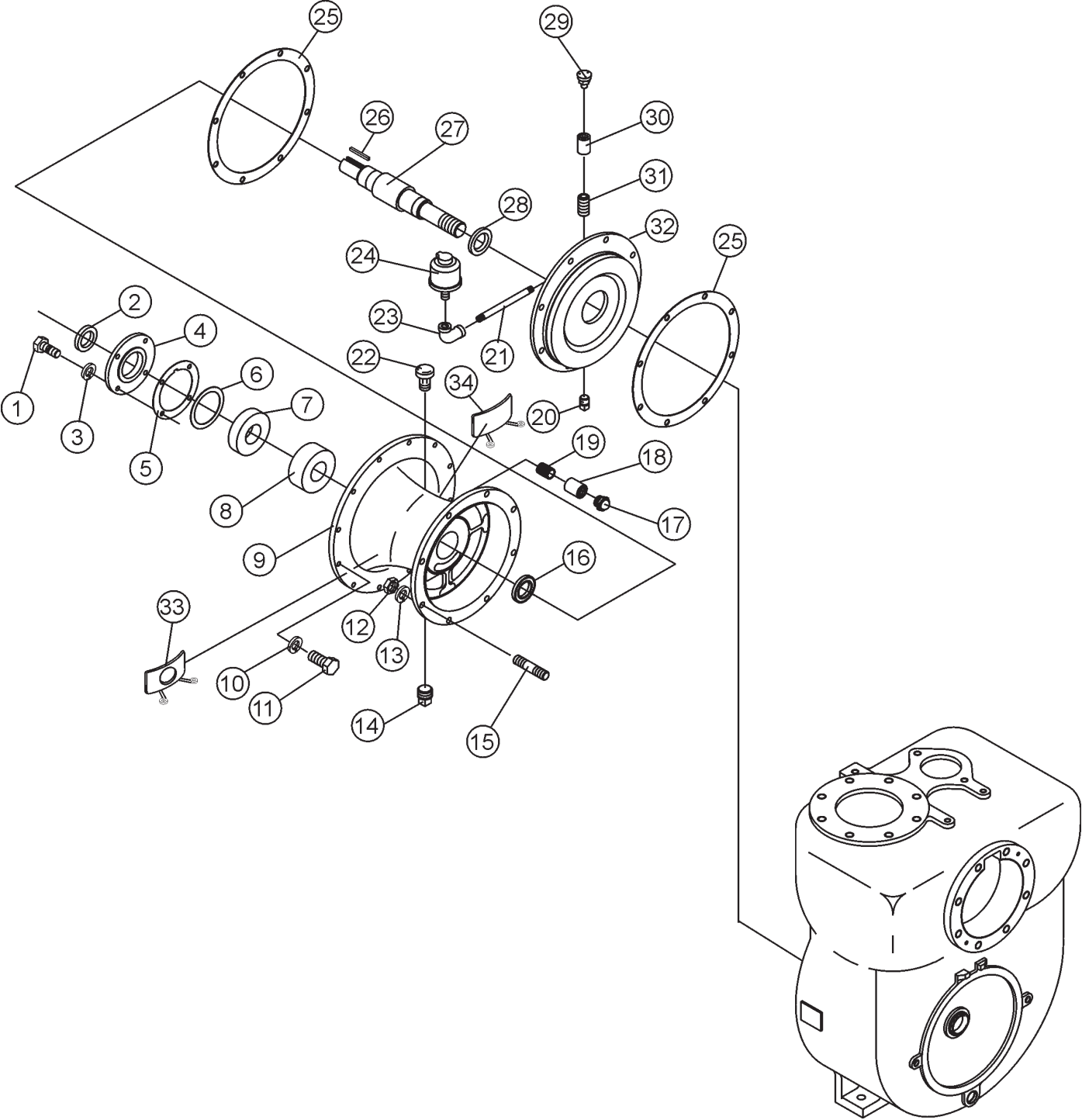

# MQ600TD80 — INTERMEDIATE PLATE ASSY.

## INTERMEDIATE PLATE ASSY.

<u>NO.</u>	<u>PART NO.</u>	<u>PART NAME</u>	<u>QTY.</u>	<u>REMARKS</u>
1	492315	SCREW HHCS 3/8 X2 G2	4	
2	511259	SEAL, OIL	1	
3	0166 A	LOCK WASHER 3/8	4	
4	511256	RETAINER PLATE	1	
5	34495	GASKET	1	
6	34490	WAVE WASHER	1	
7	511261	BEARING	1	
8	511262	BEARING	1	
9	511235	INTERMEDIATE HOUSING	1	
10	EM269	LOCK WASHER	12	
11	EM162	1ALLEN HEAD M10 X 25	12	
12	508704	HEX NUT 1/2 SS	8	
13	511302	LOCK WASHER 1/2 SS	8	
14	507657	DRAIN PLUG	1	
15	511229	STUD	8	
16	511259	SEAL, OIL	1	
17	34502	OIL SIGHT GAUGE	1	
18	506214	PIPE COUPLER	1	
19	511249	PIPE NIPPLE	1	
20	511263	PLUG	1	
21	511248	PIPE NIPPLE	1	
22	511233	BREATHER	1	
23	511833	90 DEGREE ELBOW	1	
24	34501	RESERVOIR OIL, 1 OZ	1	
25	34492	GASKET	1	
26	511257	KEY	1	
27	511258	SHAFT, IMPELLER	1	
28	511236	OIL SEAL	1	
29	511230	BREATHER	1	
30	TBD	PIPE COUPLING NPT 1/8	1	
31	512787	COUPLING, PIPE 1/8	1	
32	511265	ADAPTOR COVER	1	
33	511253	GUARD (BEARING SIGHT GLASS)	1	
34	511252	GUARD	1	

# MQ600TD80 — TRAILER ASSY.

TRAILER ASSY.

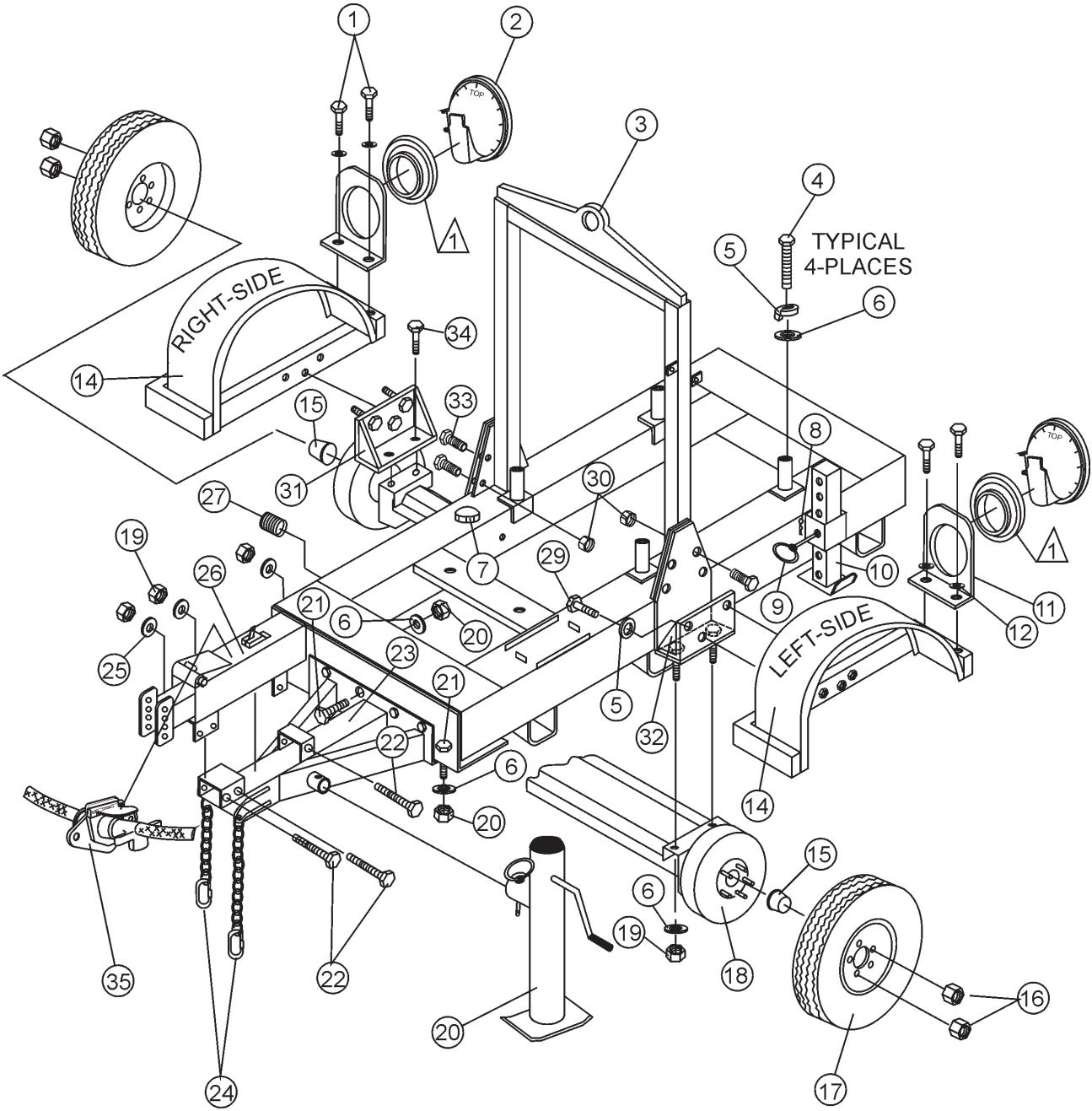

NOTES:  
△ RUBBER LIGHT SEAL IS INCLUDED WITH ITEM 2.

TRAILER ASSY.

<u>NO.</u>	<u>PART NO.</u>	<u>PART NAME</u>	<u>QTY.</u>	<u>REMARKS</u>
1	492363	SCREW, HHC 5/16-18 X 3/4	4	
2	EM26536	LIGHT, TAIL	2	
3	511399	HANGER, FRAME	1	
4	492401	SCREW, HHC 1/2-13 X 4	4	
5	6109180	WASHER, LOCK 1/2	10	
6	EM621	WASHER, FLAT 1/2	4	
7	34507	CAP, FUEL LEVEL INDICATOR	1	
8	745	PIN, COTTER	1	
9	EM744	PIN, JACK STAND	1	
10	EM70186	STAND, TRAILER JACK	1	
11	265361	BRACKET, TAIL LIGHT	2	
12	EM923343	WASHER, LOCK 5/16	4	
13	492363	SCREW, HHC 5/16 X 3/4	4	
14	512356	FENDER, TRAILER	2	
15	26518	CAP, DUST	2	
16	EM26519	LUG NUT	10	
17	EM26615A	WHEEL ASSY.	2	
18	34564	AXLE ASSY.	1	
19	492584	NUT, NYLOC 1/2-13	6	
20	EM25610	JACK, TRALER	1	
21	981635	SCREW, HHC 1/2-13 X 1	9	
22	503111	SCREW, HHC 1/2-13 X 4-1/2	3	
23	512340	TONGUE, TRAILER	1	
24	1005	LINK, CHAIN CONNECTOR	2	
25	492600	WASHER, FLAT 1/2	2	
26	19067	COUPLER, BRAKE	1	
27	505988	PLUG, ALLEN 11-1/2 NPT	2	
29	492394	SCREW, HHC 1/2-13 X 1-1/2	6	
30	492584	NUT, NYLOC 1/2-13	8	
31	512443	BRACKET, RH FENDER MOUNTING	1	
32	512444	BRACKET, LH FENDER MOUNTING	1	
33	492394	SCREW, HHC 1/2 X 1-1/2	8	
34	492396	SCREW, HHC 1/2 X 2	4	
35	512405	LIGHT CABLE HARNESS	1	

# MQ600TD80 — BATTERY/FUEL ASSY.

BATTERY/ FUEL ASSY.

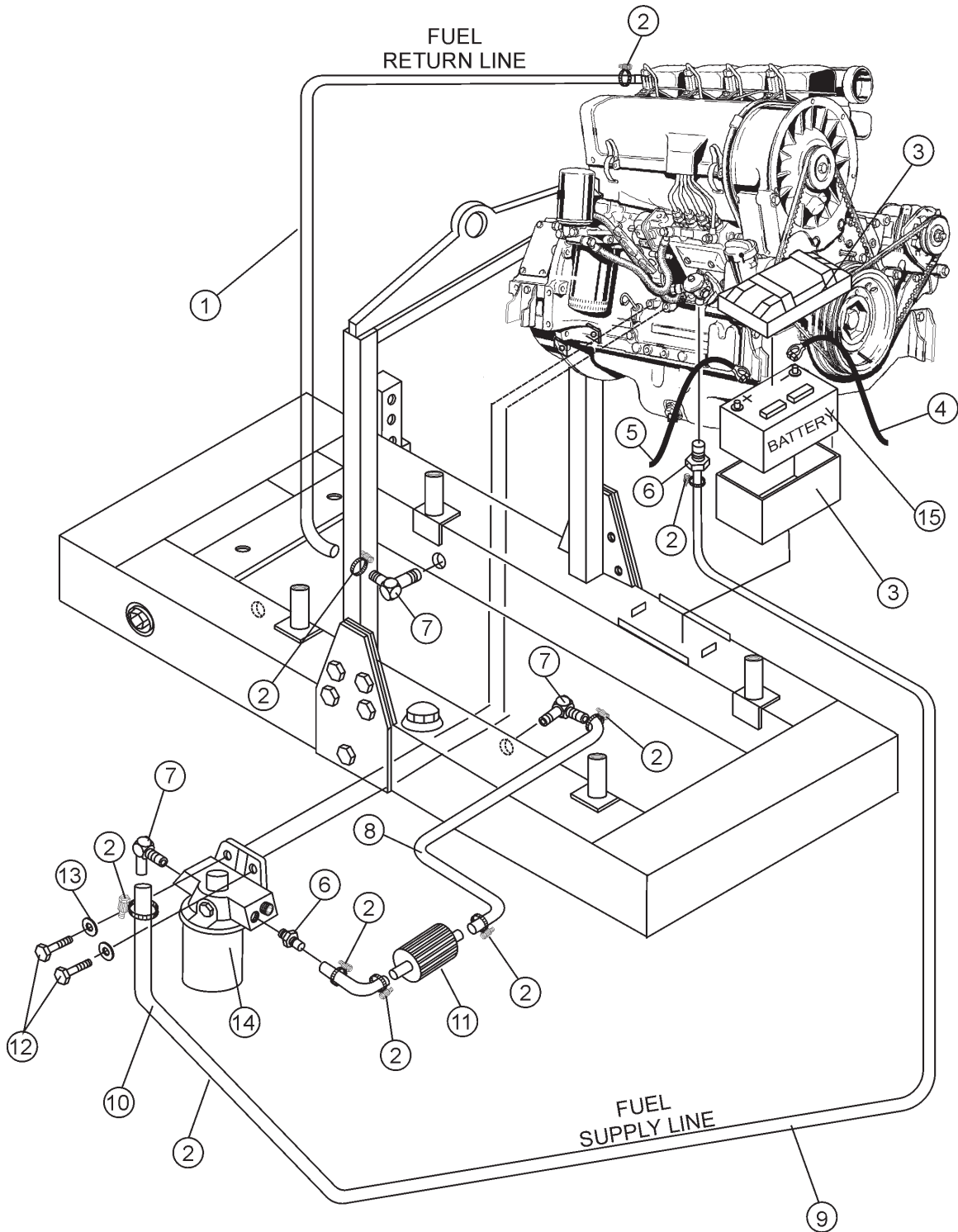

# MQ600TD80 — BATTERY/FUEL ASSY.

BATTERY/ FUEL ASSY.

<u>NO.</u>	<u>PART NO.</u>	<u>PART NAME</u>	<u>QTY.</u>	<u>REMARKS</u>
1	511383	HOSE, FUEL RETURN	1	
2	716	CLAMP, HOSE	8	
3	34506	BOX, BATTERY	1	
4	EM509105	CABLE, BATTERY GROUND	1	
5	EM16707	CABLE, BATTERY POSITIVE	1	
6	511426	ADAPTER, STRAIGHT	2	
7	505521	ADAPTER, ELBOW	4	
8	511382	HOSE, SUPPLY FUEL	1	
9	511831	HOSE, SUPPLY FUEL	1	
10	511403	HOSE, SUPPLY FUEL	1	
11	EM20763	FILTER, FUEL	1	
12	506596	SCREW, HHC METRIC 8 X 25 P-1.25	2	
13	EM923343	WASHER, LOCK 5/16	2	
14	34505	SEPARATOR, WATER - FUEL	1	
15		BATTERY, 12 VOLT .....	1	..... SEE NOTE

NOTE:  
 BATTERY DIMENSIONS ARE 6-3/4" (WIDTH) X 8-3/8" (HEIGHT) X 13" (LENGTH)  
 CAPACITY 650 AMPS  
 RESERVE CAPACITY 160 MIN

# MQ600TD80 — HYDRAULIC BRAKE LINE ASSY.

HYDRAULIC BRAKE LINE ASSY.

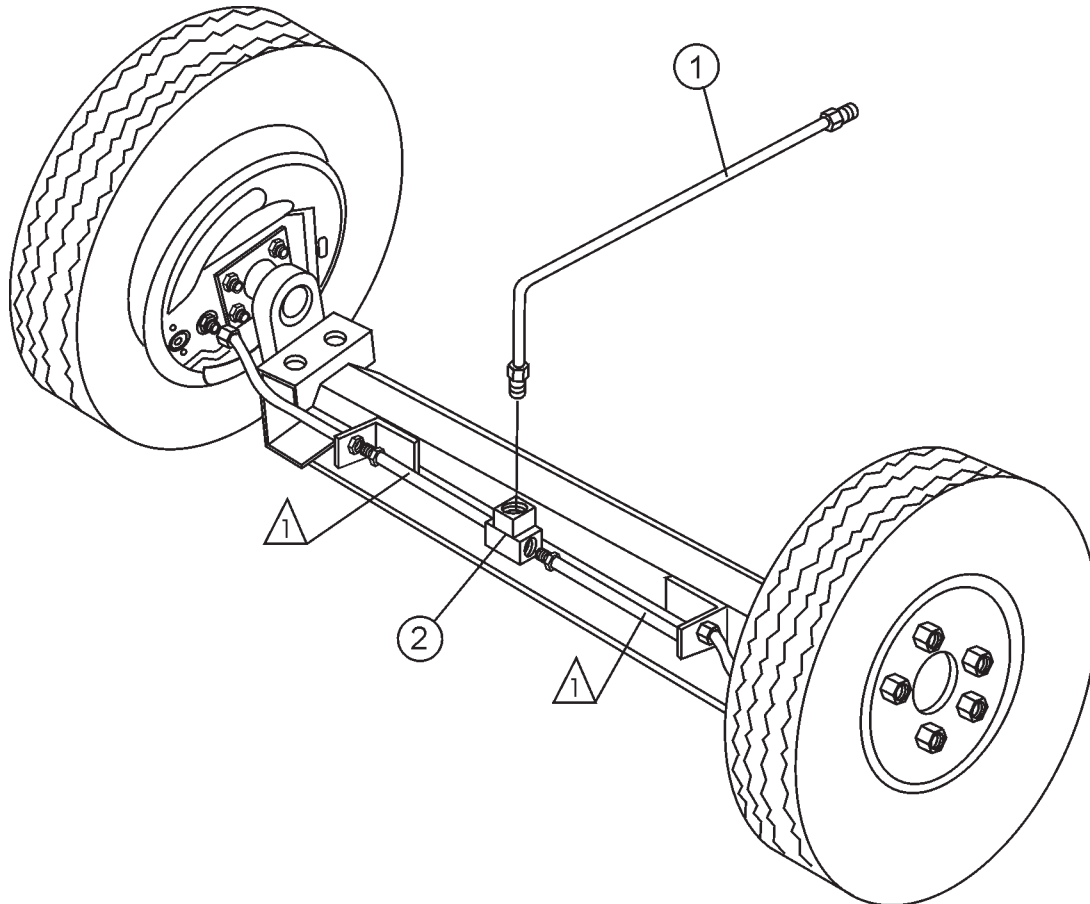

NOTES:  
△ 1 HYDRAULIC BRAKE LINE AND FITTINGS ARE INCLUDED WITH ITEM 2.

## MQ600TD80 — HYDRAULIC BRAKE LINE ASSY.

HYDRAULIC BRAKE LINE ASSY.

<u>NO.</u>	<u>PART NO.</u>	<u>PART NAME</u>	<u>QTY.</u>	<u>REMARKS</u>
1	34565	HYDRAULIC BRAKE LINE (SURGE)	1	
2	34566	KIT, TORSION LINES	1	

# MQ600TD80 — CONTROL BOX ASSY. (DEUTZ F4L913 ENGINE)

CONTROL BOX ASSY. (DEUTZ FL913 ENGINE)

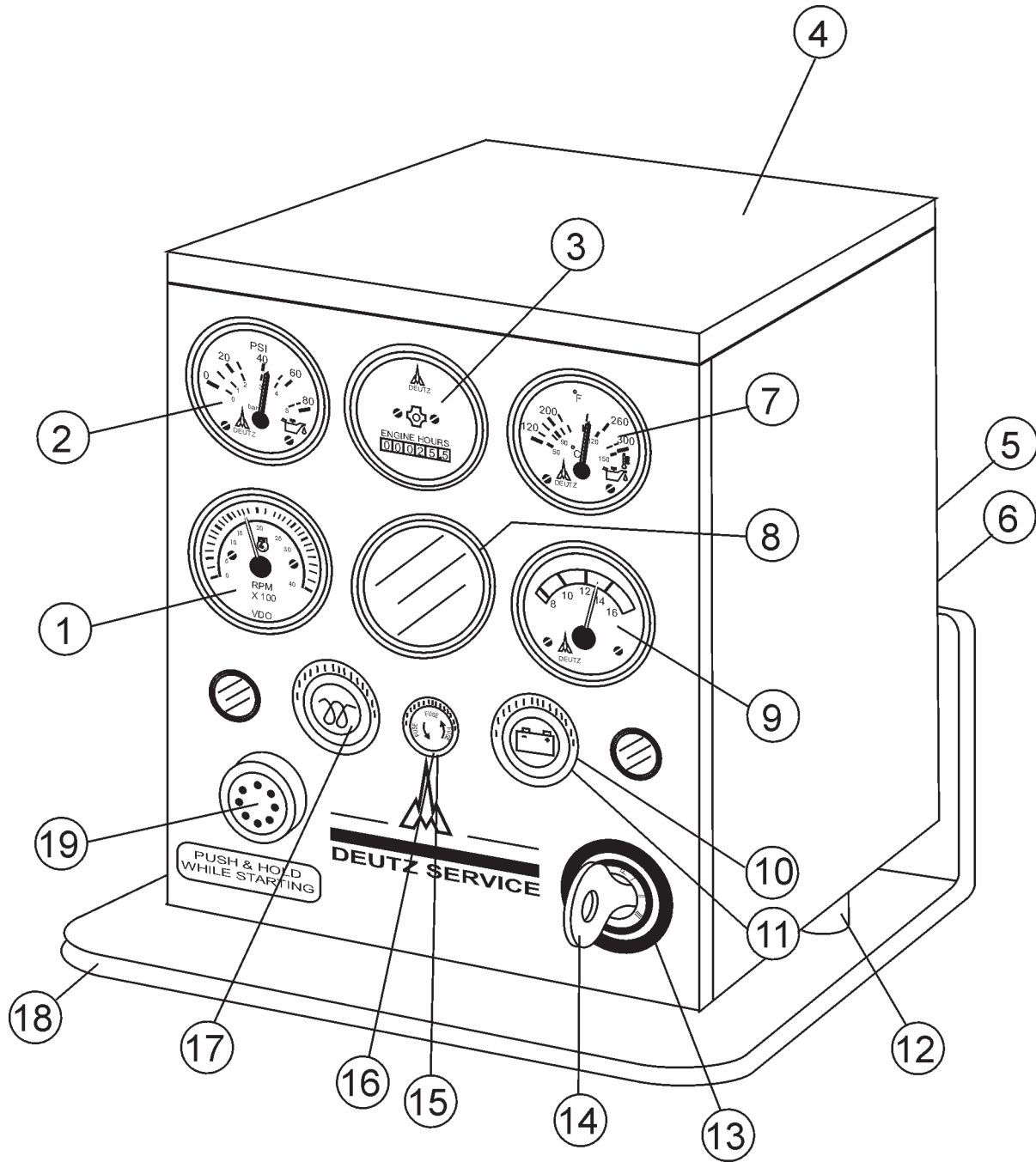

## MQ600TD80 — CONTROL BOX ASSY. (DEUTZ F4L913 ENGINE)

### CONTROL BOX ASSY. (DEUTZ FL913 ENGINE)

<u>NO.</u>	<u>PART NO.</u>	<u>PART NAME</u>	<u>QTY.</u>	<u>REMARKS</u>
1*	0302704	TACHOMETER GAUGE	1	
2*	0302700	OIL PRESSURE GAUGE	1	
3*	0302702	HOUR METER	1	
4	9990201	CONTROL BOX ASSY. (COMPLETE) .....	1	INCLUDES ITEMS W/*
5*	0302720	RECEPTACLE WHITE	1	
6*	0302721	RECEPTACLE YELLOW	1	
7*	0302701	TEMPERATURE GAUGE	1	
8*	0302705	BLIND COVER (LARGE)	1	
9*	0302703	AMPMETER	1	
10*	0302710	BATTERY CHARGE LAMP	1	
11*	0302711	12 VOLT 2 WATT BULB	1	
12*	0302729	ISOLATION SHOCKS 5/16	3	
13*	0302735	IGNITION SWITCH	1	
14*	0302736	IGNITION SWITCH KEY	1	
15*	0302708	FUSE HOLDER	1	
16*	0302709	FUSE, 15 AMP	1	
17*	0302707	PREHEAT LIGHT HOLDER .....	1	FUNCTION NOT USED
18*	0303053	CONTROL PANEL MOUNTING BRACKET	1	
19*	0302712	OIL SHUT-DOWN BYPASS SWITCH .....	1	INCLUDES RUBBER BOOT

# MQ600TD80 — CONTROL BOX ASSY. (DEUTZ F4L914 ENGINE)

CONTROL BOX ASSY. (DEUTZ FL914 ENGINE)

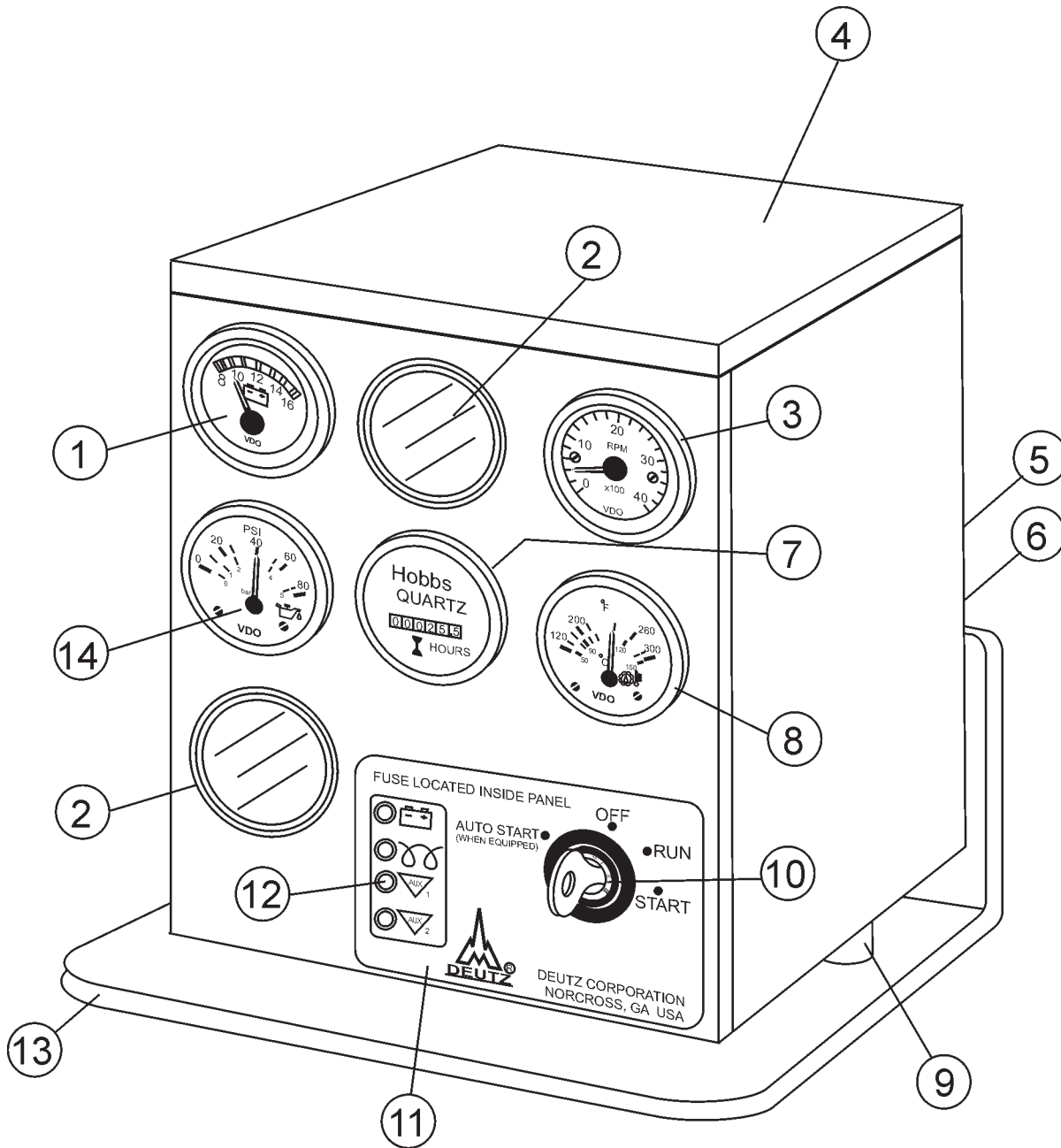

## MQ600TD80 — CONTROL BOX ASSY. (DEUTZ F4L914 ENGINE)

### CONTROL BOX ASSY. (DEUTZ FL914 ENGINE)

<u>NO.</u>	<u>PART NO.</u>	<u>PART NAME</u>	<u>QTY.</u>	<u>REMARKS</u>
1*	550-4012-01	GAUGE, VOLTMETER 12V	1	
2*	550-0002-00	BLIND COVER, BLACK 2-1/16"	2	
3*	550-1000-01	GAUGE, TACHOMETER 12V 4000 RPM	1	
4	999-0501-00	CONTROL BOX ASSY. (COMPLETE) .....	1	INCLUDES ITEMS W/*
5*	043-1008-02	RECEPTACLE WHITE	1	
6*	043-1008-01	RECEPTACLE YELLOW	1	
7*	550-0000-03	GAUGE, HOURMETER, 12-60VDC	1	
8*	550-6300-01	GAUGE, TEMP. OIL 300 12V	1	
9*	180-0516-00	ISOLATION SHOCKS 5/16-18 STUD	3	
10*	500-0010-00	IGNITION SWITCH IP63 W/KEYS	1	
11*	610-1039-06	OVERLAY 4 LED W/DEUTZ	1	
12*	070-0010-00	LENS, LED RED	4	
13*	115-0810-00	CONTROL PANEL MOUNTING BRACKET	1	
14*	550-3080-01	GAUGE OIL 80 PSI 12VDC	1	

# MQ600TD80 — DOCUMENTATION BOX ASSY.

DOCUMENTATION BOX ASSY.

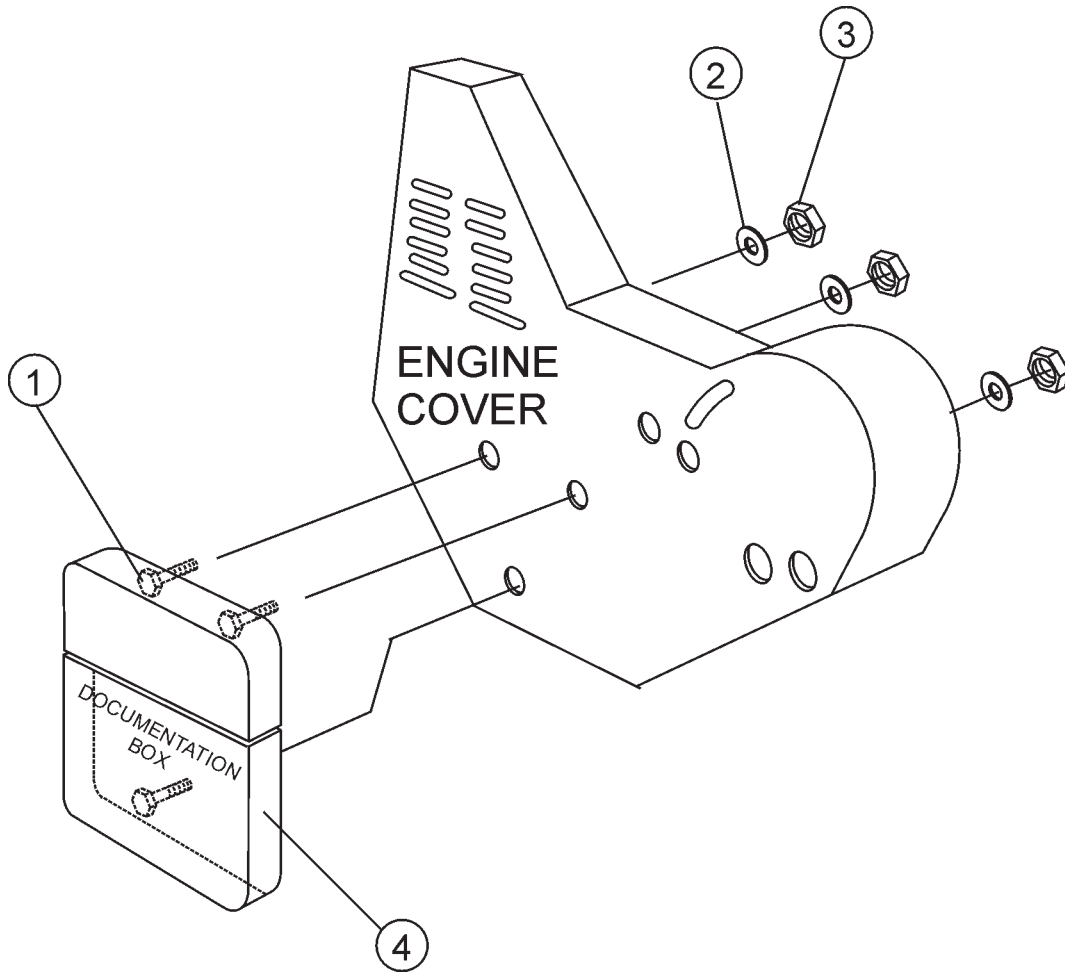

# MQ600TD80 — DOCUMENTATION BOX ASSY.

DOCUMENTATION BOX ASSY.

<u>NO.</u>	<u>PART NO.</u>	<u>PART NAME</u>	<u>QTY.</u>	<u>REMARKS</u>
1	EM963003	SCREW, HHC 1/4-20 X 3/4	3	
2	EM923057	WASHER, FLAT 1/4	3	
3	EM969079	NUT, NYLOC 1/4-20	3	
4	29057	DOCUMENTATION BOX	1	

**PAYMENT TERMS**

Terms of payment for parts are net 30 days.

**FREIGHT POLICY**

All parts orders will be shipped collect or prepaid with the charges added to the invoice. All shipments are F.O.B. point of origin. Multiquip's responsibility ceases when a signed manifest has been obtained from the carrier, and any claim for shortage or damage must be settled between the consignee and the carrier.

**MINIMUM ORDER**

The minimum charge for orders from Multiquip is \$15.00 net. Customers will be asked for instructions regarding handling of orders not meeting this requirement.

**RETURNED GOODS POLICY**

Return shipments will be accepted and credit will be allowed, subject to the following provisions:

1. A Returned Material Authorization must be approved by Multiquip prior to shipment.
2. To obtain a Return Material Authorization, a list must be provided to Multiquip Parts Sales that defines item numbers, quantities, and descriptions of the items to be returned.
  - a. The parts numbers and descriptions must match the current parts price list.
  - b. The list must be typed or computer generated.
  - c. The list must state the reason(s) for the return.
  - d. The list must reference the sales order(s) or invoice(s) under which the items were originally purchased.
  - e. The list must include the name and phone number of the person requesting the RMA.
3. A copy of the Return Material Authorization must accompany the return shipment.
4. Freight is at the sender's expense. All parts must be returned freight prepaid to Multiquip's designated receiving point.

5. Parts must be in new and resalable condition, in the original Multiquip package (if any), and with Multiquip part numbers clearly marked.
6. The following items are not returnable:
  - a. Obsolete parts. (If an item is in the price book and shows as being replaced by another item, it is obsolete.)
  - b. Any parts with a limited shelf life (such as gaskets, seals, "O" rings, and other rubber parts) that were purchased more than six months prior to the return date.
  - c. Any line item with an extended dealer net price of less than \$5.00.
  - d. Special order items.
  - e. Electrical components.
  - f. Paint, chemicals, and lubricants.
  - g. Decals and paper products.
  - h. Items purchased in kits.
7. The sender will be notified of any material received that is not acceptable.
8. Such material will be held for five working days from notification, pending instructions. If a reply is not received within five days, the material will be returned to the sender at his expense.
9. Credit on returned parts will be issued at dealer net price at time of the original purchase, less a 15% restocking charge.
10. In cases where an item is accepted, for which the original purchase document can not be determined, the price will be based on the list price that was effective twelve months prior to the RMA date.
11. Credit issued will be applied to future purchases only.

**PRICING AND REBATES**

Prices are subject to change without prior notice. Price changes are effective on a specific date and all orders received on or after that date will be billed at the revised price. Rebates for price declines and added charges for price increases will not be made for stock on hand at the time of any price change.

Multiquip reserves the right to quote and sell direct to Government agencies, and to Original Equipment Manufacturer accounts who use our products as integral parts of their own products.

**SPECIAL EXPEDITING SERVICE**

A \$35.00 surcharge will be added to the invoice for special handling including bus shipments, insured parcel post or in cases where Multiquip must personally deliver the parts to the carrier.

**LIMITATIONS OF SELLER'S LIABILITY**

Multiquip shall not be liable hereunder for damages in excess of the purchase price of the item with respect to which damages are claimed, and in no event shall Multiquip be liable for loss of profit or good will or for any other special, consequential or incidental damages.

**LIMITATION OF WARRANTIES**

No warranties, express or implied, are made in connection with the sale of parts or trade accessories nor as to any engine not manufactured by Multiquip. Such warranties made in connection with the sale of new, complete units are made exclusively by a statement of warranty packaged with such units, and Multiquip neither assumes nor authorizes any person to assume for it any other obligation or liability whatever in connection with the sale of its products. Apart from such written statement of warranty, there are no warranties, express, implied or statutory, which extend beyond the description of the products on the face hereof.



# OPERATION AND PARTS MANUAL

## HERE'S HOW TO GET HELP

PLEASE HAVE THE MODEL AND SERIAL  
NUMBER *ON-HAND* WHEN CALLING

### UNITED STATES

#### ***Multiquip Corporate Office***

18910 Wilmington Ave.      Tel. (800) 421-1244  
Carson, CA 90746      Fax (800) 537-3927  
Contact: mq@multiquip.com

#### ***Mayco Parts***

800-306-2926      Fax: 800-672-7877  
310-537-3700      Fax: 310-637-3284

#### ***Service Department***

800-421-1244      Fax: 310-537-4259  
310-537-3700

#### ***MQ Parts Department***

800-427-1244      Fax: 800-672-7877  
310-537-3700      Fax: 310-637-3284

#### ***Warranty Department***

800-421-1244, Ext. 279      Fax: 310-537-1173  
310-537-3700, Ext. 279

#### ***Technical Assistance***

800-478-1244      Fax: 310-631-5032

### MEXICO

#### ***MQ Cipsa***

Carr. Fed. Mexico-Puebla KM 126.5      Tel: (52) 222-225-9900  
Momoxpan, Cholula, Puebla 72760 Mexico      Fax: (52) 222-285-0420  
Contact: pmastretta@cipsa.com.mx

### CANADA

#### ***Multiquip***

4110 Industriel Boul.      Tel: (450) 625-2244  
Laval, Quebec, Canada H7L 6V3      Fax: (450) 625-8664  
Contact: jmartin@multiquip.com

### UNITED KINGDOM

#### ***Multiquip (UK) Limited Head Office***

Hanover Mill, Fitzroy Street,      Tel: 0161 339 2223  
Ashton-under-Lyne,      Fax: 0161 339 3226  
Lancashire OL7 0TL  
Contact: sales@multiquip.co.uk

### BRAZIL

#### ***Multiquip***

Av. Evandro Lins e Silva, 840 - grupo 505      Tel: 011-55-21-3433-9055  
Barra de Tijuca - Rio de Janeiro      Fax: 011-55-21-3433-9055  
Contact: cnavarro@multiquip.com.br, srentes@multiquip.com.br

© COPYRIGHT 2006, MULTIQUIP INC.

Multiquip Inc, the MQ logo and the MQ logo are registered trademarks of Multiquip Inc. and may not be used, reproduced, or altered without written permission. All other trademarks are the property of their respective owners and used with permission.

This manual MUST accompany the equipment at all times. This manual is considered a permanent part of the equipment and should remain with the unit if resold.

The information and specifications included in this publication were in effect at the time of approval for printing. Illustrations are based on the *MQ Model MQ600TD80 Diesel Powered Trash Pump*. Illustrations, descriptions, references and technical data contained in this manual are for guidance only and may not be considered as binding. Multiquip Inc. reserves the right to discontinue or change specifications, design or the information published in this publication at any time without notice and without incurring any obligations.

Your Local Dealer is:

