

# OPERATION AND PARTS MANUAL



# *Mikasa*

## Vibration Roller Model MRH-800GS (Gasoline)

© COPYRIGHT 2003, MULTIQUIP INC.

Revision # 4 (08/09/05)



**MULTIQUIP INC.**

18910 WILMINGTON AVE.  
CARSON, CALIFORNIA 90746  
310-537-3700  
800-421-1244  
FAX: 310-537-3927

**E-mail:** [mq@multiquip.com](mailto:mq@multiquip.com) • **www:** [www.multiquip.com](http://www.multiquip.com)

Atlanta • Boise • Dallas • Houston • Newark  
Montreal, Canada • Manchester, UK  
Rio De Janeiro, Brazil • Guadalajara, Mexico

**PARTS DEPARTMENT:**

800-427-1244  
FAX: 800-672-7877  
**SERVICE DEPARTMENT/TECHNICAL ASSISTANCE:**  
800-478-1244  
FAX: 310-631-5032

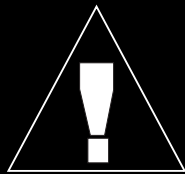

# WARNING

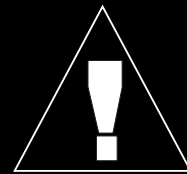

## **CALIFORNIA — Proposition 65 Warning**

Engine exhaust and some of its constituents are known to the State of California to cause cancer, birth defects and other reproductive harm.

## **HERE'S HOW TO GET HELP**

*PLEASE HAVE THE MODEL AND SERIAL  
NUMBER ON-HAND WHEN CALLING*

### ***PARTS DEPARTMENT***

*800-427-1244 or 310-537-3700*

*FAX: 800-672-7877 or 310-637-3284*

### ***SERVICE DEPARTMENT***

*800-421-1244*

*FAX: 310- 537-4259*

### ***TECHNICAL ASSISTANCE***

*800-478-1244*

*FAX: 310- 631-5032*

### ***WARRANTY DEPARTMENT***

*888-661-4279, or 310-661-4279*

*FAX: 310- 537-1173*

Proposition 65 Warning ..... 2  
 Here's How To Get Help ..... 3  
 Table Of Contents ..... 4  
 Parts Ordering Procedures ..... 5

## MIKASA MRH-800GS-VIBRATION ROLLER

Safety Message Alert Symbols ..... 6-7  
 Rules for Safe Operation ..... 8-9  
 Operation and Safety Decals ..... 10-11  
 Roller Specifications ..... 12  
 Engine Specifications ..... 13  
 Dimensions ..... 14  
 Features ..... 15  
 Vibration roller Components ..... 16-17  
 Handle Bar/Lever Components ..... 18-19  
 Engine Components ..... 20  
 Inspection ..... 22-23  
 Operation ..... 24-27  
 Maintenance ..... 28-31  
 Roller Troubleshooting ..... 34-35  
 Engine Troubleshooting ..... 36-37

## PARTS ILLUSTRATIONS

Explanation Of Code In Remarks Column ..... 38  
 Suggested Spare Parts ..... 39  
 Decal Placement ..... 40-41  
 Axle Assembly ..... 42-43  
 Base Assembly ..... 44-45  
 Front Guard Assembly ..... 46-47  
 Side Cover Assembly ..... 48-49  
 Water Tank Assembly ..... 50-51  
 Hydraulic System Assembly ..... 52-55  
 Hydraulic Oil Tank Assembly ..... 56-57  
 Engine Assembly Assembly ..... 58-61  
 Electric Device Assembly ..... 62-63  
 Clutch (Vibration) Assembly ..... 64-65  
 Vibrator Assembly ..... 66-67  
 Upper Control Arm Assembly ..... 68-71  
 Lower Control Arm Assyembly ..... 72-73

## HONDA GX390K1SM32 GASOLINE ENGINE

Cylinder Head Assembly ..... 74-75  
 Cylinder Barrel Assembly ..... 76-77  
 Crankcase Cover Assembly ..... 78-79  
 Crankshaft Assembly ..... 80-81  
 Piston Assembly ..... 82-83  
 Camshaft Assembly ..... 84-85  
 Recoil Starter Assembly ..... 86-87  
 Fan Cover Assembly ..... 88-89  
 Carburetor Assembly ..... 90-91  
 Air Cleaner Assembly ..... 92-93  
 Muffler Assembly ..... 94-95  
 Fuel Tank Assembly ..... 96-97  
 Fly Wheel Assembly ..... 98-99  
 Ignition Coil Assembly ..... 100-101  
 Starter Motor Assembly ..... 102-103  
 Control Assembly ..... 104-105  
 Control Box Assembly ..... 106-107  
 Label Assembly ..... 108-109  
 Terms and Conditions Of Sale — Parts ..... 110

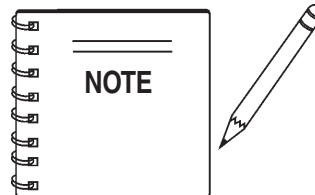

*Specification and part number are subject to change without notice.*

# PARTS ORDERING PROCEDURES

## When ordering parts, please supply the following information:

- Dealer account number
- Dealer name and address
- Shipping address (if different than billing address)
- Return fax number
- Applicable model number
- Quantity, part number and description of each part
- Specify preferred method of shipment:
  - ✓ FedEx or UPS Ground
  - ✓ FedEx or UPS Second Day or Third Day
  - ✓ FedEx or UPS Next Day
  - ✓ Federal Express Priority One
  - ✓ DHL
  - ✓ Truck

*Note: Unless otherwise indicated by customer, all orders are treated as "Standard Orders", and will ship within 24 hours. We will make every effort to ship "Air Shipments" the same day that the order is received, if prior to 2PM west coast time. "Stock Orders" must be so noted on fax or web forms.*



## Here's how to get help...

*Please have the model and serial number on hand when calling.*

### Parts Department

800-427-1244 Fax: 800-672-7877  
310-537-3700 Fax: 310-637-3284

### Mayco Parts

800-306-2926 Fax: 800-672-7877  
310-537-3700 Fax: 310-637-3284

### Service Department

800-478-1244 Fax: 310-537-4259  
310-537-3700

### MQ Power Service Department

800-835-2551 Fax: 310-638-8046  
310-537-3700

### Warranty Department

800-421-1244, Ext. 279 Fax: 310-537-1173  
310-537-3700, Ext. 279

### Multiquip's Main Phone Numbers

800-421-1244 Fax: 310-537-3927  
310-537-3700

## Place Your Parts Order Via Web or Fax For Even More Savings!

### Extra Discounts!

All parts orders which include complete part numbers and are received by our automated web parts order system, or by fax qualify for the following extra discounts:

Ordered via	Standard orders	Stock orders (\$750 list and above)
Fax	3%	10%
Web	5%	10%

### Special freight allowances when you order 10 or more line items via Web or Fax! \*\*

FedEx Ground Service **at no charge for freight**

*No other allowances on freight shipped by any other carrier.*

NOTE: DISCOUNTS ARE SUBJECT TO CHANGE



**MULTIQUIP INC.**  
18910 WILMINGTON AVENUE  
POST OFFICE BOX 6254  
CARSON, CALIFORNIA 90749  
310-537-3700 • 800-421-1244  
FAX: 310-537-3927  
E-MAIL: mq@multiquip.com  
WWW: multiquip.com

**Direct TOLL-FREE access  
to our Parts Department:**

Toll-free nationwide — 800-427-1244

# MRH-800GS — SAFETY MESSAGE ALERT SYMBOLS

## FOR YOUR SAFETY AND THE SAFETY OF OTHERS!

Safety precautions should be followed at all times when operating this equipment. Failure to read and understand the Safety Messages and Operating Instructions could result in injury to yourself and others.

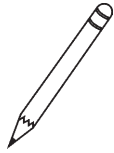
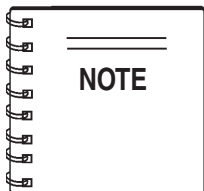

This Owner's Manual has been developed to provide complete instructions for the safe and efficient operation of the Multiquip Model MRH-800GS Vibration Roller. Refer to the engine manufacturer's instructions for data relative to its safe operation.

Before using this vibration roller, ensure that the operating individual has read and understands all instructions in this manual.

## SAFETY MESSAGE ALERT SYMBOLS

The three (3) Safety Messages shown below will inform you about potential hazards that could injure you or others. The Safety Messages specifically address the level of exposure to the operator, and are preceded by one of three words: **DANGER**, **WARNING**, or **CAUTION**.



**DANGER:** You **WILL** be **KILLED** or **SERIOUSLY** injured if you do not follow directions.



**WARNING:** You **CAN** be **KILLED** or **SERIOUSLY** injured if you do not follow directions.



**CAUTION:** You **CAN** be injured if you do not follow directions.

Potential hazards associated with this vibration roller operation will be referenced with Hazard Symbols which appear throughout this manual, and will be referenced in conjunction with Safety Message Alert Symbols.

## HAZARD SYMBOLS



### Lethal Exhaust Gases



Engine exhaust gases contain poisonous carbon monoxide. This gas is colorless and odorless, and can cause death if inhaled. **NEVER** operate this equipment in a confined area or enclosed structure that does not provide ample free flow air.



### Explosive Fuel



**GASOLINE** is extremely flammable, and its vapors can cause an explosion if ignited. **DO NOT** start the engine near spilled fuel or combustible fluids. **DO NOT** fill the fuel tank while the engine is running or hot. **DO NOT** overfill tank, since spilled fuel could ignite if it comes into contact with hot engine parts or sparks from the ignition system. Store fuel in approved containers, in well-ventilated areas and away from sparks and flames. **NEVER** use fuel as a cleaning agent.



### Burn Hazards



Engine components can generate extreme heat. To prevent burns, **DO NOT** touch these areas while the engine is running or immediately after operations. Never operate the engine with heat shields or heat guards removed.



### Rotating Parts



**NEVER** operate equipment with covers, or guards removed. Keep fingers, hands, hair and clothing away from all moving parts to prevent injury.

# MRH-800GS — SAFETY MESSAGE ALERT SYMBOLS

## Accidental Starting



OFF

**ALWAYS** place the engine ON/OFF switch in the **OFF** position, when the vibration roller is not in use.

## Respiratory Hazard



**ALWAYS** wear approved respiratory protection.

## Sight and Hearing hazard



**ALWAYS** wear approved eye and hearing protection.

## Equipment Damage Messages

Other important messages are provided throughout this manual to help prevent damage to your vibration roller, other property, or the surrounding environment.

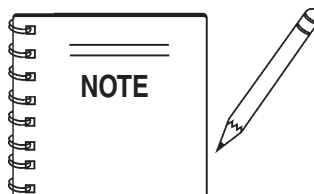

This vibration roller, other property, or the surrounding environment could be damaged if you do not follow instructions.

# MRH-800GS — RULES FOR SAFE OPERATION

## CAUTION:



Failure to follow instructions in this manual may lead to serious injury or even death! This equipment is to be operated by trained and qualified personnel only! This equipment is for industrial use only.

The following safety guidelines should always be used when operating the MIKASA MRH-800GS Vibration Roller:

### GENERAL SAFETY

- **DO NOT** operate or service this equipment before reading this entire manual.



- This equipment should not be operated by persons under 18 years of age.



- **NEVER** operate this equipment without proper protective clothing, shatterproof glasses, steel-toed boots and other protective devices required by the job. **ALWAYS** wear slip resistant safety shoes or boots.



- **NEVER** operate this equipment when not feeling well due to fatigue, illness or taking medicine.



- **NEVER** operate this equipment under the influence of drugs or alcohol.

- **NEVER** use accessories or attachments, which are not recommended by Multiquip for this equipment. Damage to the equipment and/or injury to user may result.

- Manufacturer does not assume responsibility for any accident due to equipment modifications.

- Whenever necessary, replace nameplate, operation and safety decals when they become difficult to read.

- **ALWAYS** wear proper respiratory (mask), hearing and eye protection equipment when operating the vibration roller.

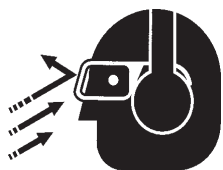

- **NEVER** touch the hot exhaust manifold, muffler or cylinder. Allow these parts to cool before servicing engine or vibration roller.



- **High Temperatures** – Allow the engine to cool before adding fuel or performing service and maintenance functions. Contact with *hot* components can cause serious burns.

- The engine of this vibration roller requires an adequate free flow of cooling air. **NEVER** operate the vibration roller in any enclosed or narrow area where free flow of the air is restricted. If the air flow is restricted it will cause serious damage to the vibration roller or engine and may cause injury to people and property. Remember the vibration roller's engine gives off **DEADLY** gases.

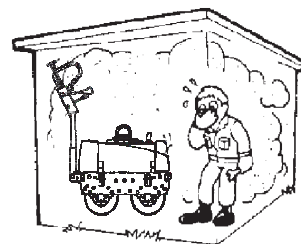

- **ALWAYS** refuel in a well-ventilated area, away from sparks and open flames.

- **ALWAYS** use extreme caution when working with **flammable** liquids. When refueling, **stop the engine** and allow it to cool. **DO NOT smoke** around or near the machine. Fire or explosion could result from fuel vapors, or if fuel is spilled on a hot engine.

- **NEVER** operate the vibration roller in an explosive atmosphere or near combustible materials. An explosion or fire could result causing severe *bodily harm or even death*.

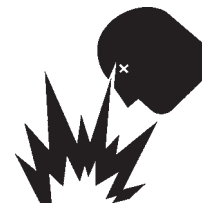

- Topping-off to filler port is dangerous, as it tends to spill fuel.

- **ALWAYS** store the vibration roller in a clean, dry location out of the reach of children.

- **NEVER** run engine without air cleaner. Severe engine damage may occur.

- **NEVER** leave the vibration roller unattended, turn off engine.

- **CAUTION** must always be observed while servicing this vibration roller. Rotating parts can cause injury if contacted.

- **DO NOT** leave vibration roller with engine running. Use chock blocks if parking vibration roller on a grade.

# MRH-800GS — RULES FOR SAFE OPERATION

- **ALWAYS** use extreme care when operating near obstructions, on slippery surfaces, grades and side slopes.
- When reversing, particularly on the edges and banks of ditches, as well as in front of obstacles, the operator must stay in a standing position at a safe distance from the machine.
- When operating near any house/building or pipelines, always check the effect of machine vibration. Stop the work if necessary.
- Unauthorized equipment modifications will void all warranties.
- Refer to the *Engine Owner's Manual* for engine technical questions or information.
- **DO NOT** operate the vibration roller with the front or rear cover open.
- Replace any worn or damaged vibration roller components immediately.
- **ALWAYS** turn the engine **OFF** before performing maintenance.
- **ALWAYS** make sure vibration roller is correctly secured to the trailer. Check all supports attaching the vibration roller to the trailer and make sure they are tight.
- **ALWAYS** keep the machine away from workers and obstacles. Also keep the immediate area free of bystanders.
- **ALWAYS** check the machine for loosened threads or bolts before starting.
- **ALWAYS** read, understand, and follow procedures in Operator's Manual before attempting to operate equipment.
- **ALWAYS** be sure the operator is familiar with proper safety precautions and operations techniques before using vibration roller.
- A copy of this manual shall accompany the vibration roller at all times.
- **DO NOT** use worn out hoses or couplings; inspect daily.
- **High Temperatures** – Always stop engine and allow the engine to cool before adding fuel, oil or performing service and maintenance functions. Contact with *hot* components can cause serious burns.
- **NEVER** disconnect any "**emergency or safety devices**". These devices are intended for operator safety. Disconnection of these devices can cause severe injury, bodily harm or even death! Disconnection of any of these devices will void all warranties.

## Emergencies

- **ALWAYS** know the location of the nearest **fire extinguisher** and **first aid kit**. Know the location of the nearest telephone. Also know the phone numbers of the nearest **ambulance, doctor** and **fire department**. This information will be invaluable in case of an emergency.

## Maintenance Safety

- **NEVER** lubricate components or attempt service on a running machine.
- **ALWAYS** allow the machine a proper amount of time to cool before servicing.
- Keep the machinery in proper running condition.
- Fix damage to the machine immediately and always replace broken parts.
- Dispose of hazardous waste properly. Examples of potentially hazardous waste are used motor oil, fuel and fuel filters.
- **DO NOT** use food or plastic containers to dispose of hazardous waste.
- **DO NOT** pour waste, oil or fuel directly onto the ground, down a drain or into any water source.

## Lifting

- The vibration roller has an operating weight of approximately 1530 lbs. (694 kg). Use lifting equipment capable of lifting this weight.
- Make sure the engine is off before lifting the machine.
- Use reliable cable in lifting the machine.
- Lift upright with sufficient bearing capacity to prevent machine from tilting or slipping.
- When lifting, keep the machine away from workers and animals.

# MRH-800GS — OPERATION AND SAFETY DECALS

Figure 1 displays the operation and safety decals as they appear on the vibration roller. Should any of these decals become damaged or unreadable, contact the Multiquip Parts Department for a replacement set.



P/N: 920205690

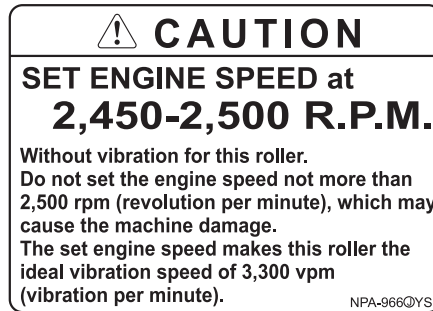

P/N: 920209660



P/N: 920206280

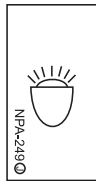

P/N: 920102490



P/N: 920101480



P/N: 920108070



P/N: DCL 210

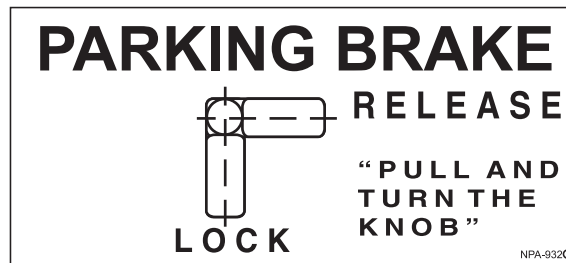

P/N: 920208070



P/N: 920100120

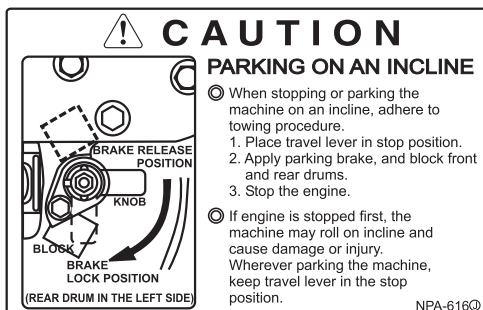

P/N: 920206160

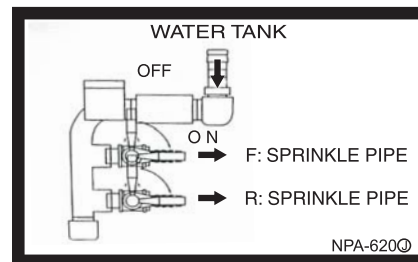

P/N: 920206200

Figure 1. Operation and Safety Decals

# MRH-800GS — OPERATION AND SAFETY DECALS



P/N: 920203330



P/N: 920201910

# Mikasa

P/N: 920101510

# MRH800GS

P/N: 920207610



P/N: 920200320

IN COLD SEASON FOR HOUSING, DRAIN FROM WATER TANK AND HOSES TO PREVENT FREEZING

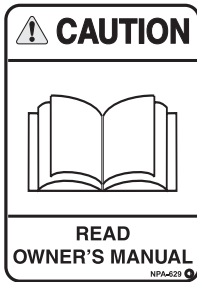

P/N: 920206290

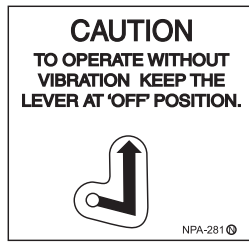

P/N: 920202810



P/N: 920104280



P/N: 920200470

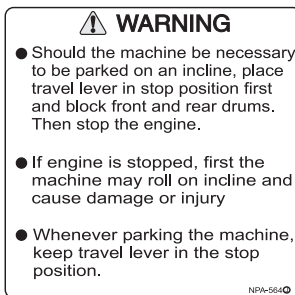

P/N: NPA-564



P/N: 920105170

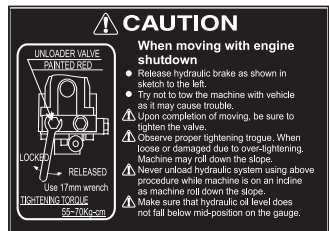

P/N: 920202860



P/N: 920201450



P/N: 920202920

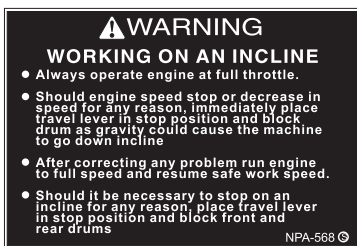

P/N: 920205680

Figure 1. Operation and Safety Decals (Continued)

## TABLE 1. ROLLER SPECIFICATIONS

Dimensions	105 x 27.2 x 41.7 in (2670 x 692 x 1060 mm)
Drum Diameter	16 in. (406 mm)
Drum Width	25.6 in. (650 mm)
Curb Clearance	9.6 in. (243 mm)
Side Overhang	.83 in.(21 mm)
Operating Weight (with water)	1530 lbs. (694 kg)
Vibration Frequency	3,300 vpm
Centrifugal Force	23.5/2,400 kn/kgf
Drive System	Hydraulic Motor
Vibration System	Frame
Vibration Method	Belt Drive
Vibrator Shaft	Twin
Gradeability	20 degrees
Working Speed	0 - 3 mph (0 - 4.8 kph)
Fuel Tank Capacity	1.88 gallons (7.1 liters)
Lubricating Oil	6.6 gallons (25 liters)
Water Tank Capacity	10.57 gallons (40 liters)
Engine Model	Honda GX390SM32
Starting System	Electric/Recoil Start

# MRH-800GS — ENGINE SPECIFICATIONS

**TABLE 2. ENGINE SPECIFICATIONS**

<b>Engine</b>	<b>Model</b>	<b>HONDA GX390SK1M32</b>
	Type	Air-cooled 4 stroke, Single Cylinder, OHV, Horizontal Shaft Gasoline Engine
	Bore X Stroke	2.90 in. X 2.30 in. (73 mm x 58 mm.)
	Displacement	23.70 cu-in (389 cm <sup>3</sup> )
	Max Output	13.0 H.P./3600 R.P.M.
	Fuel Tank Capacity	1.72 gallons (6.5 liters)
	Fuel	Unleaded Automobile Gasoline
	Lube Oil Capacity	1.16 quarts (1.1 liters)
	Oil Alert System	Yes
	Speed Control Method	Centrifugal Fly-weight Type
	Starting Method	Electric/Recoil Start
<b>Dimension (L x W x H)</b>	15.0 x 17.7 X 17.4 in. (380 X 450 X 443 mm.)	
<b>Dry Net Weight</b>	68.4 lbs (31 Kg.)	

# MRH-800GS — VIBRATION ROLLER DIMENSIONS

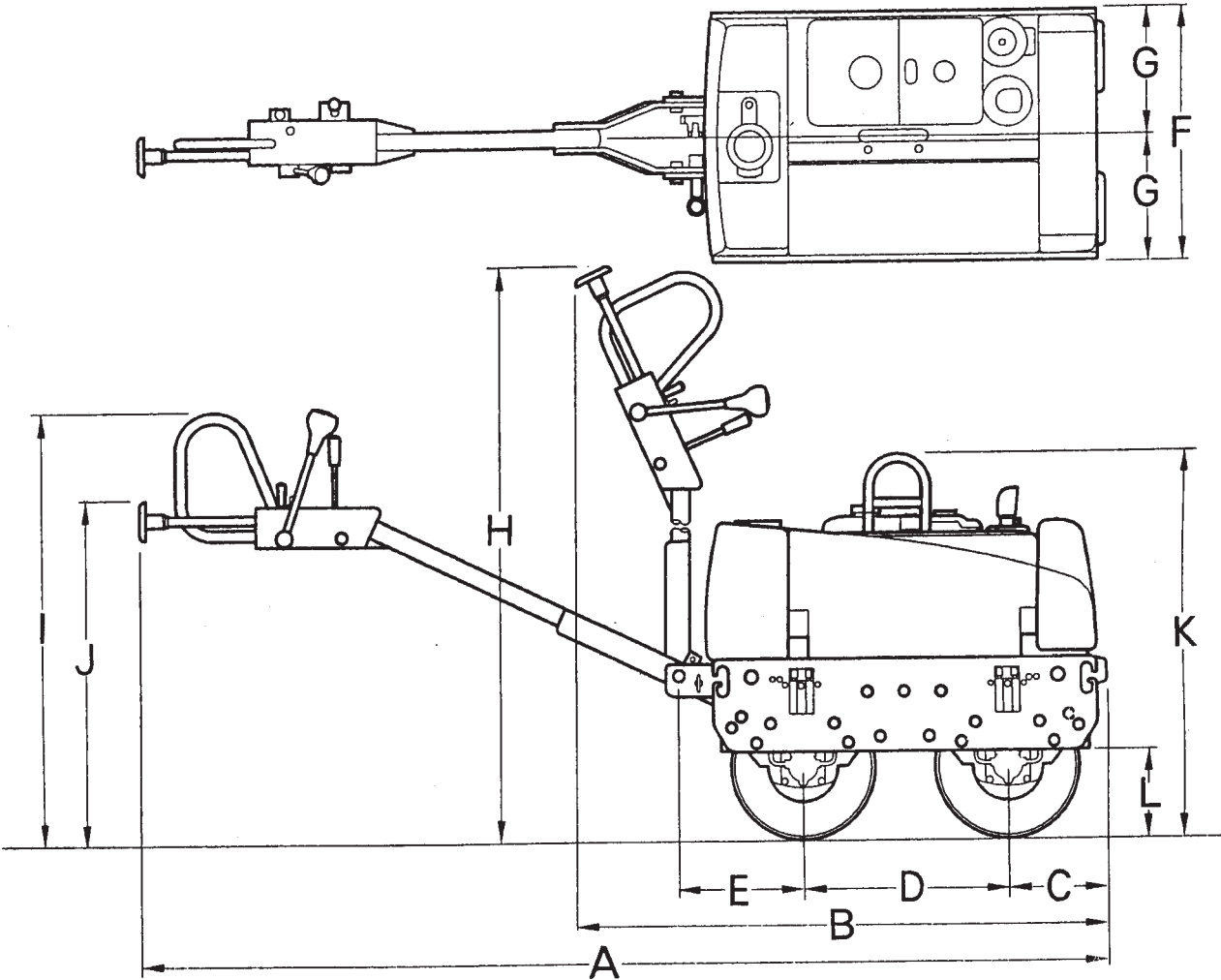

TABLE 3. DIMENSIONS			
LENGTH	A	105 in.	2670 mm.
	B	57 in.	1445 mm.
	C	10 in.	255 mm.
	D	22.8 in.	580 mm.
	E	13.8 in.	350 mm.
WIDTH	F	27.2 in.	692 mm.
	G	13.6 in.	346 mm.
HEIGHT	H	78.3 in.	1990 mm.
	I	46.5 in.	1180 mm.
	J	37.4 in.	950 mm.
	K	41.7 in.	1060 mm.
	L	9.6 in.	245 mm.

Figure 2. MRH-800GS Vibration Roller Dimensions

The Mikasa Model MRH-800GS is a powerful compacting tool capable of applying a tremendous force in consecutive impacts to a soil surface. Its applications include soil compacting for backfilling for gas pipelines, water pipelines and cable installation work.

The impact force of the MRH-800GS levels and uniformly compacts voids between soil particles to increase dry density.

Features include:

- Hydraulic transmission to allow speed change without gear shifting.
- Deadman device which when pressed or hit will cause the travel lever to return to neutral position bringing the machine to a stop.
- A horn to warn of machine's approach.
- Low engine oil level shut down
- Non-corrosive water tank for the sprinkler system with a capacity of more than 10 gallons.
- Lifting hook to transport machine.
- Front bumper and working light.
- Narrow profile with less than one inch wall clearance. Narrower width allows access to tighter areas. No exposed hydraulic hoses.
- Oil bath lubricated bearings and external vibration for less servicing and more dependability.
- Front and rear drum scrapers.
- Drum sprinkler system controls located near the operator.
- Easy access to hydraulic components and hydraulic filter.

# MRH-800GS — VIBRATION ROLLER COMPONENTS

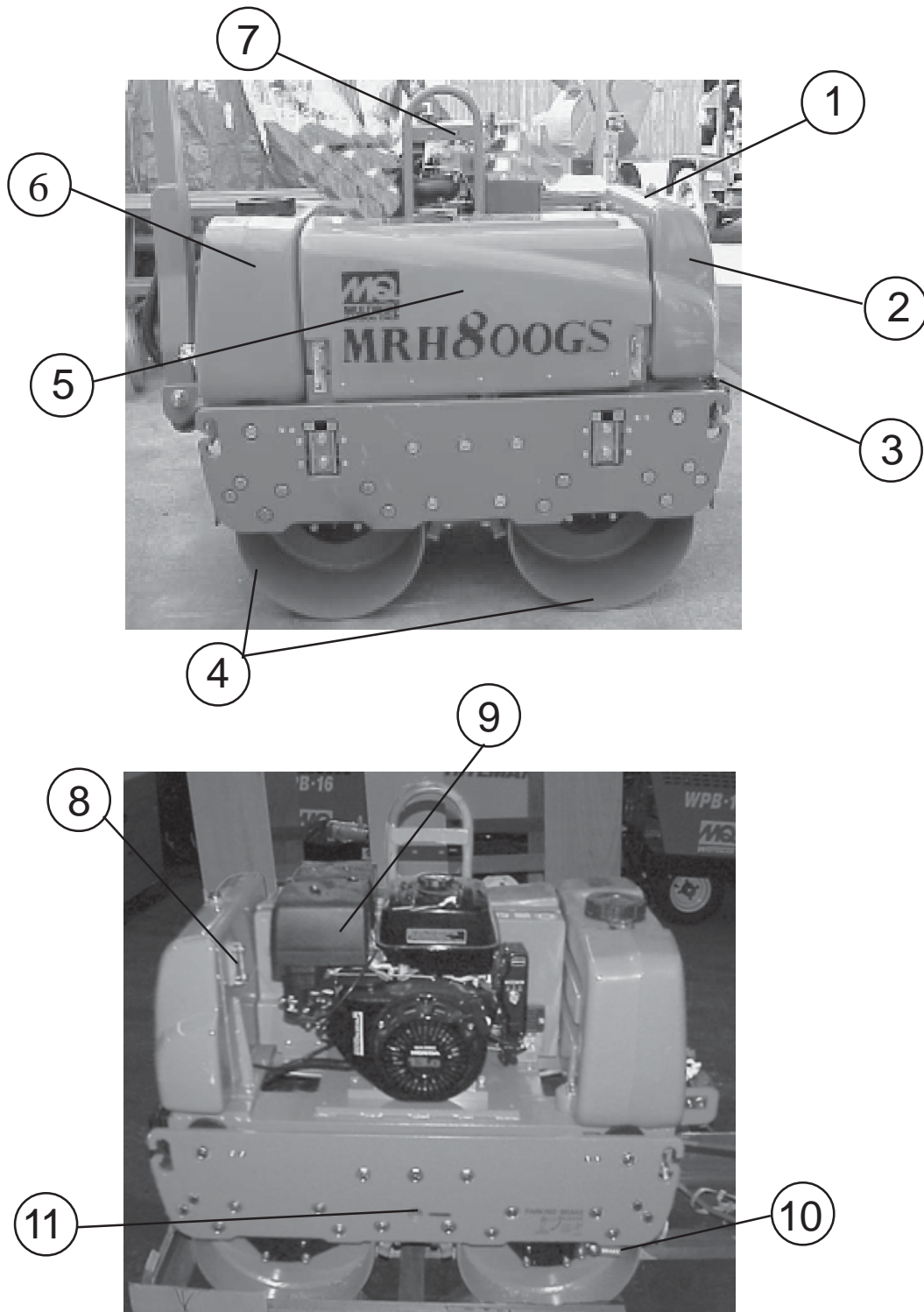

Figure 3. MRH-800GS Vibration Roller Components

## MRH-800GS — VIBRATION ROLLER COMPONENTS

Figure 3 illustrates the location of the major components for the MRH-800GS Vibration Roller. The function of each component is described below:

1. **Fuel Tank/Cap** – Fill with diesel fuel. Fuel tank holds approximately 2 gallons (7.5 liters). **DO NOT** top off fuel. Wipe up any spilled fuel immediately.
2. **Hydraulic Oil Tank** - Fill with proper grade of hydraulic oil. Check fluid level using the hydraulic oil gauge.
3. **Front Headlights** – Activate using switch on control handle. Use to illuminate ground during nighttime or low light operating conditions.
4. **Vibration Rollers** – 25-inch wide steel drums that provide compaction force in the compaction and patching of asphalt type surfaces.
6. **Center Cover** – When opened and supported by strut, provides access to *oil pump and filter, battery, V-belt, and clutch box*.
6. **Water Tank**– Holds 10.57 gallons (40 liters) for the sprinkler system.
7. **Lifting Hook** – Used to lift the machine with crane or other lifting device.
8. **Hydraulic Oil Gauge** – Indicates the hydraulic oil level.
9. **Engine** – This machine uses the Honda GX390K1SM32 gasoline engine. Refer to page 20 for more information.
10. **Parking Brake** – Makes sure machine will not accidentally move when parked or not in use.
11. **Vibrator Oil Level Plug** – Remove to check vibrator oil level.

# MRH-800GS — HANDLE BAR/LEVER COMPONENTS

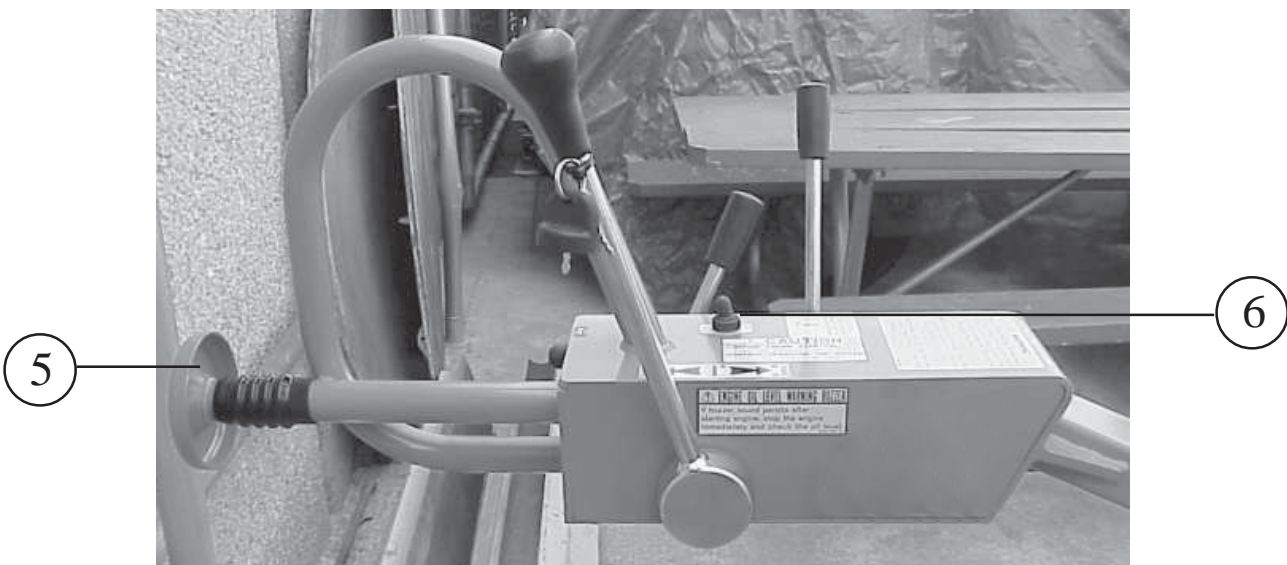
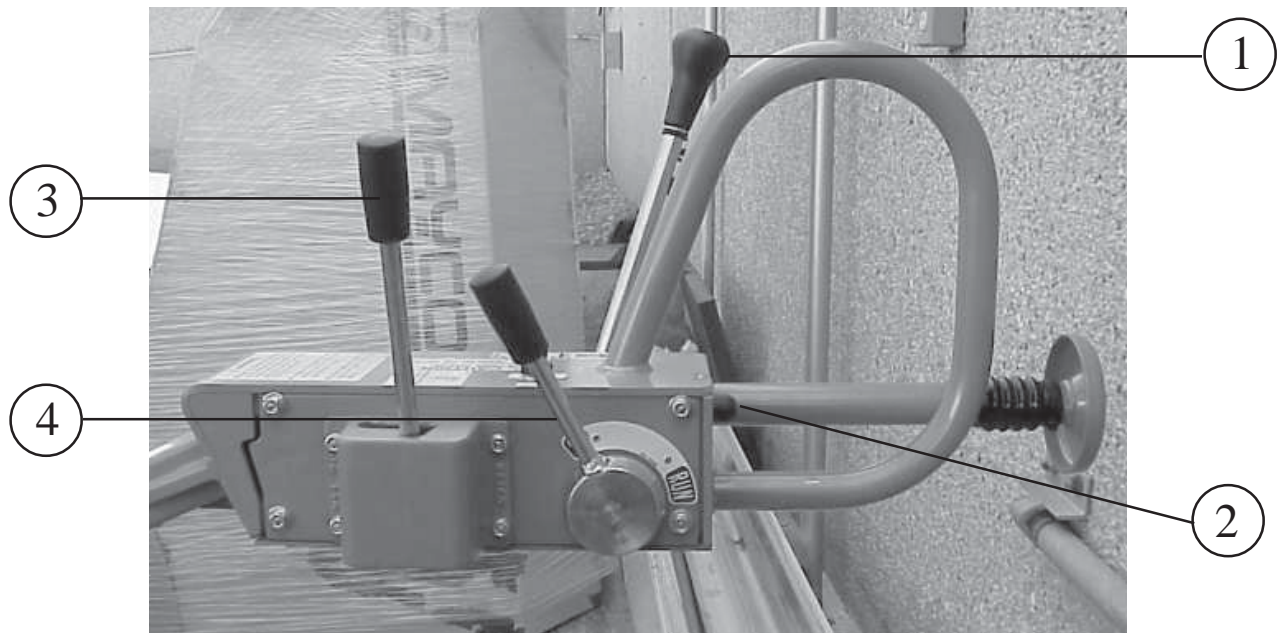

Figure 4. MRH-800GS Lever Components

## HANDLE BAR/LEVER COMPONENTS

Figure 4 illustrates the location of the major lever components on the handle bar of the machine. Each component is described below:

1. **Travel Lever** – Controls the direction of travel of the machine (forward and reverse).
4. **Horn Button** – When pressed, gives a warning sound of the machine approaching.
3. **Vibration Lever** – Turns vibration on and off.
4. **Throttle Lever** – Controls the start up of the machine.
5. **Dead-Man Device** – When pressed or hit while traveling in reverse, causes the travel lever to return to neutral position to stop the machine.
6. **Light ON/OFF Switch** - Turns headlight on and off.

# MRH-800GS — ENGINE COMPONENTS

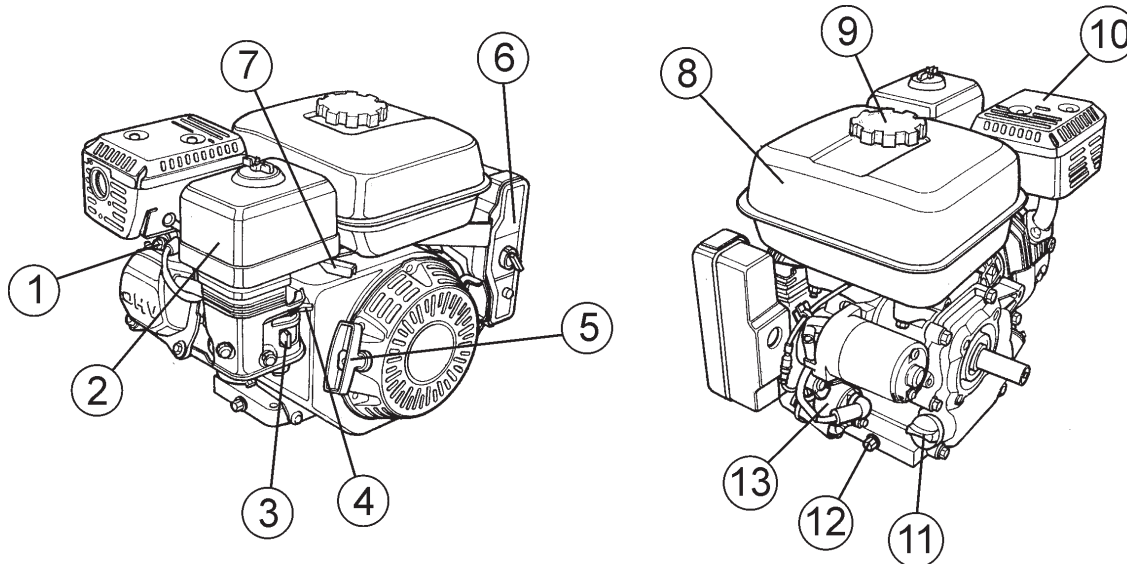
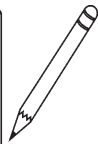
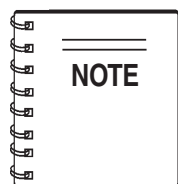

Figure 5. Engine Controls and Components

## INITIAL SERVICING

The engine (Figure 5) must be checked for proper lubrication and filled with fuel prior to operation. Refer to the manufacturers engine manual for instructions & details of operation and servicing.

1. **Spark Plug** – Provides spark to the ignition system. Set spark plug gap to 0.6 - 0.7 mm (0.028 - 0.031 inch) Clean spark plug once a week.
2. **Air Cleaner** – Prevents dirt and other debris from entering the fuel system. Remove wing-nut on top of air filter cannister to gain access to filter element.
3. **Fuel Valve Lever** – **OPEN** to let fuel flow, **CLOSE** to stop the flow of fuel.



Operating the engine without an air filter, with a damaged air filter, or a filter in need of replacement will allow dirt to enter the engine, causing rapid engine wear.

4. **Choke Lever** – Used in the starting of a cold engine, or in cold weather conditions. The choke enriches the fuel mixture.
5. **Recoil Starter (pull rope)** – Manual-starting method. Pull the starter grip until resistance is felt, then pull briskly and smoothly.
6. **Engine ON/OFF Switch** – **ON** position permits engine starting, **OFF** position stops engine operations.
7. **Throttle Lever** – Used to adjust engine RPM speed (lever advanced forward **SLOW**, lever back toward operator **FAST**).
8. **Fuel Tank** – Holds unleaded gasoline. For additional information refer to engine owner's manual.

9. **Fuel Filler Cap** – Remove this cap to add unleaded gasoline to the fuel tank. Make sure cap is tightened securely. **DO NOT** over fill.
10. **Muffler** – Used to reduce noise and emissions.
11. **Engine Oil Filler Cap/Dipstick** – Remove to check amount



**DANGER**

Adding fuel to the tank should be done only when the engine is stopped and has had an opportunity to cool down. In the event of a fuel spill, **DO NOT** attempt to start the engine until the fuel residue has been completely wiped up, and the area surrounding the engine is dry.

and condition of oil in crankcase. Refill or replace with



**WARNING**

Engine components can generate extreme heat. To prevent burns, **DO NOT** touch these areas while the engine is running or immediately after operating. **NEVER** operate the engine with the muffler removed.

recommended type oil as listed in table 2. .

12. **Oil Drain Plug** – Remove to drain crankcase oil.
13. **Engine Starter** – Starts engine when ignition key is rotated to the **“ON”** position.



## DANGER



**NEVER** operate the compactor in a confined area or enclosed area structure that does not provide ample **free flow of air**.



**ALWAYS** wear approved eye and hearing protection before operating the compactor.

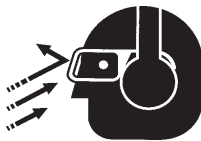

### Before Starting

1. Read safety instructions at the beginning of manual.
2. Remove dirt and dust, particularly in the engine cooling air inlet, carburetor and air cleaner.
3. Check the air filter for dirt and dust. If air filter is dirty, replace air filter with a new one as required.
4. Check carburetor for external dirt and dust. Clean with dry compressed air.
5. Check fastening nuts and bolts for tightness.
6. Understand the geographical features and regulations of the job site.



### Engine Oil Check

1. To check the engine oil level, place the compactor on secure level ground with the engine stopped.
2. Remove the filler dipstick from the engine oil filler hole (Figure 6) and wipe clean.

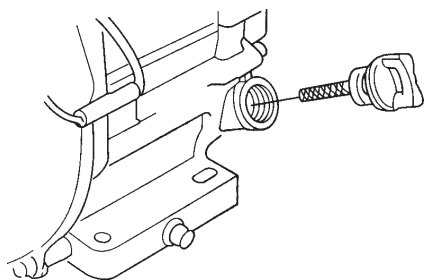

Figure 6. Engine Oil Level

TABLE 4. OIL TYPE

Season	Temperature	Oil Type
Summer	25°C or Higher	SAE 10W-30
Spring/Fall	25°C~10°C	SAE 10W-30/20
Winter	0°C or Lower	SAE 10W-10

3. Insert and remove the dipstick without screwing it into the filler neck. Check the oil level shown on the dipstick.
4. If the oil level is low, fill to the edge of the oil filler hole with the recommended oil type (Table 3). Maximum oil capacity is 1.16 quarts (1.1 liters).

### Checking The Hydraulic System

1. Check the oil tank level gauge (Figure 7). Oil level should be at the middle indication of the gauge or higher. Fill as required
2. Check the surroundings of the oil tank, hydraulic pump and motor for oil leakage.

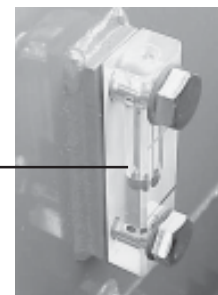

Level should be middle of gauge or higher

Figure 7. Hydraulic System Oil Level Gauge

## DANGER



Always keep hands and fingers away from pinch points. Do not allow anyone to reach in on dangerous sections of the machine to avoid any accidents.

### Checking The V-Belt

1. Remove the 2 bolts, one on each side of the center cover, with a #13 socket wrench. Open the center cover of the machine and support it with the strut by inserting its end to the hole in the base (Figure 8).
2. Check V-belt for proper tension. Insufficient tension causes weak vibration.

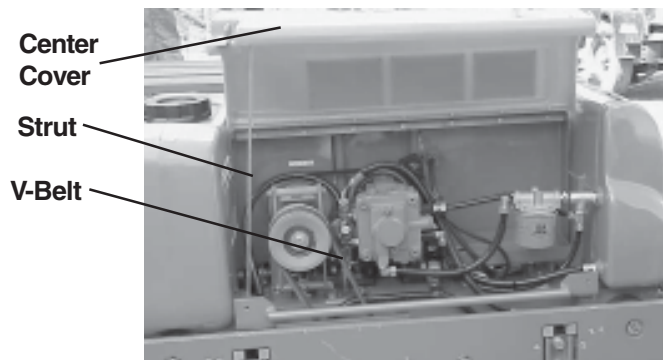

Figure 8. Checking V-Belt Tension

## Checking The Vibrator Oil Level

1. Check vibrator casing for any oil leakage.
2. If any leakage is noticed, remove the level plug on the side of the plate (Figure 9).
3. Check the oil level.

Vibrator Oil Level Plug

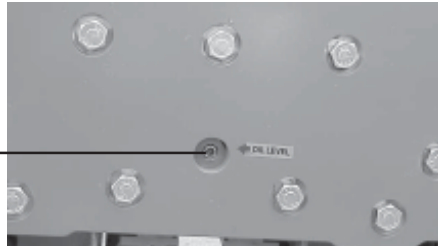

Figure 9. Checking Vibrator Oil Level

## Fuel Check

1. Remove the fuel cap located on top of the engine fuel tank.
2. Visually inspect to see if the fuel level is low. If fuel is low, replenish with unleaded gasoline using a strainer for filtration. **DO NOT** top-off fuel. Wipe up any spilled fuel *immediately!*

## DANGER



Motor fuels are highly flammable and can be dangerous if mishandled. **DO NOT** smoke while refueling.

**DO NOT** attempt to refuel the pump if the engine is *hot!* or *running*.



## Checking Water Tank

1. Check the water tank to see if filled. Add water if necessary. The water tank has a capacity of approximately 10 gallons (40 liters) (Figure 10).



Figure 10. Checking Water Tank

## CAUTION :



Be careful not to confuse the water tank with the oil tank.

## Checking Levers and Horn

1. Check travel, vibration, and throttle levers to make sure they are functioning properly (Figure 4).
2. With travel lever placed in reverse, push the deadman device and verify that the travel lever returns to neutral position. The travel lever stays in neutral position once the deadman device is released.
3. Press the horn and verify that it functions properly.

## Checking Scrapers

1. Check scrapers and make sure that they are not clogged with mud, bent or damaged (Figure 11).
2. Adjust clearance between drums and scrapers as necessary.

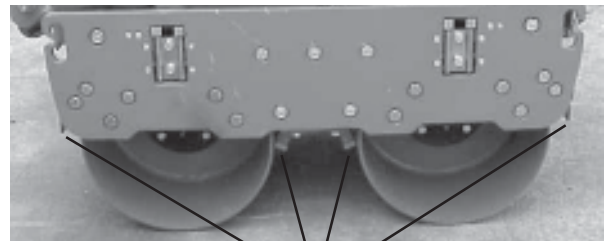

Scrapers

Figure 11. Checking Scrapers

## Checking Bolts, Nuts and Screws

1. Check bolts, nuts, and screws on various parts of the machine, including the engine, for proper tightness.

## Positioning the Handle Bar

1. Release the handle bar release pin (Figure 12) and position the handle bar to the lowered position before starting operation.
2. When machine is not in use, release the handle bar release pin and position the handle bar to the upright position.

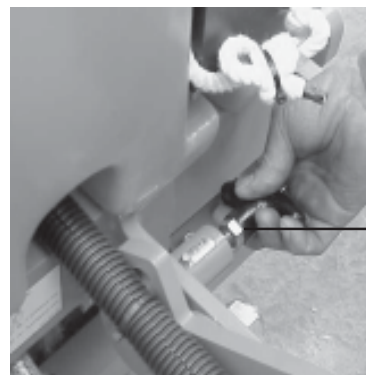

Handle Bar Release Pin

Figure 12. Positioning the Handle Bar

## STARTING THE ENGINE

The engine can be started by motor (electric) or manually (recoil). Refer to Figures 3 and 4 for the location of controls and components.

### CAUTION :



Make sure to follow all safety rules referenced in the safety section of this manual before operating roller. Keep work area clear of debris and other objects that could cause damage to the roller or bodily injury.

### CAUTION :



When the engine is running, **NEVER** turn the starter key to the **START** position

### Electric Start

1. On the control handle:
  - A. Move the *throttle lever* to the **RUN** position.
  - B. Move the *travel lever* to the **NEUTRAL** position.
  - C. Move the *vibration lever* to the **OFF** position.
2. Place the engine *fuel valve lever* (Figure 13) to the "ON" position.

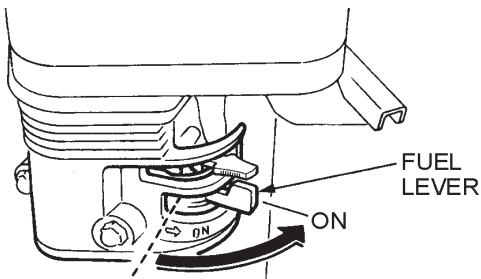

Figure 13. Engine Fuel Valve Lever (ON Position)

3. Place the *choke lever* (Figure 14) in the "OPEN" position if starting a **cold** engine.

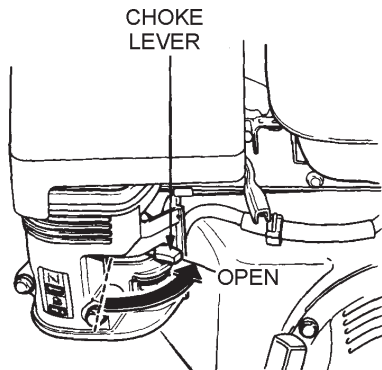

Figure 14. Engine Choke Lever (Open)

4. Place the *choke lever* (Figure 15) in the "CLOSED" position if starting a **warm engine** or the **temperature is warm**.

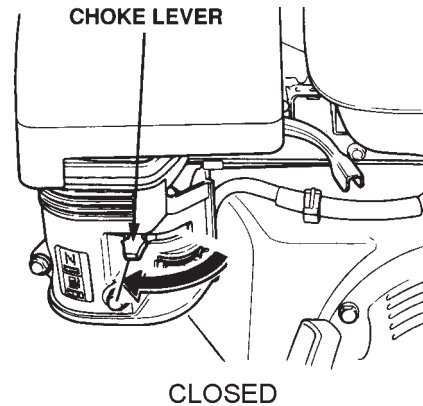

Figure 15. Engine Choke Lever (Closed)

5. Place the *engine ON/OFF switch* (Figure 16) in the "ON" position.

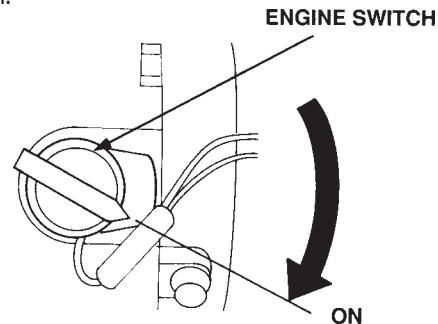

Figure 16. Engine ON/OFF Switch (ON Position)

7. If the engine has started, slowly return the choke lever (Figure 17) to the **CLOSED** position. If the engine has not started repeat steps 1 through 6.

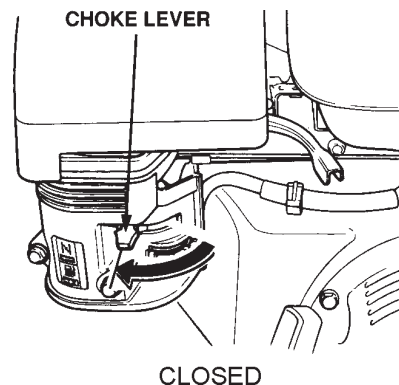

Figure 17. Choke Lever (Closed)

8. Before the roller is placed into operation, run the engine for several minutes. Check for fuel leaks, and noises that would be associated with a loose component.

## Recoil Start

1. On the control handle:
  - A. Move the *throttle lever* to the **RUN** position.
  - B. Move the *travel lever* to the **NEUTRAL** position.
  - C. Move the *vibration lever* to the **OFF** position.
2. Place the engine *fuel valve lever* (Figure 18) to the "ON" position.

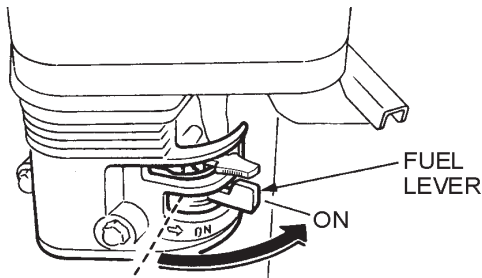

Figure 18. Engine Fuel Valve Lever (ON Position)

3. Place the *choke lever* (Figure 19) in the "OPEN" position if starting a *cold* engine.

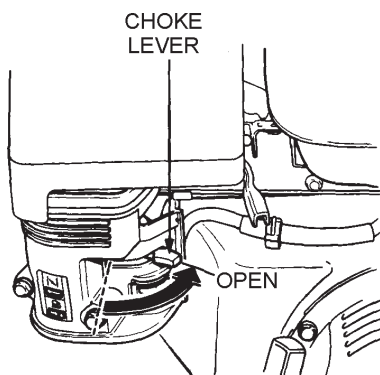

Figure 19. Engine Choke Lever (Open)

4. Place the *choke lever* (Figure 20) in the "CLOSED" position if starting a *warm engine* or the *temperature is warm*.

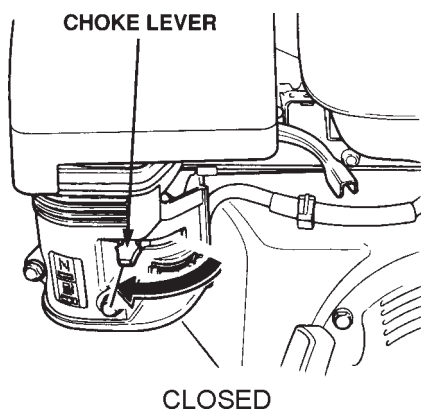

Figure 20. Engine Choke Lever (Closed)

6. Grasp the starter grip (Figure 21) and slowly pull it out. The resistance becomes the hardest at a certain position, corresponding to the compression point. Pull the starter grip briskly and smoothly for starting.

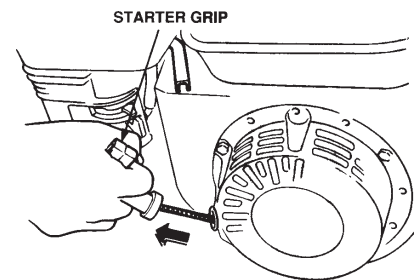

Figure 12. Starter Grip

7. If the engine has started, slowly return the choke lever (Figure 22) to the **CLOSED** position. If the engine has not started repeat steps 1 through 6.

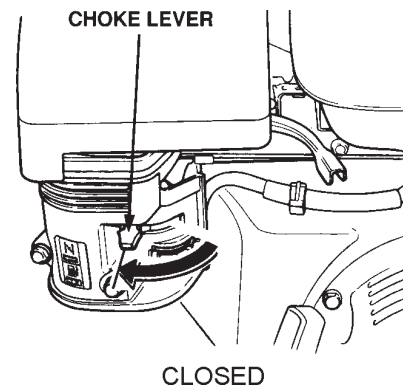

Figure 22. Choke Lever (Closed)

8. Before the roller is placed into operation, run the engine for several minutes. Check for fuel leaks, and noises that would be associated with a loose component.

## TRAVELING

1. Before starting to travel, make sure to release parking brake located on the left side of the rear roller. If the parking brake lever is tight, moving the roller back and forth will make it easier (Figure 23).



Parking Brake (Released Position)

Figure 23. Parking Brake

2. With the throttle lever in the **RUN** position, increase the engine rotation.
3. Push the travel lever forward slightly. This will cause the roller to travel forward at slow speed.
4. To increase the travel speed, push the travel lever further.
5. Travel speed can be varied between 0 and 3 km/h (both forward and reverse).
6. Push the travel lever backward to go in the reverse direction.

## CAUTION :



**DO NOT** reduce speed during work. When shifting travel lever from forward to reverse, be sure to stop the lever at the **NEUTRAL** position first before moving the lever to the opposite direction. **DO NOT** shift the lever from forward to reverse (or reverse to forward) in one motion.

## CAUTION :



After test travel, shut down engine and check for any problems including oil leakage. If any trouble is found, correct the problem before attempting to operate the roller again.

## VIBRATING

1. Shift the vibration lever away from its off position. The vibration lever will automatically spring forward and the roller will start vibrating (Figure 24).



Off Position of Vibration Lever

Figure 24. Vibration Lever

## CAUTION :



Using vibration with clutch slipping causes the clutch to burn. Also, vibration should not be used over completely compacted area, paved road surface, or with stationary roller.

## WATERING

1. For watering work, turn the water cocks clockwise, at the rear of the machine, to start sprinkling. (Figure 25).

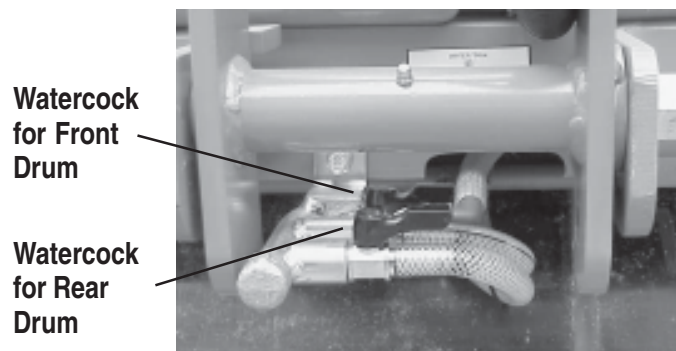

Figure 25. Water Cocks

## SAFETY FEATURES

1. A horn is provided to warn of approach.
2. The dead man device prevents accidental traveling in reverse. It automatically makes the travel lever return to neutral position by stopping the machine when an object comes in contact with the dead man device.

## STOPPING

1. With travel lever in the neutral position, and the vibration lever in the off position, return the throttle lever to the **START** position. Allow the machine to cool down for 3 to 5 minutes.
2. Push the throttle lever forward to stop the engine. In a motor start, return the key switch to the **STOP** position as soon as the engine stops.

## CAUTION :



Neglecting to return the key switch to the **STOP** position will cause the battery to discharge making start up impossible the next time.

3. After the engine stops, close the fuel cock.
4. Lock the parking brake by pulling the brake lever and rotating it 90 degrees clockwise.

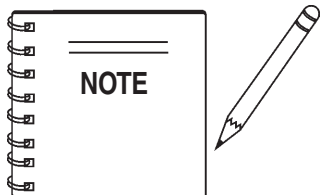

Parking brake system should always be kept clean to avoid mud deposits.

## UNLOADING

1. If you need to move the roller by pushing it manually once engine is stopped, loosen bolt of bypass valve on oil pump by one rotation counterclockwise. This will cause the hydraulic break to disengage and allow the roller to be moved more easily (Figure 26).
2. After moving, tighten the bolt again. Tightening torque is 55 to 70 kgf-cm.

Bypass  
Valve  
Bolt

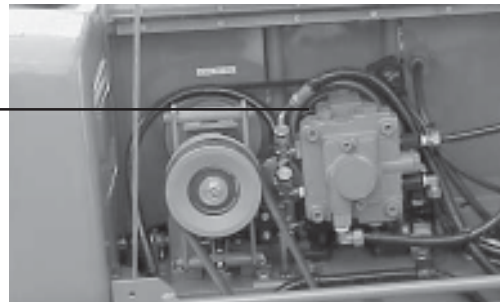

Figure 26 Location of Bypass Valve Bolt

## CAUTION :



**NEVER** tow roller with any type of vehicle. Doing so will damage the hydraulic system.  
**NEVER** perform unloading procedure on a slope. This may cause roller to roll down if parking brake or blocking is deficient.

## LIFTING

1. Use a crane or lift to load and unload the machine. A skilled crane operator is required to perform the job.
2. When lifting the machine, check for any damaged or loose bolts, lifting hooks, and shock mounts.
3. Check any damaged or loose bolts in the guard frame to avoid machine sliding off.
4. Make sure that the machine is shut off before machine is lifted.
5. Use reliable cable for lifting.
6. **ALWAYS** lift the machine vertically and keep the machine away from workers and animals.
7. **DO NOT** lift the machine higher than the required height.

## TRANSPORTING

1. **ALWAYS** make sure that the machine is shut off while being transported.
2. Check that the fuel cap is properly closed and tightened.
3. When traveling long distances or on rugged terrain, drain the fuel of the machine before transporting.
4. Tie down the machine securely on the transportation so that it will not move or topple over.

## CAUTION:



Inspection and other services should **always** be carried out on hard and level ground with the engine shutdown.

### Inspection and Maintenance Service Tables.

- To make sure your roller is always in good working condition before using, carry out the maintenance inspection in accordance with Tables 5 through 7.

**TABLE 5. MRH-800GS MACHINE INSPECTION**

ITEM	HOURS OF OPERATION	REMARKS
Loose or Missing Screws	Every 8 hours (every day)	
Damaged Parts	Every 8 hours (every day)	
Function of Controlling System Part	Every 8 hours (every day)	
Hydraulic System Leak	Every 100 hours	
Vibrator Oil Check	Every 100 hours	See page 23
Vibrator Oil Replacement	Every 300 hours	See page 23
Hydraulic Oil Check	Every 100 hours	See page 23
Hydraulic Oil Replacement	First after 200 hours, then every 1,000 hours	See page 24
V-belt (clutch) Check	Every 200 hours	See page 23

## CAUTION:



These inspection intervals are for operation under normal conditions. Adjust your inspection intervals based on the number hours roller is in use, and particular working conditions. Fuel piping and connections should be replaced every 2 years.

**TABLE 6. MRH-800GS ENGINE CHECK**

ITEM	HOURS OF OPERATION
Spark Plug Check	Every 40 hours (every week)
Oil or Fuel Leak	Every 8 hours (every day)
Tightness of Fastening Threads	Every 8 hours (every day)
Engine Oil Check and Replenishment	Every 8 hours (every day) (Replenish to specified maximum level)
Engine Oil Replacement	After first 25 hours then every 50 to 100 hours
Air Filter Cleaning	Every 100 hours
See separate engine manual for details on engine check.	

### Daily Service

- Check for leakage of fuel or oil.
- Check for loose screws including tightness. See Table 7 below (tightening torque), for retightening:

**TABLE 7. TIGHTENING TORQUE (in. kg/cm) DIAMETER**

Material	6mm	8mm	10mm	12mm	14mm	16mm	18mm	20mm
4T	70	150	300	500	750	1,100	1,400	2,000
6-8T	100	250	500	800	1,300	2,000	2,700	3,800
11T	150	400	800	1,200	2,000	2,900	4,200	5,600
*	100	300~350	650~700					

\* (In case counter-part is of aluminum)  
(Threads in use with this machine are all right handed)  
Material and quality of material is marked on each bolt, and screw.

- Remove soil and clean the bottom of compaction plate.
- Check hydraulic pump, piping and hose for any leakage. A loosened hydraulic hose can be a cause for leakage. Check hydraulic hose connections with wrench applied for tightness.
- Check engine oil.

## Spark Plug

1. Remove and clean the spark plug (Figure 27).
2. Adjust the spark gap to 0.028 ~0.031 inch (0.6~0.7 mm). This unit has electronic ignition, which requires no adjustments.

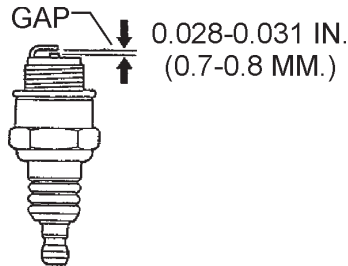

Figure 27. Spark Plug Gap

## Engine Oil Replacement

1. Replace engine oil, first in 25 hours of operation and every 50 to 100 hours afterwards.
2. Drain the engine oil when the oil is **warm** as shown in Figure 28.
3. Remove the oil drain bolt and sealing washer and allow the oil to drain into a suitable container.
4. Replace engine oil with recommended type oil as listed in Table 3. Engine oil capacity is 1.16 quarts (1.1 liters). **DO NOT** overfill.
5. Install drain bolt with sealing washer and tighten securely.

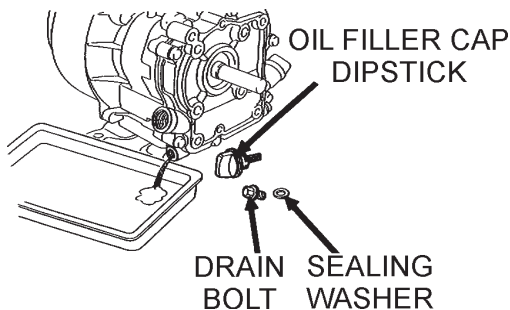

Figure 28. Engine Oil (Draining)

## Air Filter

1. Remove the air cleaner cover and foam filter element as shown in Figure 23.
2. Tap the paper filter element (Figure 29) several times on a hard surface to remove dirt, or blow compressed air [not exceeding 30 psi (207 kPa, 2.1 kgf/cm<sup>2</sup>)] through the filter element from the air cleaner case side. **NEVER** brush off dirt. Brushing will force dirt into the fibers. Replace the paper filter element if it is excessively dirty.
3. Clean foam element in warm, soapy water or nonflammable solvent. Rinse and dry thoroughly. Dip the element in clean engine oil and completely squeeze out the excess oil from the element before installing.

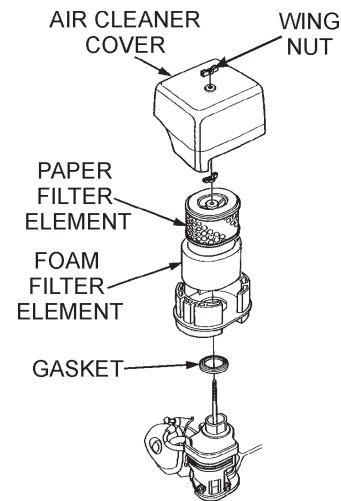

Figure 29. Engine Air Filter

## ROLLER INSPECTION AND ADJUSTMENT

1. Refer to Table 7 for oil and grease requirements.
2. Check oil tank level daily.
3. Check the machine for oil leak and proper function of lever, cables, and links daily.

## MACHINE MAINTENANCE

1. At the end of each day's operation, wash down dust and dirt off the machine. Clean area around drums and scrapers making sure all mud is removed.
2. Drain water tank completely.
3. Cover the machine to prevent dust and store in dry place away from sun exposure.

## LONG TERM STORAGE

1. Conduct thorough lubrication and oil change.
2. Disconnect battery terminals and dismount battery from machine. Store battery.
3. If there is a possibility that ambient temperature will drop below freezing point, add antifreeze agent to coolant.
4. Cover the inlet and outlet of air cleaner and muffler securely.
5. Store machine indoors. **DO NOT** leave outdoors.
6. Refer to Table 7 for lubrication necessary for the machine.

## BATTERY MAINTENANCE

### DANGER :



Lead-acid battery contains sulfuric acid, which may damage eyes or skin on contact.



### FOR YOUR SAFETY:

- Always wear a face shield to avoid acid getting into the eyes. If acid gets in contact with eyes, flush immediately with clean water and get medical advice.
- Wear rubber gloves and protective clothes to keep acid off skin. If acid gets in contact with skin, wash off immediately with clean water.
- Use a flashlight to check battery electrolyte level. Always check the engine is stopped.
- **DO NOT** charge battery or jump-start engine when the battery is frozen. Warm the battery to 15 degrees F or battery may explode.
- Replace the battery with the same or similar capacity battery or battery may explode.

- Do not close the exhaust outlet of battery. The gas pressure building up in the battery may cause explosion.
  - Before using a battery charger, read and understand the charger instruction manual thoroughly.
  - Charge the battery in a non-spark, well-ventilated area. Avoid fire from cigarette sparks or matches.
1. If a battery has not been used for some time, reduce the charge level initially to protect each plate inside the battery.
  2. Check the battery terminals periodically to ensure that they are in good condition.
  3. Use wire brush or sand paper to clean the battery terminals.
  4. Check battery for cracks or any other damage. If white pattern appears inside the battery or paste has accumulated at the bottom, replace the battery.
  5. Measure the specific gravity of electrolyte:  
completely charged: 1.270 - 1.290  
needs charging: 1.260 or lower
  6. If the machine will not be in operation for a long period of time, charge the battery sufficiently, tighten all caps, correctly, store in cool dry place and check the battery charge level every month to maintain the performance of the battery.

## BATTERY CABLE CONNECTION

1. When removing cable, disconnect the ground side (normally negative) first (Figure 30).

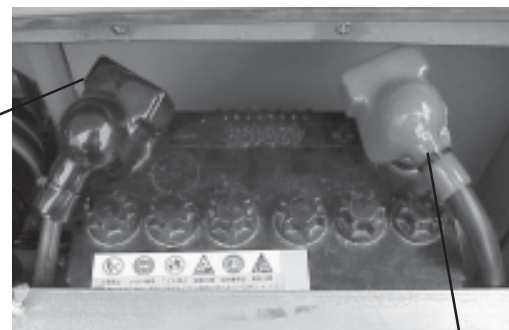

Positive Terminal

Figure 30. Battery Connection

2. When installing cable connect the ground side (normally negative) last.

## FORWARD AND REVERSE TRAVEL ADJUSTMENT

1. If neutral position for forward and reverse travel has been displaced, conduct the neutral adjustment.
2. If roller travels forward with the ball of ball plunger remaining in V slot of the guide, loosen M8 bolt and slide the slide plate slightly toward the engine. If the roller travels backward, slide the plate towards side plate (Figure 31).

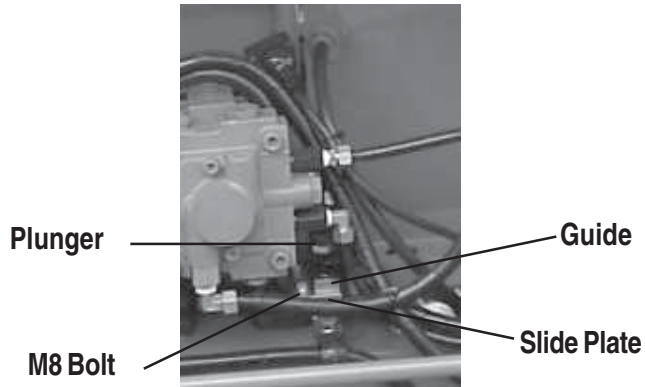

Figure 31. Adjustment of Neutral Position

3. With M8 bolt tightened, start engine and check the neutral for forward and reverse. If still displaced, repeat the procedure.
4. If neutral position of forward/reverse lever has been displaced, use the turn buckle located on the oil pump side of forward/reverse cable.

## VIBRATION CLUTCH ADJUSTMENT

1. Move vibration lever to the **OFF** position.
2. Loosen the front and rear nuts at the end of vibration clutch cable (Figure 32).
3. Turn in the nut on the front side again and at the position that release fork starts to move, turn in the nut by one or two threads. Lock it a this position together with the rear nut.

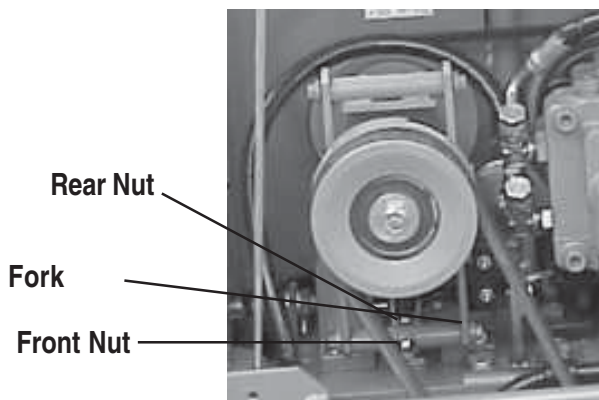

Figure 32. Vibration Clutch Adjustment

## CAUTION:



**NEVER** attempt to check the V-belt with the engine running. Severe injury can occur if your hand gets caught between the V-belt and the clutch (Figure 33). Always use safety gloves.

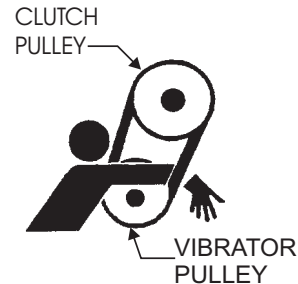

Figure 33. V-Belt Hazard

## CAUTION :



Excessive turning of front nut may cause the sliding engagement of clutch to take place or no vibration takes place even when vibration lever is engaged.

On the other hand, insufficient turn may cause sliding engagement of clutch even when the vibration lever is placed in the **OFF** position or for vibration to remain engaged.

## HYDRAULIC SYSTEM INSPECTION AND SERVICE

1. Check motor and pump for any damage.
2. Check hoses and pipes for proper tightness and make sure there are no leaks.
3. Check nylon tubes for hydraulic oil intake and drain. Retighten brass nut if loose and if a leak is detected. If leak continues after retightening, replace nylon tube, nut and sleeve.
4. Check oil tank for proper oil level using the hydraulic system oil level gauge (See Figure 7). Make sure hydraulic oil has not whitened or emulsified. Whitish color means aeration in pump. Retighten pipe and correct level of oil. Emulsification means water in the hydraulic oil. Replace the oil.

## TABLE 8. MRH-800GS LUBRICATION CHART

ITEM	MAINTENANCE NEEDED	FREQUENCY	TYPE	LOCATION
Vibrator Oil	Replace Oil	Every 300 Hours of Operation	SAE10W30 (1.5 liters)	see Figure 22
Engine Oil	Replace Oil	Initially - After 10 to 20 Hours of Operation Thereafter - Every 50 to 100 Hours of Operation	SAE#30 or SAE10W30 (Spring - Summer)	see Figure 6
			SAE#20 or SAE10W30 (Fall - Winter)	
			SAE10W30 (Extremely Cold Region)	
Hydraulic Oil	Replace Oil	Every 1000 to 1500 Hours of Operation	Viscosity: ISO VG32 equivalent - for cold region ISO VG46 or 56 equivalent - for warm region Shipped from factory with Shell Tellus 46 (25 liters)	see Figure 7
Travel Lever, Vibration Lever, Throttle Lever	Add Lubrication Oil to Sliding Parts	Every 50 Hours of Operation	Lubrication Oil	see Figure 4
Dead Man's Device	Lubricate Grease Fitting	Every 50 Hours of Operation	Grease	see Figure 4
Handle Bar Release Pin	Lubricate Grease Fitting	Every 50 Hours of Operation	Grease	see Figure 37
Bearing Cover	Lubricate Grease Fitting	Every 50 Hours of Operation	Grease	see Figures 35,36
Clutch Box	Lubricate Grease Fitting	Every 50 Hours of Operation	Grease	see Figure 38
Travel Lever	Lubricate Sliding Parts	Every 50 Hours of Operation	Grease	see Figure 4
Oil Filter	Replace Oil Filter	Initially - After 25 Hours of Operation Thereafter - Every 500 Hours of Operation	Mikasa Genuine 10 micron Filter Paper	see Figure 39

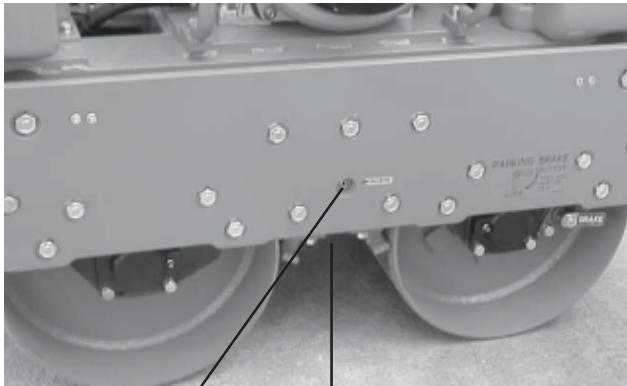

Vibrator Oil Level Plug  
Vibrator Oil Drain Plug  
**Figure 34. Vibrator Oil Maintenance**

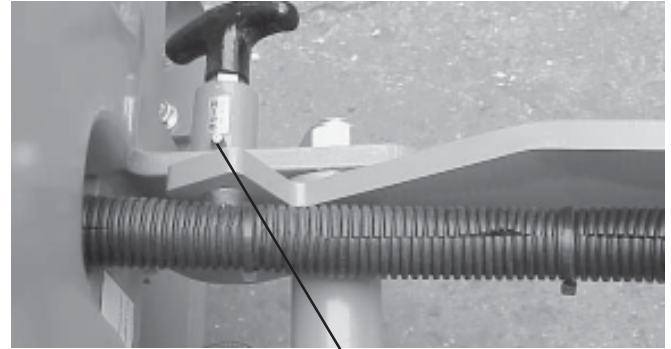

Handle Bar Release Pin Grease Fitting  
**Figure 37. Handle Bar Maintenance**

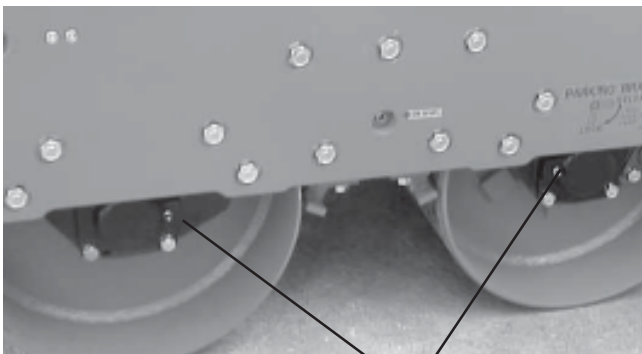

Left Side Bearing Cover Grease Fitting  
**Figure 36. Bearing Cover Maintenance**

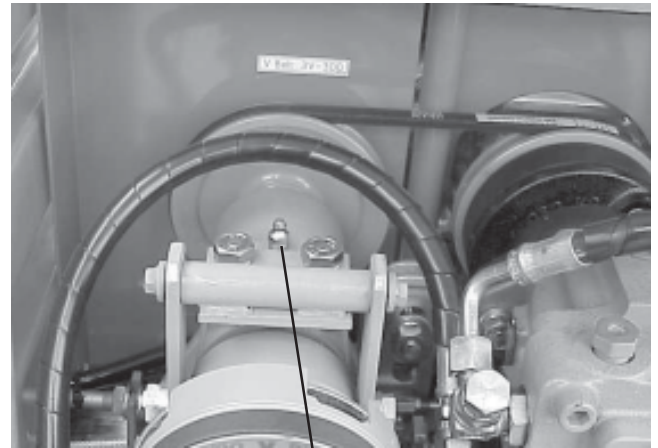

Clutch Box Grease Fitting  
**Figure 38. Clutch Box Maintenance**

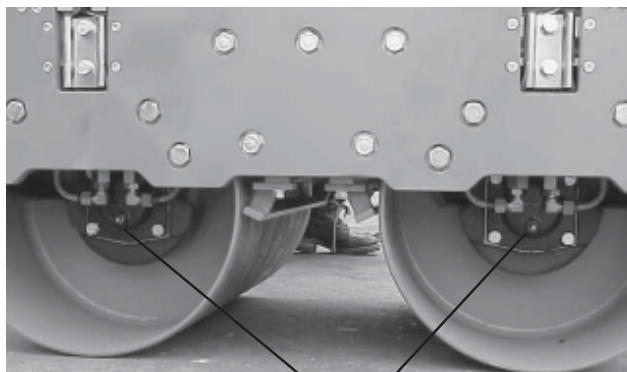

Right Side Bearing Cover Grease Fitting  
**Figure 36. Bearing Cover Maintenance**

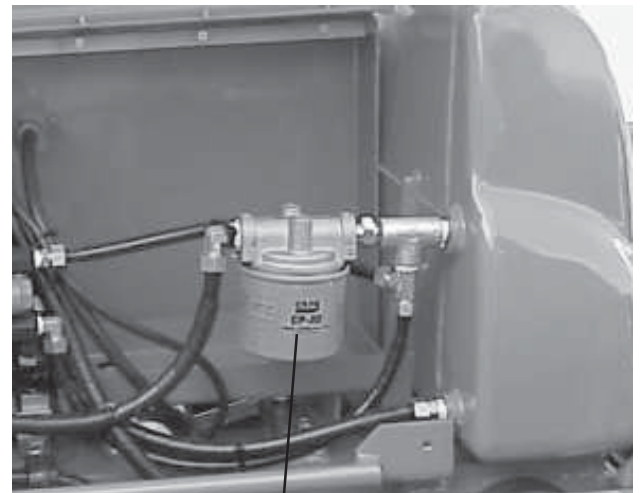

Hydraulic Oil Filter  
**Figure 39. Hydraulic Oil Filter Location**



# MRH-800GS — ROLLER TROUBLESHOOTING

**TABLE 9. TROUBLESHOOTING**

<b>SYMPTOM</b>	<b>POSSIBLE PROBLEM</b>	<b>SOLUTION</b>
Unit does not travel.	Parking brake still engaged?	Release parking brake lever.
Unit does not travel or travel is not smooth.	Defective centrifugal clutch?	Repair or replace clutch.
	Damaged rubber coupling and flange?	Replace rubber coupling and flange.
	Defective travel cable and link?	Repair or replace travel cable and link.
	Damaged scraper or too much mud in scraper?	Replace or repair scraper.
	Damaged or clogged oil filter?	Replace filter.
	Damaged or leaking hydraulic pipe?	Repair or replace parts.
	Low oil level or contaminated oil?	Replenish or replace oil.
	Damaged or leaking hydraulic pump?	Repair or replace hydraulic pump.
	Damaged or leaking hydraulic motor?	Repair or replace hydraulic motor.
	Damaged drum gear and bearing?	Repair parts.
	Bad drum rotation?	Repair or replace drum.
Unit does not vibrate or has weak vibration.	Defective centrifugal clutch?	Repair or replace clutch.
	Damaged or slipping V-belt?	Replace V-belt or adjust tension.
	Damaged vibration cable and linkage?	Replace or repair vibration cable and linkage.
	Damaged vibration clutch?	Adjust or replace clutch.
	Defective clutch vibrator pulley V-belt?	Replace V-belt.
	Vibrator does not turn smoothly with hand?	Check and repair vibrator. Check if oil level is not excessively high.

## TABLE 10. ENGINE TROUBLESHOOTING

SYMPTOM	POSSIBLE CAUSE	SOLUTION
Difficult to start, "fuel is available, but no SPARK at spark plug".	Spark plug bridging?	Check gap, insulation or replace spark plug.
	Carbon deposit on spark plug?	Clean or replace spark plug.
	Short circuit due to deficient spark plug insulation?	Check spark plug insulation, replace if worn.
	Improper spark plug gap?	Set to proper gap.
Difficult to start, "fuel is available, and SPARK is present at the spark plug".	ON/OFF switch is shorted?	Check switch wiring, replace switch.
	Ignition coil defective?	Replace ignition coil.
	Improper spark gap, points dirty?	Set correct spark gap and clean points.
	Condenser insulation worn or short circuiting?	Replace condenser.
	Spark plug wire broken or short circuiting?	Replace defective spark plug wiring.
Difficult to start, "fuel is available, spark is present and compression is normal"	Wrong fuel type?	Flush fuel system, and replace with correct type of fuel.
	Water or dust in fuel system?	Flush fuel system.
	Air cleaner dirty?	Clean or replace air cleaner.
Difficult to start, "fuel is available, spark is present and compression is low"	Suction/exhaust valve stuck or protruded?	Re-seat valves.
	Piston ring and/or cylinder worn?	Replace piston rings and or piston.
	Cylinder head and/or spark plug not tightened properly?	Torque cylinder head bolts and spark plug.
	Head gasket and/or spark plug gasket damaged?	Replace head and spark plug gaskets.
No fuel present at carburetor.	Fuel not available in fuel tank?	Fill with correct type of fuel.
	Fuel cock does not open properly?	Apply lubricant to loosen fuel cock lever, replace if necessary.
	Fuel filter clogged?	Replace fuel filter.
	Fuel tank cap breather hole clogged?	Clean or replace fuel tank cap.
	Air in fuel line?	Bleed fuel line.

**TABLE 10. ENGINE TROUBLESHOOTING (CONTINUED)**

SYMPTOM	POSSIBLE CAUSE	SOLUTION
"Weak in power" compression is proper and does not misfire.	Air cleaner not clean?	Clean or replace air cleaner
	Improper level in carburetor?	Check float adjustment, re-build carburetor.
	Defective Spark plug?	Clean or replace spark plug.
	Defective Spark plug?	
"Weak in power" compression is proper but misfires.	Water in fuel system?	Flush fuel system, and replace with correct type of fuel.
	Dirty spark plug?	Clean or replace spark plug.
	Ignition coil defective?	Replace ignition coil.
Engine overheats.	Spark plug heat value improper?	Replace with correct type of spark plug.
	Correct type of fuel?	Replace with correct type of fuel
	Cooling fins dirty?	Clean cooling fins.
Rotational speed fluctuates.	Governor adjusted correctly?	Adjust governor.
	Governor spring defective?	Replace governor spring.
	Fuel flow restricted?	Check entire fuel system for leaks or clogs.
Recoil starter malfunction.	Recoil mechanism clogged with dust and dirt?	Clean recoil assembly with soap and water.
	Spiral spring loose?	Replace spiral spring.

# EXPLANATION OF CODE IN REMARKS COLUMN

How to read the marks and remarks used in this parts book.

## Section 1: Items Found In the “Remarks” Column

**Serial Numbers-**Where indicated, this indicates a serial number range (inclusive) where a particular part is used.

**Model Number-**Where indicated, this shows that the corresponding part is utilized only with this specific model number or model number variant.

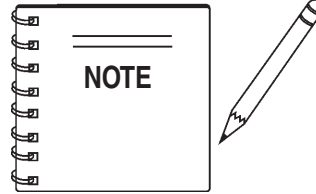

If more than one of the same reference number is listed, the last one listed indicates newest (or latest) part available.

## Section 2: Items Found In the “Remarks” Column

**Serial Numbers-**Where indicated, this indicates a serial number range (inclusive) where a particular part is used.

**Model Number-**Where indicated, this shows that the corresponding part is utilized only with this specific model number or model number variant.

## Section 3: Items Found In the “Items Number” Column

All parts with same symbol in the number column, \*, #, +, %, or ■, belong to the same assembly or kit.

Note: If more than one of the same reference number is listed, the last one listed indicates newest (or latest) part available.

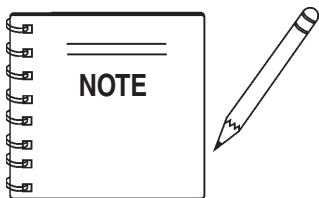

*The contents of this catalog are subject to change without notice.*

**MRH-800DS VIBRATION ROLLER 1 TO 3  
UNITS WITH HONDA GX390K1SM32  
ENGINE**

<b>Qty.</b>	<b>P/N</b>	<b>Description</b>
1	954401890	FILTER, WATER TANK
2	954001380	FILTER, HYDRAULIC OIL
2	070503000	V-BELT, ENGINE
1	956100024	THROTTLE WIRE
1	954300340	CAP, WATER TANK
1	955200030	HEAD LAMP ASSY.
2	070100381	V-BELT, VIBRATOR ASSY.
3	9807956846	SPARK PLUG
3	172107E3010	ELEMENT, AIR CLEANER
1	11428855041	CAP ASSY., FUEL TANK
1	341507H7003	OIL ALERT UNIT
2	35111880003	KEY, STARTER

# MRH-800GS VIBRATION ROLLER — DECAL PLACEMENT

## DECAL PLACEMENT

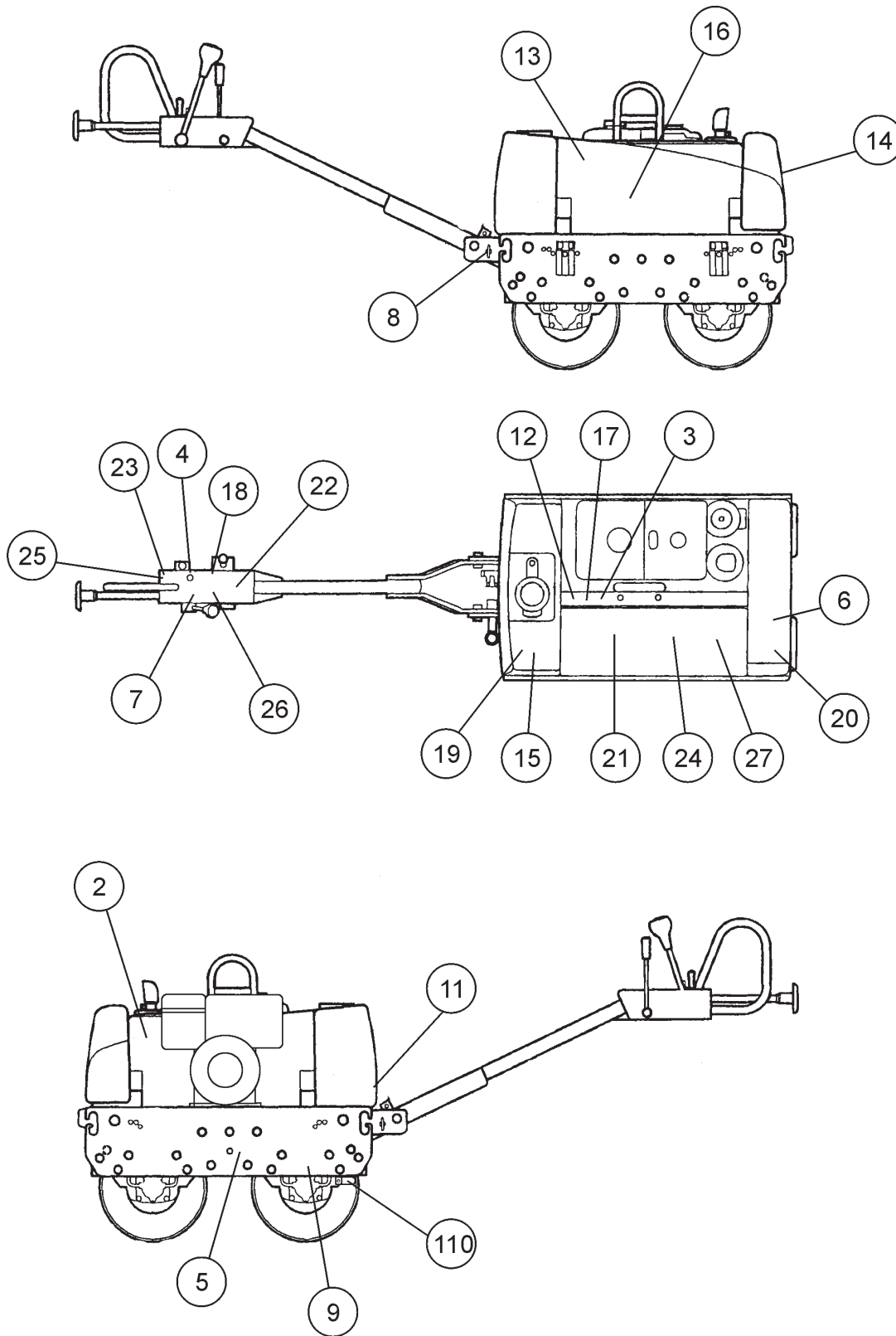

# MRH-800GS VIBRATION ROLLER — DECAL PLACEMENT

## PLACEMENT

<u>NO.</u>	<u>PART NO.</u>	<u>PART NAME</u>	<u>QTY.</u>	<u>REMARKS</u>
1	920205690	DECAL, BRAKE LEVER .....	1 .....	NPA-569
2	9202009660	DECAL, CAUTION - ENGINE SPEED .....	1 .....	NPA-966
3	920206280	DECAL, DANGER - PINCH POINT .....	1 .....	NPA-628
4	920102490	DECAL, LIGHT SWITCH .....	1 .....	NPA-249
5	920101480	DECAL, CHECK OIL LEVEL .....	1 .....	NP-148
6	DCL210	DECAL, MIKASA MOBILE DTE 25	1	
7	920108070	DECAL, FORWARD/REVERSE LEVER .....	1 .....	NPA-507
8	920100120	DECAL, GREASE POINT .....	1 .....	NPA-120
9	920208070	DECAL, PARKING BREAK .....	1 .....	NPA-907
10	920206160	DECAL, CAUTION - INCLINE PARKING .....	1 .....	NPA-616
11	920206200	DECAL, WATER TANK SPRINKLE PIPE .....	1 .....	NPA-620
12	920203330	DECAL, HEARING PROTECTION .....	1 .....	NPA-333
13	920201910	DECAL, MULTIQUIP - CARSON .....	1 .....	NPA-191
14	920101510	DECAL, MIKASA .....	1 .....	NP-151
15	920200320	DECAL, WATER TANK .....	1 .....	NP-32
16	920207610	DECAL, MRH-800GS .....	1 .....	NPA-761
17	920206290	DECAL, CAUTION - OWNERS MANUAL .....	1 .....	NPA-629
18	920202810	DECAL, CAUTION - VIBRATION LEVER .....	1 .....	NPA-281
19	920104280	DECAL, FREEZING PREVENTION .....	1 .....	NPA-428
20	920200470	DECAL, OIL TANK .....	1 .....	NPA-47
21	920202870	DECAL, CAUTION - INSTRUCTIONS PLATE ..	1 .....	NPA-287
22	920205640	DECAL, WARNING - INCLINE PARKING .....	1 .....	NPA-564
23	920105170	DECAL, THROTTLE .....	1 .....	NPA-517
24	920202860	DECAL, CAUTION - MOVING PLATE .....	1 .....	NPA-286
25	920201450	DECAL, HORN .....	1 .....	NPA-145
26	920202920	DECAL, CAUTION - STARTING ENGINE .....	1 .....	NPA-292
27	920205680	DECAL, WARNING - INCLINE PLATE .....	1 .....	NPA-292

# MRH-800GS VIBRATION ROLLER — AXLE ASSY.

AXLE ASSY.

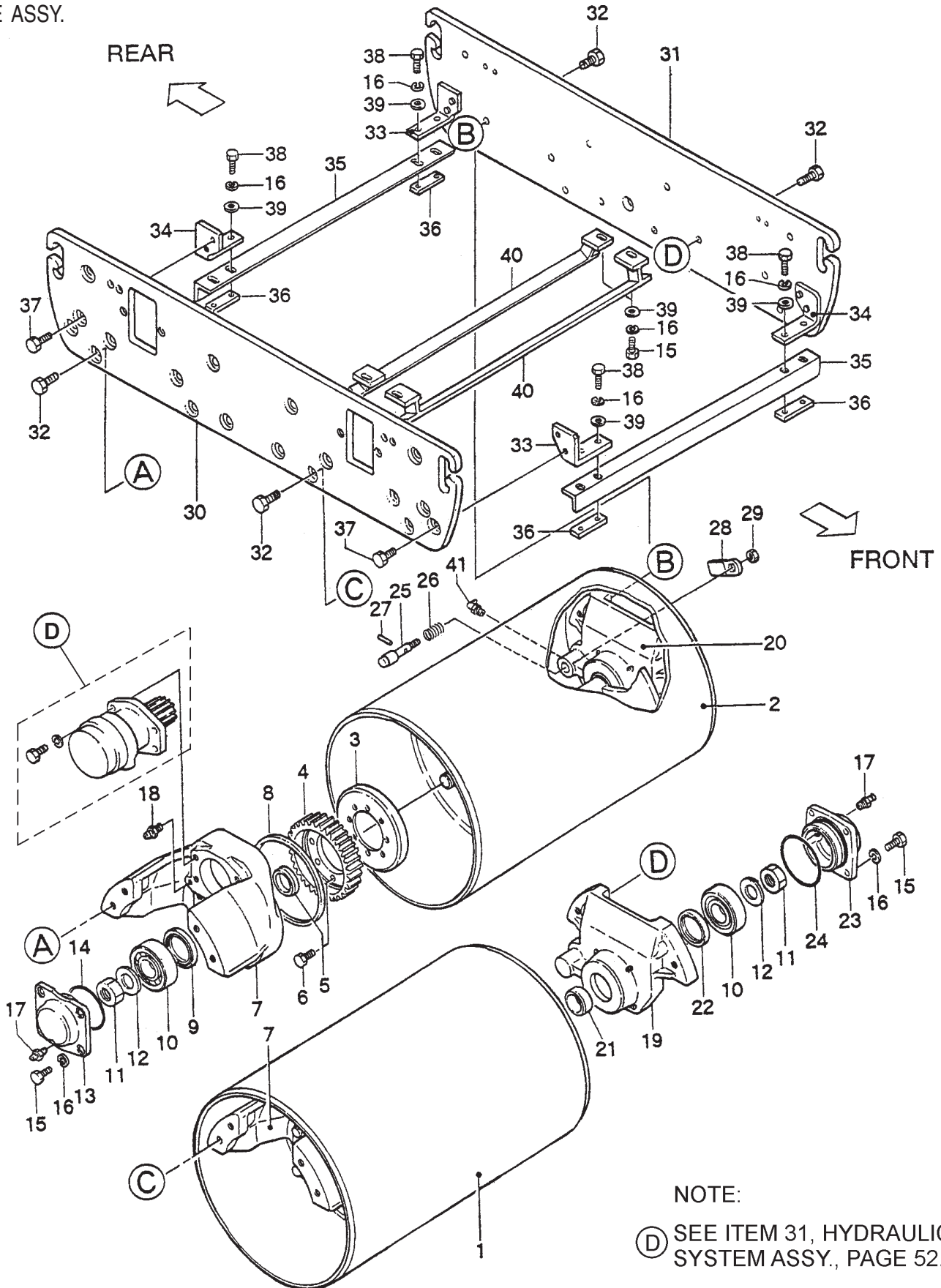

# MRH-800GS VIBRATION ROLLER — AXLE ASSY.

## AXLE ASSY.

<u>NO.</u>	<u>PART NO.</u>	<u>PART NAME</u>	<u>QTY.</u>	<u>REMARKS</u>
1	515112960	DRUM	1	
2	515112970	DRUM	1	
3	515333990	GEAR PLATE	2	
4	515334000	GEAR (39)	2	
5	509429660	COLLAR 405510	2	
6	001121630	BOLT 16X30 T	16	
7	515117050	DRUM BRACKET (R)	2	
8	506425980	FELT (DRUM) 5X5X1200	1	
9	060605020	OIL SEAL VC-55727	2	
10	042006308	BEARING 6308DU	4	
11	020130240	NUT M30, P2.0	4	
12	031130450	WASHER M30	4	
13	515334010	BEARING COVER (R)	2	
14	050100850	O-RING G-85	2	
15	001221025	BOLT 10X25 T	20	
16	030210250	WASHER M10	28	
17	505015060	GREASE FITTING A-PT1/8	4	
18	351010050	GREASE FITTING A-MT6X1	2	
19	515113000	DRUM BRACKET (L)	1	
20	515113010	DRUM BRACKET (LB)	1	
21	506425670	COLLAR 405520	2	
22	060705010	OIL SEAL TB4-55729	2	
23	515334040	BEARING COVER (L)	2	
24	050300950	O-RING S-95	2	
25	515446960	LOCK PUN, BRAKE	1	
26	515446950	SPRING, BRAKE	1	
27	025405025	SPRING PIN 5X25	1	
28	515446970	KNOB, BRAKE	1	
29	020410060	NUT M10, H=6	1	
30	515117040	SIDE PLATE (R)	1	
31	515114350	SIDE PLATE (L)	1	
32	001221430	BOLT 14X30 T	16	
33	515341930	BRACKET (A), SCRAPER	2	
34	515341940	VRACKET (B), SCRAPER	2	
35	515334020	SCRAPER (OUT)	2	
36	515447510	MOUNT NUT, SCRAPER	4	
37	001121435	BOLT 14X35 T	8	
38	001221030	BOLT 10X30 T	8	
39	031110160	WASHER M10	12	
40	515334030	SCRAPER (IN)	2	
41	959010330	GREASE FITTING B-M6FX1	1	

# MRH-800GS VIBRATION ROLLER — BASE ASSY.

BASE ASSY.

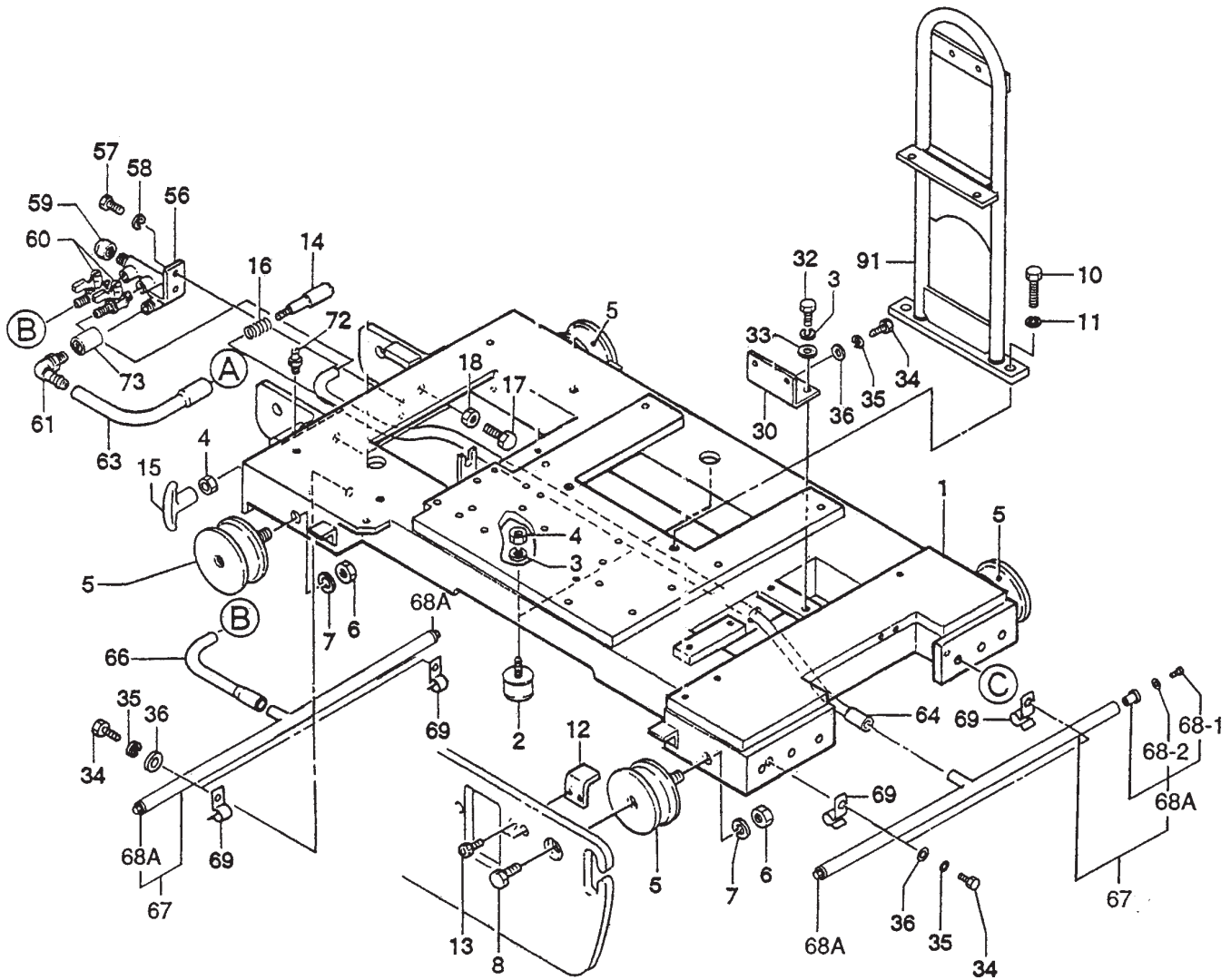

# MRH-800GS VIBRATION ROLLER — BASE ASSY.

BASE ASSY.

<u>NO.</u>	<u>PART NO.</u>	<u>PART NAME</u>	<u>QTY.</u>	<u>REMARKS</u>
1	515114460	BASE (YANMAR-L100)	1	
2	939010010	SHOCK ABSORBER, STOPPER 45	2	
3	030210250	WASHER, LOCK M10	9	
4	020310080	NUT M10	3	
5	930710031	SHOCK ABSORBER RV1-100	4	
6	020316130	NUT M16	4	
7	030216400	WASHER, LOCK M16	4	
8	001221625	BOLT 16X25 T	4	
10	001221440	BOLT 14X40 T	2	
11	030214350	WASHER, LOCK M14	2	
12	515447010	SAFETY GUARD	4	
13	001520815	SOCKET HEAD BOLT 8X13 T	8	
14	501402870	HANDLE STOPPER	1	
15	959010413	EYE NUT M10	1	
15	959010416	T- KNOB (M10)	1	
16	501402880	SPRING / HANDLE (1. 4X18X44)	1	
17	001221230	BOLT 12X30 T	2	
18	0039312000	NUT M12 .....	2	REPLACES 020312100
30	5153344100	STAY, COVER (F)	1	
32	012210020	BOLT 10X20 T .....	5	REPLACES 001221020
33	031110160	WASHER, FLAT M10	7	
34	0105050616	BOLT 6X15 T .....	8	REPLACES 001220615
35	030206150	WASHER, LOCK M6	8	
36	952404470	WASHER, FLAT M6 .....	8	REPLACES 031106100
56	515334050	SUPPORT , WATER COCK	1	
57	014208020	BOLT 8X20 T .....	2	REPLACES 001220820
58	030208200	SWM8	2	
59	509010010	CAP 3/8	1	
60	954403240	COCK PT1/4, BH-1211 (PL)	2	
61	954405660	ELBOW 3/8X12	1	
63	515446980	WATER HOSE (T-V) 300L	1	
64	515446990	WATER HOSE (F) 1200L	1	
66	515447470	WATER HOSE (R) 260L	1	
67	515910030	SPRINKLING PIPE AY MRH	2	INCLUDES ITEMS W/*
68	506425750	CAP, SPRINKLING PIPE	4	
68A*	515910050	CAP AY, W/BOLT, WASHER .....	4	INCLUDES ITEMS W/+
68-1+	001220620	BOLT 6X20 T	4	
68-2+	031106100	WASHER, FLAT M6	4	
69	515449900	CLAMP 00	4	
72	171010120	GREASE FITTING A-M6F	1	
73	954001590	SOCKET PT3/8-3/8	1	
91	515213600	HOOK (L100)	1	
92	515113710	GUARD (L100)	1	
93	001221035	BOLT 10X35T	2	
94	001221020	BOLT 10X20t	2	
95	030210250	WASHER, LOCK M10	4	
96	091004016	WASHER, FLAT M10	4	

# MRH-800GS VIBRATION ROLLER — FRONT GUARD ASSY.

FRONT GUARD ASSY.

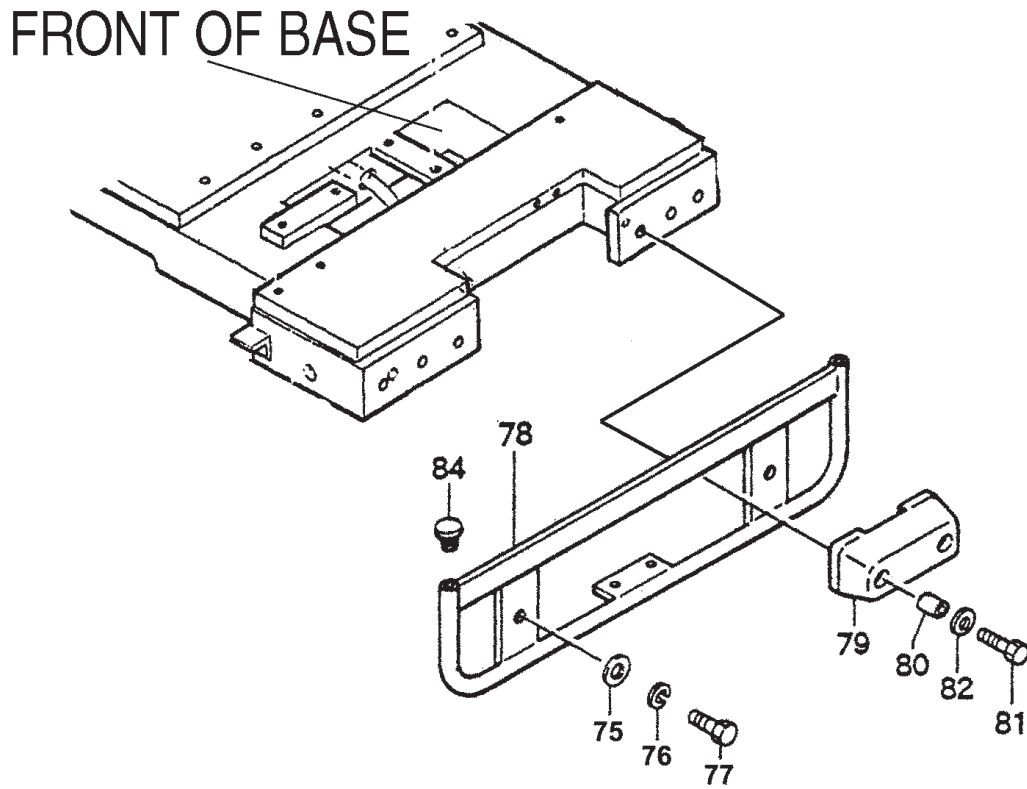

## MRH-800GS VIBRATION ROLLER — FRONT GUARD ASSY.

FRONT GUARD ASSY.

<u>NO.</u>	<u>PART NO.</u>	<u>PART NAME</u>	<u>QTY.</u>	<u>REMARKS</u>
75	031110160	FLAT WASHER, M10	2	
76	030210250	LOCK WASHER, M10	2	
77	001221035	BOLT 10x35 mm	2	
78	515336200	FRONT GUARD	1	
79	515336210	BUMPER	2	
80	515449720	SPACER, BUMPER	4	
81	001221040	BOLT 10X40 T	4	
82	031110160	WASHER, FLAT M10	4	
84	953405940	PIPE INSERT PZ-7	2	

# MRH-800GS VIBRATION ROLLER — SIDE COVER ASSY.

SIDE COVER ASSY.

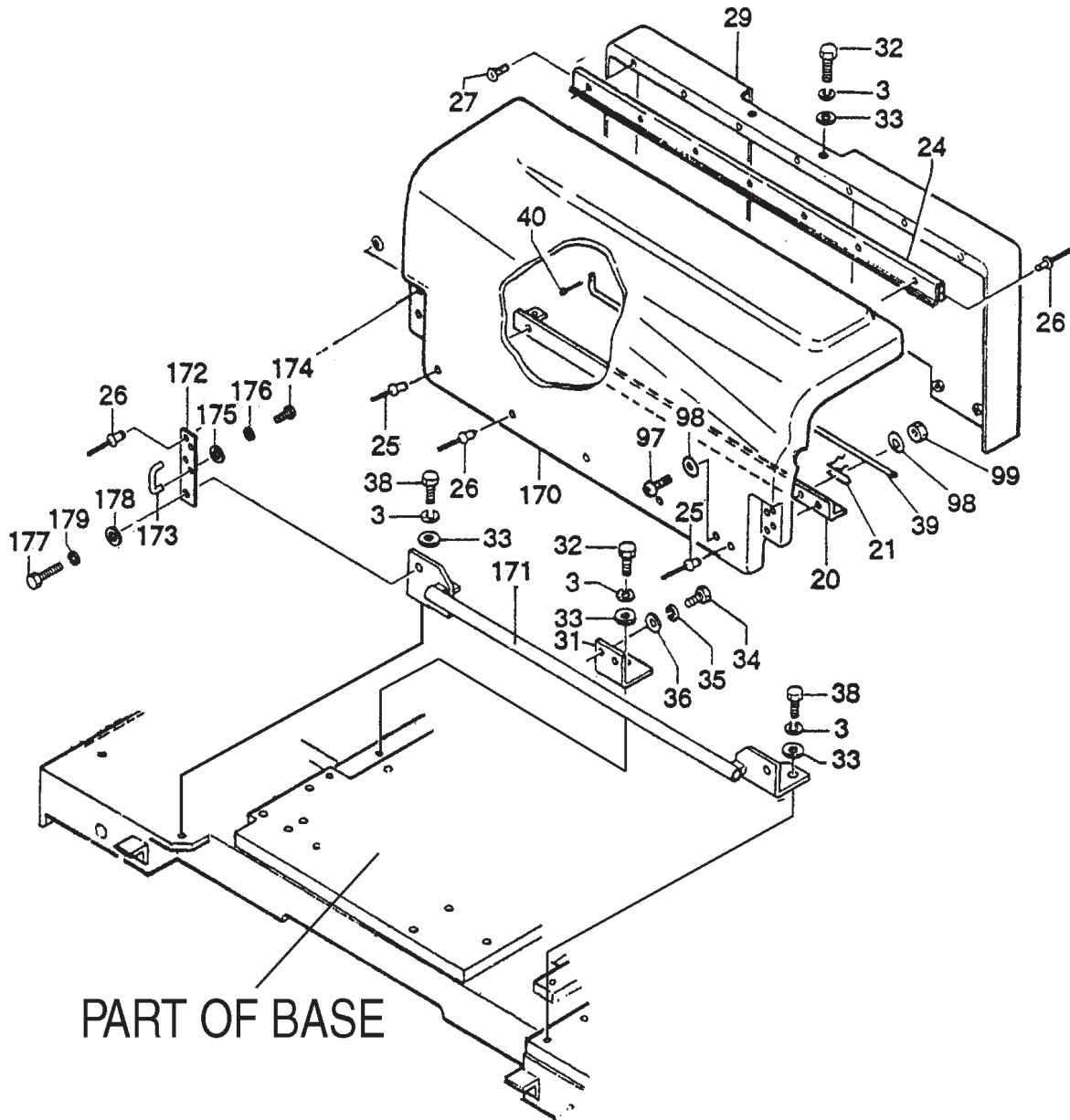

# MRH-800GS VIBRATION ROLLER — SIDE COVER ASSY.

## SIDE COVER ASSY.

<u>NO.</u>	<u>PART NO.</u>	<u>PART NAME</u>	<u>QTY.</u>	<u>REMARKS</u>
3	030210250	WASHER, LOCK M10	9	
20	515336250	SUPPORT, COVER	1	
21	515449890	ROD HOLDER	1	
24	515334600	RUBBER HINGE	1	
25	515010090	RIVET	2	
26	515010100	RIVET	14	
29	515113900	COVER, (ENGINE) HONDA	1	
31	515447030	STAY, COVER (R)	1	
32	012210020	BOLT 10X20 T .....	5	REPLACES 001221020
33	031110160	WASHER, FLAT M10	7	
34	0105050616	BOLT 6X15 T .....	8	REPLACES 001220615
35	030206150	WASHER, LOCK M6	8	
36	952404470	WASHER, FLAT M6 .....	8	REPLACES 031106100
38	0105091025	BOLT 10X25 T .....	2	REPLACES 001221025
39	515447380	ROD, COVER	1	
40	607010080	COTTER PIN 6	1	
97	091004016	SCREW 4X16	1	
98	031104080	WASHER, FLAT M4	2	
99	020304030	NUT M4	1	
170	515114870	COVER (EXP)	1	
171	515214240	STAY, COVER (EXP)	1	
172	515450780	HANDLE BRACKET	2	
173	515450790	HANDLE (COVER)	2	
174	091004015	SCREW 4X15	4	
175	031104080	WASHER, FLAT M4	4	
176	030204100	WASHER, LOCK M4	4	
177	001220815	BOLT 8X15 T	2	
178	031108160	WASHER, FLAT M8	2	
179	030208200	WASHER, LOCK M8	2	

# MRH-800GS VIBRATION ROLLER — WATER TANK ASSY.

WATER TANK ASSY.

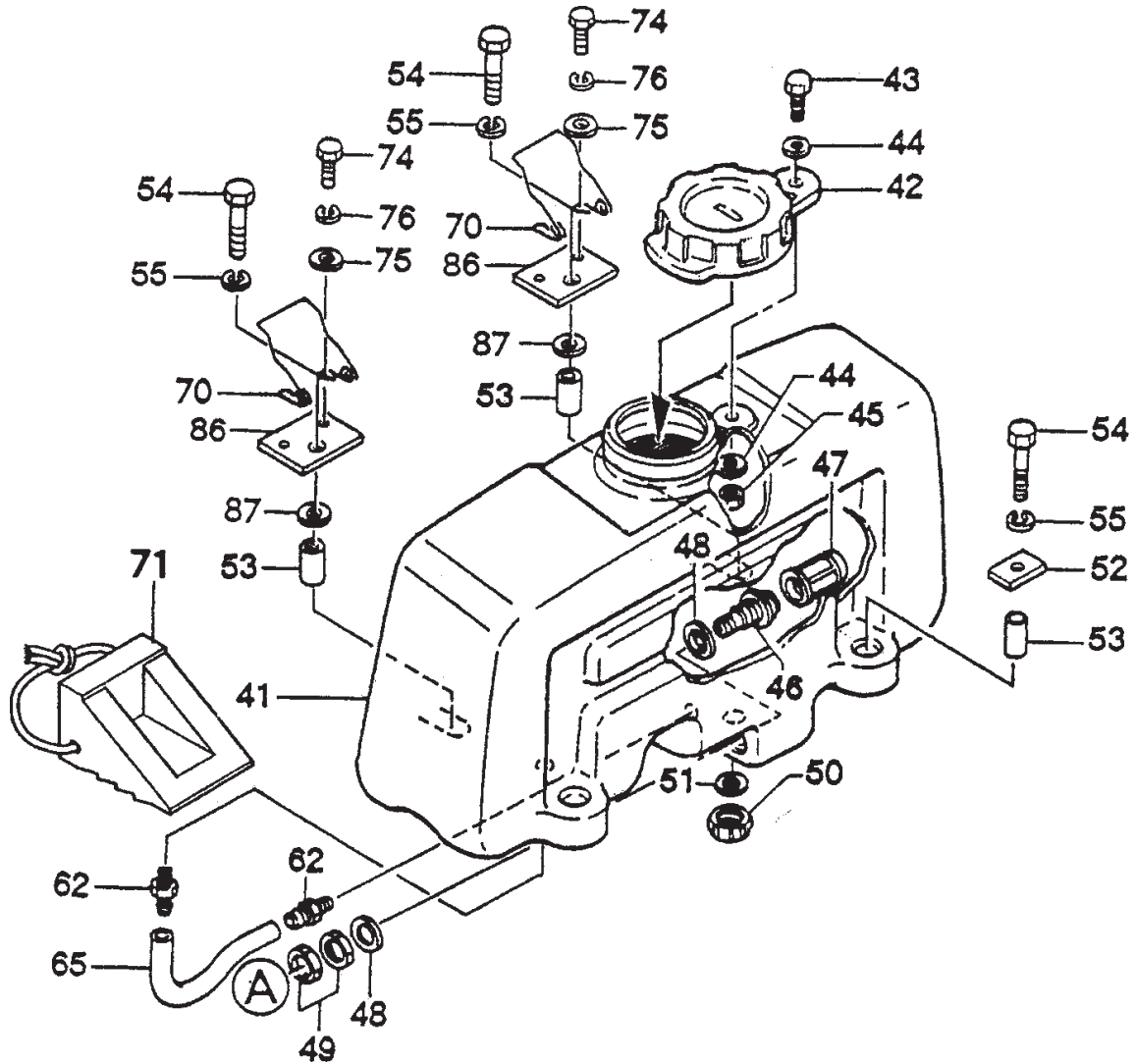

# MRH-800GS VIBRATION ROLLER — WATER TANK ASSY.

WATER TANK ASSY.

<u>NO.</u>	<u>PART NO.</u>	<u>PART NAME</u>	<u>QTY.</u>	<u>REMARKS</u>
41	515114200	WATER TANK	1	
42	954300340	CAP, WATER TANK /MR	1	
43	001241030	BOLT 10X30 U	1	
44	033910010	WASHER 10.5X21X2 SUS	2	
45	022910180	NYLON NUT M10 (SUS)	1	
46	954404910	HOSE JOINT 17D	1	
47	954401890	FILTER, TANK /MR	1	
48	953404900	PACKING 26X36X3	2	
49	959404880	NUT 3/4	2	
50	506403990	CAP PS1	2	
51	953404000	PACKING, CAP PS1	1	
52	506434680	STOPPER, FRONT	2	
53	506434690	SPACER, WATER TANK 39L	4	
54	001221253	BOLT 12X65 T	4	
55	030212300	WASHER, LOCK M12	4	
62	954405680	CONNECTOR 1/4x10	2	
65	515447000	WATER LOSE (T) 280	1	
70	515449870	HOLDER, STOPPER	2	
71	515448290	STOPPER	2	
71	517338540	STOPPER	2	..... G2441-
74	001220610	BOLT 6X10 T	4	
75	031106100	WASHER, FLAT M6	4	
76	030206150	WASHER, LOCK M6	4	
86	515449880	HOLDER (R)	2	
87	952405950	WASHER 13506	2	

# MRH-800GS VIBRATION ROLLER — HYDRAULIC SYSTEM ASSY.

HYDRAULIC SYSTEM ASSY.

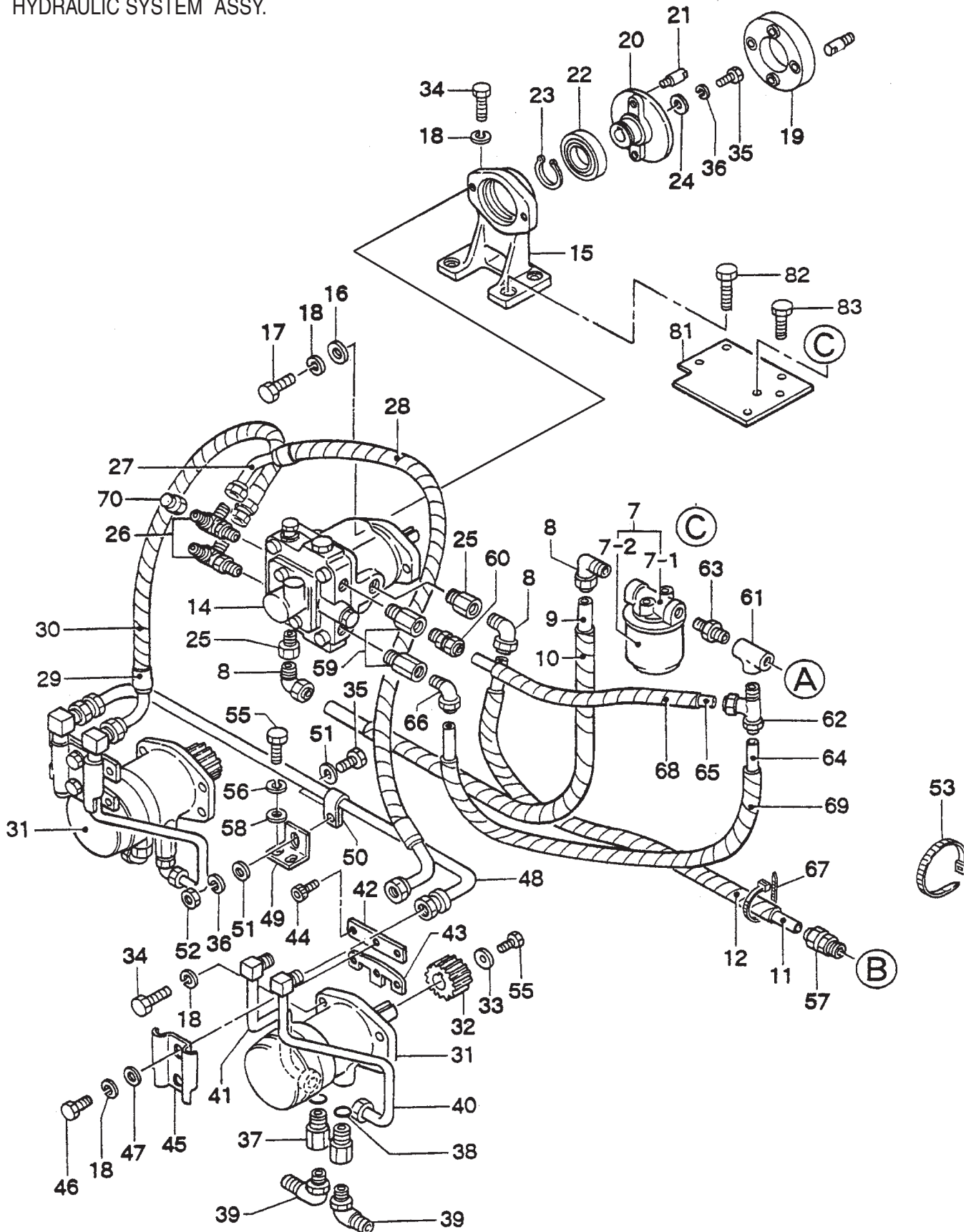

# MRH-800GS VIBRATION ROLLER — HYDRAULIC SYSTEM ASSY.

## HYDRAULIC SYSTEM ASSY.

<u>NO.</u>	<u>PART NO.</u>	<u>PART NAME</u>	<u>QTY.</u>	<u>REMARKS</u>
7	954001350	OIL FILTER CPO 3-80 .....	1	INCLUDES ITEMS W/*
7-1*	954001390	FILTER HEAD	1	
7-2*	954001380	OIL ELEMENT	1	
8	954001530	ELBOW LIN-1/2-PT3/8	3	
9	954001501	TUBE 9.6-12.7 - 300	1	
10	959020011	SPIRAL TUBE 11D-350L	1	
11	954001511	TUBE 9.6-12.7-360	1	
12	955404275	SPIRAL TUBE 11D-400L	1	
14	515010050	OIL PUMP PV10-610	1	
14	515010110	OIL PUMP PV10 -625	1	
15	515114390	BRACKET (PV10)	1	
16	952404110	COLLAR 10225	2	
17	012210035	BOLT 10X35 T .....	2	REPLACES 001221035
18	030210250	WASHER, LOCK M10	22	
19	515334070	COUPLING	1	
20	515334080	FLANGE (PV10)	1	
21	515447020	COUPLING PIN	2	
22	046006009	BEARING 6009DDU	1	
23	080200450	STOP RING S -45	1	
24	952400450	WASHER 7X30X4.5	1	
25	954001460	BUSHING CP-3/8	2	
26	954001710	ELBOW PF3/8 - PF1/4X2	2	
27	954001370	OIL HOSE ML90-ML90X560	1	
27	954001830	OIL HOSE ML90-ML90X560 BS	1	
28	959020013	SPIRAL TUBE 11D-600L	1	
29	516010080	OIL HOSE ML90-1005X600	1	
29	954001840	OIL HOSE ML90-1005X600 BS	1	
30	955404270	SPIRAL TUBE/11D-700L	1	
31	515010040	OIL MOTOR K2355(BLUE)	2	
32	515446940	PINION (12)	2	
33	952400130	WASHER 9304	2	
34	012210035	BOLT 10X35 T .....	14	REPLACES 001221035
35	0105050616	BOLT 6X15 T .....	2	REPLACES 001220615
36	030206150	WASHER, LOCK M6	2	
37	515447130	JOINT 1/2-3/8-31	4	
38	050210180	O-RING P-18-1B	4	
39	512010120	JOINT, LLM-UE-10X3/8-B	4	
40	515447110	PIPE, OM-A-E	2	
41	515447120	PIPE, OM-B-E	2	

# MRH-800GS VIBRATION ROLLER — HYDRAULIC SYSTEM ASSY.

HYDRAULIC SYSTEM ASSY.

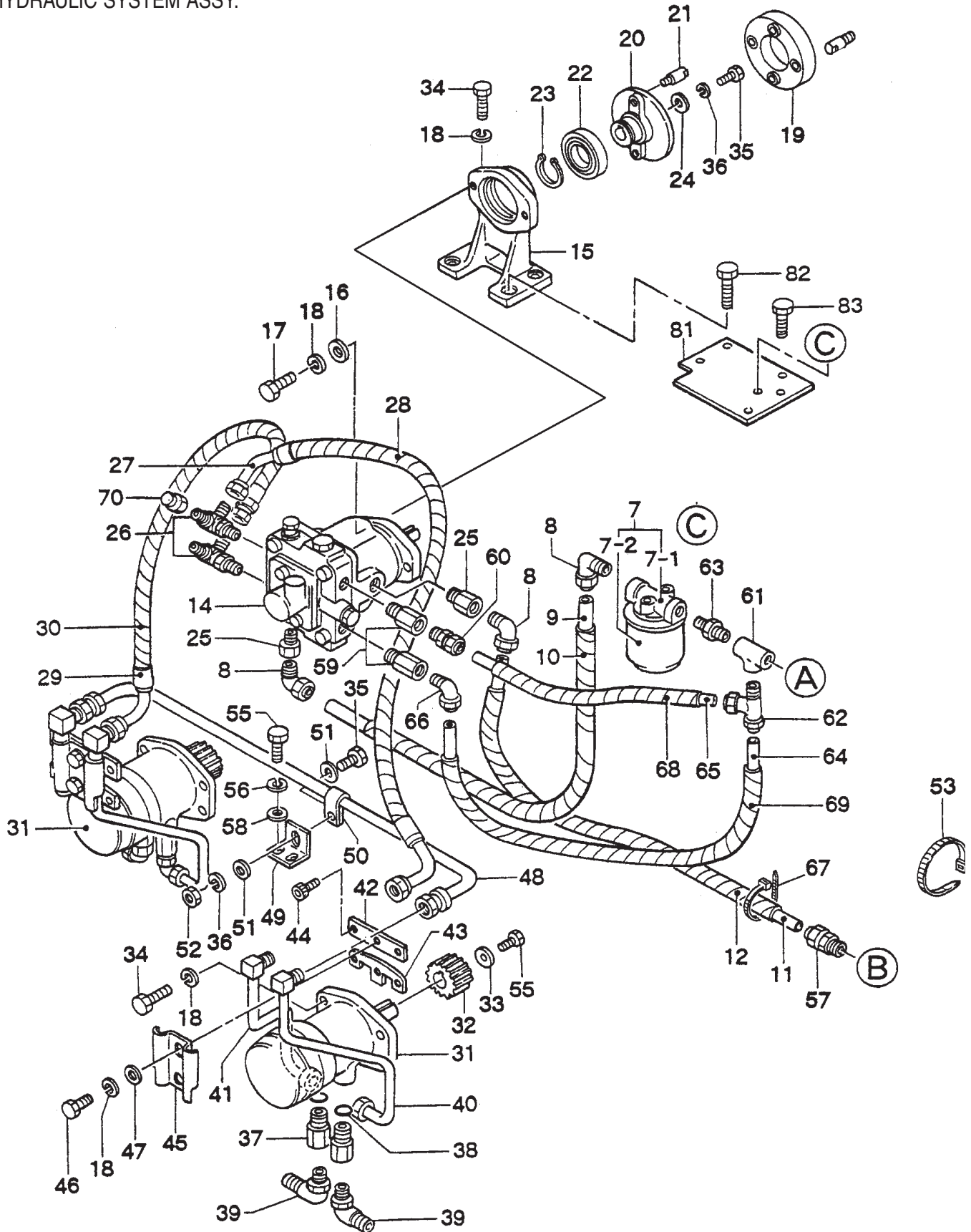

# MRH-800GS VIBRATION ROLLER — HYDRAULIC SYSTEM ASSY.

## HYDRAULIC SYSTEM ASSY.

<u>NO.</u>	<u>PART NO.</u>	<u>PART NAME</u>	<u>QTY.</u>	<u>REMARKS</u>
42	515447160	HOLDER, UPPER	2	
43	515447170	HOLDER, LOWER	2	
44	001520820	SOCKET HEAD BOLT 8X20 T	8	
45	515447140	COVER, PIPE	2	
46	012210020	BOLT 10X20 T .....	4	REPLACES 001221020
47	031110160	WASHER, FLAT M10 IN SYSTEM8		
48	515447150	PIPE, OM-B--OM-A	1	
49	515447300	STAY, PIPE	1	
50	607010040	CLAMP CLA-3200 (7D)	1	
51	952404470	WASHER, FLAT M6 .....	2	REPLACES 031106100
52	020106050	NUT M6 .....	1	REPLACES 020306050
53	507010110	CLAMP TC-200	5	
55	014208020	BOLT 8X20 T .....	4	REPLACES 001220820
56	030208200	WASHER, LOCK M8	2	
57	954001520	ADAPTER CIN-1/2XPT3/8	1	
58	031108160	WASHER, FLAT M8	2	
59	515335300	CHECK VALVE 7/16	2	
60	954001090	ADAPTER CIN-3/8-PT1/4	1	
61	954001010	JOINT PT3/8	1	
62	954001620	FITTING, TEE STIN3/8-PT3/8	1	
63	954001630	NIPPLE PT3/8	1	
64	954001650	TUBE 9.5D-7D-370	1	
65	954001640	TUBE 9.5D-7D-290	1	
66	954001100	ELBOW LIN-3/8-PT1/4	1	
67	454010020	CLAMP TC-100	12	
68	959021817	SPIRAL TUBE 6D-350L	1	
69	959021818	SPIRAL TUBE 6D-510L	1	
70	954001040	CAP PF1/4	2	
81	515335451	SPACER (PV10)	1	
82	0109051045	BOLT 10X40 T .....	4	REPLACES 001221040
83	012010030	BOLT 10X30 T .....	2	REPLACES 001221030
84	515447020	COUPLING PIN	2	

# MRH-800GS VIBRATION ROLLER — HYDRAULIC OIL TANK ASSY.

HYDRAULIC OIL TANK ASSY.

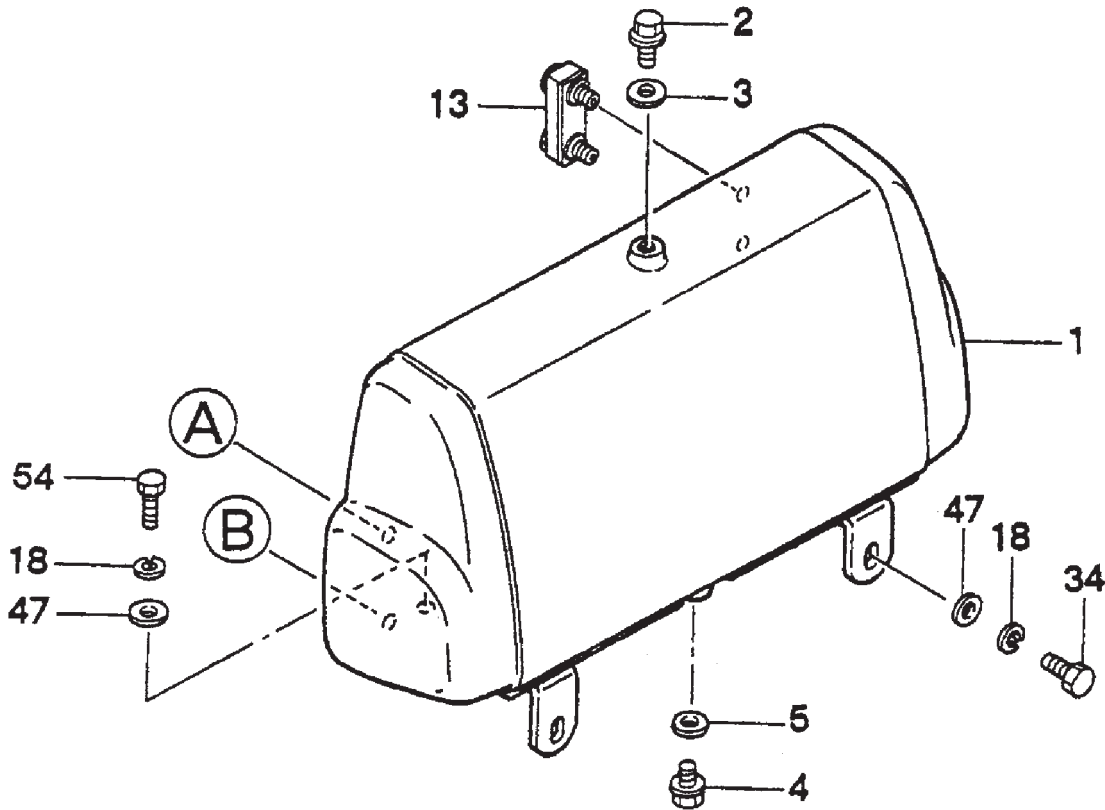

**(A)** NOTE:  
**(B)** SEE PAGE 52 FOR  
OIL TANK HOSE  
CONNECTIONS

# MRH-800GS VIBRATION ROLLER — HYDRAULIC OIL TANK ASSY.

## HYDRAULIC OIL TANK ASSY.

<u>NO.</u>	<u>PART NO.</u>	<u>PART NAME</u>	<u>QTY.</u>	<u>REMARKS</u>
1	515114221	OIL TANK, (GREEN)	1	
1	515010140	OIL TANK , (ORANGE)	1	
2	953405840	DRAIN PLUG M18 .....	1	..... REPLACES 953102781
3	953402930	COPPER PACKING 19X30X1	1	
4	953400270	PLUG 1/4X14 10L	1	
5	953405260	PACKING 1/4 (CU)	1	
13	959010120	LEVEL GAUGE/L =60	1	
18	030210250	WASHER, LOCK M10	22	
34	012210035	BOLT 10X35 T .....	14	..... REPLACE)S 001221035
47	031110160	WASHER, FLAT M10 IN SYSTEM	8	
54	0105091025	BOLT 10X25 T .....	2	..... REPLACES 001221025

# MRH-800GS VIBRATION ROLLER — ENGINE ASSY.

ENGINE (HONDA GX390) ASSY.

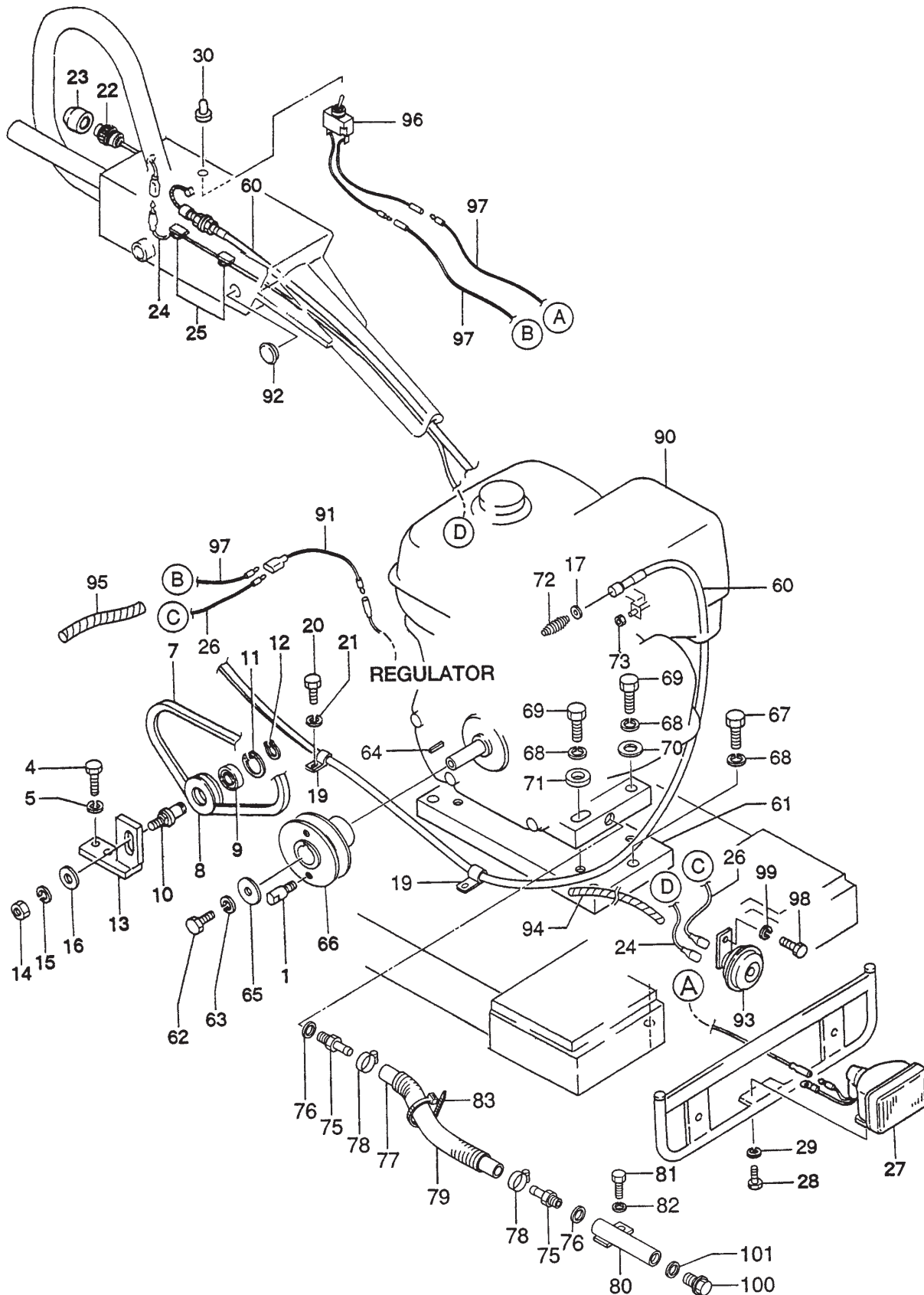

# MRH-800GS VIBRATION ROLLER — ENGINE ASSY.

ENGINE (HONDA GX390) ASSY.

<u>NO.</u>	<u>PART NO.</u>	<u>PART NAME</u>	<u>QTY.</u>	<u>REMARKS</u>
1	515447020	COUPLING PIN	2	
4	012010030	BOLT 10X30 T .....	2	REPLACES 001221030
5	030210250	WASHER, LOCK M10	2	
7	070503000	V-BELT 3V-300	1	
8	515447050	TIGHTENER PULLEY	1	
9	046006004	BEARING 6004DDU	1	
10	515447060	SHAFT TIGHTENER	1	
11	080100420	STOP RING R-42	1	
12	080200200	STOP RING S-20	1	
13	515334180	HOLDER, TIGHTENER	1	
14	020314110	NUT M14	1	
15	030214350	WASHER, LOCK M14	1	
16	031114260	WASHER, FLAT M14	1	
17	031104080	WASHER, FLAT M4	1	
19	607010040	CLAMP CLA-3200 (7D)	2	
20	011006010	BOLT 6X10 T .....	2	REPLACES 001220610
21	030206150	WASHER, LOCK M6	2	
22	955400800	SWITCH, HORN BUTTON ASSY	1	
23	955405980	COVER, HORN BUTTON	1	
24	515447320	READ CORD, HORN(WASHER, LOCK)	1	
25	955405710	WIRE CLAMP	2	
26	515449860	HARNESS (L1200)	1	
27	955200030	HEAD LAMP AY 12V-25W	1	
28	0105050616	BOLT 6X15 T .....	2	REPLACES 001220615
29	030206150	WASHER, LOCK M6	2	
30	304402600	CAP	1	
60	956100024	THROTTLE WIRE 2608-2700	1	
61	515337100	ENGINE SPACER (GX)	1	
62	011208025	BOLT 8X25 T .....	1	REPLACES 001220825
63	030208200	WASHER, LOCK M8	1	
64	951400520	KEY 7X7X33	1	
65	952400690	WASHER 9X35X4.5	1	
66	515338220	ENGINE PULLEY GX390	1	
67	0105051045	BOLT 10X40 T .....	4	REPLACES 001221040
68	030210250	WASHER, LOCK M10	8	
69	001421040	BOLT 10X40 T (B=14)	4	
70	031110160	WASHER, FLAT M10	2	
71	952404110	COLLAR 10225	2	
72	301010950	RETURN SPRING	1	
73	0030004000	NUT M4 .....	1	REPLACES 020304030
75	953406230	DRAIN JOINT	2	
76	953406240	DRAIN WASHER	2	

# MRH-800GS VIBRATION ROLLER — ENGINE ASSY. (CONT.)

ENGINE (HONDA GX390) ASSY. (CONT.)

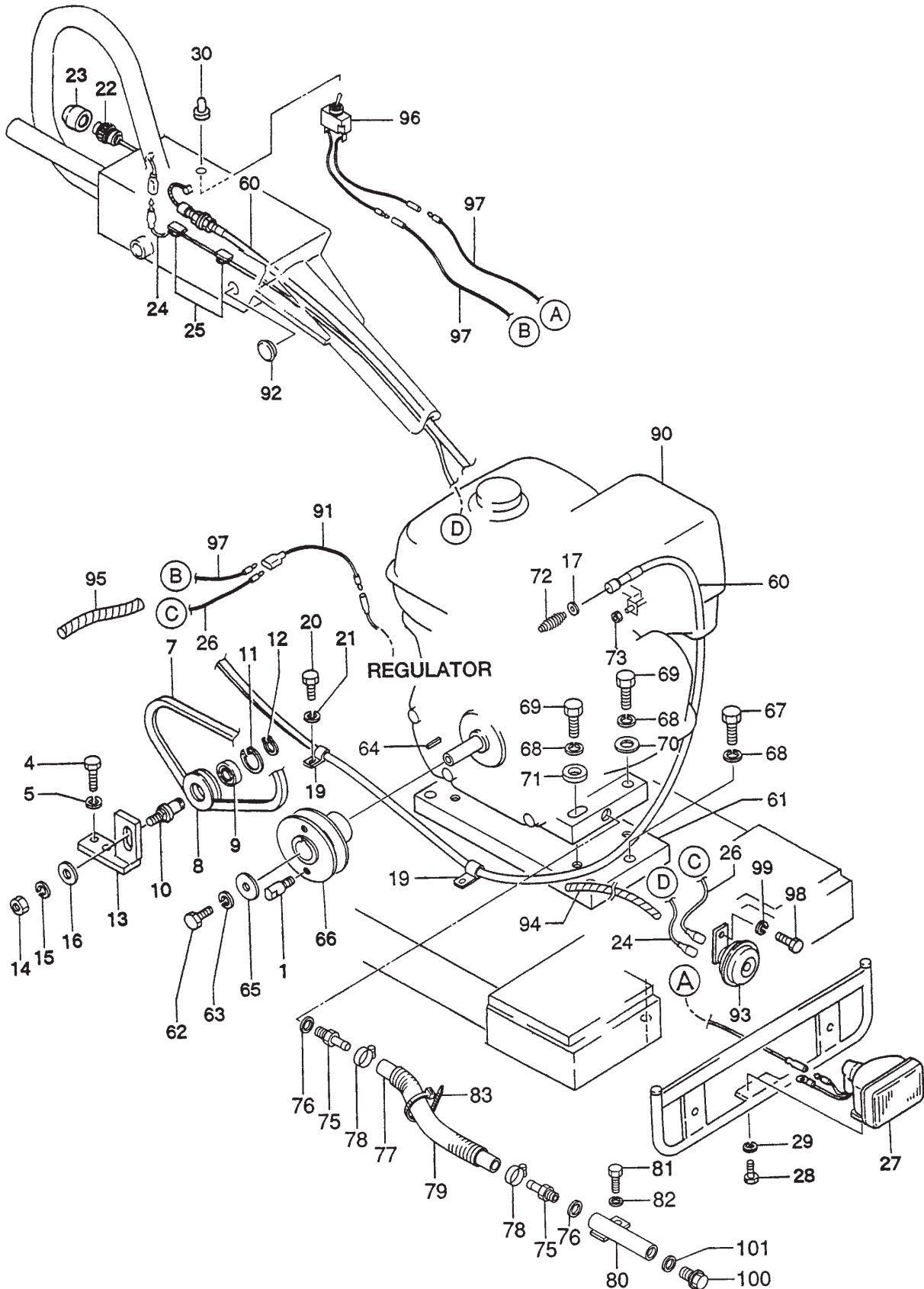

# MRH-800GS VIBRATION ROLLER — ENGINE ASSY. (CONT.)

## ENGINE (HONDA GX390) ASSY. (CONT.)

<u>NO.</u>	<u>PART NO.</u>	<u>PART NAME</u>	<u>QTY.</u>	<u>REMARKS</u>
77	954001760	OIL HOSE 9.5X19X380L	1	
78	954406080	CLIP, OIL HOSE (13-20)	2	
79	959026002	TUBE 20D-330L	1	
80	515450940	JOINT (M12-P1.5) 30L	1	
80	515450941	JOINT (M12-P1.5) 87L	1	
81	014208020	BOLT 8X20 T .....	1	REPLACES 001220820
82	030208200	WASHER, LOCK M8	1	
83	506010070	CLAMP TC-150	3	
90	912239006	ENGINE GX390K1SM32	1	
91	515451010	WIRE HARNESS	1	
92	515010070	GROMMET SG26A	1	
93	955300420	HORN AY (DC12V)	1	
94	959021812	SPIRAL TUBE 6D-800L	1	
95	959021811	SPIRAL TUBE 6D-400L	1	
96	515449910	SWITCH CP, S-1B W/CORD	1	
97	515449920	READ CORD (LAMP)	2	
98	011006010	BOLT 6X10 T .....	1	REPLACES 001220610
99	030206150	WASHER, LOCK M6	1	
100	90131883000	BOLT , DRAIN PLUG	1	
101	9410912000	WASHER DRAIN PLUG M12	1	

# MRH-800GS — ELECTRIC DEVICE

ELECTRIC DEVICE (HONDA GX390) ASSY.

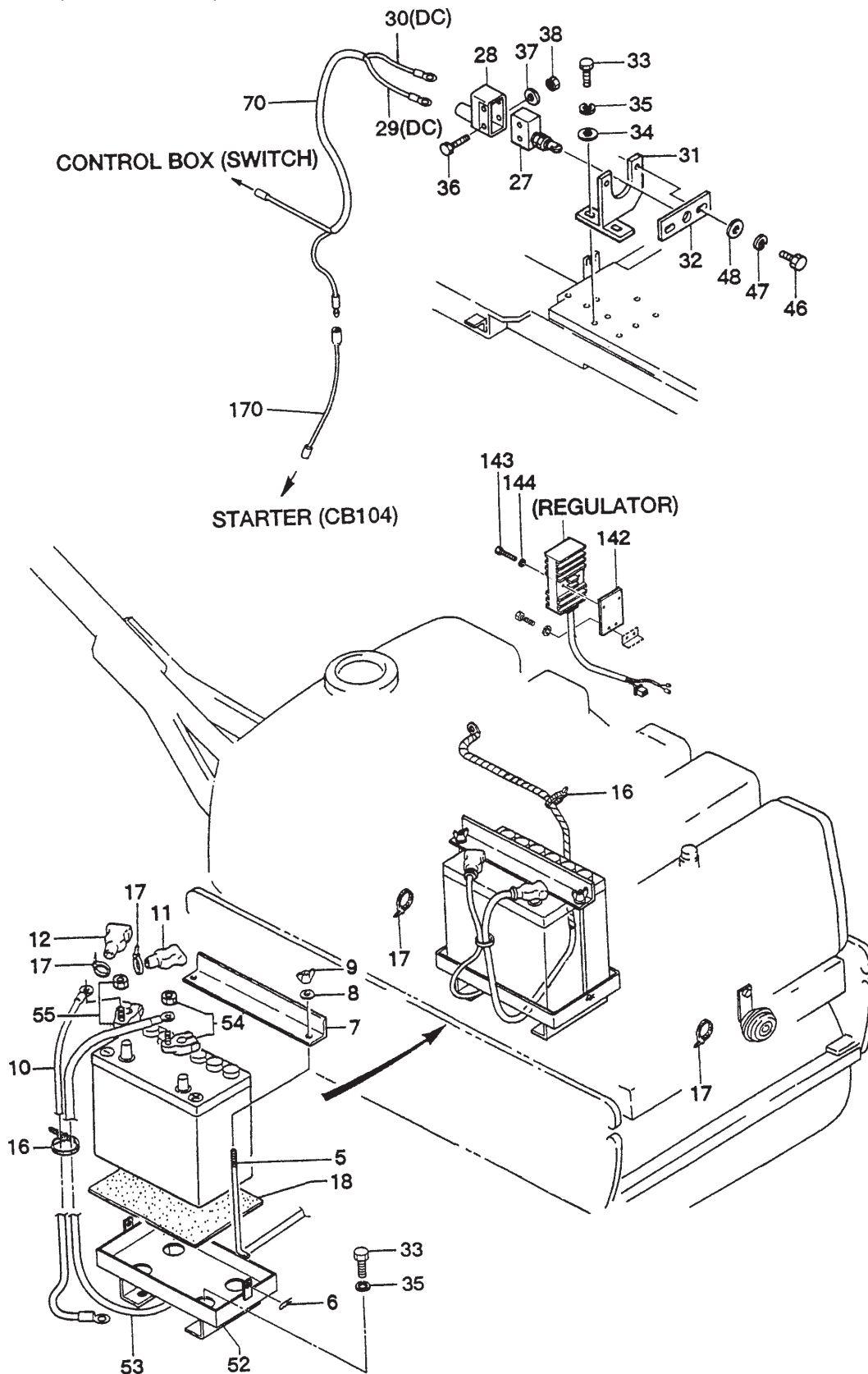

# MRH-800GS — ELECTRIC DEVICE

ELECTRIC DEVICE (HONDA GX390) ASSY.

<u>NO.</u>	<u>PART NO.</u>	<u>PART NAME</u>	<u>QTY.</u>	<u>REMARKS</u>
5	515448210	ROD, BATTERY	2	
6	607010080	COTTER PIN 6	2	
7	515447370	HOLDER, BATTERY -6,7	1	
8	952404470	WASHER, FLAT M6 .....	2	REPLACES 031106100
9	0037806000	WING NUT M6 .....	2	REPLACES 022410616
10	515447360	BATTERY CORD (-)	1	
11	055300500	TERMINAL COVER (+)	1	
12	955300510	TERMINAL COVER (-)	1	
16	507010110	CLAMP TC-200	3	
17	506010070	CLAMP TC-150	10	
18	601303150	RUBBER PLATE 160-226-1T	1	
27	955405910	MICRO-SWITCH ,700	1	
28	955405450	COVER, MICROSWITCH /MRX	1	
29	515449840	READ CORD 550L (COM-ST)	1	
30	515449850	READ CORD 550L (N.C-ST)	1	
31	515337110	HOLDER, MICRO-SWITCH	1	
32	515449230	PLATE, MICRO-SWITCH	1	
33	012210020	BOLT 10X20 T .....	6	REPLACES 001221020
34	031110160	WASHER, FLAT M10	2	
35	030210250	WASHER, LOCK M10	6	
36	001200430	BOLT 4X30	2	
37	031104080	WASHER, FLAT M4	2	
38	022710405	NYLON NUT M4	2	
46	0105050616	BOLT 6X15 T .....	2	REPLACES 001220615
47	030206150	WASHER, LOCK M6	2	
48	952404470	WASHER, FLAT M6 .....	2	REPLACES 031106100
52	516337580	BASE, BATTERY (55B24)	1	
53	515450740	BATTERY CORD (+) 1100L	1	
54	955300480	BATTERY TERMINAL (+)	1	
55	955300490	BATTERY TERMINAL (-)	1	
70	515453230	READ CORD (M-SWITCH) 550L-2	1	
142	515451000	BRACKET, REGULATOR	1	
143	011606025	BOLT 6X25 T .....	2	REPLACES 001220625
144	030206150	WASHER, LOCK M6	2	
170	515450930	WIRE HARNESS 300L	1	

# MRH-800GS VIBRATION ROLLER — CLUTCH (VIBRATION) ASSY.

CLUTCH (VIBRATION) ASSY.

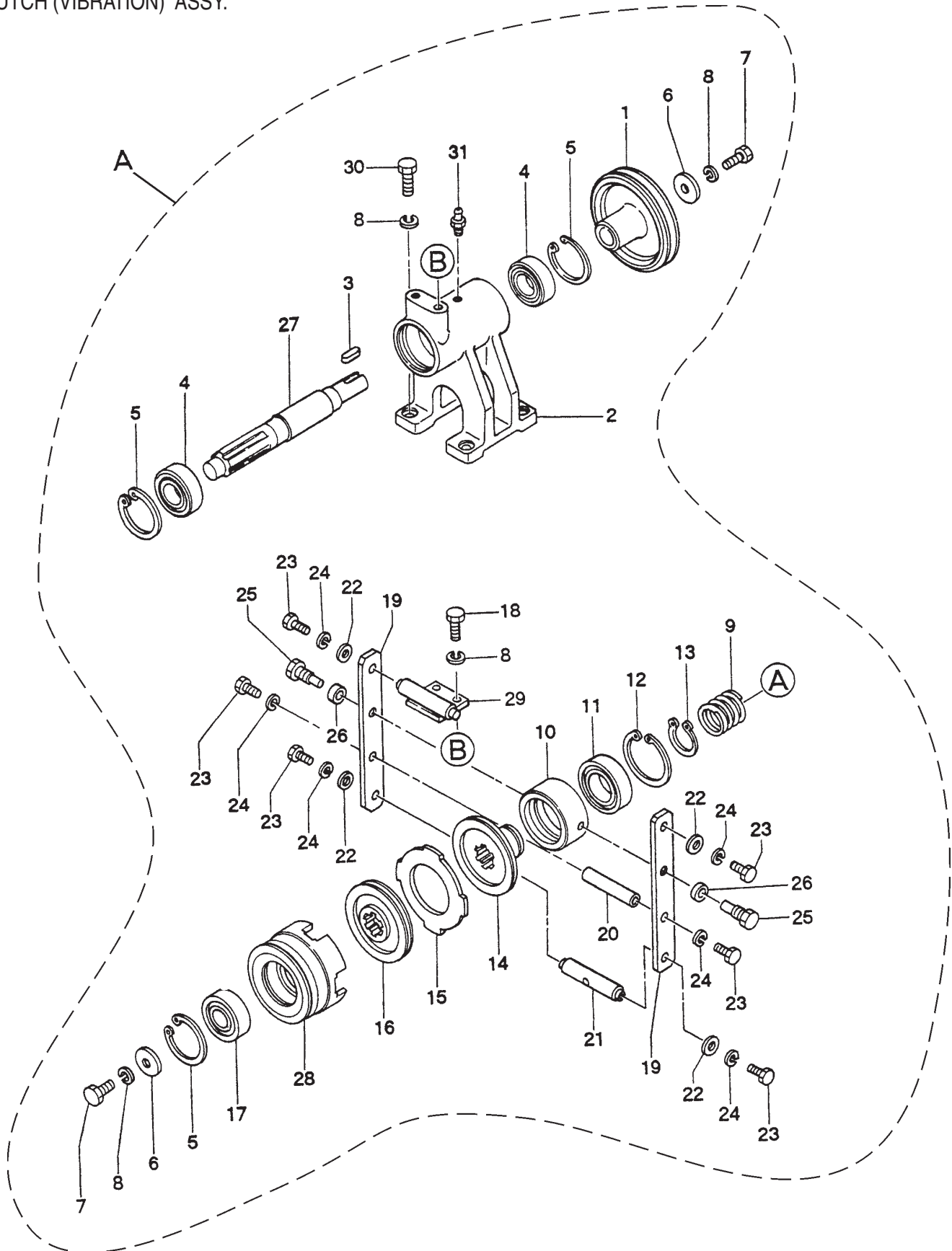

# MRH-800GS VIBRATION ROLLER — CLUTCH (VIBRATION) ASSY.

## CLUTCH (VIBRATION) ASSY.

<u>NO.</u>	<u>PART NO.</u>	<u>PART NAME</u>	<u>QTY.</u>	<u>REMARKS</u>
A	515910010	CLUTCH (VIB.) .....	1 .....	INCLUDES ITEMS W/*
1*	515447070	COUNTER PULLEY 130D-3V1	1	
2*	515212980	COUNTER BRACKET	1	
3*	951403020	KEY 7X7X26	1	
4*	043006206	BEARING 6206V	2	
5*	080100620	STOP RING R-62	3	
6*	952402470	WASHER 11366	2	
7*	012010030	BOLT 10X30 T .....	2 .....	REPLACES 001221030
8*	030210250	WASHER M10	8	
9*	509434770	CLUTCH SPRING	1	
10*	509434780	RELEASE COLLAR 62X78X40	1	
11*	044006008	BEARING 6008VV	1	
12*	080100680	STOP RING R-68	1	
13*	080200400	STOP RING S-40	1	
14*	515447080	PRESSURE PLATE	1	
15*	515447090	INSIDE PLATE	1	
16*	515447100	DISC PLATE	1	
17*	044006305	BEARING 6305VV	1	
18*	012210020	BOLT 10X20 T .....	2 .....	REPLACES 001221020
19*	509324690	RELEASE FORK	2	
20*	509434850	STUD BAR 18D X80L	1	
21*	509434860	LOCK, WIRE	1	
22*	952401690	WASHER 7173	4	
23*	010505506	BOLT 6X15 T .....	6 .....	REPLACES 001220615
24*	030206150	WASHER M6	6	
25*	509434870	FORK PIN	2	
26*	509434880	COLLAR, FORK PIN 12.5X20X5	2	
27*	515334200	COUNTER SHAFT	1	
28*	515334210	CLUTCH PULLEY 113D-A2	1	
29*	409434840	BRACKET, RELEASE FORK	1	
30*	012010030	BOLT 10X30 T .....	4 .....	REPLACES 001221030
31*	505015060	GREASE FITTING A-PT1/8 .....	1 .....	REPLACES 301010100

# MRH-800GS VIBRATION ROLLER — VIBRATOR ASSY.

VIBRATOR ASSY.

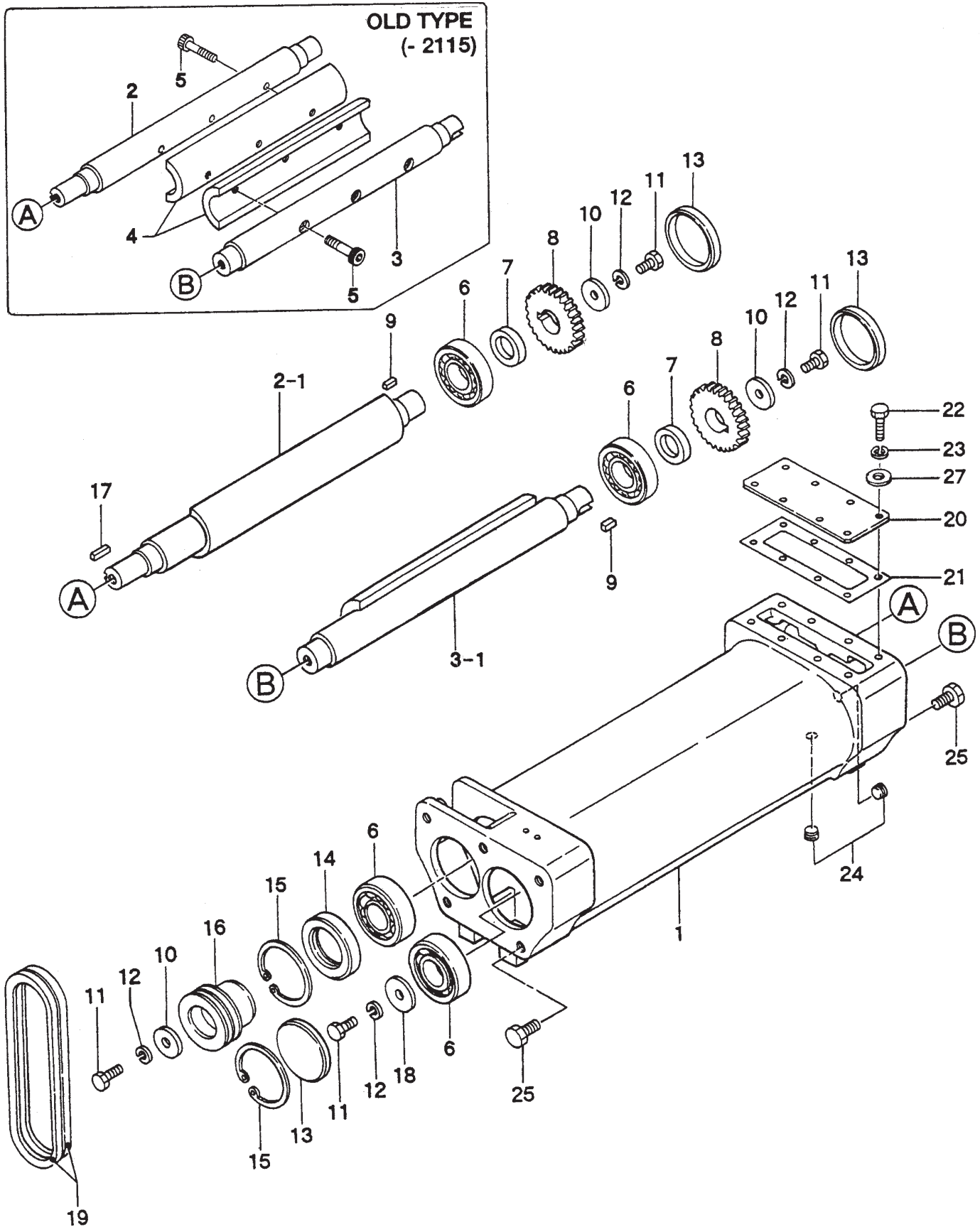

# MRH-800GS VIBRATION ROLLER — VIBRATOR ASSY.

## VIBRATOR ASSY.

<u>NO.</u>	<u>PART NO.</u>	<u>PART NAME</u>	<u>QTY.</u>	<u>REMARKS</u>
1	515113090	VIBRATING CASE	1	
2	515334110	ROTARY SHAFT, DRIVE .....	1	- 215 #2
2-1	515334111	ROTARY SHAFT, DRIVE 00 .....	1	F2116- *2
3	515334120	ROTARY SHAFT, DRIVEN .....	1	- 2115 #2
3-1	515334121	ROTARY SHAFT, DRIVEN .....	1	F2116-*2
4	515334130	ECCENTRIC ROTATOR .....	2	- 2115 #2
5	001521252	SOCKET HEAD BOLT 12X60 T .....	6	- 2115 #2
6	040406308	BEARING 6308C4	4	
7	501011020	GEAR SPACER	2	
8	501011000	GEAR 38	2	
9	951400080	KEY 10X8X17 .....	2	REPLACES 951400081
10	952400900	WASHER 13446	3	
11	012212030	BOLT 12X30 T .....	4	REPLACES 001221230
12	030212300	WASHER, LOCK M12	4	
13	953405570	SEAL CAP SC- 90-10	3	
14	060206020	OIL SEAL SC- 659013	1	
15	080100900	STOP RING R-90	2	
16	515447040	PULLEY 86D-A2	1	
17	951400090	KEY 10X8X33	1	
18	952401590	WASHER 13X50X6	1	
19	070100381	V-BELT A- 38 RED	2	
20	515334140	COVER, GEAR	1	
21	515334150	PACKING, COVER	1	
22	014208020	BOLT 8X20 T .....	8	REPLACES 001220820
23	030208200	WASHER, LOCK M8	8	
24	894230	PLUG PT1/4 .....	2	REPLACES 505015380
25	001221430	BOLT 14X30 T	10	
25	001221425	BOLT 14X25 T .....	10	F2116-
27	031108160	WASHER, FLAT M8	8	

# MRH-800GS VIBRATION ROLLER — UPPER CONTROL ARM ASSY.

UPPER CONTROL ARM ASSY.

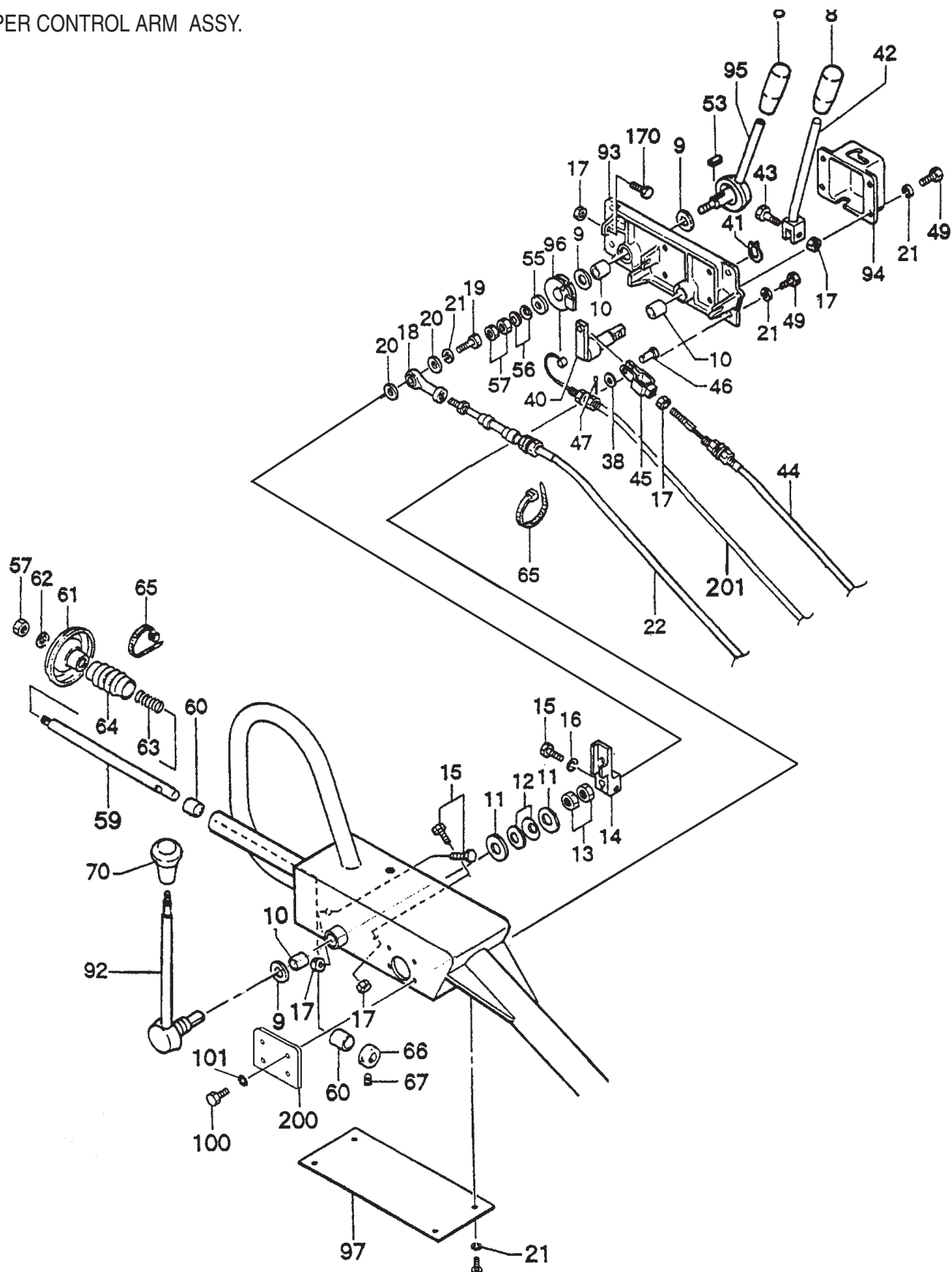

# MRH-800GS VIBRATION ROLLER — UPPER CONTROL ARM ASSY.

## UPPER CONTROL ARM ASSY.

<u>NO.</u>	<u>PART NO.</u>	<u>PART NAME</u>	<u>QTY.</u>	<u>REMARKS</u>
8	959403840	BAR GRIP, I.D. 12MM	2	
9	953402930	COPPER PACKING 19X30X1	3	
10	509010130	BUSHING MB1825DU	3	
11	952405700	WASHER 19X49X0.6	2	
12	952403690	CONICAL SPRING WASHER M18	2	
13	020418110	NUT M18, H=11	2	
14	515447410	LEVER JOINT, TRAVELLING	1	
15	011208030	BOLT 8X30 T .....	3	REPLACES 001220830
16	030208200	WASHER, LOCK M8	3	
17	02108060	NUT M8 .....	5	REPLACES 020308060
18	501011162	ROD END PR6-209	2	
19	011206020	BOLT 6X20 T .....	1	REPLACES 001220620
20	952404470	WASHER 6.5X15X1.6	4	
21	030206150	WASHER, LOCK M6	14	
22	515334230	CABLE	1	
40	509326970	SHAFT, LEVER	1	
41	080200180	STOP RING S-18	1	
42	509436911	LEVER, VIB.	1	
43	011208035	BOLT 8X35 T .....	1	REPLACES 001220835
44	515334240	CABLE ASSY., VIBRATION	1	
45	959404760	CLEVIS 8D X44	1	
46	959404370	PIN 8X22	1	
47	025910080	SNAP PIN /SSP-8	1	
49	0105050616	BOLT 6X15 T .....	12	REPLACES 001220615



# MRH-800GS VIBRATION ROLLER — UPPER CONTROL ARM ASSY. (CONT.)

## UPPER CONTROL ARM ASSY. (CONT.)

<u>NO.</u>	<u>PART NO.</u>	<u>PART NAME</u>	<u>QTY.</u>	<u>REMARKS</u>
53	951401431	KEY 5X5X8	1	
55	952404790	WASHER 13306	1	
56	032212250	CONICAL SPRING WASHER M12	2	
57	0039312000	NUT M12 .....	3	REPLACES 020312100
59	515334820	ROD	1	
60	509010140	BUSHING MB1625DU	2	
61	515447720	DISC PLATE, DEAD-MAN	1	
62	030212300	WASHER, LOCK M12	1	
63	509436980	SPRING, DEAD-MAN	1	
64	509436990	PROTECTOR, DEAD-MAN	1	
65	507010110	CLAMP TC-200	2	
66	509436960	ROD STOPPER, DEAD-MAN	1	
67	014206010	SOCKET HEAD SCREW 6X6 T .....	2	REPLACES 099206006
70	959405920	KNOB 44D-78L	1	
92	515336490	TRAVELLING LEVER 260L	1	
93	515212950	LEVER SUPPORT, VIB. E/G	1	
94	515334460	LEVER COVER, VIB.	1	
95	515336500	LEVER, E/G 133L	1	
96	509326320	GUIDE, WIRE (E/G)	1	
97	509436950	COVER, HANDLE BOX	1	
100	011006010	BOLT 6X10 T .....	4	REPLACES 001220610
101	030206150	WASHER, LOCK M6	4	
170	011208030	BOLT 8X30 T .....	1	REPLACES 001220830 FOR L100
200	517452260	COVER (FOR CRANK START) MRH	1	
201	956100024	THROTTLE WIRE	1	

# MRH-800GS VIBRATION ROLLER — LOWER CONTROL ARM ASSY.

LOWER CONTROL ARM ASSY.

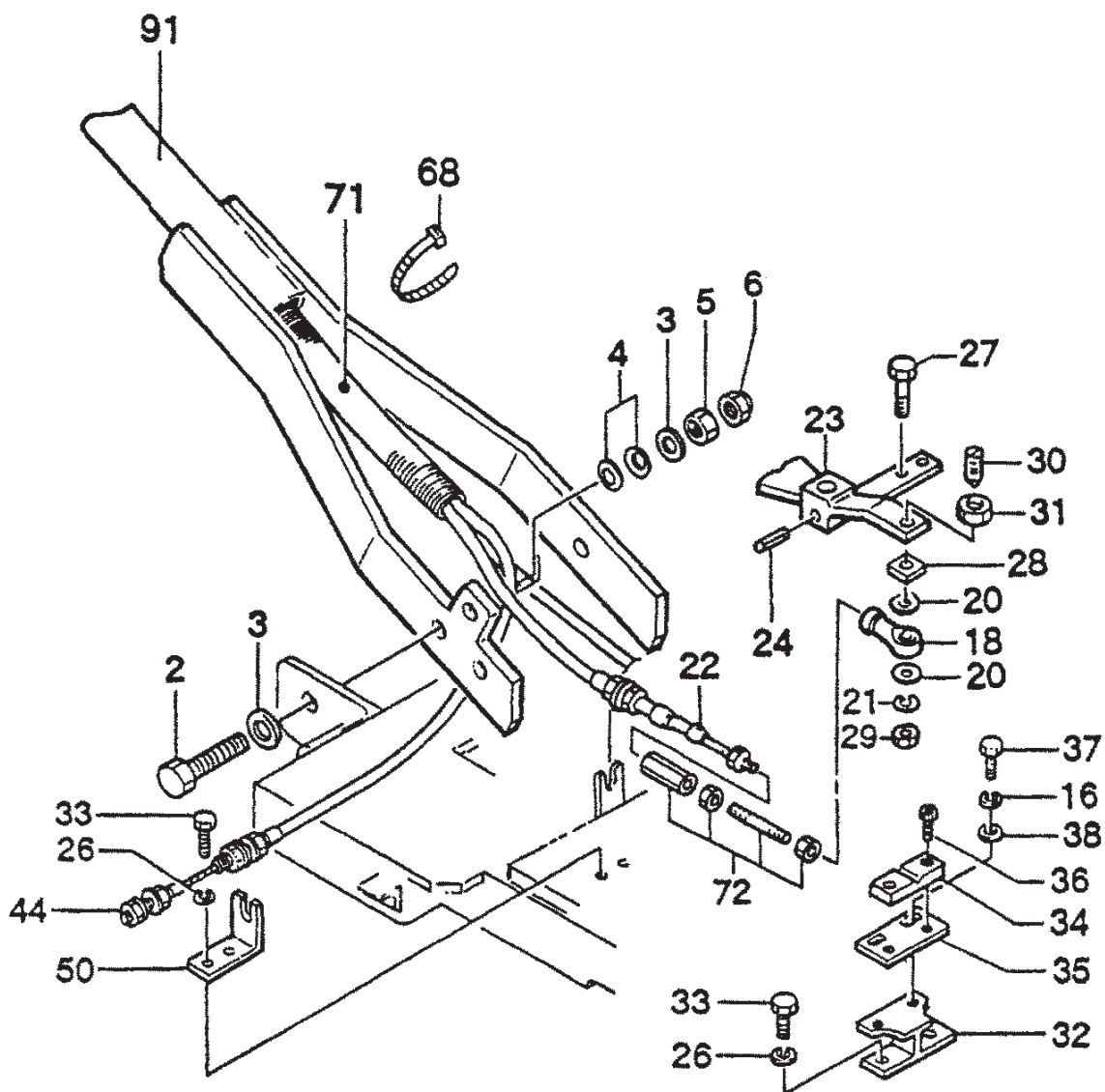

# MRH-800GS VIBRATION ROLLER — LOWER CONTROL ARM ASSY.

## LOWER CONTROL ARM ASSY.

<u>NO.</u>	<u>PART NO.</u>	<u>PART NAME</u>	<u>QTY.</u>	<u>REMARKS</u>
2	001222055	BOLT 20X75 T	2	
3	031120320	WASHER, FLAT M20	1	
4	032220450	CONICAL SPRING WASHER M20	4	
5	020320160	NUT M20	2	
6	022522017	LOCK NUT U-M20	2	
16	030208200	WASHER, LOCK M8	3	
18	501011162	ROD END PR6-209	2	
20	952404470	WASHER 6.5X15X1.6	4	
21	030206150	WASHER, LOCK M6	14	
22	515334230	CABLE AY 33050E1700	1	
23	515335780	LEVER (PV10), E- START	1	
24	025406032	SPRING PIN 6X32	1	
26	030210250	WASHER, LOCK M10	4	
27	001220635	BOLT 6X35 T	1	
28	515450560	SPACER (PV10)	1	
29	022710607	NYLON NUT M6	1	
30	505015150	SPRING PLUNGER	1	
31	020116130	NUT M16, H=10 .....	1	REPLACES 020416100
32	509321160	GUIDE HOLDER	1	
33	012210020	BOLT 10X20 T .....	4	REPLACES 00122120
34	515448170	GUIDE	1	
35	515448180	SLIDE PLATE	1	
36	014206015	SOCKET HEAD BOLT 6X15 T .....	2	REPLACES 001520615
37	011008015	BOLT 8X15 T .....	2	REPLACES 001220815
38	031108160	WASHER, FLAT M8	3	
44	515334240	CABLE AY (VIB.)	1	
50	515447180	CABLE SUPPORT, VIB.	1	
68	506010070	CLAMP TC-150	8	
71	959021911	TUBE 25D-850L	1	
72	501910010	TURN BUCKLE ASS'Y.	1	
91	515115910	HANDLE	1	

# HONDA GX-390K1SM32 — CYLINDER HEAD ASSY.

CYLINDER HEAD ASSY.

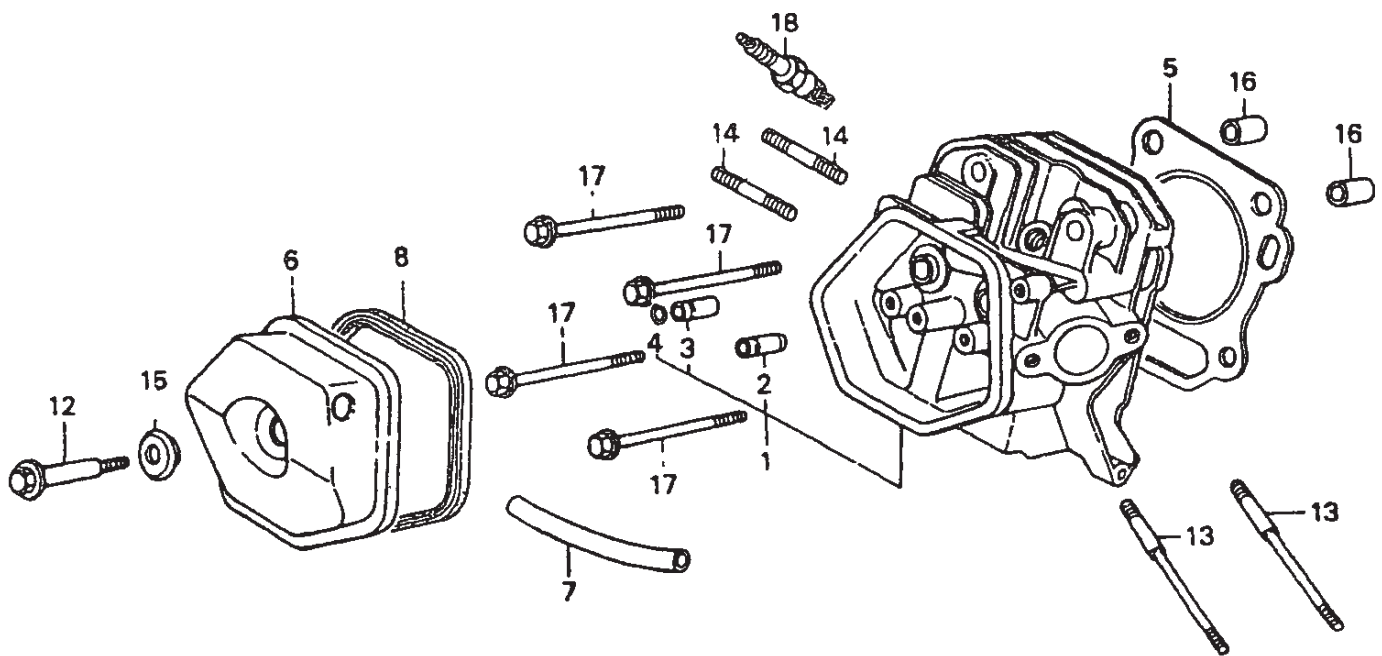

# HONDA GX-390K1SM32 — CYLINDER HEAD ASSY.

## CYLINDER HEAD ASSY.

<u>NO.</u>	<u>PART NO.</u>	<u>PART NAME</u>	<u>QTY.</u>	<u>REMARKS</u>
1	12200ZF6W00	HEAD COMP., CYLINDER .....	1 .....	INCLUDES ITEMS W/*
2*	12204ZE2306	GUIDE, IN. VALVE (OVERSIZE)	1	
3*	12205ZE2305	GUIDE, EX. VALVE (OVERSIZE)	1	
4*	12216ZE2300	CLIP, VALVE GUIDE	1	
5	12251ZF6W00	GASKET, CYLINDER HEAD	1	
6	12310ZE2020	COVER COMP., HEAD	1	
7	950051110530	TUBE, 11X105	1	
8	12391ZE2020	PACKING, HEAD COVER	1	
12	90014ZE2000	BOLT, HEAD COVER	1	
13	90042ZE8000	BOLT, STUD 8X31.5	2	
14	92900080320E	BOLT, STUD 8X32	2	
15	90441ZE2010	WASHER COMP., HEAD COVER	1	
16	9430112200	PIN, DOWEL 12X20	2	
17	957251008000	BOLT, FLANGE 10X80	4	
18	9807956846	SPARK PLUG, NKG	1	

# HONDA GX-390K1SM32 — CYLINDER BARREL ASSY.

CYLINDER BARREL ASSY.

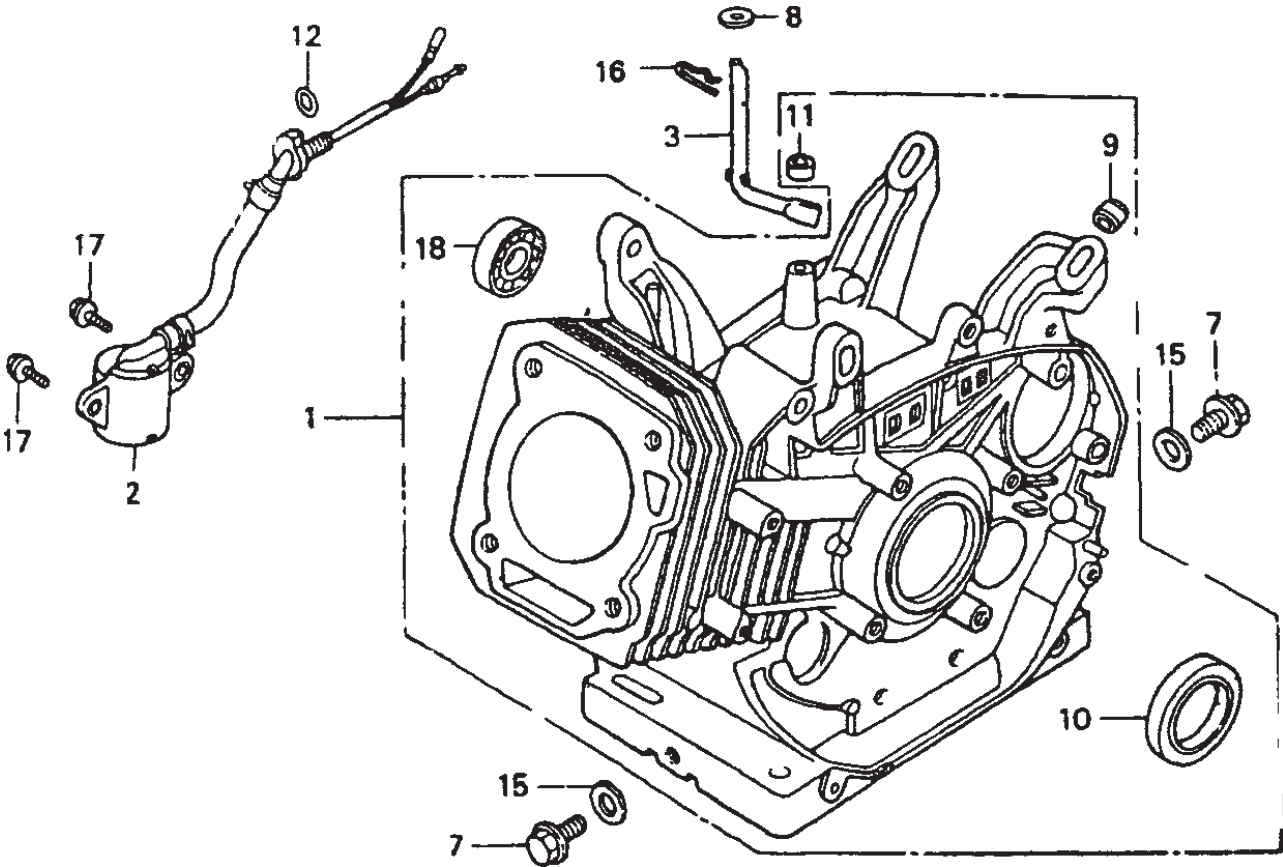

# HONDA GX-390K1SM32 — CYLINDER BARREL ASSY.

## CYLINDER BARREL ASSY.

<u>NO.</u>	<u>PART NO.</u>	<u>PART NAME</u>	<u>QTY.</u>	<u>REMARKS</u>
1	12000ZF6415	BARREL ASSY., CYLINDER .....	1 .....	INCLUDES ITEMS W/*
2	15510ZE2043	SWITCH ASSY, OIL LEVEL	1	
3	16541ZE010	SHAFT, GOVERNOR ARM	1	
7	90131883000	BOLT, DRAIN PLUG	2	
8	90446KE1000	WASHER, 8.2X17X0.8	1	
9*	90801ZE2003	PLUG, SEALING	1	
10*	91201ZE3004	OIL SEAL 35X52X8	1	
11*	91203952771	OIL SEAL 8X14X5	1	
12	91353671004	O-RING 14 MM	1	
15	9410912000	WASHER, DRAIN PLUG M12	2	
16	9425110000	PIN, LOCK 10MM	1	
17	957010601200	FLANGE BOLT 6x12	2	
18*	961006202000	BEARING, RADIAL BALL 6202	1	

# HONDA GX-390K1SM32 — CRANKCASE COVER ASSY.

CRANKCASE COVER ASSY.

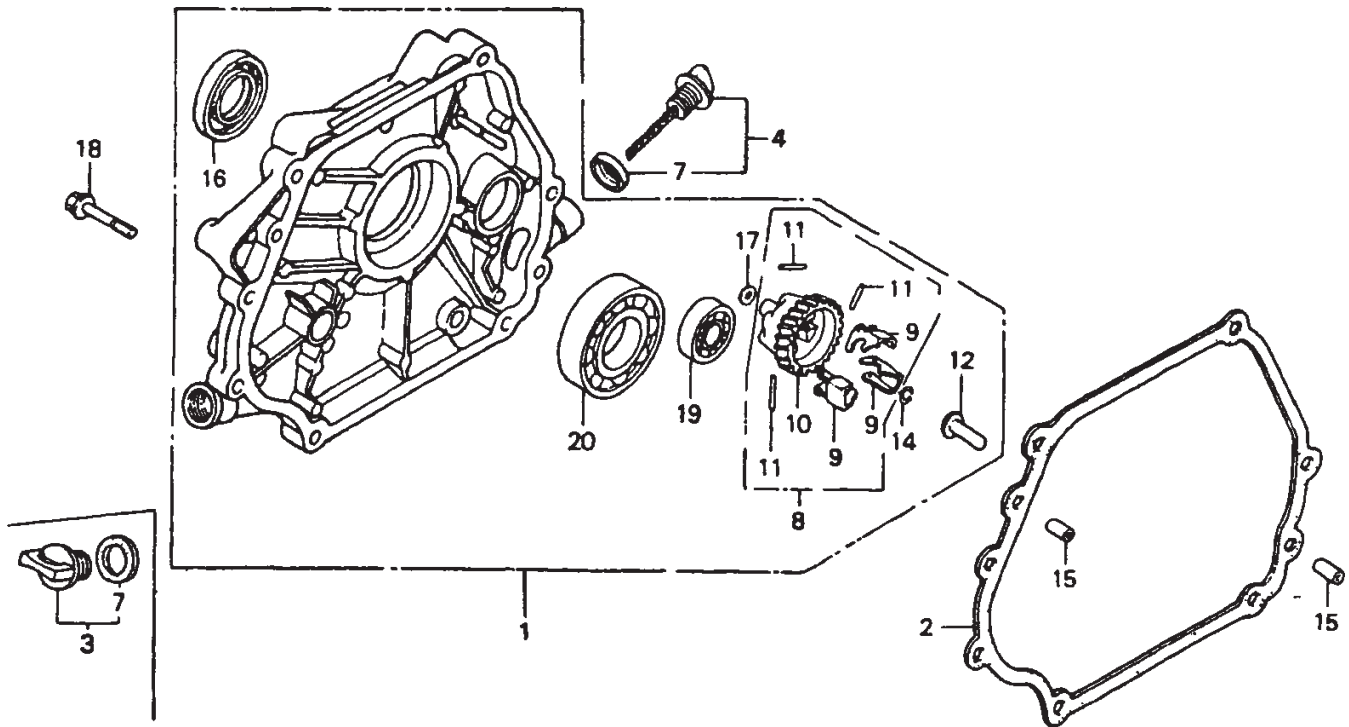

# HONDA GX-390K1SM32 — CRANKCASE COVER ASSY.

## CRANKCASE COVER ASSY.

<u>NO.</u>	<u>PART NO.</u>	<u>PART NAME</u>	<u>QTY.</u>	<u>REMARKS</u>
1	11300ZE3020	COVER ASSY., CRANKCASE .....	1 .....	INCLUDES ITEMS W/
2	11381ZE3800	PACKING, CASE COVER	1	
3	15600ZG4003	OIL PLUG ASSY. ....	1 .....	INCLUDES ITEMS W/#
4	15600735003	CAP ASSY., OIL FILLER .....	1 .....	INCLUDES ITEMS W/+
7+	15625ZE1003	PACKING, OIL FILLER CAP	2	
8#	16510ZE3000	GOVERNOR ASSY. ....	1 .....	INCLUDES ITEMS W/*
9*#	16511ZE8000	WEIGHT, GOVERNOR	3	
10*#	16512ZE3000	HOLDER, GOVERNOR WGHT.	1	
11*#	16513ZE2000	PIN, GOVERNOR WEIGHT	3	
12#	16531ZE2000	SLIDER, GOVERNOR	1	
14#	90602ZE1000	CLIP, GOVERNOR HOLDER	1	
15	90701HC4000	PIN, DOWEL 8X12	2	
16#	91201ZE3004	OIL SEAL 35X52X8	1	
17#	9410106800	PLAIN WASHER 6MM	1	
18	957010804000	BOLT, FLANGE 8X40	7	
19#	961006202000	BEARING, RADIAL BALL 6202	1	
20#	961006207000	BEARING, RADIAL	1	

# HONDA GX-390K1SM32 — CRANKSHAFT ASSY.

CRANKSHAFT ASSY.

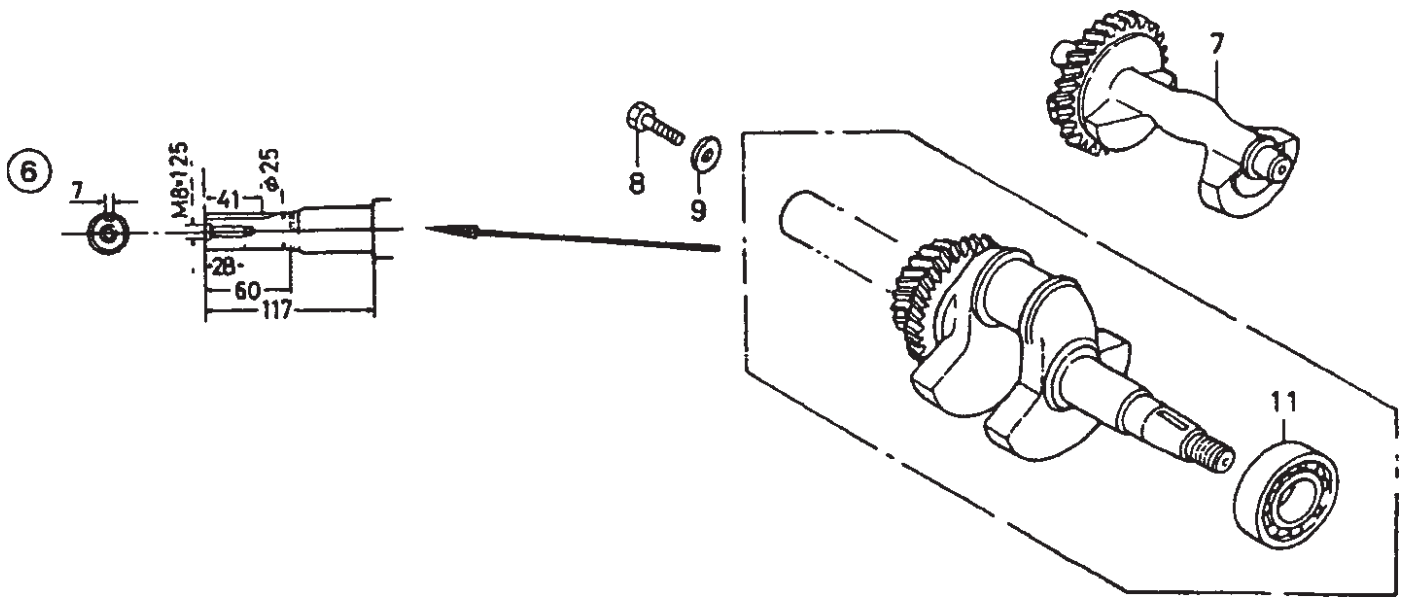

# HONDA GX-390K1SM32 — CRANKSHAFT ASSY.

## CRANKSHAFT ASSY.

<u>NO.</u>	<u>PART NO.</u>	<u>PART NAME</u>	<u>QTY.</u>	<u>REMARKS</u>
6	13310ZF6W70	CRANKSHAFT COMP. ....	1 .....	INCLUDES ITEMS W/*
7	13351ZE3010	WEIGHT, BALANCER	1	
8	92101080250A	BOLT 8X25	1	
9	90534706010	WASHER, LOCK 8MM	1	
11*	91001ZF6003	BEARING, RADIAL BALL 6207S	1	

# HONDA GX-390K1SM32 — PISTON ASSY.

PISTON ASSY.

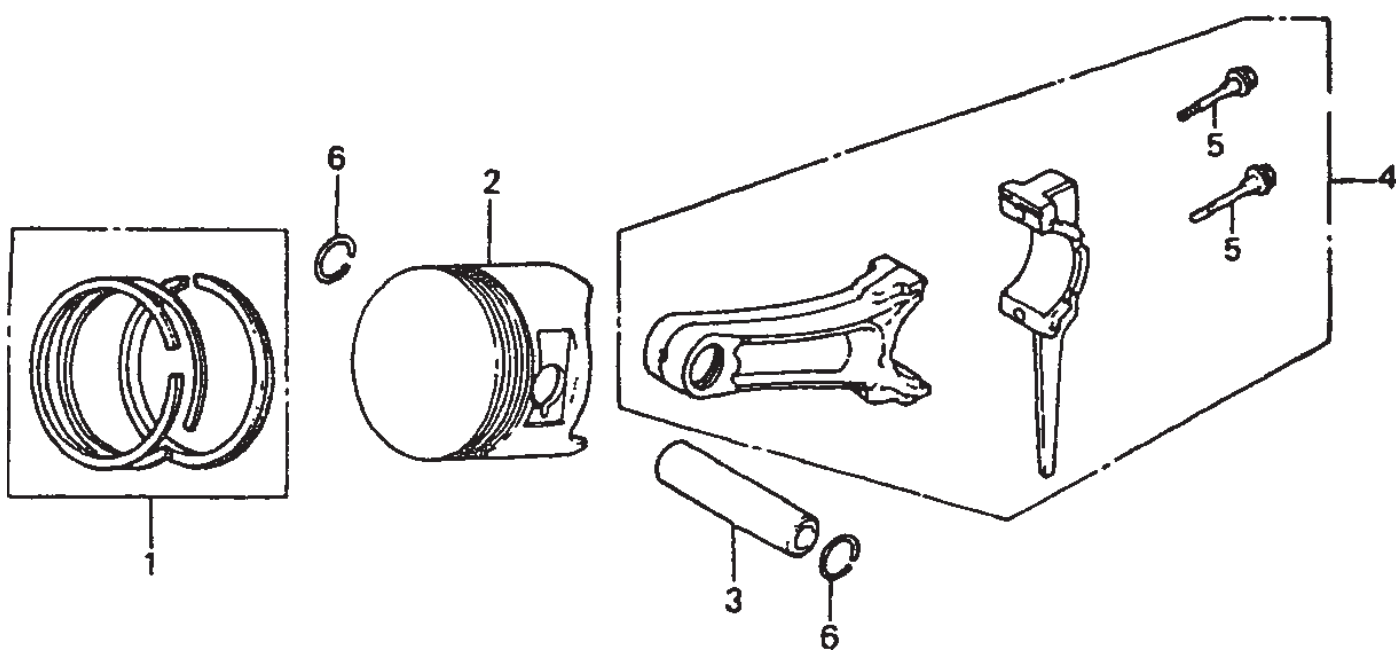

## HONDA GX-390K1SM32 — PISTON ASSY.

### PISTON ASSY.

<u>NO.</u>	<u>PART NO.</u>	<u>PART NAME</u>	<u>QTY.</u>	<u>REMARKS</u>
1	13010ZF6003	RING SET, PISTON (STD.)	1	
1	13011ZF6003	RING SET, PISTON (0.25)	1	
1	13012ZF6003	RING SET, PISTON (0.50)	1	
1	13013ZF6003	RING SET, PISTON (0.75)	1	
2	13101ZF6W00	PISTON (STD.)	1	
2	13102ZF6W00	PISTON (0.25)	1	
2	13103ZF6W00	PISTON (0.50)	1	
2	13104ZF6W00	PISTON (0.75)	1	
3	13111ZF6W00	PIN PISTON	1	
4	13200ZE3010	ROD ASSY., CONNECT. STD. ....	1	INCLUDES ITEMS W/*
4	13200ZE3315	ROD ASSY., CONNECT. 0.25 .....	1	INCLUDES ITEMS W/*
5*	90001ZE8000	BOLT, CONNECTING ROD	2	
6	90601ZE3000	CLIP,PISTON PIN 20MM	2	

# HONDA GX-390K1SM32 — CAMSHAFT ASSY.

CAMSHAFT ASSY.

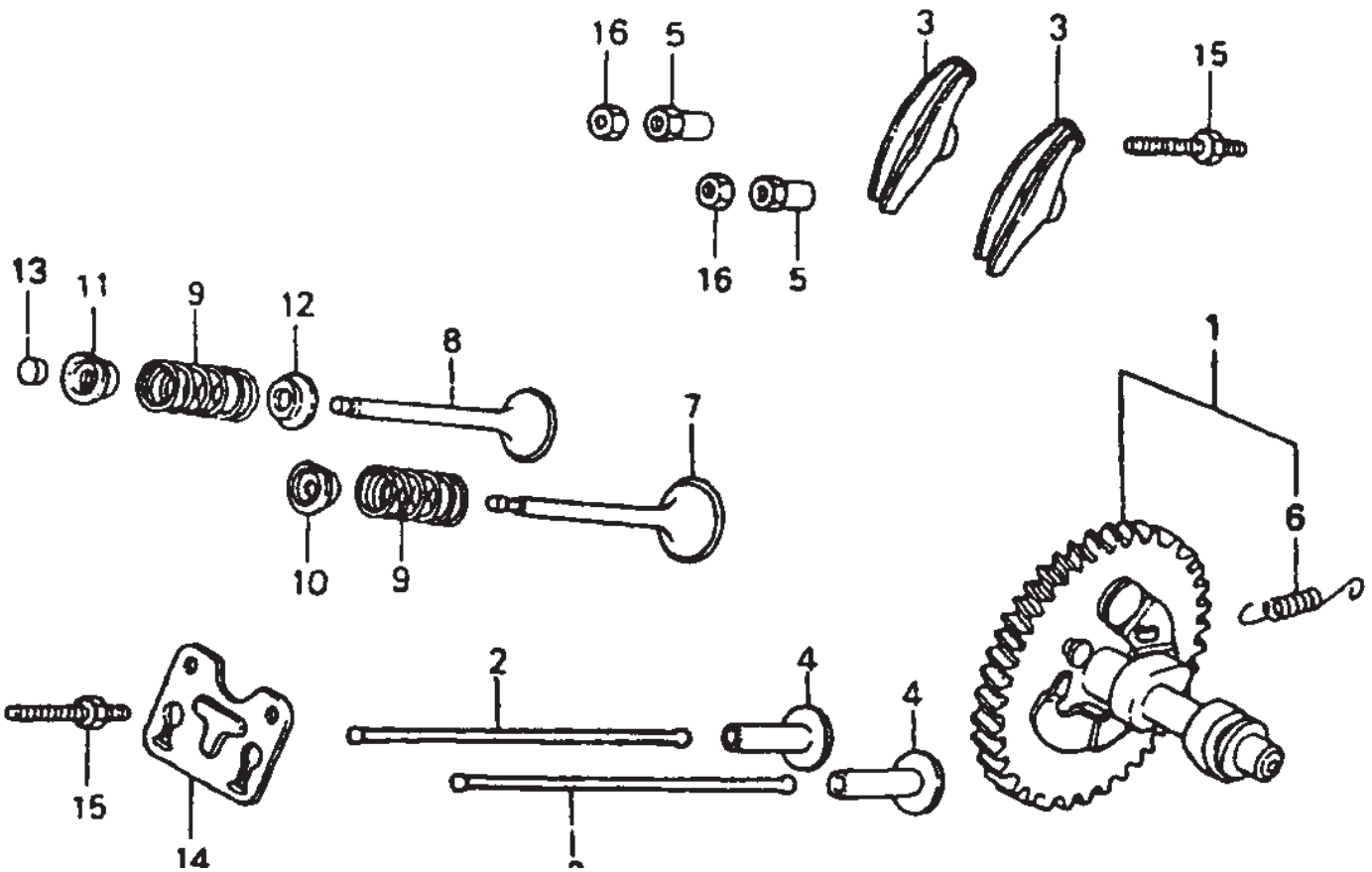

## HONDA GX-390K1SM32 — CAMSHAFT ASSY.

### CAMSHAFT ASSY.

<u>NO.</u>	<u>PART NO.</u>	<u>PART NAME</u>	<u>QTY.</u>	<u>REMARKS</u>
1	14100ZF6W01	CAMSHAFT ASSY. ....	1	INCLUDES ITEMS W/*
2	14410ZE3013	ROD, PUSH	2	
3	14431ZE2010	ARM, VALVE ROCKER	2	
4	14441ZE2000	LIFTER, VALVE	2	
5	14451ZE1013	PIVOT, ROCKER ARM	2	
6*	14568ZE1000	SPRING, WEIGHT RETURN	1	
7	14711ZE3000	VALVE, IN.	1	
8	14721ZE3000	VALVE, EX.	1	
9	14751ZE2003	SPRING, VALVE	2	
10	14771ZE2000	RETAINER, IN. VALVE SPRING	1	
11	14773ZE2000	RETAINER, EX. VALVE SPRING	1	
12	14775ZE2010	SEAT, VALVE SPRING	1	
13	14781ZE2000	ROTATOR, VALVE	1	
14	14791ZE2010	PLATE, PUSH ROD GUIDE	1	
15	90012ZE0010	PIBOT BOLT 8MM	2	
16	90206ZE1000	NUT, PIBOT ADJUSTING	2	

# HONDA GX-390K1SM32 — RECOIL STARTER ASSY.

RECOIL STARTER ASSY.

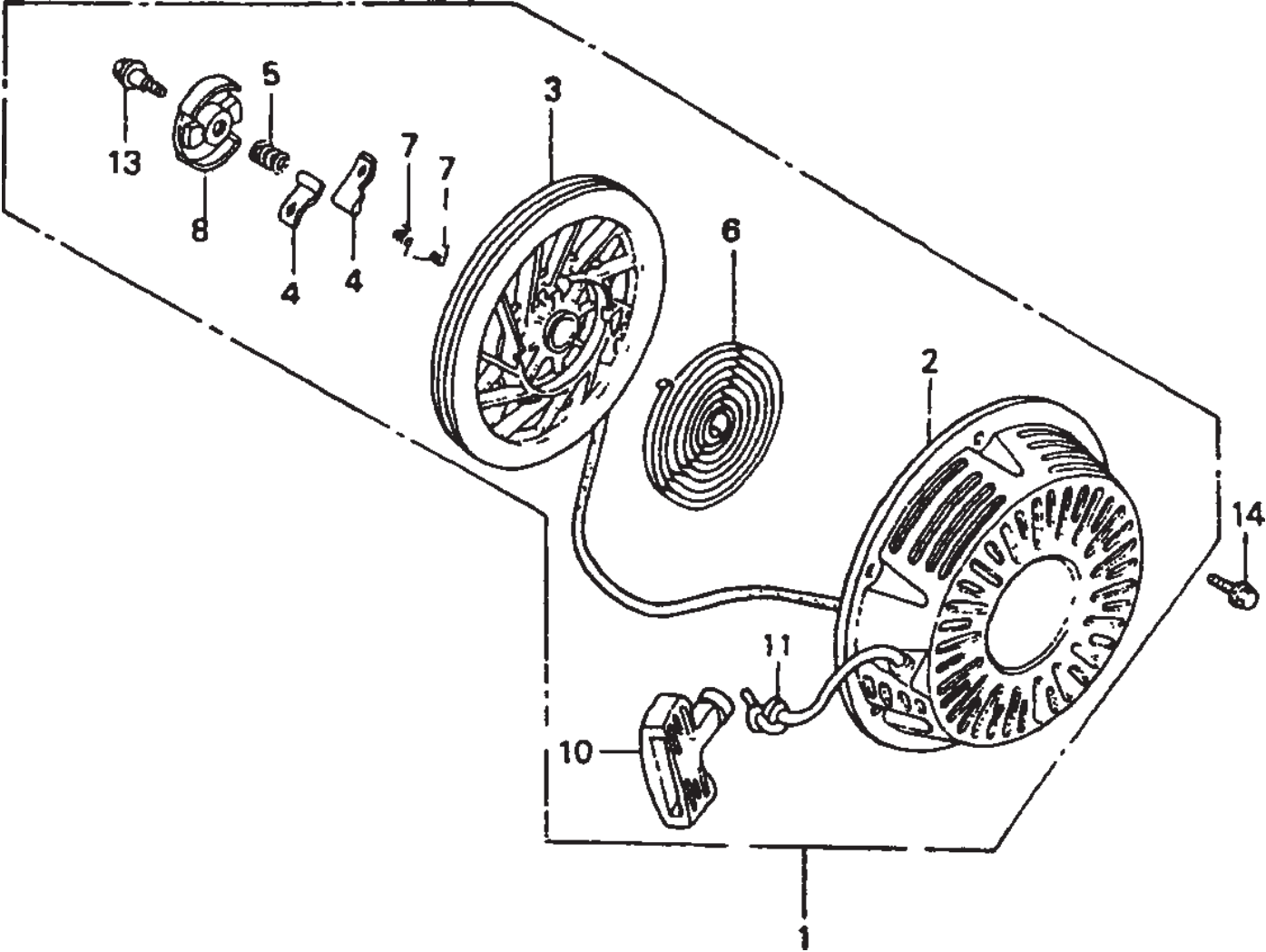

# HONDA GX-390K1SM32 — RECOIL STARTER ASSY.

## RECOIL STARTER ASSY.

<u>NO.</u>	<u>PART NO.</u>	<u>PART NAME</u>	<u>QTY.</u>	<u>REMARKS</u>
1	28400ZE3W08ZA	STARTER ASSY., RECOIL .....	1 .....	INCLUDES ITEMS W/*
2*	28410ZE3W08ZA	CASE COMP., RECOIL START.	1	
3*	28421ZE3W01	PULLEY, RECOIL STARTER	1	
4*	28422ZE2W01	RACHET, STARTER	2	
5*	28441ZE2W01	SPRING, FRICTION	1	
6*	28442ZE2W01	SPRING, STARTER RETURN	1	
7*	28443ZE2W01	SPRING, RATCHET	2	
8*	28444ZE2W01	RETAINER, SPRING	1	
10*	28461ZE2W02	GRIP, STARTER	1	
11*	28462ZE3W01	ROPE, RECOIL STARTER	1	
13*	90004ZE2W01	SCREW, CENTER	1	
14	957010600800	FLANGE BOLT 6X8	3	

**HONDA GX-390K1SM32 — FAN COVER ASSY.**

FAN COVER ASSY.

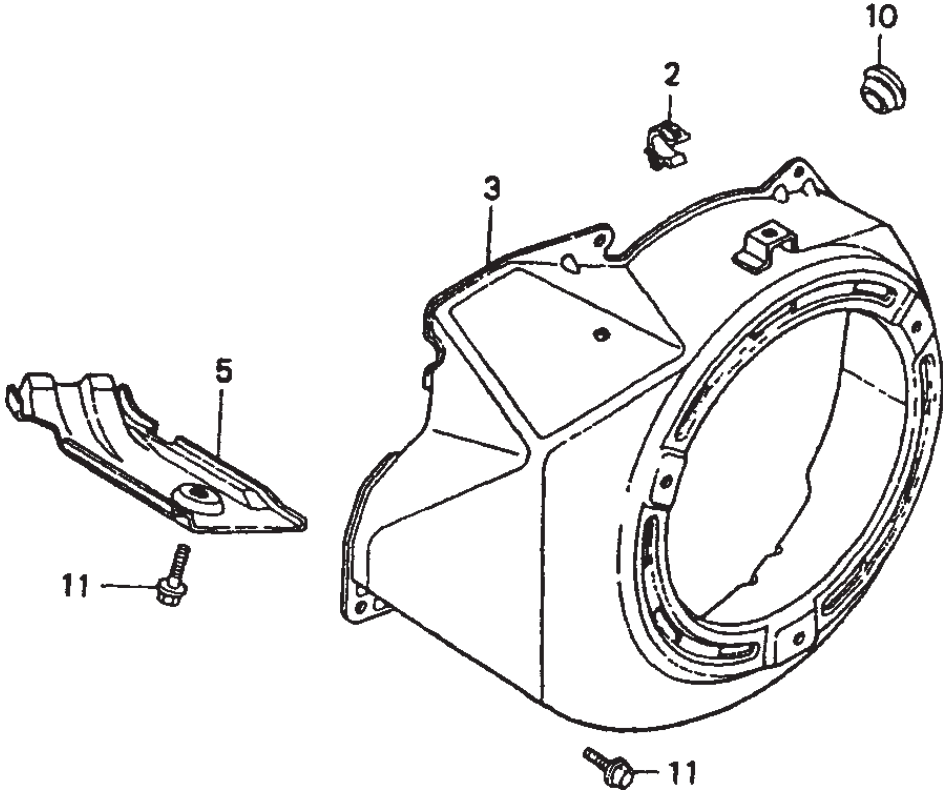

# HONDA GX-390K1SM32 — FAN COVER ASSY.

FAN COVER ASSY.

<u>NO.</u>	<u>PART NO.</u>	<u>PART NAME</u>	<u>QTY.</u>	<u>REMARKS</u>
2	16731ZE2003	CLIP, TUBE	1	
3	19610ZE3010ZA	COVER COMP., FAN	1	
5	19631ZE3W00	SHROUD	1	
10	81329567020	GROMMET, DRAIN HOLE	1	
11	90013883000	FLANGE BOLT 6X12	6	

# HONDA GX-390K1SM32 — CARBURETOR ASSY.

CARBURETOR ASSY.

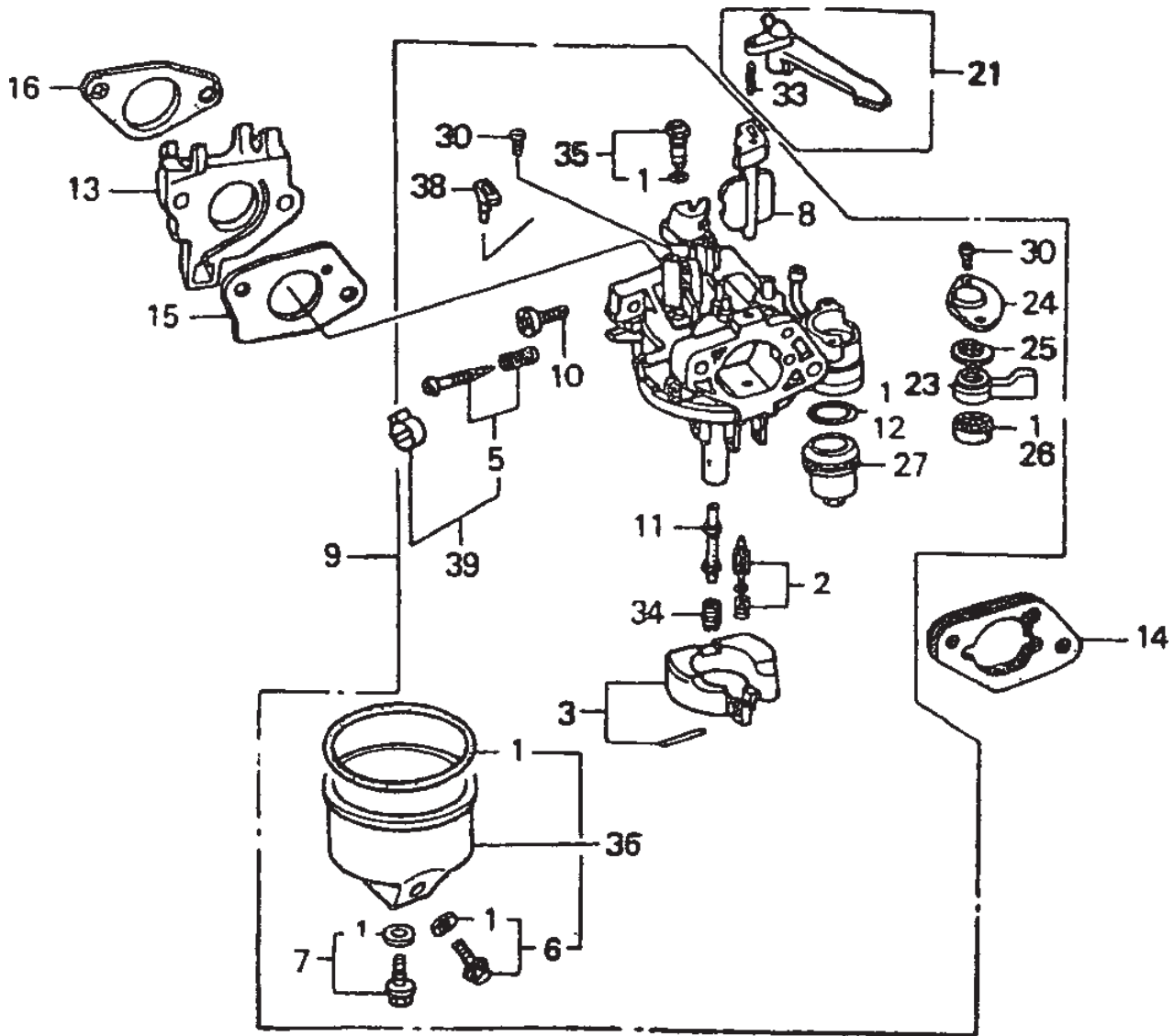

# HONDA GX-390K1SM32 — CARBURETOR ASSY.

## CARBURETOR ASSY.

<u>NO.</u>	<u>PART NO.</u>	<u>PART NAME</u>	<u>QTY.</u>	<u>REMARKS</u>
1*	16010ZE2812	GASKET SET	1	
2*	16011ZA0931	VALVE SET, FLOAT	1	
3*	16013ZA0931	FLOAT SET	1	
5*■	16016ZE0005	PILOT SCREW	1	
6*\$	16024ZE1811	DRAIN SCREW SET	1	
7*\$	16028ZE0005	SCREW SET	1	
8*	16044ZE3W20	CHOKE SET	1	
9	16100ZF6V01	CARBURETOR ASSY. (BE85B B)	1	..... INCLUDES ITEMS W/*
10*	16124ZE0005	SCREW, THROTTLE STOP	1	
11*	16166ZF6V00	NOZZLE, MAIN	1	
12*	16173001004	PACKING , CUP	1	
13	16211ZF6000	INSULATOR, CARBURETOR	1	
14	16220ZA0702	SPACER COMP., CARBURETOR	1	
15	16221ZF6800	PACKING, CARBURETOR	1	
16	16223ZE3W00	PACKING, INSULATOR	1	
21	16610ZE1000	CHOKE LEVER COMP.	1	..... INCLUDES ITEMS W/#
23*	16953ZE1812	LEVER, COCK	1	
24*	16954ZE1812	PLATE, LEVER SETTING	1	
25*	16956ZE1811	SPRING, COCK LEVER	1	
26*	16957ZE1812	PACKING, FUEL COCK	1	
27*	16967ZE0811	CUP, FUEL STRAINER	1	
30*	93500030061H	SCREW 3X6	3	
33#	9430520122	SPRING PIN 2X12	1	
34*	99101ZH80920	JET, MAIN #92	1	
35*	99204ZA00450	PILOT JET SET, PILOT #45 *5-3-4	1	
36*	16015ZE8005	CHAMBER SET, FLOAT	1	..... INCLUDES ITEMS W/\$
38*	16172ZE3W10	COLLAR SET	1	
39*	16016ZH7W01	SCREW SET	1	..... INCLUDES ITEMS W/■

# HONDA GX-390K1SM32 — AIR CLEANER ASSY.

AIR CLEANER ASSY.

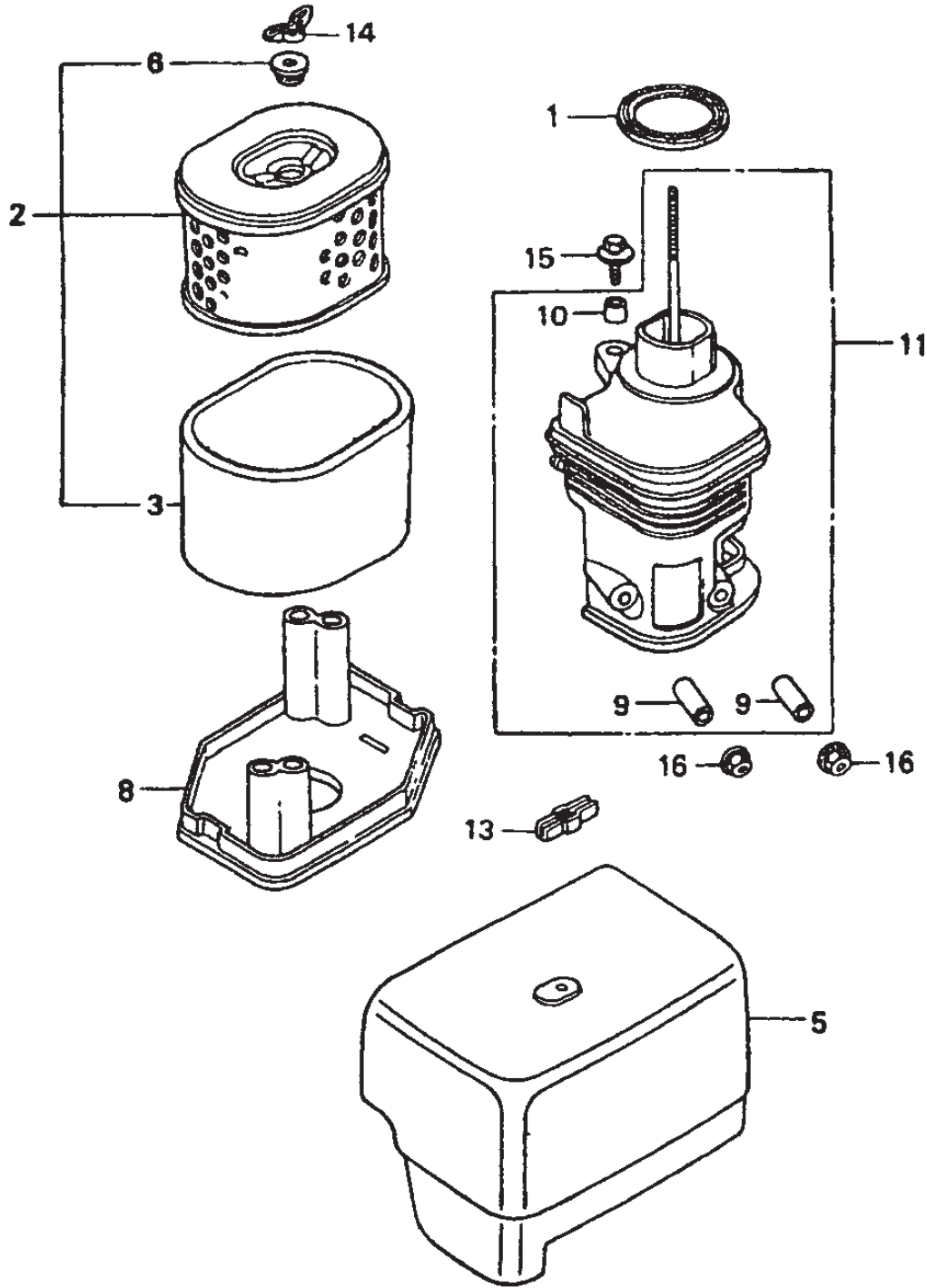

# HONDA GX-390K1SM32 — AIR CLEANER ASSY.

## AIR CLEANER ASSY.

<u>NO.</u>	<u>PART NO.</u>	<u>PART NAME</u>	<u>QTY.</u>	<u>REMARKS</u>
1	16271ZE2000	PACKING, ELBOW	1	
2	17210ZE3010	ELEMENT, AIR CLEANER .....	1 .....	INCLUDES ITEMS W/%
3%	17218ZE3000	FILTER, OUTER	1	
5	17231ZE3W00	COVER, AIR CLEANER	1	
6%	17232891000	GROMET, AIR CLEANER	1	
8	17235ZH9N00	NOSE, SILENCER	1	
9*	17238ZE2310	COLLAR, AIR CLEANER	2	
10*	17239ZE1000	COLLAR (B), AIR CLEANER	1	
11	17410ZH9N00	ELBOW COMP., AIR CLEANER ..	1 .....	INCLUDES ITEMS W/*
13	90203ZA0800	NUT,WING 6MM, BLACK	1	
14	90325044000	NUT	2	
15	90009ZE2003	BOLT-WASHER 6X22	1	
16	9405006000	FLANGE NUT 6MM	2	

# HONDA GX-390K1SM32 — MUFFLER ASSY.

MUFFLER ASSY.

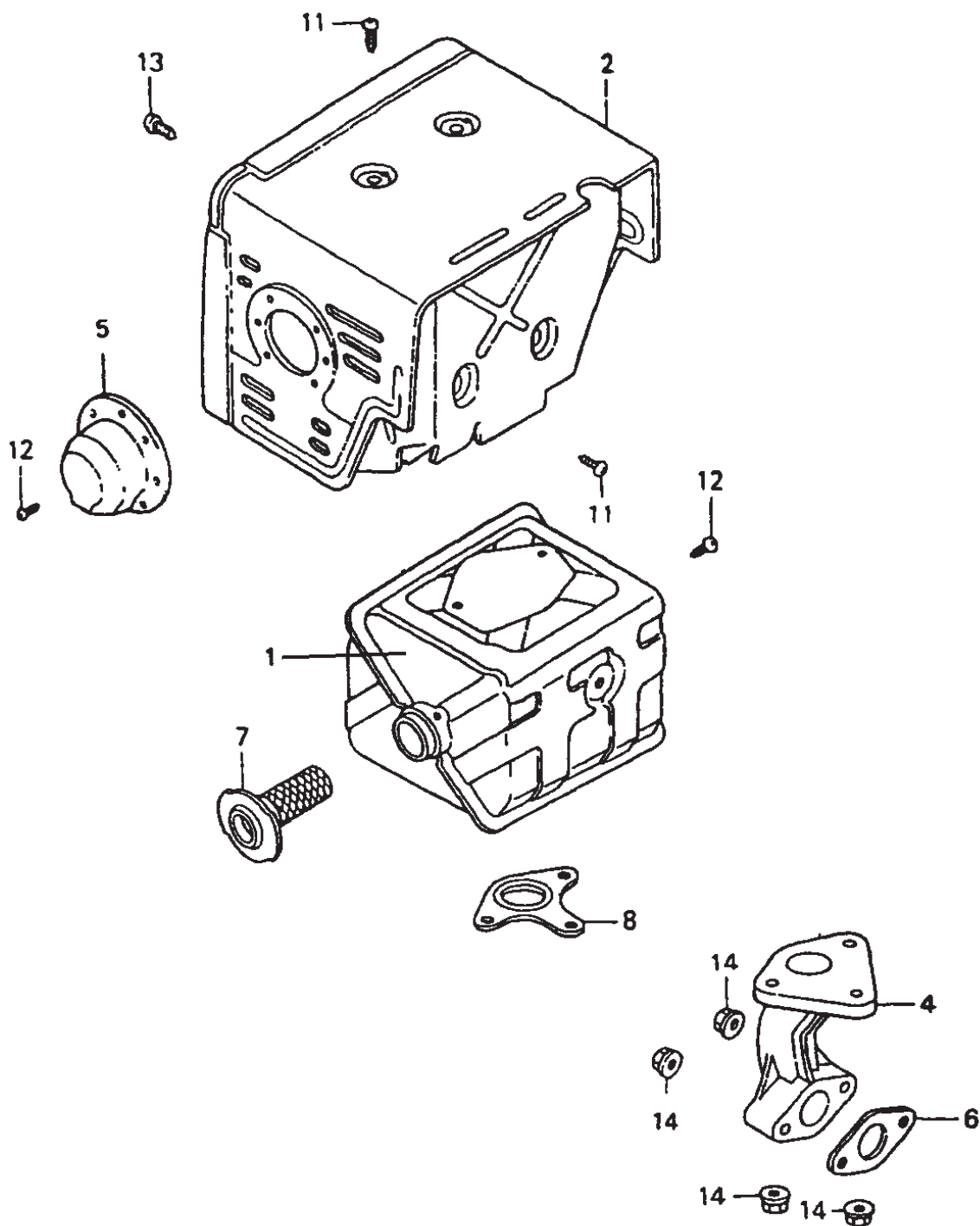

## HONDA GX-390K1SM32 — MUFFLER ASSY.

### MUFFLER ASSY.

<u>NO.</u>	<u>PART NO.</u>	<u>PART NAME</u>	<u>QTY.</u>	<u>REMARKS</u>
1	18310ZE2W61	MUFFLER COMP. (100DB)	1	
2	18320ZE2W61	PROTECTOR COMP., MUFFLER	1	
4	18330ZE2W00	PIPE, EXHAUST	1	
5	18331ZE3810	CAP, MUFFLER	1	
6	18333ZF6W01	GASKET, EX. PIPE	1	
7	18355ZE2W00	ARRESTER, SPARK	1	
8	18381ZE2W10	GASKET, MUFFLER ARRESTER	1	
11	90050ZE1000	TAPPING SCREW 5X8	4	
12	90055ZE1000	TAPPING SCREW 4X6	3	
13	90006ZE2000	TAPPING SCREW 6X10	1	
14	9405008000	FLANGE NUT M8	5	

# HONDA GX-390K1SM32 — FUEL TANK ASSY.

FUEL TANK ASSY.

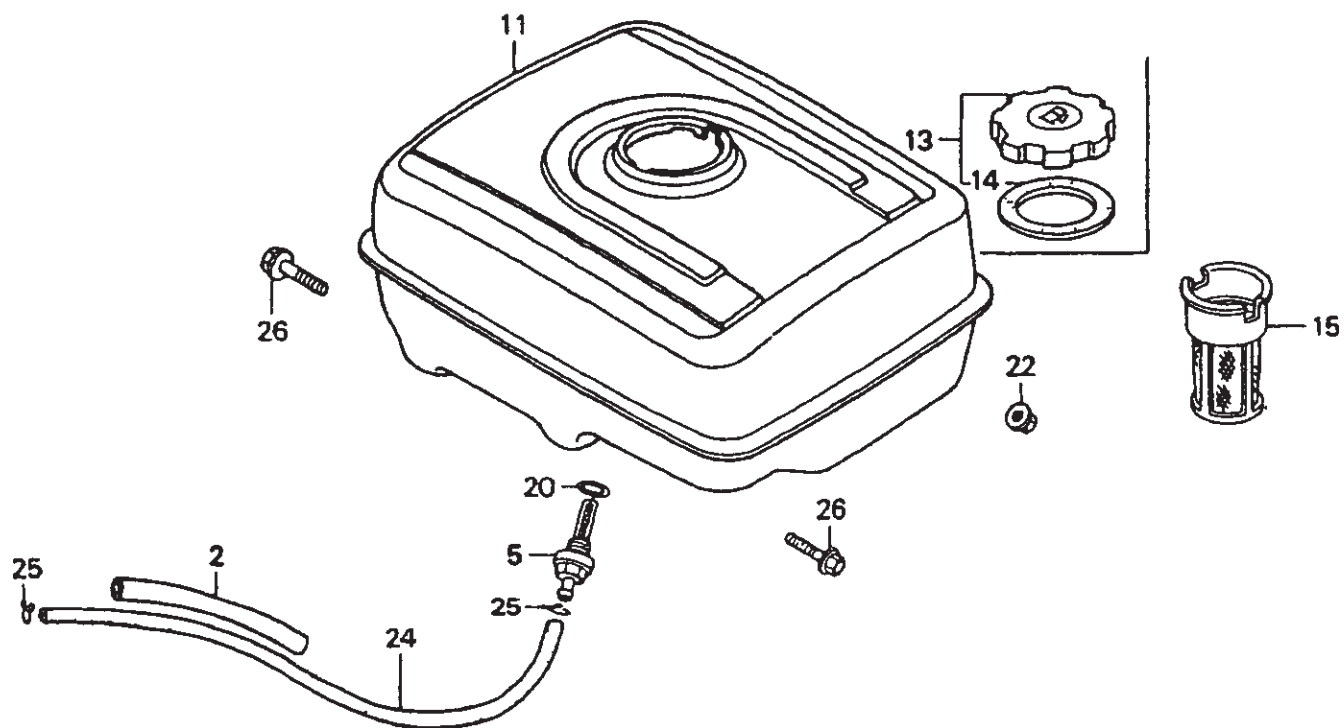

# HONDA GX-390K1SM32 — FUEL TANK ASSY.

## FUEL TANK ASSY.

<u>NO.</u>	<u>PART NO.</u>	<u>PART NAME</u>	<u>QTY.</u>	<u>REMARKS</u>
2	16854ZH8000	RUBBER, SUPPORT (107MM)	1	
5	16955ZE1000	JOINT, FUEL TANK	1	
11	17510ZE3010ZA	TANK COMP., FUEL	1	
13	17620ZH7023	FUEL TANK CAP CP .....	1	INCLUDES ITEMS W/*
14*	17631ZH7003	PACKING	1	
15	17672ZE2W01	FUEL FILTER	1	
20	91353671004	O-RING 14MM	1	
22	9405008000	FLANGE NUT M8	2	
24	950014523540	TUBE, FUEL 4.5X235	1	
25	9500202080	CLIP, TUBE	2	
26	957010802500	FLANGE BOLT 8X25	2	

# HONDA GX-390K1SM32 — FLYWHEEL ASSY.

FLYWHEEL ASSY.

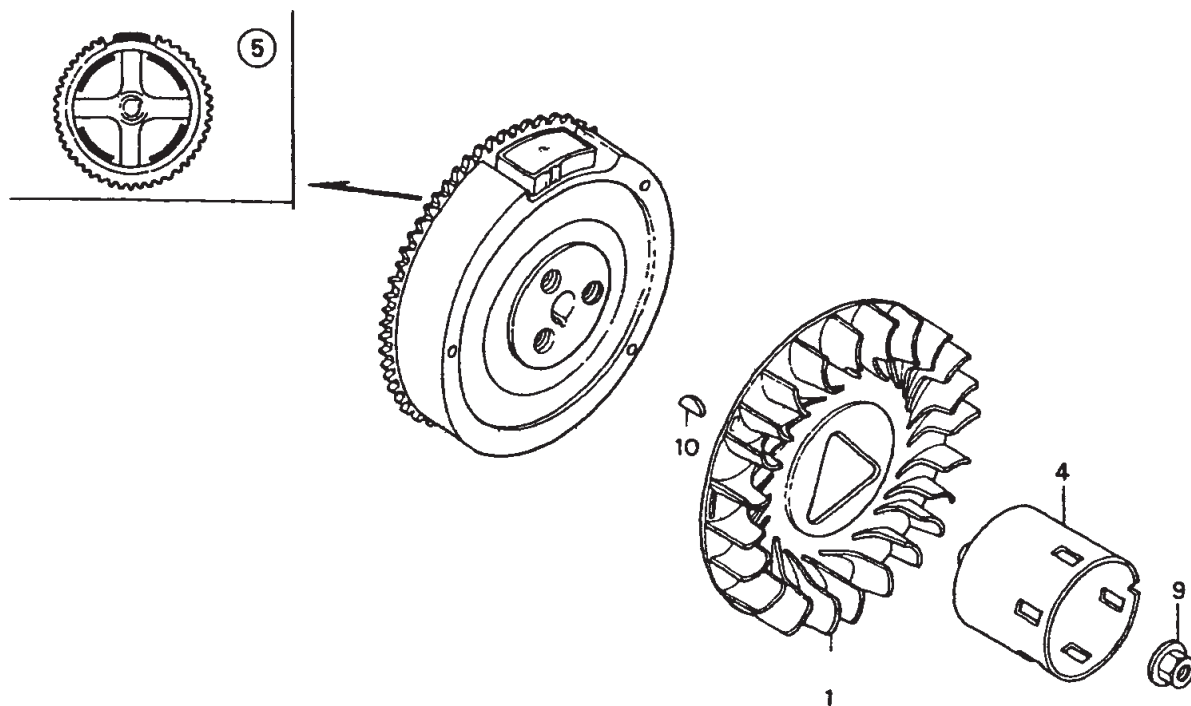

# HONDA GX-390K1SM32 — FLYWHEEL ASSY.

FLYWHEEL ASSY.

<u>NO.</u>	<u>PART NO.</u>	<u>PART NAME</u>	<u>QTY.</u>	<u>REMARKS</u>
1	19511ZE3000	FAN, COOLING	1	
4	28451ZE3W01	PULLEY, STARTER	1	
5	31100ZE3W01	FLYWHEEL COMP.	1	
9	90201ZE3V00	NUT, SPECIAL 16MM	1	
10	90741ZE2000	KEY, SPECIAL WOODRUFF 25X18	1	

# HONDA GX-390K1SM32 — IGNITION COIL ASSY.

IGNITION COIL ASSY.

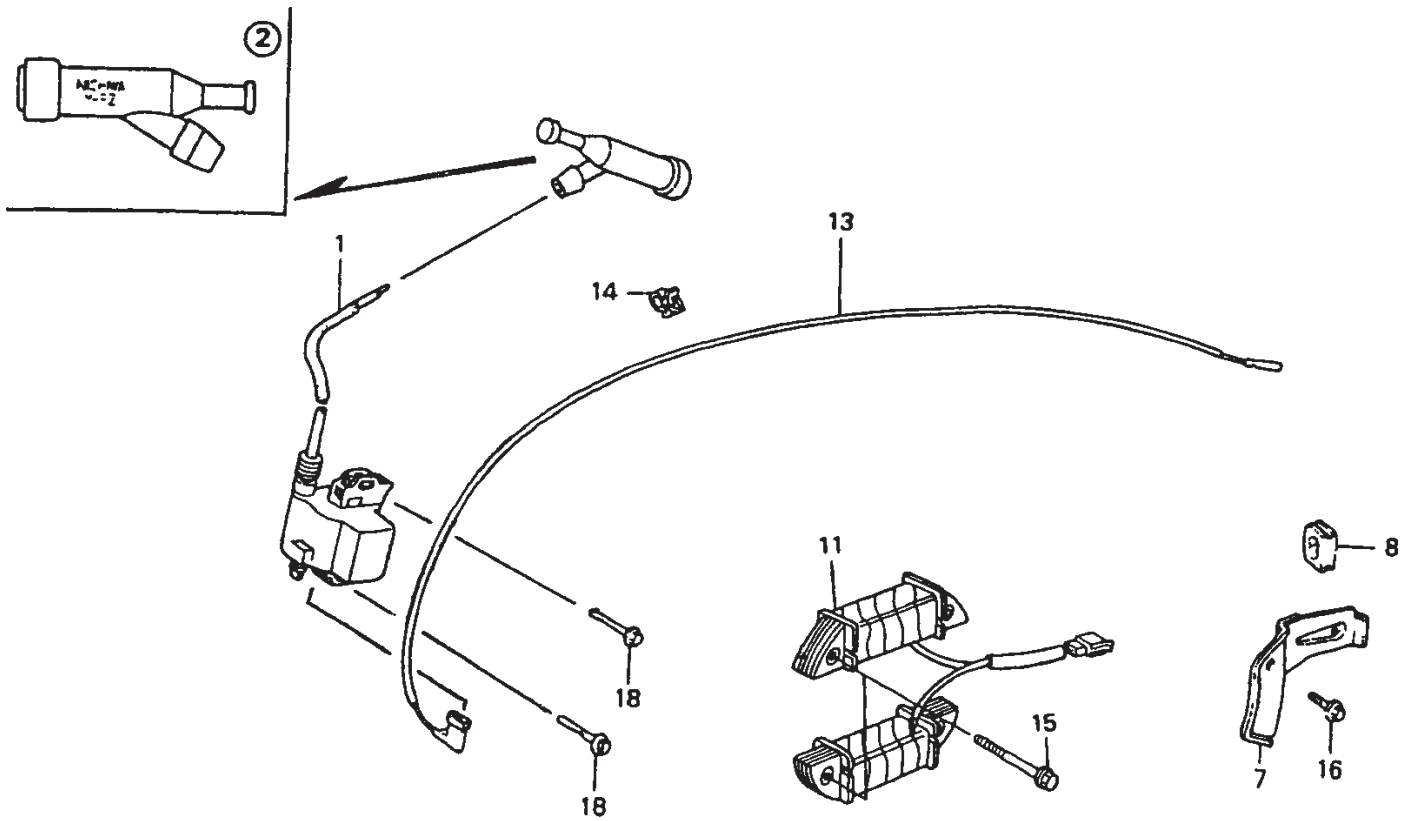

## HONDA GX-390K1SM32 — IGNITION COIL ASSY.

### IGNITION COIL ASSY.

<u>NO.</u>	<u>PART NO.</u>	<u>PART NAME</u>	<u>QTY.</u>	<u>REMARKS</u>
1	30500ZF6W01	COIL ASSY., IGNITION	1	
2	30600ZE1013	SPARK PLUG CAP	1	
7	31511ZE3000	CLAMPER, CORD	1	
8	31512ZE2000	GROMMET, CORD	1	
11	31630ZE2861	COIL ASSY., CHARGE (1A)	1	
13	36101ZE2701	CORD, STOP SWITCH (430MM)	1	
14	36103ZE1000	HOLDER, STOP SWITCH CORD	1	
15	90012888000	FLANGE BOLT	4	
16	90013883000	FLANGE BOLT 6X12	1	
18	90015883000	FLANGE BOLT 6X28	2	

# HONDA GX-390K1SM32 — STARTER MOTOR ASSY.

STARTER MOTOR ASSY.

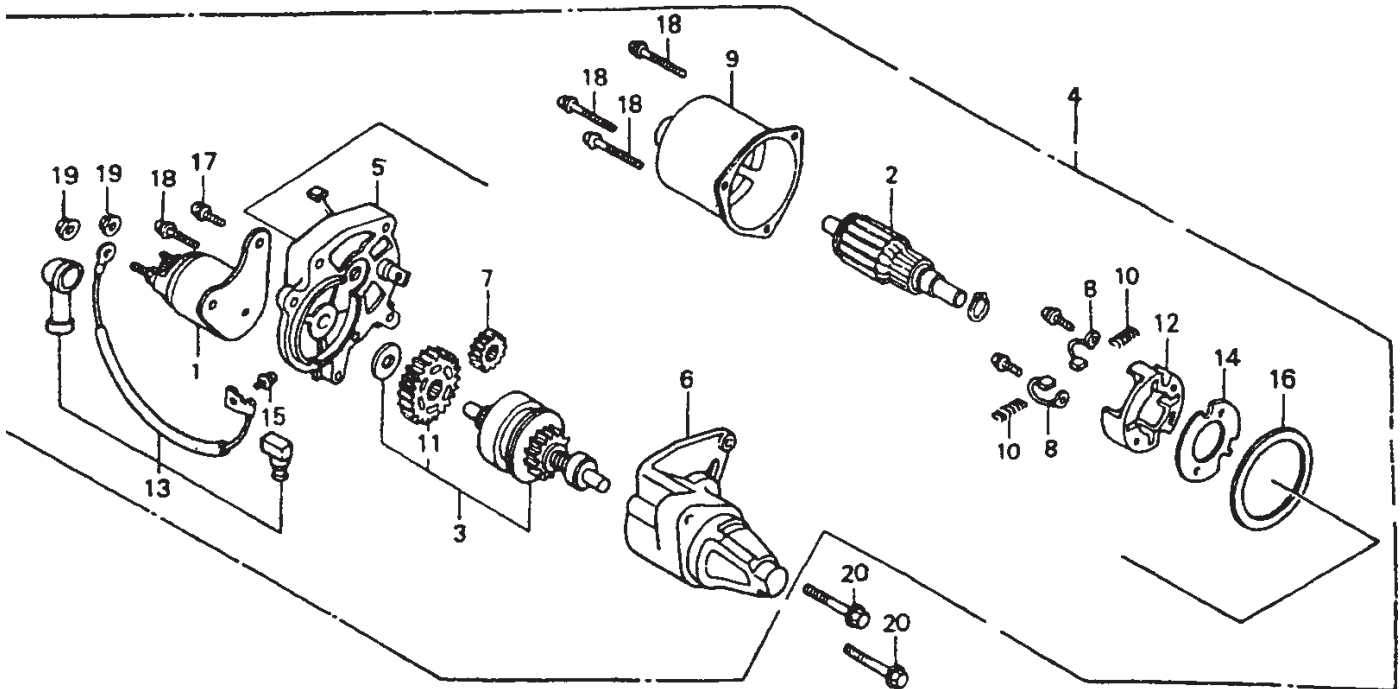

# HONDA GX-390K1SM32 — STARTER MOTOR ASSY.

## STARTER MOTOR ASSY.

<u>NO.</u>	<u>PART NO.</u>	<u>PART NAME</u>	<u>QTY.</u>	<u>REMARKS</u>
1*	31204ZA0003	CONTACTOR ASSY.	1	
2*	31206ZE3003	ARMATURE COMP.	1	
3*	31207ZE3003	CLUTCH COMP., OVERRUN.	1	
4	31210ZE3013	MOTOR UNIT, STARTER .....	1	INCLUDES ITEMS W/*
5*	31211ZE2003	BRACKET, CENTER	1	
6*	31212ZE3003	BRACKET, FR.	1	
7*	31213ZE2003	GEAR, DRIVE PINION	1	
8*	31215ZE2003	BRUSH	2	
9*	31218ZE3003	YOKE COMP.	1	
10*	31219ZE2003	SPRING, BRUSH RETURN	4	
11*	31222ZE3791	GEAR, REDUCTION	1	
12*	31231ZE2003	HOLDER, BRUSH	1	
13*	31232ZE3003	HOLDER, BRUSH	1	
14*	31233ZE2003	INSULATOR	1	
15*	90110ZE2003	SCREW-WASHER 4X6	1	
16*	91601ZE2003	PACKING	1	
17*	90007ZE2003	BOLT-WASHER 5X14	2	
18*	938920503218	SCREW-WASHER 5X32	4	
19*	9407006080	NUT-WASHER 6MM	2	
20	957010803508	FLANGE BOLT 8X35	2	

# HONDA GX-390K1SM32 — CONTROL ASSY.

CONTROL ASSY.

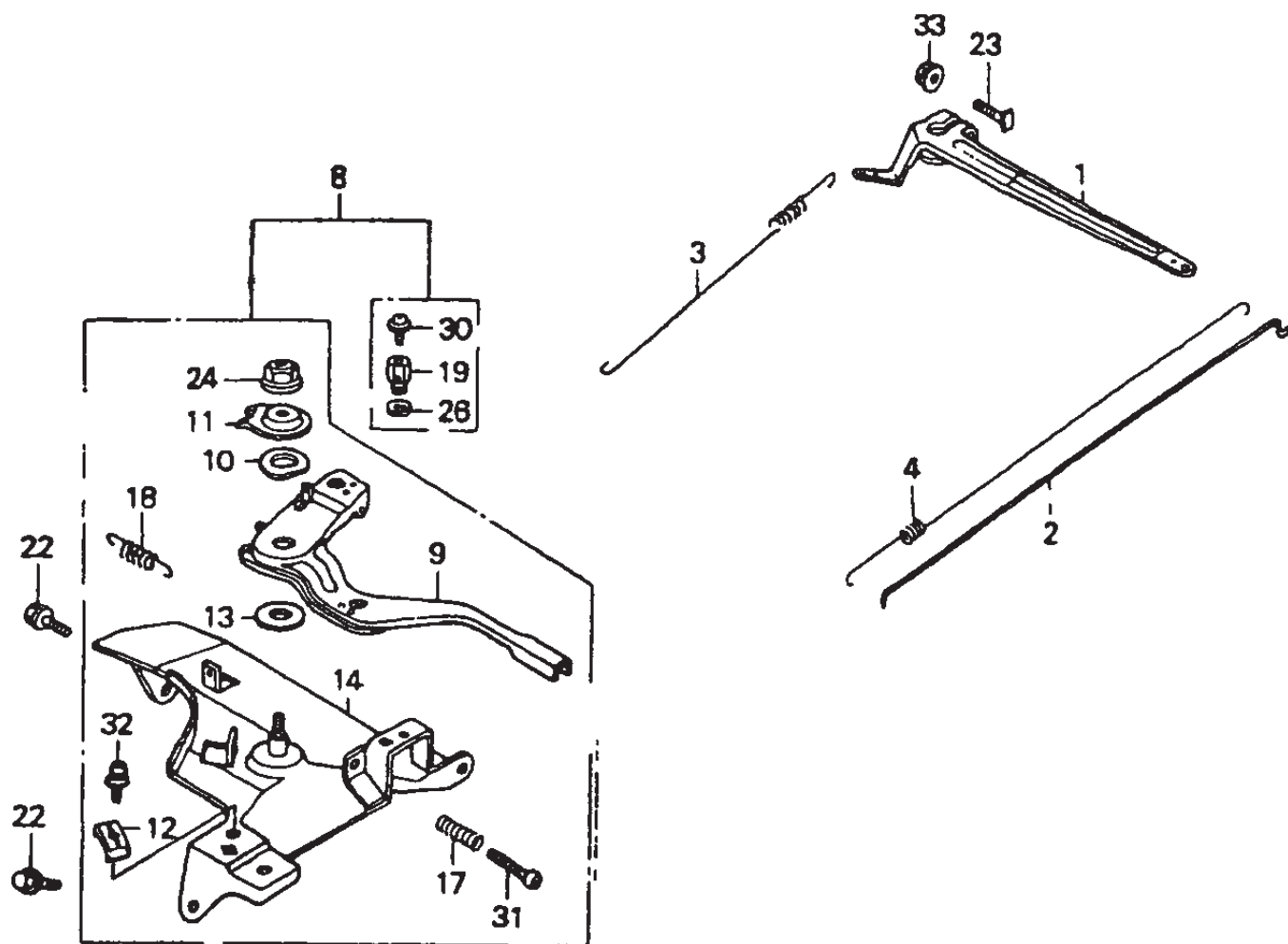

# HONDA GX-390K1SM32 — CONTROL ASSY.

## CONTROL ASSY.

<u>NO.</u>	<u>PART NO.</u>	<u>PART NAME</u>	<u>QTY.</u>	<u>REMARKS</u>
1	16551ZE3000	ARM, GOVERNOR	1	
2	16555ZE3000	ROD, GOVERNOR	1	
3	16561ZE3000	SPRING, GOVERNOR	1	
4	16562ZE3000	SPRING, THROTTLE RETURN	1	
8	16570ZE3W10	CONTROL ASSY. (REMOTE) .....	1	..... INCLUDES ITEMS W/*
9*	16571ZE3W00	LEVER, CONTROL	1	
10*	16574ZE1000	LEVER SPRING	1	
11*	16575ZE2W00	WASHER, CONTROL LEVER	1	
12*	16576891000	HOLDER, CABLE	1	
13*	16578ZE1000	SPACER, CONTROL LEVER	1	
14*	16581ZE3W00	BASE COMP., CONTROL	1	
17*	16584883300	ADJUSTING SPRING	1	
18*	16592883310	SPRING, CABLE RETURN	1	
19*	16594883010	WIRE HOLDER	1	
22	90013883000	FLANGE BOLT 6X12	2	
23	90015ZE5010	BOLT, GOVERNOR ARM	1	
24*	90114SA0000	LOCK NUT 6MM	1	
26*	90605230000	CIR CLIP 5MM	1	
30*	93500040060H	SCREW 4X6	1	
31*	93500050320A	PAN SCREW 5X32	1	
32*	93500050160A	SCREW 5X16	1	
33	9405006000	FLANGE NUT 6MM	1	

# HONDA GX-390K1SM32 — CONTROL BOX ASSY.

CONTROL BOX ASSY.

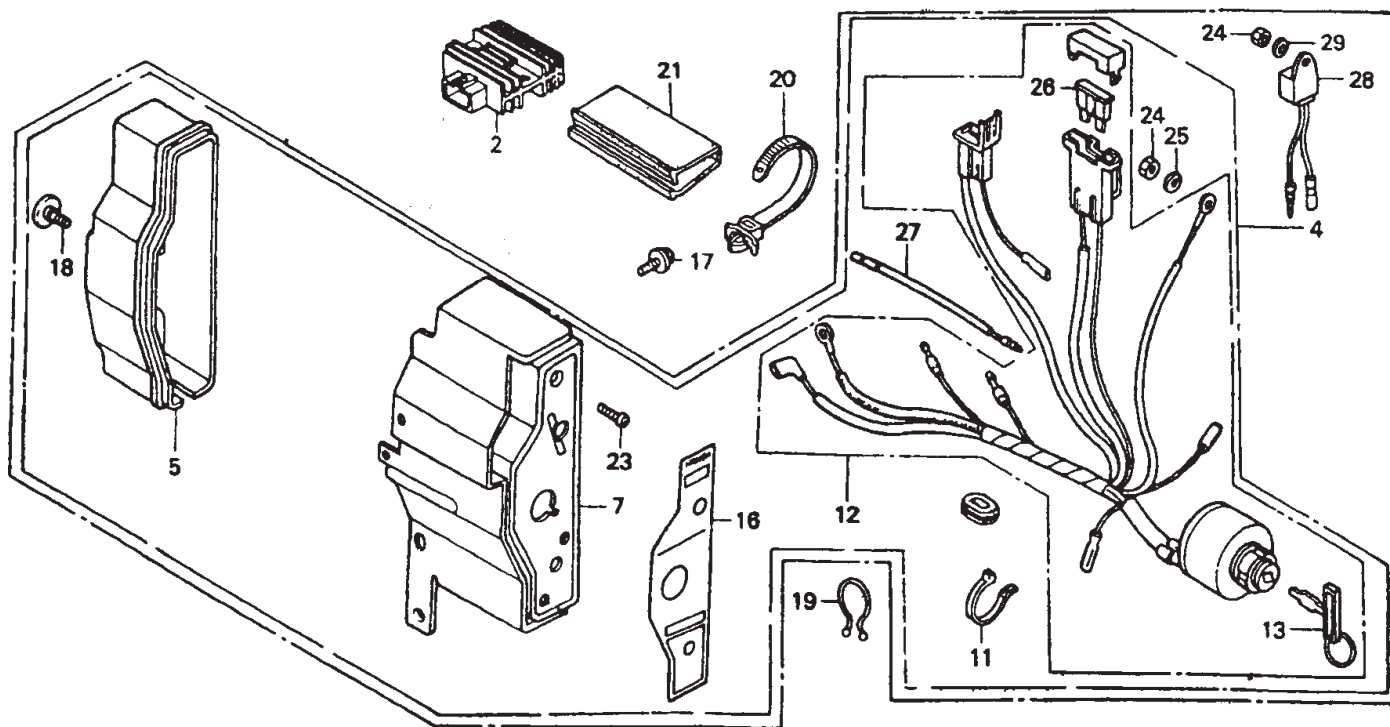

# HONDA GX-390K1SM32 — CONTROL BOX ASSY.

## CONTROL BOX ASSY.

<u>NO.</u>	<u>PART NO.</u>	<u>PART NAME</u>	<u>QTY.</u>	<u>REMARKS</u>
2	31600ZE2861	REGULATOR ASSY., RECT	1	
4	31610ZE3W33ZA	BOX ASSY., CONTROL .....	1 .....	INCLUDES ITEMS W/*
5*	31612ZE2003	CASE, CONTROL	1	
6	31614ZE2003	BRACKET, CASE MOUNTING	1	
7*	31615ZE3003ZB	PANEL COMP., CONTROL	1	
11*	32902892003	BAND	1	
12*	35100ZE2862	SWITCH ASSY., COMBINATION .....	1 .....	INCLUDES ITEMS W/%
13*%	35111880003	KEY COMP.	2	
17	90013883000	FLANGE BOLT 6X12	2	
18*	90380MA6010	SCREW, SPECIAL 6X12	1	
19	90630751000	CLIP, PURSE LOCK	1	
20	90672SA0003	STRAP, CABLE 118MM	1	
21	91406ZE2003	TUBE, FASTENER 30MM	1	
23*	93500040120H	PAN SCREW 4X12	1	
24*	94001043900S	NUT, HEX. 4MM	1	
25*	9411104800	WASHER, SPRING 4MM	1	
26*%	9820031500	FUSE, BLADE (15A)	1	
27*	32197ZE1003	SUB HARNESS	1	
28	34150ZH7003	ALERT UNIT, OIL	1	
29	9410104800	WASHER, PLAIN 4MM	1	

# HONDA GX-390K1SM32 — LABEL ASSY.

LABEL ASSY.

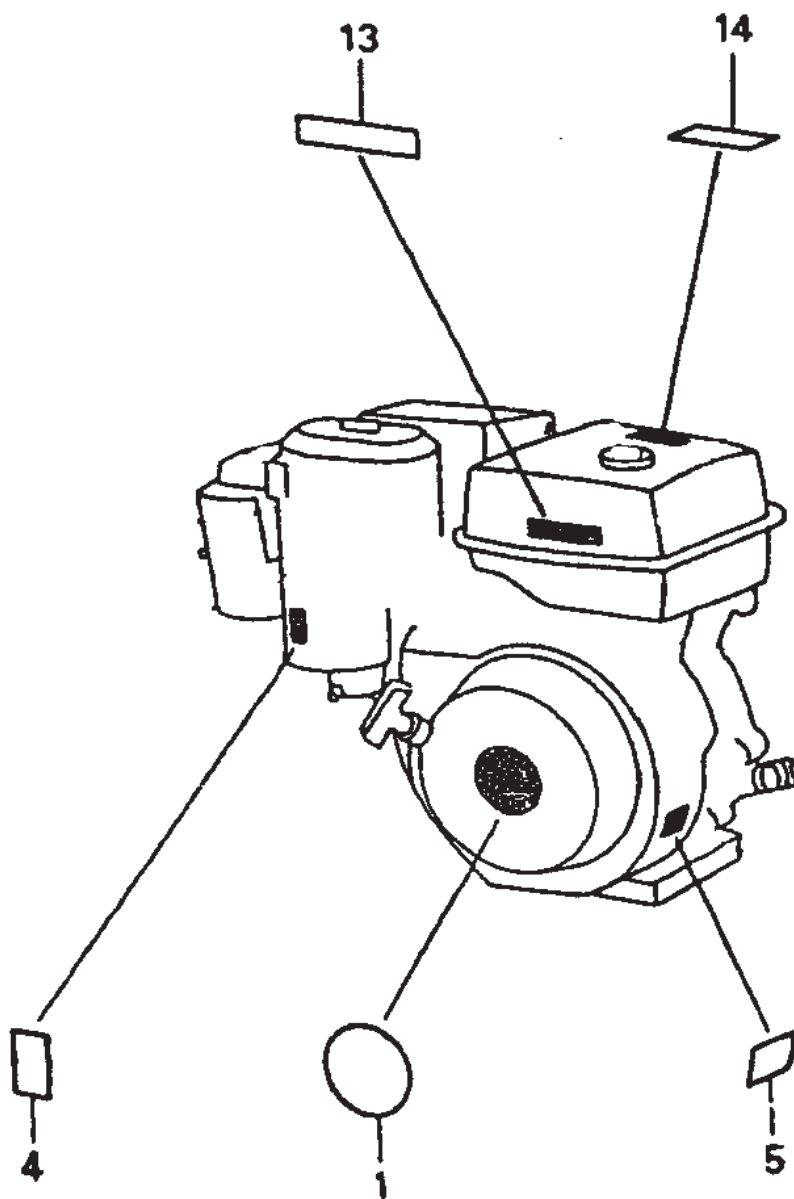

# HONDA GX-390K1SM32 — LABEL ASSY.

LABEL ASSY.

<u>NO.</u>	<u>PART NO.</u>	<u>PART NAME</u>	<u>QTY.</u>	<u>REMARKS</u>
1	87521ZF6W01	EMBLEM	1	
4	87528ZE2810	MARK, CHOKE (ORANGE) .....	1 .....	RECOIL-TYPE
4	87528777000	MARK, CHOKE .....	1 .....	SELFSTARTER
5	87530ZF6W00	LABEL, SPECIFICATION	1	
13	87520ZH8000	LABEL, COMBINATION	1	
14	87526ZH8000	LABEL, COMBINATION	1	

**PAYMENT TERMS**

Terms of payment for parts are net 10 days.

**FREIGHT POLICY**

All parts orders will be shipped collect or prepaid with the charges added to the invoice. All shipments are F.O.B. point of origin. Multiquip's responsibility ceases when a signed manifest has been obtained from the carrier, and any claim for shortage or damage must be settled between the consignee and the carrier.

**MINIMUM ORDER**

The minimum charge for orders from Multiquip is \$15.00 net. Customers will be asked for instructions regarding handling of orders not meeting this requirement.

**RETURNED GOODS POLICY**

Return shipments will be accepted and credit will be allowed, subject to the following provisions:

1. A Returned Material Authorization must be approved by Multiquip prior to shipment.
2. To obtain a Return Material Authorization, a list must be provided to Multiquip Parts Sales that defines item numbers, quantities, and descriptions of the items to be returned.
  - a. The parts numbers and descriptions must match the current parts price list.
  - b. The list must be typed or computer generated.
  - c. The list must state the reason(s) for the return.
  - d. The list must reference the sales order(s) or invoice(s) under which the items were originally purchased.
  - e. The list must include the name and phone number of the person requesting the RMA.
3. A copy of the Return Material Authorization must accompany the return shipment.
4. Freight is at the sender's expense. All parts must be returned freight prepaid to Multiquip's designated receiving point.

5. Parts must be in new and resalable condition, in the original Multiquip package (if any), and with Multiquip part numbers clearly marked.
6. The following items are not returnable:
  - a. Obsolete parts. (If an item is in the price book and shows as being replaced by another item, it is obsolete.)
  - b. Any parts with a limited shelf life (such as gaskets, seals, "O" rings, and other rubber parts) that were purchased more than six months prior to the return date.
  - c. Anyline item with an extended dealer net price of less than \$5.00.
  - d. Special order items.
  - e. Electrical components.
  - f. Paint, chemicals, and lubricants.
  - g. Decals and paper products.
  - h. Items purchased in kits.
7. The sender will be notified of any material received that is not acceptable.
8. Such material will be held for five working days from notification, pending instructions. If a reply is not received within five days, the material will be returned to the sender at his expense.
9. Credit on returned parts will be issued at dealer net price at time of the original purchase, less a 15% restocking charge.
10. In cases where an item is accepted, for which the original purchase document can not be determined, the price will be based on the list price that was effective twelve months prior to the RMA date.
11. Credit issued will be applied to future purchases only.

**PRICING AND REBATES**

Prices are subject to change without prior notice. Price changes are effective on a specific date and all orders received on or after that date will be billed at the revised price.

Rebates for price declines and added charges for price increases will not be made for stock on hand at the time of any price change.

Multiquip reserves the right to quote and sell direct to Government agencies, and to Original Equipment Manufacturer accounts who use our products as integral parts of their own products.

**SPECIAL EXPEDITING SERVICE**

A \$35.00 surcharge will be added to the invoice for special handling including bus shipments, insured parcel post or in cases where Multiquip must personally deliver the parts to the carrier.

**LIMITATIONS OF SELLER'S LIABILITY**

Multiquip shall not be liable here under for damages in excess of the purchase price of the item with respect to which damages are claimed, and in no event shall Multiquip be liable for loss of profit or good will or for any other special, consequential or incidental damages.

**LIMITATION OF WARRANTIES**

No warranties, express or implied, are made in connection with the sale of parts or trade accessories nor as to any engine not manufactured by Multiquip. Such warranties made in connection with the sale of new, complete units are made exclusively by a statement of warranty packaged with such units, and Multiquip neither assumes nor authorizes any person to assume for it any other obligation or liability whatever in connection with the sale of its products. Apart from such written statement of warranty, there are no warranties, express, implied or statutory, which extend beyond the description of the products on the face hereof.



# OPERATION AND PARTS MANUAL

## **HERE'S HOW TO GET HELP**

*PLEASE HAVE THE MODEL AND SERIAL  
NUMBER ON-HAND WHEN CALLING*

### ***PARTS DEPARTMENT***

*800-427-1244 or 310-537-3700*

*FAX: 800-672-7877 or 310-637-3284*

### ***SERVICE DEPARTMENT***

*800-421-1244*

*FAX: 310- 537-4259*

### ***TECHNICAL ASSISTANCE***

*800-478-1244*

*FAX: 310- 631-5032*

### ***WARRANTY DEPARTMENT***

*888-661-4279, or 310-661-4279*

*FAX: 310- 537-1173*



**MULTIQUIP INC.**  
POST OFFICE BOX 6254  
CARSON, CA 90749  
310-537-3700 • 800-421-1244  
FAX: 310-537-3927  
E-MAIL: [mq@multiquip.com](mailto:mq@multiquip.com)  
WWW: [multiquip.com](http://multiquip.com)

Atlanta • Boise • Dallas • Houston • Newark  
Quebec, Canada • Manchester, UK • Rio De Janeiro, BR • Guadalajara, MX



manufactured for Multiquip Inc.  
by  
**MIKASA SANGYO CO., LTD. Tokyo, Japan**