

# OPERATION AND PARTS MANUAL



*Mikasa* **SERIES**  
**MODEL MT-76D2**  
**TAMPING RAMMER**  
**(YANMAR DIESEL ENGINE)**

Revision #4 (06/18/07)

To find the latest revision of this  
publication, visit our website at:  
[www.multiquip.com](http://www.multiquip.com)



**THIS MANUAL MUST ACCOMPANY THE EQUIPMENT AT ALL TIMES.**



**WARNING**



**CALIFORNIA — Proposition 65 Warning**

Engine exhaust and some of its constituents are known to the State of California to cause cancer, birth defects and other reproductive harm.



# MT-76D2 TAMPING RAMMER —TABLE OF CONTENTS

Proposition 65 Warning .....	2
Table Of Contents .....	4
Parts Ordering Procedures .....	5
Safety Message Alert Symbols .....	6-7
Rules For Safe Operation .....	8-9
Operation and Safety Decals .....	10
General Information .....	11

## **MIKASA MT-76D2 — Tamping Rammer**

Specifications .....	12
Controls and Components .....	13
Basic Engine .....	14
Initial Start-up .....	15-16
Operation .....	17
Maintenance .....	18-19
Troubleshooting .....	20-21
Explanation Of Parts Section .....	22
Suggested Spare Parts .....	23
Name Plate And Decals .....	24-25
Crankcase and Engine Assembly .....	26-29
Guide Cylinder and Foot Assembly .....	30-31
Tank and Handle Assembly .....	32-33

## **YANMARL-48V6 ENGINE**

Cylinder Block Assembly .....	34-35
Cylinder Head Assembly .....	36-37
Crankshaft and Camshaft Assembly .....	38-39
Piston Assembly .....	40-41
Lub.,Oil Pump and Governor Assembly .....	42-43
Cooling and Starting Assembly .....	44-45
Fuel Injection Pump Assembly .....	46-47
Air Cleaner Assembly .....	48-49
Muffler Assembly .....	50-51
Tools, Labels and Gasket Set Assembly .....	52-53
Accessories Assembly .....	54-55

Terms and Condition Of Sale — Parts .....	56
---	----

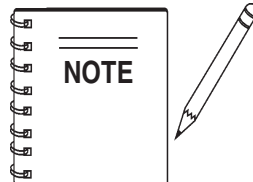

*Specification and part number are  
subject to change without notice.*

www.multiquip.com

**Ordering parts has never been easier!  
Choose from three easy options:**



**Order via Internet (Dealers Only):**

Order parts on-line using Multiquip's SmartEquip website!

- View Parts Diagrams
- Order Parts
- Print Specification Information



If you have an MQ Account, to obtain a Username and Password, E-mail us at: **parts@multiquip.com**.

To obtain an MQ Account, contact your District Sales Manager for more information.

Goto [www.multiquip.com](http://www.multiquip.com) and click on **Order Parts** to log in and save!

Use the **internet** and qualify for a **5% Discount** on *Standard orders* for all orders which include complete part numbers.\*

Note: Discounts Are Subject To Change



**Order via Fax (Dealers Only):**

All customers are welcome to order parts via Fax.

**Domestic (US) Customers dial:**  
1-800-6-PARTS-7 (800-672-7877)

**Fax** your order in and qualify for a **2% Discount** on *Standard orders* for all orders which include complete part numbers.\*

Note: Discounts Are Subject To Change



**Order via Phone: Domestic (US) Dealers Call:**  
1-800-427-1244

**Non-Dealer Customers:**

Contact your local Multiquip Dealer for parts or call 800-427-1244 for help in locating a dealer near you.



**International Customers** should contact their local Multiquip Representatives for Parts Ordering information.

**When ordering parts, please supply:**

- |   |  |
|---|--|
| <input type="checkbox"/> Dealer Account Number                                | <input type="checkbox"/> Specify Preferred Method of Shipment: |
| <input type="checkbox"/> Dealer Name and Address                              | ✓ UPS/Fed Ex                      ✓ DHL                        |
| <input type="checkbox"/> Shipping Address (if different than billing address) | ■ Priority One                    ✓ Truck                      |
| <input type="checkbox"/> Return Fax Number                                    | ■ Ground   |
| <input type="checkbox"/> Applicable Model Number                              | ■ Next Day   |
| <input type="checkbox"/> Quantity, Part Number and Description of Each Part   | ■ Second/Third Day   |

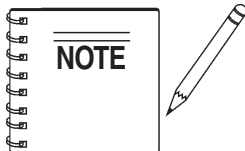

All orders are treated as *Standard Orders* and will ship the same day if received prior to 3PM PST.

**WE ACCEPT ALL MAJOR CREDIT CARDS!**



# MT-76D2 TAMPING RAMMER — SAFETY MESSAGE ALERT SYMBOLS

## FOR YOUR SAFETY AND THE SAFETY OF OTHERS!

Safety precautions should be followed at all times when operating this equipment. Failure to read and understand the Safety Messages and Operating Instructions could result in injury to yourself and others.

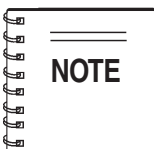

This Owner's Manual has been developed to provide complete instructions for the safe and efficient operation of the **MQ Mikasa Model MT-76D2 Tamping Rammer**. Refer to the engine manufacturer's instructions for data relative to its safe operation.

**Before using this rammer, ensure that the operating individual has read and understood all instructions in this manual.**

## SAFETY MESSAGE ALERT SYMBOLS

The three (3) Safety Messages shown below will inform you about potential hazards that could injure you or others. The Safety Messages specifically address the level of exposure to the operator, and are preceded by one of three words: **DANGER**,

### **DANGER**

You **WILL** be **KILLED** or **SERIOUSLY INJURED** if you **DO NOT** follow these directions.

### **WARNING**

You **CAN** be **KILLED** or **SERIOUSLY INJURED** if you **DO NOT** follow these directions.

### **CAUTION**

You **CAN** be **INJURED** if you **DO NOT** follow these directions.

## HAZARD SYMBOLS

Potential hazards associated with the operation of a **MT-76D2 Tamping Rammer** will be referenced with Hazard Symbols which appear throughout this manual, and will be referenced in conjunction with Safety Message Alert Symbols.

### **WARNING**

#### Lethal Exhaust Gas Hazards

Engine exhaust gases contain poisonous carbon monoxide. This gas is colorless and odorless, and can cause death if inhaled. **NEVER** operate this equipment in a confined area or enclosed structure that does not provide ample free flow air.



### **WARNING**

#### Explosive Fuel Hazards

**Fuel** is extremely flammable, and its vapors can cause an explosion if ignited. **DO NOT** start the engine near spilled fuel or combustible fluids.



**DO NOT** fill the fuel tank while the engine is running or hot. **DO NOT** overfill tank, since spilled fuel could ignite if it comes into contact with hot engine parts or sparks from the ignition system. Store fuel in approved containers, in well-ventilated areas and away from sparks and flames.

### **WARNING**

#### Burn Hazards

Engine components can generate extreme heat. To prevent burns, **DO NOT** touch these areas while the engine is running or immediately after operations. Never operate the engine with heat shields or heat guards removed.



### **WARNING**

#### Respiratory Hazards

**ALWAYS** wear approved **respiratory** protection when required.



# MT-76D2 TAMPING RAMMER — SAFETY MESSAGE ALERT SYMBOLS

## CAUTION

### Rotating Parts Hazards

**NEVER** operate equipment with covers, or guards removed. Keep fingers, hands, hair and clothing away from all moving parts to prevent injury.



## CAUTION

### Equipment Damage Hazards

Other important messages are provided throughout this manual to help prevent damage to your light tower, other property, or the surrounding environment.

## CAUTION

### Accidental Starting Hazards

**ALWAYS** place the **ON/OFF** switch in the **OFF** position when the rammer is not in use.



## CAUTION

### Eye and Hearing Hazards



**ALWAYS** wear approved eye and hearing protection.

 **WARNING**



**To avoid injury, you MUST read and understand operator's manual before using this machine.**



**This machine to be operated by qualified personnel only. Ask for training as needed.**

PIN 35137

## DANGER

### Refueling Hazard

**NEVER** refuel rammer when placed in truck bed with plastic liner. The possibility exists of explosion due to static electricity. When adding fuel, remove rammer from truck bed and place on ground.

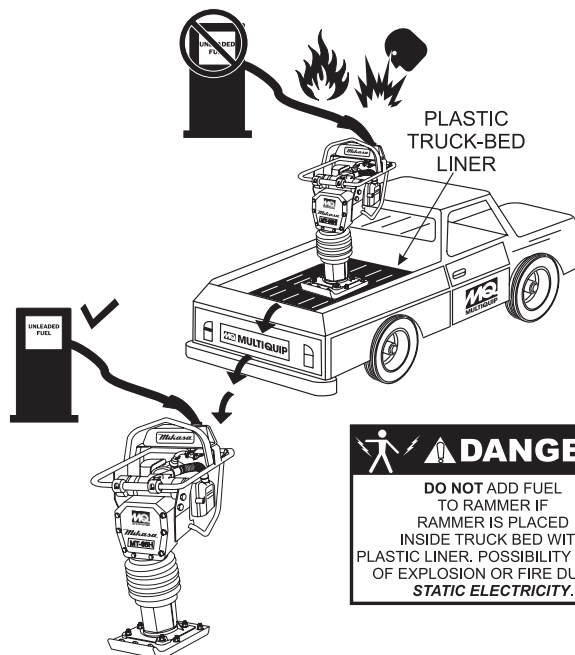

** DANGER**

**DO NOT ADD FUEL TO RAMMER IF RAMMER IS PLACED INSIDE TRUCK BED WITH PLASTIC LINER. POSSIBILITY EXISTS OF EXPLOSION OR FIRE DUE TO STATIC ELECTRICITY.**

# MT-76D2 TAMPING RAMMER — RULES FOR SAFE OPERATION

## DANGER

Read this manual!

Failure to follow instructions in this manual may lead to serious injury or even death! This equipment is to be operated by trained and qualified personnel only! This equipment is for industrial use only.

The following safety guidelines should always be used when operating the MT-76D2 Tamping Rammer:

### GENERAL SAFETY

■ **DO NOT** operate or service this equipment before reading this entire manual.



■ This equipment should not be operated by persons under 18 years of age.

■ **NEVER** operate this equipment without proper protective clothing, shatterproof glasses, steel-toed boots and other protective devices required by the job.



■ **NEVER** operate this equipment when not feeling well due to fatigue, illness or taking medicine.



■ **NEVER** operate this equipment under the influence of **drugs** or **alcohol**.



■ **ALWAYS** wear proper respiratory (mask), hearing and eye protection equipment when operating the rammer.



■ Whenever necessary, replace nameplate, operation and safety decals when they become difficult read.

■ Manufacturer does not assume responsibility for any accident due to equipment modifications.

■ **NEVER** use accessories or attachments, which are not recommended by Multiquip for this equipment. Damage to the equipment and/or injury to user may result.

■ **NEVER** touch the hot exhaust manifold, muffler or cylinder. Allow these parts to cool before servicing engine or rammer.

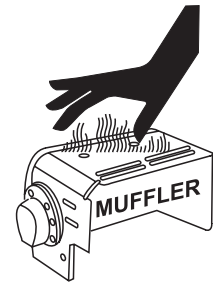

■ **High Temperatures** – Allow the engine to cool before adding fuel or performing service and maintenance functions. Contact with **hot!** components can cause serious burns.

■ The engine section of this rammer requires an adequate free flow of cooling air. **NEVER** operate the rammer in any enclosed or narrow area where free flow of the air is restricted. If the air flow is restricted it will cause serious damage to the rammer or engine and may cause injury to people. Remember the rammer's engine gives off **DEADLY** carbon monoxide gas.

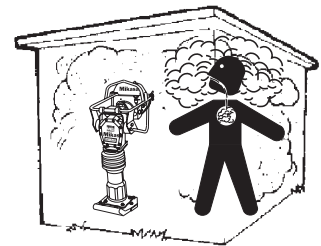

■ **ALWAYS** refuel in a well-ventilated area, away from sparks and open flames.

■ **ALWAYS** use extreme caution when working with **flammable** liquids. When refueling, **stop the engine** and allow it to cool. **DO NOT smoke** around or near the machine. Fire or explosion could result from fuel vapors, or if fuel is spilled on a hot engine.

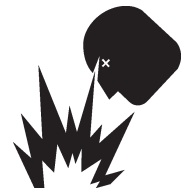

■ **NEVER** operate the rammer in an explosive atmosphere or near combustible materials. An explosion or fire could result causing severe **bodily harm or even death**.

■ **DO NOT smoke** around or near the machine. Fire or explosion could result from fuel vapors, or if fuel is spilled on a hot engine.



■ Topping-off to filler port is dangerous, as it tends to spill fuel.

■ Stop the engine when leaving the rammer unattended.

■ Maintain this equipment in a safe operating condition at all times.

# MT-76D2 TAMPING RAMMER — RULES FOR SAFE OPERATION

- **ALWAYS** stop the engine before servicing, adding fuel and oil.
- **NEVER** run engine without air filter. Severe engine may occur.
- **ALWAYS** service air cleaner frequently to prevent carburetor malfunction.
- **ALWAYS** check the machine for loosened threads or bolts before starting.
- **ALWAYS** be sure the operator is familiar with proper safety precautions and operations techniques before using rammer.
- **ALWAYS** store equipment properly when it is not being used. Equipment should be stored in a clean, dry location out of the reach of children.
- **DO NOT** operate this equipment unless all guards and safety devices are attached and in place.
- **CAUTION** must be exercised while servicing this equipment. Rotating and moving parts can cause injury if contacted.
- Keep all ***inexperienced*** and ***unauthorized*** people away from the equipment at all times.
- Unauthorized equipment modifications will void all warranties.
- **NEVER** pour or spray water over the engine.
- Test the engine **ON/OFF** switch before operating. The purpose of this switch is to shut down the engine of the rammer.
- Refer to the ***Yanmar Engine Owner's Manual*** for engine technical questions or information recommended by Multiquip for this equipment.

## TRANSPORTING

- **ALWAYS** shutdown engine before transporting.
- Tighten fuel tank cap securely and close fuel cock to prevent fuel from spilling.
- Drain fuel when transporting rammer over long distances or bad roads.
- When placing the rammer inside a truck-bed for transport, always tie-down the rammer

## MAINTENANCE

- **NEVER** lubricate components or attempt service on a running rammer.
- **ALWAYS** allow the rammer a proper amount of time to cool before servicing.
- Keep the rammer in proper running condition.
- Fix damage to the rammer immediately and always replace broken parts.
- Dispose of hazardous waste properly. Examples of potentially hazardous waste are used motor oil, fuel and fuel filters.
- **DO NOT** use food or plastic containers to dispose of hazardous waste.

## EMERGENCIES

- **ALWAYS** know the location of the nearest ***fire extinguisher*** and ***first aid kit***.



- In emergencies ***always*** know the location of the nearest phone or ***keep a phone on the job site***. Also know the phone numbers of the nearest ***ambulance***, ***doctor*** and ***fire department***. This information will be invaluable in the case of an emergency.



# MT-76D2 TAMPING RAMMER — OPERATION AND SAFETY DECALS



P/N 920101580



P/N 920203330

**NAMEPLATE**

---



---



---

CONTACT MULTIQUIP  
SERVICE DEPT.

SAE 10W-30  
MOTOR OIL

P/N 920201950

3650 ~ 3850 RPM  
NPA 90

P/N 920205820

**CAUTION !**

- READ OWNER'S SERVICE MANUAL BEFORE OPERATING OR SERVICING THIS MACHINE.
- ALWAYS KEEP UNAUTHORIZED, INEXPERIENCED, UNTRAINED PEOPLE AWAY FROM THIS MACHINE.
- MAKE SURE ALL SAFETY DEVICES ARE OPERATIONAL BEFORE THIS MACHINE IS STARTED. MAKE SURE ENGINE IS TURNED OFF AND SPARK PLUG WIRE DISCONNECTED BEFORE SERVICING THE MACHINE OR COMING IN CONTACT WITH ANY MOVING PART. IF EQUIPMENT IS POWERED BY AN ELECTRIC MOTOR, DISCONNECT ELECTRICAL PLUG.
- NEVER LEAVE MACHINE UNATTENDED WHEN OPERATING. ALWAYS STOP ENGINE AND ALLOW ENGINE TO COOL BEFORE ADDING FUEL OR OIL.

NPA-329 ©

P/N 920203290

**NOTICE**

Clean the element with neutral cleanser solution and rinse it by water. Dry it well before intallation. Cleaning is requested more often in dusty conditions.

NPA-583

**⚠ CAUTION**

1. Before operation of this machine, the designated operator must read and completely understand the operating instruction manual.
2. Operator must wear correct protective clothing (safety glasses, steel toed boots, etc.).
3. Check all nuts, bolts and fasteners, retighten as necessary.
4. Lower unit lubrication must be checked daily (oil level must be at least half way on sight glass).
5. Engine oil must be checked daily (a good quality diesel oil must be used). Do not use gasoline motor oil.
6. These are only 3 positions on the throttle lever: Stop, Idle, and Operating.
7. Starting Engine:
  - A. Place the throttle in the idle position.
  - B. Pull the recoil until a slight resistance is felt.
  - C. Allow recoil to retract. Press the decompression lever to decompress. Pull the recoil firmly and quick.
  - D. Allow the recoil to retract before releasing.
  - E. Engine must be allowed to warm-up approximately five minutes before operating unit.
8. Operating:
  - Place the throttle lever to the operating position.
9. Stop:
  - The engine must be allowed to idle for approximately three minutes before stopping.

NPA-584 ©

Lubrication Oil Recommendations: \_\_\_\_\_ Fuel: \_\_\_\_\_

Lower Unit: SAE CF class or higher 10W30 **Diesel**

Engine: SAE CC class or higher 10W30

P/N 920205840

# MT-76D2 TAMPING RAMMER — GENERAL INFORMATION

## Definition of Tamping Rammer

The Mikasa MT-76D2 tamping rammer is a powerful compacting tool capable of applying a tremendous force in consecutive impacts to a soil surface. Its applications include soil compacting for road, embankments and reservoirs as well as backfilling for gas pipelines, water pipelines and cable installation work.

The impact force of the MT-76D2 levels and uniformly compacts voids between soil particles to increase dry density.

Circular motion is converted to create impact force. The MT-76D2 tamping rammer develops a powerful compacting force at the foot of the rammer. To maintain optimum performance, proper operation and service are essential.

## Construction of Tamping Rammer

The Mikasa MT-76D2 Tamping Rammer is equipped with a Yanmar L48V6 diesel engine. Transmission of the power takes place by increasing the engine speed to engage the centrifugal clutch.

## Rammer Gearbox and Spring Cylinder

The Mikasa MT-76D2 uses an oil bath lubrication system. Always check the oil level through the oil level sight glass at the rear of the tamper foot.

## Controls

Before starting the MT-76D2 Tamping Rammer, identify and understand the function of the controls.

# MT-76D2 TAMPING RAMMER — SPECIFICATIONS

**Table 1. MT-76D2 Rammer Specifications**

MODEL	MT-76D2
Overall Height	39.4 in. (1,000 mm)
Overall Width	16.1 in (410 mm)
Over Length	28.3 in (720 mm)
Shoe Size	11 in. (285 mm)
Blows/minute	700
Impact Force	3,600 lbs./blow (1,623 kg/blow)
Clutch	Automatic Centrifugal
Operating Weight	176 lbs. (80 kg)

**Table 2. Yanmar L-48V6 Engine Specifications**

MODEL	Yanmar L48V6LF9M3ERSCE
Type	Air-Cooled 4 Stroke Diesel Engine
Piston Displacement	13.3 cu. in. ( 219 cc)
Max. Governed Speed, No Load	3,300 rpm
Cooling System	Air-Cooled
Lubrication System	Diesel Engine Lububricating Oil API Classification "CC" or "CD" Grade
Fuel	Automotive Diesel Fuel
Starting System	Recoil Starter

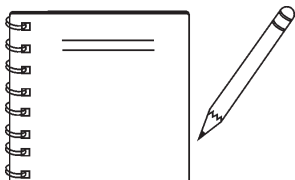

Specifications are general and are subject to change without notice. If exact measurements are required, equipment should be weighed and measured.

# MT-76D2 TAMPING RAMMER — CONTROLS AND COMPONENTS

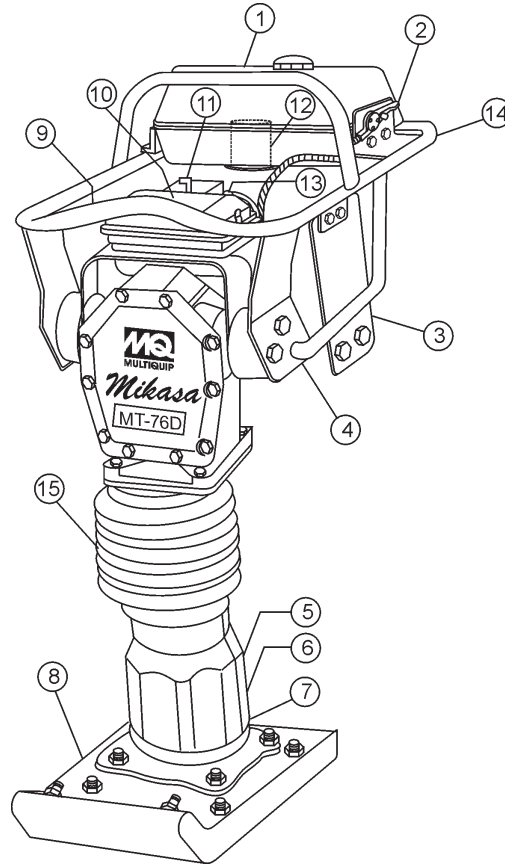

**Figure 1. MT-76D2 Tamping Rammer**

Figure 1 shows the location of the controls and components for the MT-76D2 Tamping Rammer. The functions of each control is described below:

1. **Fuel Tank/Cap** – Remove this cap to add **diesel** fuel. Use high grade automotive diesel fuel only.
2. **Throttle Lever** – Controls engine speed and the tamping action of the rammer.
3. **Engine Oil Dipstick** – Indicates the level of the engine oil. Use CC class or higher grade motor oil.
4. **Oil filter** – Prevents dirt and other debris from entering the engine.
5. **Oil Bath Fill Plug** – Open this plug to add oil to the oil bath reservoir.
6. **Oil Level Sight Glass** – Indicates the level of oil in the oil bath reservoir.
7. **Drain Valve** – Open this valve to remove oil from the bellows.
8. **Foot** – Laminated wood with tempered steel plate for superior shock absorption.
9. **Muffler** – Used to reduce noise and emissions.
10. **Engine Air Cleaner** – Prevents dirt and other debris from entering the engine.
11. **Decompression Lever** – Use in the starting of the engine. Press lever to engage. After engine starts lever will return to original position.
12. **Fuel Filter** – Located inside fuel tank. Prevents dirt and debris from entering fuel system.
13. **Recoil Starting Handle** – Used when starting the engine. Pull starter handle sharply and quickly, then return starter handle to starter case before releasing.
14. **Handle** – To operate rammer **GRIP** handle assembly firmly on both sides.
15. **Bellows** – Reservoir for oil bath.

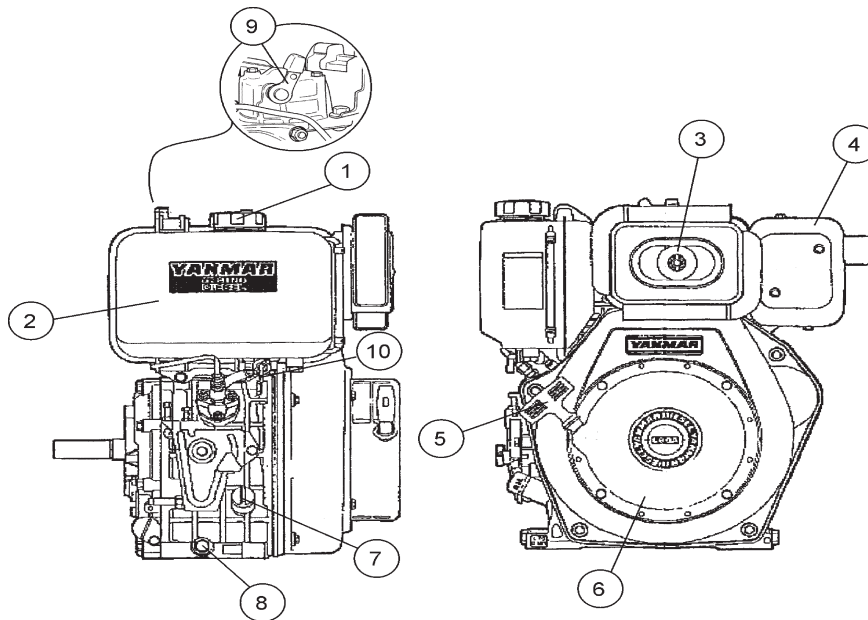

**Figure 2. Engine Controls and Components**

The engine shown above is a **YANMAR L48V6** engine (Figure 2). The engine must be checked for proper lubrication and filled with fuel prior to operation. Refer to the manufacturer's engine manual for instructions and details of operation and servicing. Each component is described below:

- 1. Fuel Filler Cap** – Remove this cap to add unleaded gasoline to the fuel tank. Make sure cap is tightened securely. **DO NOT** over fill.

### CAUTION - Fueling The Engine

Adding fuel to the tank should be done only when the engine is stopped and has had an opportunity to cool down. In the event of a fuel spill, **DO NOT** attempt to start the engine until the fuel residue has been completely wiped up, and the area surrounding the engine is dry.

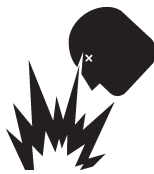

- 2. Fuel Tank** – Capacity is 3.5 quarts (3.31 liters) of diesel fuel.
- 3. Air Cleaner** – Prevents dirt and other debris from entering the fuel system. Remove wing-nut on top of air filter canister to gain access to filter element.
- 4. Muffler** – Used to reduce noise and emissions.
- 5. Recoil Starting Handle (pull rope)** – Type of engine starting method.

- 6. Recoil Starter**– Manual-starting method. Pull the starter grip until resistance is felt, then pull briskly and smoothly.
- 7. Oil Filler Cap / Dipstick** – Remove this cap to add oil to the engine crankcase. Read dipstick to determine if oil level is low. **DO NOT** over fill.

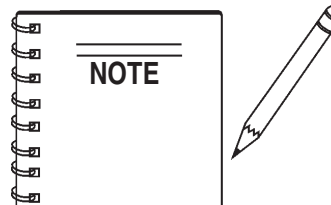

Operating the engine without an air filter, with a damaged air filter, or a filter in need of replacement will allow dirt to enter the engine, causing rapid engine wear.

- 8. Oil Drain Plug** – Unscrew plug to drain oil from engine crankcase. Dispose of oil in a safe manner.
- 9. Decompression Lever**– Press down before starting engine. To prevent damage to engine, **DO NOT** use for any other purpose.

### CAUTION - Burn Hazard

Engine components can generate extreme heat. To prevent burns, **DO NOT** touch these areas while the engine is running or immediately after operating. **NEVER** operate the engine with the muffler removed.



- 10. Fuel Cock**– Controls the flow of diesel fuel to the carburetor. Must be in the ON position when starting and running the engine.

# MT-76D2 TAMPING RAMMER — INITIAL START-UP

This section is intended to assist the operator with the initial start-up of the MT-76D2 Tamping Rammer. It is extremely important that this section be read carefully before attempting to operate the rammer.

**DO NOT** use your rammer until this section is thoroughly understood.

 <b>CAUTION</b>	<b>Read Manual</b>
Failure to understand the operation of the MT-76D2 Tamping Rammer could result in severe damage to the rammer or cause personal injury.	

## Rammer Gearbox and Spring Cylinder

This unit uses an oil bath lubrication system. Check oil level through oil level sight glass at rear of tamper foot. If oil is not visible, add #10W-30 motor oil. Oil bath contains approx. 1.7 pt. (800cc).

### Engine

1. Fill the fuel tank with automobile diesel fuel (See Figure 3).

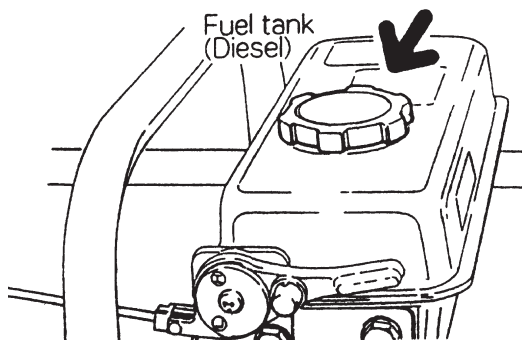

**Figure 3. Fuel Tank**

2. For checking the oil level, move the engine to vertical position and check that the oil is level with the oil inlet (about 700cc). See Figure 4.

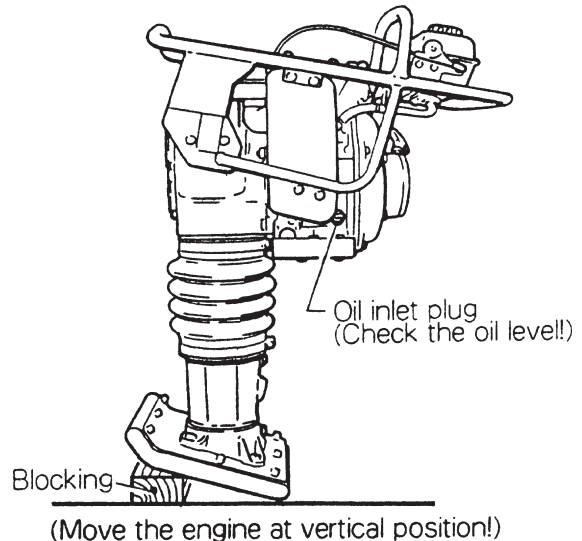

**Figure 4. Oil Level**

### INSPECTION

1. Check all nuts, bolts and fasteners for tightness. Retighten as necessary.
2. Clean dirt from the recoil starter and foot. Wipe entire unit clean before operating.
3. Replace any missing or damaged Safety/Operation decals.

# MT-76D2 TAMPING RAMMER — INITIAL START-UP

## 4. Starting

1. Move the throttle lever to IDLE position. (See Figure 5).

Throttle lever is used only at three (STOP, IDLE & OPERATION) positions. When moving the lever from stop to idle position, press button on lever at same time it is moved.

In cold weather, the engine should be started at operating position or between the idle and operation position of the throttle lever. Use caution as higher engine RPM may engage clutch, when engine starts. Return throttle lever from starting position to idle position when engine starts.

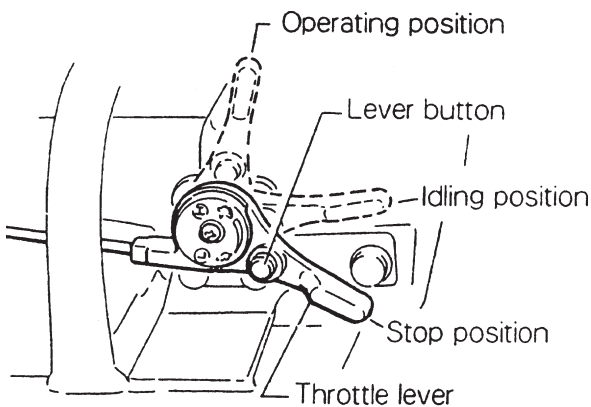

**Figure 5. Throttle Lever**

2. Grip the recoil starter handle and pull it until you feel a slight resistance. (See Figure 6).

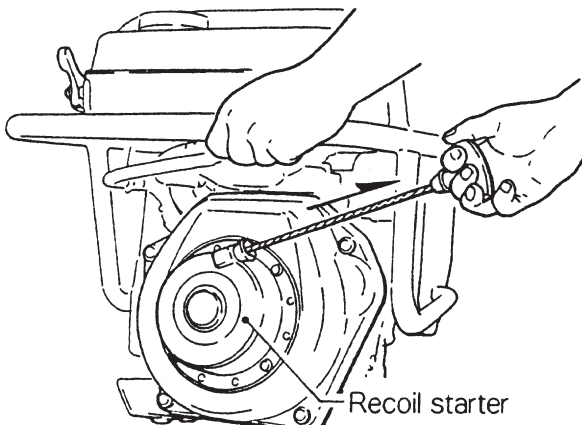

**Figure 6. Recoil Starter**

3. Press the decompression lever to release decompression. The decompression lever will return automatically when the recoil starter is pulled. (See Figure 7).

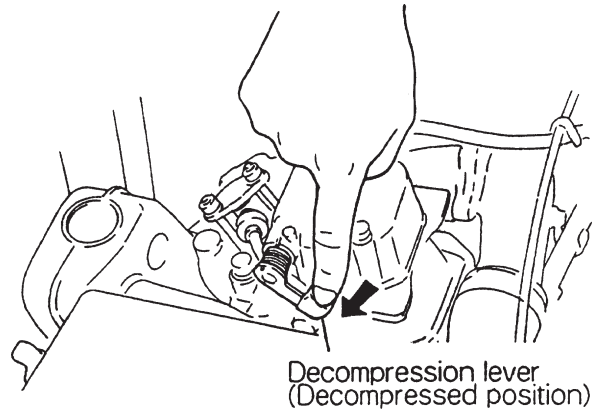

**Figure 7. Decompression Lever**

4. Return the recoil starter, and pull the handle sharply and quickly. Warm up the engine by running at low speed for three to five minutes, while checking for fuel leakage or abnormal sounds.

### **CAUTION**

Do not pull the starter rope all the way to the end and do not let the starter rope snap back as damage may result.

## Operation

1. Move the throttle lever quickly from the IDLE to OPERATION position to start tamping action. DO NOT move the throttle lever slowly as this may cause damage to the clutch or spring box.

## CAUTION

The tamping rammer is designed to tamp the ground 700 times per minute at an engine speed of 3,300 rpm. Increasing the engine speed above the recommended rpm will not increase the rammer effectiveness. Impact will actually decrease because a resonance is created rather than a tamping effect, and damage to the unit can result.

2. The rammer can be warmed by quickly moving the throttle lever from the OPERATION to the IDLE position several times until the rammer operates smoothly.
3. The tamping rammer is designed to travel forward while tamping. To increase travel speed, pull back slightly on the handle so that the rear of the foot contacts the soil first.
4. To stop tamping, quickly move the throttle lever from the OPERATION to IDLE position. Do not move the lever slowly as irregular action and damage may result.

## Stopping the Engine

1. Move throttle lever quickly from idle to STOP while pressing the throttle lever button. Run the engine for three minutes at idle speed to allow for proper cool down. Following the above procedures will prevent improper cylinder lubrication caused by a overheated engine. See Figure 8.

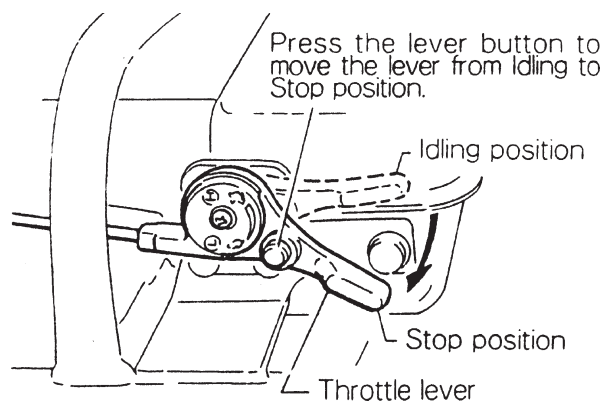

**Figure 8. Stopping the Engine**

# MT-76D2 TAMPING RAMMER — MAINTENANCE

## MAINTENANCE

Perform the scheduled maintenance procedures as indicated:

### Daily

- Thoroughly remove dirt and oil from the engine and control area.
- Clean or replaces air cleaner as necessary.
- Check and retighten all fasteners as necessary.
- Check spring box and bellows for oil leaks. Repair as needed.
- Remove element from pre-cleaner at the top of crankcase (body side) and clean it by air.

### Weekly (every 50 hours)

- Remove the fuel filter cap and inspect for dirt in the fuel tank. See Figure 9.

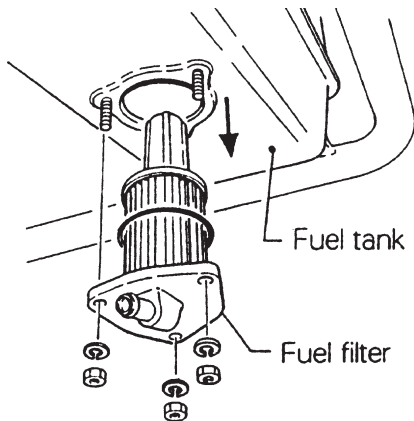

**Figure 9. Removing Fuel Filter Cap**

### Replacement of Lubricant (Body)

- Remove the drain plug at the rear of tamper foot and drain the dirty oil. Refill with clean oil to the middle of the sight glass. Oil bath contains approx. 1.7 pt. (800 cc).

#### INITIAL OIL CHANGE:

After 50 hours of operation.

#### SECOND OIL CHANGE AND/OR LATER

Every 200 hours of operation.

### Replacement of Lubricant (ENGINE)

1. While the engine is still warm, remove the drain plug. For quick discharging, it is advisable to take off the oil gauge. Replace drain plug and refill engine crankcase. See Figure 10.

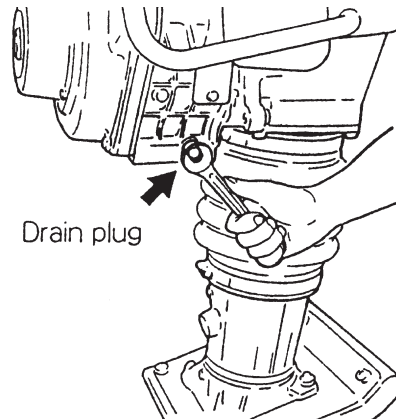

**Figure 10. Replacement of Lubricant**

2. Refer to Table 3 for oil types. Inferior quality engine oil and/or lack of oil may cause engine trouble or shorten engine life.

Table 3 Motor Oil Grade		
Temperature	Grade of Motor Oil	
68° F and Above	CC Class or higher grade	SAE 30
+14° F to +68° F		SAE 20
Below +14° F		SAE 10W-30

### Engine Oil Replacement Interval

#### INITIAL OIL CHANGE:

After 20 hours of operation.

#### SECOND OIL CHANGE AND/OR LATER:

Every 100 hours of operation.

# MT-76D2 TAMPING RAMMER — MAINTENANCE

## Cleaning the Air Cleaner

Clean the Air Cleaner every 200-300 hours. See Figure 11.

- Remove element from pre-cleaner at the top of crankcase (body side).
- Wash the element (outside) in detergent solution.
- Shake out excess moisture and dry the element.
- Clean inside element with air from the inside of element.

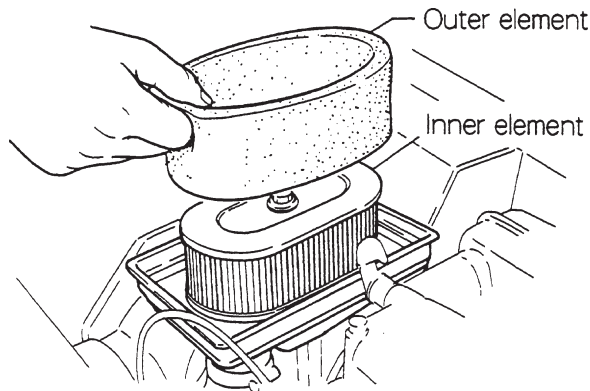

**Figure 11. Air Cleaner**

## Cleaning the Oil Filter

Drain oil filter every 100 hours of operation. Replace the oil filter every 1,000 hours of operation. See Figure 12.

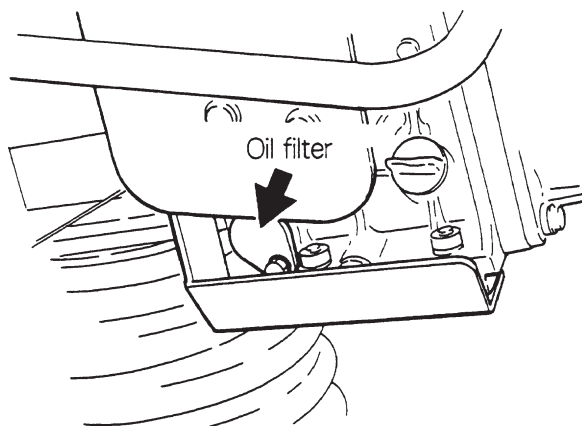

**Figure 12. Oil Filter**

## Fuel Pipe & Oil Pipe

- Check fuel line regularly for damage, paying attention to clamps to assure a tight fit.
- Replace fuel line every two years to maintain original performance.

## Transportation

Maintain upright position of rammer at all times. Transport rammer in upright position. If machine must be laid down for transportation, drain the diesel fuel first and lay machine with muffler side down. See Figure 13.

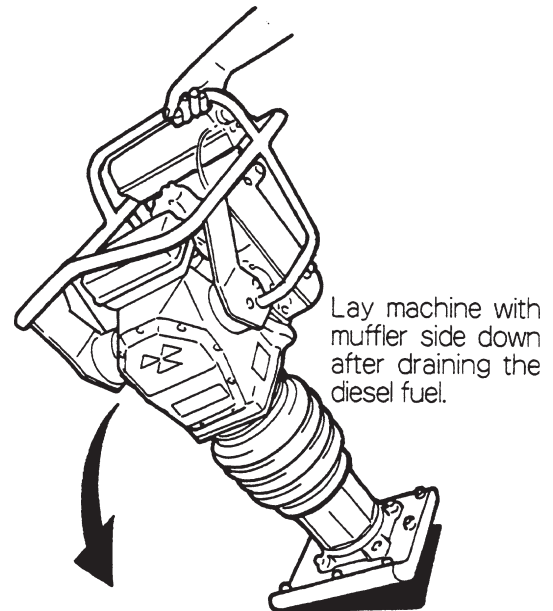

**Figure 13. Transporting Rammer**

The fuel filter is installed at the bottom of fuel tank. Should the rammer be laid on its side, dirt from the fuel filter may contaminate the injection nozzle, causing damage to the fuel pump.

## Storage

- When storing the rammer for long periods of time, thoroughly drain all fuel from line.
- Clean exterior of rammer with an oil moistened cloth. Cover and store in a clean, dry place.

# MT-76D2 TAMPING RAMMER — TROUBLESHOOTING

**TABLE 4. ENGINE TROUBLESHOOTING**

SYMPTOM	POSSIBLE PROBLEM	SOLUTION
Engine will not start or start is delayed, although engine can be turned over.	Speed control lever is in "STOP" position?	Set speed control lever to "START" position.
	No fuel reaching injection pump?	Add fuel. Check entire fuel system.
	Defective fuel pump?	Replace fuel pump.
	Fuel filter clogged?	Replace fuel filter and clean tank.
	Faulty fuel supply line?	Replace or repair fuel line.
	Compression too low?	Check piston, cylinder and valves. Adjust or repair per engine repair manual.
	Fuel injector not working correctly?	Repair or replace injector in accordance with engine repair manual.
	Oil pressure too low?	Check engine oil pressure.
	Low starting temperature limit exceeded	Comply with cold starting instructions and proper oil viscosity.
At low temperatures engine will not start.	Fuel separates has inadequate resistance to low temperatures?	Check whether clear (not turbid) fuel emerges from the fuel line (detach from injection pump). If the fuel is turbid or separated, warm up the engine or drain the complete fuel supply system. Refuel with winter grade diesel fuel.
	Engine oil too thick?	Refill engine crankcase with correct type of oil for winter environment.
Engine fires but stops soon as starter is switched off.	Fuel filter blocked?	Replace fuel filter.
	Fuel supply blocked?	Check the entire fuel system.
Engine stops by itself during normal operation.	Fuel tank empty?	Add fuel.
	Fuel filter blocked?	Replace fuel filter.
Low engine power, output and speed.	Fuel tank empty?	Fill with No.2 diesel fuel.
	Fuel filter clogged?	Replace fuel filter.
	Fuel tank venting is inadequate?	Ensure that tank is adequately vented.
	Speed control lever does not remain in selected position?	See engine manual for corrective action.
	Engine oil level too full?	Correct engine oil level?
Low engine power output and low speed, black exhaust smoke.	Air filter blocked?	Clean or replace air filter.
	Incorrect valve clearances?	Adjust valves per engine specification.
	Malfunction at injector?	See engine manual.

# MT-76D2 TAMPING RAMMER — TROUBLESHOOTING

TABLE 5. RAMMER TROUBLESHOOTING

SYMPTOM	POSSIBLE PROBLEM	SOLUTION
Engine rotates but amplitude not uniform or does not strike.	Operating speed of throttle lever is incorrectly set?	Set throttle lever to correct position.
	Oil in excess?	Drain excess oil. Bring to correct level.
	Clutch slips?	Replace or adjust clutch.
	Spring Failure?	Replace sprial spring.
	Speed of engine improper?	Adjust engine speed to correct operating RPM setting.

# MT-76D2 TAMPING RAMMER — EXPLANATION OF PARTS SECTION

The following section explains the different symbols and remarks used in the Parts section of this manual. Use the help numbers found on the back page of the manual if there are any questions.

The contents and part numbers listed in the parts section are subject to change **without notice**. Multiquip does not guarantee the availability of the parts listed.

Sample Parts List:

NO.	PART NO.	PART NAME	QTY.	REMARKS
1	12345	BOLT .....	1 ...	INCLUDES ITEMS W/*
2*		WASHER, 1/4 IN. ....		NOT SOLD SEPARATELY
2*	12347	WASHER, 3/8 IN. ....	1 ...	MQ-45T ONLY
3	12348	HOSE .....	A/R ..	MAKE LOCALLY
4	12349	BEARING .....	1 ....	S/N 2345B AND ABOVE

## NO. Column

**Unique Symbols** - All items with same unique symbol (\*, #, +, %, or >) in the number column belong to the same assembly or kit, which is indicated by a note in the “Remarks” column.

**Duplicate Item Numbers** - Duplicate numbers indicate multiple part numbers are in effect for the same general item, such as different size saw blade guards in use or a part that has been updated on newer versions of the same machine.

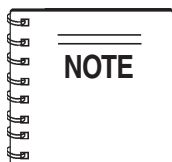

When ordering a part that has more than one item number listed, check the remarks column for help in determining the proper part to order.

## PART NO. Column

**Numbers Used** - Part numbers can be indicated by a number, a blank entry, or TBD.

TBD (To Be Determined) is generally used to show a part that has not been assigned a formal part number at time of publication.

A blank entry generally indicates that the item is not sold separately or is not sold by Multiquip. Other entries will be clarified in the “Remarks” Column.

## QTY. Column

**Numbers Used** - Item quantity can be indicated by a number, a blank entry, or A/R.

A/R (As Required) is generally used for hoses or other parts that are sold in bulk and cut to length.

A blank entry generally indicates that the item is not sold separately. Other entries will be clarified in the “Remarks” Column.

## REMARKS Column

Some of the most common notes found in the “Remarks” Column are listed below. Other additional notes needed to describe the item can also be shown.

**Assembly/Kit** - All items on the parts list with the same unique symbol will be included when this item is purchased.

Indicated by:

“INCLUDES ITEMS W/(unique symbol)”

**Serial Number Break** - Used to list an effective serial number range where a particular part is used.

Indicated by:

“S/N XXXXX AND BELOW”

“S/N XXXX AND ABOVE”

“S/N XXXX TO S/N XXX”

**Specific Model Number Use** - Indicates that the part is used only with the specific model number or model number variant listed. It can also be used to show a part is NOT used on a specific model or model number variant.

Indicated by:

“XXXXX ONLY”

“NOT USED ON XXXX”

**“Make/Obtain Locally”** - Indicates that the part can be purchased at any hardware shop or made out of available items. Examples include battery cables, shims, and certain washers and nuts.

**“Not Sold Separately”** - Indicates that an item cannot be purchased as a separate item and is either part of an assembly/kit that can be purchased, or is not available for sale through Multiquip.

# MT-76D2 TAMPING RAMMER — SUGGESTED SPARE PARTS

## **MT-76D2 RAMMER with Yanmar L48V6 Engine** **1-3 UNITS**

- 1 .... 956100057 ..... THROTTLE WIRE
- 3 .... 371010060 ..... ELEMENT ASSY
- 3 .... 954406010 ..... STRAINER, FUEL TANK
- 2 .... 18325455120 ..... STRAINER ASSY, FUEL
- 1 .... 0430430015 ..... CAP, FUEL TANK
- 1 .... 11429901760 ..... CAP, W/LUB OIL GA.
- 2 .... 11429935110 ..... LUB. OIL FILTER COMPLETE
- 2 .... 24341000224 ..... O-RING, OIL LUB. STRAINER

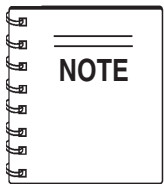

Part numbers on this Suggested Spare Parts List may supersede/replace the P/N shown in the text pages of this book.

# MT-76D2 TAMPING RAMMER — NAME PLATE AND DECALS

## NAME PLATE AND DECALS

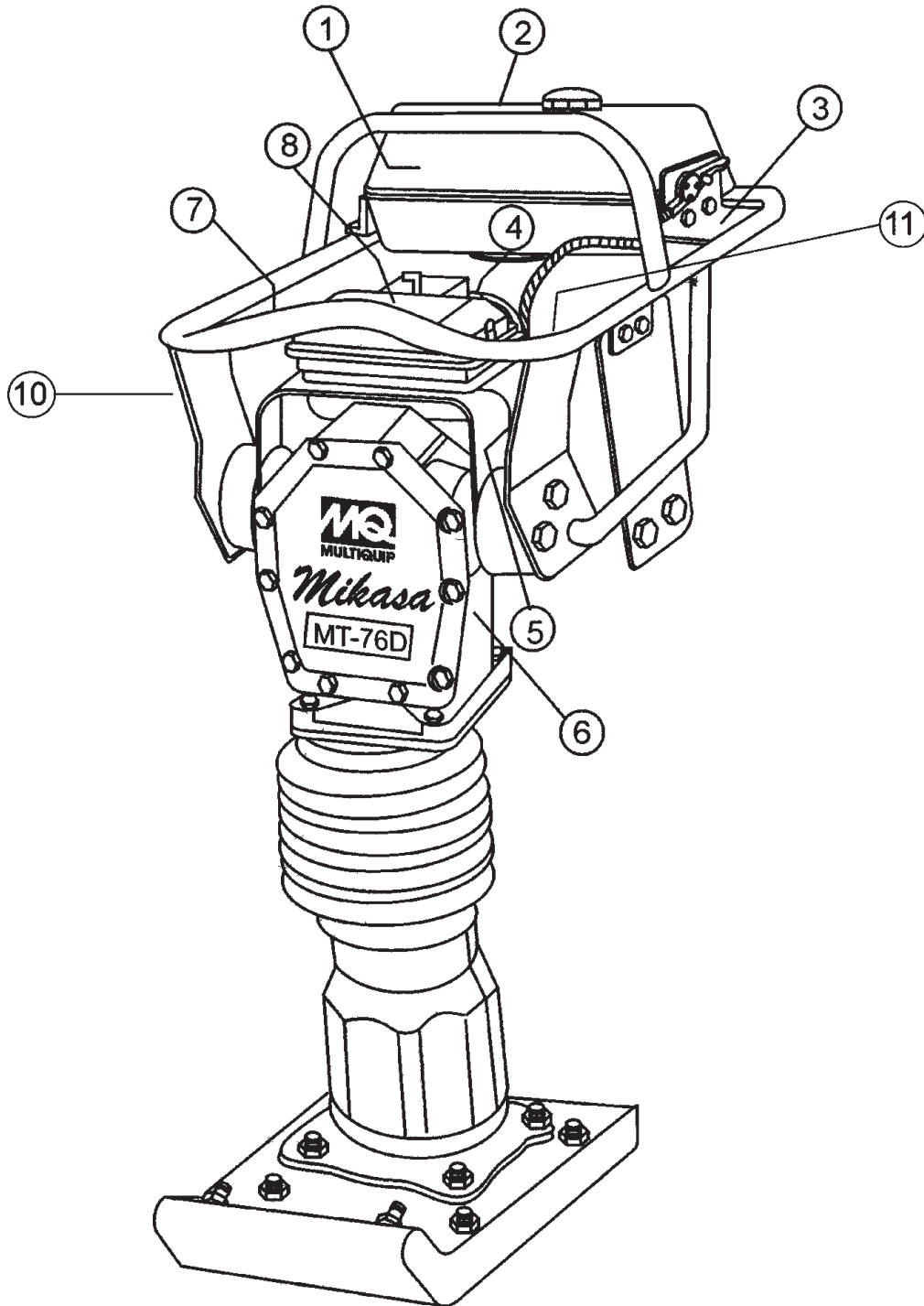

# MT-76D2 TAMPING RAMMER — NAMEPLATE AND DECALS

## NAME PLATE AND DECALS

<u>NO.</u>	<u>PART NO.</u>	<u>PART NAME</u>	<u>QTY.</u>	<u>REMARKS</u>
1*	920101580	DECAL: MIKASA MARK	1	
2*	920205840	DECAL: FUEL DIESEL .....	1	NPA-584
3*	920203330	DECAL: EAR PROTECTION .....	1	NPA-333
4*	920205820	DECAL ENGINE R.P.M 3100-3300	1	
5*	920203290	DECAL: READ OWNER'S MANUAL .....	1	NPA-329
6		NAMEPLATE .....	1	CONTACT MQ PARTS DEPT.
7*	920201950	DECAL: MOTOR OIL	1	
8*	920205830	DECAL, AIR CLEANER .....	1	NPA-583
9	DCL86D/76D	DECAL KIT, MT-86D/MT-76D .....	1	INCLUDES ITEMS W*
10	920209100	DECAL: CAUTION	1	
11	920109360	DECAL: DO NOT LAY DOWN	1	

# MT-76D2 TAMPING RAMMER — CRANK CASE AND ENGINE ASSY.

CRANKCASE AND ENGINE ASSY.

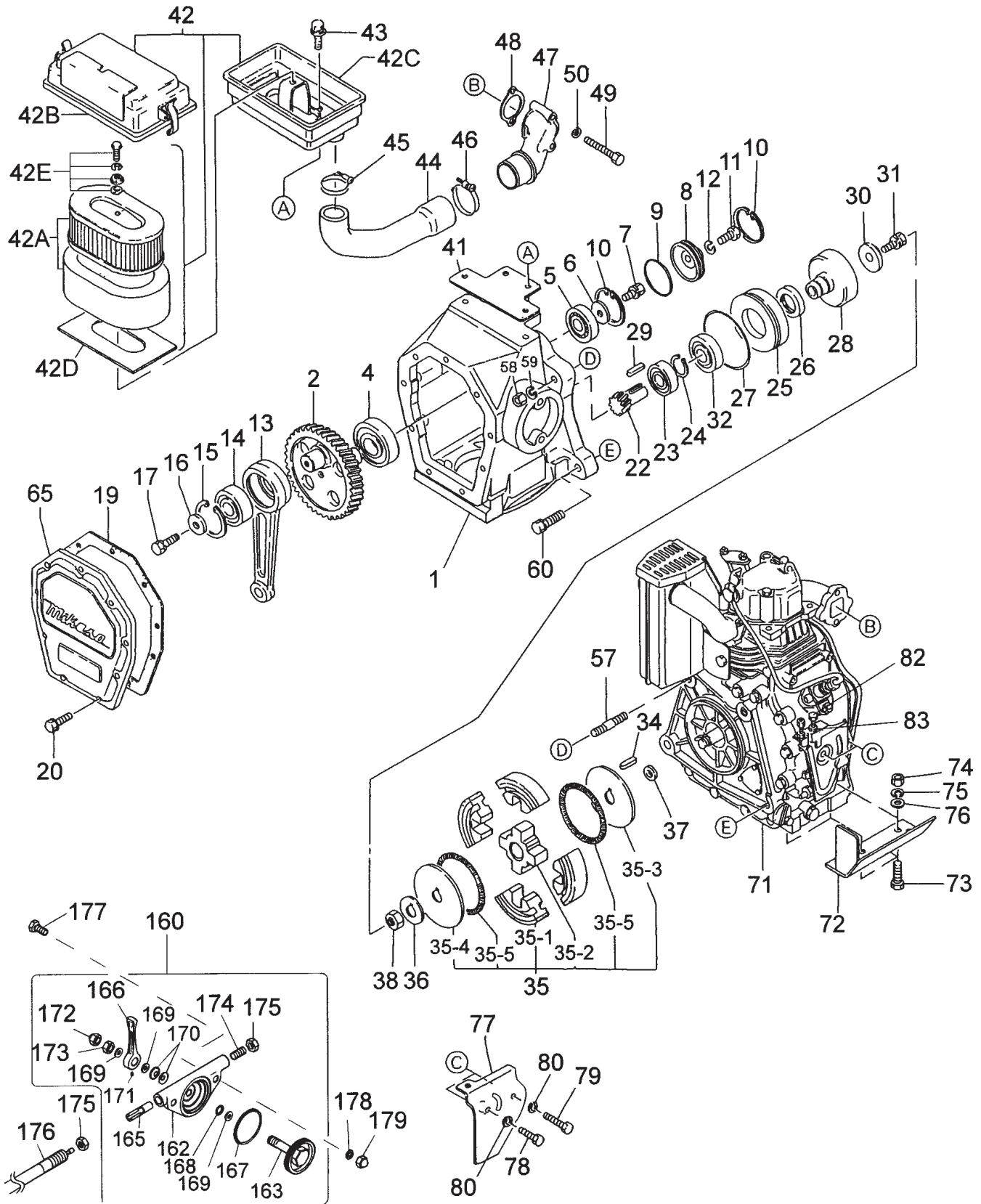

# MT-76D2 TAMPING RAMMER — CRANK CASE AND ENGINE ASSY.

## CRANKCASE AND ENGINE ASSY.

<u>NO.</u>	<u>PART NO.</u>	<u>PART NAME</u>	<u>QTY.</u>	<u>REMARKS</u>
1	371113331	CRANKCASE	1	
2	371334400	CRANK GEAR	1	
4	040006207	BEARING 6207	1	
5	040006204	BEARING 6204	1	
6	952400130	WASHER 9304	1	
7	011708025	BOLT 8X25H, SW .....	1	REPLACES 002210825
8	371447650	BEARING COVER	1	
9	050300480	O-RING S-48	1	
10	080100480	STOP RING R-48	2	
11	001210610	BOLT 6X10H	1	
12	031106100	WASHER PW M6	1	
13	371334730	CONNECTING ROD	1	
14	040006304	BEARING 6304	1	
15	080100520	STOP RING R-52	1	
16	952400130	WASHER 9304	1	
17	011708025	BOLT 8X25H, SW .....	1	REPLACES 002210825
19	352444450	PACKING, FRONT COVER	1	
20	011706020	BOLT 6X20H, SW .....	9	REPLACES 002210620
22	371447620	PINION	1	
23	040006204	BEARING 6204	1	
24	080200350	STOP RING S-35	1	
25	371449600	SPACER .....	1	REPLACES 371335280
26	060404010	OIL SEAL TC-40528	1	
27	050101000	O-RING G-100	1	
28	371447640	CLUTCH DRUM	1	
29	952405610	KEY 5X5X19R	1	
30	952405490	LOCK WASHER	1	
31	002210820	BOLT 8X20H, SW	1	
32	041006007	BEARING 6007Z	1	
34	22512040120	KEY 4X12	1	
35	371447632	CLUTCH ASSY. ....	1	INCLS. ALL ITEMS W/*
35-1*	943020060	CLUTCH SHOE (4)	1	
35-2*	943950050	CLUTCH BOSS	1	
35-3*	943060100	CLUTCH GUIDE (A)	1	
35-4*	943060020	CLUTCH GUIDE (B)	1	
35-5*	943030021	CLUTCH SPRING	2	
36	301010210	LOCK WASHER, CLUTCH	1	
37	371448260	SPACER 15X24X4	1	
38	022910170	NUT M12	1	
41	371448220	PACKING, AIR CLEANER	1	
42	371213392	AIR CLEANER ASSY .....	1	INCLS. ALL ITEMS W/#
42A#	371010060	ELEMENT ASSY	1	
42B#	371010030	BODY ASSY	1	
42C#	371010042	BACK PLATE	1	
42D#	371010050	SEAT, AIR CLEANER	1	
42E#	371010070	BOLT ASSY.	1	
43	002200820	BOLT 8X20H, SW	4	

# MT-76D2 TAMPING RAMMER — CRANKCASE AND ENGINE ASSY.

## CRANKCASE AND ENGINE ASSY.

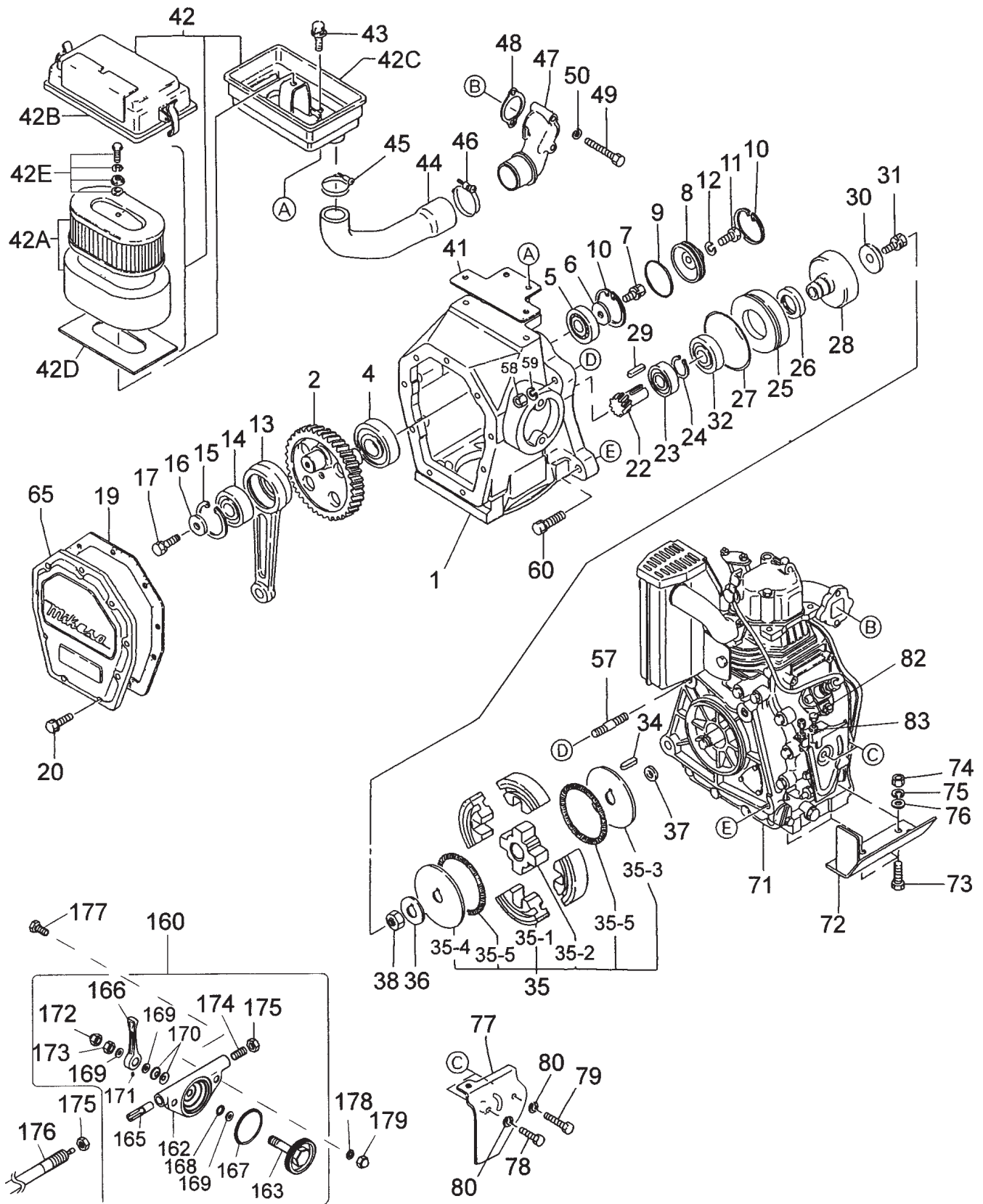

# MT-76D2 TAMPING RAMMER — CRANKCASE AND ENGINE ASSY.

## CRANKCASE AND ENGINE ASSY.

<u>NO.</u>	<u>PART NO.</u>	<u>PART NAME</u>	<u>QTY.</u>	<u>REMARKS</u>
44	371335110	INTAKE PIPE	1	
45	371000010	HOSE BAND (B)	1	
46	371000020	HOSE BAND (B)	1	
47	371335270	INTAKE FLANGE	1	
48	11428412200	GASKET, AIR INTAKE	1	
49	001200652	BOLT 6X60	2	
50	030206150	WASHER SW M6	2	
52	956200040	THROTTLE LEVER ASSY	1	
53	956108040	THROTTLE WIRE	1	
54	371448000	LEVER STAY	1	
56	371448300	CLIP (M)	1	
57	26226100402	STUD M10X20 PLATED	2	
58	020310080	NUT M10	2	
59	030210250	WASHER, LOCK M10	2	
60	002211050	BOLT 10X50H, LOCK	2	
65	371010020	FRONT COVER	1	
71	914410025	ENGINE ASSY L48V6	1	
72	371335100	UNDER PROTECTOR	1	
73	001211040	BOLT 10X40 H	2	
74	020310080	NUT M10	2	
75	030210250	WASHER, LOCK M10	2	
76	031110160	WASHER, FLAT M10	1	
77	371448021	LINK PROTECTOR	1	
78	001200630	BOLT 6X30	1	
79	001200635	BOLT 6X35	1	
80	030206150	WASHER, LOCK M6	2	
81	16026078700	CLAMP WIRE	2	
82	11425066440	BOLT, ADJUSTING	2	
83	26756060002	LOCK NUT M6 PLATED	2	
160	362910060	THROTTLE LEVER ASSY	1	
162	362341550	THROTTLE BODY	1	
163	362910090	THROTTLE GEAR CP W/ BOLT	1	
165	362455620	SLIDER	1	
166	362455630	THROTTLE LEVER	1	
167	050100450	O-RING G-45	1	
168	050200100	O-RING P-10	1	
169	031110160	WASHER, FLAT M10	3	
170	032110180	CONICAL SPRING WASHER M10	2	
171	096206006	SOCKET HEAD SCREW 6X6	1	
172	022131008	CAP NUT M10	1	
173	020410060	NUT M10 ,H=6	1	
174	096208020	SOCKET HEAD SCREW 8X20	1	
175	020408050	NUT M8, H=5	2	
176	956100057	THROTTLE WIRE V390-510	1	
177	001220620	BOLT 6X20 T	2	
178	030206150	WASHER, LOCK M6	2	
179	022130605	CAP NUT M6	2	

# MT-76D2 TAMPING RAMMER — CYLINDER GUIDE AND FOOT ASSY.

CYLINDER GUIDE AND FOOT ASSY.

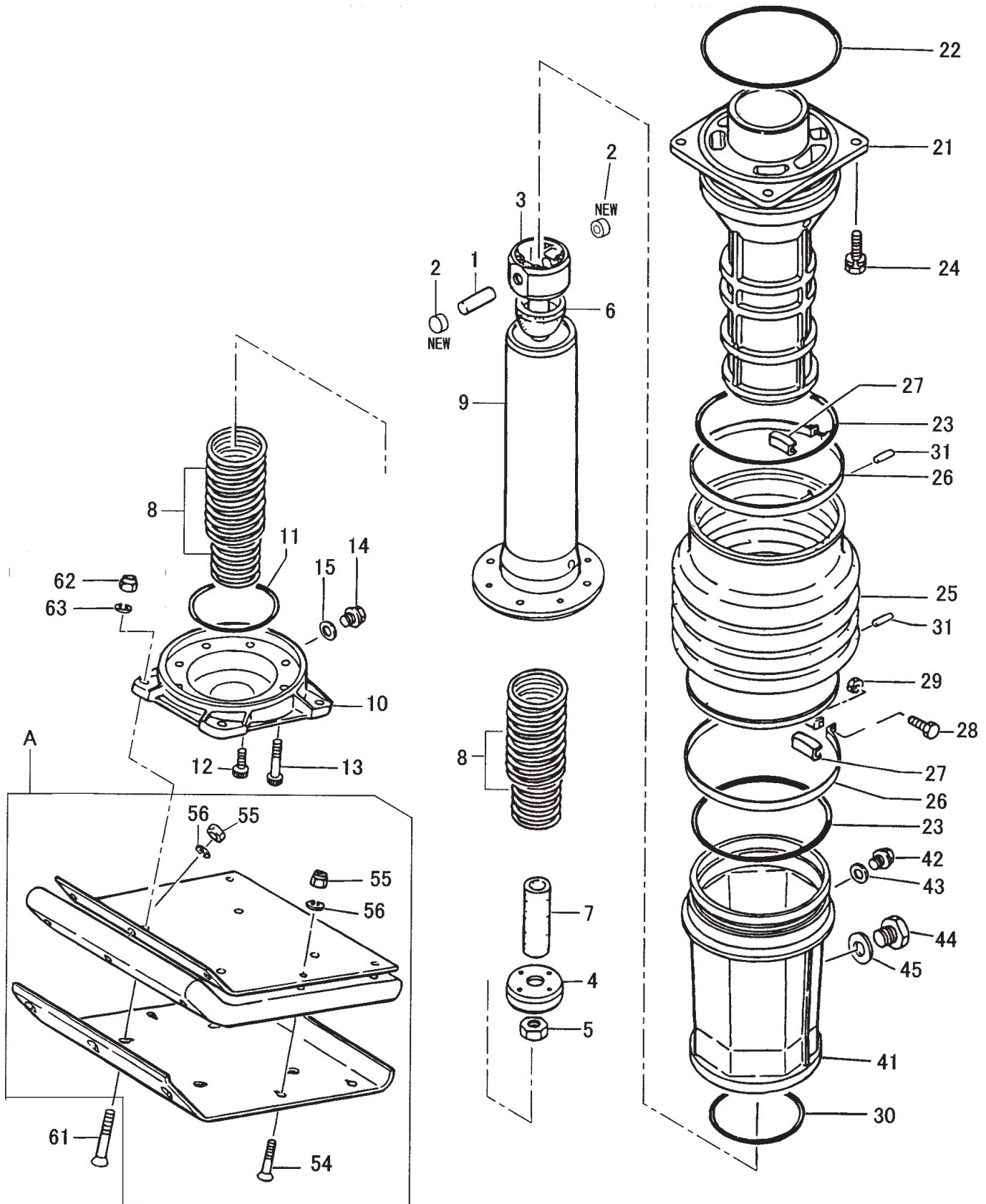

# MT-76D2 TAMPING RAMMER — CYLINDER GUIDE AND FOOT ASSY.

## CYLINDER GUIDE AND FOOT ASSY.

<u>NO.</u>	<u>PART NO.</u>	<u>PART NAME</u>	<u>QTY.</u>	<u>REMARKS</u>
1	352423290	PISTON PIN	1	
2	363457870	PISTON PIN PLUG	2	
3	361344360	PISTON ROD	1	
4	355452340	PISTON END	1	
5	020118150	NUT M18, P1.5	1	
6	355447250	STOPPER, UPPER	1	
7	355447260	STOPPER, LOWER	1	
8	371335250	MAIN SPRING	2	
9	355334310	SPRING CYLINDER	1	
10	355213000	FOOT PLATE	1	
11	050100900	O-RING G-90	1	
12	014210020	SOCKET HEAD BOLT 10X20T .....	4	REPLACES 001521020
13	014210040	SOCKET HEAD BOLT 10X40T .....	4	REPLACES 001521040
14	953405270	PLUG 1/4X14 13L	1	
15	953405260	PACKING 1/4 (CU)	1	
21	355213010	GUIDE CYLINDER	1	
22	050201500	O-RING P-150	1	
23	050931500	O-RING JAS03150	2	
24	012710035	BOLT 10X35, LOCK .....	4	REPLACES 002211035
25	354010010	BELLOWS, ORANGE	1	
26	354336352	BELLOWS CLAMP	2	
27	354442340	BAND GUIDE, BELLOWS	2	
28	001210840	BOLT 8X40 H	2	
29	020108060	NUT M8 .....	2	REPLACES 020308060
30	050100950	O-RING G-95	1	
31	354446170	PIN 6D-8.5L	2	
41	355113960	PROTECTION SLEEVE	1	
42	953405270	PLUG 1/4X14 13L	1	
43	953405260	PACKING 1/4(CU)	1	
44	959010150	LEVEL GAUGE, PLUG TYPE	1	
45	953404670	COPPER PACKING 17X25.5X1	1	
A	362910130	FOOT ASSY 285W-E/F.COVER .....	1	INCLUDES ITEMS W/*
54*	015110055	SUNK HEAD BOLT 10X55H .....	7	REPLACES 001611051
55*	021110120	NYLON NUT M10 .....	7	REPLACES 002711012
56*	030210250	WASHER SW M10	7	
61	015112060	SUNK HEAD BOLT 12X65H .....	4	REPLACES 001611253
62	021112140	NYLON NUT M12 .....	4	REPLACES 022711214
63	030212300	WASHER SW M12	4	

# MT-76D2 TAMPING RAMMER — TANK AND HANDLE ASSY.

TANK AND HANDLE ASSY.

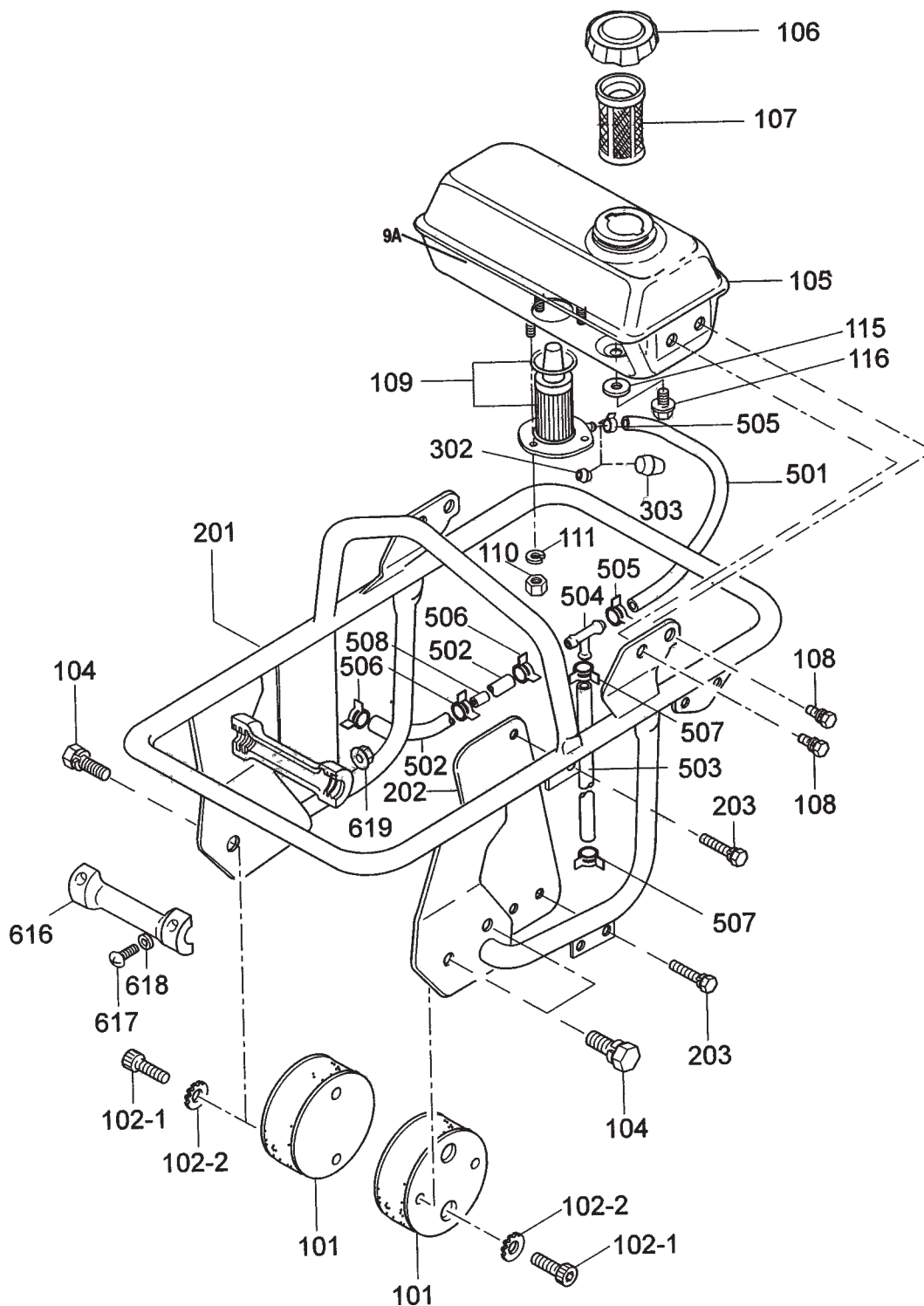

# MT-76D2 TAMPING RAMMER — TANK AND HANDLE ASSY.

## TANK AND HANDLE ASSY.

<u>NO.</u>	<u>PART NO.</u>	<u>PART NAME</u>	<u>QTY.</u>	<u>REMARKS</u>
101	351319900	SHOCK ABSORBER	2	
102-1	014210020	SOCKET HEAD BOLT 10X20T .....	4	REPLACES 001521020
102-2	033121009	TOOTHED LOCK WASHER B M10	4	
104	012210020	BOLT 10X20H, SW .....	4	REPLACES 002211020
105	371118200	FUEL TANK	1	
106	0430430015	FUEL TANK CAP .....	1	REPLACES 953404650
107	954406010	STRAINER (#110)	1	
108	011808015	BOLT 8X15H, SW, PW .....	4	REPLACES 002410815
109	18325455120	STRAINER ASSY, FUEL	1	
110	020106050	NUT M6 .....	3	REPLACES 020306050
111	030206150	WASHER, LOCK M6	3	
115	953405750	PACKING 10.5D-17D-2T	1	
116	953405800	FLANGE PLUG PF1/8	1	
201	371118190	HANDLE	1	
202	371448010	SIDE PROTECTOR	1	
203	011808015	BOLT 8X15H, SW, PW .....	3	REPLACES 002410815
302	953406200	PROTECTION CAP	1	
303	953405740	PLASTIC CAP VC12	1	
501	18366659330	PIPE, FUEL DRAIN	1	
502	18325059050	PIPE, FUEL OIL	1	
503	11465459070	PIPE, FUEL RETURN	1	
504	11428459710	JOINT	1	
505	12476659050	CLAMP 11.5	2	
506	10699044660	BAND HOSE 12.5	3	
507	12472259050	CLAMP 9	2	
508	18325059040	PIECE	1	
616	955200052	ROLLER, W/ PIN	2	
616	955200053	ROLLER, W/ PIN	2	
617	091005025	SCREW 5X25	4	
618	031105080	WASHER, FLAT M5	4	
619	022610505	FLANGE NUT M5 H	4	

# YANMAR L-48V6 ENGINE — CYLINDER BLOCK ASSY.

## CYLINDER BLOCK ASSY.

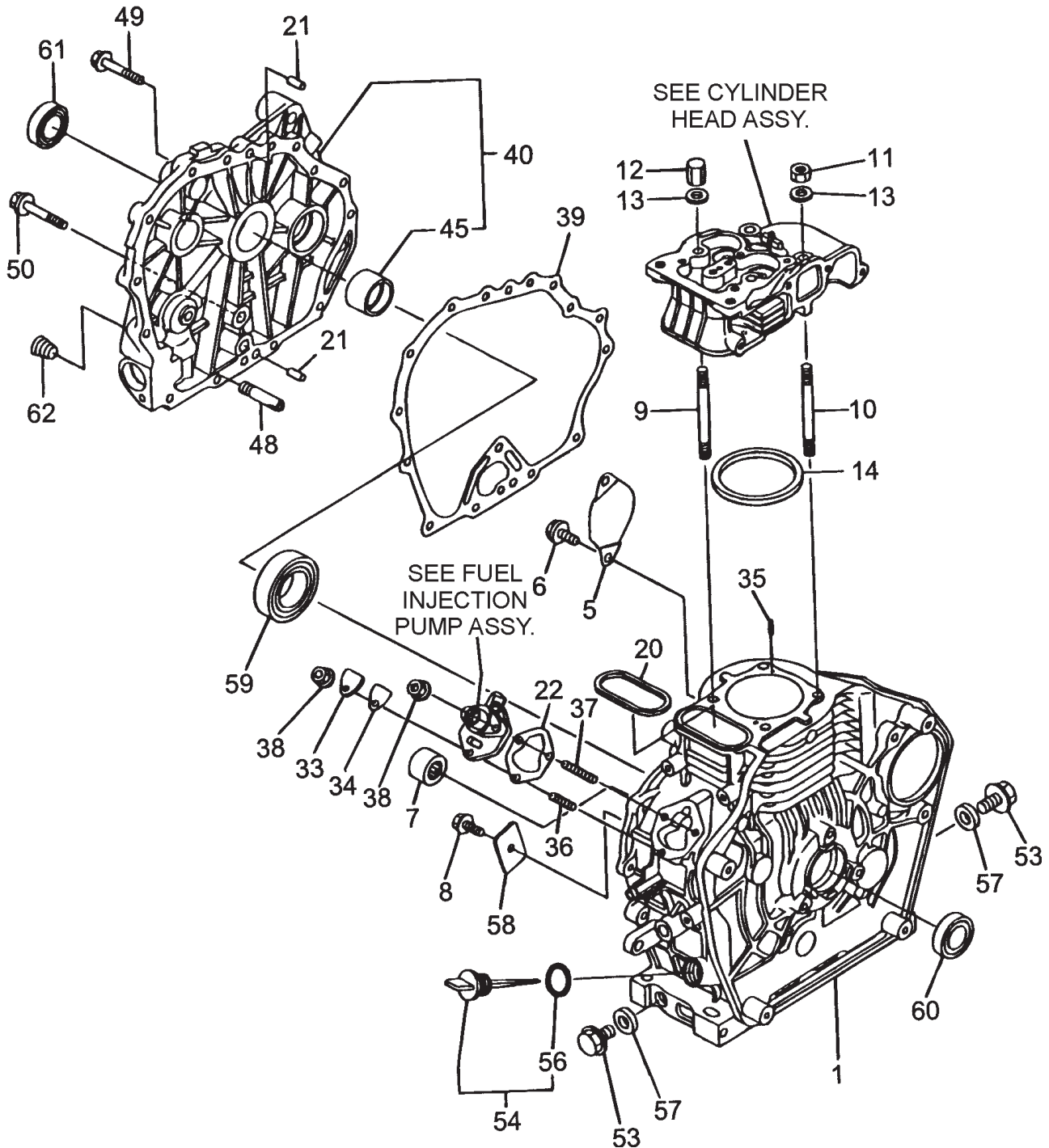

# YANMAR L-48V6 ENGINE — CYLINDER BLOCK ASSY.

## CYLINDER BLOCK ASSY.

<u>NO.</u>	<u>PART NO.</u>	<u>PART NAME</u>	<u>QTY.</u>	<u>REMARKS</u>
1	11429501050	CYLINDER BLOCK ASSY.	1	
5	11439901700	STARTER COVER	1	
6	26106100122	BOLT M10X 12 PLATED	2	
7	24162152112	NEEDLE BEARING	1	
8	26106080122	BOLT M 8X 12 PLATED	1	
9	11429901200	CYLINDER HEAD BOLT A	2	
10	11429901210	CYLINDER HEAD BOLT B	2	
11	11429901220	CYLINDER HEAD NUT A	2	
12	11429901230	CYLINDER HEAD NUT B	2	
13	12495001250	WASHER	4	
14	11429501330	CYLINDER HEAD GASKET ASSY.	1	
20	11429901380	O- RING	1	
21	11429901600	PIN 8X12	2	
22	11429901800	SHIM SET	1	
33	11429901830	COVER, (FO PUMP)	1	
34	11425001841	GASKET	1	
35	22312040080	PIN 4X8 STRAIGHT	2	
36	26226060182	STUD M 6X 18 PLATED	1	
37	26226060222	STUD M 6X 22 PLATED	2	
38	26366060002	NUT M 6	3	
39	11429901410	CRANK CASE GASKET	1	
40	11428401452	DRUM CASE COVER .....	1	INCLUDES ITEMS W/*
45*	11425002100	MAIN BEARING US=STD.	1	
45*	11425002200	BEARING US=0.25, MAIN	1	
45*	11425002210	BEARING US=0.50, MAIN	1	
48	11429935150	L.O. INLET PIPE	1	
49	26106060252	BOLT M 6X 25 PLATED	14	
50	26106080352	BOLT M 8X 35 PLATED	1	
53	11429901690	PLUG M16	2	
54	11429901760	CAP, W/LUBE OIL GAUGE .....	1	INCLUDES ITEMS W/#
56#	11429901950	O- RING	1	
57	22190160002	SEAL WASHER 16S	2	
58	11429902030	RETAINER	1	
59	11425002113	BALL BEARING	1	
60	11429902220	OIL SEAL	1	
61	16021002220	OIL SEAL	1	
62	23876010000	PLUG PT 1/8, SCREW	1	



# YANMAR L-48V6 ENGINE — CYLINDER HEAD ASSY.

## CYLINDER HEAD ASSY.

<u>NO.</u>	<u>PART NO.</u>	<u>PART NAME</u>	<u>QTY.</u>	<u>REMARKS</u>
1	11477111020	CYLINDER HEAD	1	
6	11477111100	SUCTION VALVE	1	
7	11477111110	EXHAUST VALVE	1	
8	11429911120	VALVE SPRING	2	
9	1142511180	SPRING RETAINER	2	
10	27310055001	COTTER	2	
11	22351040008	SPRING PIN 4X8	1	
12	11477111250	ARM SUPPORT CAM .....	1	INCLUDES ITEMS W/*
13*	11477111260	ROCKER ARM SUPPORT	1	
14*	11477111650	INTAKE ARM ASSY.	1	
16	11425011240	VALVE ADJUST. SCREW	1	
17	26856060002	LOCK NUT 6	1	
18*	11477111660	EXHAUST ARM ASSY.	1	
20	11425011240	VALVE ADJUST. SCREW	1	
21	26856060002	LOCK NUT 6	1	
22*	22242000120	CIR CLIP 12	2	
23	11425011340	VALVE STEM SEAR	2	
24	11926011370	VALVE CAP	2	
25	11477111461	NOZZLE GASKET	1	
26	11429511470	NOZZLE SPACER	1	
27	11429911600	VALVE SPRING WASHER	2	
28	11429911901	NOZZLE RETAINER	1	
29	26106060452	BOLT M 6X45 PLATED	2	
30	11471811910	STUD BOLT M6X65	2	
31	26366060002	NUT M 6	2	
32	11477111310	BONNET GASKET	1	
33	11477111970	BONNET COMPLETE .....	1	INCLUDES ITEMS W/#
35#	11425003591	SHAFT ASSY. DECOMP.	1	
38#	11428803641	SPRING	1	
39#	11428803950	PIN	1	
55	26106060552	BOLT M 6X 55 PLATED	3	

# YANMAR L-48V6 ENGINE — CRANKSHAFT AND CAMSHAFT ASSY.

CRANKSHAFT AND CAMSHAFT ASSY.

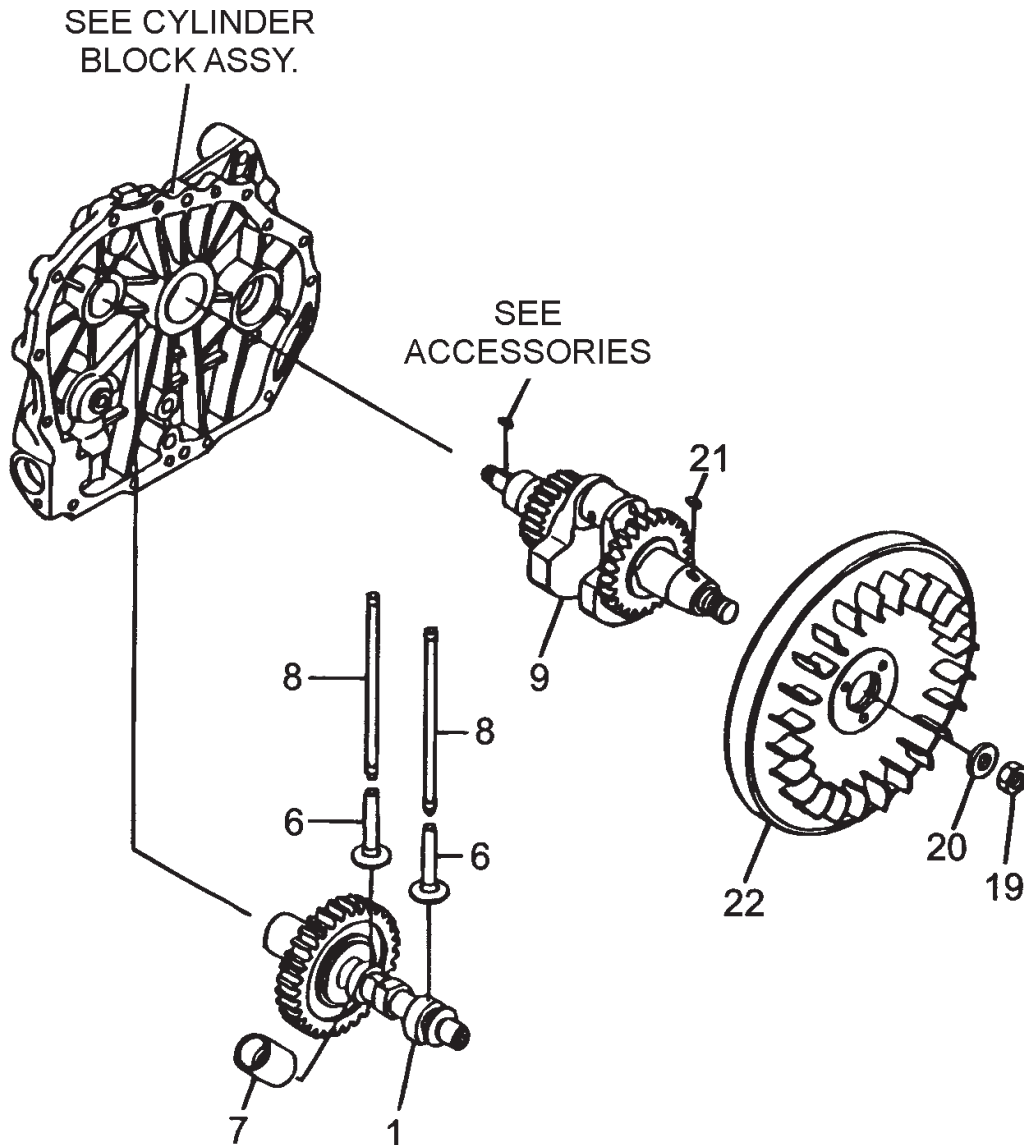

## YANMAR L-48V6 ENGINE — CRANKSHAFT AND CAMSHAFT ASSY.

### CRANKSHAFT AND CAMSHAFT ASSY.

<u>NO.</u>	<u>PART NO.</u>	<u>PART NAME</u>	<u>QTY.</u>	<u>REMARKS</u>
1	71429514580	CAMSHAFT (D) ASSY.	1	
6	11429914200	TAPPET	2	
7	11477114260	TAPPET, F.O.	1	
8	11425014451	PUSH ROD	2	
9	71478121740	CRANKSHAFT (EDRM) ASSY.	1	
19	11429921220	NUT	1	
20	11429921550	FLYWHEEL WASHER	1	
21	22512040120	KEY 4X 12	1	
22	11429921470	FLYWHEEL	1	

# YANMAR L-48V6 ENGINE — PISTON ASSY.

PISTON ASSY.

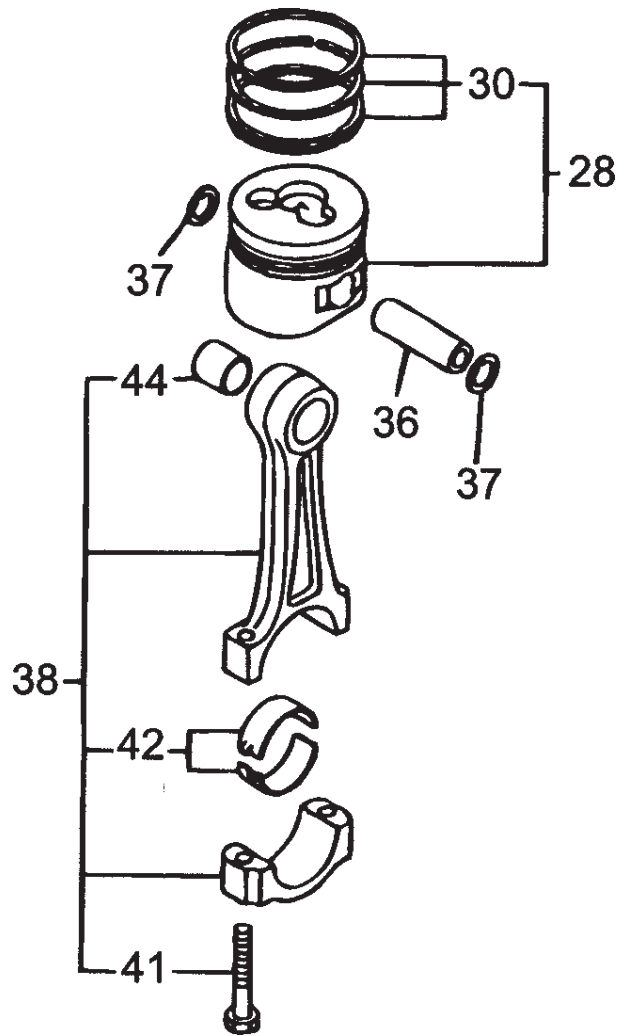

# YANMAR L-48V6 ENGINE — PISTON ASSY.

PISTON ASSY.

<u>NO.</u>	<u>PART NO.</u>	<u>PART NAME</u>	<u>QTY.</u>	<u>REMARKS</u>
1	71429514580	CAMSHAFT (D) ASSY.	1	
6	11429914200	TAPPET	2	
7	11477114260	TAPPET, F.O.	1	
8	11425014451	PUSH ROD	2	
9	71478121740	CRANKSHAFT (EDRM) ASSY.	1	
19	11429921220	NUT	1	
20	11429921550	FLYWHEEL WASHER	1	
21	22512040120	KEY 4X 12	1	
22	11429921470	FLYWHEEL	1	
28	71429522720	PISTON W/RINGS (D) STD. ....	1	INCLUDES ITEMS W/#
28	71429522620	PISTON W/RING OS=0.25 ....	1	INCLUDES ITEMS W/#
28	71429522580	PISTON W/RING OS=0.50 ....	1	INCLUDES ITEMS W/#
30#	71429522500	PISTON RING SET STD.	1	
30#	71429522540	PISTON RING SET OS=0.25	1	
30#	71429522550	PISTON RING SET OS=0.50	1	
36	11429922300	PISTON PIN	1	
37	22252000190	CIRCLIP 19	2	
38	71429923700	CONNECTING ROD ASSY. ....	1	INCLUDES ITEMS W/*
41*	11926523200	ROD BOLT	2	
42*	71477023600	CRANKPIN BEARING U.S=STD.	1	
42*	71477023610	CRANKPIN BEARING U.S=0.25	1	
42*	71477023620	CRANKPIN BEARING U.S=0.50	1	
44*	11477023100	PISTON PIN BUSH	1	

# YANMAR L-48V6 ENGINE — LUB. OIL PUMP AND GOVERNOR ASSY.

LUB. OIL PUMP AND GOVERNOR ASSY.

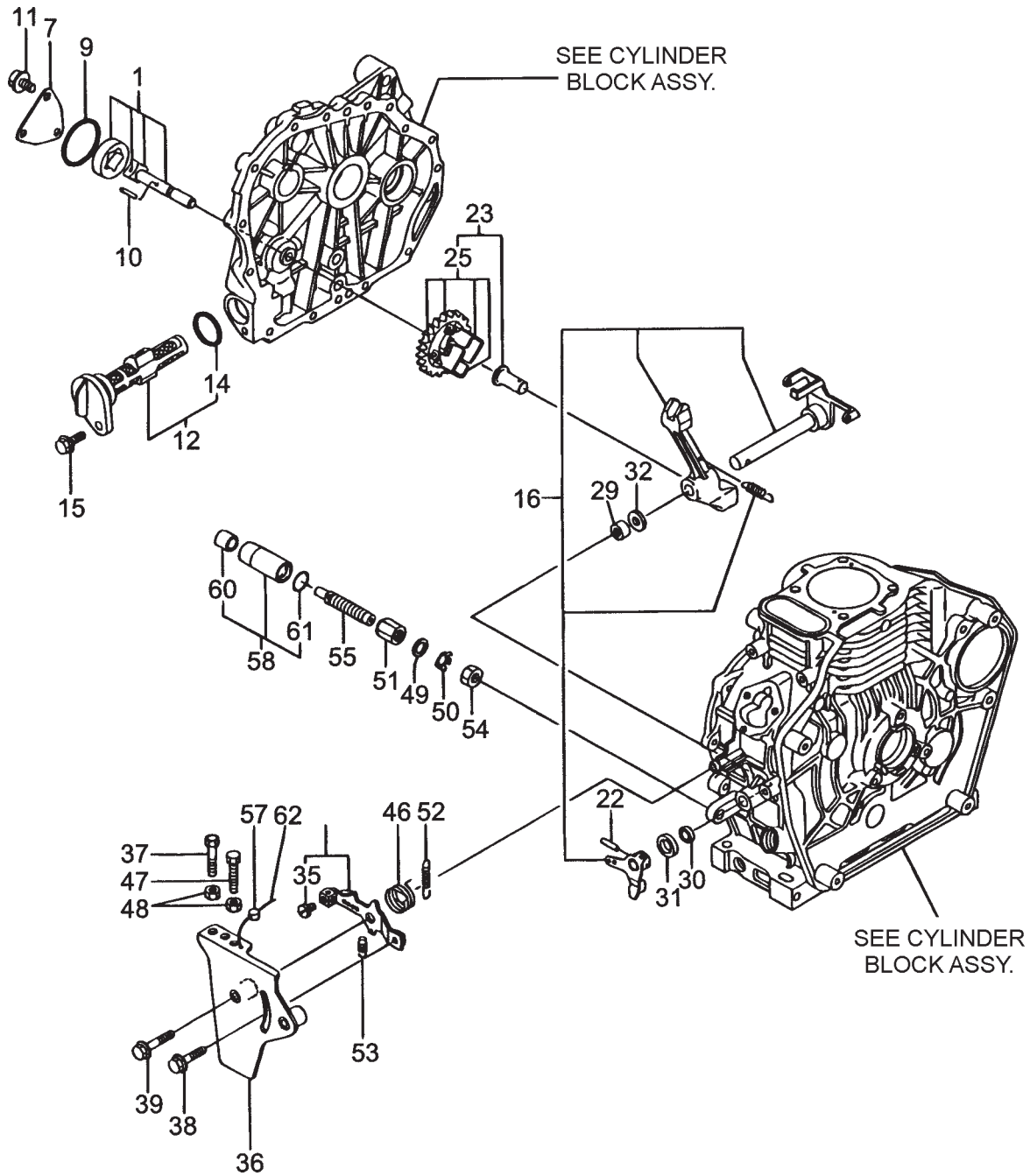

# YANMAR L-48V6 ENGINE — LUB. OIL PUMP AND GOVERNOR ASSY.

## LUB. OIL PUMP & GOVERNOR ASSY.

<u>NO.</u>	<u>PART NO.</u>	<u>PART NAME</u>	<u>QTY.</u>	<u>REMARKS</u>
1	11425032010	LUB. OIL PUMP ASSY.	1	
7	11428432070	LUB. OIL PUMP COVER	1	
9	11429932570	O- RING COVER	1	
10	22312030160	PARALLEL PIN 3X16	1	
11	26106060122	BOLT M 6X 12 PLATED	3	
12	11429935110	LUB. OIL FILTER COMPLETE .....	1	INCLUDES ITEMS W/#
14#	24341000224	O- RING 1A S- 22.4	1	
15	26106060162	BOLT M 6X 16 PLATED	1	
16	11429561190	GOVERNOR LEVER ASSY.	1	
22	22322030200	TAPER PIN 3X20	1	
23	71477061100	GOVERNOR ASSY. ....	1	INCLUDES ITEMS W/*
25	11477061220	GOVERNOR WEIGHT ASSY.	1	
29	11477061520	NEEDLE BEARING	2	
30	11429961600	OIL SEAL	1	
31	11477061610	THRUST WASHER	1	
32	11429961190	GOVERNOR WASHER	1	
33	11477166050	REGULATOR HANDLE .....	1	INCLUDES ITEMS W/%
35%	26117040088	BOLT 4X 8	1	
36	11477266100	REGULATOR HANDLE BASE	1	
37	11429967080	ADJUSTING BOLT	1	
38	26106060302	BOLT M 6X 30 PLATED	1	
39	26106060352	BOLT M6X30 PLATED	1	
46	11429966440	RETURN SPRING	1	
47	11429966440	ADJUSTING BOLT	1	
48	26757060002	LOCK NUT M 6 PLATED	2	
49	11477161810	PLAIN WASHER 14	1	
50	11477161830	PLATE	1	
51	11429561940	NUT	1	
52	11429966010	REGULATOR SPRING	1	
53	11429966200	RETURN SPRING	1	
54	11477166690	NUT M14	1	
55	11477166600	FUEL LIMITER ASSY.	1	
57	13521061090	LEAD	1	
58	11477161890	PROTECTOR CMP .....	1	INCLUDES ITEMS W/+
60+	11477161960	SPACER	1	
61+	24311000180	O- RING 1A P-18.0	1	
62	22451060000	WIRE 0.6	1	



# YANMAR L-48V6 ENGINE — COOLING AND STARTING ASSY.

## COOLING & STARTING DEVICE ASSY.

<u>NO.</u>	<u>PART NO.</u>	<u>PART NAME</u>	<u>QTY.</u>	<u>REMARKS</u>
1	11429945210	CYLINDER COVER	1	
2	26106060122	BOLT M 6X12 PLATED	1	
3	11477145110	COOLING FAN CASE	1	
5	11429945300	CUSHION RUBBER	4	
6	11429945310	FAN CASE COLLAR	4	
7	11429945330	FAN CASE SEAL	1	
8	11429945350	FAN CASE BOLT	4	
10	11429976250	RECOIL STARTER (D) ASSY. ....	1	INCLUDES ITEMS W/*
11*	11429976500	STARTER CASE	1	
13*	11429976520	REEL	1	
15*	11439976550	RATCHET	1	
17*	11439976540	SPIRAL SPRING	1	
19*	11439975550	RATCHET COVER	1	
20*	11439976560	SPRING	1	
21*	11439976570	RETURN SPRING	1	
22*	11439976580	SCREW	1	
23*	11439976620	STARTER KNOB	1	
24*	11429976630	STARTER ROPE	1	
25	11429976590	STARTER PULLEY	1	
26	26106060082	BOLT M 6X 8 PLATED	4	
27	26106060122	BOLT M6X 12 PLATED	3	
28	12910061850	BORE PLUG 12	1	

# YANMAR L-48V6 ENGINE — FUEL INJECTION PUMP ASSY.

## FUEL INJECTION PUMP ASSY.

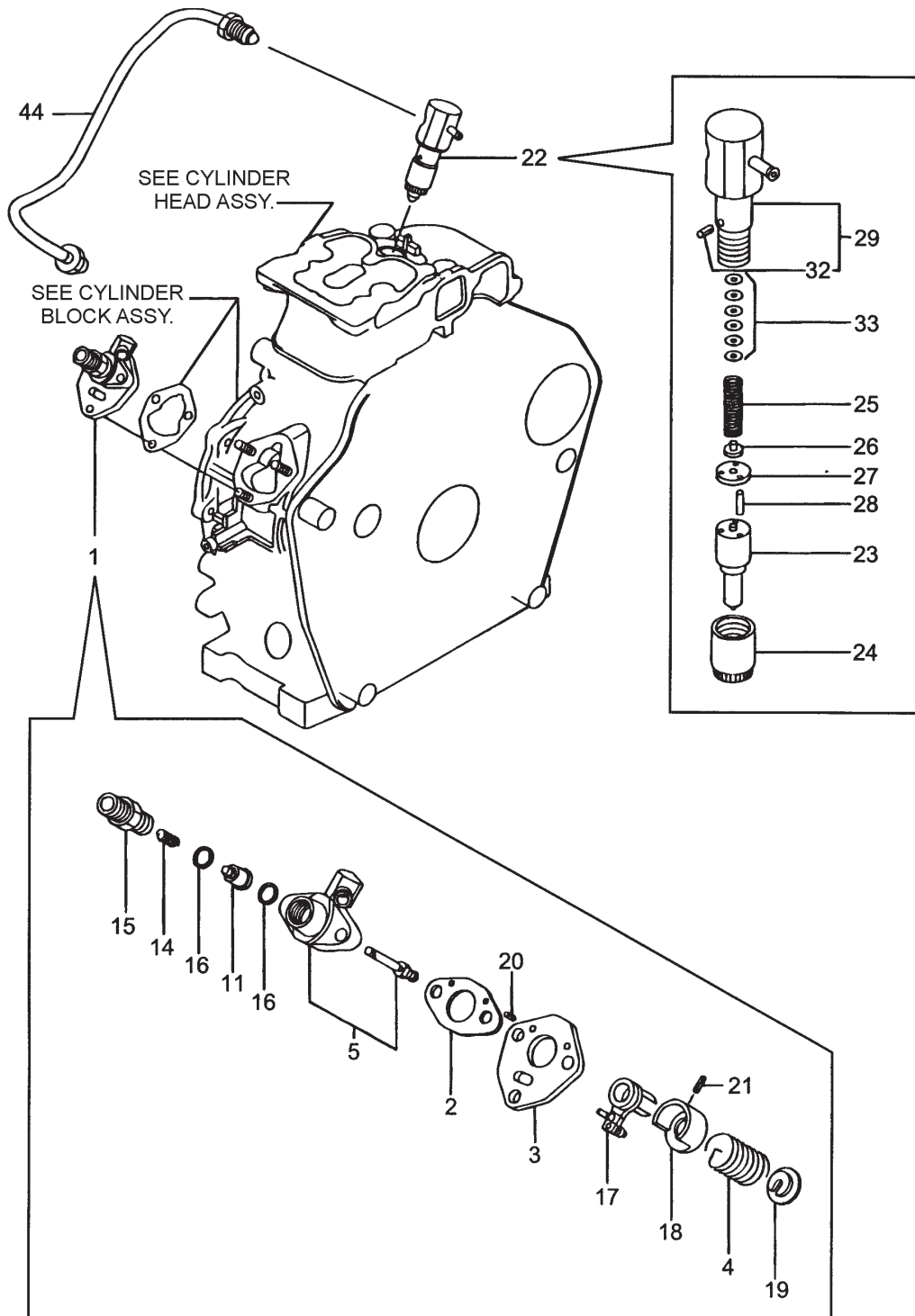

# YANMAR L-48V6 ENGINE — FUEL INJECTION PUMP ASSY.

## FUEL INJECTION PUMP ASSY.

<u>NO.</u>	<u>PART NO.</u>	<u>PART NAME</u>	<u>QTY.</u>	<u>REMARKS</u>
1	71477551100	INJECTION PUMP ASSY., F .....	1 .....	INCLUDES ITEMS W/*
2*	10554651020	GASKET	1	
3*	11425051080	PLATE	1	
4*	11425051160	SPRING	1	
5*	11435051200	FUEL INJECTION PUMP BODY	1	
11*	11425051300	VALVE ASSY. DELIVERY	1	
14*	10554651330	DELIVERY VALVE SPRING	1	
15*	11425051340	F.I.P. DELIVERY HOLDER	1	
16*	12455051350	DELIVERY GASKET	2	
17*	11425051600	CONTROL LEVER ASSY.	1	
18*	11425051640	SPRING SEAT ( A)	1	
19*	11425051650	SPRING SEAT (B)	1	
20*	22351020006	SPRING PIN 2X 6	2	
21*	22351030008	SPRING PIN 3X 8	1	
22	71477553101	FUEL INJECTION VALVE ASSY. ....	1 .....	INCLUDES ITEMS W/ #
23 #	11477153001	FUEL INJECTION NOZZLE ASSY.	1	
24 #	11959353080	NOZZLE CASE NUT	1	
25 #	11425053120	NOZZLE SPRING	1	
26 #	11959353130	SPRING RETAINER	1	
27 #	11477553140	VALVE STOP SPACER	1	
28 #	11477553210	PIN	2	
29 #	11477553100	HOLDER ASSY. ....	1 .....	INCLUDES ITEMS W/ %
32 #%	11477553330	PIN	1	
33 #	11425053400	SHIM PACK	1	
44	11477159803	FUEL INJECTION PIPE	1	

# YANMAR L-48V6 ENGINE — AIR CLEANER ASSY.

AIR CLEANER ASSY.

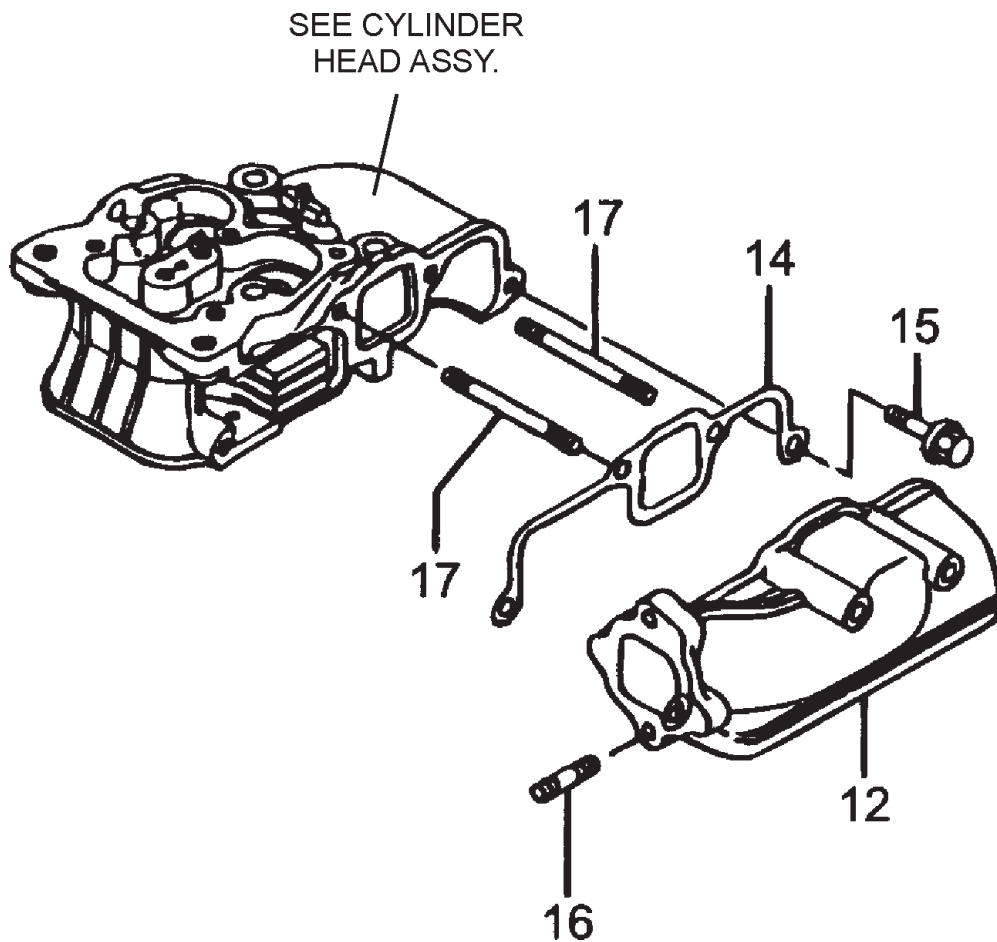

# YANMAR L-48V6 ENGINE — AIR CLEANER ASSY.

AIR CLEANER ASSY.

<u>NO.</u>	<u>PART NO.</u>	<u>PART NAME</u>	<u>QTY.</u>	<u>REMARKS</u>
12	1147212010	AIR INTAKE PIPE	1	
14	11477112200	AIR INTAKE GASKET	1	
15	26106060252	BOLT M 6X 25 PLATED	2	
16	26226060142	STUD M 6X14 PLATED	1	
17	26226060552	STUD M 6X 55	2	

# YANMAR L-48V6 ENGINE — MUFFLER ASSY.

MUFFLER ASSY.

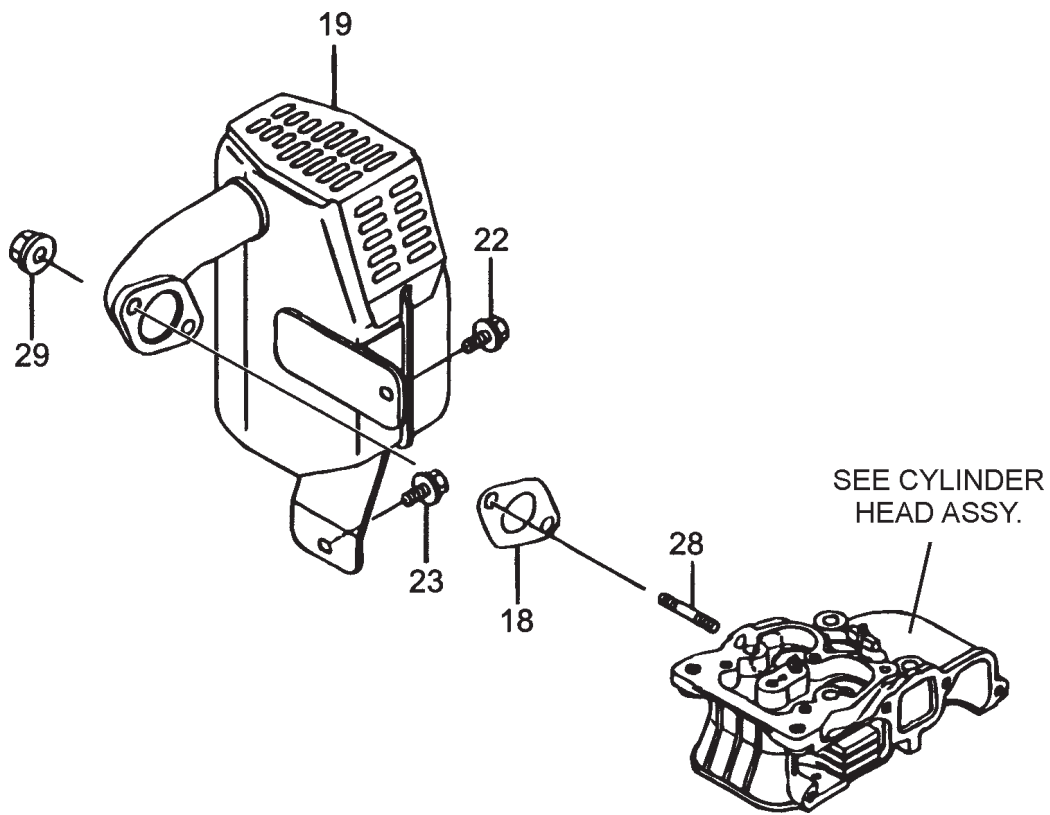

## YANMAR L-48V6 ENGINE — MUFFLER ASSY.

MUFFLER ASSY.

<u>NO.</u>	<u>PART NO.</u>	<u>PART NAME</u>	<u>QTY.</u>	<u>REMARKS</u>
18	11429913200	MUFFLER GASKET	1	
19	11428413500	MUFFLER ASSY., DRM	1	
22	26106060142	BOLT M 6X14 PLATED	1	
23	26106060182	BOLT M 6X18 PLATED	1	
28	26216080182	STUD M 8X 18 PLATED	2	
29	26366080002	NUT M 8	2	



# YANMAR L-48V6 ENGINE — TOOLS, LABELS AND GASKET SET ASSY.

## TOOLS, LABELS AND GASKET SET ASSY.

<u>NO.</u>	<u>PART NO.</u>	<u>PART NAME</u>	<u>QTY.</u>	<u>REMARKS</u>
4	11429907110	YANMAR LABEL	1	
7	11429907160	DIESEL LABEL	1	
10	11429992590	TOOL ASSY.....	1	INCLUDES ITEMS W/*
11*	11429992600	TOOL BAG	1	
12*	11429992710	SPANNA	1	
13*	11429992720	SPANNA	1	
14*	11429992730	DRIVER	1	
15*	11429992740	FUEL FITTING	1	
16	71411092600	GASKET SET .....	1	INCLUDES ITEMS W/#
17#	11429501330	CYLINDER HEAD GASKET ASSY.	1	
23#	11429901280	O- RING	1	
24#	11429901410	CRANK CASE GASKET	1	
25#	11429901950	O- RING	2	
26#	11425001841	GASKET	1	
27#	22190160002	WASHER SEAL 16S	2	
28#	11425011340	VALVE STEM SEAL	2	
29#	11477111461	NOZZLE GASKET	1	
30#	11477111310	BONNET GASKET	1	
31#	11429912210	AIR CLEANER GASKET	1	
32#	11477112200	AIR INTAKE GASKET	1	
33#	11429913200	MUFFLER GASKET	1	
34#	11429932570	O- RING, COVER	1	
35#	24341000100	O- RING 1A S-10.0	1	
36#	23414080000	PACKING 8	1	
37#	24341000224	O- RING 1A S- 22.4	1	
38#	24341000150	O- RING 1A S- 15.0	1	

# YANMAR L-48V6 ENGINE — ACCESSORIES ASSY.

ACCESSORIES ASSY.

SEE AIR CLEANER ASSY.

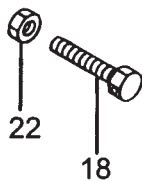
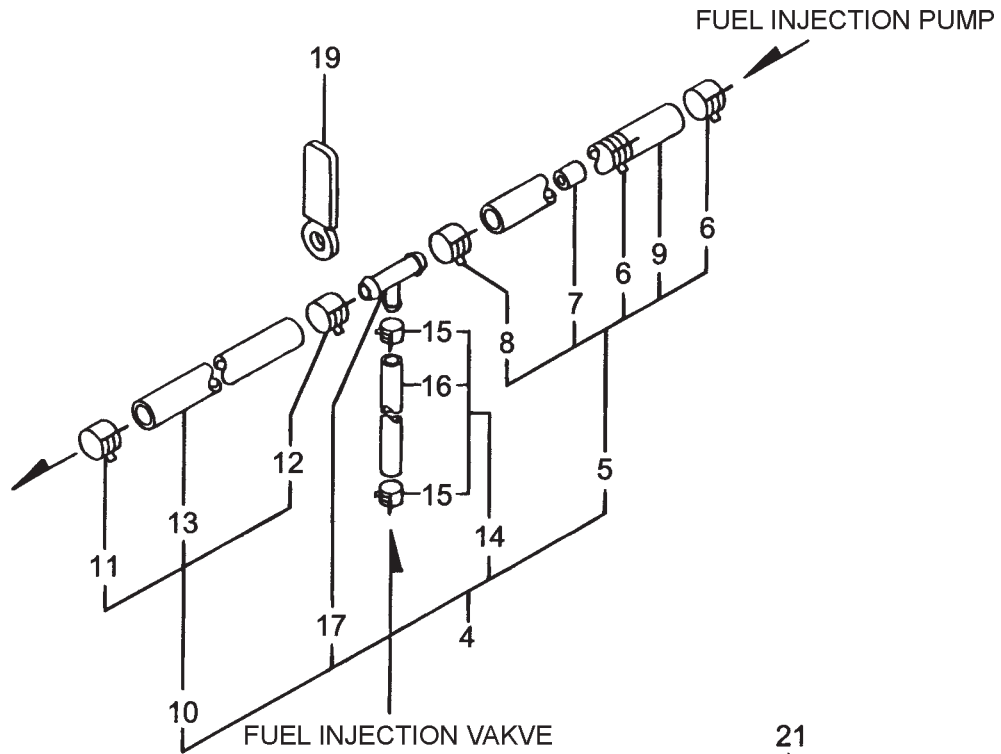
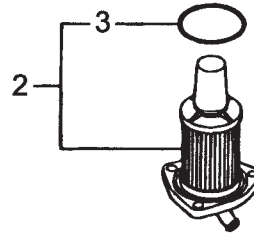
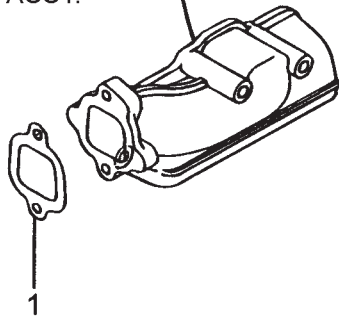

SEE CRANKSHAFT AND CAMSHAFT ASSY.

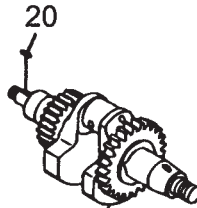

SEE CYLINDER BLOCK ASSY.

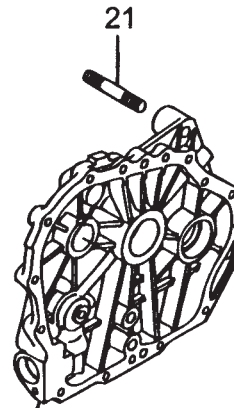

# YANMAR L-48V6 ENGINE — ACCESSORIES ASSY.

## ACCESSORIES ASSY.

<u>NO.</u>	<u>PART NO.</u>	<u>PART NAME</u>	<u>QTY.</u>	<u>REMARKS</u>
1	11428412200	AIR INTAKE GASKET	1	
2	18325455120	FUEL STRAINER ASSY. ....	1	INCLUDES ITEMS W/*
3*	24341000450	O- RING 1A S- 45.0	1	
4	11428459101	PIPE ASSY. FUEL OIL .....	1	INCLUDES ITEMS W/ #
5 #	11428459020	FUEL B. PIPE ASSY. ....	1	INCLUDES ITEMS W/ +
6+	10699044660	HOSE 12.5 BAND	2	
7+	18325059040	PIECE	1	
8+	12476659050	CLAMP 11.5	1	
9+	18325059051	FUEL OIL PIPE	1	
10 #	11428459030	FUEL A PIPE ASSY. ....	1	INCLUDES ITEMS W/ >
11 >	10699044660	HOSE 12.5 BAND	1	
12 >	12476659050	CLAMP 11.5	1	
13 >	18326659050	RUBBER HOSE 8X13X255	1	
14 #	11428459040	FUEL C PIPE ASSY. ....	1	INCLUDES ITEMS W/ %
15%	12472259050	CLAMP 9	2	
16%	11465459070	FUEL RETURN PIPE	1	
17 #	11428459710	JOINT	1	
18	11425066440	ADJUSTING BOLT	1	
19	16071078710	CORD CLAMP	2	
20	22512040120	KEY 4X 12	1	
21	26226100452	STUD BOLT	2	
22	26757060002	LOCK NUT M 6 PLATED	1	

**PAYMENT TERMS**

Terms of payment for parts are net 30 days.

**FREIGHT POLICY**

All parts orders will be shipped collect or prepaid with the charges added to the invoice. All shipments are F.O.B. point of origin. Multiquip's responsibility ceases when a signed manifest has been obtained from the carrier, and any claim for shortage or damage must be settled between the consignee and the carrier.

**MINIMUM ORDER**

The minimum charge for orders from Multiquip is \$15.00 net. Customers will be asked for instructions regarding handling of orders not meeting this requirement.

**RETURNED GOODS POLICY**

Return shipments will be accepted and credit will be allowed, subject to the following provisions:

1. A Returned Material Authorization must be approved by Multiquip prior to shipment.
2. To obtain a Return Material Authorization, a list must be provided to Multiquip Parts Sales that defines item numbers, quantities, and descriptions of the items to be returned.
  - a. The parts numbers and descriptions must match the current parts price list.
  - b. The list must be typed or computer generated.
  - c. The list must state the reason(s) for the return.
  - d. The list must reference the sales order(s) or invoice(s) under which the items were originally purchased.
  - e. The list must include the name and phone number of the person requesting the RMA.
3. A copy of the Return Material Authorization must accompany the return shipment.
4. Freight is at the sender's expense. All parts must be returned freight prepaid to Multiquip's designated receiving point.

5. Parts must be in new and resalable condition, in the original Multiquip package (if any), and with Multiquip part numbers clearly marked.

6. The following items are not returnable:

- a. Obsolete parts. (If an item is in the price book and shows as being replaced by another item, it is obsolete.)
- b. Any parts with a limited shelf life (such as gaskets, seals, "O" rings, and other rubber parts) that were purchased more than six months prior to the return date.
- c. Any line item with an extended dealer net price of less than \$5.00.
- d. Special order items.
- e. Electrical components.
- f. Paint, chemicals, and lubricants.
- g. Decals and paper products.
- h. Items purchased in kits.

7. The sender will be notified of any material received that is not acceptable.

8. Such material will be held for five working days from notification, pending instructions. If a reply is not received within five days, the material will be returned to the sender at his expense.

9. Credit on returned parts will be issued at dealer net price at time of the original purchase, less a 15% restocking charge.

10. In cases where an item is accepted, for which the original purchase document can not be determined, the price will be based on the list price that was effective twelve months prior to the RMA date.

11. Credit issued will be applied to future purchases only.

**PRICING AND REBATES**

Prices are subject to change without prior notice. Price changes are effective on a specific date and all orders received on or after that date will be billed at the revised price. Rebates for price declines and added charges for price increases will not be made for stock on hand at the time of any price change.

Multiquip reserves the right to quote and sell direct to Government agencies, and to Original Equipment Manufacturer accounts who use our products as integral parts of their own products.

**SPECIAL EXPEDITING SERVICE**

A \$35.00 surcharge will be added to the invoice for special handling including bus shipments, insured parcel post or in cases where Multiquip must personally deliver the parts to the carrier.

**LIMITATIONS OF SELLER'S LIABILITY**

Multiquip shall not be liable hereunder for damages in excess of the purchase price of the item with respect to which damages are claimed, and in no event shall Multiquip be liable for loss of profit or good will or for any other special, consequential or incidental damages.

**LIMITATION OF WARRANTIES**

No warranties, express or implied, are made in connection with the sale of parts or trade accessories nor as to any engine not manufactured by Multiquip. Such warranties made in connection with the sale of new, complete units are made exclusively by a statement of warranty packaged with such units, and Multiquip neither assumes nor authorizes any person to assume for it any other obligation or liability whatever in connection with the sale of its products. Apart from such written statement of warranty, there are no warranties, express, implied or statutory, which extend beyond the description of the products on the face hereof.



# OPERATION & PARTS MANUAL

## HERE'S HOW TO GET HELP

PLEASE HAVE THE MODEL AND SERIAL  
NUMBER *ON-HAND* WHEN CALLING

### UNITED STATES

#### ***Multiquip Corporate Office***

18910 Wilmington Ave. Tel. (800) 421-1244  
Carson, CA 90746 Fax (800) 537-3927  
Contact: mq@multiquip.com

#### ***Mayco Parts***

800-306-2926 Fax: 800-672-7877  
310-537-3700 Fax: 310-637-3284

#### ***Service Department***

800-421-1244 Fax: 310-537-4259  
310-537-3700

#### ***MQ Parts Department***

800-427-1244 Fax: 800-672-7877  
310-537-3700 Fax: 310-637-3284

#### ***Warranty Department***

800-421-1244, Ext. 279 Fax: 310-537-1173  
310-537-3700, Ext. 279

#### ***Technical Assistance***

800-478-1244 Fax: 310-631-5032

### MEXICO

#### ***MQ Cipsa***

Carr. Fed. Mexico-Puebla KM 126.5 Tel: (52) 222-225-9900  
Momoxpan, Cholula, Puebla 72760 Mexico Fax: (52) 222-285-0420  
Contact: pmastretta@cipsa.com.mx

### CANADA

#### ***Multiquip***

4110 Industriel Boul. Tel: (450) 625-2244  
Laval, Quebec, Canada H7L 6V3 Fax: (450) 625-8664  
Contact: jmartin@multiquip.com

### UNITED KINGDOM

#### ***Multiquip (UK) Limited Head Office***

Hanover Mill, Fitzroy Street, Tel: 0161 339 2223  
Ashton-under-Lyne, Fax: 0161 339 3226  
Lancashire OL7 0TL  
Contact: sales@multiquip.co.uk

### BRAZIL

#### ***Multiquip***

Av. Evandro Lins e Silva, 840 - grupo 505 Tel: 011-55-21-3433-9055  
Barra de Tijuca - Rio de Janeiro Fax: 011-55-21-3433-9055  
Contact: cnavarro@multiquip.com.br, srentes@multiquip.com.br

© COPYRIGHT 2007, MULTIQUIP INC.

Multiquip Inc, the MQ logo and the Mikasa logo are registered trademarks of Multiquip Inc. and may not be used, reproduced, or altered without written permission. All other trademarks are the property of their respective owners and used with permission.

This manual **MUST** accompany the equipment at all times. This manual is considered a permanent part of the equipment and should remain with the unit if resold.

The information and specifications included in this publication were in effect at the time of approval for printing. Illustrations are based on the *MT-76D2 Tamping Rammer*. Illustrations, descriptions, references and technical data contained in this manual are for guidance only and may not be considered as binding. Multiquip Inc. reserves the right to discontinue or change specifications, design or the information published in this publication at any time without notice and without incurring any obligations.

Your Local Dealer is:

