

# OPERATION AND PARTS MANUAL



*Mikasa* SERIES  
**MODEL MVH-306DS2**  
**REVERSIBLE PLATE COMPACTOR**  
**(YANMAR L70V6GJ1R1AAS5 DIESEL ENGINE)**

Revision #2 (08/15/07)

To find the latest revision of this  
publication, visit our website at:  
[www.multiquip.com](http://www.multiquip.com)



**THIS MANUAL MUST ACCOMPANY THE EQUIPMENT AT ALL TIMES.**



**CALIFORNIA — Proposition 65 Warning**

Engine exhaust and some of its constituents are known to the State of California to cause cancer, birth defects and other reproductive harm.



## MIKASA MVH-306DS2 REVERSIBLE PLATE COMPACTOR

Proposition 65 Warning .....	2
Table Of Contents .....	4
Parts Ordering Procedures .....	5
Safety Message Alert Symbols .....	6-7
Rules for Safe Operation .....	8-9
Operation and Safety Decals .....	10
Specifications .....	11
Dimensions .....	12
Features .....	13
Plate Compactor Components .....	14
Engine Components .....	15
Pre-Inspection .....	16-17
Operation .....	18-21
Maintenance .....	22-25
Troubleshooting (Engine) .....	26
Troubleshooting (Compactor) .....	27

## PARTS ILLUSTRATIONS

Explanation Of Code In Remarks Column .....	28
Suggested Spare Parts .....	29
Nameplate and Decals .....	30-31
Vibrating Plate Assembly .....	32-33
Base and Engine Assembly .....	34-37
Vibrator Assembly .....	38-39
Control Handle Assembly .....	40-43
Hand Pump Assembly .....	44-45
Battery Assembly .....	46-47
Electric Device .....	48-49

## YANMAR L70V6GJ1R1AAS5 ENGINE

Cylinder Block Assembly .....	50-51
Cylinder Head Assembly .....	52-53
Air Cleaner Assembly .....	54-55
Muffler Assembly .....	56-57
Crankshaft and Camshaft Assembly .....	58-59
Piston Assembly .....	60-61
Lub. Oil Pump and Governor Assembly .....	62-63
Cooling and Starting Device Assembly .....	64-65
Fuel Injection Pump Assembly .....	66-67
Fuel Tank and Fuel Line Assembly .....	68-69
Starting Motor and Dynamo Assembly .....	70-71
Tools, Labels and Gasket Set Assembly .....	72-73
Terms and Conditions Of Sale — Parts .....	74

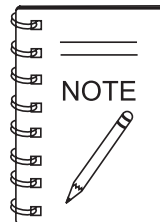

***Specification and part number are subject to change without notice.***

# PARTS ORDERING PROCEDURES

## Ordering parts has never been easier! Choose from three easy options:

Effective:  
January 1<sup>st</sup>, 2006

www.multiquip.com



### Order via Internet (Dealers Only):

Order parts on-line using Multiquip's SmartEquip website!

- View Parts Diagrams
- Order Parts
- Print Specification Information



If you have an MQ Account, to obtain a Username and Password, E-mail us at: [parts@multiquip.com](mailto:parts@multiquip.com).

To obtain an MQ Account, contact your District Sales Manager for more information.

Goto [www.multiquip.com](http://www.multiquip.com) and click on **Order Parts** to log in and save!

Use the **internet** and qualify for a **5% Discount** on *Standard orders* for all orders which include complete part numbers.\*

Note: Discounts Are Subject To Change



### Order via Fax (Dealers Only):

All customers are welcome to order parts via Fax.

**Domestic (US) Customers dial:**  
1-800-6-PARTS-7 (800-672-7877)

**Fax** your order in and qualify for a **2% Discount** on *Standard orders* for all orders which include complete part numbers.\*

Note: Discounts Are Subject To Change



**Order via Phone: Domestic (US) Dealers Call:**  
1-800-427-1244

### Non-Dealer Customers:

Contact your local Multiquip Dealer for parts or call 800-427-1244 for help in locating a dealer near you.



**International Customers** should contact their local Multiquip Representatives for Parts Ordering information.

## When ordering parts, please supply:

- |   |  |
|---|--|
| <input type="checkbox"/> Dealer Account Number                                | <input type="checkbox"/> Specify Preferred Method of Shipment:                         |
| <input type="checkbox"/> Dealer Name and Address                              | <input checked="" type="checkbox"/> UPS/Fed Ex <input checked="" type="checkbox"/> DHL |
| <input type="checkbox"/> Shipping Address (if different than billing address) | <input type="checkbox"/> Priority One <input checked="" type="checkbox"/> Truck        |
| <input type="checkbox"/> Return Fax Number                                    | <input type="checkbox"/> Ground  |
| <input type="checkbox"/> Applicable Model Number                              | <input type="checkbox"/> Next Day  |
| <input type="checkbox"/> Quantity, Part Number and Description of Each Part   | <input type="checkbox"/> Second/Third Day  |

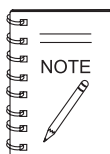

All orders are treated as *Standard Orders* and will ship the same day if received prior to 3PM PST.

WE ACCEPT ALL MAJOR CREDIT CARDS!



# MVH-306DS2 PLATE COMPACTOR — SAFETY MESSAGE ALERT SYMBOLS

## FOR YOUR SAFETY AND THE SAFETY OF OTHERS!

Safety precautions should be followed at all times when operating this equipment. Failure to read and understand the Safety Messages and Operating Instructions could result in injury to yourself and others.

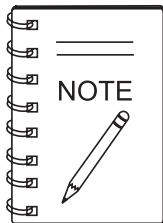

This Owner's Manual has been developed to provide complete instructions for the safe and efficient operation of the Multiquip Model MVH-306DS2 Reversible Plate Compactor.

Refer to the engine manufacturer's instructions for data relative to its safe operation.

**Before using this reversible plate compactor, ensure that the operating individual has read and understands all instructions in this manual.**

## SAFETY MESSAGE ALERT SYMBOLS

The three (3) Safety Messages shown below will inform you about potential hazards that could injure you or others. The Safety Messages specifically address the level of exposure to the operator, and are preceded by one of three words: **DANGER**, **WARNING**, or **CAUTION**.

### **DANGER**

You **WILL** be **KILLED** or **SERIOUSLY INJURED** if you **DO NOT** follow these directions.

### **WARNING**

You **CAN** be **KILLED** or **SERIOUSLY INJURED** if you **DO NOT** follow these directions.

### **CAUTION**

You **CAN** be **INJURED** if you **DO NOT** follow these directions.

Potential hazards associated with the operation of an **MVH-306DS2 Reversible Plate Compactor** will be referenced with Hazard Symbols which appear throughout this manual, and will be referenced in conjunction with Safety Message Alert Symbols.

## HAZARD SYMBOLS

### **WARNING - Lethal Exhaust Gases**

Engine exhaust gases contain poisonous carbon monoxide. This gas is colorless and odorless, and can cause death if inhaled. **NEVER** operate this equipment in a confined area or enclosed structure that does not provide ample free flow air.



### **WARNING - Explosive Fuel**

**Diesel** fuel is extremely flammable, and its vapors can cause an explosion if ignited. **DO NOT** start the engine near spilled fuel or combustible fluids.



**DO NOT** fill the fuel tank while the engine is running or hot. **DO NOT** overfill tank, since spilled fuel could ignite if it comes into contact with hot engine parts or sparks from the ignition system. Store fuel in approved containers, in well-ventilated areas and away from sparks and flames.

### **WARNING - Burn Hazards**

Engine components can generate extreme heat. To prevent burns, **DO NOT** touch these areas while the engine is running or immediately after operations. Never operate the engine with heat shields or heat guards removed.



### **CAUTION - Respiratory Hazard**

**ALWAYS** wear approved **respiratory** protection when required.



# MVH-306DS2 PLATE COMPACTOR — SAFETY MESSAGE ALERT SYMBOLS

## CAUTION - Rotating Parts

**NEVER** operate equipment with covers, or guards removed. Keep fingers, hands, hair and clothing away from all moving parts to prevent injury.



## CAUTION - Accidental Starting

**ALWAYS** place the **ON/OFF** switch in the **OFF** position, when the compactor is not in use.



## CAUTION - Sight and Hearing Hazards



**ALWAYS** wear approved eye and hearing protection.

## CAUTION - Equipment Damage Messages

Other important messages are provided throughout this manual to help prevent damage to your compactor, other property, or the surrounding environment.

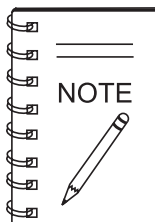

This reversible plate compactor, other property, or the surrounding environment could be damaged if you do not follow instructions.

# MVH-306DS2 PLATE COMPACTOR — RULES FOR SAFE OPERATION

## DANGER

Failure to follow instructions in this manual may lead to serious injury or even death! This equipment is to be operated by trained and qualified personnel only! This equipment is for industrial use only.

The following safety guidelines should always be used when operating the **compactor**.

### GENERAL SAFETY

- **DO NOT** operate or service this equipment before reading this entire manual.



- This equipment should not be operated by persons under 18 years of age.
- **NEVER** operate this equipment without proper protective clothing, shatterproof glasses, steel-toed boots and other protective devices required by the job.



- **NEVER** operate this equipment when not feeling well due to fatigue, illness or taking medicine.



- **NEVER** operate this equipment under the influence of drugs or alcohol.



- Whenever necessary, replace nameplate, operation and safety decals when they become difficult read.
- **ALWAYS** check the machine for loosened threads or bolts before starting.
- **ALWAYS** wear proper respiratory (mask) hearing and eye protection equipment when operating the compactor.



- **NEVER** touch the hot exhaust manifold, muffler or cylinder. Allow these parts to cool before servicing engine or plate compactor.



- **High Temperatures** – Allow the engine to cool before adding fuel or performing service and maintenance functions. Contact with *hot* components can cause serious burns.

- The engine of this compactor requires an adequate free flow of cooling air. **NEVER!** operate the compactor in any enclosed or narrow area where free flow of the air is restricted. If the air flow is restricted it will cause serious damage to the compactor or engine and may cause injury to people and property. Remember the engine gives off **DEADLY** gases.

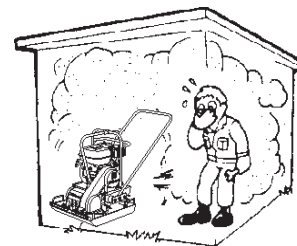

- **ALWAYS** refuel in a well-ventilated area, away from sparks and open flames.

- **ALWAYS** use extreme caution when working with **flammable** liquids. When refueling, **stop the engine** and allow it to cool. **DO NOT** smoke around or near the machine. Fire or explosion could result from fuel vapors, or if fuel is spilled on a hot engine.

- **NEVER** operate the equipment in an **explosive atmosphere** or near combustible materials. An explosion or fire could result causing severe **bodily harm or even death**.



- Topping-off to filler port is dangerous, as it tends to spill fuel.

- Refer to the **Engine Owner's Manual** for engine technical questions or information.

- **NEVER** use accessories or attachments, which are not recommended by Multiquip for this equipment. Damage to the equipment and/or injury to user may result.

- Manufacturer does not assume responsibility for any accident due to equipment modifications.

# MVH-306DS2 PLATE COMPACTOR — RULES FOR SAFE OPERATION

## Loading and Unloading (Crane):

- Before lifting, make sure that machine parts (hook and vibration insulator) are not damaged and screws are not loosened or lost.
- Always make sure crane or lifting device has been properly secured to the hook of guard frame on compactor.
- **NEVER** lift the machine while the engine is running.
- Use adequate lifting cable (wire or rope) of sufficient strength.
- Use one point suspension hook and lift straight upwards.
- **NEVER** allow any person or animal to stand underneath the machine while lifting.
- Try not to lift machine to unnecessary heights.

## TRANSPORTING

- **ALWAYS** shutdown engine before transporting.
- Tighten fuel tank cap securely and close fuel cock to prevent fuel from spilling.
- Drain fuel when transporting compactor over long distances or bad roads.
- **ALWAYS** tie down the compactor during transportation by securing the compactor's guard frame with rope.

## Maintenance Safety:

- **NEVER** lubricate components or attempt service on a running machine.
- **ALWAYS** allow the machine a proper amount of time to cool before servicing.
- Keep the machinery in proper running condition.
- Fix damage to the machine immediately and always replace broken parts.
- Dispose of hazardous waste properly. Examples of potentially hazardous waste are used motor oil, fuel and fuel filters.
- **DO NOT** use food or plastic containers to dispose of hazardous waste.
- **DO NOT** pour waste, oil or fuel directly onto the ground, down a drain or into any water source.

## Emergencies

- **ALWAYS** know the location of the nearest **fire extinguisher**.



- **ALWAYS** know the location of the nearest **first aid kit**.

- In emergencies **always** know the location of the nearest phone or **keep a phone on the job site**. Also know the phone numbers of the nearest **ambulance**, **doctor** and **fire department**. This information will be invaluable in case of an emergency.



Figure 18. Lifting the Compactor



# MVH-306DS2 — OPERATION AND SAFETY DECALS

Figure 2 displays the operation and safety decals as they appear on the reversible plate compactor. Should any of these decals become damaged or unreadable, contact the Multiquip Parts Department for a replacement set.



P/N 920203330

## MVH-306

P/N 920110370

Shell Tellus Oil  
46

NPA-748

P/N 920207480



P/N 920201580



P/N 920201950



P/N 920211010

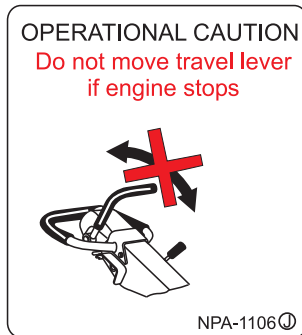

P/N 920204580

Fire Risk	Operate only in well-ventilated area	Do not stand next to machine while lifting	Do not use machine handle
Wear eye protection	Operate only in well-ventilated area	Do not touch moving parts in operation	Read operator's manual carefully before use

**OPERATIONAL CAUTION**

Prior to OPERATION, check the engine oil and fuel levels. If not enough, add to proper levels.

Warm up engine at low speed for 3-5 minutes.

Operate machine at full throttle speed. (incorrect clutch engagement causes clutch to burn.)

Use travel lever for forward & reverse motion. Do not push or pull travel lever strongly.

NPA-962

P/N: 920209620



P/N 920106760



P/N 920105070



CONTACT  
MQ PARTS DEPT.

Figure 2. Operation and Safety Decals

**Table 1. MVH-306DS2 Reversible Plate Compactor Specifications**

Centrifugal Force	10,125 lbs. (4,593 kg)
Vibration Frequency	4,400 vpm (70 Hz)
Traveling Speed	0 to 75 ft/min (0 to 23 m/min)
Plate Size (L x W)	18 x 34 in (45.72 x 86.36 cm)
External Plate Size (L x W)	24 x 34 in (60.96 x 86.36 cm)
Max. Area of Compaction (no extensions)	6,750 sq. ft. (2,057 sq. meters)
Overall Length	61.8 in (1570 mm)
Overall Width	18.0 in (457 mm)
Overall Height (with handle)	44.1 in (1120 mm)
Overall Height (without handle)	31.7 in (805 mm)
Operating Weight	692 lbs. (313 kg.)
Operating Weight (extension plates)	725 lbs. (328 kg.)
Lubricating Oil in Vibration Case	50.7 fl. oz. (1500 cc)

**TABLE 2. ENGINE SPECIFICATIONS**

Engine Make	YANMAR
Engine Model	L70V6GJ1R1AAS5
Engine Type	Air-cooled 4-cycle Diesel Engine
Cylinder Bore X Stroke	3.07 x 2.51 in (78 x 64 mm)
Displacement	10.34 fl oz (306 cm <sup>3</sup> )
Maximum Output	6.5 HP @3,600 RPM
Fuel Tank Capacity	3.5 quarts (3.31 liters)
Oil Capacity	1.16 quarts (1.10 liters)
Starting Method D/DS	Recoil/Electric
Dry Net Weight Recoil/Electric	72.75 lbs. (33 kg)/83.77 lbs. (38 kg)
Dimensions (L x W x H)	15.11 x 16.57 x 17.71 in (384 x 421 x 450 mm)

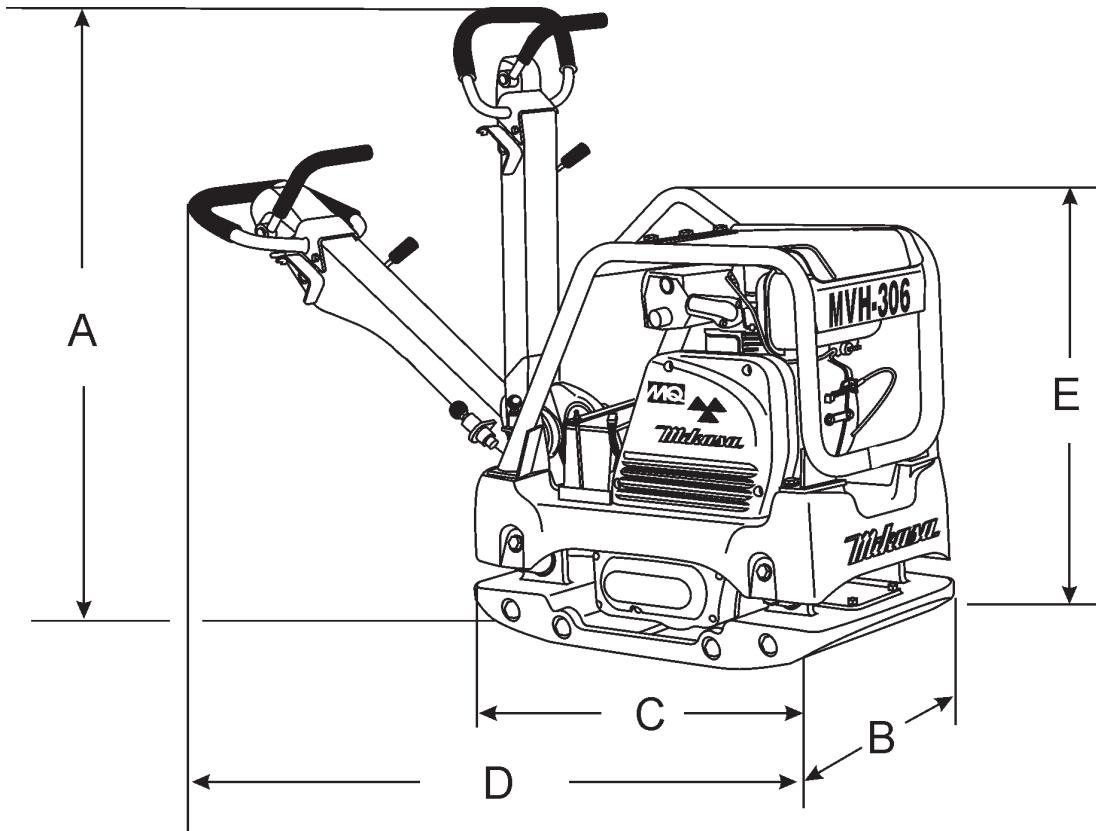

Figure 3. MVH-306DS2 Reversible Plate Compactor Dimensions

TABLE 3. DIMENSIONS	
REF.	DIMENSIONS
A	53 in. (134.6 cm.)
B	18 in. (46 cm.)
C	34 in. (86 cm.)
D	63.8 in. (162 cm.)
E	32.5 in. (82.5 cm.)

## Plate Compactor

The Mikasa MVH-306DS2 is a walk behind, reversible plate compactor designed for the compaction of sand, clay and asphalt. This plate compactor is a powerful compacting tool capable of applying a tremendous force in consecutive high frequency vibrations to a soil surface. Its applications include soil compacting for road, embankments and reservoirs as well as backfilling for gas pipelines, water pipelines and cable installation work.

## Vibratory Plates

The vibratory plates of the MVH-306DS2 produce low amplitude high frequency vibrations, designed to compact granular soils.

The resulting vibrations cause forward motion. The engine and handle are vibration isolated from the vibrating plate. The heavier the plate, the more compaction force it generates.

## Reversible Vibratory Plates

Reversible vibratory plates have two eccentric weights that allow a smooth transition for forward and reverse travel, plus increased compaction force as the result of dual weights.

Due to their weight and force, reversible plates are ideal for semi-cohesive soils.

## Frequency/Speed

The compactor's vibrating plate maximum frequency is 4400 vpm (vibrations per minute). The forward and reverse travel speed of the compactor is approximately 75 ft./minute (23 meters/minute).

## Engine

The Mikasa MVH-306DS2 Plate Compactor is equipped with a YANMAR L70V6GJ1R1AAS5 ENGINE diesel engine.

## Controls

Before starting the MVH-306DS2 Plate Compactor, identify and understand the function of the controls and components.

# MVH-306DS2— PLATE COMPACTOR COMPONENTS

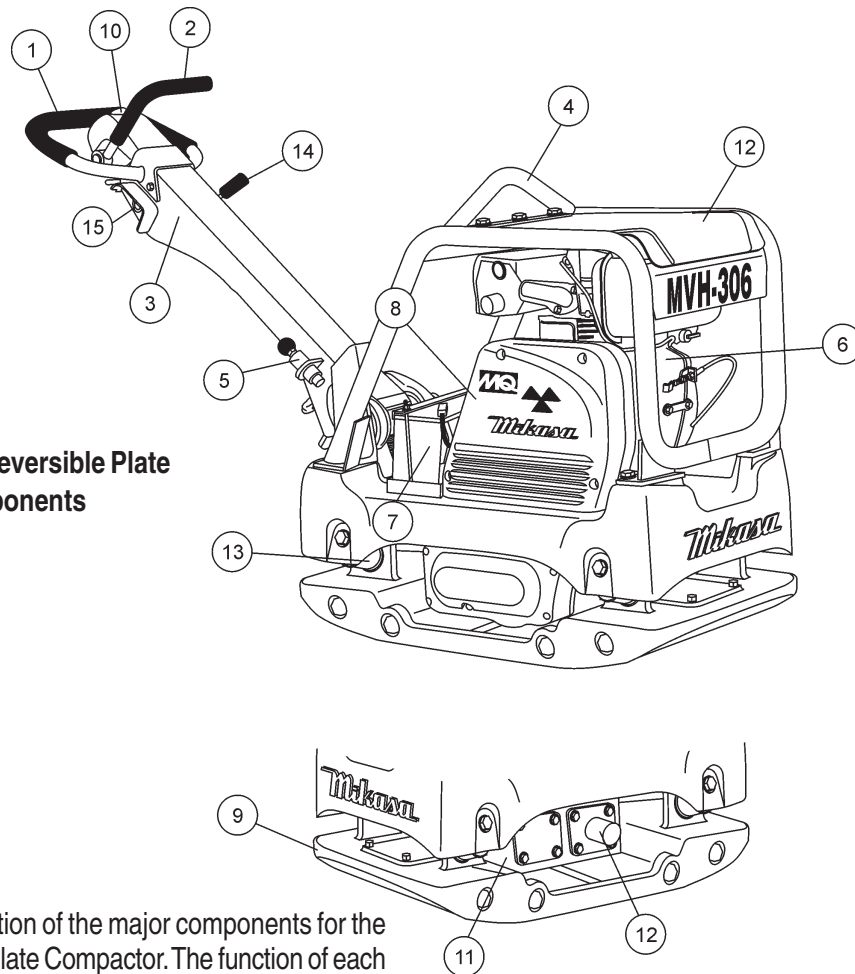

Figure 4. MVH-306DS2 Reversible Plate Compactor Components

Figure 4 illustrates the location of the major components for the MVH-306DS2 Reversible Plate Compactor. The function of each component is described below:

1. **Hand Grip** – When operating the compactor use this hand grip to maneuver the compactor.
2. **Forward & Reverse Lever** – *Push* the lever forward, the compactor will move in a forward direction, *pull* the lever backwards, the compactor will move in backwards direction. Placing the lever in the middle (midway) will cause the compactor not to move (neutral).
3. **Handle Bar** – When operating the compactor, this handle is to be in the downward position. When the compactor is to be *stored*, move the handle bar to the upright position.
4. **Guard Hook** - Used to lift the machine with crane or other lifting device.
5. **Stopper** - Locks the handle in place in the upward position for stowing.
6. **Engine** – This plate compactor uses a **YANMAR L-70V6** diesel engine. Refer to the owner's manual for engine information and related topics.
7. **Battery (Option)** - This unit uses a 12-volt battery. See maintenance of this manual for proper care of battery.
8. **Belt Cover** – Remove this cover to gain access to the V-belts. **NEVER** run the compactor without the V-belt cover. If the V-belt cover is not installed, the possibility exist that your hand may get caught between the V-belt and clutch, thus causing serious injury and bodily harm.
9. **Base Plate** – Designed to compact sand, clay, and asphalt.
10. **Oil Reservoir** – Fill with Shell Tellus Oil 46 or equivalent grade hydraulic oil.
11. **Vibration Case** – Encloses the eccentric, gears and counter weights.
12. **Hydraulic Cylinder** – Activated by moving the travel lever. The cylinder controls the direction of movement by the plate compactor.
13. **Shock Absorber** – Protects plate compactor from damage by absorbing vibration during operation.
14. **Throttle Lever** – Controls speed of the plate compactor. Place straight vertically to start, *push* fully counterclockwise for full throttle and fully clockwise to stop plate compactor.
14. **Ignition Switch (Option)** – Provided for electric start models only

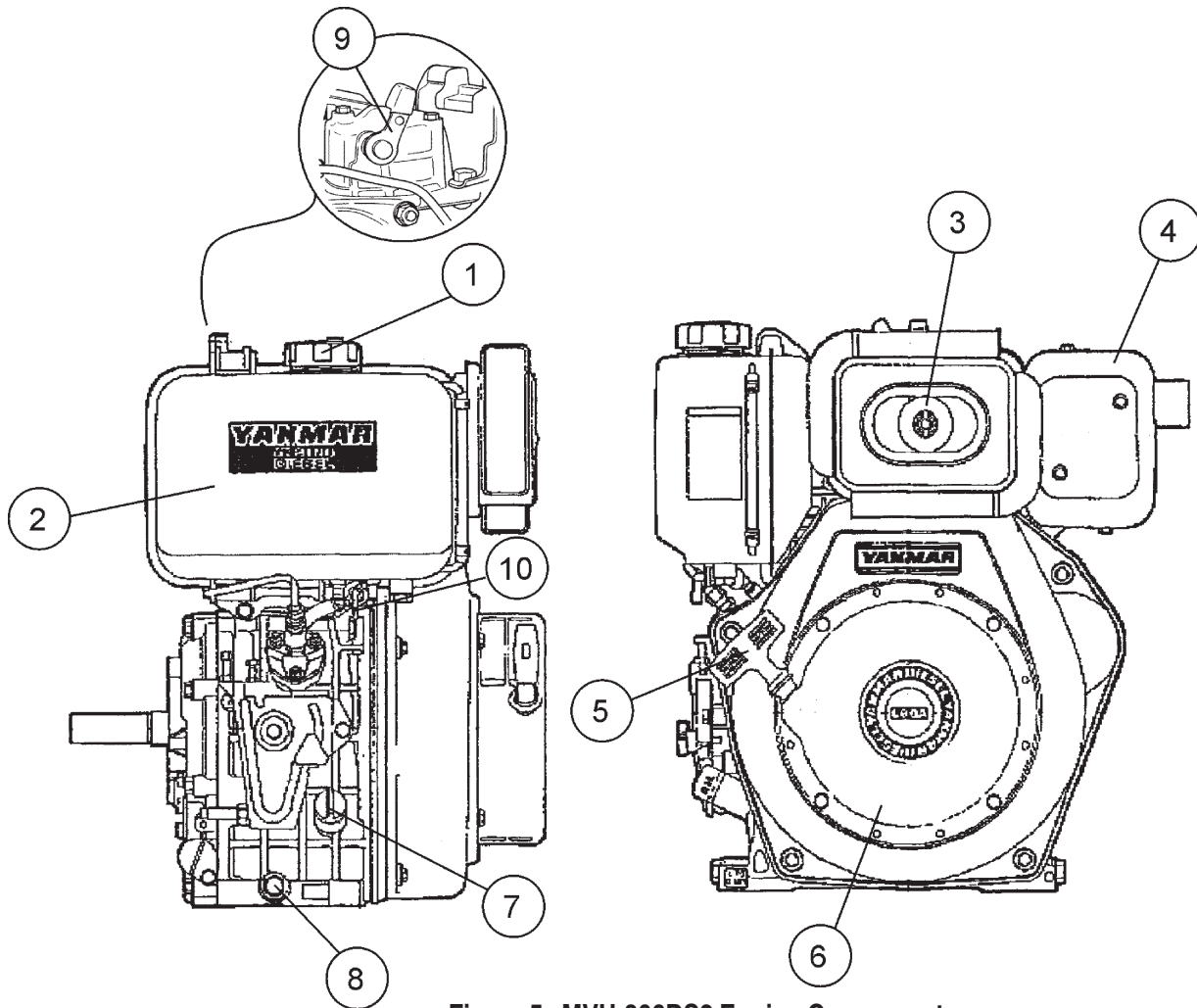

Figure 5. MVH-306DS2 Engine Components

## ENGINE COMPONENTS

Figure 5 illustrates the location of the major lever components of the engine. Each component is described below:

1. **Fuel Filler Cap** – Remove this cap to add unleaded gasoline to the fuel tank. Make sure cap is tighten securely. **DO NOT** over fill.
2. **Fuel Tank** – Capacity is 3.5 quarts (3.31 liters) of diesel fuel.
3. **Air Cleaner** – Prevents dirt and other debris from entering the fuel system. Remove wing-nut on top of air filter cannister to gain access to filter element.
4. **Muffler** – Used to reduce noise and emissions.
5. **Recoil Starting Handle (pull rope)** – Type of engine starting method. Alternate type would be electric start (ignition key).
6. **Recoil Starter**– Manual-starting method. Pull the starter grip until resistance is felt, then pull briskly and smoothly.
7. **Oil Filler Cap / Dipstick** – Remove this cap to add oil to the engine crankcase. Read dipstick to determine if oil level is low. **DO NOT** over fill.
8. **Oil Drain Plug** – Unscrew plug to drain oil from engine crankcase. Dispose of oil in a safe manner.
9. **Decompression Lever**– Press down before starting engine. To prevent damage to engine, **DO NOT** use for any other purpose.
10. **Fuel Cock**– Controls the flow of diesel fuel to the carburetor. Must be in the ON position when starting and running the engine.

## CAUTION

**NEVER** operate the compactor in a confined area or enclosed area structure that does not provide ample **free flow of air**.



**ALWAYS** wear approved eye and hearing protection before operating the compactor.



### Before Starting

1. Read safety instructions at the beginning of manual.
2. Familiarize yourself with the operating and control elements of the machine and the working environment. This includes obstacles in the working area, bearing capacity of the ground and the necessary safety provisions.
3. Check the air filter for dirt and dust. If air filter is dirty, replace air filter with a new one as required.
4. Check fastening nuts and bolts for tightness. Loose threads may cause damage to the machine when vibrating.
5. Understand the geographical features and regulations of the job site.
6. Clean the compactor, removing dirt and dust. Particularly, the bottom of the plate, engine cooling air inlet.



### Checking Engine Oil Level

1. To check the engine oil level, place the compactor on secure level ground with the engine stopped.
2. Remove the dipstick from the engine oil filler hole (Figure 6) and wipe it clean.
3. Insert and remove the dipstick without screwing it into the filler neck. Check the oil level shown on the dipstick.

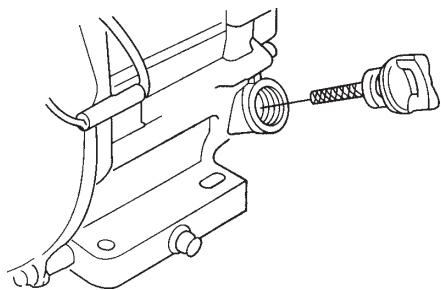

Figure 6. Engine Oil Dipstick Removal

4. If the oil level is low (Figure 7), fill to the edge of the oil filler hole with the recommended oil type (Table 4). Maximum oil capacity is 1.16 quarts (1.10 liters).

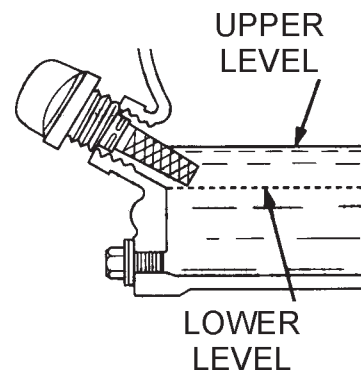

Figure 7. Engine Oil Level

Table 4. Oil Type

Season	Temperature	Oil Type
Summer	25°C or Higher	SAE 10W-30
Spring/Fall	25°C~10°C	SAE 10W-30/20
Winter	0°C or Lower	SAE 10W-10

### Checking the Hydraulic Oil Level

1. To check the engine oil level, place the compactor on secure level ground with the engine stopped.
2. Remove the hydraulic oil breather cap located at the top of the hydraulic oil tank (Figure 8).
3. Using a 24 mm wrench, remove the hydraulic oil filler plug.
3. Visually inspect to determine if hydraulic oil level is low. If oil level is low add Shell Tellus 46 hydraulic oil or equivalent through the hand pump oil filler port.

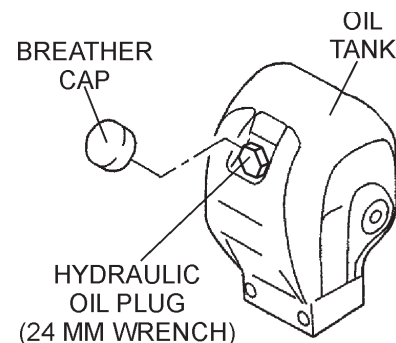

Figure 8. Hydraulic Oil Filler Plug Removal

## CAUTION

**DO NOT** overfill hydraulic oil tank. This could cause oil leaks and sluggish operation. Clean cap and surrounding area before opening to prevent dirt from entering oil tank.

- When adding hydraulic oil, only fill to the specified oil level as marked on the front of the hydraulic oil tank (Figure 9). **DO NOT** overfill



Figure 9. Oil Tank (Front View)

## Checking the Air Cleaner

- To check the engine oil level, place the compactor on secure level ground with the engine stopped.
- Loosen the wing nut (Figure 10), remove the air cleaner cover.

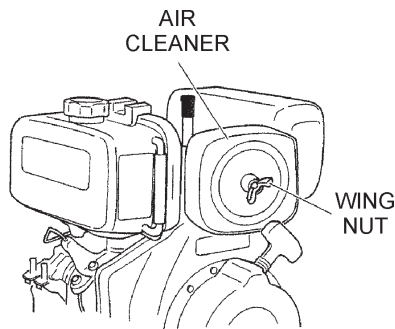

Figure 10. Air Cleaner Element

- Remove the air cleaner element (Figure 11) and inspect it for signs of wear or dirt. If air cleaner element is dirty, clean or replace element.

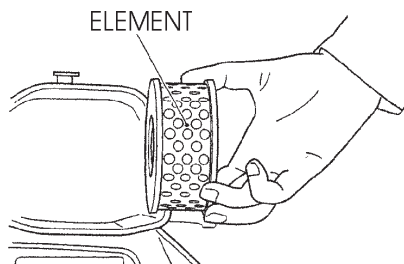

Figure 11. Air Cleaner Element

## Explosive Fuel

## DANGER



Diesel fuel is highly flammable and can be dangerous if mishandled. **DO NOT** smoke while refueling. **DO NOT** attempt to refuel the compactor if the engine is **hot!** or **running**.

## Checking The Fuel

- Remove the fuel cap located on top of fuel tank.
- Visually inspect to see if fuel level is low. If fuel is low, replenish with diesel fuel (Figure 12).
- When refueling, be sure to use a strainer for filtration. **DO NOT** top-off fuel. Wipe up any spilled fuel.

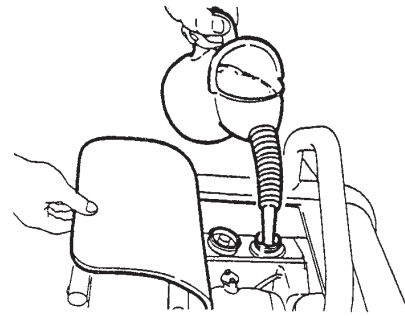

Figure 12. Refueling

## DANGER

Fuel spillage on a hot engine can cause a **fire** or **explosion**. If fuel spillage occurs, wipe up the spilled fuel completely to prevent fire hazards. **NEVER!** smoke around or near the compactor.



## CAUTION

**DO NOT** attempt to operate the compactor until the Safety, General Information and Inspection sections of this manual have been **read and thoroughly understood**.



This section is intended to assist the operator with the **initial start-up** of the compactor. It is extremely important that this section be read carefully before attempting to use the compactor in the field.

Refer to Figure 3 for the location of controls and components.

### Releasing the Handle

1. Pull the handle release pin, (Figure 13) then push down on the hand grip to release the handle.

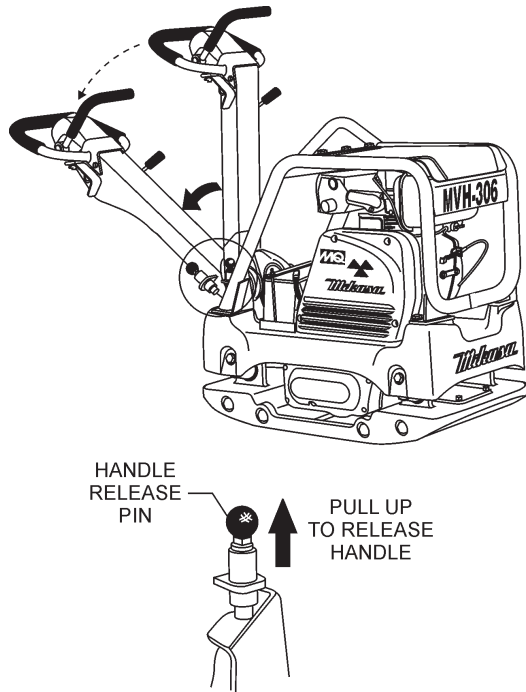

Figure 13. Handle Release Pin

### Adjusting Handle Height

The height of the handle is adjustable for your comfort.

1. Loosen the butterfly screw (Figure 14).
2. Turn the grip clockwise to raise the handle or counterclockwise to lower the handle.
3. When the handle is raised to the desired height, tighten the butterfly screw.

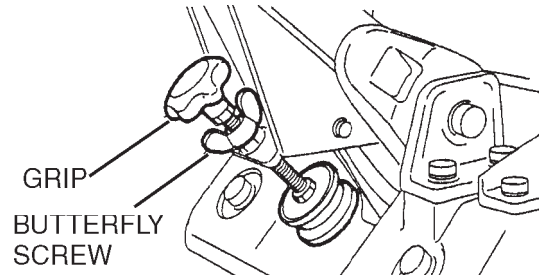

Figure 14. Handle Adjustment

## STARTING THE ENGINE

### Electric Start (Option)

1. Open the fuel cock (Figure 15).

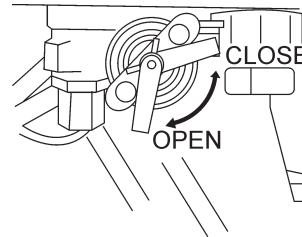

Figure 15. Open Fuel Cock

2. Place the **throttle lever** (Figure 16) in the **START** position (center). Place the **travel lever** in the neutral position (center)

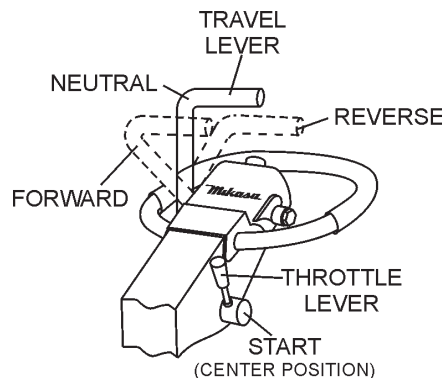

Figure 16. Travel/Throttle Lever (Start Positions)

3. Insert the ignition key into the ignition switch and turn it to the **RUN** position (Figure 17). The buzzer should sound at this time.
4. Turn the ignition key further to the right to the **START** position to start the engine. Buzzer stops sounding and the engine starts.

- If the engine fails to start, **DO NOT** continue to rotate the ignition key for more than 5 seconds. Return the key to the **RUN** position and wait 10 seconds before starting again

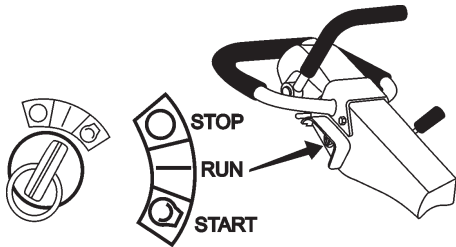
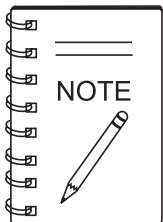

Figure 17. Starter Switch (Option)

## CAUTION

While the engine is running, never try to turn the ignition key to the **START** position.

- After starting the engine, continue to warm up the engine for about 3 to 10 seconds especially in cold weather.
- If the buzzer does not stop sounding after the engine has started, shutdown engine immediately and check engine oil level. The buzzer functions as a engine oil level alarm warning device.



When starting a unit with an electric start capability, a decompressor is not normally required. However, when ambient temperature or battery charger level is low, use of a decompressor will help make the start-up easier.

## Recoil Start

- Open the fuel cock (Figure 15).
- Move the throttle lever to the **START** position (Figure 16).
- Grasp the starter grip (Figure 18) and slowly pull it out. The resistance becomes the hardest at a certain position, corresponding to the compression point. Pull the starter grip briskly and smoothly for starting.

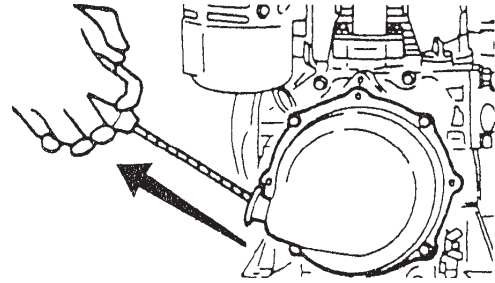

Figure 18. Engine Start Handle

- Push down decompression lever (Figure 19) and release.

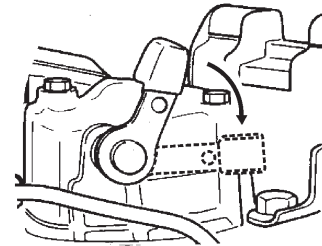

Figure 19. Decompression Lever

- If the engine does not start, repeat steps 4 and 5.

## TRAVELING

### CAUTION

Make sure to follow all safety rules referenced in the safety section of this manual before operating compactor. Keep work area clear of debris and other objects that could cause damage to the compactor or bodily harm.

- Grasp the compactor's hand grip (Figure 20), and move the engine throttle lever (Figure 20) quickly to the **fast** position.
- With the throttle lever in the fast position, the engine speed should be around 3,600 RPM, therefore engaging the centrifugal clutch

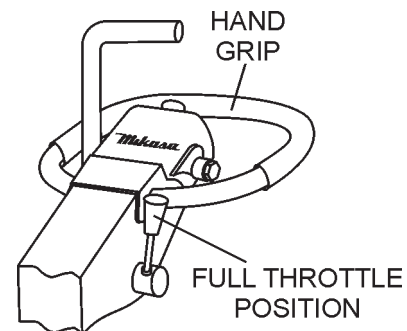

Figure 20. Throttle Lever (Fast)



**ALWAYS** move the throttle lever quickly without hesitation, because increasing the engine speed slowly causes the clutch to slip.

- To make the compactor move in the forward direction push the travel lever ( Figure 21) forward.

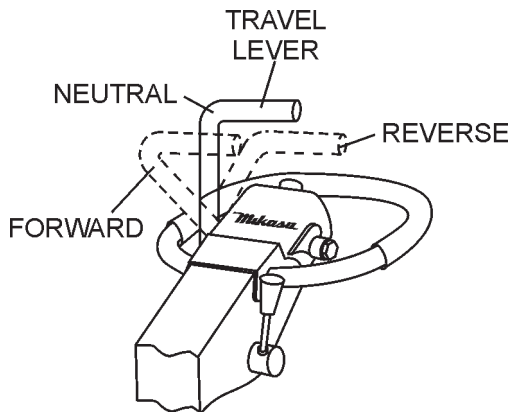

Figure 21. Travel Lever

- To make the compactor move in the reverse direction pull the travel lever ( Figure 21) backwards.
- Firmly gasp the compactor's hand grip, the compactor will begin moving in the desired position when the direction lever has been placed in the desired position.
- Slowly walk behind the compactor and be on the lookout for any large objects or foreign matter that might cause damage to the compactor or bodily injury.
- If travel lever is placed in the neutral position, the machine will vibrate in place.
- To move the compactor laterally, hold the hand grip firmly and swing compactor. **DO NOT** swing compactor while gripping the travel lever.

### Normal Shutdown

- Return the throttle lever to the **START** position (Figure 16). Allow the machine to cool down for 2 to 3 minutes.
- Place the travel lever in the **NEUTRAL** position.
- Place the throttle lever in the **STOP** position (Figure 22) to stop the engine. If using an electric start unit, return the key switch to the **STOP** position (Figure 23) as soon as the engine stops.
- Close the fuel cock (Figure 15).

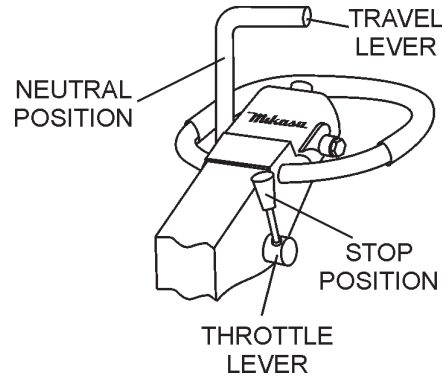

Figure 22. Throttle Lever (Stop)

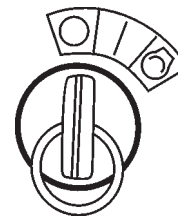

Figure 23. Starter Switch (STOP)

### Emergency Shutdown

- For a recoil start type engine, move the throttle lever quickly to the **STOP** position.
- For a electric start type engine, place the engine **IGNITION** switch in the **OFF** position.

### STOWING THE HANDLE

- Push up the handle upward (Figure 24) until the handle locks in place.

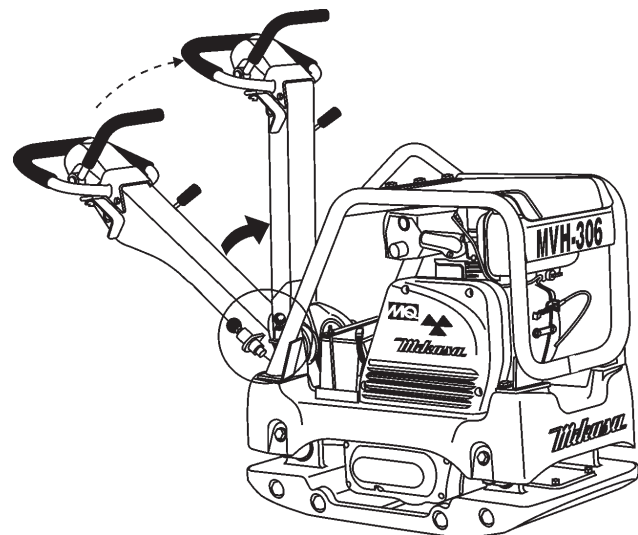

Figure 24. Stowing the Handle

**CAUTION**

Inspection and other services should **always** be carried out on hard and level ground with the engine shutdown.

**Inspection and Maintenance Service Tables.**

- To make sure your plate compactor is always in good working condition before using, carry out the maintenance inspection in accordance with Tables 5 through 7.

**TABLE 5. MVH-306DS2 MACHINE INSPECTION**

ITEM	HOURS OF OPERATION
Loose or Missing Screws	Every 8 hours (every day)
Damaged Parts	Every 8 hours (every day)
Function of Controlling System Part	Every 8 hours (every day)
Hydraulic System Leak	Every 100 hours
Vibrator Oil Check	Every 100 hours
Vibrator Oil Replacement	Every 300 hours
Hydraulic Oil Check	Every 100 hours
Hydraulic Oil Replacement	First after 200 hours, then every 1,000 hours
V-belt (clutch) Check	Every 200 hours
Battery Check	Every 100 hours

**CAUTION**

These inspection intervals are for operation under normal conditions. Adjust your inspection intervals based on the number hours plate compactor is in use, and particular working conditions.

**CAUTION**

Fuel piping and connections should be replaced every 2 years.

**TABLE 6. MVH-306DS2 ENGINE CHECK**

ITEM	HOURS OF OPERATION
Oil or Fuel Leak	Every 8 hours (every day)
Tightness of Fastening Threads	Every 8 hours (every day)
Engine Oil Check and Replenishment	Every 8 hours (every day) (Replenish to specified maximum level)
Engine Oil Replacement	After first 25 hours then every 50 to 100 hours
Air Filter Cleaning	Every 100 hours
See separate engine manual for details on engine check.	

**Daily Service**

- Check for leakage of fuel or oil.
- Check for loose screws including tightness. See Table 7 below (tightening torque ), for retightening:

**TABLE 7. TIGHTENING TORQUE (in. kg/cm) Diameter**

Material	6mm	8mm	10mm	12mm	14mm	16mm	18mm	20mm
4T	70	150	300	500	750	1,100	1,400	2,000
6-8T	100	250	500	800	1,300	2,000	2,700	3,800
11T	150	400	800	1,200	2,000	2,900	4,200	5,600
*	100	300~ 350	650 ~ 700					

\* (In case counter-part is of aluminum)  
(Threads in use with this machine are all right handed)  
Material and quality of material is marked on each bolt, and screw.

- Remove soil and clean the bottom of compaction plate.
- Check hand pump, piping and hose for any leakage. A loosened hydraulic hose can be a cause for leakage. Check hydraulic hose connections with wrench applied for tightness.
- Check engine oil.

## Engine Oil Replacement:

1. Replace engine oil, in first 25 hours of operation and every 50 to 100 hours afterwards.
2. Oil may be drained more easily when it is warm after operation (For more details, see separate engine Owner's Manual).

## Air Filter (Every 6 Months or 400 Hours)

1. The air filter element should be cleaned because a clogged air cleaner can cause poor engine starting, lack of power and shorten engine life substantially.

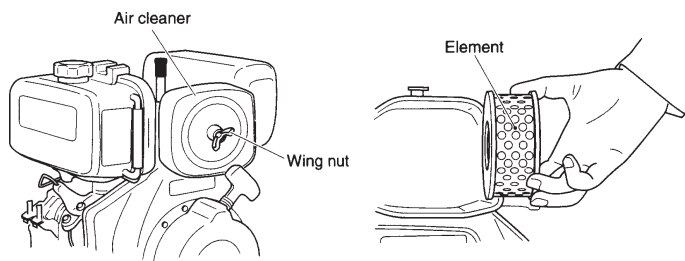
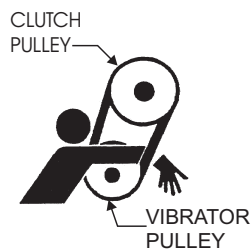

**Figure 25. Engine Air Filter and Element**

2. To clean or replace air filter loosen the wing nut on the air filter housing (Figure 25) remove the cover and take out air filter cartridge. If only cleaning of the air filter is desired blow through the air filter cartridge from the inside, moving a jet of dry compressed air up and down until all dust is removed.

## CAUTION

**NEVER** attempt to check the V-belt with the engine running. Severe injury can occur if your hand gets caught between the V-belt and the clutch (Figure 26). Always use safety gloves.



**Figure 26 V-Belt Hazard**

## Checking and Replacing the V-Belt and Clutch

1. After 200 hours of operation, remove the belt cover to check the V-belt tension (Figure 27). Tension is proper if the belt bends about 3/8" (10 mm) when depressed strongly with finger between shafts. Loose or worn V-belts reduces power transmission efficiency, causing weak compaction and reduces the life of the belt itself.

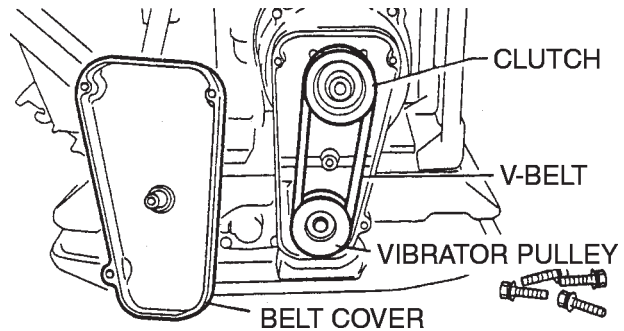

**Figure 27. V-Belt Check**

### ● Replacing the V-belt

Remove the belt cover. Engage an offset wrench 3/4" (19 mm) or the like to vibrator pulley (lower) fastening bolt. Engage waste cloth or the like at midway of V-belt on the left side and while pulling it back strongly, rotate the offset wrench clockwise so that the V-belt will come off.

### ● Reinstalling the V-belt

Engage V-belt to lower vibrator pulley and push the V-belt to left side of upper clutch and, in the same manner as in removal, rotate offset wrench clockwise so that the V-belt goes back on.

### ● Checking Clutch

Check the clutch simultaneously with V-belt checking. With belt cover removed, check outer drum of the clutch for seizure and "V" groove for wear or damage with your eyes. Clean the "V" groove as necessary. If the shoe is worn, power transmission becomes deficient and slipping will result.

### ● Replacing Clutch

Remove V-belt. Remove bolt at engine power output by giving a light tap with a hammer to an engaged wrench and rotate bolt counterclockwise. Remove clutch with a pulley extractor. To reinstall, reverse the procedure.

## CAUTION

Whenever the compactor's vibration becomes weak or lost during normal operation regardless of operation hours, check the V-belt and clutch immediately.

## Vibrator Oil Level Check

### CAUTION

Always clean the area around the vibrator oil level check plug before removing oil check plug. This will prevent dirt and debris from entering the system.

1. In every 100 hours of operation, with the machine positioned horizontally, use a 3/4" (19 mm) wrench and remove vibrator oil level check plug (Figure 28). Visually inspect and see if vibrator oil level is up to filler port. Be sure to clean area around check hole to prevent dirt and dust from entering.

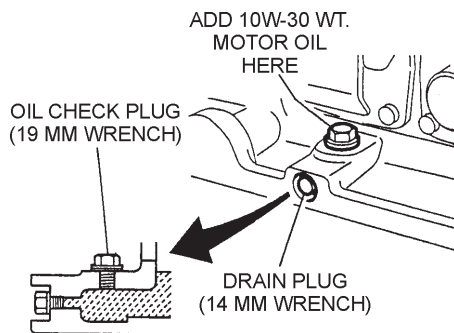

**Figure 28. Vibrator Oil Drain and Check Plugs**

### Draining Vibrator Oil

1. Replace vibrator oil after first 200 hours and in every 1,000 hours of operation.
2. Position handle bar vertically (storage position).
3. Using a 14 mm wrench remove the vibrator oil drain plug (Figure 28) from the vibrating plate assembly.

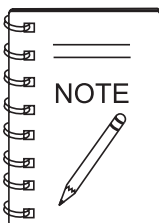

For draining oil through level check hole, have the machine inclined with a sleeper or the like placed under the compaction plate on opposite side.

4. After hydraulic oil has been completely drained from machine, fill with 10W-30 motor oil to the appropriate safe operating level (Figure 28)
5. Reinstall drain plug into vibrating plate assembly. Apply seal tape or Loctite #575 to thread portion of drain plug.

### Draining Hydraulic Oil

1. Disconnect the hydraulic hose (Figure 29) connected to the hydraulic oil cylinder.

2. Push the travel lever back and forth to drain the hydraulic oil from the hand pump (hydraulic oil reservoir).

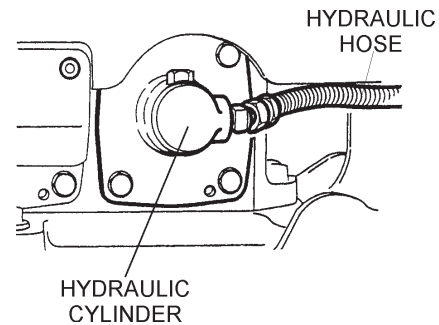
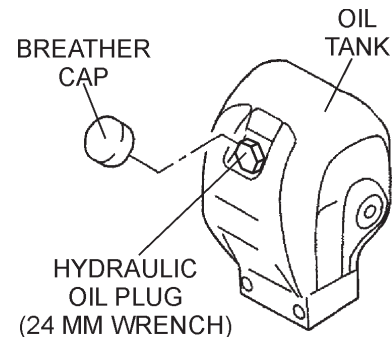

**Figure 29. Hydraulic Oil Cylinder/Hose**

3. After draining hydraulic oil, reconnect hydraulic oil hose to cylinder.
4. Place handle in upright position. Pull travel lever all the way back (reverse), and using a rope, secure travel lever to hand grip.

### Adding Hydraulic Oil

1. Remove the breather cap and oil plug (Figure 30) from the hydraulic oil tank using a 24mm hex socket.



**Figure 30. Hydraulic Oil Tank**

2. Using a funnel, add **ShellTellus Oil #46** or equivalent to the hydraulic oil tank through the oil filler port (Figure 31). Oil tank capacity is 50.7 fl. oz (1500 cc)

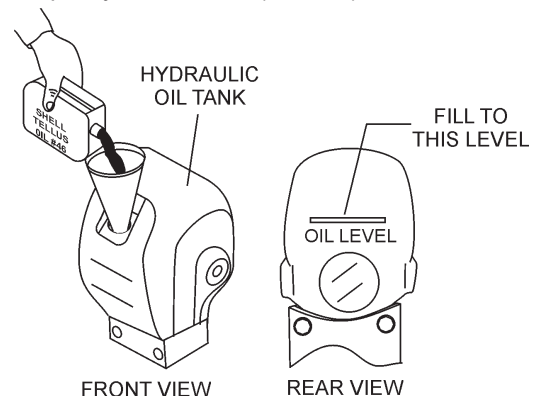

**Figure 31. Hydraulic Oil Maintenance**

## CAUTION

Make sure hydraulic oil is at a normal safe operating level. **DO NOT** over fill. Over filling (excessive oil) will cause excess oil to blow out of bleeder plug.

- Loosen bleeder plug located at top of hydraulic cylinder on side of vibrator (Figure 32). Air remaining in the circuit will be forced out of the bleeder plug. Once all air has been purged from the hydraulic system, tighten bleeder plug securely
- Reinsert oil plug into hydraulic oil tank and tighten securely. Reinstall breather cap.

## CAUTION

The **bleeder plug** should only be loosened, but not removed.

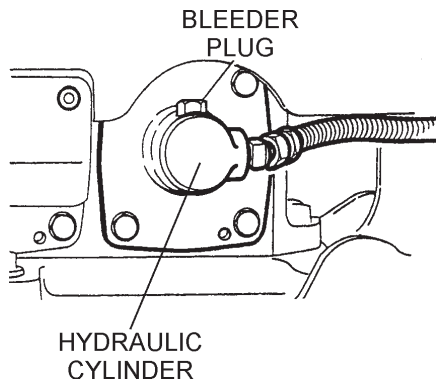

Figure 32. Bleeder Plug

## BATTERY MAINTENANCE (Option)

Mishandling of the battery shortens the service life of the battery and adds to maintenance cost. When handling the battery do the following:

## CAUTION

Wear **safety glasses** or **face mask**, **protective clothes**, and **rubber gloves** when working with battery.



- The battery electrolyte contains sulfuric acid, be careful not to let the battery electrolyte come in contact with your body or clothing.
- Always check the battery terminals periodically to ensure that they are in good condition.

- Always wear **eye protection** and **rubber gloves**, since the battery contains sulfuric acid which burns skin and eats through clothing. In case of contact, flush thoroughly with water and contact a doctor immediately.
- Use wire brush or sand paper to clean the battery terminals.
- Always check battery for cracks or any other damage. If white pattern appears inside the battery or paste has accumulated at the bottom, replace the battery.
- If the compactor will not be in operation for a long period of time, store in cool dry place and check the battery charge level every month to maintain the performance of the battery.
- Check the battery regularly and make sure that each electrolyte level is to the bottom of the vent well (Figure 33). If necessary add only distilled water in a well-ventilated area.

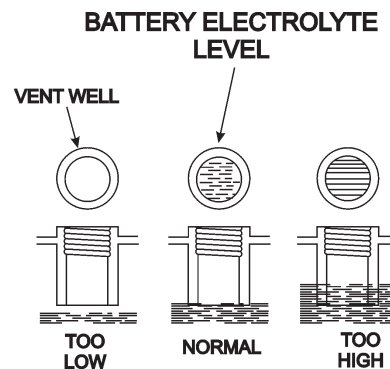



Figure 33. Battery Electrolyte Levels

## BATTERY CHARGING

- DO NOT** charge battery with the battery cables connected to the compactor. The diodes will be damage by the high voltage.
- Batteries generate hydrogen gas which can be highly explosive. **DO NOT** smoke or allow flames or sparks near the battery, especially during charging of the battery.  
- Charge the battery in a open air environment (plenty of ventilation).
- Before charging , remove the cap from each cell of the battery.
- Connect the positive (+) lead of the charger to the positive (+) terminal of the battery and the negative (-) lead of the charger to the negative (-) terminal of the battery. **DO NOT** reverse the polarity when charging. Reverse polarity will damage the charger rectifier or the battery.

- Battery fluid will be lost through continuous charging and discharging.
- Discontinue charging if the electrolyte temperature exceeds 117° F (45° C)



During summer much more battery fluid is lost than in winter. Before starting check battery electrolyte levels, and replenish with distilled water to the upper mark on the battery.

## BATTERY CABLE CONNECTION (Option)

1. Take off the battery cover by removing the M6 nuts (Figure 32).
2. When removing cable, disconnect the ground side (normally negative) first (Figure 34).
3. When installing cable connect the ground side (normally negative) last.

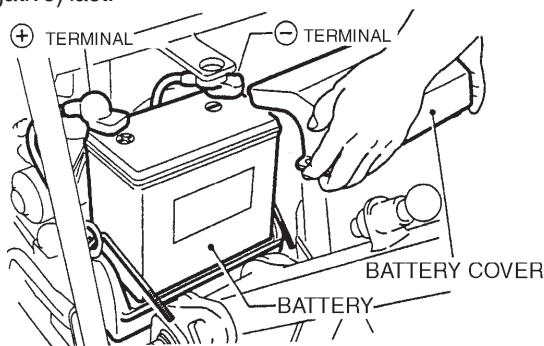

Figure 34. Battery Removal

## CHECKING FUEL FILTER

1. Clean the fuel filter (Figure 35) every 3 months or 200 hours.
2. Replace fuel filter every 6 months or 400 hours.
3. To clean the fuel filter, loosen the nuts of the fuel cock and pull out the filter from the F.O. tank filler port. Wash the filter thoroughly with diesel fuel oil.
4. Reinstall fuel filter and connect all associated hardware.

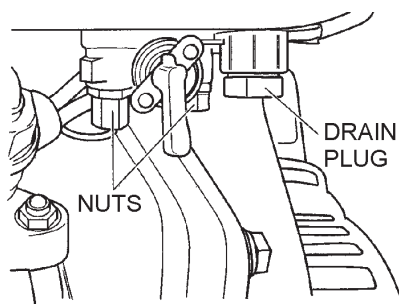

Figure 35. Fuel Filter

## LONG TERM STORAGE

When storing your compactor for long periods do the following:

- Run the engine at idle speed for 3-5 minutes.
- Stop the engine. Drain the engine crankcase oil while the engine is still warm. Fill Engine crankcase with fresh oil.
- Remove the rubber plug (Figure 36) on the rocker arm cover and add about 2 cc of lube oil. Reinstall rubber plug.

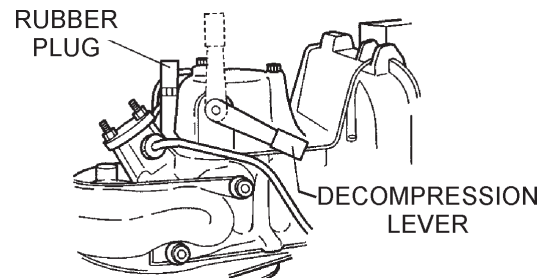

Figure 36. Decompression Lever

- For recoil type compactors, push the decompression down (non-decompression position) and hold it while you pull the recoil starter grip (Figure 37) rope 2 or 3 times. **DO NOT** start the engine.

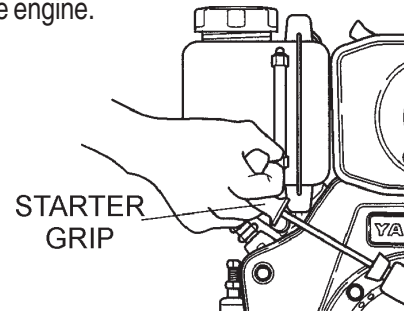

Figure 37. Recoil Starter Grip

- For electric start type compactors, turn the engine for 2 or 3 seconds with the decompression lever set in the non-decompression position, and the starter key at the **START** position. **DO NOT** start the engine.
- Pull the decompression lever up. Pull the recoil starter grip slowly. **STOP** when it feels tight. This closes the intake and exhaust valves (compression position), and helps prevents ruts from forming.
- Wipe any oil or dirt that may have accumulated on the compactor.
- Store compactor in a cool dry place out of the reach of children or unauthorized personnel

## Troubleshooting

See Tables 8 (engine) and 9 (plate compactor) on proceeding pages for engine and plate compactor troubleshooting guide.

# MVH-306DS2 —TROUBLESHOOTING

Practically all breakdowns can be prevented by proper handling and maintenance inspections, but in the event of a breakdown, please take a remedial action following the

diagnosis based on the Engine Troubleshooting (Table 8) information shown below. If the problem cannot be remedied, please leave the unit just as it is and consult our company's business office or service plant.

**TABLE 8. ENGINE TROUBLESHOOTING**

SYMPTON	POSSIBLE PROBLEM	SOLUTION
Engine will not start or start is delayed, although engine can be turned over.	Speed control lever is in "STOP" position?	Set speed control lever to "START" position.
	No fuel reaching injection pump?	Add fuel. Check entire fuel system.
	Defective fuel pump?	Replace fuel pump.
	Fuel filter clogged?	Replace fuel filter and clean tank.
	Faulty fuel supply line?	Replace or repair fuel line.
	Compression too low?	Check piston, cylinder and valves. Adjust or repair per engine repair manual.
	Fuel injector not working correctly?	Repair or replace injector in accordance with engine repair manual.
	Oil pressure too low?	Check engine oil pressure.
At low temperatures engine will not start.	Low starting temperature limit exceeded	Comply with cold starting instructions and proper oil viscosity.
	Fuel separates has inadequate resistance to low temperatures?	Check whether clear (not turbid) fuel emerges from the fuel line (detach from injection pump). If the fuel is turbid or separated, warm up the engine or drain the complete fuel supply system. Refuel with winter grade diesel fuel.
Engine oil too thick?		Refill engine crankcase with correct type of oil for winter environment.
Engine fires but stops soon as starter is switched off.	Throttle lever in STOP position?	Reposition throttle lever to RUN position.
	Fuel filter blocked?	Replace fuel filter.
	Fuel supply blocked?	Check the entire fuel system.
Engine stops by itself during normal operation.	Fuel tank empty?	Add fuel.
	Fuel filter blocked?	Replace fuel filter.
Low engine power, output and speed.	Fuel tank empty?	Fill with No.2 diesel fuel.
	Fuel filter clogged?	Replace fuel filter.
	Fuel tank venting is inadequate?	Ensure that tank is adequately vented.
	Speed control lever does not remain in selected position?	See engine manual for corrective action.
	Engine oil level too full?	Correct engine oil level?
Low engine power output and low speed, black exhaust smoke.	Air filter blocked?	Clean or replace air filter.
	Incorrect valve clearances?	Adjust valves per engine specification.
	Malfunction at injector?	See engine manual.

# MVH-306DS2 —TROUBLESHOOTING

Practically all breakdowns can be prevented by proper handling and maintenance inspections, but in the event of a breakdown, please take a remedial action following the

diagnosis based on the Compactor Troubleshooting (Table 9) information shown below. If the problem cannot be remedied, please leave the unit just as it is and consult our company's business office or service plant.

**TABLE 9. TROUBLESHOOTING COMPACTOR**

SYMPTOM	POSSIBLE CAUSE	SOLUTION
Travel speed low and vibration weak.	Clutch slips?	Adjust or replace clutch.
	V-belt slips?	Adjust or replace V-belt.
	Excessive Oil in vibrator?	Fill to correct level..
	Trouble in vibrator internals?	Check vibrator assembly for any worn or defective parts, replace any defective parts.
	Aeration in hydraulic oil for for travel reversing syste.?	Purge air in hydraulic oil. (Bleed plug)
	Engine speed incorrect?	Set engine speed to correct RPM.
Travels forward or backward but unable to switch direction.	Travel reversing system inoperative.?	Check entire travel system.
	Reversing lever installation correct?	Clean installation of reversing lever.
	Broken or defective oil hose?	Replace oil hose.
	Aeration in hydraulic oil for for travel reversing syste.?	Purge air in hydraulic oil. (Bleed plug)
	Excessive oil in reversing system?	Fill to correct level..
	Selector valve clogged with trash?	Clean selector valve.
	Cylinder piston bearing failure?	Check piston bearing in cylinder for leakage at USH packing.
Does not travel in forward or reverse.	V-belt dis-engaged or slips?	Engage V-belt, adjust or replace.
	Clutch slips?	Adjust clutch, replace if necessary.
	Pump input shat key or adapter key-way damaged?	Replace input shatkey or adapter key-way
	Cylinder piston bearing failure?	Check piston bearing in cylinder for leakage at USH packing.
Reversing lever operating resistance great.	Excessive hydraulic oil?	Fill to correct level.

# MVH-306DS2 — EXPLANATION OF CODES IN REMARKS COLUMN

The following section explains the different symbols and remarks used in the Parts section of this manual. Use the help numbers found on the back page of the manual if there are any questions.

The contents and part numbers listed in the parts section are subject to change **without notice**. Multiquip does not guarantee the availability of the parts listed.

Sample Parts List:

NO.	PART NO.	PART NAME	QTY.	REMARKS
1	12345	BOLT .....	1	INCLUDES ITEMS W/*
2*		WASHER, 1/4 IN. ....		NOT SOLD SEPARATELY
2*	12347	WASHER, 3/8 IN. ...	1	MQ-45T ONLY
3	12348	HOSE .....	A/R	MAKE LOCALLY
4	12349	BEARING .....	1	S/N 2345B AND ABOVE

## NO. Column

**Unique Symbols** - All items with same unique symbol (\*, #, +, %, or >) in the number column belong to the same assembly or kit, which is indicated by a note in the "Remarks" column.

**Duplicate Item Numbers** - Duplicate numbers indicate multiple part numbers are in effect for the same general item, such as different size saw blade guards in use or a part that has been updated on newer versions of the same machine.



When ordering a part that has more than one item number listed, check the remarks column for help in determining the proper part to order.

## PART NO. Column

**Numbers Used** - Part numbers can be indicated by a number, a blank entry, or TBD.

TBD (To Be Determined) is generally used to show a part that has not been assigned a formal part number at time of publication.

A blank entry generally indicates that the item is not sold separately or is not sold by Multiquip. Other entries will be clarified in the "Remarks" Column.

## QTY. Column

**Numbers Used** - Item quantity can be indicated by a number, a blank entry, or A/R.

A/R (As Required) is generally used for hoses or other parts that are sold in bulk and cut to length.

A blank entry generally indicates that the item is not sold separately. Other entries will be clarified in the "Remarks" Column.

## REMARKS Column

Some of the most common notes found in the "Remarks" Column are listed below. Other additional notes needed to describe the item can also be shown.

**Assembly/Kit** - All items on the parts list with the same unique symbol will be included when this item is purchased.

Indicated by:

"INCLUDES ITEMS W/(unique symbol)"

**Serial Number Break** - Used to list an effective serial number range where a particular part is used.

Indicated by:

"S/N XXXXX AND BELOW"

"S/N XXXX AND ABOVE"

"S/N XXXX TO S/N XXX"

**Specific Model Number Use** - Indicates that the part is used only with the specific model number or model number variant listed. It can also be used to show a part is NOT used on a specific model or model number variant.

Indicated by:

"XXXXX ONLY"

"NOT USED ON XXXX"

**"Make/Obtain Locally"** - Indicates that the part can be purchased at any hardware shop or made out of available items. Examples include battery cables, shims, and certain washers and nuts.

**"Not Sold Separately"** - Indicates that an item cannot be purchased as a separate item and is either part of an assembly/kit that can be purchased, or is not available for sale through Multiquip.

## **MVH-306DS2 W/YANMAR L70V6 DIESEL ENGINE**

*1 to 3 Units*

<b>Qty.....</b>	<b>P/N .....</b>	<b>Description</b>
1 .....	956100054 .....	THROTTLE WIRE
2 .....	070200373 .....	V-BELT
3 .....	11425012580 .....	ELEMENT W/ PRE-FILTER
1 .....	16081076630 .....	STARTER ROPE
2 .....	11425055121 .....	FUEL FILTER W/GASKET
1 .....	11428855010 .....	CAP, FUEL TANK W/GASKET
1 .....	11425035110 .....	LUBE OIL STRAINER
1 .....	11425055100 .....	FUEL STRAINER
1 .....	955300680 .....	IGNITION SWITCH W/ KEY
3 .....	955000010 .....	KEY, IGNITION SWITCH

# MVH-306DS2 — NAMEPLATE AND DECALS

## NAMEPLATE AND DECALS

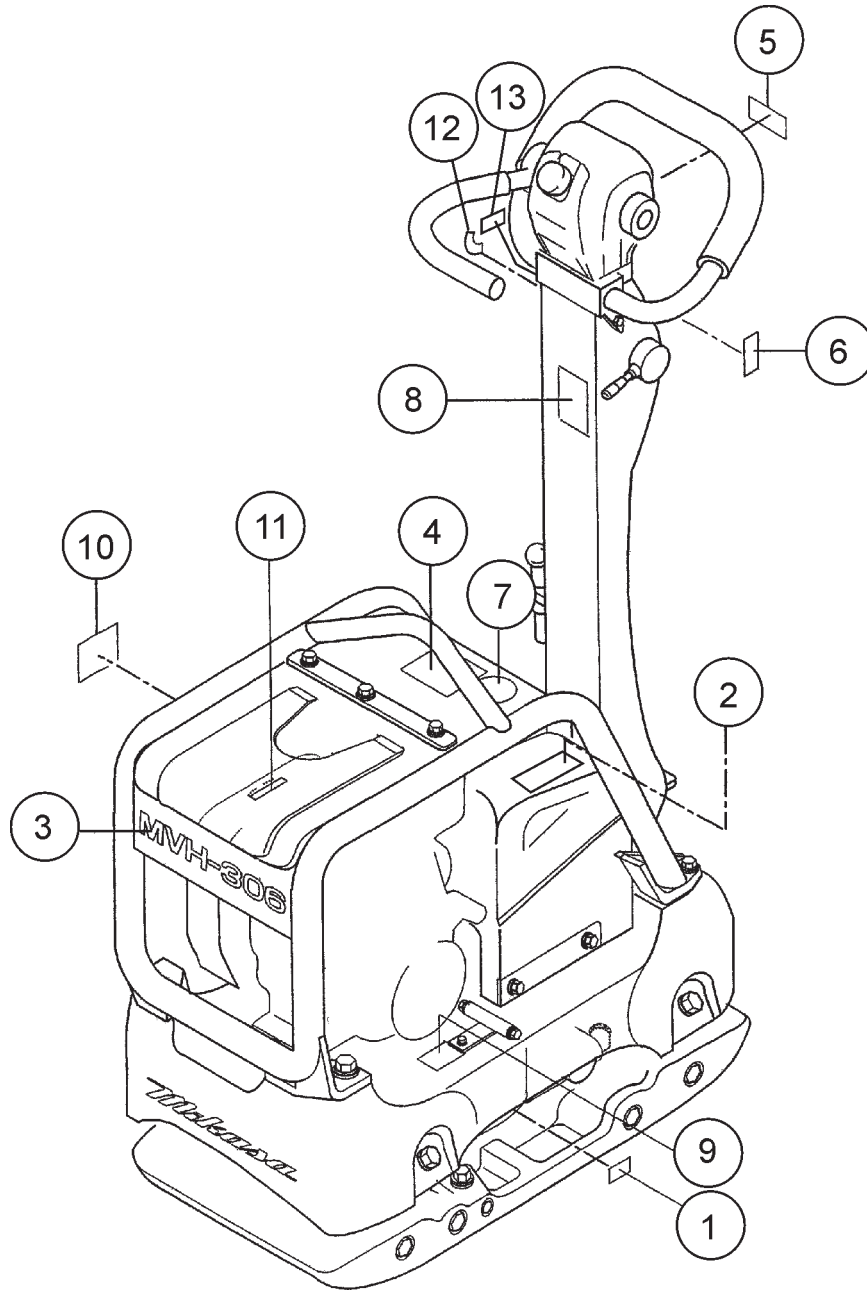

## MVH-306DS2 — NAMEPLATE AND DECALS

### NAMEPLATE AND DECALS

<u>NO.</u>	<u>PART NO.</u>	<u>PART NAME</u>	<u>QTY.</u>	<u>REMARKS</u>
1	920201950	DECAL: OIL SAE 10W-30	1	
2	920105070	DECAL: MIKASA LOGO .....	1	ELECTRIC START MODEL ONLY
3	920110370	DECAL: MODEL LOGO MVH-306	1	
4	920209620	DECAL: CAUTION	1	
5	920207480	DECAL: SHELL TELLUS OIL 46	1	
6	920204580	DECAL: FULL THROTTLE	1	
7	920203330	DECAL: EAR PROTECTION	1	
8	920211060	DECAL: CAUTION (TRAVEL LEVER)	1	
9	920206960	DECAL: SERIAL NO. ....	1	CONTACT MQ PARTS DEPT.
10	920201580	DECAL: MQ LOGO	1	
11	920211010	DECAL: V-BELT HDPF-5370	1	
12	920106760	DECAL: STOP-RUN-START	1	
13	0732004460	DECAL: STARTER SWITCH	1	

# MVH-306DS2 — VIBRATING PLATE ASSY.

VIBRATING PLATE ASSY.

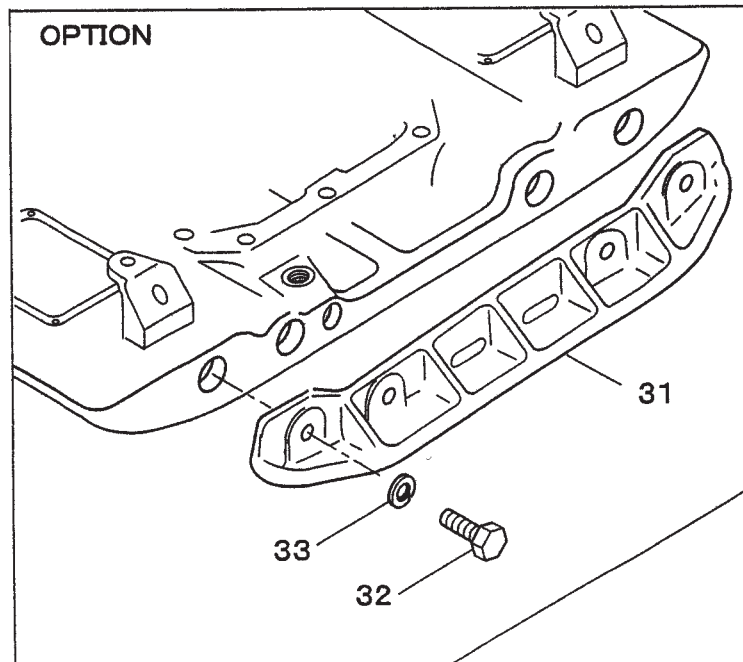
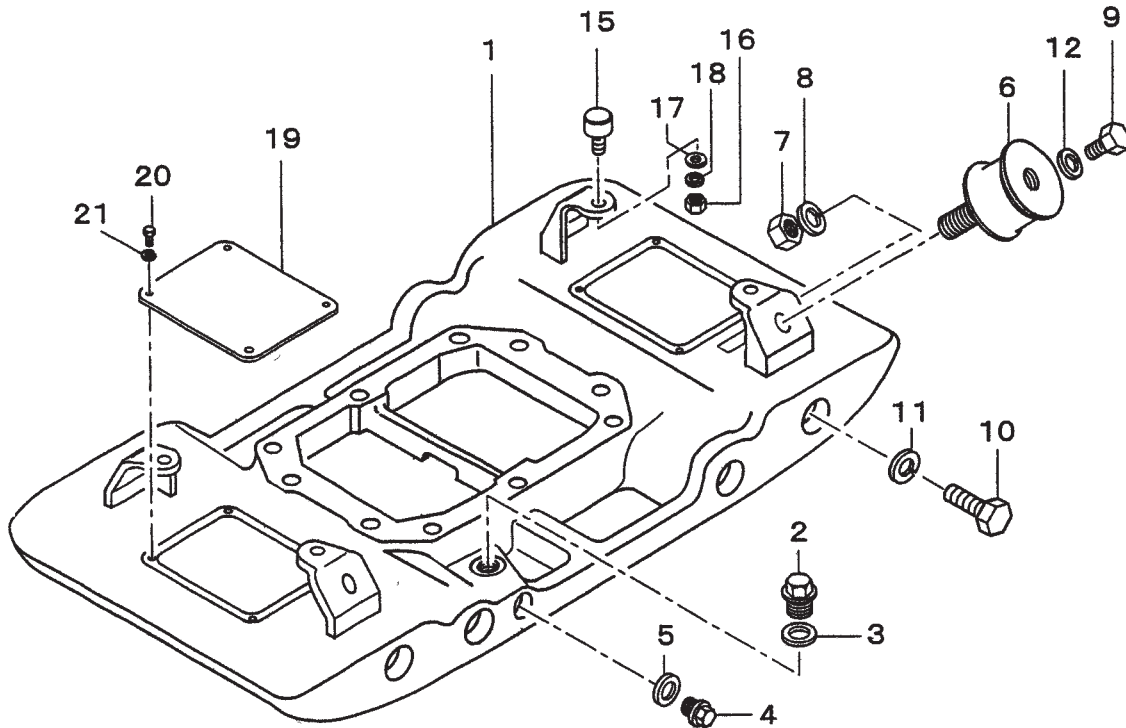

## MVH-306DS2 — VIBRATING PLATE ASSY.

### VIBRATING PLATE ASSY.

<u>NO.</u>	<u>PART NO.</u>	<u>PART NAME</u>	<u>QTY.</u>	<u>REMARKS</u>
1	464117840	VIBRATING PLATE	1	
2	953405840	DRAIN PLUG M18 (H)	1	
3	953402930	COPPER PACKING 19X30X1	1	
4	953400270	PLUG 1/4X14 10L	1	
5	953405260	PACKING 1/4 (CU)	1	
6	939010260	SHOCK ABSORBER 110X60H	4	
7	020316130	NUT M16	4	
8	030216400	WASHER, LOCK M16	4	
9	001221635	BOLT 16X35 T	4	
10	001221830	BOLT 18X30 T	8	
11	58407	WASHER, LOCK M18	8	
12	030216400	WASHER, LOCK M16	4	
15	939010010	SHOCK ABSORBER, STOPPER 45	4	
16	020310080	NUT M10	4	
17	031110160	WASHER, FLAT M10	4	
18	030210250	WASHER, LOCK M10	4	
19	464343730	COVER, VIBRATING PLATE	2	
20	011008015	BOLT 8X15 T	8	
21	030208200	WASHER, LOCK M8	8	
31	52993	EXTENSION PLATE	2	
32	012218050	BOLT 18X50 T	8	
33	58407	WASHER, LOCK M18	8	



## MVH-306DS2 — BASE AND ENGINE ASSY.

### BASE & ENGINE ASSY.

<u>NO.</u>	<u>PART NO.</u>	<u>PART NAME</u>	<u>QTY.</u>	<u>REMARKS</u>
1	464117850	BASE	1	
2	914410026	ENGINE ASSY. L70V6 (YANMAR)	1	
3	0105051045	BOLT 10X45 T	4	
4	030210250	WASHER, LOCK M10	4	
5	031110160	WASHER, FLAT M10	4	
6	464216560	BELT COVER (IN)	1	
7	011208025	BOLT 8X25 T	4	
8	030208200	WASHER, LOCK M8	4	
9	031108160	WASHER, FLAT M8	4	
10	464343670	DUST-PROOF SPONGE (IN)	1	
11	464457360	SPACER/MVH-306	1	
12	456343340	CLUTCH ASSY./CHM03/W.FAN	1	
13	951400110	KEY 7X7X35	1	
13-1	951406790	KEY 7X7X36 RR	1	
14	952400690	WASHER 9X35X4.5	1	
15	001220830	BOLT 8X30 T	1	
16	030208200	WASHER, LOCK M8	1	
17	464216640	DUST-PROOF COVER	1	
18	092006010	FLAT HEAD SCREW 6X10	3	
19	464343660	DUST-PROOF SPONGE (OUT)	1	
20	464216590	BELT COVER (OUT)	1	
21	001521050	SOCKET HEAD BOLT 10X50 T	4	
35	464117920	RUBBER COVER (GUARD FRAME)	1	
36	456449950	PLATE, COVER	1	
37	011208030	BOLT 8X30 T	1	
38	030208200	WASHER, LOCK M8	3	
39	031108160	WASHER, FLAT M8	3	
40	022710809	NYLON NUT M8	3	

# MVH-306DS2 — BASE AND ENGINE ASSY. (CONTINUED)

BASE AND ENGINE ASSY. (CONTINUED)

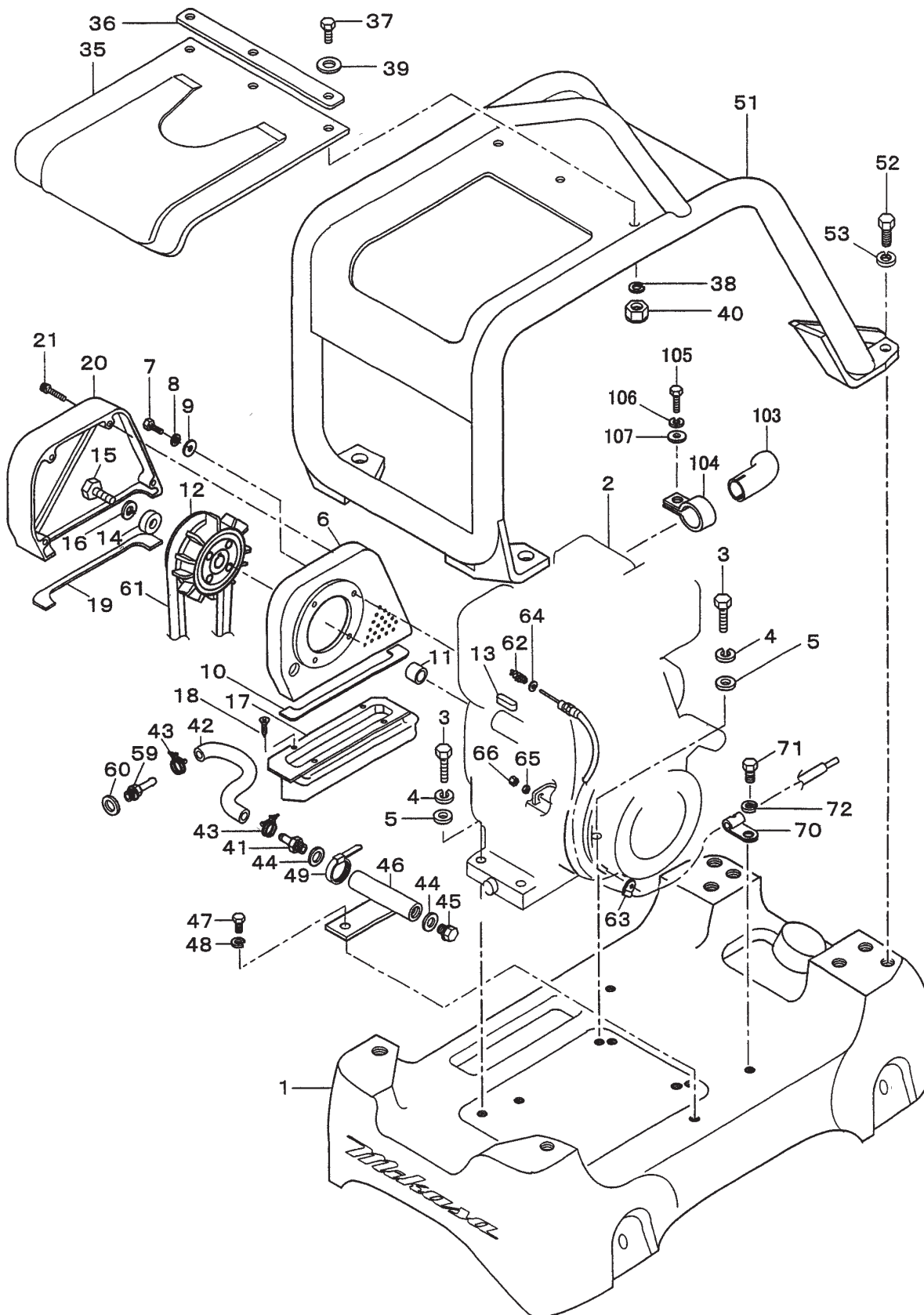

## MVH-306DS2 — BASE AND ENGINE ASSY. (CONTINUED)

### BASE AND ENGINE ASSY. (CONTINUED)

<u>NO.</u>	<u>PART NO.</u>	<u>PART NAME</u>	<u>QTY.</u>	<u>REMARKS</u>
41	459010060	UNION TIP, DRAIN	1	
42	459010070	DRAIN HOSE	1	
43	459010090	HOSE BAND	2	
44	459010080	GASKET (OIL DRAIN)	2	
45	0401140030	PLUG	1	
46	464457380	DRAIN JOINT	1	
47	014208020	BOLT 8X20 T	1	
48	030208200	WASHER, LOCK M8	1	
49	454010020	CLAMP TC-100	1	
51	464117910	GUARD HOOK	1	
52	012214030	BOLT 14X30 T	4	
53	030214350	WASHER, LOCK M14	4	
59	459455560	UNION, OIL DRAIN	1	
60	22190160002	SEAL WASHER 16S	1	
61	070200373	V-BELT	1	
62	2344600213	RETURN SPRING	1	
63	151010680	CLAMP CP.	1	
64	58151	WASHER, FLAT M5	1	
65	020406040	NUT M6, H=4.2	1	
66	959406800	NUT M6 (SPECIAL-L10)	1	
70	959407260	CLIP D6 (FOR M10)	1	
71	001221015	BOLT 10X15 T	1	
72	030210250	WASHER, LOCK M10	1	
103	464457600	EXHAUST DEFLECTOR	1	
104	2283720111	BAND CP	1	
105	001220620	BOLT 6X20 T	1	
106	030206150	WASHER, LOCK M6	1	
107	031106100	WASHER, FLAT M6	1	

# MVH-306DS2 — VIBRATOR ASSY.

VIBRATOR ASSY.

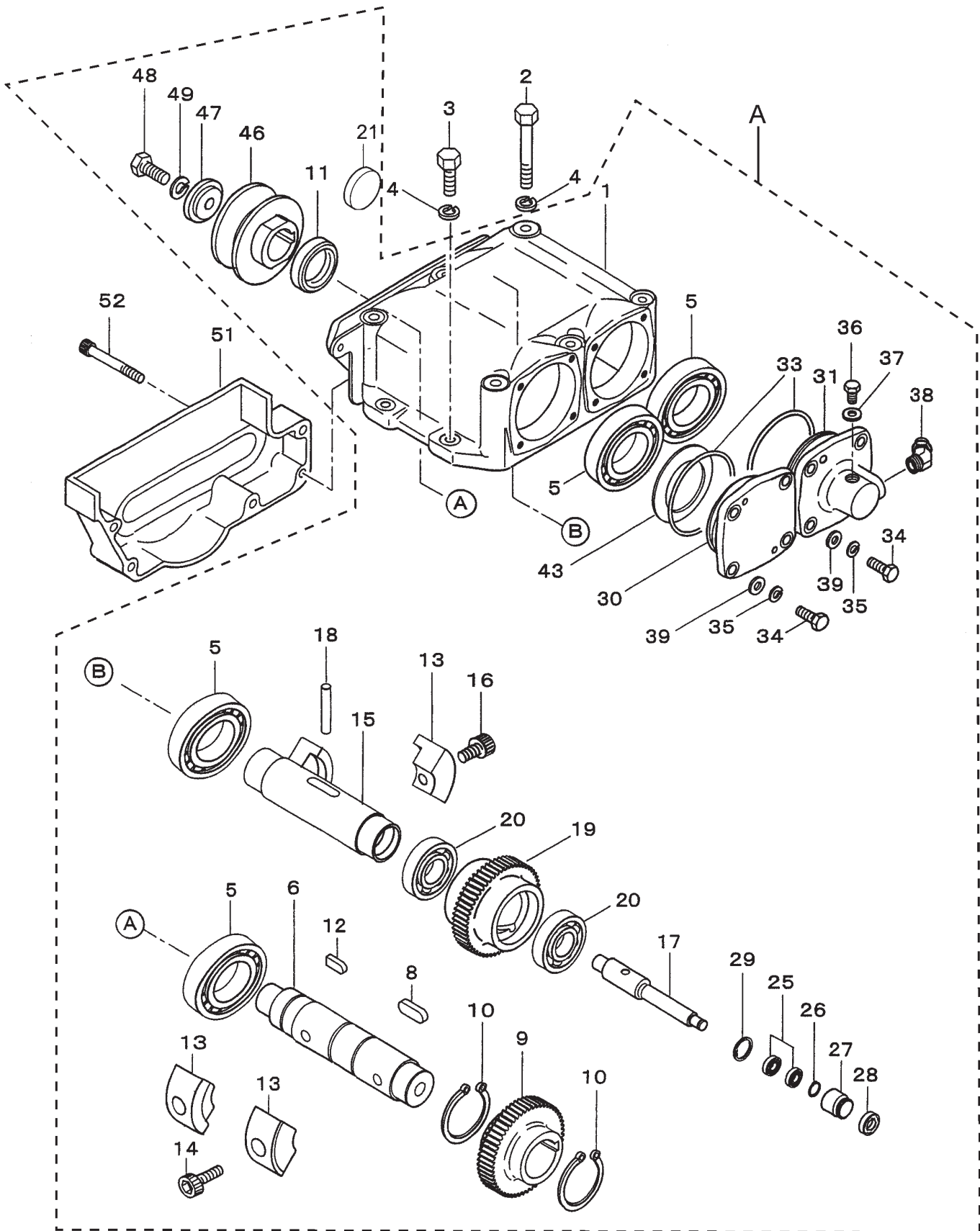

# MVH-306DS2 — VIBRATOR ASSY.

## VIBRATOR ASSY.

<u>NO.</u>	<u>PART NO.</u>	<u>PART NAME</u>	<u>QTY.</u>	<u>REMARKS</u>
A	464910020	VIBRATOR ASSY. ....	1	INCLUDES ITEMS W/ #
1#	464117880	VIBRATING CASE	1	
2	001221470	BOLT 14X150 T	6	
3	001221450	BOLT 14X50 T	4	
4	030214350	WASHER, LOCK M14	10	
5#	047920120	ROLLER BEARING NJ310EMC4	4	
6#	457212410	ROTARY SHAFT, DRIVE	1	
8#	951405370	KEY 15X10X39 RR	1	
9#	456327150	GEAR, DRIVE	1	
10#	080200550	STOP RING S-55	2	
11#	060105030	OIL SEAL SB-50729	1	
12#	951404970	KEY 12X8X30 R	1	
13#	464343700	ECCENTRIC ROTATOR	4	
14#	009120301	SOCKET HEAD BOLT 16X40 T	2	
15#	456337670	ROTARY SHAFT, DRIVEN	1	
16#	009120302	SOCKET HEAD BOLT 16X30 T	2	
17#	456337380	PISTON ROD	1	
18#	456010010	KNOCK PIN 10X70	1	
19#	464343720	GEAR (DRIVEN)	1	
20#	040006911	BEARING 6911	2	
21#	953010030	SEAL CAP/SC72-8N	1	
25#	042506000	BEARING 6000ZZSG	2	
26#	080200100	STOP RING S-10	1	
27#	455435051	PISTON, 22.4D	1	
28#	455010070	PACKING USH-22.4X30X5	1	
29#	080100260	STOP RING R-26	1	
30#	456327130	BEARING COVER	1	
31#	456210636	CYLINDER (L)/(AC)	1	
33#	050101050	O-RING G-105	2	
34#	001221025	BOLT 10X25 T	8	
35#	030210250	WASHER, LOCK M10	8	
36#	011008015	BOLT 8X12 T	1	
37#	953404600	COPPER PACKING 8X16X2	1	
38#	455010020	ELBOW 45 DEG. 15-0404	1	
39#	031110160	WASHER, FLAT M10	4	
43#	952405470	SHIM 90X110X0.5	2	
46#	464343710	PULLEY	1	
47#	464457370	WASHER	1	
48#	012212030	BOLT 12X30 T	1	
49#	030212300	WASHER, LOCK M12	1	
51	464216600	BELT COVER (LOWER)	1	
52	001520852	SOCKET HEAD BOLT 8X60 T	5	

# MVH-306DS2 — CONTROL HANDLE ASSY.

## CONTROL HANDLE ASSY.

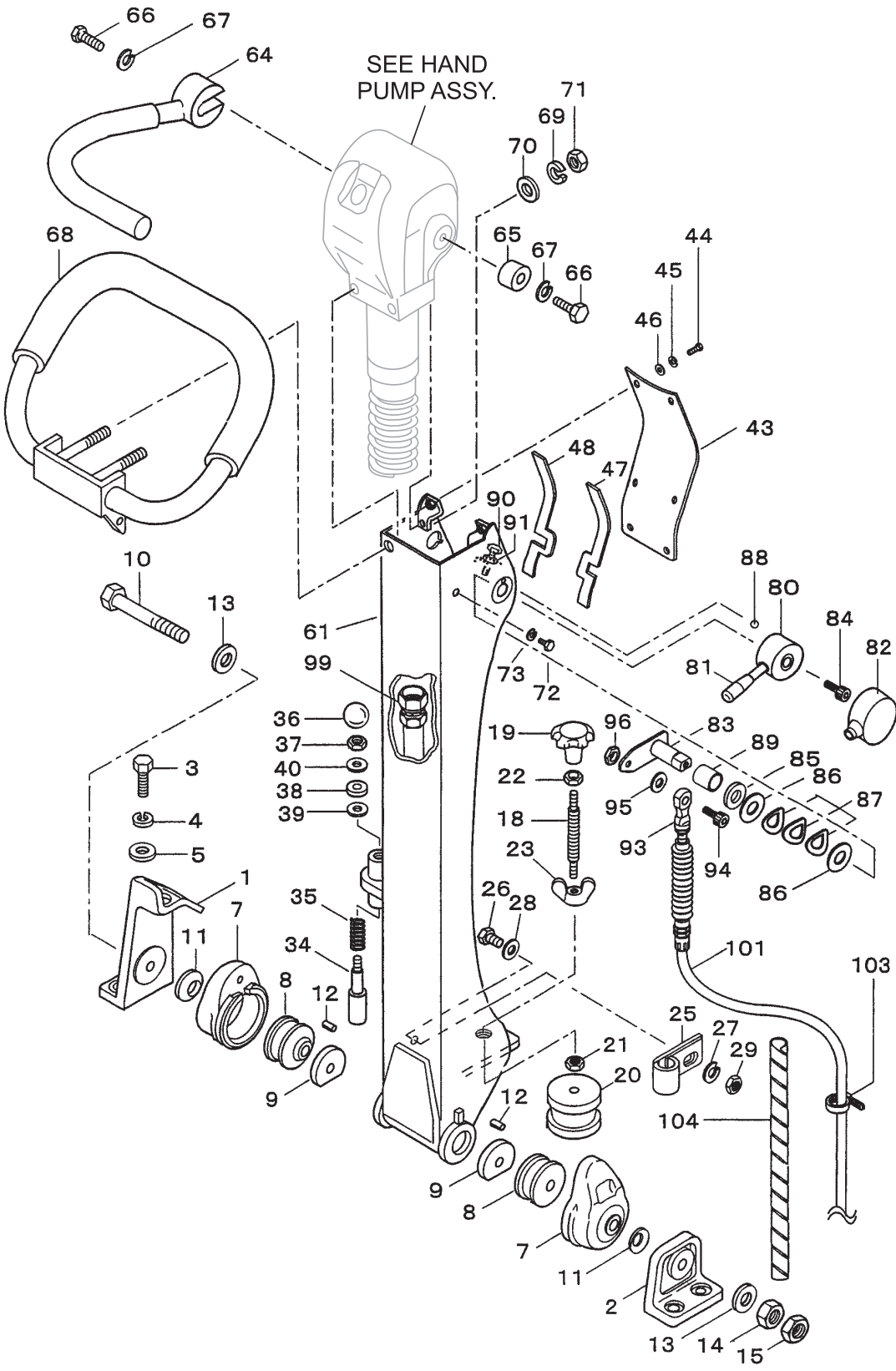

## MVH-306DS2 — CONTROL HANDLE ASSY.

### CONTROL HANDLE ASSY.

<u>NO.</u>	<u>PART NO.</u>	<u>PART NAME</u>	<u>QTY.</u>	<u>REMARKS</u>
1	464343680	HANDLE BRACKET	1	
2	456336420	HANDLE BRACKET (R)	1	
3	012212035	BOLT 12X35 T	4	
4	030212300	WASHER, LOCK M12	4	
5	031112230	WASHER, FLAT M12	4	
7	456336400	RUBBER COUPLING	2	
8	456449940	SHOCK ABSORBER	2	
9	456449930	RUBBER PLATE	2	
10	001221681	BOLT 16X250 T	1	
11	032124400	CONICAL SPRING WASHER M24	2	
12	025306016	SPRING PIN 6X16	2	
13	0401450160	WASHER, FLAT M16	2	
14	020316130	NUT M16	1	
15	020416100	NUT M16, H=10	1	
18	455434950	SPINDLE	1	
19	455010030	KNOB	1	
20	939010060	SHOCK ABSORBER	1	
21	020310080	NUT M10, H=6	1	
22	020412070	NUT M12, H=7	1	
23	022411635	WING NUT M16	1	
25	954404230	CLAMP SA120-18	1	
26	011206020	BOLT 6X20 T	1	
27	030206150	WASHER, LOCK M6	1	
28	952404470	WASHER, FLAT M6	1	
29	020106050	NUT M6	1	
34	501402870	HANDLE STOPPER	1	
35	501402880	SPRING/HANDLE (1.4X18X44)	1	
36	959403460	BALL GRIP 32D-M10	1	
37	020310080	NUT M10, H=6	1	
38	456449980	RUBBER PACKING 9D-20D-5T	1	
39	953405260	PACKING 1/4 (CU)	1	
40	031110160	WASHER, FLAT M10	1	
43	464343690	HANDLE COVER	1	
44	0105050616	BOLT 6X15 T	6	
45	030206150	WASHER, LOCK M6	6	
46	952404470	WASHER, FLAT M6	6	
47	464457710	PACKING A, HANDLE COVER	1	
48	464457720	PACKING B, HANDLE COVER	1	

# MVH-306DS2 — CONTROL HANDLE ASSY. (CONTINUED)

## CONTROL HANDLE ASSY.

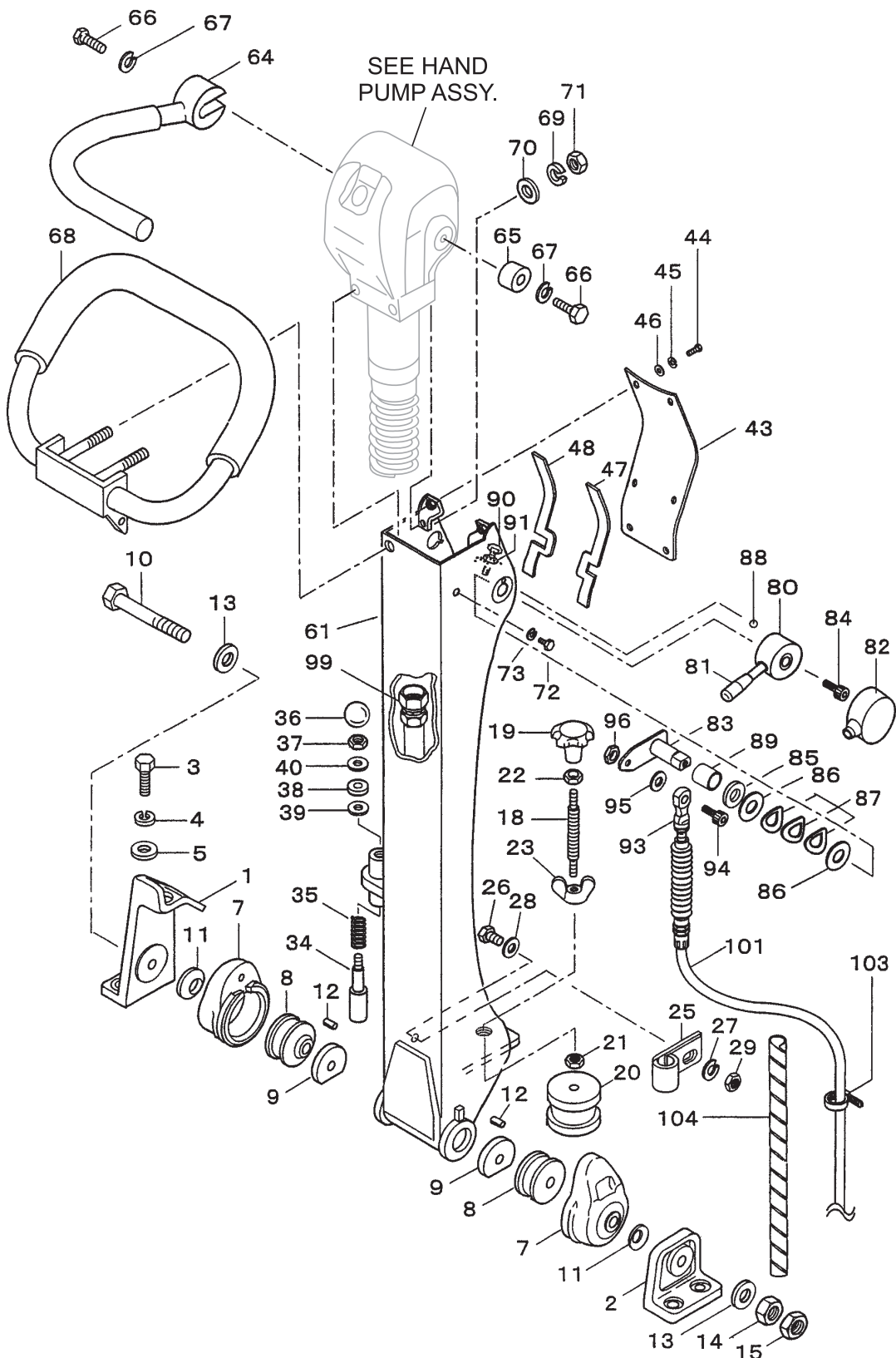

## MVH-306DS2 — CONTROL HANDLE ASSY. (CONTINUED)

### CONTROL HANDLE ASSY.

<u>NO.</u>	<u>PART NO.</u>	<u>PART NAME</u>	<u>QTY.</u>	<u>REMARKS</u>
61	464117890	HANDLE	1	
64	464216630	TRAVEL LEVER	1	
65	464457400	HANDLE BOSS	1	
66	012010030	BOLT 10X30 T	2	
67	030210250	WASHER, LOCK M10	2	
68	464216620	GRIP	1	
69	030210250	WASHER, LOCK M10	2	
70	031110160	WASHER, FLAT M10	2	
71	020310080	NUT M10	2	
72	011208025	BOLT 8X25 T	2	
73	030208200	WASHER, LOCK	2	
80	464457340	THROTTLE LEVER	1	
81	959403840	BAR GRIP I.D. 12 MM	1	
82	464457420	COVER, THROTTLE	1	
83	464457350	ARM, THROTTLE	1	
84	001520820	SOCKET HEAD BOLT 8X20 T	1	
85	031116260	WASHER, FLAT	1	
86	458460660	WASHER 16.4-35-0.6	2	
87	033910080	CONICAL SW 16.3 X 31.5 X 1.2	3	
88	464457440	STEEL BALL D6 (SUJ)	1	
89	464010010	DRY BUSHING/ LBF-1620	1	
90	001220625	BOLT 6X25 T	2	
91	020306050	NUT M6	2	
93	464010020	ROD END M5	1	
94	001520520	SOCKET HEAD BOLT 5X20 T	1	
95	031105080	WASHER, FLAT M5	1	
96	020305040	NUT M5	1	
99	954002270	OIL HOSE W/SPRING 1/4 X 920	1	
101	956100054	THROTTLE WIRE	1	
103	454010020	CLAMP TC-100	1	
104	959021815	SPIRAL TUBE 6D-330L	1	
104	959021810	SPIRAL TUBE KEP6/ L=500	1	

# MVH-306DS2 — HAND PUMP ASSY.

HAND PUMP ASSY.

84

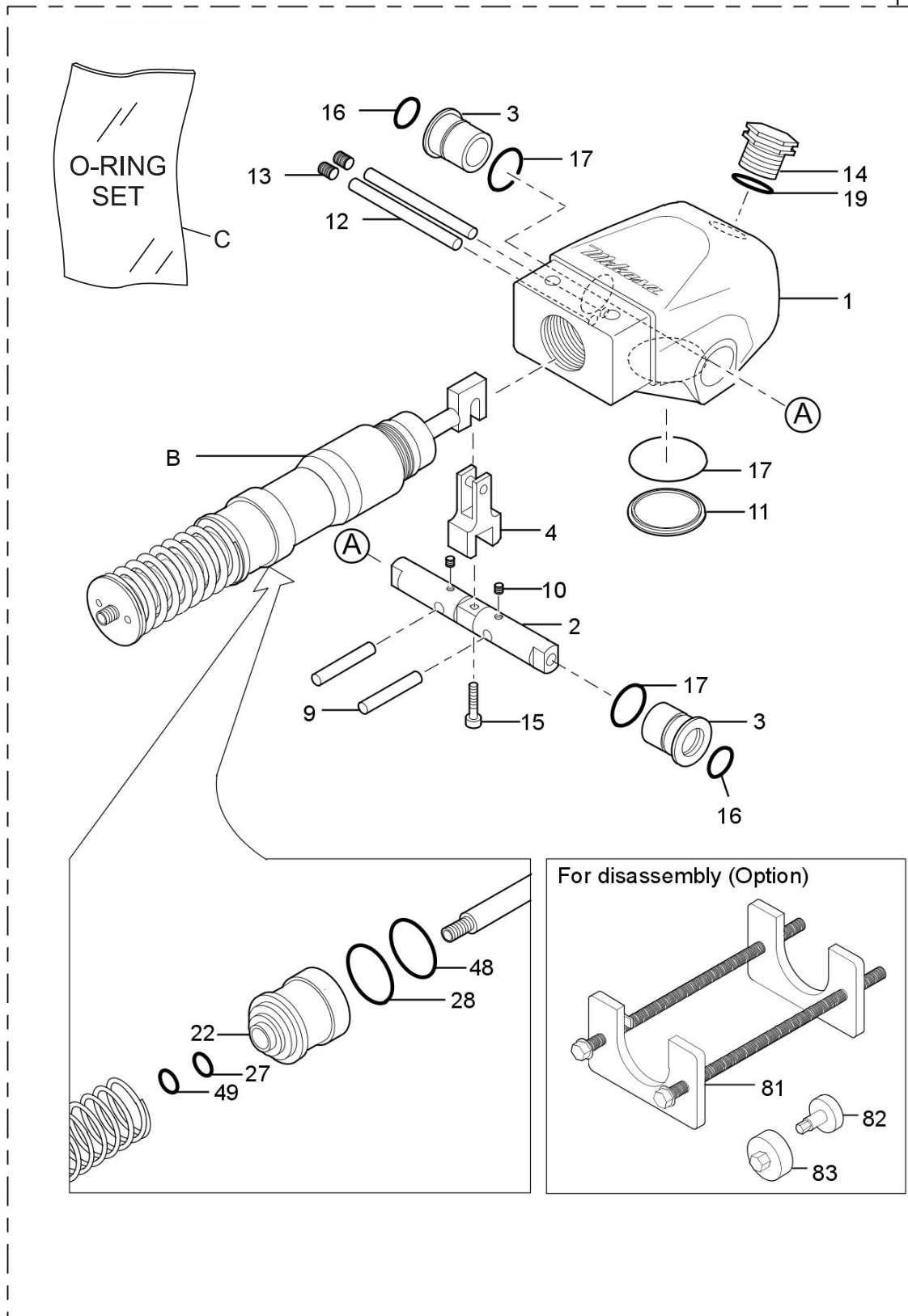

# MVH-306DS2 — HAND PUMP ASSY.

## HAND PUMP ASSY.

<u>NO.</u>	<u>PART NO.</u>	<u>PART NAME</u>	<u>QTY.</u>	<u>REMARKS</u>
B*	4649-10040	ACCUMULATOR	1	
C*	464910080	O-RING DUST,SEAL,SET .....	1 .....	INCLUDES ITEMS W/#
2*	464010040	CONTROL SHAFT	1	
3*	464010050	BUSH	2	
4*	464010060	CAM	1	
9*	464010070	STOPPER	2	
10*	099205005	SOCKET HEAD SCREW 5X5 T	2	
11*	464010080	PLUG	1	
12*	464010090	PIN,STOPPER	2	
13*	464010100	PLUG	2	
14*	458010080	BREATHER	1	
15*	001520620	SOCKET HEAD BOLT 6X20 T	1	
16#*	050200200	O-RING P-20	2	
17#*	050200220	O-RING P-22	2	
18#*	050300380	O-RING S-38	1	
19#*	050200180	O-RING P-18	1	
22*	464010110	ACCUMULATOR CASE .....	1 .....	S/N N2418 AND BELOW
22*	464010111	ACCUMULATOR CASE .....	1 .....	S/N N2419 AND ABOVE
26#*	050300400	O-RING S-40	1	
27#*	050200150	O-RING P-15	1	
28#*	050100400	O-RING G-40	1	
50*	464010120	SPRING PLUG	1	
51*	458451630	BREATHER CAP	1	
52#*	069904010	DUST SEAL SER-40 .....	1 .....	S/N N2419 AND ABOVE
53#*	069901010	DUST SEAL SER-15 .....	1 .....	S/N N2419 AND ABOVE
81*	984010030	SPRG.COMPRESSION TOOL	1	
82*	984010040	DISASSEMBLING TOOL A	1	
83*	984010050	DISASSEMBLING TOOL B	1	
84	464216721	HAND PUMP ASSY .....	1 .....	INCLUDES ITEMS W/*

# MVH-306DS2 — BATTERY ASSY. (OPTION)

BATTERY ASSY. (OPTION)

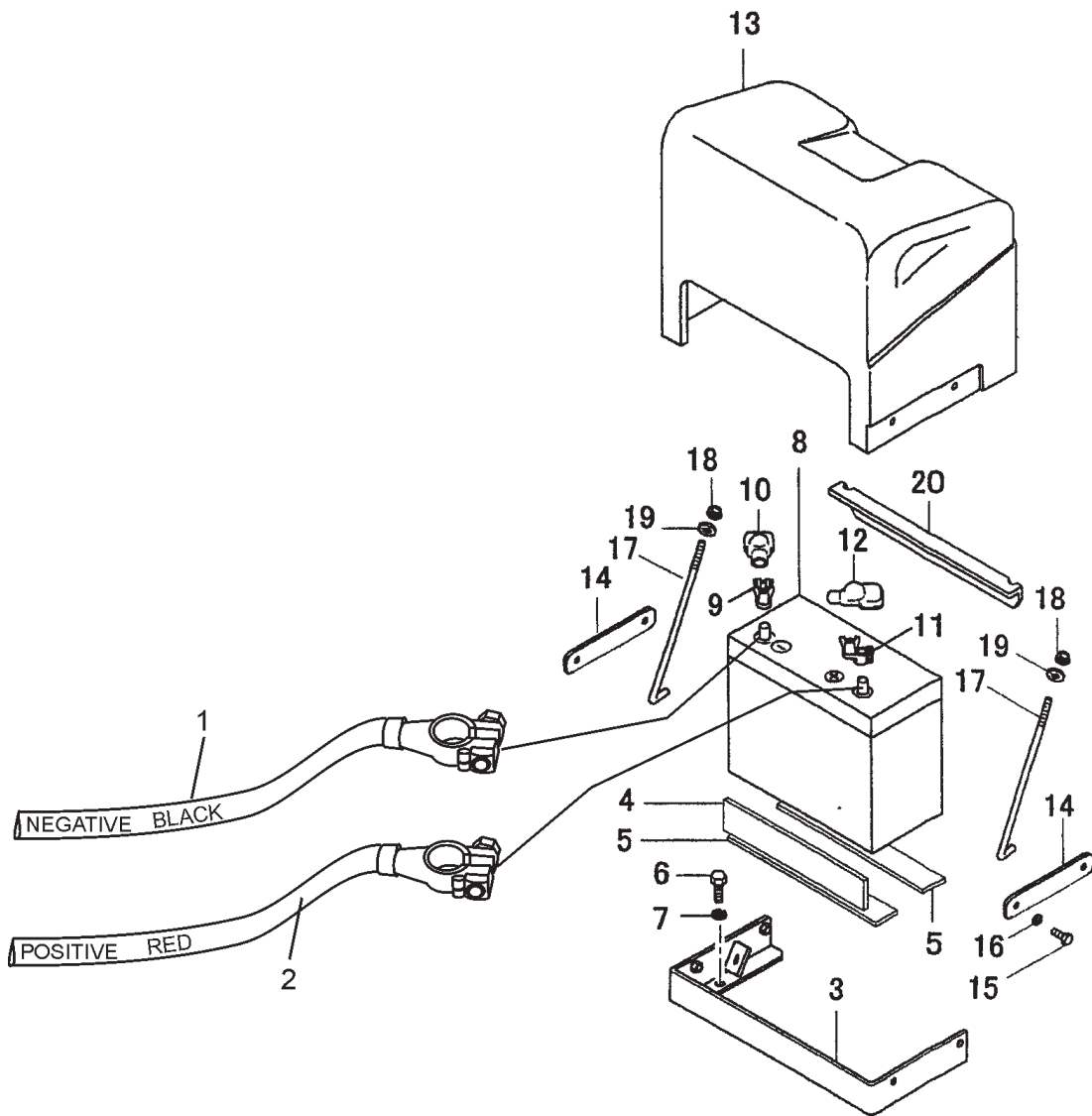

## MVH-306DS2 — BATTERY ASSY. (OPTION)

### BATTERY ASSY. (OPTION)

<u>NO.</u>	<u>PART NO.</u>	<u>PART NAME</u>	<u>QTY.</u>	<u>REMARKS</u>
1	464457460	BATTERY CORD (-) 400L	1	
2	464457470	BATTERY CORD (+) 550L	1	
3	464216660	CRADLE, BATTERY	1	
4	456447590	RUBBER PLATE (E) 28X240X5	1	
5	456447600	RUBBER PLATE 50X240X10	2	
6	014210020	SOCKET HEAD BOLT 10X20 T	2	
7	030210250	WASHER, LOCK M10	2	
8	604010240	BATTERY 46B24L	1	
9	955300490	BATTERY TERMINAL (-)	1	
10	955300470	TERMINAL COVER (-)	1	
11	955300480	BATTERY TERMINAL (+)	1	
12	955300460	TERMINAL COVER (+)	1	
13	464117860	COVER, BATTERY	1	
14	464457410	FIXED PLATE, BATTERY COVER	2	
15	001220825	BOLT 8X25 T	4	
16	030208200	WASHER, LOCK M8	4	
17	464457390	BATTERY BOLT	2	
18	022710809	NYLON NUT M8	2	
19	031108160	WASHER, FLAT M8	2	
20	464343740	HOLDER, BATTERY	1	

# MVH-306DS2 — ELECTRIC DEVICE ASSY.

ELECTRIC DEVICE ASSY.

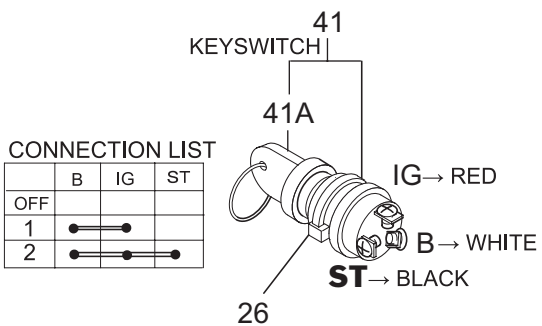
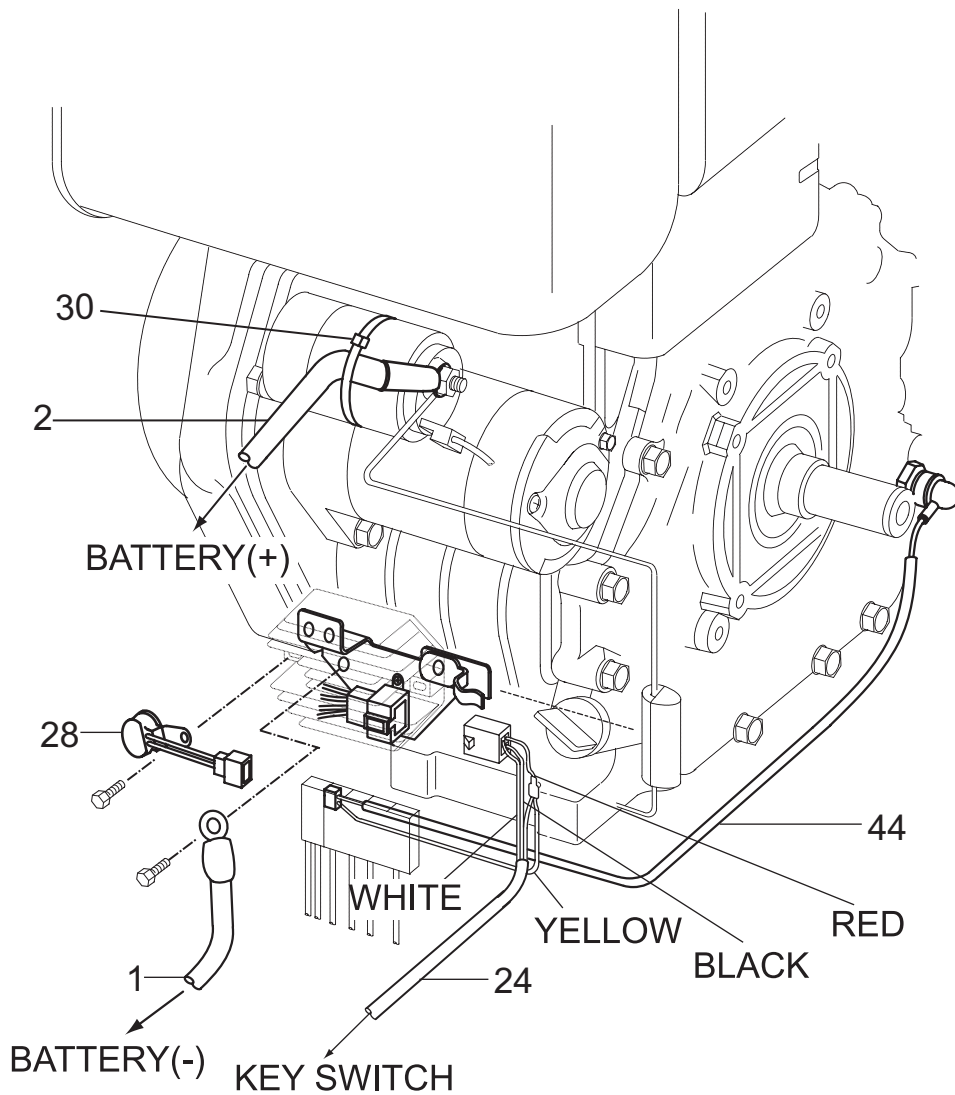

CONNECTION LIST

	B	IG	ST
OFF			
1	●	●	
2	●	●	●

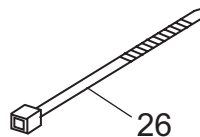

# MVH-306DS2 — ELECTRIC DEVICE ASSY.

## ELECTRIC DEVICE ASSY.

<u>NO.</u>	<u>PART NO.</u>	<u>PART NAME</u>	<u>QTY.</u>	<u>REMARKS</u>
1	464457460	BATTERY CORD (-) 400L	1	
2	464457470	BATTERY CORD (+) 550L	1	
24	464459260	WIRE CP	1	
26	454010020	CLAMPTC-100	3	
28	955300400	BUZZER (EBL)	1	
30	506010070	CLAMPTC-150	1	
41	955300680	IGNITION SWITCH ASSY. ....	1	INCLUDES ITEMS W/ #
41A#	955000010	IGNITION KEY	1	
44	105198-78570	HARNESS (C), WIRE	1	

# YANMAR L70V6 ENGINE—CYLINDER BLOCK ASSY.

## CYLINDER BLOCK ASSY.

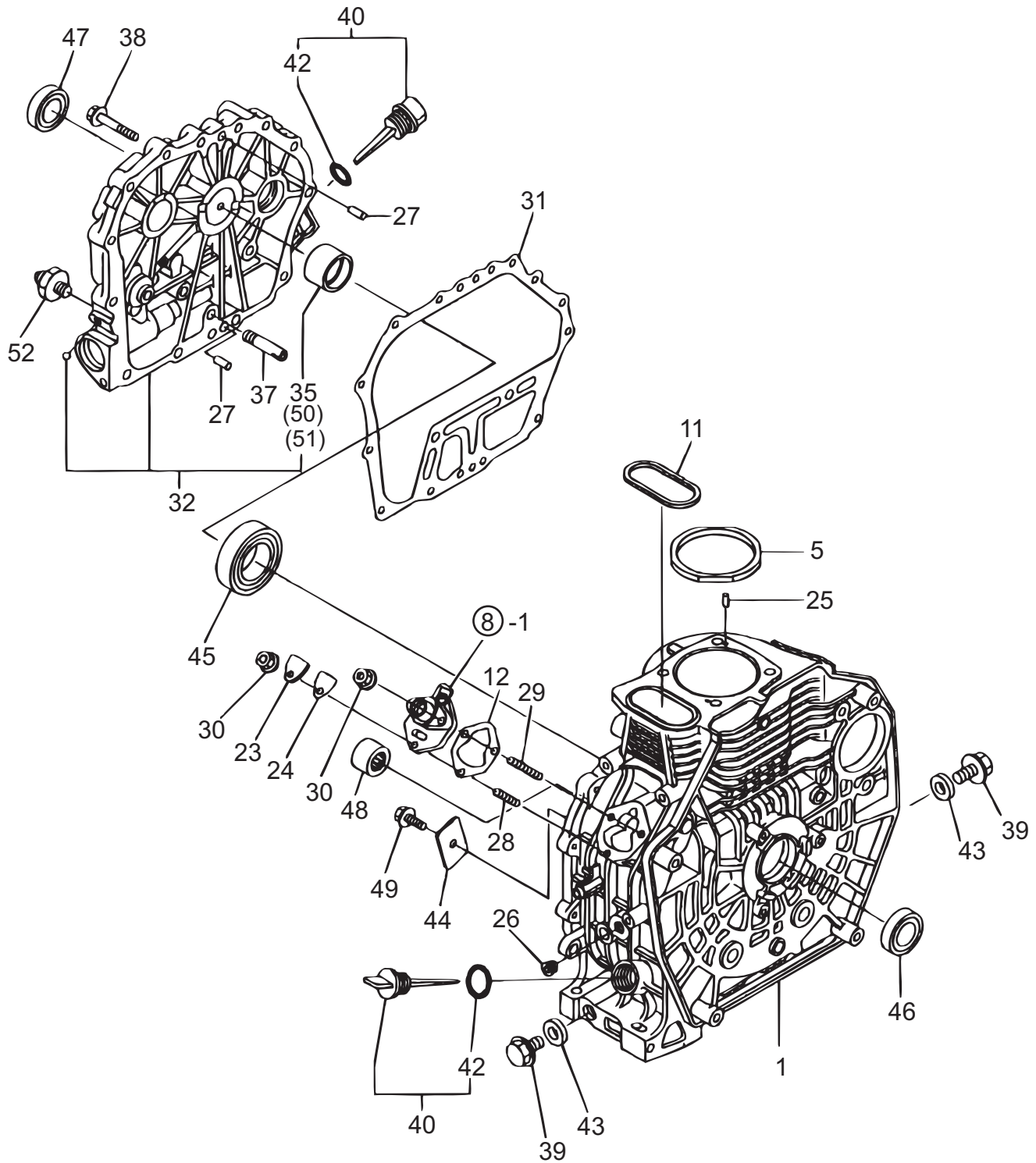

⑧-1 SEE FUEL INJECTION PUMP ASSY.

# YANMAR L70V6 ENGINE — CYLINDER BLOCK ASSY.

## CYLINDER BLOCK ASSY.

<u>NO.</u>	<u>PART NO.</u>	<u>PART NAME</u>	<u>QTY.</u>	<u>REMARKS</u>
1	11421001010	CYLINDER BLOCK ASSY.	1	
5	11439501330	CYLINDER HEAD GASKET ASSY.	1	
11	11439901380	O- RING	1	
12	11429901800	SHIM SET	1	
23	11429901830	COVER (FO PUMP)	1	
24	11425001841	GASKET	1	
25	22312040080	PIN 4X8 STRAIGHT	2	
26	23875020000	PLUG PT1/4 STEEL	1	
27	11429901600	PIN, 8X12	2	
28	26226060182	STUD M 6X18 PLATED	1	
29	26226060222	STUD M 6X22 PLATED	2	
30	26366060002	NUT M6	3	
31	11439901410	CRANKCASE GASKET	1	
32	11421001460	CRANKCASE COVER D .....	1	INCLUDES ITEMS W/ \$
35\$	11435002100	MAIN BEARING US=STD.	1	
37	11429935150	L.O. INLET PIPE	1	
38	26106080352	BOLT M 8X35 PLATED	15	
39	11429901690	PLUG M16	2	
40	11469901760	OIL GAUGE CAP, W/LUB .....	2	INCLUDES ITEMS W/ #
42#	11429901950	O- RING	2	
43	22190160002	SEAL WASHER 16S	2	
44	11429902030	RETAINER	1	
45	11435002113	BALL BEARING	1	
46	16011002220	OIL SEAL	1	
47	16011002220	OIL SEAL	1	
48	24162152116	NEEDLE BEARING	1	
49	26106080122	BOLT M 8X12 PLATED	1	
50	11435002200	MAIN BEARING US=0.25 .....	1	UNDERSIZED PART
51	11435002210	MAIN BEARING US=0.50 .....	1	UNDERSIZED PART
52	12125239450	OIL PRESSURE SENDER	1	

# YANMAR L70V6 ENGINE—CYLINDER HEAD ASSY.

CYLINDER HEAD ASSY.

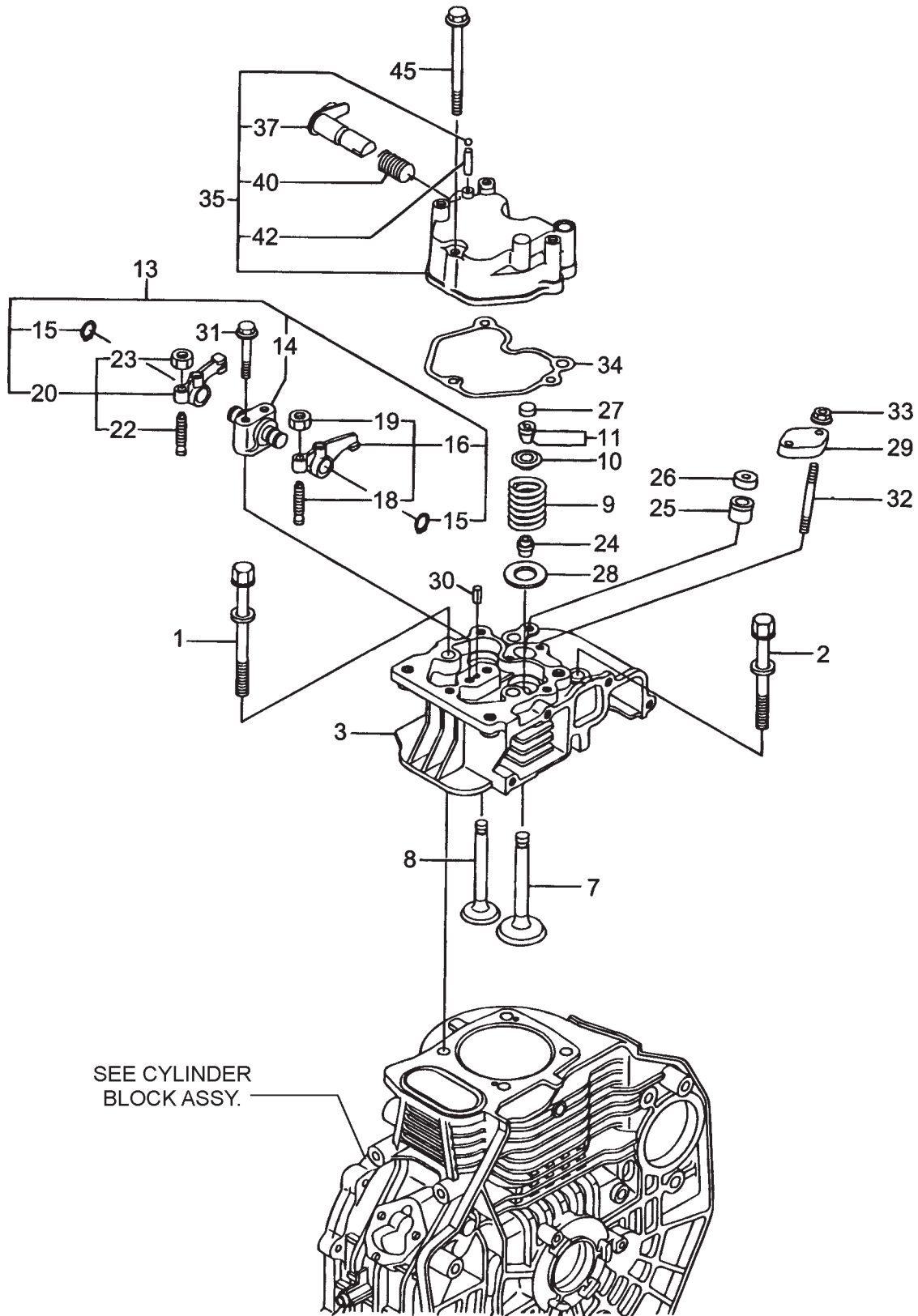

# YANMAR L70V6 ENGINE — CYLINDER HEAD ASSY.

## CYLINDER HEAD ASSY.

<u>NO.</u>	<u>PART NO.</u>	<u>PART NAME</u>	<u>QTY.</u>	<u>REMARKS</u>
1	11421001200	CYLINDER HEAD A BOLT	2	
2	11421001210	CYLINDER HEAD B BOLT	2	
3	11421011020	CYLINDER HEAD ASSY.	1	
7	11421011100	INTAKE VALVE	1	
8	11421011110	EXHAUST VALVE	1	
9	11421011120	VALVE SPRING	2	
10	11421011180	SPRING RETAINER	2	
11	11421011930	COTTER ASSY.	2	
13	11421011250	SUPPORT ASSY. ROCKER .....	1	INCLUDES ITEMS W/ #
14#	11421011260	ROCKER ARM SUPPORT	1	
15#	11421011280	C TYPE RETAINING PIN	2	
16#	11421011650	INTAKE ARM ASSY. ....	1	INCLUDES ITEMS W/ +
18#+	11429911240	ADJUSTING SCREW	1	
19#+	26856060002	LOCK NUT 6	1	
20#	11421011660	EXHAUST ARM ASSY. ....	1	INCLUDES ITEMS W/ \$
22#\$	11429911240	ADJUSTING SCREW	1	
23#\$	26856060002	LOCK NUT 6	1	
24	11435011340	VALVE STEM SEAL	2	
25	11477111461	NOZZLE GASKET	1	
26	11429511470	NOZZLE SPACER	1	
27	10501011490	VALVE CAP	2	
28	11429911600	VALVE SPRING WASHER	2	
29	11421011900	NOZZLE RETAINER	1	
30	22351040008	SPRING PIN 4X8	1	
31	26106060402	BOLT M6X40 PLATED	2	
32	26226060552	STUD M 6X55	2	
33	26366060002	NUT M6	2	
34	11421011310	BONNET GASKET	1	
35	11421011950	BONNET HEAD ASSY. ....	1	INCLUDES ITEMS W/ *
37*	11421003590	DECOMP SHAFT ASSY.	1	
40*	11429903640	DECOMP SPRING	1	
42*	22312030160	PARALLEL PIN 3X16	1	
45	26106060552	BOLT M 6X55 PLATED	1	

# YANMAR L70V6 ENGINE— AIR CLEANER ASSY.

## AIR CLEANER

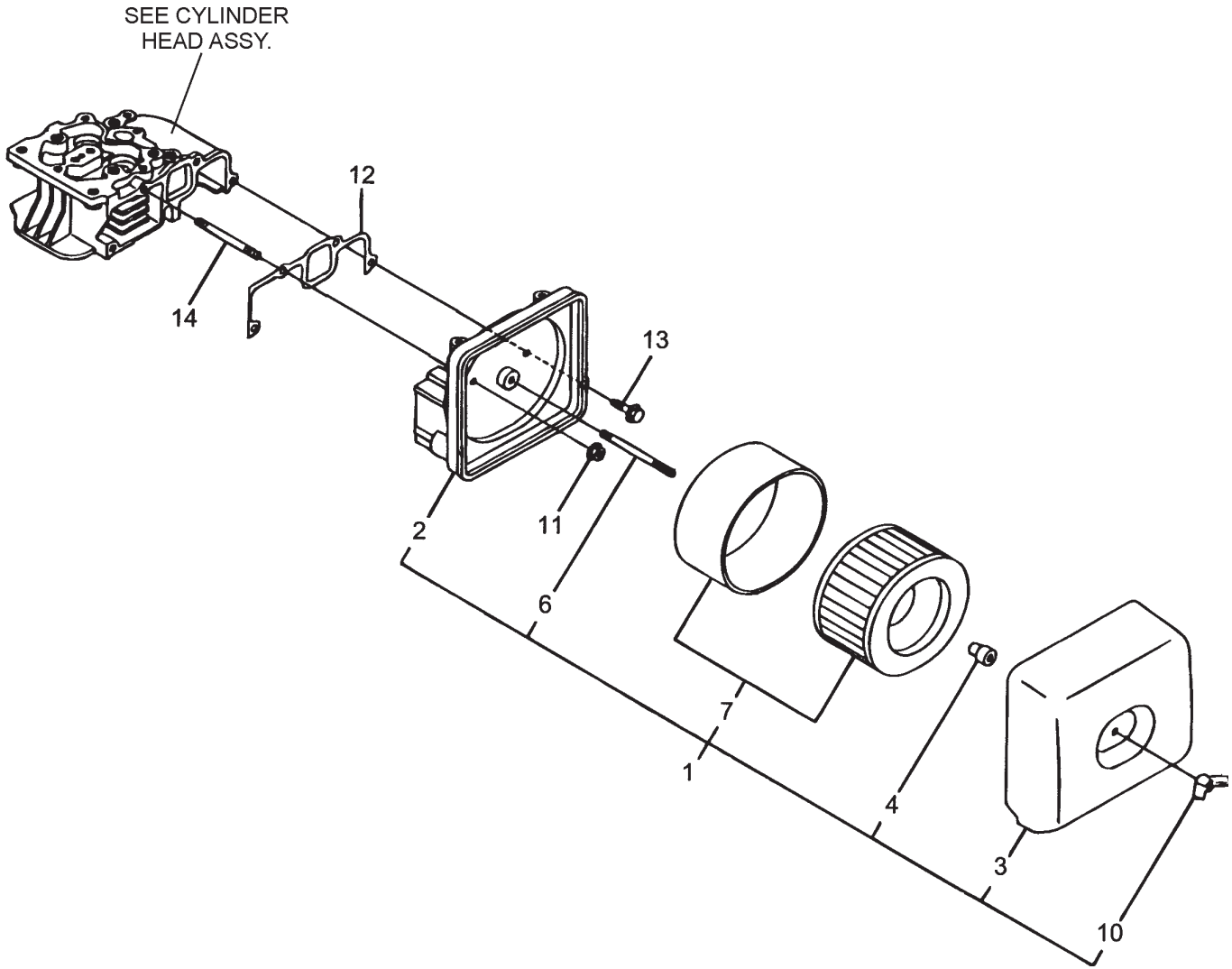

# YANMAR L70V6 ENGINE— AIR CLEANER ASSY.

## AIR CLEANER ASSY.

<u>NO.</u>	<u>PART NO.</u>	<u>PART NAME</u>	<u>QTY.</u>	<u>REMARKS</u>
1	11421012510	AIR CLEANER ASSY.....	1	INCLUDES ITEMS W/*
2*	11421012020	AIR CLEANER BODY	1	
3*	11421012520	AIR CLEANER COVER	1	
4*	11421012560	WING NUT	1	
6*	11421012580	STUD BOLT	1	
7*	11421012590	ELEMENT ASSY.	1	
10*	11421012600	KNOCKING KNOB	1	
11	11429912300	U- NUT	3	
12	11421012210	AIR CLEANER GASKET	1	
13	26106060202	BOLT M 6X20 PLATED	1	
14	26226060302	STUD M 6X30	3	

# YANMAR L70V6 ENGINE— MUFFLER ASSY.

MUFFLER ASSY.

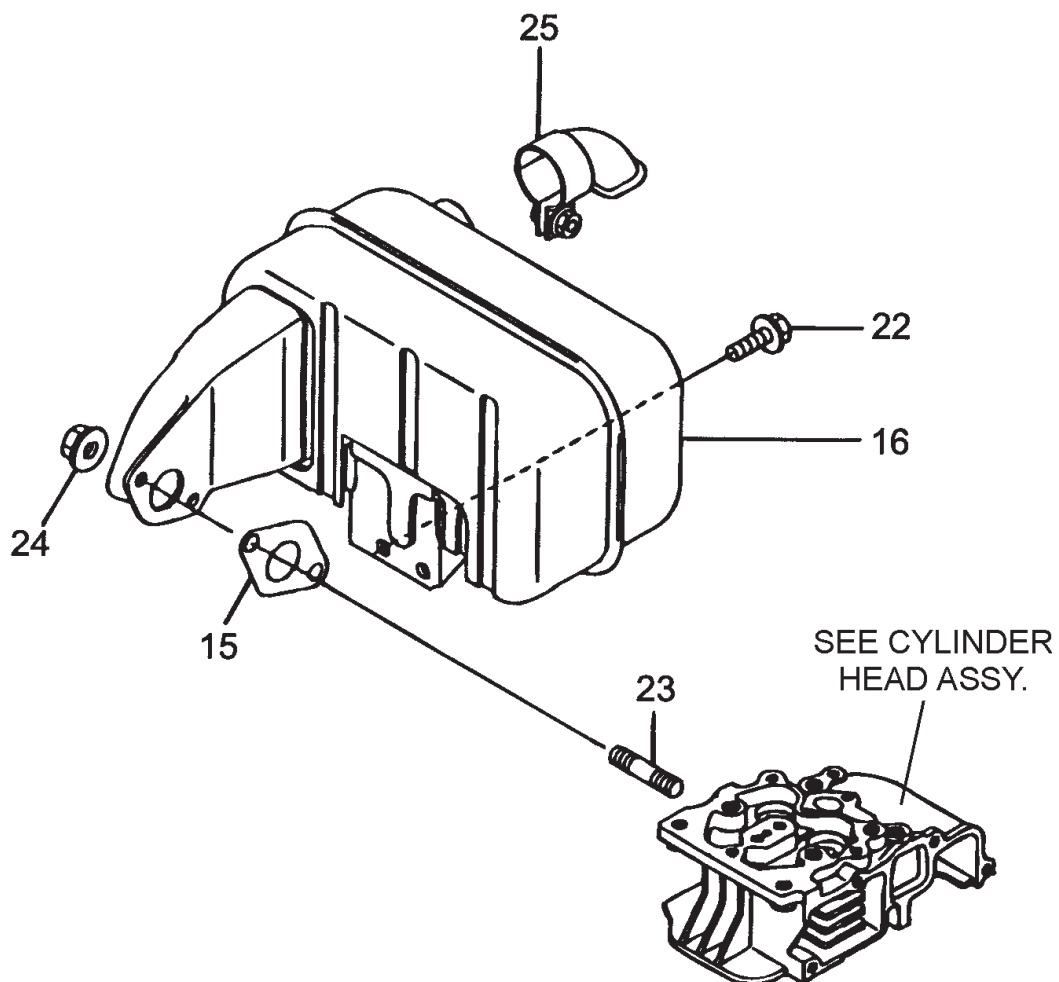

## YANMAR L70V6 ENGINE— MUFFLER ASSY.

MUFFLER ASSY.

<u>NO.</u>	<u>PART NO.</u>	<u>PART NAME</u>	<u>QTY.</u>	<u>REMARKS</u>
15	11429913200	MUFFLER GASKET	1	
16	11439913520	MUFFLER ASSY.	1	
22	26106060142	BOLT M 6X14 PLATED	2	
23	26216080182	STUD M 8X18 PLATED	2	
24	26366080002	NUT M8	2	
25	11429913800	EXHAUST DEFECTOR	1	

# YANMAR L70V6 ENGINE—CRANKSHAFT AND CAMSHAFT ASSY.

CRANKSHAFT AND CAMSHAFT ASSY.

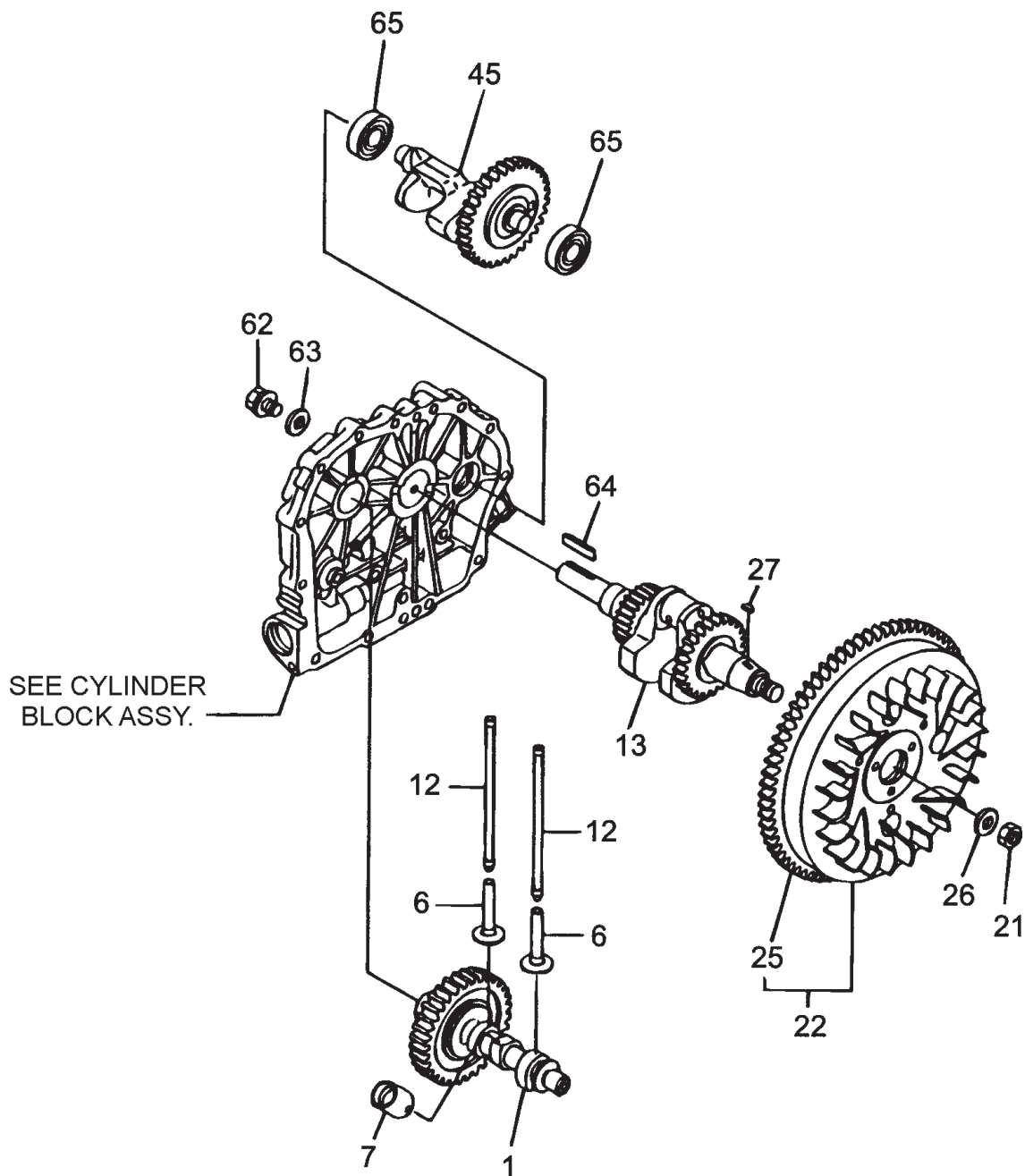

# YANMAR L70V6 ENGINE— CRANKSHAFT AND CAMSHAFT ASSY.

## CRANKSHAFT AND CAMSHAFT ASSY.

<u>NO.</u>	<u>PART NO.</u>	<u>PART NAME</u>	<u>QTY.</u>	<u>REMARKS</u>
1	71421014580	CAMSHAFT ASSY.	1	
6	11421014200	TAPPET	2	
7	11421014300	ROLLER TAPPET ASSY.	1	
12	11421014400	PUSH ROD ASSY.	2	
13	71421021740	CRANKSHAFT (D) ASSY.	1	
21	11428821220	NUT	1	
22	11439921590	FLYWHEEL (DE) ASSY. ....	1	INCLUDES ITEM W/*
25*	11436221600	RING GEAR	1	
26	11429921550	FLYWHEEL WASHER	1	
27	22512040120	KEY 4X12	1	
45	71421028510	BALANCER SHAFT ASSY.	1	
62	26106080202	BOLT M 8X20 PLATED	1	
63	16031014550	WASHER	1	
64	22512070360	KEY 7X36 RR	1	
65	24101062030	BEARING	2	

**YANMAR L70V6 ENGINE— PISTON ASSY.**

PISTON ASSY.

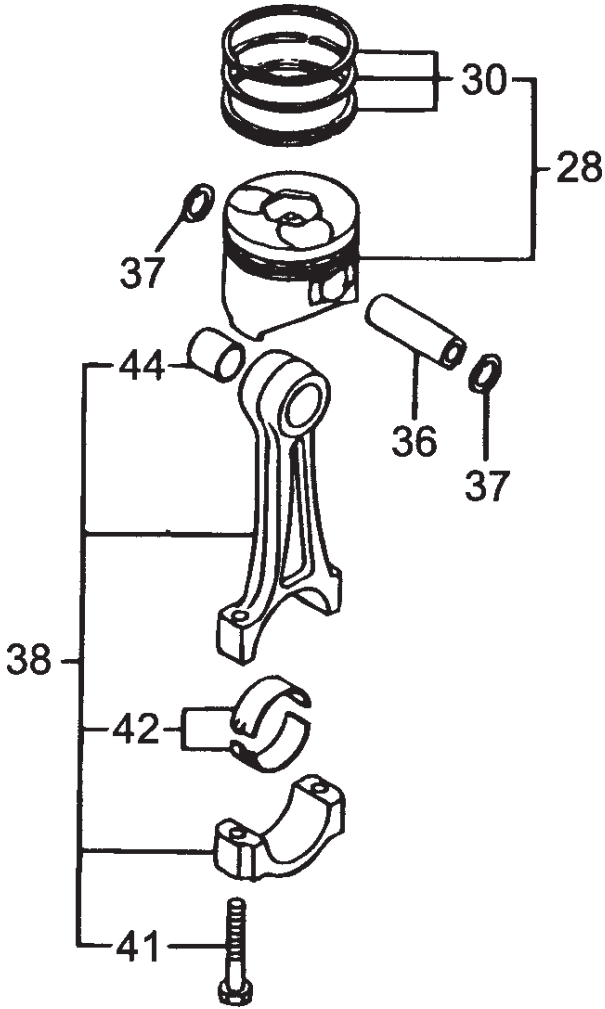

# YANMAR L70V6 ENGINE— PISTON ASSY.

## PISTON ASSY.

<u>NO.</u>	<u>PART NO.</u>	<u>PART NAME</u>	<u>QTY.</u>	<u>REMARKS</u>
28	71421022720	PISTON W/ RINGS STD .....	1 .....	INCLUDES ITEMS W/#
28	71421022620	PISTON W/RINGS OS=0.25 .....	1 .....	INCLUDES ITEMS W/\$
28	71421022580	PISTON W/RINGS OS=0.50 .....	1 .....	INCLUDES ITEMS W/%
30#	71487022502	PISTON RINGS SET=STD.	1	
30\$	71487022542	PISTON RING SET 0.S.=0.25	1	
30%	71487022552	PISTON RING SET 0.2=0.50	1	
36	11439922300	PISTON PIN	1	
37	22252000210	CIRCLIP 21	2	
38	71421023700	CONNECTING ROD ASSY. ....	1 .....	INCLUDES ITEMS W/*
41*	11820023200	ROD BOLT	2	
42*	11421023600	CRANK PIN BEARING STD.	1	
42	11421023610	CRANK BEARING PIN U.S.=0.25 .....	1 .....	UNDERSIZED PART
42	11421023620	CRANK BEARING PIN U.S.=0.50 .....	1 .....	UNDERSIZED PART
44*	11438023100	PISTON PIN BUSH	1	

# YANMAR L70V6 ENGINE— LUB. OIL PUMP AND GOVERNOR ASSY.

LUB. OIL PUMP & GOVERNOR ASSY.

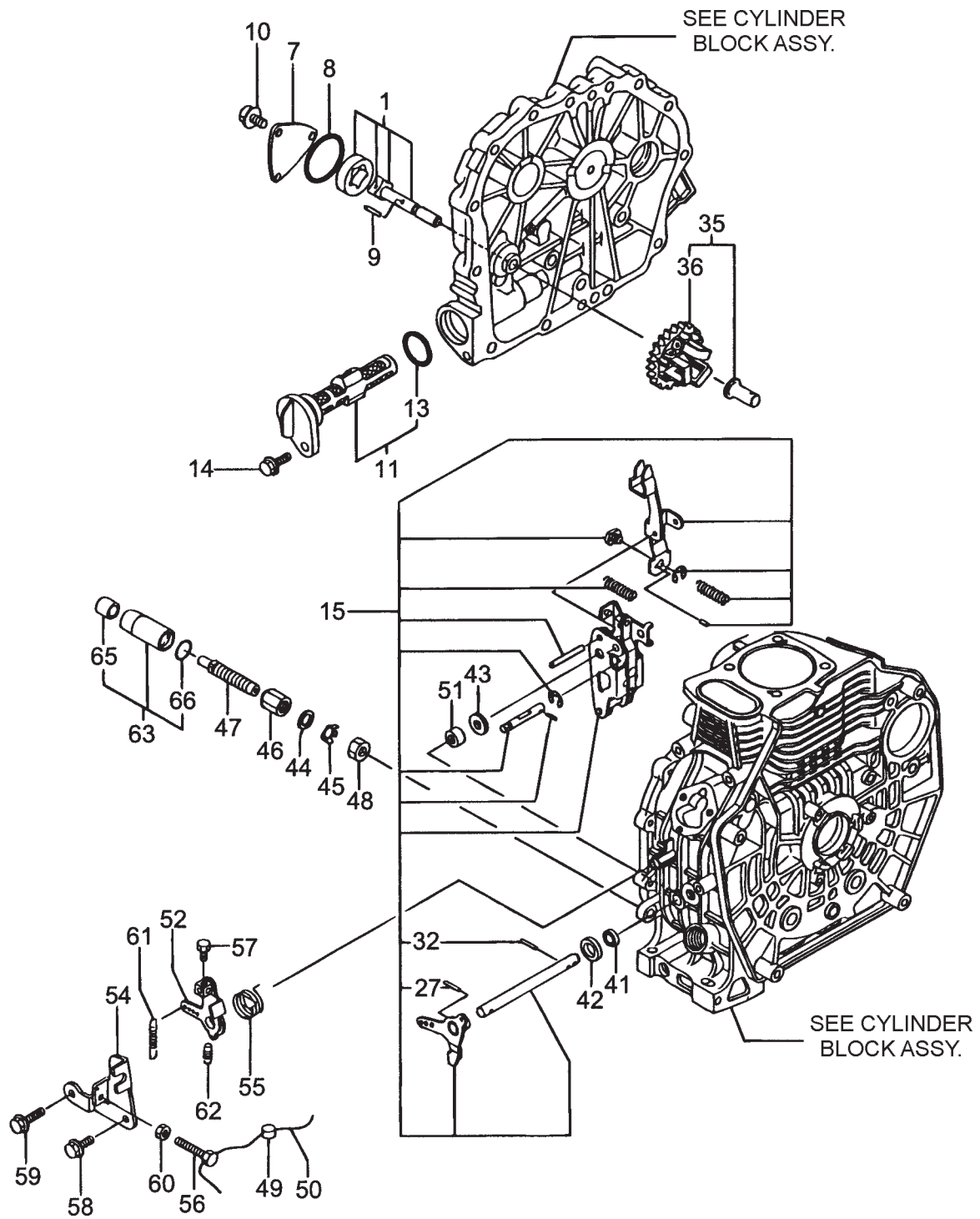

# YANMAR L70V6 ENGINE— LUB. OIL PUMP AND GOVERNOR ASSY.

## LUB. OIL PUMP AND GOVERNOR ASSY.

<u>NO.</u>	<u>PART NO.</u>	<u>PART NAME</u>	<u>QTY.</u>	<u>REMARKS</u>
1	11425032010	LUB. OIL PUMP ASSY.	1	
7	11429932070	LUB. OIL PUMP COVER	1	
8	11429932570	O- RING COVER	1	
9	22312030160	PARALLEL PIN 3X16	1	
10	26106060122	BOLT M 6X12 PLATED	3	
11	11429935110	LUBE OIL FILTER COMPLETE .....	1	INCLUDES ITEMS W/*
13*	24341000224	O- RING 1A S- 22.4	1	
14	26106060162	BOLT M 6X16 PLATED	1	
15	11421061500	LEVER ASSY.....	1	INCLUDES ITEMS W/#
27#	22322030200	TAPER PIN 3X20	1	
32#	22322030200	TAPER PIN 3X20	1	
35	71421061700	GOVERNOR ASSY. ....	1	INCLUDES ITEMS W/+
36+	11421061290	GOVERNOR WEIGHT ASSY.	1	
41	11429961600	OIL SEAL	1	
42	11477061610	THRUST WASHER	1	
43	11429961190	GOVERNOR WASHER	1	
44	11477161810	PLAIN WASHER 14	1	
45	11477161830	PLATE	1	
46	11429561940	NUT	1	
47	11477166600	FUEL LIMITER ASSY.	1	
48	11477166690	NUT M14	1	
49	13521061090	LEAD	1	
50	22451060000	WIRE 0.6	1	
51	11477061520	NEEDLE BEARING	2	
52	11425266051	REGULATOR HANDLE	1	
54	18336066110	REGULATOR BRACKET	1	
55	11429966250	RETURN SPRING	1	
56	11429966440	ADJUSTING BOLT	1	
57	10522566990	SCREW	1	
58	26106060142	BOLT M 6X14 PLATED	1	
59	26106060202	BOLT M 6X20 PLATED	1	
60	26757060002	LOCK NUT M6 PLATED	1	
61	11421066010	REGULATOR SPRING	1	
62	11429966200	RETURN SPRING	1	
63	11477161890	PROTECTOR COMPLETE .....	1	INCLUDES ITEMS W/%
65%	11477161960	SPACER	1	
66%	24311000180	O- RING 1A P- 18.0	1	

# YANMAR L70V6 ENGINE— COOLING AND STARTING DEVICE ASSY.

COOLING AND STARTING DEVICE ASSY.

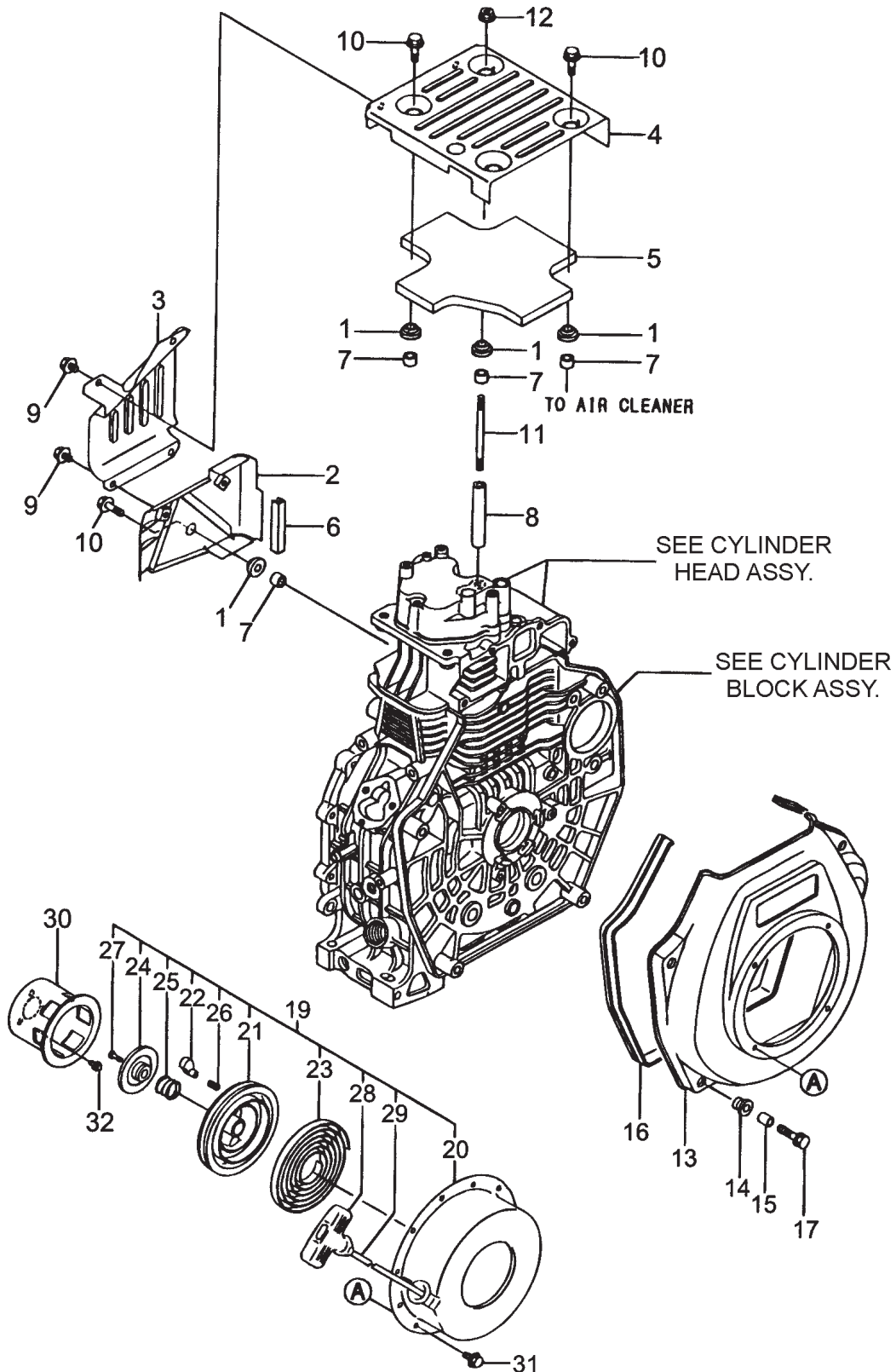

# YANMAR L70V6 ENGINE— COOLING AND STARTING DEVICE ASSY.

## COOLING AND STARTING DEVICE ASSY.

<u>NO.</u>	<u>PART NO.</u>	<u>PART NAME</u>	<u>QTY.</u>	<u>REMARKS</u>
1	11429945220	TANK GROMMET	5	
2	11421045260	SIDE COVER B (13)	1	
3	11421045270	SIDE COVER A (13)	1	
4	11421045300	TOP COVER, BLACK (13)	1	
5	11421045310	DAMPER	1	
6	11439945320	SEAL RUBBER	1	
7	11439945340	CYLINDER COLLAR COVER	5	
8	11421045350	TOP COVER SPACER	1	
9	26106060082	BOLT M 6X 8 PLATED	4	
10	26106060202	BOLT M 6X 20 PLATED	4	
11	26226060852	BOLT STUD 6X85	1	
12	26366060002	NUT M 6	1	
13	11421045100	FAN CASE (SILVER) (17)	1	
14	11429945300	CUSHION RUBBER	4	
15	11429945310	FAN CASE COLLAR	4	
16	11429945330	FAN CASE SEAL	1	
17	11429945350	FAN CASE BOLT	4	
19	11439976250	RECOIL STARTER (D) ASSY. ....	1	INCLUDES ITEMS W/*
20*	11439976510	STARTER CASE	1	
21*	11439976520	RECOIL REEL	1	
22*	11439976530	RATCHET	1	
23*	11439976540	SPIRAL SPRING	1	
24*	11439976550	RATCHET COVER	1	
25*	11439976560	SPRING	1	
26*	11439976570	RETURN SPRING	1	
27*	11439976580	SCREW	1	
28*	11439976620	STARTER KNOB	1	
29*	11439976630	STARTER ROPE	1	
30	11439976590	STARTER PULLEY	1	
31	26106060082	BOLT M 6X 8 PLATED	4	
32	26106060122	BOLT M 6X 12 PLATED	3	

# YANMAR L70V6 ENGINE— FUEL INJECTION PUMP ASSY.

## FUEL INJECTION PUMP ASSY.

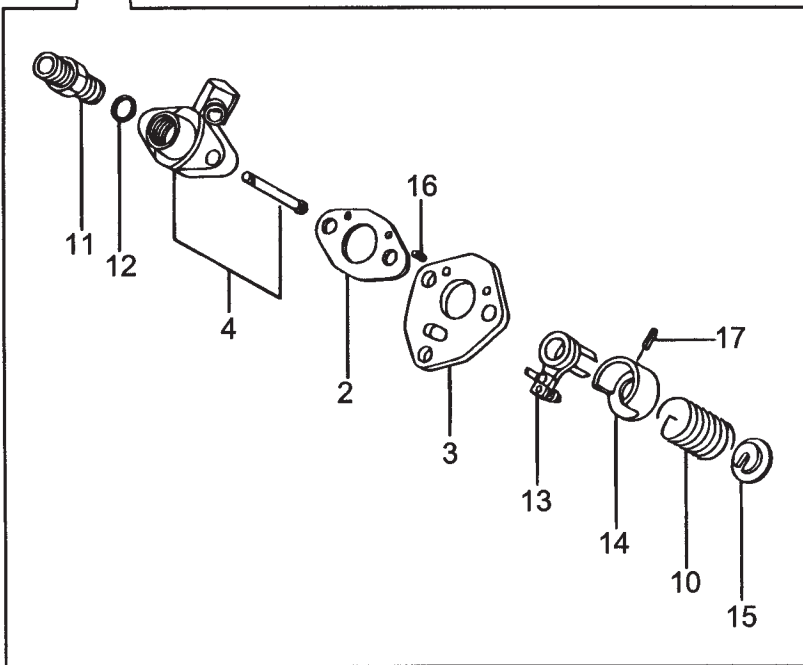
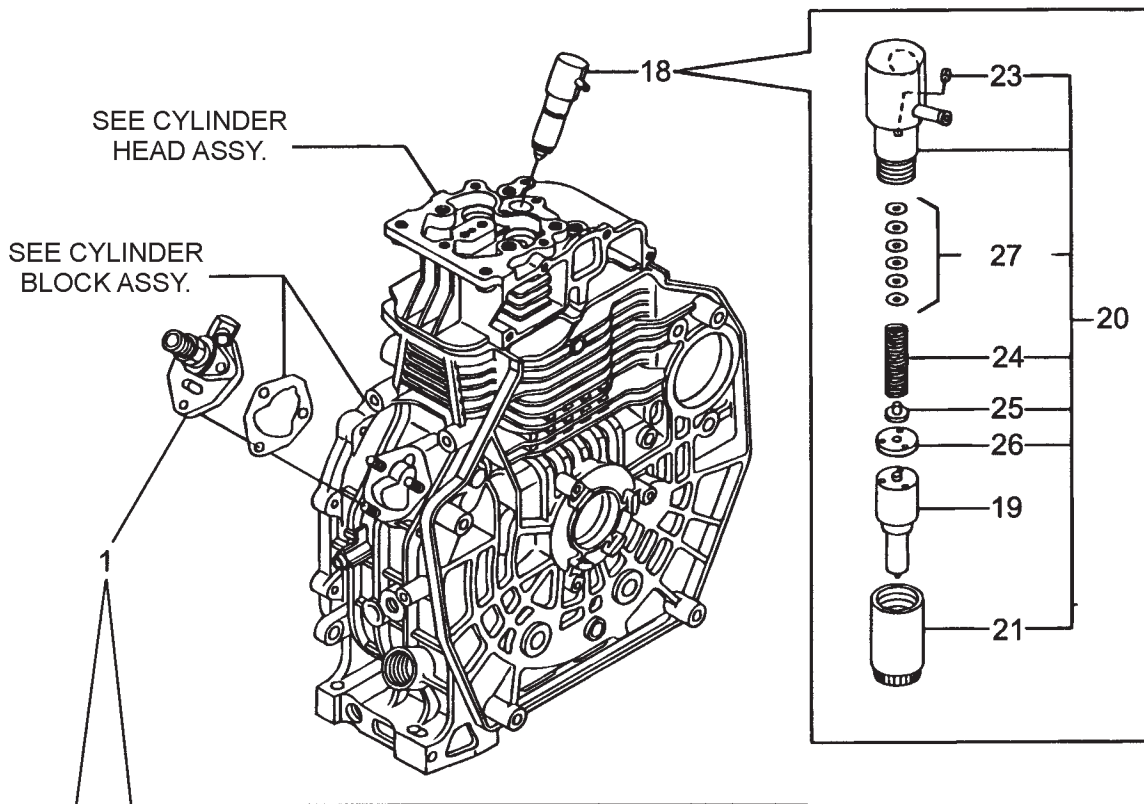

- T=1 00
- T=1 05
- T=1 10
- T=1 15
- T=1 20
- T=1 25
- T=1 30
- T=1 35
- T=1 40
- T=1 45
- T=1,50
- T=1 55
- T=1 60
- T=1 65
- T=1 70
- T=1 75
- T=1 80
- T=1 85
- T=1 90
- T=1 95
- T=2 00

SHIMS, USE AS  
REQUIRED FOR  
ITEM 27.

# YANMAR L70V6 ENGINE — FUEL INJECTION PUMP ASSY.

## FUEL INJECTION PUMP ASSY.

<u>NO.</u>	<u>PART NO.</u>	<u>PART NAME</u>	<u>QTY.</u>	<u>REMARKS</u>
1	71421051100	FUEL INJECTION PUMP ASSY. ....	1	INCLUDES ITEMS W/*
2*	10554651020	GASKET	1	
3*	11425051080	PLATE	1	
4*	11421051200	FUEL INJECTION PUMP BODY	1	
10*	11425051160	SPRING	1	
11*	11421051300	DELIVERY VALVE ASSY.	1	
12*	12455051350	DELIVERY GASKET	1	
13*	11425051600	CONTROL LEVER ASSY.	1	
14*	11425051640	SPRING SEAT A	1	
15*	11425051650	SPRING SEAT B	1	
16*	22351020006	SPRING PIN 2X 6	2	
17*	22351030008	SPRING PIN 3X 8	1	
18	71421053100	FUEL INJECTOR .....	1	INCLUDES ITEMS W/\$
19\$	11421053000	NOZZLE ASSY.	1	
20\$	11421053100	NOZZLE HOLDER ASSY. ....	1	INCLUDES ITEMS W/#
21\$#	11421053080	NOZZLE NUT	1	
23\$#	11421053330	PIN	1	
24\$#	11421053120	NOZZLE SPRING	1	
25\$#	11421053130	SPRING SEAT	1	
26\$#	11421053140	VALVE SPACER ASSY.	1	
27\$#	11421053410	SHIM (T=1.00)	1	
27	11421053420	SHIM (T=1.05)	1	
27	11421053430	SHIM (T=1.10)	1	
27	11421053440	SHIM (T=1.15)	1	
27	11421053450	SHIM (T=1.20)	1	
27	11421053460	SHIM (T=1.25)	1	
27	11421053470	SHIM (T=1.30)	1	
27	11421053480	SHIM (T=1.35)	1	
27	11421053490	SHIM (T=1.40)	1	
27	11421053500	SHIM (T=1.45)	1	
27	11421053510	SHIM (T=1.50)	1	
27	11421053520	SHIM (T=1.55)	1	
27	11421053530	SHIM (T=1.60)	1	
27	11421053540	SHIM (T=1.65)	1	
27	11421053550	SHIM (T=1.70)	1	
27	11421053560	SHIM (T=1.75)	1	
27	11421053570	SHIM (T=1.80)	1	
27	11421053580	SHIM (T=1.85)	1	
27	11421053590	SHIM (T=1.90)	1	
27	11421053600	SHIM (T=1.95)	1	
27	11421053610	SHIM (T=2.00)	1	



# YANMAR L70V6 ENGINE — FUEL TANK AND FUEL LINE ASSY.

## FUEL TANK AND FUEL LINE ASSY.

<u>NO.</u>	<u>PART NO.</u>	<u>PART NAME</u>	<u>QTY.</u>	<u>REMARKS</u>
1	71421055700	FUEL TANK, BLACK .....	1	INCLUDES ITEMS W/*
3*	23414080000	PACKING 8	1	
4*	10530055080	DRAIN PLUG	1	
5*	11428855041	FUEL TANK CAP ASSY. ....	1	INCLUDES ITEMS W/+
7*+	11428855081	CAP VALVE	1	
8*	11429955100	FILTER, FUEL	1	
9*	11425055201	FUEL TANK DAMPER	4	
10	11425055121	FUEL FILTER .....	1	INCLUDES ITEMS W/#
11#	11425055130	GASKET	1	
12	11421055210	FUEL TANK STAY A	1	
13	11421055230	FUEL TANK STAY B	1	
14	11425055301	FUEL COCK ASSY. ....	1	INCLUDES ITEMS W/ \$
15\$	24341000150	O- RING 1A S- 15.0	1	
16	11421055810	LIFTING BOLT	1	
17	22117080000	WASHER 8	1	
18	26106080452	BOLT M 8X 45 PLATED	1	
19	26366060002	NUT M 6	2	
20	26106060162	BOLT M 6X 16 PLATED	2	
21	11421059200	RETURN PIPE ASSY. ....	1	INCLUDES ITEMS W/%
22%	12472259050	CLAMP 9	2	
23%	11465059060	FUEL RETURN PIPE	1	
24%	11465259310	PROTECT TUBE	1	
25%	12175059890	RETAINER	1	
26	11477059030	FUEL OIL PIPE ASSY. ....	1	INCLUDES ITEMS W/>
27>	11427059010	HOSE CLIP	2	
28>	11426859061	FUEL OIL PIPE	1	
29	11421059800	FUEL INJECTION PIPE	1	
35	11421059850	INJECTION PIPE SUPPORT	1	

# YANMAR L70V6 ENGINE— STARTING MOTOR AND DYNAMO ASSY.

## STARTING MOTOR AND DYNAMO ASSY.

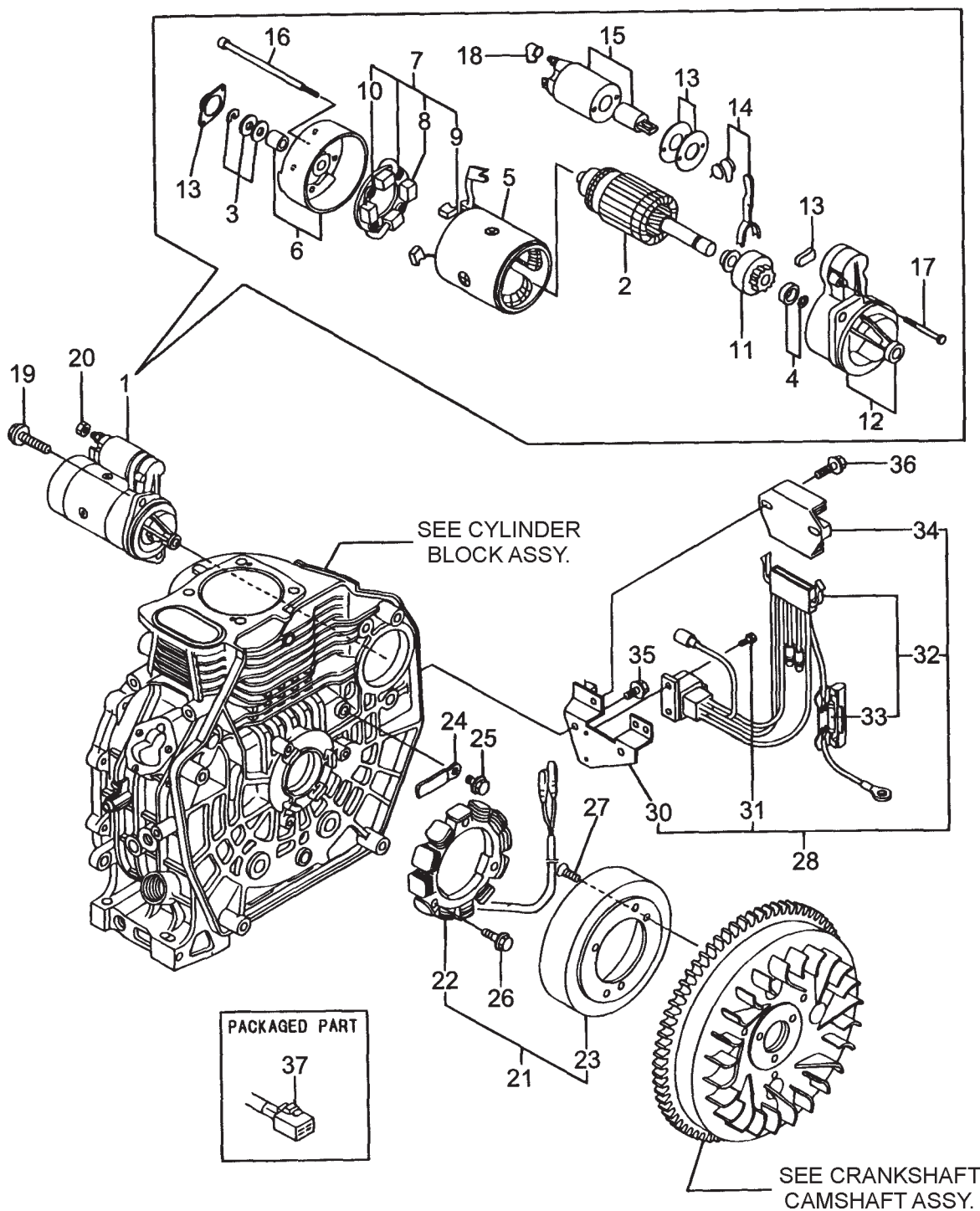

# YANMAR L70V6 ENGINE— STARTING MOTOR AND DYNAMO ASSY.

## STARTING MOTOR & DYNAMO ASSY.

<u>NO.</u>	<u>PART NO.</u>	<u>PART NAME</u>	<u>QTY.</u>	<u>REMARKS</u>
1	71436277011	STARTER (S114-414A .....	1	INCLUDES ITEMS W/*
2*	11438177110	ARMATURE	1	
3*	X2114811000	THRUST WASHER KIT	1	
4*	X2114715500	PINION STOPPER SET	1	
5*	11438177130	FIELD COIL ASSY.	1	
6*	11438177140	REAR COVER	1	
7*	11437177160	BRUSH HOLDER ASSY. ....	1	INCLUDES ITEMS W/#
8*#	11437179040	BRUSH (-)	2	
9*#	11437179050	BRUSH (+)	1	
10*#	11437179060	BRUSH SPRING	4	
11*	X211485016	PINION ASSY.	1	
12*	11438177151	GEAR HOUSING ASSY.	1	
13*	11437177170	DUST COVER KIT	1	
14*	11437177180	SHIFT LEVER KIT	1	
15*	12429877020	MAGNET SWITCH	1	
16*	12419577770	THROUGH BOLT	2	
17*	11437179070	BOLT M 6X 37	2	
18*	X2114274200	TERMINAL COVER	1	
19	26106100302	BOLT M 10X 30 PLATED	2	
20	26716080002	NUT M 8	1	
21	11439978260	DYNAMO ASSY. ....	1	INCLUDES ITEMS W/ >
22>	11439978730	STATOR ASSY.	1	
23>	11439978740	DYNAMO WHEEL	1	
24	16071078710	CORD CLAMP	1	
25	26106060122	BOLT M 6X 12 PLATED	1	
26	26106060202	BOLT M 6X 20 PLATED	3	
27	26577060142	SCREW M 6X 14	3	
28	11439977550	REG. & HARNESS ASSY. ....	1	INCLUDES ITEMS W/ +
30+	11439977400	HARNESS BRACKET	1	
31+	26023040102	SCREW M4X10	2	
32+	11439977540	WIRE HARNESS .....	1	INCLUDES ITEMS W/ %
33+%	29411200000	CARTRIDGE FUSE 20A	2	
34+	11439977710	REGULATOR	1	
35	26106060122	BOLT M 6X 12 PLATED	2	
36	26106060202	BOLT M 6X 20 PLATED	2	
37	11435177520	JOINT	1	

# YANMAR L70V6 ENGINE — TOOLS, LABELS AND GASKETS SET ASSY.

TOOLS, LABELS AND GASKET SET ASSY.

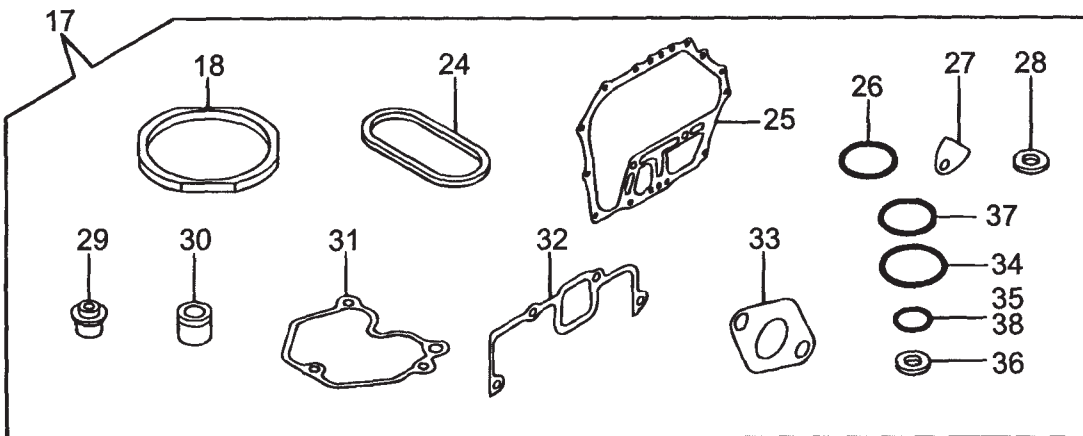
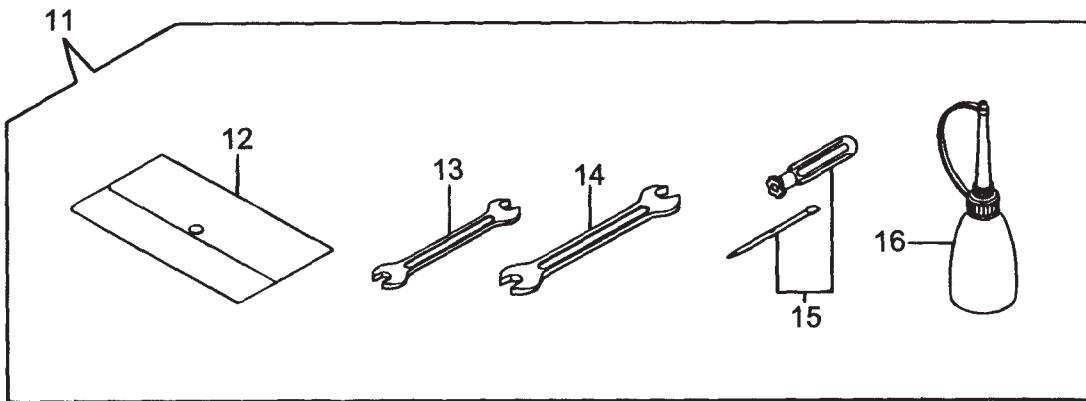
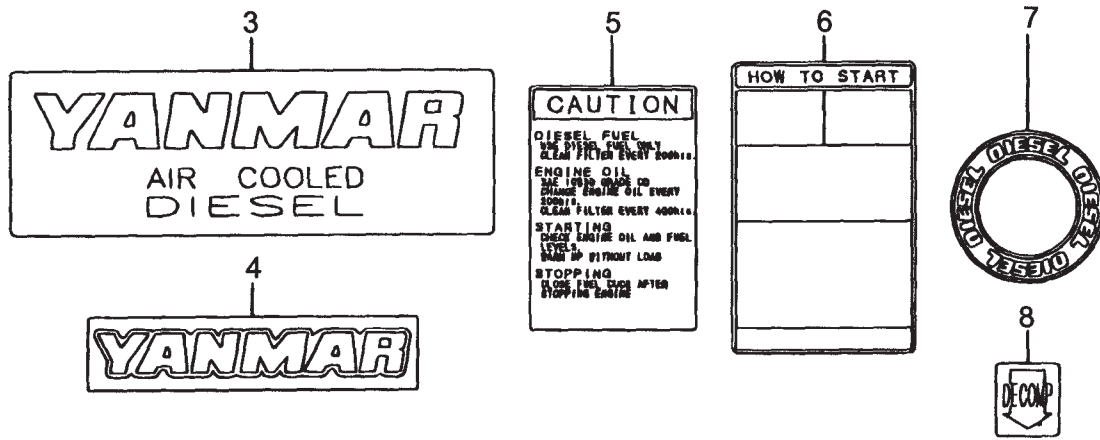

# YANMAR L70V6 ENGINE — TOOLS, LABELS AND GASKETS SET ASSY.

## TOOLS, LABELS AND GASKET SET ASSY.

<u>NO.</u>	<u>PART NO.</u>	<u>PART NAME</u>	<u>QTY.</u>	<u>REMARKS</u>
3	11429907100	AIR COOLED LABEL	1	
4	11429907110	YANMAR LABEL	1	
5	11421007120	CAUTION LABEL	1	
6	11421007130	HOW TO START- E LABEL	1	
7	11429907160	DIESEL LABEL	1	
8	11421007200	DECOMPRESSION LABEL	1	
11	11429992590	TOOL ASSY. ....	1	INCLUDES ITEMS W/*
12*	11429992600	TOOL BAG	1	
13*	11429992710	SPANNA	1	
14*	11429992720	SPANNA	1	
15*	11429992730	DRIVER	1	
16*	11429992740	FUEL FITTING	1	
17	71421092600	GASKET SET (NON- ASB).....	1	INCLUDES ITEMS W/ #
18 #	11439501330	CYLINDER HEAD GASKET ASSY.	1	
24 #	11439901380	O- RING	2	
25 #	11439901410	CRANK CASE GASKET	1	
26 #	11429901950	O- RING	2	
27 #	11425001841	GASKET	1	
28 #	22190160002	WASHER SEAL 16S	2	
29 #	11435011340	VALVE STEM SEAL	2	
30 #	11477111461	NOZZLE GASKET	1	
31 #	11421011310	BONNET GASKET	1	
32 #	11421012210	AIR CLEANER GASKET	1	
33 #	11429913200	MUFFLER GASKET	1	
34 #	11429932570	O- RING COVER	1	
35 #	24341000100	O- RING 1A S- 10.0	1	
36 #	23414080000	PACKING 8	1	
37 #	24341000224	O- RING 1A S- 22.4	1	
38 #	24341000150	O- RING 1A S-15.0	1	

# TERMS AND CONDITIONS OF SALE — PARTS

## PAYMENT TERMS

Terms of payment for parts are net 30 days.

## FREIGHT POLICY

All parts orders will be shipped collect or prepaid with the charges added to the invoice. All shipments are F.O.B. point of origin. Multiquip's responsibility ceases when a signed manifest has been obtained from the carrier, and any claim for shortage or damage must be settled between the consignee and the carrier.

## MINIMUM ORDER

The minimum charge for orders from Multiquip is \$15.00 net. Customers will be asked for instructions regarding handling of orders not meeting this requirement.

## RETURNED GOODS POLICY

Return shipments will be accepted and credit will be allowed, subject to the following provisions:

1. A Returned Material Authorization must be approved by Multiquip prior to shipment.
2. To obtain a Return Material Authorization, a list must be provided to Multiquip Parts Sales that defines item numbers, quantities, and descriptions of the items to be returned.
  - a. The parts numbers and descriptions must match the current parts price list.
  - b. The list must be typed or computer generated.
  - c. The list must state the reason(s) for the return.
  - d. The list must reference the sales order(s) or invoice(s) under which the items were originally purchased.
  - e. The list must include the name and phone number of the person requesting the RMA.
3. A copy of the Return Material Authorization must accompany the return shipment.
4. Freight is at the sender's expense. All parts must be returned freight prepaid to Multiquip's designated receiving point.

5. Parts must be in new and resalable condition, in the original Multiquip package (if any), and with Multiquip part numbers clearly marked.
6. The following items are not returnable:
  - a. Obsolete parts. (If an item is in the price book and shows as being replaced by another item, it is obsolete.)
  - b. Any parts with a limited shelf life (such as gaskets, seals, "O" rings, and other rubber parts) that were purchased more than six months prior to the return date.
  - c. Any line item with an extended dealer net price of less than \$5.00.
  - d. Special order items.
  - e. Electrical components.
  - f. Paint, chemicals, and lubricants.
  - g. Decals and paper products.
  - h. Items purchased in kits.
7. The sender will be notified of any material received that is not acceptable.
8. Such material will be held for five working days from notification, pending instructions. If a reply is not received within five days, the material will be returned to the sender at his expense.
9. Credit on returned parts will be issued at dealer net price at time of the original purchase, less a 15% restocking charge.
10. In cases where an item is accepted, for which the original purchase document can not be determined, the price will be based on the list price that was effective twelve months prior to the RMA date.
11. Credit issued will be applied to future purchases only.

## PRICING AND REBATES

Prices are subject to change without prior notice. Price changes are effective on a specific date and all orders received on or after that date will be billed at the revised price. Rebates for price declines and added charges for price increases will not be made for stock on hand at the time of any price change.

Multiquip reserves the right to quote and sell direct to Government agencies, and to Original Equipment Manufacturer accounts who use our products as integral parts of their own products.

## SPECIAL EXPEDITING SERVICE

A \$35.00 surcharge will be added to the invoice for special handling including bus shipments, insured parcel post or in cases where Multiquip must personally deliver the parts to the carrier.

## LIMITATIONS OF SELLER'S LIABILITY

Multiquip shall not be liable hereunder for damages in excess of the purchase price of the item with respect to which damages are claimed, and in no event shall Multiquip be liable for loss of profit or good will or for any other special, consequential or incidental damages.

## LIMITATION OF WARRANTIES

No warranties, express or implied, are made in connection with the sale of parts or trade accessories nor as to any engine not manufactured by Multiquip. Such warranties made in connection with the sale of new, complete units are made exclusively by a statement of warranty packaged with such units, and Multiquip neither assumes nor authorizes any person to assume for it any other obligation or liability whatever in connection with the sale of its products. Apart from such written statement of warranty, there are no warranties, express, implied or statutory, which extend beyond the description of the products on the face hereof.

Effective: February 22, 2006



# OPERATION AND PARTS MANUAL

## HERE'S HOW TO GET HELP

PLEASE HAVE THE MODEL AND SERIAL  
NUMBER *ON-HAND* WHEN CALLING

### UNITED STATES

#### ***Multiquip Corporate Office***

18910 Wilmington Ave. Tel. (800) 421-1244  
Carson, CA 90746 Fax (800) 537-3927  
Contact: mq@multiquip.com

#### ***Mayco Parts***

800-306-2926 Fax: 800-672-7877  
310-537-3700 Fax: 310-637-3284

#### ***Service Department***

800-421-1244 Fax: 310-537-4259  
310-537-3700

#### ***MQ Parts Department***

800-427-1244 Fax: 800-672-7877  
310-537-3700 Fax: 310-637-3284

#### ***Warranty Department***

800-421-1244, Ext. 279 Fax: 310-537-1173  
310-537-3700, Ext. 279

#### ***Technical Assistance***

800-478-1244 Fax: 310-631-5032

### MEXICO

#### ***MQ Cipsa***

Carr. Fed. Mexico-Puebla KM 126.5 Tel: (52) 222-225-9900  
Momoxpan, Cholula, Puebla 72760 Mexico Fax: (52) 222-285-0420  
Contact: pmastretta@cipsa.com.mx

### CANADA

#### ***Multiquip***

4110 Industriel Boul. Tel: (450) 625-2244  
Laval, Quebec, Canada H7L 6V3 Fax: (450) 625-8664  
Contact: jmartin@multiquip.com

### UNITED KINGDOM

#### ***Multiquip (UK) Limited Head Office***

Hanover Mill, Fitzroy Street, Tel: 0161 339 2223  
Ashton-under-Lyne, Fax: 0161 339 3226  
Lancashire OL7 0TL  
Contact: sales@multiquip.co.uk

### BRAZIL

#### ***Multiquip***

Av. Evandro Lins e Silva, 840 - grupo 505 Tel: 011-55-21-3433-9055  
Barra de Tijuca - Rio de Janeiro Fax: 011-55-21-3433-9055  
Contact: cnavarro@multiquip.com.br, srentes@multiquip.com.br

© COPYRIGHT 2007, MULTIQUIP INC.

Multiquip Inc., Mikasa, and the MQ logo are registered trademarks of Multiquip Inc. and may not be used, reproduced, or altered without written permission. All other trademarks are the property of their respective owners and used with permission.

This manual MUST accompany the equipment at all times. This manual is considered a permanent part of the equipment and should remain with the unit if resold.

The information and specifications included in this publication were in effect at the time of approval for printing. Illustrations, descriptions, references and technical data contained in this manual are for guidance only and may not be considered as binding. Multiquip Inc. reserves the right to discontinue or change specifications, design or the information published in this publication at any time without notice and without incurring any obligations.

Your Local Dealer is:

