

OPERATION AND PARTS MANUAL



MODEL QP-205SH HIGH PRESSURE CENTRIFUGAL PUMP (Gasoline Engine)

Revision #1 (10/27/06)

**THIS MANUAL MUST ACCOMPANY
THE EQUIPMENT AT ALL TIMES.**



WARNING



CALIFORNIA — Proposition 65 Warning

Engine exhaust and some of its constituents are known to the State of California to cause cancer, birth defects and other reproductive harm.

HERE'S HOW TO GET HELP

PLEASE HAVE THE MODEL AND SERIAL
NUMBER *ON-HAND* WHEN CALLING

MULTIQUIP CORPORATE OFFICE

18910 Wilmington Ave.

Carson, CA 90746

Email: mq@multiquip.com

Internet: www.multiquip.com

800-421-1244

FAX: 310-537-3927

PARTS DEPARTMENT

800-427-1244

310-537-3700

FAX: 800-672-7877

FAX: 310-637-3284

MAYCO PARTS

800-306-2926

310-537-3700

FAX: 800-672-7877

FAX: 310-637-3284

SERVICE DEPARTMENT

800-478-1244

310-537-3700

FAX: 310-537-4259

TECHNICAL ASSISTANCE

800-478-1244

FAX: 310-631-5032

WARRANTY DEPARTMENT

800-421-1244, EXT. 279

310-537-3700, EXT. 279

FAX: 310-537-1173

© COPYRIGHT 2006, MULTIQUIP INC.

Multiquip Inc, the MQ logo is a registered trademarks of Multiquip Inc. and may not be used, reproduced, or altered without written permission. All other trademarks are the property of thier respective owners and used with permission.

This manual **MUST** accompany the equipment at all times. This manual is considered a permanent part of the equipment and should remain with the unit if resold.

The information and specifications included in this publication were in effect at the time of approval for printing. Illustrations are based on the *MQ QP-205SH High Pressure Centrifugal Pump*. Illustrations, descriptions, references and technical data contained in this manual are for guidance only and may not be considered as binding. Multiquip Inc. reserves the right to discontinue or change specifications, design or the information published in this publication at any time without notice and without incurring any obligations.

**To find the latest revision of this
publication, visit our website at:
www.multiquip.com**



**MultiquipQP-205SH
Gasoline Powered High
Pressure Centrifugal
Pump**

Here's How To Get Help 2
 Table of Contents 3
 Parts Ordering Procedures 4-5
 Safety Message Alert Symbols 6-7
 Rules For Safe Operation 8-9
 Pump Specifications/Dimensions 10
 Engine Specifications 11
 General Information 12
 Pump Components 13
 Basic Engine 14
 Pre-Inspection (Engine) 15
 Pre-Set-up (Pump) 16
 Initial Start-up (Engine) 17-18
 Maintenance (Pump) 20-21
 Maintenance (Engine) 22-23
 Preparation for Long-Term Storage 24
 Troubleshooting (Pump) 26
 Troubleshooting (Pump/Engine) 27
 Explanation Of Code In Remarks Column 28
 Suggested Spare Parts 29
 Pump Assy. 30-31

Honda GX160K1TX2 Engine

Air Cleaner (Dual) Assembly 32-33
 Camshaft Assembly 34-35
 Carburetor Assembly 36-37
 Control Assembly 38-39
 Crankcase Cover Assembly 40-41
 Crankshaft Assembly 42-43
 Cylinder Barrel Assembly 44-45
 Cylinder Head Assembly 46-47
 Fan Cover Assembly 48-49
 Flywheel Assembly 50-51
 Fuel Tank Assembly 52-53
 Ignition Coil Assembly 54-55
 Muffler Assembly 56-57
 Piston Assembly 58-59
 Recoil Starter Assembly 60-61
 Gasket Kit Assembly 63
 Labels 64-65
 Terms and Condition Of Sale — Parts 66

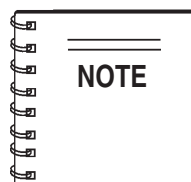

***Specification and part number
are subject to change without
notice.***

www.multiquip.com

**Ordering parts has never been easier!
Choose from three easy options:**



Order via Internet (Dealers Only):

Order parts on-line using Multiquip's SmartEquip website!

- View Parts Diagrams
- Order Parts
- Print Specification Information



If you have an MQ Account, to obtain a Username and Password, E-mail us at: parts@multiquip.com.

To obtain an MQ Account, contact your District Sales Manager for more information.

Goto www.multiquip.com and click on **Order Parts** to log in and save!

Use the **internet** and qualify for a **5% Discount** on *Standard orders* for all orders which include complete part numbers.*

Note: Discounts Are Subject To Change



Order via Fax (Dealers Only):

All customers are welcome to order parts via Fax.

Domestic (US) Customers dial:
1-800-6-PARTS-7 (800-672-7877)

Fax your order in and qualify for a **3% Discount** on *Standard orders* for all orders which include complete part numbers.*

Note: Discounts Are Subject To Change



Order via Phone: Domestic (US) Dealers Call:
1-800-427-1244

Non-Dealer Customers:

Contact your local Multiquip Dealer for parts or call 800-427-1244 for help in locating a dealer near you.



International Customers should contact their local Multiquip Representatives for Parts Ordering information.

When ordering parts, please supply:

- | | |
|--|--|
| <ul style="list-style-type: none"> <input type="checkbox"/> Dealer Account Number <input type="checkbox"/> Dealer Name and Address <input type="checkbox"/> Shipping Address (if different than billing address) <input type="checkbox"/> Return Fax Number <input type="checkbox"/> Applicable Model Number <input type="checkbox"/> Quantity, Part Number and Description of Each Part | <ul style="list-style-type: none"> <input type="checkbox"/> Specify Preferred Method of Shipment: <ul style="list-style-type: none"> <input checked="" type="checkbox"/> Fed Ex/UPS <input checked="" type="checkbox"/> DHL <input type="checkbox"/> Priority One <input checked="" type="checkbox"/> Truck <input type="checkbox"/> Ground <input type="checkbox"/> Next Day <input type="checkbox"/> Second/Third Day |
|--|--|

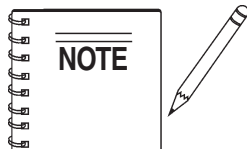

Unless otherwise indicated by customer, all orders are treated as *Standard Orders* and will ship within 24 hours. We will make every effort to ship *Air Shipments* the same day the order is received, if received prior to 2PM PST. *Stock Orders* must be noted on fax or web order form.

WE ACCEPT ALL MAJOR CREDIT CARDS!



QP-205SH — SAFETY MESSAGE ALERT SYMBOLS

FOR YOUR SAFETY AND THE SAFETY OF OTHERS!

Safety precautions should be followed at all times when operating this equipment. Failure to read and understand the Safety Messages and Operating Instructions could result in injury to yourself and others.

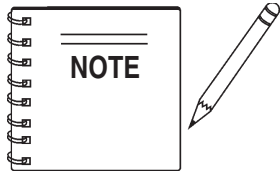

This Owner's Manual has been developed to provide complete instructions for the safe and efficient operation of the Multiquip **Model QP-205SH High Pressure Centrifugal Pump**. Refer to the engine manufacturers instructions for data relative to its safe operation.

Before using these pumps, ensure that the operating individual has read and understands all instructions in this manual.

SAFETY MESSAGE ALERT SYMBOLS

The three (3) Safety Messages shown below will inform you about potential hazards that could injure you or others. The Safety Messages specifically address the level of exposure to the operator, and are preceded by one of three words: **DANGER**, **WARNING**, or **CAUTION**.

DANGER

You **WILL** be **KILLED** or **SERIOUSLY INJURED** if you **DO NOT** follow these directions.

WARNING

You **CAN** be **KILLED** or **SERIOUSLY INJURED** if you **DO NOT** follow these directions.

CAUTION

You **CAN** be **INJURED** if you **DO NOT** follow these directions.

Potential hazards associated with the QP-205SH Centrifugal Pump operation will be referenced with Hazard Symbols which appear throughout this manual, and will be referenced in conjunction with Safety Message Alert Symbols.

HAZARD SYMBOLS

Lethal Exhaust Gases



Engine exhaust gases contain poisonous carbon monoxide. This gas is colorless and odorless, and can cause death if inhaled. **NEVER** operate this equipment in a confined area or enclosed structure that does not provide ample free flow air.

Explosive Fuel



GASOLINE is extremely flammable, and its vapors can cause an explosion if ignited. **DO NOT** start the engine near spilled fuel or combustible fluids. **DO NOT** fill the fuel tank while the engine is running or hot. **DO NOT** overfill tank, since spilled fuel could ignite if it comes into contact with hot engine parts or sparks from the ignition system. Store fuel in approved containers, in well-ventilated areas and away from sparks and flames. **NEVER** use fuel as a cleaning agent.

Burn Hazards



Engine components can generate extreme heat. To prevent burns, **DO NOT** touch these areas while the engine is running or immediately after operations. Never operate the engine with heat shields or heat guards removed.

Rotating Parts



NEVER operate equipment with covers, or guards removed. Keep fingers, hands, hair and clothing away from all moving parts to prevent injury.

QP-205SH — SAFETY MESSAGE ALERT SYMBOLS



Accidental Starting



OFF

ALWAYS place the engine ON/OFF switch in the **OFF** position when the pump is not in use.



Respiratory Hazard



ALWAYS wear approved respiratory protection.



Sight and Hearing hazard

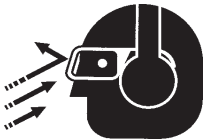

ALWAYS wear approved eye and hearing protection.



Equipment Damage Messages

Other important messages are provided throughout this manual to help prevent damage to your pump, other property, or the surrounding environment.

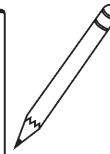
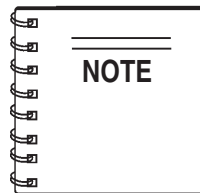

This pump, other property, or the surrounding environment could be damaged if you do not follow instructions.

QP-205SH — RULES FOR SAFE OPERATION

DANGER

Failure to follow instructions in this manual may lead to serious injury or even death! This equipment is to be operated by trained and qualified personnel only! This equipment is for industrial use only.

The following safety guidelines should always be used when operating the **centrifugal pump**:

GENERAL SAFETY

- **DO NOT** operate or service this equipment before reading this entire manual.



- This equipment should not be operated by persons under 18 years of age.

- **NEVER** operate this equipment without proper protective clothing, shatterproof glasses, steel-toed boots and other protective devices required by the job.



- **NEVER** operate this equipment when not feeling well due to fatigue, illness or taking medicine.



- **NEVER** operate this equipment under the influence of drugs or alcohol.



- Whenever necessary, replace nameplate, operation and safety decals when they become difficult read.

- **ALWAYS** check the machine for loosened threads or bolts before starting.

- **ALWAYS** wear proper respiratory (mask) hearing and eye protection equipment when operating the pump.



- **NEVER** touch the hot exhaust manifold, muffler or cylinder. Allow these parts to cool before servicing engine or pump.



- **High Temperatures** – Allow the engine to cool before adding fuel or performing service and maintenance functions. Contact with *hot* components can cause serious burns.

- The engine of this pump requires an adequate free flow of cooling air. **NEVER!** operate the pump in any enclosed or narrow area where free flow of the air is restricted. If the air flow is restricted it will cause serious damage to the pump or engine and may cause injury to people and property. Remember the pump's engine gives off **DEADLY** gases.

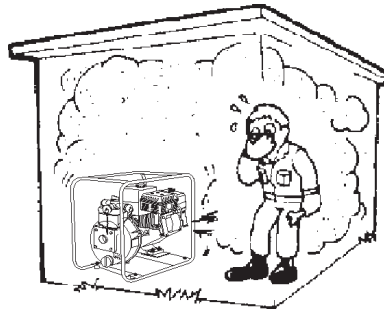

- **ALWAYS** refuel in a well-ventilated area, away from sparks and open flames.

- **ALWAYS** use extreme caution when working with **flammable** liquids. When refueling, **stop the engine** and allow it to cool. **DO NOT** smoke around or near the machine. Fire or explosion could result from fuel vapors, or if fuel is spilled on a hot engine.

- **NEVER** operate the pump in an **explosive atmosphere** or near combustible materials. An explosion or fire could result causing severe **bodily harm or even death**.

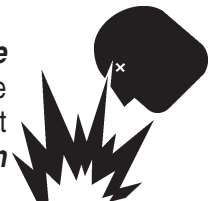

- Topping-off to filler port is dangerous, as it tends to spill fuel.
- Refer to the **Engine Owner's Manual** for engine technical questions or information.
- **NEVER** use accessories or attachments, which are not recommended by Multiquip for this equipment. Damage to the equipment and/or injury to user may result.
- Manufacturer does not assume responsibility for any accident due to equipment modifications.

QP-205SH — RULES FOR SAFE OPERATION

- **NEVER** Run engine without air cleaner. Severe engine damage may occur.
- **ALWAYS** read, understand, and follow procedures in Operator's Manual before attempting to operate equipment.
- **ALWAYS** be sure the operator is familiar with proper safety precautions and operation techniques before using pump.
- **ALWAYS** store equipment properly when it is not being used. Equipment should be stored in a clean, dry location out of the reach of children.
- **NEVER** leave the pump unattended, turn off engine when unattended.
- Unauthorized equipment modifications will void all warranties.
- **NEVER** pump volatile, explosive, flammable or low flash point fluids. These fluids could ignite or explode.
- **NEVER** operate the pump in an **explosive** atmosphere.
- Before starting the pump, check that the clean-out cover is securely fasten.
- **ALWAYS** ensure pump is on level ground before use.
- Become familiar with the components of the pump before operating.
- **ALWAYS** replace any worn or damaged warning decals.
- **NEVER** pump corrosive chemicals or water containing toxic substances. These fluids could create serious health and environmental hazards. Contact local authorities for assistance.
- **NEVER** open the priming plug when pump is hot. Hot water inside could be pressurized much like the radiator of an automobile. Allow pump to cool to the touch before loosening plug.
- **NEVER** open the pump housing during operation or start the pump with the clean-out cover removed. The rotating impeller inside the pump can cut or sever objects caught in it.
- **NEVER** block or restrict flow from discharge hose. Remove kinks from discharge line before starting pump. Operation with a blocked discharge line can cause water inside pump to overheat.
- **ALWAYS** fill the pump casing with water before starting the engine. Failure to maintain water inside the pump housing will cause severe damage to the pump.
- In winter drain water from pump housing to prevent freezing.

■ **High Temperatures** – Always stop engine and allow the engine to cool before adding fuel, oil or performing service and maintenance functions. Contact with *hot* components can cause serious burns.

■ **NEVER** disconnect any "**emergency or safety devices**". These devices are intended for operator safety. Disconnection of these devices can cause severe injury, bodily harm or even death! Disconnection of any of these devices will void all warranties.

Maintenance Safety

- **NEVER** lubricate components or attempt service on a running machine.
- **ALWAYS** allow the machine a proper amount of time to cool before servicing.
- Keep the machinery in proper running condition.
- Fix damage to the machine immediately and always replace broken parts, or missing decals.
- Dispose of hazardous waste properly. Examples of potentially hazardous waste are used motor oil, fuel and fuel filters.
- **DO NOT** use food or plastic containers to dispose of hazardous waste.
- **DO NOT** pour waste, oil or fuel directly onto the ground, down a drain or into any water source.

Emergencies

■ **ALWAYS** know the location of the nearest **fire extinguisher**.



■ **ALWAYS** know the location of the nearest **first aid kit**.



■ In emergencies **always** know the location of the nearest phone or **keep a phone on the job site**. Also know the phone numbers of the nearest **ambulance, doctor** and **fire department**. This information will be invaluable in the case of an emergency.

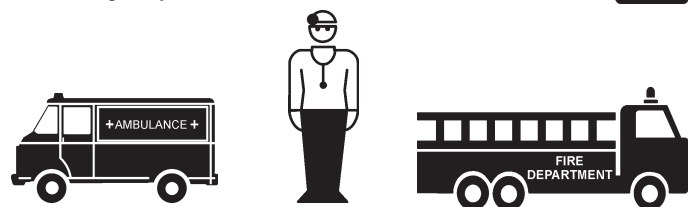

QP-205SH — SPECIFICATIONS/DIMENSIONS (PUMP)

Table 1. Specifications (Pump)		
Pump	Model	QP-205SH
	Type	Centrifugal Pump
	Suction Size	2.00 in. (51 mm.)
	Discharge Size	1.00 in. (25 mm.) 2 ea. 1.50 in. (38 mm.) 1 ea.
	Maximum Pumping Capacity	106 gallons/minute (401 liters/minute)
	Max. Lift	25 ft. (7.62 meters)
	Max. Head	246 ft. (75.0 meters)
Dimension (L x W x H)		20.0 x 15.0 X 16.5 in. (51 X 38 X 42 cm.)
Dry Net Weight		64 lbs. (29 Kg.)

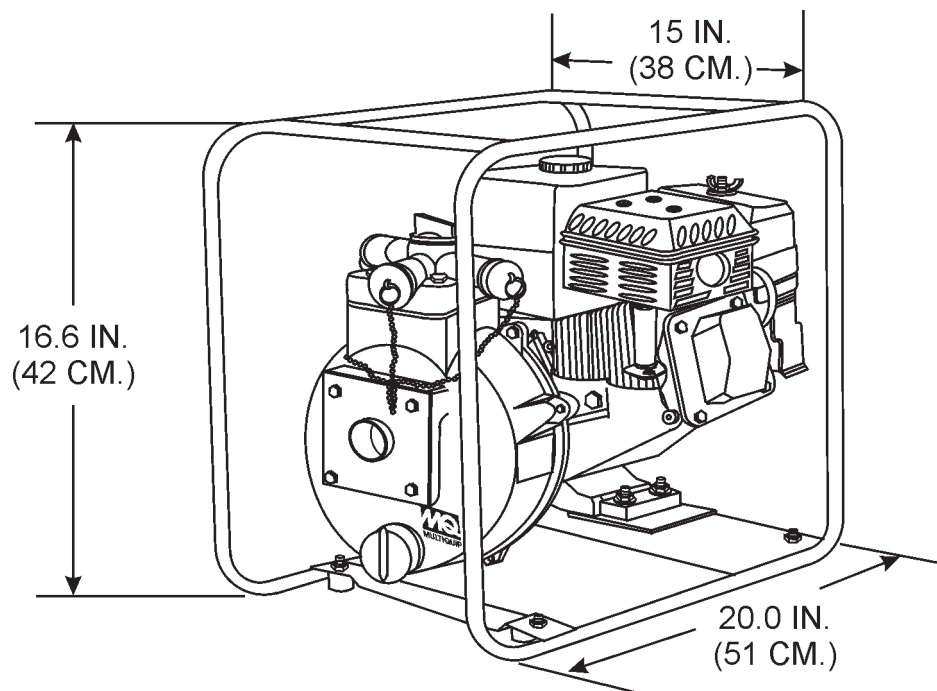

Figure 1. QP-205SH Dimensions

Table 2. Specifications (Engine)

Engine	Model	HONDA GX160K1TX2
	Type	Air-cooled 4 stroke, Single Cylinder, OHV, Horizontal Shaft Gasoline Engine
	Bore X Stroke	2.7 in. x 1.8 in. (68 mm x 45 mm)
	Displacement	163 cc (9.9 cu-in)
	Max Output	5.5 H.P./3600 R.P.M.
	Fuel Tank Capacity	Approx. 0.95 U.S. gallons (3.6 liters)
	Fuel	Unleaded Automobile Gasoline
	Lube Oil Capacity	.60 liters (0.63 qts)
	Speed Control Method	Centrifugal Fly-weight Type
	Starting Method	Recoil Start
Dimension (L x W x H)		12.0 x 14.4 x 13.2 in. (304 x 362 x 335 mm)
Dry Net Weight		33.1 lbs (15 Kg.)

QP-205SH — GENERAL INFORMATION

APPLICATION

The **QP205SH centrifugal pump** is a high pressure pump designed to be used for de-watering applications. The suction port on the QP-205SH uses a 2-inch diameter opening. There are three discharge ports on the pump, 2 are 1-inch in diameter and the third is 1.5-inches in diameter. This pump can discharge water at a rate of approximately 106 gallons/minute (gpm) or 401 liters/minute (lpm).

Centrifugal or self priming pumps are designed to purge air from the suction line and create a partial vacuum in the pump body. The reduced atmospheric pressure inside the pump allows water to flow through the suction line and into the pump body. The centrifugal force created by the rotating impeller pressurizes the water and expels it from the pump.

Power Plant

This trash pump is powered by an 5.5 horsepower air cooled 4-stroke, single cylinder **HONDA GX-160** gasoline engine that incorporates a low "**Oil Alert Feature**".

Oil Alert Feature

In the event of **low oil** or **no oil**, the HONDA GX-160 engine has a built-in oil alarm engine shut-down feature. In the event the oil level is low the engine will automatically shut-down.

Standard Centrifugal Pump

Standard centrifugal pumps provide an economical choice for general purpose dewatering. These types of pumps should only be used in **clear water** applications (agricultural, industrial, residential) as they have a limited soil handling capability of only 10% by volume.

Suction Lift

This pump is intended to be used for dewatering applications and is capable of suction lifts up to 25 feet at sea level. For optimal suction lift performance keep the suction hose or line as short as possible. In general always place the pump as close to the water as possible.

Pump Support

The pump should always be placed on **solid stationary ground** in a level position.

NEVER place the pump on **soft soil**. The suction hose or pipe connection should always be checked for tightness and leaks. A small suction leak in the hose or fittings could prevent the pump from priming.

Elevation

Higher elevations will effect the performance of the pump. Due to less atmospheric pressure at higher altitudes, pumps **DO NOT** have the priming ability that they have at sea level. This is due to the "thinner air" or lack of oxygen at higher altitudes.

A general rule of thumb is that for every 1,000 feet of elevation above sea level a pump will lose one foot of priming ability.

For example, in Flagstaff, Arizona where the elevation is approximately 7,000 feet, the pump would have a suction lift of only 18 feet rather than the 25 feet at sea level. Table 3 shows suction lift at various elevations.

Table 3. Suction Lift at Various Elevations

Altitude Feet (Meters)	Suction Lift in Feet (Meters)			
	10.0 (3.048)	15.0 (4.572)	20.0 (6.096)	25.0 (7.620)
Sea Level	10.0 (3.048)	15.0 (4.572)	20.0 (6.096)	25.0 (7.620)
2,000 (610)	8.80 (2.680)	13.2 (4.023)	17.6 (5.364)	22.0 (6.705)
4,000 (1,219)	7.80 (2.377)	11.7 (3.566)	15.6 (4.754)	19.5 (5.943)
6,000 (1,829)	6.90 (2.103)	10.4 (3.169)	13.8 (4.206)	17.3 (5.273)
8,000 (2,438)	6.20 (1.889)	9.30 (2.834)	12.4 (3.779)	15.5 (4.724)
10,000 (3,048)	5.70 (1.737)	8.60 (2.621)	11.4 (3.474)	14.3 (4.358)

Table 4 shows percentage drops in performance as elevation increases.

Table 4. Performance Loss at Various Elevations

Altitude Feet (Meters)	Discharge Flow	Discharge Head
Sea Level	100%	100%
2,000 (610)	97%	95%
4,000 (1,219)	95%	91%
6,000 (1,829)	93%	87%
8,000 (2,438)	91%	83%
10,000 (3,048)	88%	78%

QP-205SH — PUMP COMPONENTS

Figure 2 shows a typical application using the QP-205SH centrifugal pump. Please note that this pump is intended for the removal of clean water and water containing some debris and solids. Maximum size of solids should not exceed .18 inch (6 mm) in diameter. **DO NOT** set strainer on bottom of water bed. Placing the strainer above the water bed will prevent the pump from drawing in excessive amounts of sand and foreign debris.

Figure 2. QP-205SH Pump Application

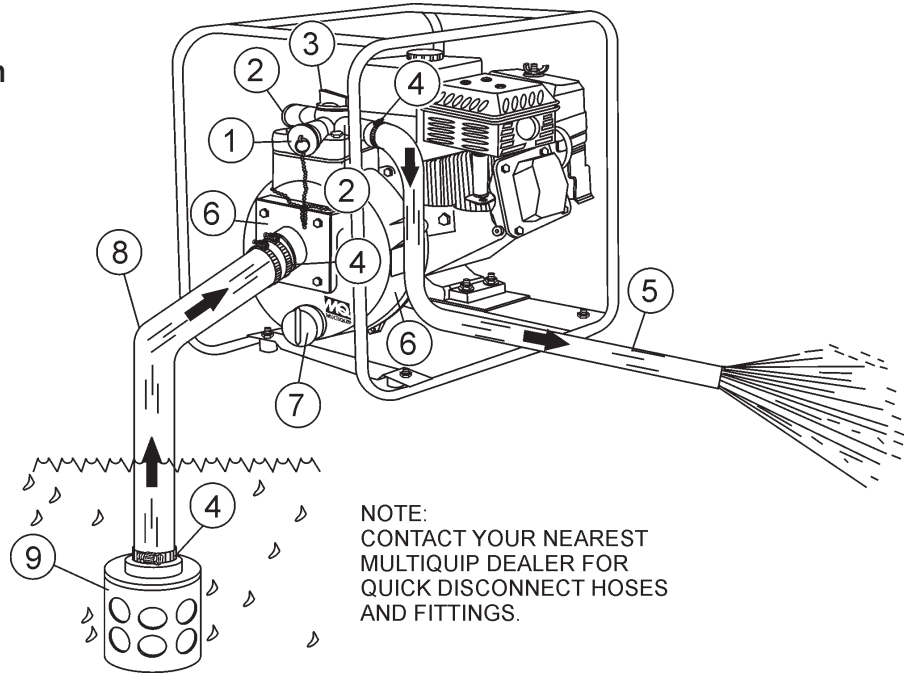

1. **Discharge Port 1.5-Inch** – Connect a flexible rubber hose to this 1.5-inch discharge port (1) on the pump. Make sure that the hose lays flat and is not kinked. Use only recommended type discharge hose. Contact Multiquip parts department for ordering information.
2. **Discharge Port 1-Inch** – Connect a flexible rubber hose to these 1-inch discharge ports (2) on the pump. Make sure that the hose lays flat and is not kinked. Use only recommended type discharge hose. Contact Multiquip parts department for ordering information.
3. **Fill Cap** – Prior to operation, the pump casing should be filled with water. Remove this cap to add water to the pump. After the initial prime, a sufficient amount of water will be retained in the casing so that the operator will not need to re-prime later.
4. **Worm Clamp** – Used to secure the hose to the inlet and outlet ports on the pump. Use two clamps to secure the hose on the inlet side of the pump.
5. **Discharge Hose** – Connect a flexible rubber hose to the discharge port on the pump. Make sure that the hose lays flat and is not kinked. Use only recommended type discharge hose. Contact Multiquip parts department for ordering information.
6. **Pump** – The model QP-205SH is 2-inch centrifugal pump and should only be used in only **clear water** applications (agricultural, industrial, residential) as they have a limited solid handling capability of only 10% by volume.
7. **Drain Plug** – Remove this plug to drain water from the pump.
8. **Suction Hose** – Connect a flexible rubber hose to the suction port on the pump. Make sure that the hose lays flat and is not kinked. Use only recommended type suction hose. Contact Multiquip parts department for ordering information.
9. **Strainer** – Always attach a strainer to bottom side of the suction hose to prevent large objects and debris from entering the pump. Strainer should be positioned so that it will remain completely under water. Running the pump with the strainer above water for long periods can damage pump.

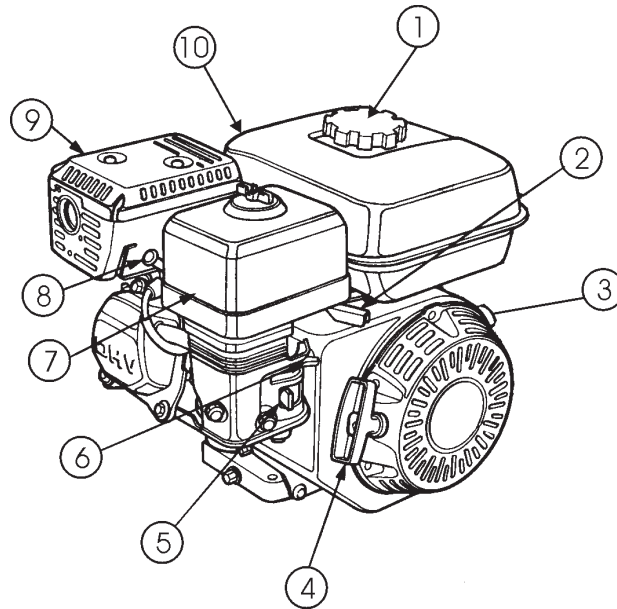

Figure 3. Engine Controls and Components

INITIAL SERVICING

The engine (Figure 3) must be checked for proper lubrication and filled with fuel prior to operation. Refer to the manufacturer's engine manual for instructions & details of operation and servicing. The engine shown above is a **HONDA** engine, operation for other types of engines may vary somewhat.

1. **Fuel Filler Cap** – Remove this cap to add unleaded gasoline to the fuel tank. Make sure cap is tightened securely. **DO NOT** over fill.

DANGER

Adding fuel to the tank should be done only when the engine is stopped and has had an opportunity to cool down. In the event of a fuel spill, **DO NOT** attempt to start the engine until the fuel residue has been completely wiped up, and the area surrounding the engine is dry.

6. **Choke Lever** – Used in the starting of a cold engine, or in cold weather conditions. The choke enriches the fuel mixture.
7. **Air Cleaner** – Prevents dirt and other debris from entering the fuel system. Remove wing-nut on top of air filter canister to gain access to filter element.

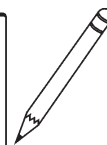
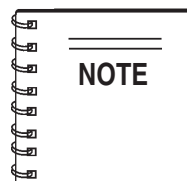

Operating the engine without an air filter, with a damaged air filter, or a filter in need of replacement will allow dirt to enter the engine, causing rapid engine wear.

WARNING

Engine components can generate extreme heat. To prevent burns, **DO NOT** touch these areas while the engine is running or immediately after operating. **NEVER** operate the engine with the muffler removed.



2. **Throttle Lever** – Used to adjust engine RPM speed (lever advanced forward **SLOW**, lever back toward operator **FAST**).
3. **Engine ON/OFF Switch** – ON position permits engine starting, OFF position stops engine operations.
4. **Recoil Starter (pull rope)** – Manual-starting method. Pull the starter grip until resistance is felt, then pull briskly and smoothly.
5. **Fuel Valve Lever** – **OPEN** to let fuel flow, **CLOSE** to stop the flow of fuel.

8. **Spark Plug** – Provides spark to the ignition system. Set spark plug gap to 0.6 - 0.7 mm (0.028 - 0.031 inch). Clean spark plug once a week.
9. **Muffler** – Used to reduce noise and emissions.
10. **Fuel Tank** – Holds unleaded gasoline. For additional information refer to engine owner's manual.

QP-205SH — PRE-INSPECTION (ENGINE)

CAUTION

NEVER operate the pump in a confined area or enclosed area structure that does not provide ample **free flow of air**.



ALWAYS wear approved eye and hearing protection before operating the pump.

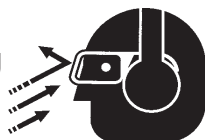

Before Starting

1. Read safety instructions at the beginning of manual.
2. Clean the pump, removing dirt and dust, particularly the engine cooling air inlet, carburetor and air cleaner.
3. Check the air filter for dirt and dust. If air filter is dirty, replace air filter with a new one as required.
4. Check carburetor for external dirt and dust. Clean with dry compressed air.
5. Check fastening nuts and bolts for tightness.



Engine Oil Check

1. To check the engine oil level, place the pump on secure level ground with the engine stopped.
2. Remove the filler dipstick from the engine oil filler hole (Figure 4) and wipe clean.

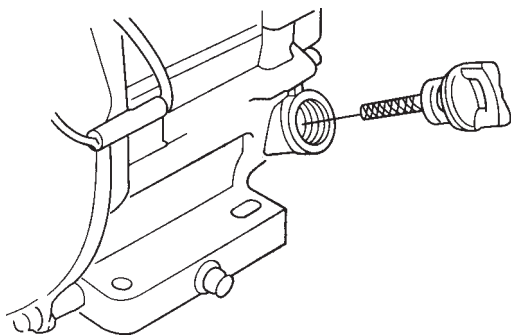

Figure 4. Engine Oil Dipstick (Removal)

3. Insert and remove the dipstick without screwing it into the filler neck. Check the oil level shown on the dipstick.
4. If the oil level is low (Figure 5), fill to the edge of the oil filler hole with the recommended oil type (Table 5). Maximum oil capacity is 1.16 quarts (1.1 liters)

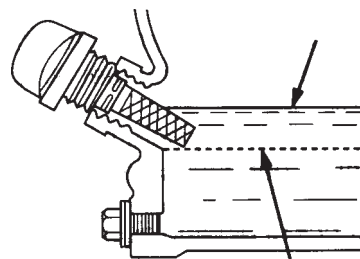

Figure 5. Engine Oil Dipstick (Oil Level)

Table 5. Oil Type

Season	Temperature	Oil Type
Summer	25°C or Higher	SAE 10W-30
Spring/Fall	25°C~10°C	SAE 10W-30/20
Winter	0°C or Lower	SAE 10W-10

DANGER EXPLOSIVE FUEL

Motor fuels are highly flammable and can be dangerous if mishandled. **DO NOT** smoke while refueling. **DO NOT** attempt to refuel the pump if the engine is **hot!** or **running**.



Fuel Check

1. Remove the gasoline cap located on top of fuel tank.
2. Visually inspect to see if the fuel level is low. If fuel is low, replenish with unleaded fuel.
3. When refueling, be sure to use a strainer for filtration. **DO NOT** top-off fuel. Wipe up any spilled fuel **immediately!**

Before Starting

1. Read safety instructions at the beginning of manual.
2. Place pump as near to water as possible, on a firm flat, level surface.
3. To prime pump, remove fill cap (Figure 2) and fill pump casing with water. If the pump casing is not filled with water before starting, it will not begin pumping.

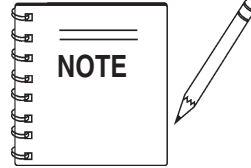

Suction and discharge hoses are available from Multiquip. Contact your nearest dealer for more information.

5. The discharge hose is usually a **collapsible** (thin-walled) hose, however if a thin-walled discharge hose is not available, a rigid suction hose can be substituted in its place.
6. Make sure the **suction strainer** (Figure 2) is clean and securely attached to the water end of the suction hose. The strainer is designed to protect the pump by preventing large objects from being pulled into the pump.

CAUTION

Pump casing **must** be filled with water before using pump. Otherwise pump will not be able to begin pumping.

WARNING

DO NOT open **fill cap** if pump is **hot!** Water inside may be under pressure.



CAUTION

The strainer should be positioned so it will remain completely **under water**. Running the pump with the strainer above water for long periods can damage the pump.

DANGER

DO NOT pump flammable fluids, corrosive chemicals or fluids containing toxic substances. These fluids can create potentially dangerous health and environmental hazards. Contact local authorities for assistance.

4. Check for **leaks** between pump and engine. If water is leaking between the pump and engine housing, the seal inside the pump may be worn or damaged. Continued operation of the pump is not recommended. Further usage of the pump under these conditions may cause severe water damage to engine.

Hoses and Clamps

1. Check that all hoses are **securely** attached to the pump. Make certain suction hose (Figure 2) does not have any air leakage. Tighten hose clamps and couplings as required.
2. It is recommended that 2 clamps be used when securing the suction hose to the inlet side (suction) of the pump.
3. Remember suction hoses must be **rigid** enough not to collapse when the pump is in operation.
4. Check that the **discharge** hose (Figure 2) is not restricted. Place hose so that it lays as straight as it is possible on the ground. Remove any twists or sharp bends from hose which may block the flow of water.

CAUTION

This pump uses a water-cooled **mechanical seal** to prevent water from seeping into the engine. The passage of water through the pump casing lubricates the seal and prevents it from overheating. **NEVER!** operate the pump without water in the casing as this will cause damage to the mechanical seal.

CAUTION

DO NOT attempt to operate the pump until the Safety, General Information and Inspection sections of this manual have been *read and thoroughly understood*.



This section is intended to assist the operator with the *initial start-up* of the trash pump. It is extremely important that this section be read carefully before attempting to use the pump in the field.

Starting the Engine (HONDA engine)

1. Place the engine **fuel valve lever** (Figure 6) to the "ON" position.

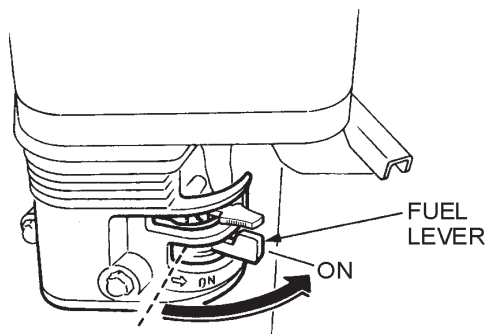

Figure 6. Engine Fuel Valve Lever (ON Position)

2. Move the **throttle lever** (Figure 7) away from the slow position, about 1/3 of the way toward the fast position.

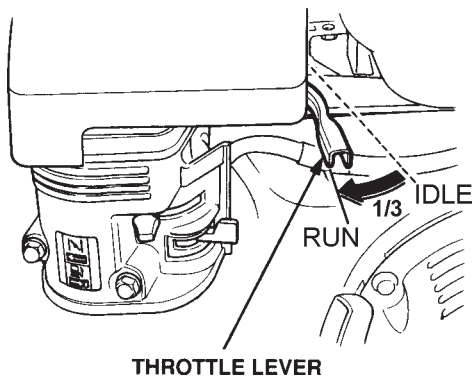

Figure 7. Throttle Lever (1/3 Start Position)

3. Place the **choke lever** (Figure 8) in the "OPEN" position if starting a *cold engine*.

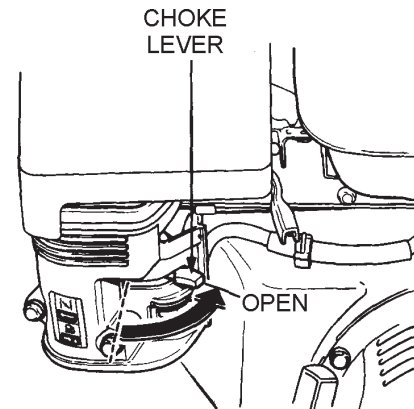

Figure 8. Engine Choke Lever (Open)

4. Place the **choke lever** (Figure 9) in the "CLOSED" position if starting a *warm engine* or the *temperature is warm*.

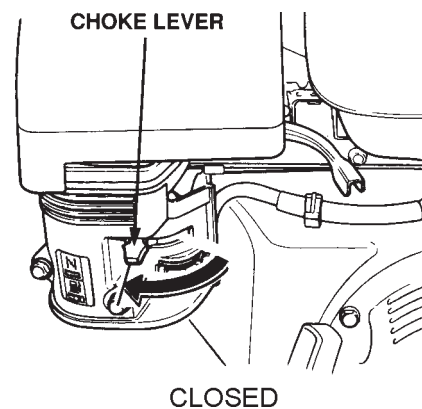

Figure 9. Engine Choke Lever (Closed)

5. Place the **engine ON/OFF switch** (Figure 10) in the "ON" position.

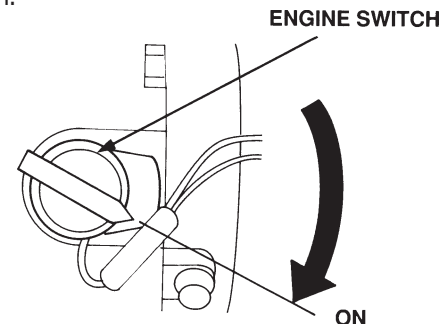

Figure 10. Engine ON/OFF Switch (ON Position)

- Grasp the starter grip (Figure 11) and slowly pull it out. The resistance becomes the hardest at a certain position, corresponding to the compression point. Pull the starter grip briskly and smoothly for starting.

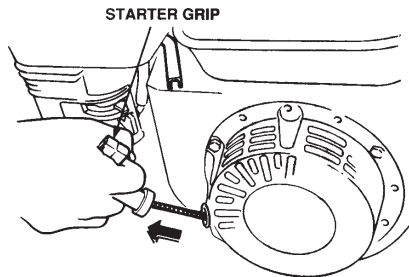

Figure 11. Starter Grip

- If the engine has started, slowly return the choke lever (Figure 12) to the **CLOSED** position. If the engine has not started repeat steps 1 through 6.

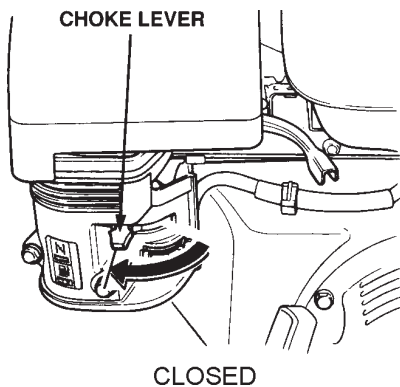

Figure 12. Choke Lever (Closed)

- Before the pump is placed into operation, run the engine for several minutes. Check for fuel leaks, and noises that would associate with a loose component.
- To begin pumping, place the throttle lever (Figure 13) in the "RUN" position.

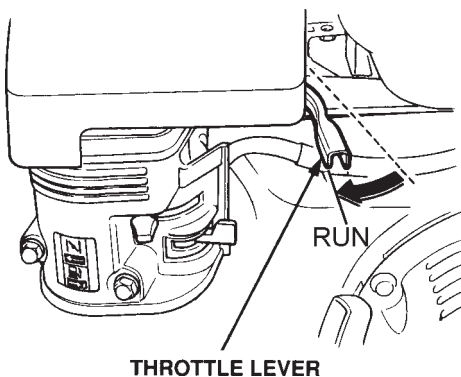

Figure 13. Throttle Lever (Run)

CAUTION

ALWAYS run engine at **full speed** while pumping.

Stopping The Engine

Normal Shutdown

- Move the throttle lever to the **IDLE** position (Figure 14) and run the engine for three minutes at low speed.

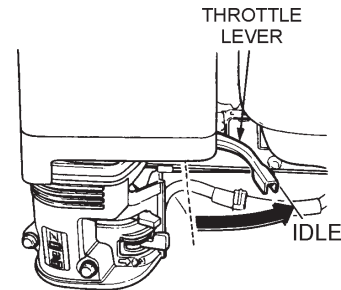

Figure 14. Throttle Lever (Idle)

- After the engine **cools**, turn the engine ON/OFF switch to the "OFF" position (Figure 15).

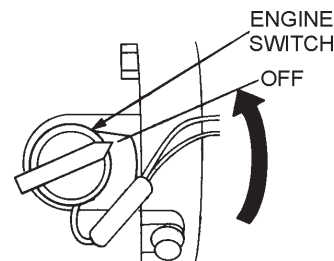

Figure 15. Engine ON/OFF Switch (OFF)

- Place the **fuel shut-off lever** (Figure 16) in the **OFF** position.

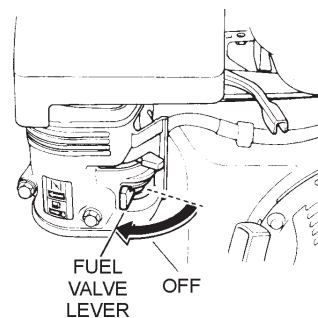

Figure 16. Fuel Valve Lever (OFF)

Emergency Showdown

- Move the throttle lever quickly to the **IDLE** position, and place the engine ON/OFF switch in the **OFF** position.

Pump Vacuum Test

CAUTION

DO NOT attempt to start the engine unless the pump has previously been **primed** with water. Severe pump damage will occur if pump has not been primed.

To perform the pump vacuum test do the following:

1. Remove the pump fill cap (Figure 2), and fill the pump with water.
2. Start the engine as outlined in the initial start-up section, and wait for the pump to begin pumping.
3. As shown in Figure 17 (next page), place a water hose inside the discharge opening of the pump, and turn on the water. This flow of water into the discharge opening will **prevent** the pump from running dry.
4. Place the **Pump Vacuum Tester** (P/N 7000030) over the pump suction (inlet) opening (Figure 17) with the vacuum gauge facing upwards. It may be necessary to apply a small amount of water around the rubber seal of the vacuum tester to make a good suction fit.
5. Check and make sure that there are no air leaks between the vacuum tester and the inlet port on the pump. If air leaks are present reseal vacuum tester.
6. Run the pump for a few minutes while monitoring the vacuum gauge. If the gauge indicates a reading between -25 and -20 in. Hg. (inches of mercury) then it can be assumed that the pump is working correctly.

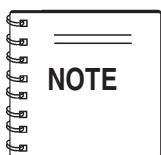

25 in. Hg (inches of mercury) translates into 25 feet of lift at **sea level**.

7. If the vacuum tester gauge indicates a reading **below** -20 in. Hg, it can then be assumed that the pump is not functioning correctly, and corrective action needs to be taken.
6. To test the **flapper valve**, shut down the engine. The vacuum tester should remain attached to the pump suction inlet port by vacuum. This indicates the pump's flapper valve is seating properly to hold water in the suction hose when the engine is stopped. This prevents backflow and allows for faster priming when the engine is restarted.

Pump Cleaning

After pumping water containing large amounts of dirt and debris, perform the following:

1. Remove the drain plug from the pump housing (Figure 2) and drain any water left in the pump.
2. Loosen the two locking hand knobs (turn counter-clockwise) and remove **clean-out cover**.
3. Clean and remove dirt, debris from pump casing. Inspect impeller and volute for wear. Replace any damaged or worn parts.

CAUTION

The impeller may develop **sharp edges**. Use extreme care when cleaning around the impeller to prevent being cut.

CAUTION

DO NOT RUN PUMP WITHOUT WATER.

PLACE VACUUM TESTER OVER PUMP SUCTION PORT

DISCHARGE PORT

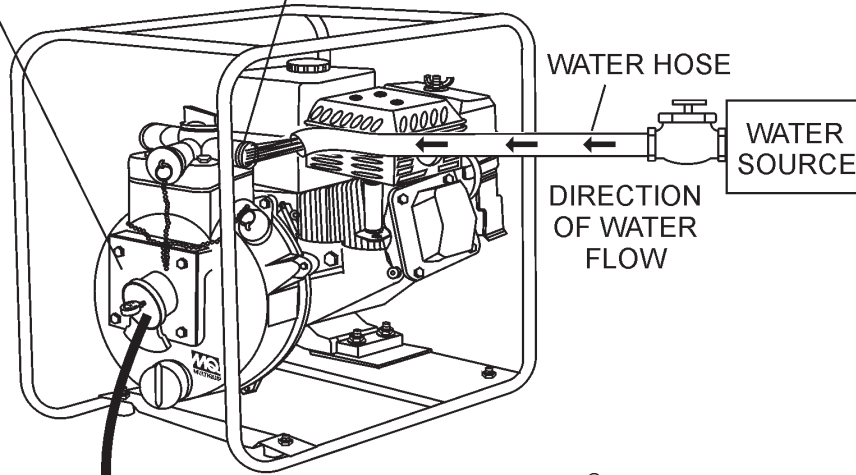

NOTE

Pressure reading may vary depending on altitude. See Tables 3 and 4 on page 12.

ACCEPTABLE READING SHOULD BE BETWEEN -25 AND -20 IN. HG.

25 IN. HG. TRANSLATES INTO 25 FEET OF LIFT AT SEA LEVEL.

PUMP VACUUM TESTER

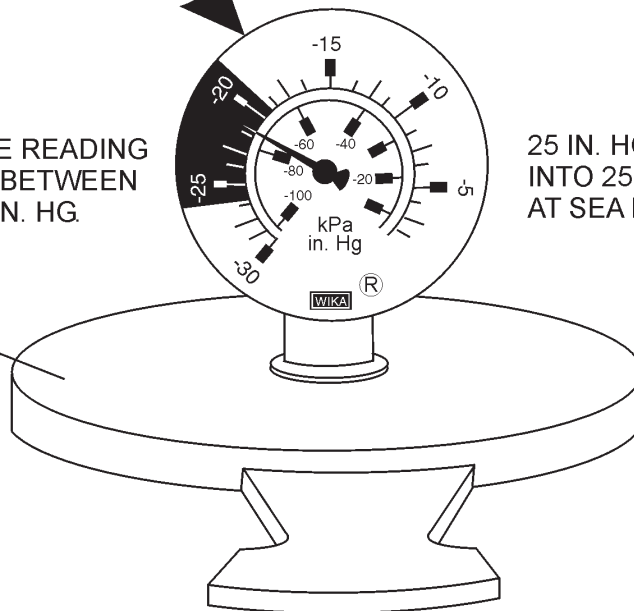

Figure 17. Pump Vacuum Tester

Engine Maintenance

Perform engine maintenance procedures as referenced by Table 6 below:

Table 6. Engine Maintenance Schedule							
DESCRIPTION (3)	OPERATION	BEFORE	FIRST MONTH OR 10 HRS.	EVERY 3 MONTHS OR 25 HRS.	EVERY 6 MONTHS OR 50 HRS.	EVERY YEAR OR 100 HRS.	EVERY 2 YEARS OR 200 HRS.
Engine Oil	CHECK	X					
	CHANGE		X				
Air Cleaner	CHECK	X					
	CHANGE			X (1)			
All Nuts & Bolts	Re-tighten If Necessary	X					
Spark Plug	CHECK-CLEAN				X		
	REPLACE						X
Cooling Fins	CHECK				X		
Spark Arrester	CLEAN					X	
Fuel Tank	CLEAN					X	
Fuel Filter	CHECK					X	
Idle Speed	CHECK-ADJUST					X (2)	
Valve Clearance	CHECK-ADJUST						X (2)
Fuel lines	CHECK	Every 2 years (replace if necessary) (2)					

(1) Service more frequently when used in **DUSTY** areas.

(2) These items should be serviced by your servic dealer, unless you have the proper tools and are mechanically proficient. Refer to the HONDA shop Manual for service procedures

(3) For commercial use, log hours of operation to determine proper maintenance intervals.

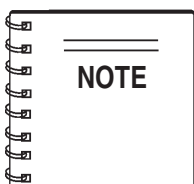

Reference manufacturer engine manual for specific servicing instructions.

Maintenance

Perform the engine maintenance procedures as indicated below:

DAILY

- Thoroughly remove dirt and oil from the engine and control area. Clean or replace the air cleaner elements as necessary. Check and retighten all fasteners as necessary. Check the spring box and bellows for oil leaks. Repair or replace as needed.

WEEKLY

- Remove the fuel filter cap and clean the inside of the fuel tank.
- Remove or clean the filter at the bottom of the tank.
- Remove and clean the spark plug (Figure 18), then adjust the spark gap to 0.028 ~0.031 inch (0.6~0.7 mm). This unit has electronic ignition, which requires no adjustments.

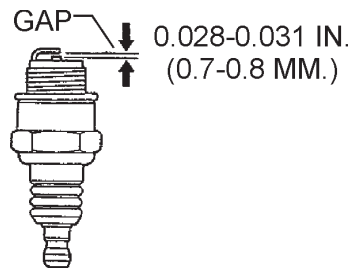

Figure 18. Spark Plug Gap

ENGINE OIL

- Drain the engine oil when the oil is **warm** as shown in Figure 19.
- Remove the oil drain bolt and sealing washer and allow the oil to drain into a suitable container.
- Replace engine oil with recommended type oil as listed in Table 5. Engine oil capacity is 1.16 quarts (1.1 liters). **DO NOT** overfill.
- Install drain bolt with sealing washer and tighten securely.

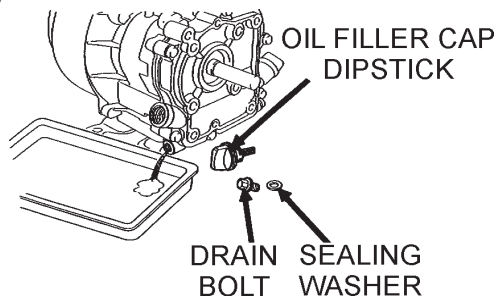
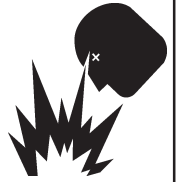

Figure 19. Engine Oil (Draining)

DANGER

DO NOT use gasoline as a cleaning solvent, because that would create a risk of fire or explosion.



ENGINE AIR CLEANER

- Remove the air cleaner cover and foam filter element as shown in Figure 20.
- Tap the paper filter element (Figure 20) several times on a hard surface to remove dirt, or blow compressed air [not exceeding 30 psi (207 kPa, 2.1 kgf/cm²)] through the filter element from the air cleaner case side. **NEVER** brush off dirt. Brushing will force dirt into the fibers. Replace the paper filter element if it is excessively dirty.
- Clean foam element in warm, soapy water or nonflammable solvent. Rinse and dry thoroughly. Dip the element in clean engine oil and completely squeeze out the excess oil from the element before installing.

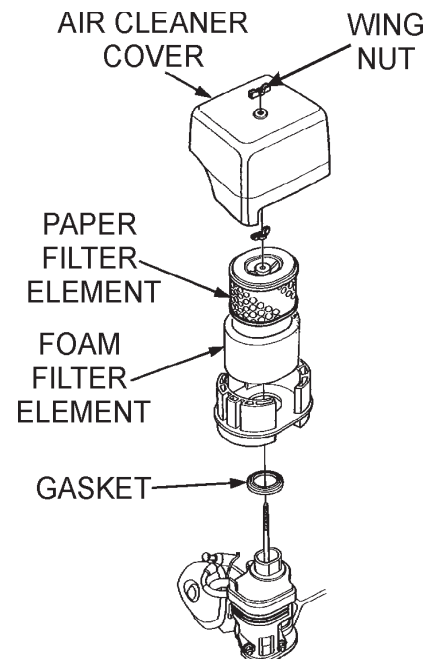

Figure 20. Engine Air Cleaner

Pump Storage

For storage of the pump for over 30 days, the following is required:

- Drain the fuel tank completely.
- Run the engine until the fuel in the injection system is completely consumed.
- Completely drain used oil from the engine crankcase and fill with fresh clean oil, then follow the procedures described in the engine manual for engine storage.
- Remove the drain plug from the pump and drain out any water from left in the housing.
- Remove the pump cover and clean inside of pump housing. Coat inside of pump housing with a light film of oil to reduce corrosion. A spray can of oil works well for this application.
- Cover suction and discharge ports with duct tape to prevent any foreign matter from falling into pump.
- Cover pump and engine with plastic covering or equivalent and store in a clean, dry place.
- To protect the water cooled-seals, place one-half pint of lubricating oil (new or used) through the discharge opening on the pump and crank the engine several times. This will prevent excessive corrosion and also keep the mechanical seal lubricated.

QP-205SH — TROUBLESHOOTING (ENGINE)

TABLE 7. ENGINE TROUBLESHOOTING

SYMPTOM	POSSIBLE PROBLEM	SOLUTION
Difficult to start		
Fuel is available but spark plug will not ignite. (Power available at high tension cable).	Ignition plug being bridge?	Check ignition system.
	Carbon deposit at ignition?	Clean or replace ignition.
	Short circuit due to defective insulators?	Replace insulators.
	Improper spark gap?	Set spark plug gap to the correct gap.
Fuel is available but spark plug will not ignite. (Power NOT available at high tension cable).	Short circuit at stop switch?	Check stop switch circuit. Replace stop switch if defective.
	Ignition coil defective?	Replace ignition coil.
Fuel is available and spark plug ignites (compression normal).	Muffler clogged with carbon deposits?	Clean or replace muffler.
	Mixed fuel quality is inadequate?	Check fuel to oil mixture.
	Fuel in use inadequate (water, dust)?	Flush fuel sytem and replace with fresh fuel.
	Air Cleaner clogged?	Clean or replace air cleaner.
Fuel is available and spark plug ignites (compression low).	Defective cylinder head gasket?	Tighten cylinder head bolts or replace head gasket.
	Cylinder worn?	Replace cylinder.
	Spark plug loose?	Tighen spark plug.
Operation not satisfactory		
Not enough power available (compression normal, no miss-firing).	Air cleaner clogged?	Clean or replace air cleaner.
	Air in fuel line?	Bleed (remove air) from fuel line.
	Fuel level in carbureator float chamber improper?	Adjust carbureator float
	Carbon deposits in cylinder?	Clean or replace cylinder
Not enough power available (compression normal, miss-firing).	Ignition coil defective?	Flush fuel sytem and replace with fresh fuel.
	Ignition plug often shorts?	Replace ignition wires, clean ignition.
	Fuel in use inadequate (water, dust)?	Flush fuel sytem and replace with fresh fuel.
Engine overheats.	Excessive carbon depostion in combustion chamber?	Clean or replace crankcase.
	Exhaust or muffler clogged with carbon.	Clean or replace muffler.
	Spark plug heat value incorrect?	Replace spark plug with correct type spark plug.

QP-205SH — TROUBLESHOOTING (ENGINE/PUMP)

TABLE 7. ENGINE TROUBLESHOOTING (Continued)

SYMPTOM	POSSIBLE PROBLEM	SOLUTION
Operation not satisfactory		
Rotational speed fluctuates.	Governor adjustment improper?	Adjust governor to correct lever.
	Governor spring defective?	Clean or replace ignition.
	Fuel flow erratic?	Check fuel line.
	Air taken in through suction line?	Check suction line.
Recoil starter not working properly.	Dust in rotating part?	Clean recoil starter assembly.
	Spring spring failure?	Replace sprial spring.

TABLE 8. PUMP TROUBLESHOOTING

SYMPTOM	POSSIBLE PROBLEM	SOLUTION
Pump does not take on water.	Not enough priming water in the housing?	Add water.
	Engine speed too low?	Increase throttle.
	Strainer plugged?	Clean strainer.
	Suction hose damaged?	Replace or repair hose, and clamps
	Air leak at suction port?	Check that fittings are tight and properly sealed.
	Pump is located too high above water line?	Move pump closer to water.
	Debris collecting in pump housing?	Clean pump housing.
	Water leaking out weep hole between pump and engine?	Check condition of mechanical seal and gaskets, between pump end and engine housing.
Pump takes in water, little or no discharge.	Engine speed too low?	Increase throttle speed.
	Suction strainer partially plugged?	Clean strainer.
	Impeller/Volute worn?	Adjust clearance by adding shims or replace impeller/volute
Suction hose leaks at inlet.	Fittings/clamps are not sealed properly?	Tighten, replace or add clamp. (Keep extra seals on pump)
	Hose diameter is too large?	Use smaller diameter hose or replace hose.
Discharge does not stay on coupling.	Pressure too high?	Check pressure, add additional clamp.
	Hose kinked or end blocked?	Check hose.
Impeller does not turn: pump is hard to start.	Impeller jammed or blocked?	Open pump cover and clean dirt and debris from inside housing.
	Impeller and volute binding?	Adjust clearance by removing shim from behind impeller.
	Defective engine?	See Engine Owner's Manual.

QP-205SH — EXPLANATION OF CODE IN REMARKS COLUMN

How to read the marks and remarks used in this parts book.

Items Found In the “Remarks” Column

Serial Numbers-Where indicated, this indicates a serial number range (inclusive) where a particular part is used.

Model Number-Where indicated, this shows that the corresponding part is utilized only with this specific model number or model number variant.

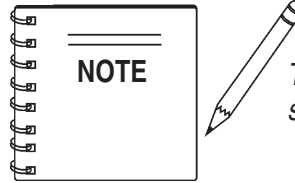

The contents of this catalog are subject to change without notice.

Items Found In the “Items Number” Column

All parts with same symbol in the number column, *, #, +, %, or <, belong to the same assembly or kit.

Note: If more than one of the same reference number is listed, the last one listed indicates newest (or latest) part available.

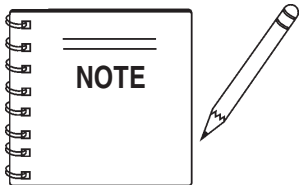

If more than one of the same reference number is listed, the last one listed indicates newest (or latest) part available.

QP-205SH CENTRIFUGAL PUMP 1 TO 3 UNITS WITH HONDA GX160K1TX2 ENGINE

Qty.	P/N	Description
2	KIT202TH	KIT, PUMP, MECHANICAL SEAL, O-RINGS
2	0631211100	DRAIN CAP, FLOODING
2	0480350300	O-RING FLOODING DRAIN CAP
1	0811582543	MECHANICAL SEAL SLEEVE
1	0480240160	O-RING, MECHANICAL SEAL SLEEVE
1	1841040030	IMPELLER
3	17210ZE1505	ELEMENT AIR CLEANER DUAL
3	9807956846	SPARK PLUG
1	17620ZH7023	CAP, FUEL WITH GASKET
1	28462ZH8003	ROPE STARTER

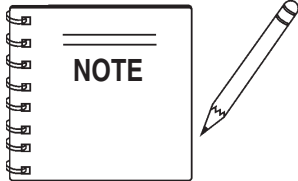

Part number on this Suggested Spare Parts List may super cede/replace the P/N shown in the text pages of this book.

QP-205SH — PUMP ASSY.

PUMP ASSY.

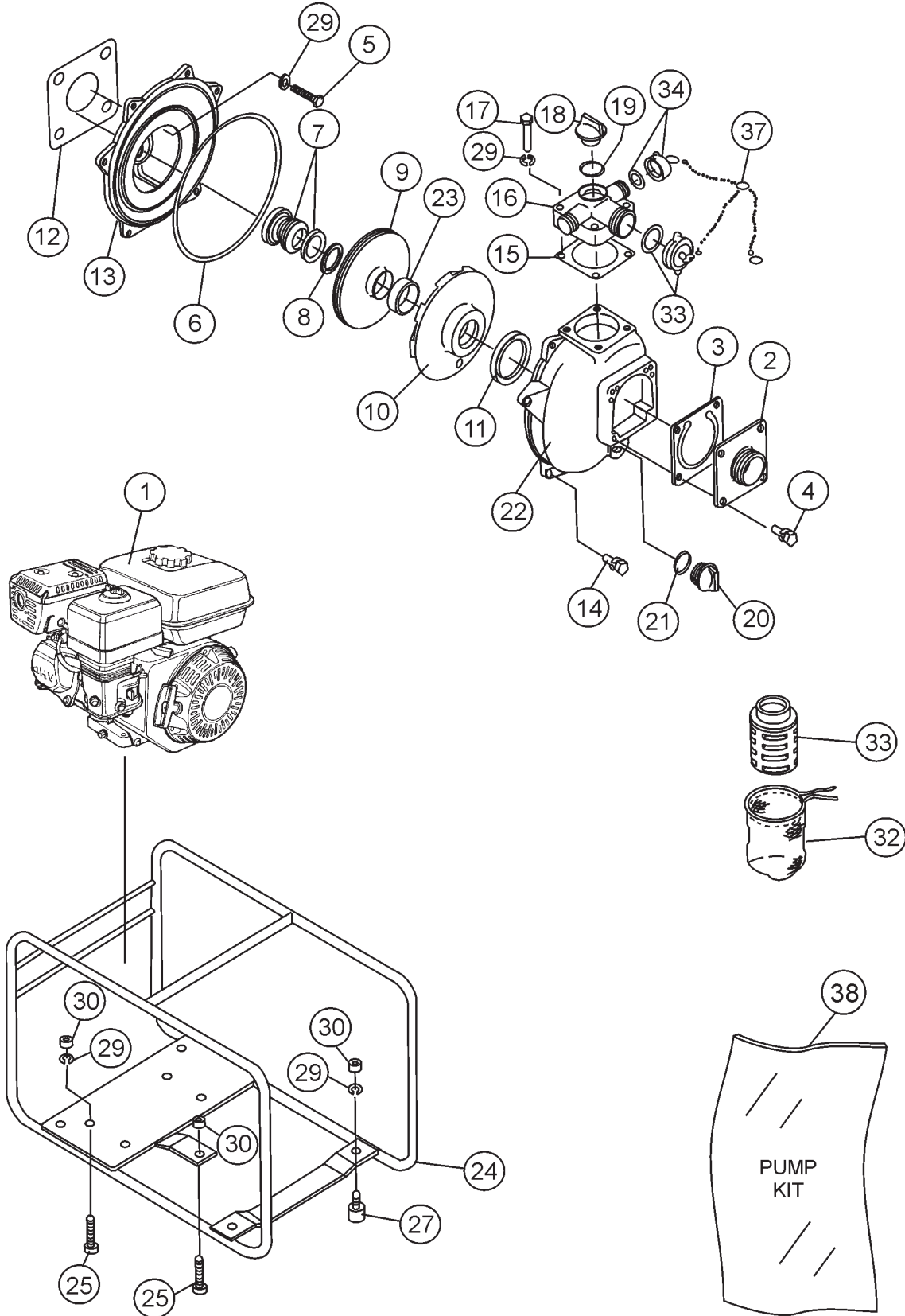

QP-205SH — PUMP ASSY.

PUMP ASSY.

<u>NO.</u>	<u>PART NO.</u>	<u>PART NAME</u>	<u>QTY.</u>	<u>REMARKS</u>
1	GX160K1TX2	ENGINE, HONDA	1	
2	1814100160	SUCTION COVER, NPT 2"	1	
3	1378350350	CHECK VALVE	1	
4	0181050825	BOLT SET WITH SPRING WASHER (SUCTION COVER), M8 X 25	4	
5	0181050825	BOLT SET WITH SPRING WASHER (CASING COVER), 5/16" X 24UNFx25	4	
6*	0489352550	O'RING (CASING), 3.5 X 255	1	
7*	0808112320	MECHANICAL SEAL, HJ MNL-12	1 SET	
8	0852831400	ADJUST LINER, 0.2 MM	1-3	REPLACES 0852821500
8	0852831400	ADJUST LINER, 0.3 MM	1-3	REPLACES 0852831500
8	0852851400	ADJUST LINER, 0.5 MM	1-3	REPLACES 0852851500
9	1814060030	IMPELLER, 5/8-18" UNF	1	
10	1803100130	VOLUTE CASING	1	
11*	1378330620	VOLUTE CASING PACKING	1	
12	1201390610	CASING COVER PACKING, 84 X 84	1	
13	9358100020	CASING COVER	1	
14	0181050825	BOLT SET WITH SPRING WASHER (CASING), M8 X 25	6	
15	1803330360	DELIVERY COVER PACKING	1	
16	1814100090	DELIVERY COVER (3 WAY OUTLET) NPT1" X NPT 1-1/2"	1	
17	0105050845	BOLT(DELIVERY CAP),M8 X 45	4	
18	0631211100	FLOODING CAP, PF 1"	1	
19	0480350300	O'RING (FLOODING CAP), P30	1	
20	0631211100	DRAIN CAP, PF 1"	1	
21	0480350300	O'RING (DRAIN CAP), P30	1	
22	1814100010	CASING	1	
23*	1803521220	LINER RING	1	
24	1823214010	BASE	1	
25	0105050845	BOLT (ENGINE), M8 X 40	4	
26	0105050820	BOLT SET WITH SPRING WASHER (PUMP), M8x20	1	
27	0723323040	CUSHION RUBBER, 40H30M8	4	
28	0401450080	WASHER M8	5	
29	0451250080	SPRING WASHER, M8	12	
30	0205450080	NUT (ENGINE CUSHION RUBBER)	9	
31	0742303050	STRAINER, NPT 2"	1	
32	0920312013	NYLON NET	1	
33	1806318050	CHAIN CAP (LARGE), NPS 1-1/2"	1	
34	1806318070	CHAIN CAP (SMALL), NPS1"	2	
35	0741310491	CHAIN CAP PACKING (LARGE 1-1/2")	1	
36	0741310321	CHAIN CAP PACKING (SMALL 1")	1	
37	1814209660	CHAIN	1	
38	KIT205	KIT, PUMP	1	INCLUDES ITEMS W/*

HONDA GX160K1TX2 ENGINE — AIR CLEANER (DUAL) ASSY.

AIR CLEANER (DUAL) ASSY.

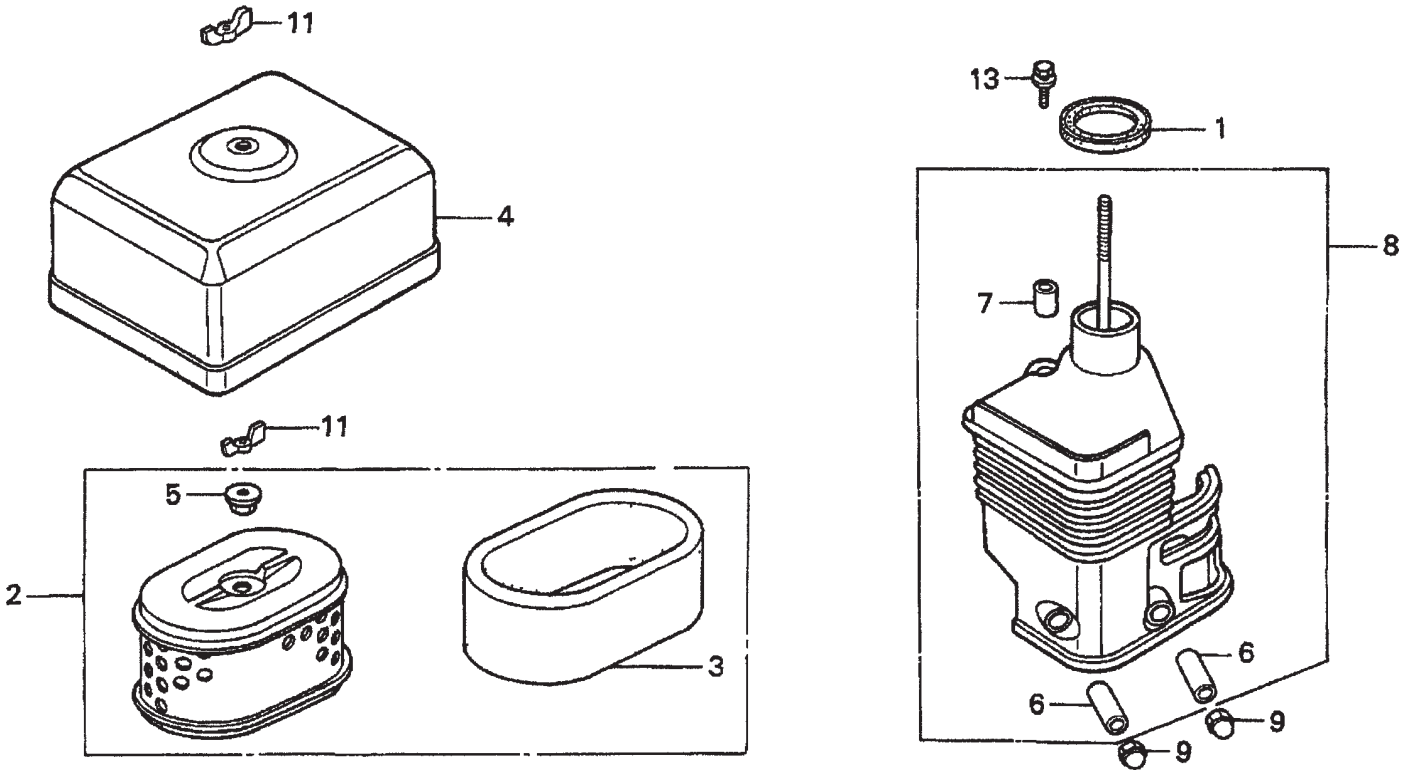

HONDA GX160K1TX2 ENGINE — AIR CLEANER (DUAL) ASSY.

AIR CLEANER (DUAL) ASSY.

<u>NO.</u>	<u>PART NO.</u>	<u>PART NAME</u>	<u>QTY.</u>	<u>REMARKS</u>
1	16271ZE1000	GASKET, ELBOW	1	
2	17210ZE1505	ELEMENT, AIR CLEANER (DUAL)	1	INCLUDES ITEMS W/*
3*	17218ZE1505	FILTER (OUTER)	1	
4	17230ZE1820	COVER, AIR CLEANER (DUAL)	1	
5*	17232891000	GRO mmET, AIR CLEANER	1	
6#	17238ZE7010	COLLAR, AIR CLEANER	2	
7#	17239ZE1000	COLLAR B, AIR CLEANER	1	
8	17410ZE1020	ELBOW, AIR CLEANER	1	INCLUDES ITEMS W/#
9	90201415000	NUT, CAP (6 mm)	2	
11	90325044000	WINGNUT, TOOL BOX SETTING	1	
12	90325044000	WINGNUT, TOOL BOX SETTING	1	
13	957010602000	BOLT, FLANGE (6 X 20)	1	

HONDA GX160K1TX2 ENGINE — CAMSHAFT ASSY.

CAMSHAFT ASSY.

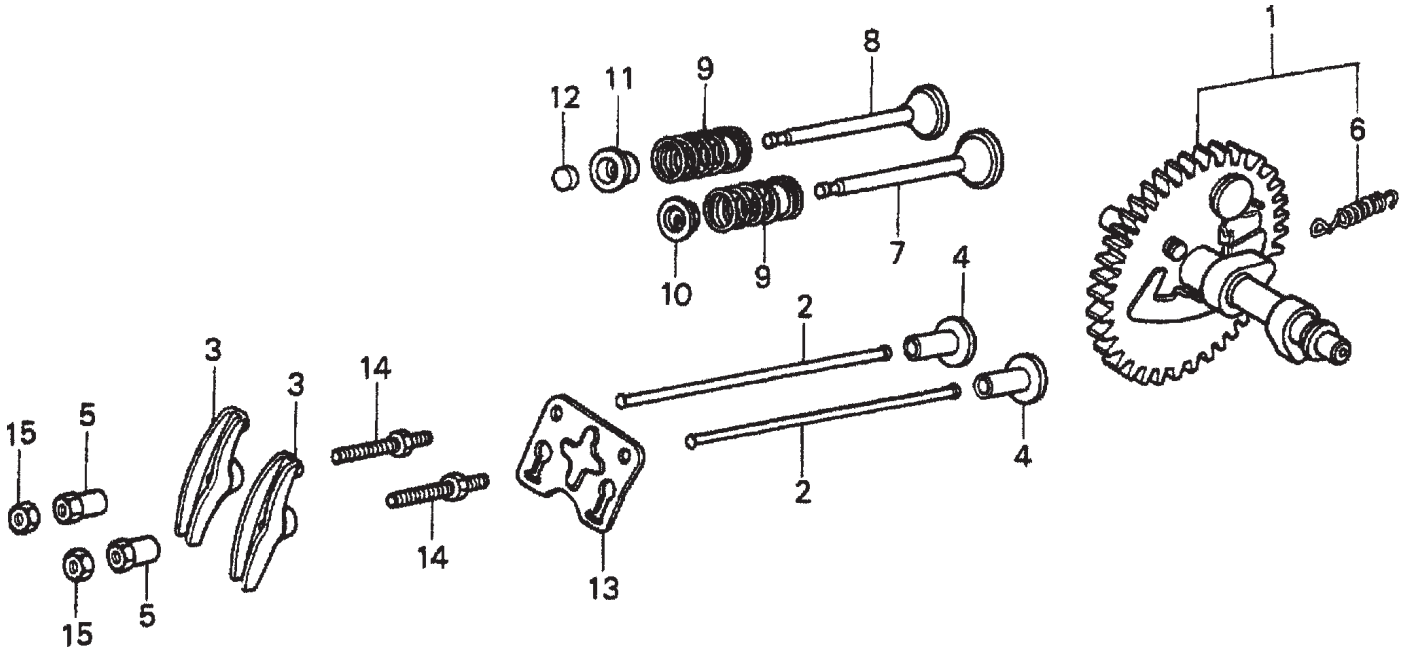

HONDA GX160K1TX2 ENGINE — CAMSHAFT ASSY.

CAMSHAFT ASSY.

<u>NO.</u>	<u>PART NO.</u>	<u>PART NAME</u>	<u>QTY.</u>	<u>REMARKS</u>
1	14100ZE1812	CAMSHAFT ASSY.	1	INCLUDES ITEMS W/*
2	14410ZE1010	ROD, PUSH	2	
3	14431ZE1000	ARM, VLAVE ROCKER	2	
4	14441ZE1010	LIFTER, VALVE	2	
5	14451ZE1013	PIVOT, ROCKER ARM	2	
6*	14568ZE1000	SPRING, WEIGHT RETURN	1	
7	14711ZF1000	VALVE, IN.	1	
8	14721ZH8810	VALVE, EX. (STELITE)	1	
9	14751ZF1000	SPRING VALVE	2	
10	14771ZE1000	RETAINER, IN. VALVE SPRING	1	
11	14773ZE1000	RETAINER, EX. VALVE SPRING	1	
12	14781ZE1000	ROTATOR, VALVE	1	
13	14791ZE1010	PLATE, PUSH ROD GUIDE	1	
14	90012ZE0010	BOLT, PIVOT (8 mm)	2	
15	90206ZE1000	NUT, PIVOT ADJ.	2	

HONDA GX160K1TX2 ENGINE — CARBURETOR ASSY.

CARBURETOR ASSY.

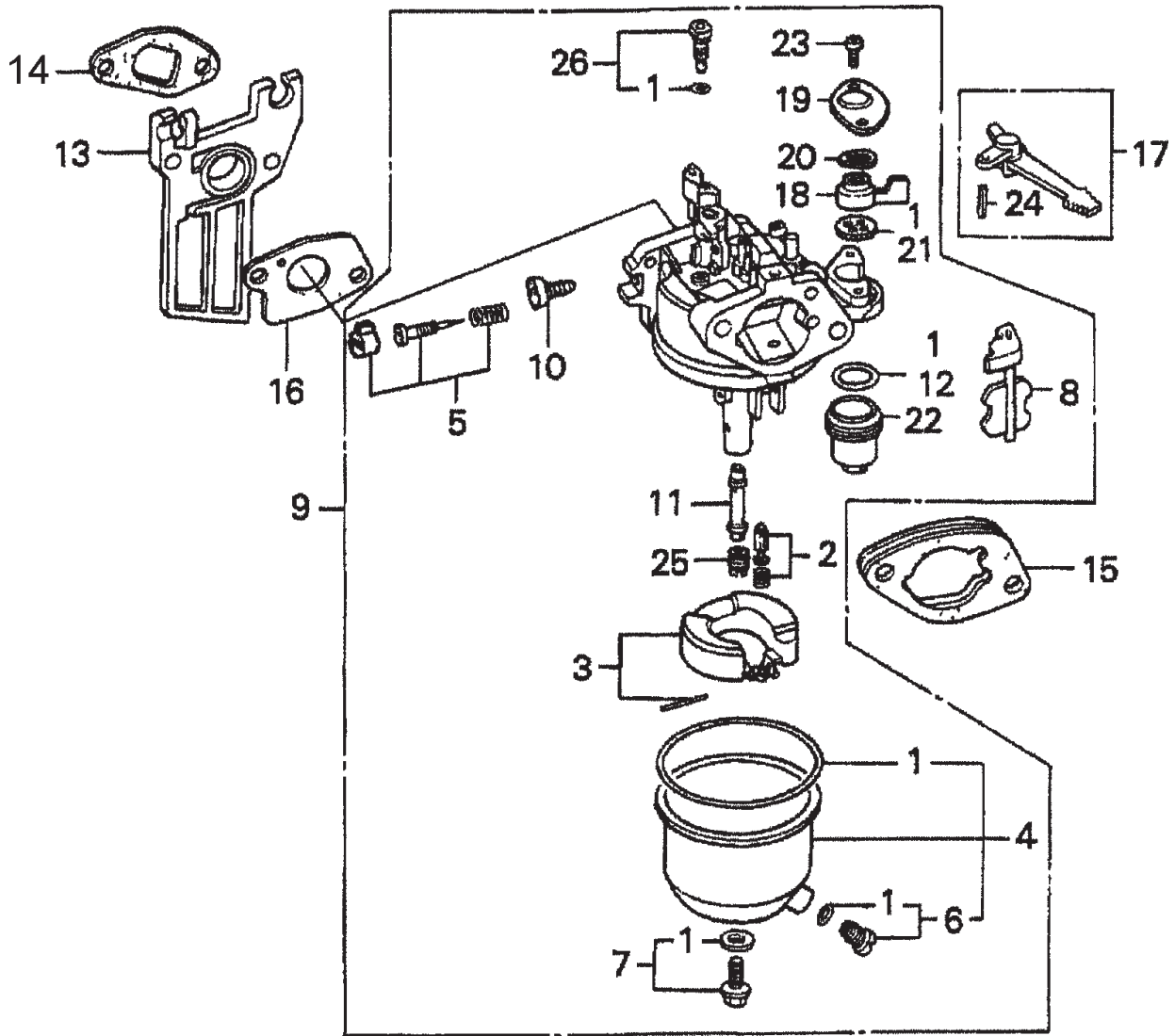

HONDA GX160K1TX2 ENGINE — CARBURETOR ASSY.

CARBURETOR ASSY.

<u>NO.</u>	<u>PART NO.</u>	<u>PART NAME</u>	<u>QTY.</u>	<u>REMARKS</u>
1*	16010ZE1812	GASKET SET	1	
2*	16011ZE0005	VALVE SET, FLOAT	1	
3*	16013ZE0005	FLOAT SET	1	
4*	16015ZE0831	CHAMBER SET, FLOAT	1	
4*	16015ZE1811	CHAMBER SET, FLOAT	1 USE UP TO ENGINE S/N BE65B A
5*	16016ZH7W01	SCREW SET	1	
6*	16024ZE1811	SCREW SET, DRAIN	1	
7*	16028ZE0005	SCREW SET B	1	
8*	16044ZE0005	CHOKE SET	1	
9	16100ZH8W51	CARBURETOR ASSY. (BE65B B)	1 INCLUDES ITEMS W/*
10*	16124ZE0005	SCREW, THROTTLE STOP	1	
11*	16166ZH8W50	NOZZLE, MAIN	1	
12*	16173001004	O-RING	1	
13	16211ZE1000	INSULATOR, CARBURETOR	1	
14	16212ZH8800	GASKET, INSULATOR	1	
15	16220ZE1020	SPACER, CARBURETOR	1	
16	16221ZH8801	GASKET, CARBURETOR	1	
17	16610ZE1000	LEVER, CHOKE (STD)	1 INCLUDES ITEMS W/#
18*	16953ZE1812	LEVER, VALVE	1	
19*	16954ZE1811	PLATE, LEVER SETTING	1	
20*	16956ZE1811	SPRING, VALVE LEVER	1	
21*	16957ZE1812	GASKET, VALVE	1	
22*	16967ZE0811	CUP, FUEL STRAINER	1	
23*	93500030060H	SCREW, PAN (3 X 6)	2	
24#	9430520122	PIN, SPRING (2 X 12)	1	
25	99101ZH80650	JET, MAIN (#65)	1 OPTIONAL
25	99101ZH80680	JET, MAIN (#68)	1 OPTIONAL
25*	99101ZH80700	JET, MAIN (#70)	1	
26*	99204ZE00350	JET, SET, PILOT (#35)	1	

HONDA GX160K1TX2 ENGINE — CONTROL ASSY.

CONTROL ASSY.

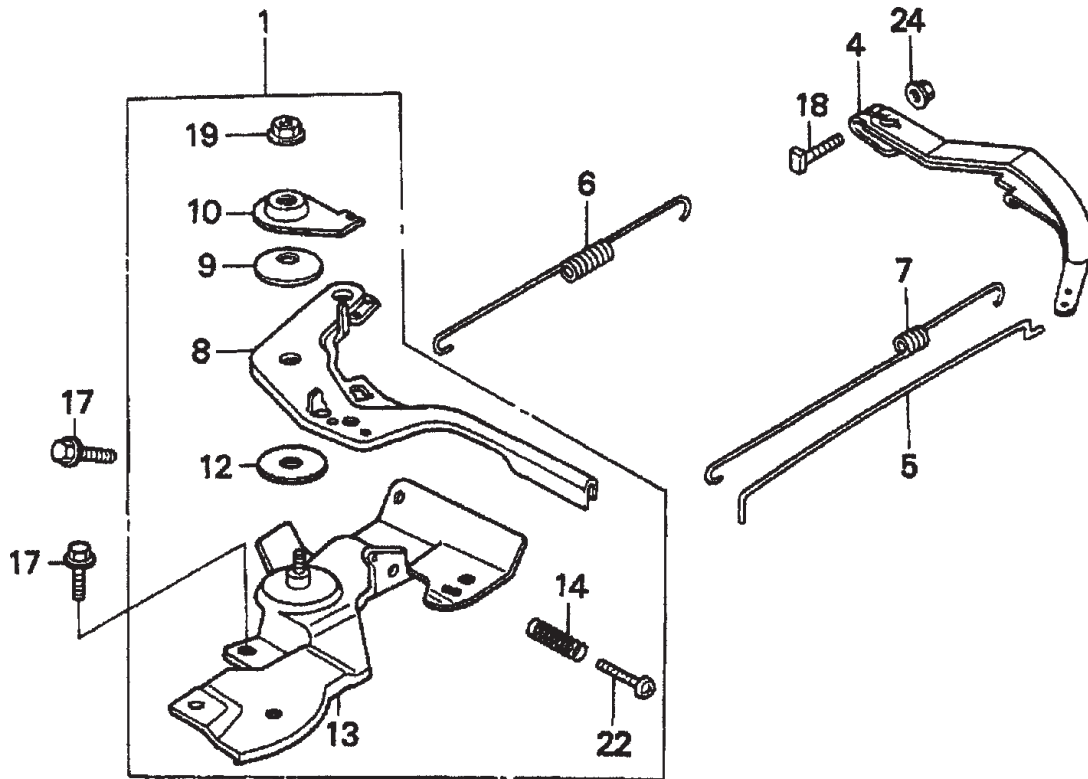

HONDA GX160K1TX2 ENGINE — CONTROL ASSY.

CONTROL ASSY.

<u>NO.</u>	<u>PART NO.</u>	<u>PART NAME</u>	<u>QTY.</u>	<u>REMARKS</u>
1	16500ZH8030	CONTROL ASSY.	1 INCLUDES ITEMS W/*
4	16551ZE0010	ARM, GOVERNOR	1	
5	16555ZE1000	ROD, GOVERNOR	1	
6	16561ZE1020	SPRING, GOVERNOR	1	
7	16562ZE1020	SPRING, THROTTLE RETURN	1	
8*	16571ZH8020	LEVER, CONTROL	1	
9*	16574ZE1000	SPRING, LEVER	1	
10*	16575ZH8000	WASHER, CONTROL LEVER	1	
12*	16578ZE1000	SPACER, CONTROL LEVER	1	
13*	16580ZH8030	BASE, CONTROL	1	
14*	16584883300	SPRING, CONTROL ADJUSTING	1	
17	90013883000	BOLT, FLANGE (6 X 12) (CT200)	2	
18	90015ZE5010	BOLT, GOVERNOR ARM	1	
19*	90114SA0000	NUT, SELF-LOCK (6 mm)	1	
22*	93500050250A	SCREW, PAN (5 X 25)	1	
24	9405006000	NUT, FLANGE (6 mm)	1	

HONDA GX160K1TX2 ENGINE — CRANKCASE COVER ASSY.

CRANKCASE COVER ASSY.

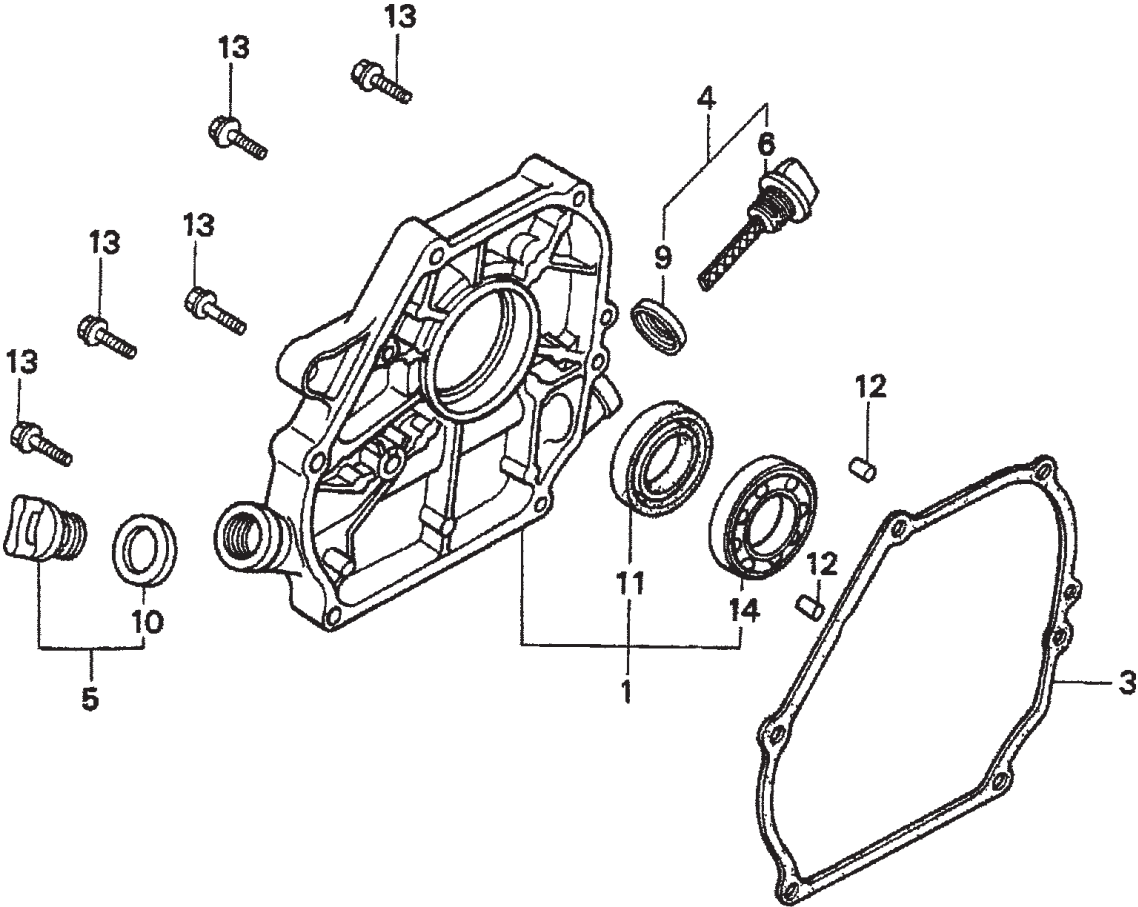

HONDA GX160K1TX2 ENGINE — CRANKCASE COVER ASSY.

CRANKCASE COVER ASSY.

<u>NO.</u>	<u>PART NO.</u>	<u>PART NAME</u>	<u>QTY.</u>	<u>REMARKS</u>
1	11300ZE1641	COVER ASSY., CRANKCASE (U-TYPE)	1	INCLUDES ITEMS W/*
3	11381ZH8801	GASKET, CASE COVER	1	
4	15600ZE1003	CAP ASSY., OIL FILLER	1	INCLUDES ITEMS W/#
5	15600ZG4003	CAP ASSY., OIL FILLER	1	INCLUDES ITEMS W/+
6#	15620ZE1003	CAP, OIL FILLER		
9#	15625ZE1003	GASKET, OIL FILLER CAP	1	
10+	15625ZE1003	GASKET, OIL FILLER CAP	1	
11*	91202883005	OIL SEAL (25 X 41 X 6)	1	
12	9430108140	PIN A, DOWEL (8 X 14)	2	
13	957010803200	BOLT, FLANGE (8 X 32)	6	
14*	961006205000	BEARING, RADIAL BALL (6205)	1	

HONDA GX160K1TX2 ENGINE — CRANKSHAFT ASSY.

CRANKSHAFT ASSY.

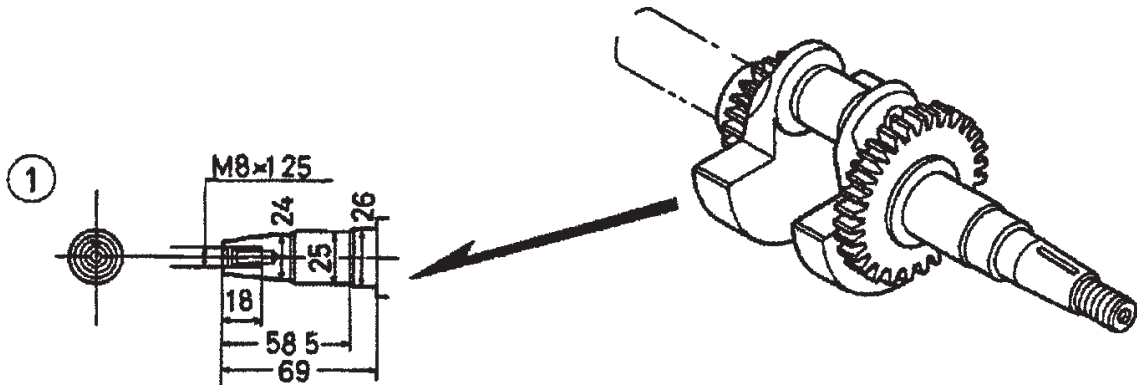

HONDA GX160K1TX2 ENGINE — CRANKSHAFT ASSY.

CRANKSHAFT ASSY.

<u>NO.</u>	<u>PART NO.</u>	<u>PART NAME</u>	<u>QTY.</u>	<u>REMARKS</u>
1	13310ZE1660	CRANKSHAFT (T-TYPE)	1	

HONDA GX160K1TX2 ENGINE — CYLINDER BARREL ASSY.

CYLINDER BARREL ASSY.

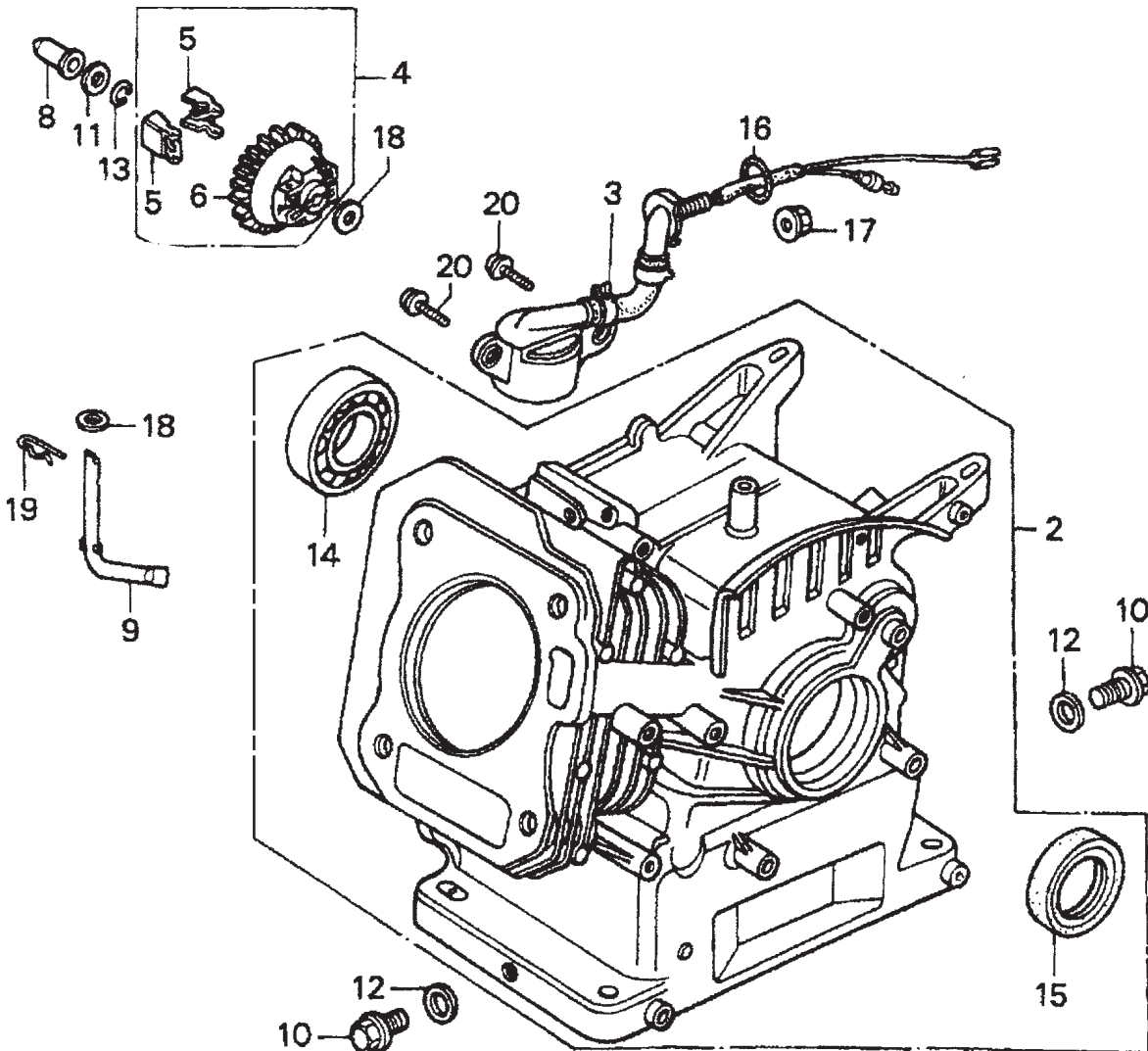

HONDA GX160K1TX2 ENGINE — CYLINDER BARREL ASSY.

CYLINDER BARREL ASSY.

NO.	PART NO.	PART NAME	QTY.	REMARKS
2	12000ZH8811	CYLINDER ASSY. (OIL ALERT)	1	INCLUDES ITEMS W/*
3	15510ZE1033	SWITCH ASSY., OIL LEVEL	1	
4	16510ZE1000	GOVERNOR ASSY.	1	INCLUDES ITEMS W/#
5#	16511ZE1000	WEIGHT, GOVERNOR	2	
6#	16512ZE1000	HOLDER, GOVERNOR WEIGHT	1	
8	16531ZE1000	SLIDER, GOVERNOR	1	
9	16541ZE1000	SHAFT, GOVERNOR ARM	1	
10	90131ZE1000	BOLT, DRAIN PLUG	2	
11	90451ZE1000	WASHER, THRUST (6 mm)	1	
12	90601ZE1000	WASHER, DRAIN PLUG (10.2 mm)	2	
13	90602ZE1000	CLIP, GOVERNOR HOLDER	1	
14*	91001ZF1003	BEARING, RADIAL BALL (6205)	1	
15*	91202883005	OIL SEAL (25 X 41 X 6)	1	
16	91353671003	O-RING (13.5 X 1.5) (ARAI)	1	
17	9405010000	NUT, FLANGE (10 mm)	1	
18	9410106800	WASHER, PLAIN (6 mm)	2	
19	9425108000	PIN, LOCK (8 mm)	1	
20	957010601200	BOLT, FLANGE (6 X 12)	2	

HONDA GX160K1TX2 ENGINE — CYLINDER HEAD ASSY.

CYLINDER HEAD ASSY.

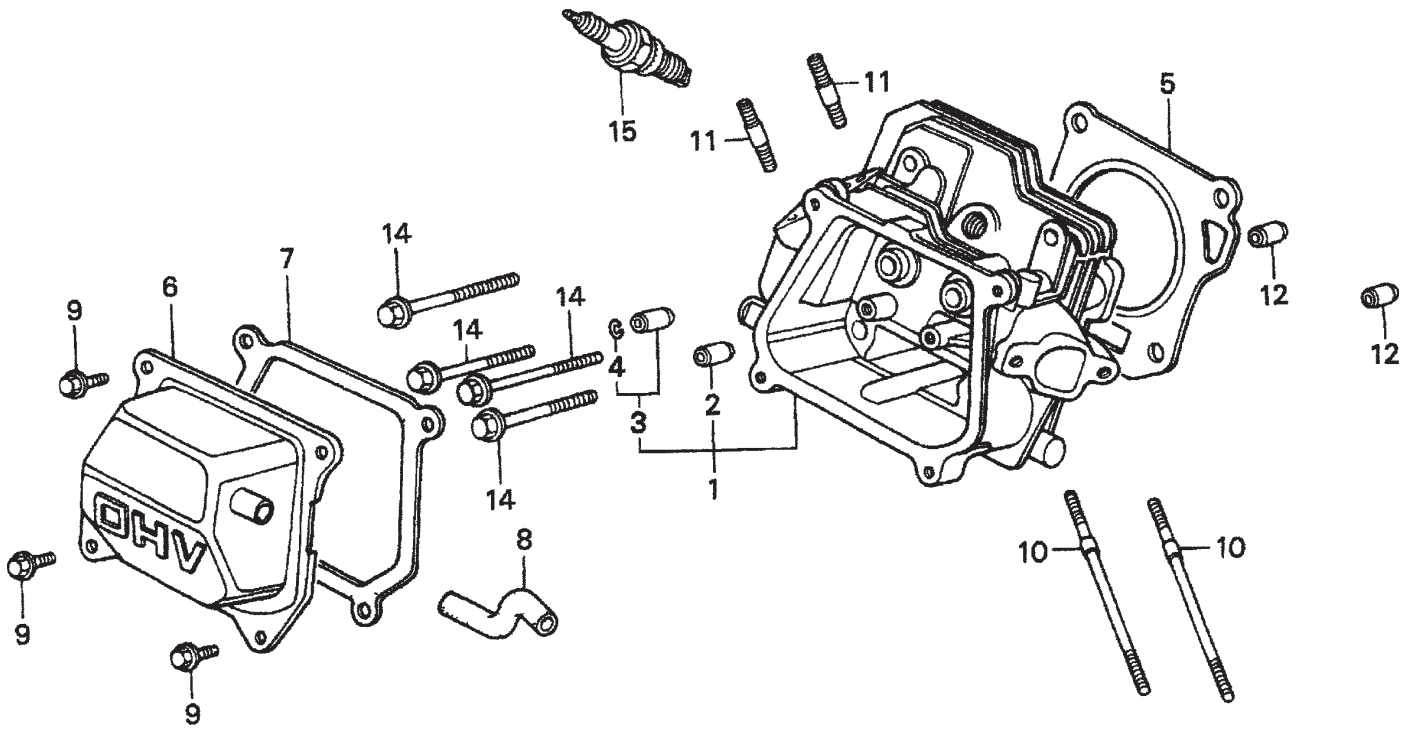

HONDA GX160K1TX2 ENGINE — CYLINDER HEAD ASSY.

CYLINDER HEAD ASSY.

<u>NO.</u>	<u>PART NO.</u>	<u>PART NAME</u>	<u>QTY.</u>	<u>REMARKS</u>
1	12210ZH8000	CYLINDER HEAD	1	INCLUDES ITEMS W/*
2*	12204ZE1306	GUIDE, VALVE (OS) (OPTIONAL)	1	
3*	12205ZE1315	GUIDE, EX. VALVE (OS) (OPTIONAL)	1	
4*	12216ZE5300	CLIP, VALVE GUIDE	1	
5	12251ZF1800	GASKET, CYLINDER HEAD	1	
6	12310ZE1010	COVER, HEAD	1	
7	12391ZE1000	GASKET, CYLINDER HEAD COVER	1	
8	15721ZH8000	TUBE, BREATHER	1	
9	90016ZE1000	BOLT, FLANGE (6 X 13)	4	
10	90043ZE1020	BOLT, STUD (6 X 109)	2	
11	90047ZE1000	BOLT, STUD (8 X 32)	2	
12	9430110160	PIN A, DOWELL (10 X 16)	2	
14	957230806000	BOLT, FLANGE (8 X 60)	4	
15	9807955846	SPARK PLUG (BPR5ES) (NGK)	1	
15	9807956846	SPARK PLUG (BPR6ES) (NGK)	1	

HONDA GX160K1TX2 ENGINE — FAN COVER ASSY.

FAN COVER ASSY.

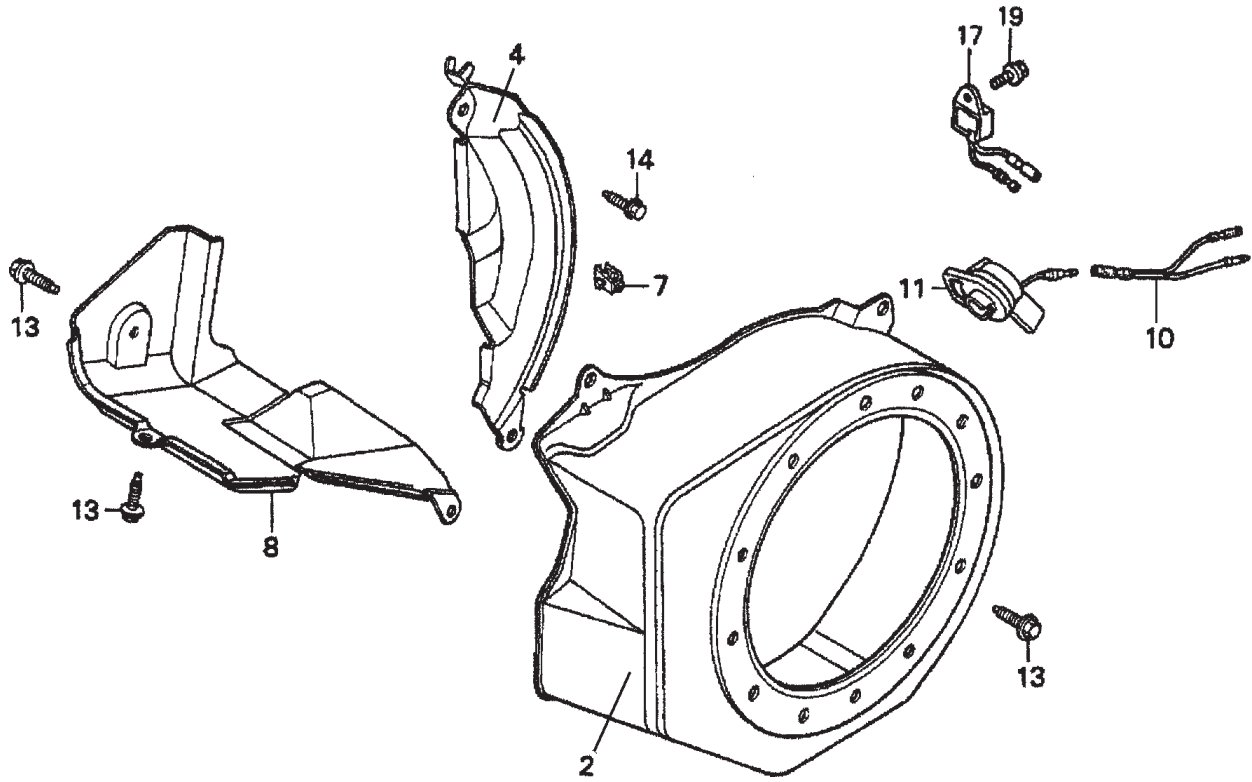

HONDA GX160K1TX2 ENGINE — FAN COVER ASSY.

FAN COVER ASSY.

<u>NO.</u>	<u>PART NO.</u>	<u>PART NAME</u>	<u>QTY.</u>	<u>REMARKS</u>
2	19610ZE1000ZC	COVER, FAN *NH1* (BLACK)	1	
4	19612ZH8810	PLATE, SIDE (OIL ALERT)	1	USE FROM ENGINE S/N 5372719
4	19612ZH8811	PLATE, SIDE (OIL ALERT)	1	USE FROM ENGINE
			S/N 4795906 TO 5066322
7	90601ZH7013	CLIP, HARNESS	1	
8	19630ZH8000	SHROUD	1	
10	32197ZH8003	SUB-HARNESS	1	USE UP TO ENGINE S/N 4367320
11	36100ZE1015	SWITCH ASSY., ENGINE STOP	1	
13	90013883000	BOLT, FLANGE (6 X 12) (CT200)	6	
14	90022888010	BOLT, FLANGE (6 X 20) (CT200)	1	
17	34150ZH7003	ALERT UNIT, OIL	1	
19	957010600800	BOLT, FLANGE (6 X 8)	1	

HONDA GX160K1TX2 ENGINE — FLYWHEEL ASSY.

FLYWHEEL ASSY.

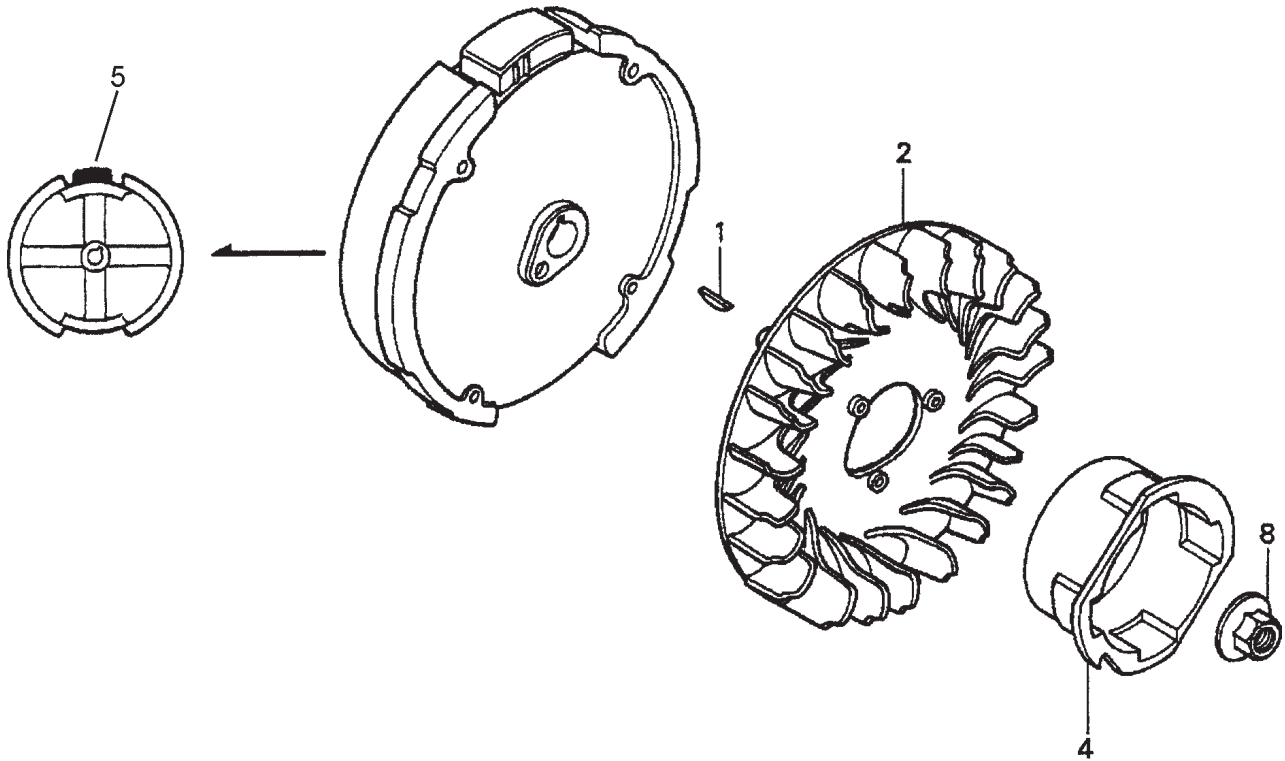

HONDA GX160K1TX2 ENGINE — FLYWHEEL ASSY.

FLYWHEEL ASSY.

<u>NO.</u>	<u>PART NO.</u>	<u>PART NAME</u>	<u>QTY.</u>	<u>REMARKS</u>
1	13331357000	KEY, SPECIAL WOODRUFF (25 X 18)	1	
2	19511ZE1000	FAN, COOLING	1	
4	28451ZH8003	PULLEY, STARTER	1	
5	31100ZE1010	FLYWHEEL	1	
5	31100ZE1810	FLYWHEEL (LAMP)	1	
8	90201878003	NUT, SPECIAL (14 mm)	1	

HONDA GX160K1TX2 ENGINE — FUEL TANK ASSY.

FUEL TANK ASSY.

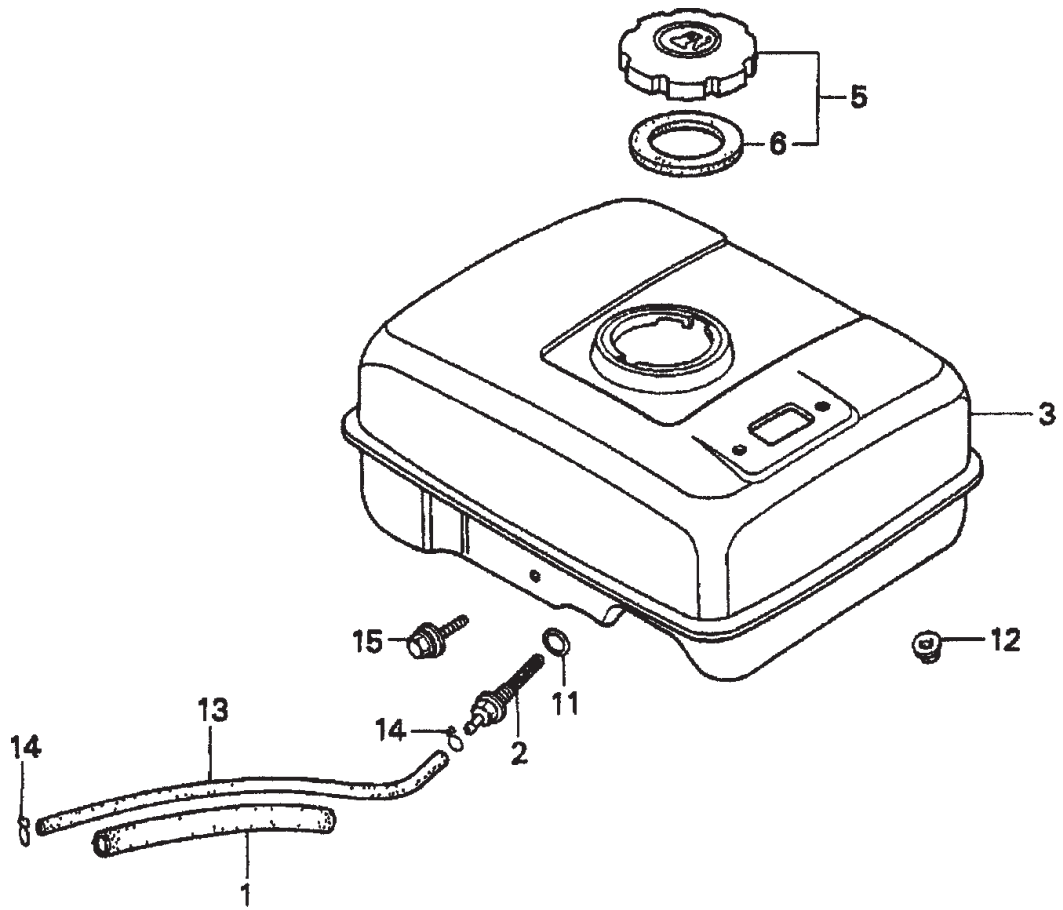

HONDA GX160K1TX2 ENGINE — FUEL TANK ASSY.

FUEL TANK ASSY.

<u>NO.</u>	<u>PART NO.</u>	<u>PART NAME</u>	<u>QTY.</u>	<u>REMARKS</u>
1	16854ZH8000	RUBBER, SUPPORTER (107 mm)	1	
2	16955ZE1000	JOINT, FUEL TANK	1	
3	17510ZE1020ZF	TANK, FUEL *NH1* (BLACK)	1	
5	17620ZH7023	CAP, FUEL FILLER	1	INCLUDES ITEMS W/*
6*	17631ZH7003	GASKET, FUEL FILLER CAP	1	
11	91353671003	O-RING (13.5 X 1.5) (ARAI)	1	
12	9405006000	NUT, FLANGE (6 mm)	2	
13	950014500360M	BULK HOSE, FUEL (4.5 X 3000) (4.5 X 140)	1	
14	9500202080	CLIP, TUBE (B8)	2	
15	957010602500	BOLT, FLANGE (6 X 25)	1	

HONDA GX160K1TX2 ENGINE — IGNITION COIL ASSY.

IGNITION COIL ASSY.

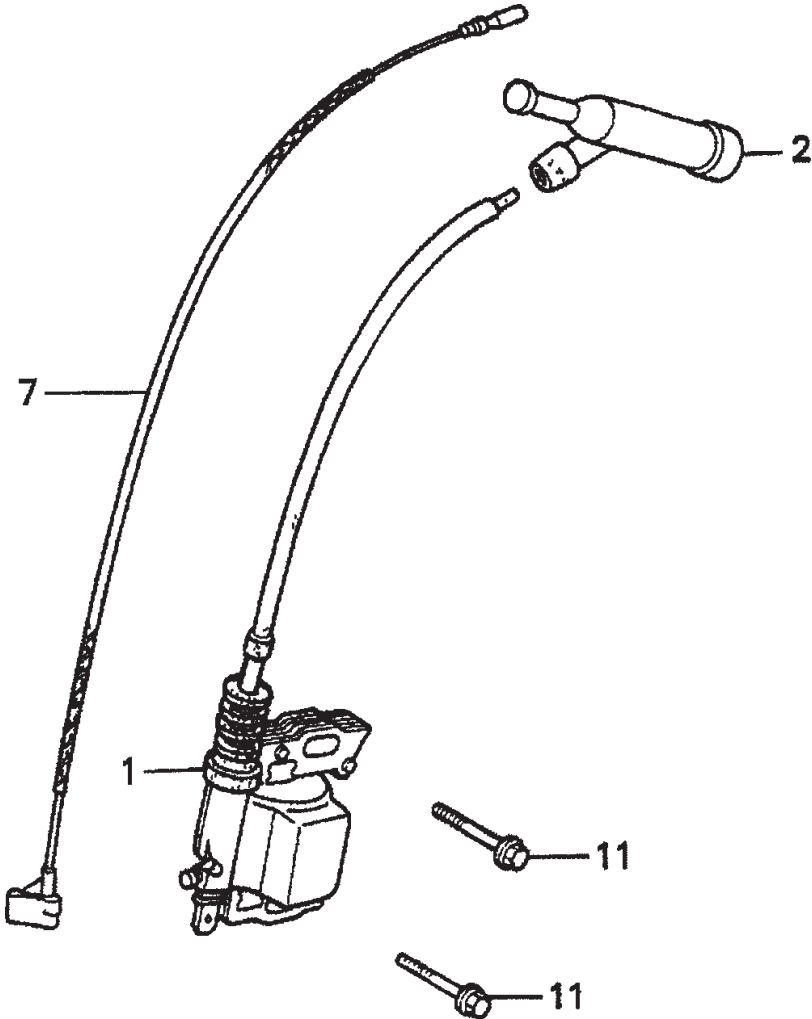

HONDA GX160K1TX2 ENGINE — IGNITION COIL ASSY.

IGNITION COIL ASSY.

<u>NO.</u>	<u>PART NO.</u>	<u>PART NAME</u>	<u>QTY.</u>	<u>REMARKS</u>
1	30500ZE1033	COIL ASSY., IGNITION	1	
2	30700ZE1013	CAP ASSY., NOISE SUPPRESSOR	1	
7	36101ZE1010	WIRE, STOP SWITCH (370 mm)	1	
11	90121952000	BOLT, FLANGE (6 X 25)	2	

HONDA GX160K1TX2 ENGINE — MUFFLER ASSY.

MUFFLER ASSY.

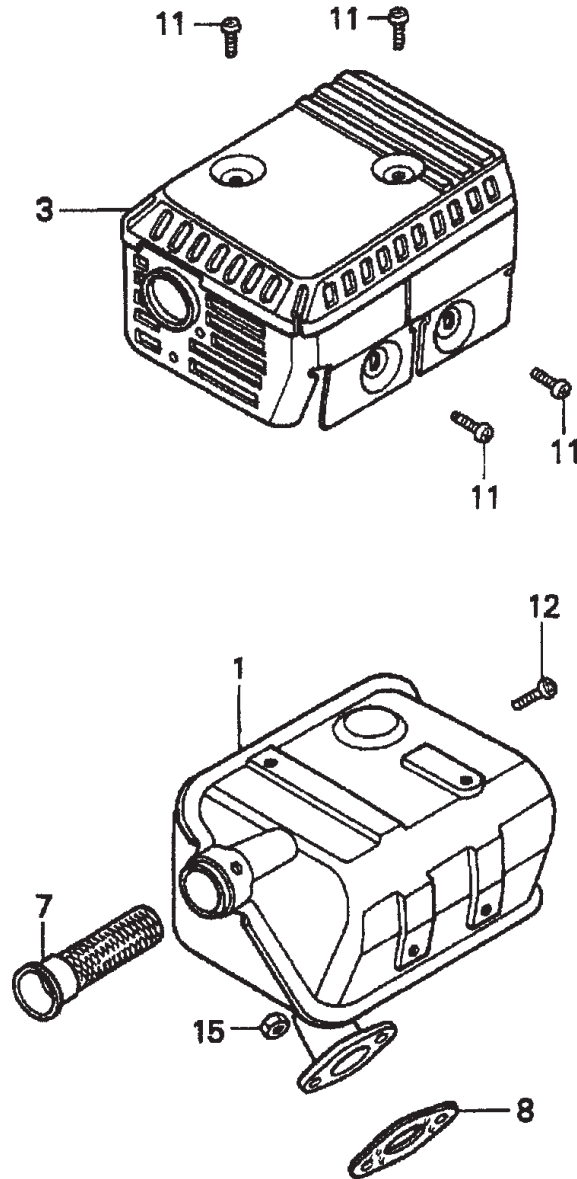

HONDA GX160K1TX2 ENGINE — MUFFLER ASSY.

MUFFLER ASSY.

<u>NO.</u>	<u>PART NO.</u>	<u>PART NAME</u>	<u>QTY.</u>	<u>REMARKS</u>
1	18310ZF1000	MUFFLER	1	
1	18310ZH8810	MUFFLER (OPTIONAL)	1	
3	18320ZF1H01	PROTECTOR, MUFFLER	1	
7	18355ZE1000	ARRESTER, SPARK (OPTIONAL)	1	
8	18381ZH8800	GASKET, MUFFLER	1	
11	90050ZE1000	SCREW, TAPPING (5 X 8)	4	
12	90055ZE1000	SCREW, TAPPING (4 X 6) (OPTIONAL)	1	
15	94001080000S	NUT, HEX (8 mm)	2	

HONDA GX160K1TX2 ENGINE — PISTON ASSY.

PISTON ASSY.

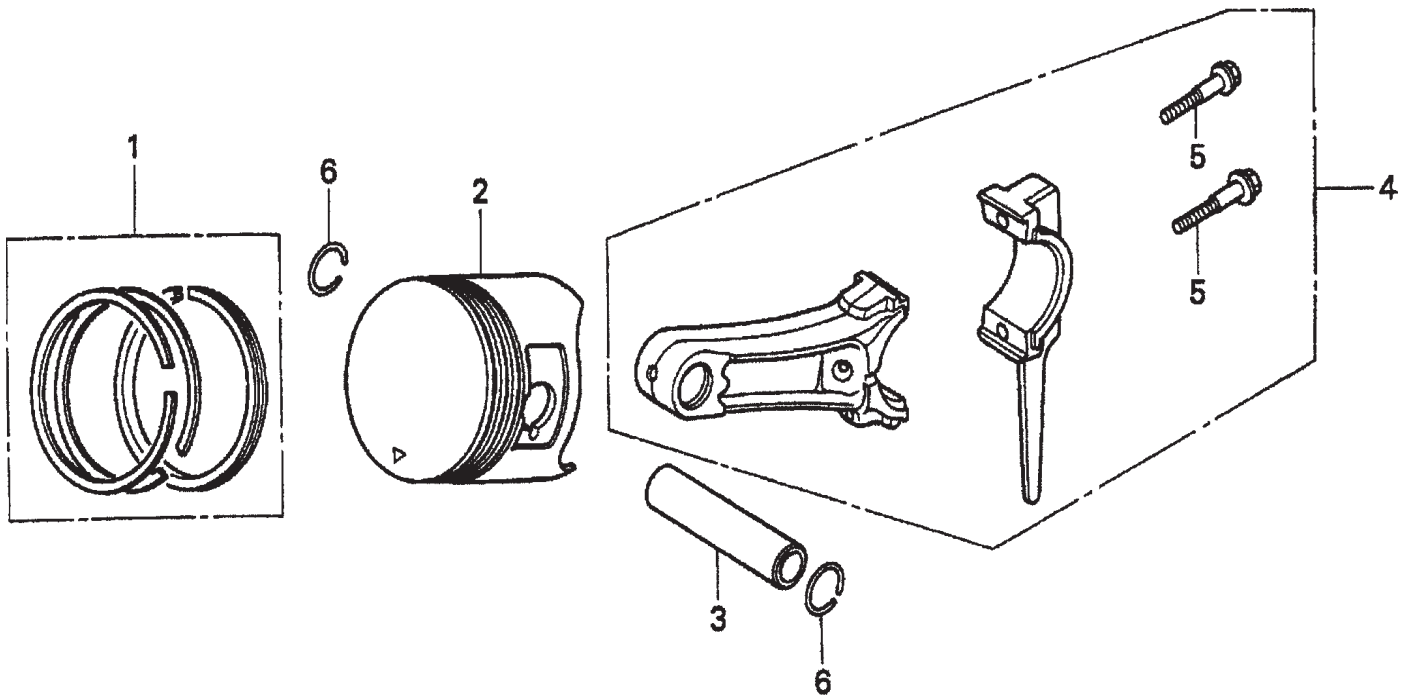

HONDA GX160K1TX2 ENGINE — PISTON ASSY.

PISTON + RINGS ASSY.

<u>NO.</u>	<u>PART NO.</u>	<u>PART NAME</u>	<u>QTY.</u>	<u>REMARKS</u>
1	13010ZF1023	RING SET, PISTON (STD)	1	USE UP TO ENGINE S/N 4733210
1	13010ZH8941	RING SET, PISTON (STD)	1	USE FROM ENGINE S/N 4733211
1	13011ZF1023	RING SET, PISTON (OS 0.25)	1	USE UP TO ENGINE S/N 4733210
1	13011ZH8941	RING SET, PISTON (OS 0.25)	1	USE FROM ENGINE S/N 4733211
1	13012ZF1023	RING SET, PISTON (OS 0.50)	1	USE UP TO ENGINE S/N 4733210
1	13012ZH8941	RING SET, PISTON (OS 0.50)	1	USE FROM ENGINE S/N 4733211
1	13013ZF1023	RING SET, PISTON (0.75) OPTION	1	USE UP TO ENGINE S/N 5495899
1	13013ZH8941	RING SET, PISTON (0.75) OPTION	1	USE FROM ENGINE S/N 5495900
2	13101ZH8000	PISTON (STD)	1	
2	13102ZH8000	PISTON (OS 0.25)	1	
2	13103ZH8000	PISTON (OS 0.50)	1	
2	13104ZH8000	PISTON (0.75)	1	
3	13111ZE1000	PIN, PISTON	1	
4	132A0ZE1000	ROD ASSY., CONNECTING (US 0.25)	1	INCLUDES ITEMS W/*
4	13200ZE1000	ROD ASSY., CONNECTING	1	USE UP TO ENGINE S/N 3427585
4	13200ZE1010	ROD ASSY., CONNECTING	1	USE FROM ENGINE S/N 3427586
5*	90001ZE1000	BOLT, CONNECTING ROD	2	
6	90551ZE1000	CLIP, PISTON PIN (18 mm)	2	

HONDA GX160K1TX2 ENGINE — RECOIL STARTER ASSY.

RECOIL STARTER ASSY.

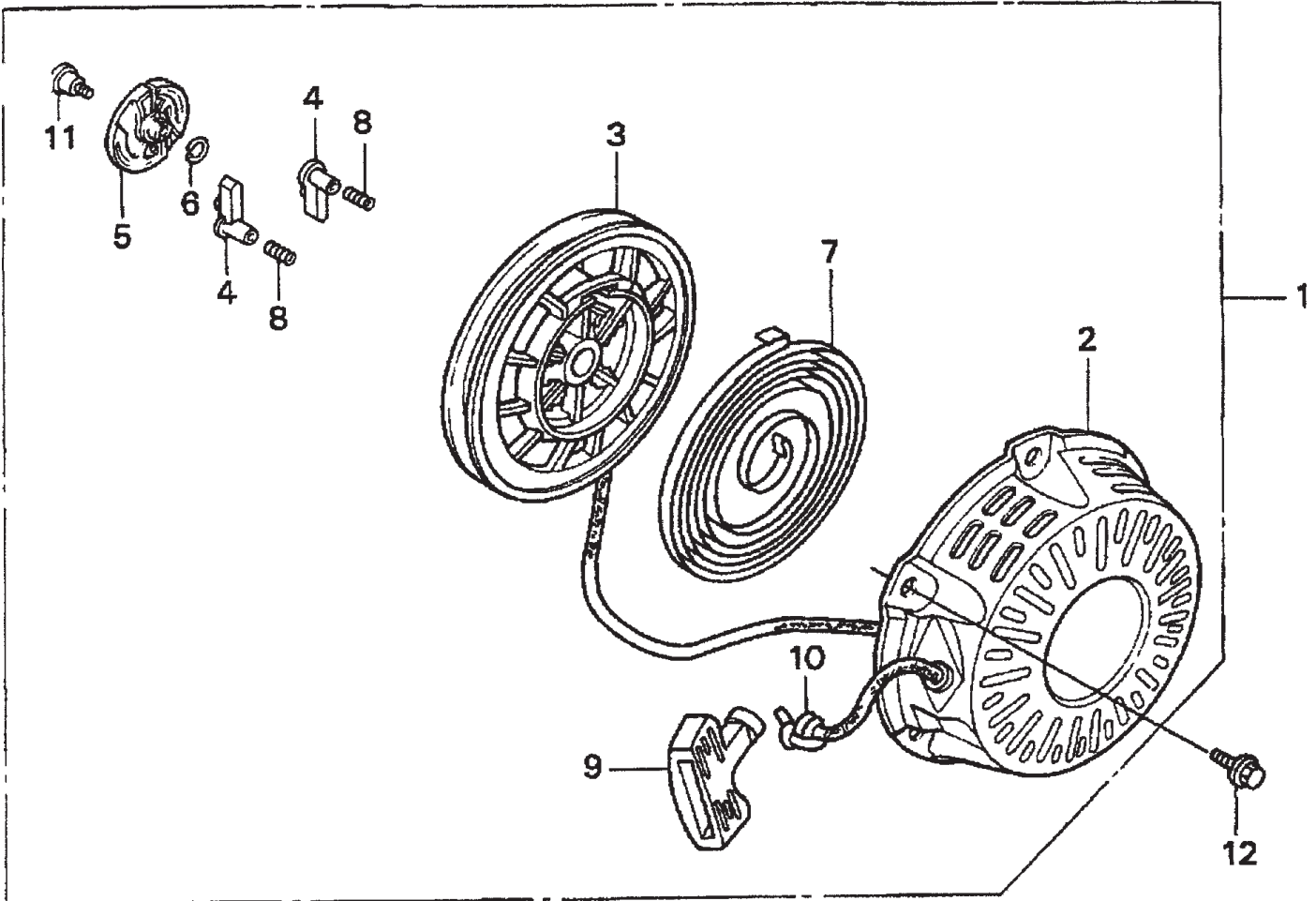

HONDA GX160K1TX2 ENGINE — RECOIL STARTER ASSY.

RECOIL STARTER ASSY.

<u>NO.</u>	<u>PART NO.</u>	<u>PART NAME</u>	<u>QTY.</u>	<u>REMARKS</u>
1	28400ZH8013ZB	STARTER ASSY., RECOIL "NH1"(BLACK)	1	INCLUDES ITEMS W/*
2*	28410ZH8003ZB	CASE, RECOIL STARTER "NH1"(BLACK)	1	
3*	28420ZH8013	REEL, RECOIL STARTER	1	
4*	28422ZH8013	RATCHET, STARTER	2	
5*	28433ZH8003	GUIDE, RATCHET	1	
6*	28441ZH8003	SPRING, FRICTION	1	
7*	28442ZH8003	SPRING, RECOIL STARTER	1	
8*	28443ZH8003	SPRING, RETURN	2	
9*	28461ZH8003	KNOB, RECOIL STARTER	1	
10*	28462ZH8003	ROPE, RECOIL STARTER	1	
11*	90003ZH8003	SCREW, SETTING	1	
12	90008ZE2003	BOLT, FLANGE (6 X 10)	3	

GASKET KIT ASSY.

NO ARTWORK AVAILABLE

HONDA GX160K1TX2 ENGINE — GASKET KIT ASSY.

GASKET KIT ASSY.

<u>NO.</u>	<u>PART NO.</u>	<u>PART NAME</u>	<u>QTY.</u>	<u>REMARKS</u>
1	11381ZH8800	GASKET KIT	1	INCLUDES ITEMS W/*
2*	11381zh8801	GASKET, CASE COVER	1	
3*	12251ZF1800	GASKET, CYLINDER HEAD	1	
4*	12391ZE1000	GASKET, CYLINDER HEAD COVER	1	
5*	16212ZH8800	GASKET, INSULATOR	1	
6*	16221ZH8801	GASKET, CARBURETOR	1	
7*	18381ZH8800	GASKET, MUFFLER	1	

HONDA GX160K1TX2 ENGINE — LABELS ASSY.

LABELS ASSY.

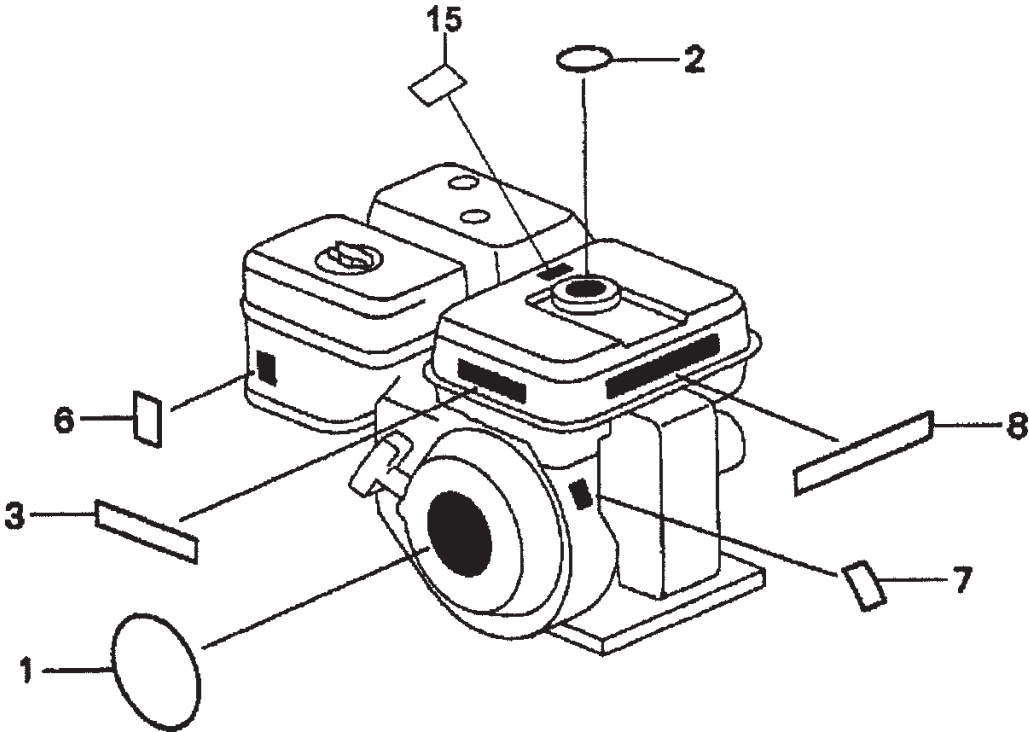

HONDA GX160K1TX2 ENGINE — LABELS ASSY.

LABELS ASSY.

<u>NO.</u>	<u>PART NO.</u>	<u>PART NAME</u>	<u>QTY.</u>	<u>REMARKS</u>
1	87521ZH8010	EMBLEM (INTERNAL)	1 USE UP TO ENGINE S/N 7438467
1	87521ZH8020	EMBLEM (5.5)	1 USE FROM ENGINE S/N 7438468
2	87522ZE1810	MARK, CAUTION (EXTERNAL)	1 USE UP TO ENGINE S/N 3063877
3	87522ZH9000	LABEL, CAUTION	1	
6	87528ZE1810	MARK, CHOKE	1	
7	87530ZH8810	LABEL, SPECIFICATION (EXT.)	1	
8	87532ZH8810	MARK, OIL ALERT (E)	1	
15	87586ZH7W00	LABEL, FUEL CAUTION	1	

PAYMENT TERMS

Terms of payment for parts are net 30 days.

FREIGHT POLICY

All parts orders will be shipped collect or prepaid with the charges added to the invoice. All shipments are F.O.B. point of origin. Multiquip's responsibility ceases when a signed manifest has been obtained from the carrier, and any claim for shortage or damage must be settled between the consignee and the carrier.

MINIMUM ORDER

The minimum charge for orders from Multiquip is \$15.00 net. Customers will be asked for instructions regarding handling of orders not meeting this requirement.

RETURNED GOODS POLICY

Return shipments will be accepted and credit will be allowed, subject to the following provisions:

1. A Returned Material Authorization must be approved by Multiquip prior to shipment.
2. To obtain a Return Material Authorization, a list must be provided to Multiquip Parts Sales that defines item numbers, quantities, and descriptions of the items to be returned.
 - a. The parts numbers and descriptions must match the current parts price list.
 - b. The list must be typed or computer generated.
 - c. The list must state the reason(s) for the return.
 - d. The list must reference the sales order(s) or invoice(s) under which the items were originally purchased.
 - e. The list must include the name and phone number of the person requesting the RMA.
3. A copy of the Return Material Authorization must accompany the return shipment.
4. Freight is at the sender's expense. All parts must be returned freight prepaid to Multiquip's designated receiving point.

5. Parts must be in new and resalable condition, in the original Multiquip package (if any), and with Multiquip part numbers clearly marked.
6. The following items are not returnable:
 - a. Obsolete parts. (If an item is in the price book and shows as being replaced by another item, it is obsolete.)
 - b. Any parts with a limited shelf life (such as gaskets, seals, "O" rings, and other rubber parts) that were purchased more than six months prior to the return date.
 - c. Any line item with an extended dealer net price of less than \$5.00.
 - d. Special order items.
 - e. Electrical components.
 - f. Paint, chemicals, and lubricants.
 - g. Decals and paper products.
 - h. Items purchased in kits.
7. The sender will be notified of any material received that is not acceptable.
8. Such material will be held for five working days from notification, pending instructions. If a reply is not received within five days, the material will be returned to the sender at his expense.
9. Credit on returned parts will be issued at dealer net price at time of the original purchase, less a 15% restocking charge.
10. In cases where an item is accepted, for which the original purchase document can not be determined, the price will be based on the list price that was effective twelve months prior to the RMA date.
11. Credit issued will be applied to future purchases only.

PRICING AND REBATES

Prices are subject to change without prior notice. Price changes are effective on a specific date and all orders received on or after that date will be billed at the revised price. Rebates for price declines and added charges for price increases will not be made for stock on hand at the time of any price change.

Multiquip reserves the right to quote and sell direct to Government agencies, and to Original Equipment Manufacturer accounts who use our products as integral parts of their own products.

SPECIAL EXPEDITING SERVICE

A \$35.00 surcharge will be added to the invoice for special handling including bus shipments, insured parcel post or in cases where Multiquip must personally deliver the parts to the carrier.

LIMITATIONS OF SELLER'S LIABILITY

Multiquip shall not be liable hereunder for damages in excess of the purchase price of the item with respect to which damages are claimed, and in no event shall Multiquip be liable for loss of profit or good will or for any other special, consequential or incidental damages.

LIMITATION OF WARRANTIES

No warranties, express or implied, are made in connection with the sale of parts or trade accessories nor as to any engine not manufactured by Multiquip. Such warranties made in connection with the sale of new, complete units are made exclusively by a statement of warranty packaged with such units, and Multiquip neither assumes nor authorizes any person to assume for it any other obligation or liability whatever in connection with the sale of its products. Apart from such written statement of warranty, there are no warranties, express, implied or statutory, which extend beyond the description of the products on the face hereof.

OPERATION AND PARTS MANUAL

HERE'S HOW TO GET HELP

PLEASE HAVE THE MODEL AND SERIAL
NUMBER *ON-HAND* WHEN CALLING

UNITED STATES

Multiquip Corporate Office

18910 Wilmington Ave. Tel. (800) 421-1244
Carson, CA 90746 Fax (800) 537-3927
Contact: mq@multiquip.com

Mayco Parts

800-306-2926 Fax: 800-672-7877
310-537-3700 Fax: 310-637-3284

Service Department

800-421-1244 Fax: 310-537-4259
310-537-3700

MQ Parts Department

800-427-1244 Fax: 800-672-7877
310-537-3700 Fax: 310-637-3284

Warranty Department

800-421-1244, Ext. 279 Fax: 310-537-1173
310-537-3700, Ext. 279

Technical Assistance

800-478-1244 Fax: 310-631-5032

MEXICO

MQ Cipsa

Carr. Fed. Mexico-Puebla KM 126.5 Tel: (52) 222-225-9900
Momoxpan, Cholula, Puebla 72760 Mexico Fax: (52) 222-285-0420
Contact: pmastretta@cipsa.com.mx

CANADA

Multiquip

4110 Industriel Boul. Tel: (450) 625-2244
Laval, Quebec, Canada H7L 6V3 Fax: (450) 625-8664
Contact: jmartin@multiquip.com

UNITED KINGDOM

Multiquip (UK) Limited Head Office

Hanover Mill, Fitzroy Street, Tel: 0161 339 2223
Ashton-under-Lyne, Fax: 0161 339 3226
Lancashire OL7 0TL
Contact: sales@multiquip.co.uk

BRAZIL

Multiquip

Av. Evandro Lins e Silva, 840 - grupo 505 Tel: 011-55-21-3433-9055
Barra de Tijuca - Rio de Janeiro Fax: 011-55-21-3433-9055
Contact: cnavarro@multiquip.com.br, srentes@multiquip.com.br

© COPYRIGHT 2006, MULTIQUIP INC.

Multiquip Inc and the MQ logo are registered trademarks of Multiquip Inc. and may not be used, reproduced, or altered without written permission. All other trademarks are the property of their respective owners and used with permission.

This manual **MUST** accompany the equipment at all times. This manual is considered a permanent part of the equipment and should remain with the unit if resold.

The information and specifications included in this publication were in effect at the time of approval for printing. Illustrations are based on the *MQ QP-205SH High Pressure Centrifugal Pump*. Illustrations, descriptions, references and technical data contained in this manual are for guidance only and may not be considered as binding. Multiquip Inc. reserves the right to discontinue or change specifications, design or the information published in this publication at any time without notice and without incurring any obligations.

Your Local Dealer is:

