

# OPERATION AND PARTS MANUAL



## **MODEL QP-2TE TRASH PUMP (Gasoline Engine)**

Revision #0 (02/04/05)

**THIS MANUAL MUST ACCOMPANY  
THE EQUIPMENT AT ALL TIMES.**

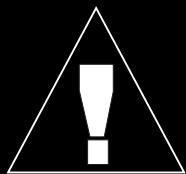

# WARNING

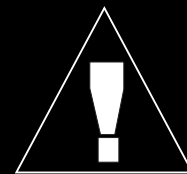

## **CALIFORNIA — Proposition 65 Warning**

Engine exhaust and some of its constituents are known to the State of California to cause cancer, birth defects and other reproductive harm.

## **HERE'S HOW TO GET HELP**

PLEASE HAVE THE MODEL AND SERIAL  
NUMBER *ON-HAND* WHEN CALLING

### **MULTIQUIP CORPORATE OFFICE**

18910 Wilmington Ave.

800-421-1244

Carson, CA 90746

FAX: 310-537-3927

Email: [mq@multiquip.com](mailto:mq@multiquip.com)

Internet: [www.multiquip.com](http://www.multiquip.com)

### **PARTS DEPARTMENT**

800-427-1244

FAX: 800-672-7877

310-537-3700

FAX: 310-637-3284

### **MAYCO PARTS**

800-306-2926

FAX: 800-672-7877

310-537-3700

FAX: 310-637-3284

### **SERVICE DEPARTMENT**

800-421-1244

FAX: 310-537-4259

310-537-3700

### **TECHNICAL ASSISTANCE**

800-478-1244

FAX: 310-631-5032

### **WARRANTY DEPARTMENT**

800-421-1244, EXT. 279

FAX: 310-537-1173

310-537-3700, EXT. 279

© COPYRIGHT 2004, Multiquip INC.

Multiquip Inc, the MQ logo are registered trademarks of Multiquip Inc. and may not be used, reproduced, or altered without written permission. All other trademarks are the property of their respective owners and used with permission.

This manual MUST accompany the equipment at all times. This manual is considered a permanent part of the equipment and should remain with the unit if resold.

The information and specifications included in this publication were in effect at the time of approval for printing. Illustrations are based on the *MQ Model QP-2TE Trash Pump*. Illustrations, descriptions, references and technical data contained in this manual are for guidance only and may not be considered as binding. Multiquip Inc. reserves the right to discontinue or change specifications, design or the information published in this publication at any time without notice and without incurring any obligations.

**To find the latest revision of this  
publication, visit our website at:  
[www.multiquip.com](http://www.multiquip.com)**



## QP-2TE Trash Pump

Here's How To Get Help .....	3
Table of Contents .....	4
Parts Ordering Procedures .....	5
Safety Message Alert Symbols .....	6-7
Rules For Safe Operation .....	8-9
Pump Specifications/Dimensions .....	10
Engine Specifications .....	11
General Information .....	12
Pump Components .....	13
Refueling .....	14
Basic Engine .....	15
Pre-Inspection (Engine) .....	16
Pre-Setup (Pump) .....	17
Initial Start-up (Engine) .....	18-19
Maintenance (Pump) .....	20-21
Maintenance (Engine).....	22-23
Preparation for Long-Term Storage .....	24
Troubleshooting (Engine) .....	26
Troubleshooting (Engine/Pump) .....	27
Explanation Of Code In Remarks Column .....	28
Suggested Spare Parts .....	29
Pump Assy. ....	30-33

## Robin EX170D50021 Engine

Crankcase Assembly .....	34-35
Crankshaft and Piston Assembly .....	36-37
Governor Assembly .....	38-39
Intake Exhaust Assembly .....	40-41
Air Cleaner Assembly .....	42-43
Cooling and Starting Assembly .....	44-45
Carburetor Assembly .....	46-47
Flywheel Assembly .....	48-49
Electric Device Assembly .....	50-51
Fuel Tank Assembly .....	52-53
Terms and Condition Of Sale — Parts .....	54

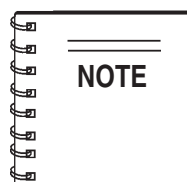

***Specification and part number are subject to change without notice.***

# PARTS ORDERING PROCEDURES

## When ordering parts, please supply the following information:

- Dealer account number
- Dealer name and address
- Shipping address (if different than billing address)
- Return fax number
- Applicable model number
- Quantity, part number and description of each part
- Specify preferred method of shipment:
  - ✓ FedEx or UPS Ground
  - ✓ FedEx or UPS Second Day or Third Day
  - ✓ FedEx or UPS Next Day
  - ✓ Federal Express Priority One
  - ✓ DHL
  - ✓ Truck

*Note: Unless otherwise indicated by customer, all orders are treated as "Standard Orders", and will ship within 24 hours. We will make every effort to ship "Air Shipments" the same day that the order is received, if prior to 2PM west coast time. "Stock Orders" must be so noted on fax or web forms.*



## Here's how to get help...

*Please have the model and serial number on hand when calling.*

### MULTIQUIP CORPORATE OFFICE

18910 Wilmington Ave. 800-421-1244  
 Carson, CA 90746 FAX: 310-537-3927  
 Email: mq@multiquip.com  
 Internet: www.multiquip.com

### PARTS DEPARTMENT

800-427-1244 FAX: 800-672-7877  
 310-537-3700 FAX: 310-637-3284

### MAYCO PARTS

800-306-2926 FAX: 800-672-7877  
 310-537-3700 FAX: 310-637-3284

### SERVICE DEPARTMENT

800-421-1244 FAX: 310-537-4259  
 310-537-3700

### TECHNICAL ASSISTANCE

800-478-1244 FAX: 310-631-5032

### WARRANTY DEPARTMENT

800-421-1244, EXT. 279 FAX: 310-537-1173  
 310-537-3700, EXT. 279

## Place Your Parts Order Via Web or Fax For Even More Savings!

*(Domestic USA Dealers Only)*

### Extra Discounts!

All parts orders which include complete part numbers and are received by our automated web parts order system, or by fax qualify for the following extra discounts:

Ordered via	Standard orders	Stock orders (\$750 list and above)
Fax	3%	10%
Web	5%	10%

### Special freight allowances when you order 10 or more line items via Web or Fax! \*\*

FedEx Ground Service **at no charge for freight**

*No other allowances on freight shipped by any other carrier.*

**\*\*Common nuts, bolts and washers (all items under \$1.00 list price) do not count towards the 10+ line items.**

NOTE: DISCOUNTS ARE SUBJECT TO CHANGE



MULTIQUIP INC.  
 18910 WILMINGTON AVENUE  
 POST OFFICE BOX 6254  
 CARSON, CALIFORNIA 90749  
 310-537-3700 • 800-421-1244  
 FAX: 310-537-3927  
 E-MAIL: mq@multiquip.com  
 INTERNET: www.multiquip.com

## Direct TOLL-FREE access to our Parts Department:

Toll-free nationwide — 800-427-1244  
 Toll-free FAX — 800-6-PARTS-7 (800/672-7877)

# QP- 2TE — SAFETY MESSAGE ALERT SYMBOLS

## FOR YOUR SAFETY AND THE SAFETY OF OTHERS!

Safety precautions should be followed at all times when operating this equipment. Failure to read and understand the Safety Messages and Operating Instructions could result in injury to yourself and others.

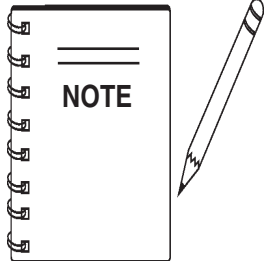

This Owner's Manual has been developed to provide complete instructions for the safe and efficient operation of the Multiquip **Model QP-2TE Trash Pump**. Refer to the engine manufacturers instructions for data relative to its safe operation. **Before using this pump, ensure that the operating individual has read and understands all instructions in this manual.**

## SAFETY MESSAGE ALERT SYMBOLS

The three (3) Safety Messages shown below will inform you about potential hazards that could injure you or others. The Safety Messages specifically address the level of exposure to the operator, and are preceded by one of three words: **DANGER**, **WARNING**, or **CAUTION**.

### **DANGER**

You **WILL** be **KILLED** or **SERIOUSLY INJURED** if you **DO NOT** follow these directions.

### **WARNING**

You **CAN** be **KILLED** or **SERIOUSLY INJURED** if you **DO NOT** follow these directions.

### **CAUTION**

You **CAN** be **INJURED** if you **DO NOT** follow these directions.

Potential hazards associated with the QP-2TE Trash Pump operation will be referenced with Hazard Symbols which appear throughout this manual, and will be referenced in conjunction with Safety Message Alert Symbols.

## HAZARD SYMBOLS

### **Lethal Exhaust Gases**



Engine exhaust gases contain poisonous carbon monoxide. This gas is colorless and odorless, and can cause death if inhaled. **NEVER** operate this equipment in a confined area or enclosed structure that does not provide ample free flow air.

### **Explosive Fuel**



**GASOLINE** is extremely flammable, and its vapors can cause an explosion if ignited. **DO NOT** start the engine near spilled fuel or combustible fluids. **DO NOT** fill the fuel tank while the engine is running or hot. **DO NOT** overfill tank, since spilled fuel could ignite if it comes into contact with hot engine parts or sparks from the ignition system. Store fuel in approved containers, in well-ventilated areas and away from sparks and flames. **NEVER**

### **Burn Hazards**



Engine components can generate extreme heat. To prevent burns, **DO NOT** touch these areas while the engine is running or immediately after operations. Never operate the engine with heat shields or heat guards removed.

### **Rotating Parts**



**NEVER** operate equipment with covers, or guards removed. Keep fingers, hands, hair and clothing away from all moving parts to prevent injury.

# QP- 2TE — SAFETY MESSAGE ALERT SYMBOLS



## Accidental Starting



OFF

**ALWAYS** place the engine ON/OFF switch in the **OFF** position when the pump is not in use.



## Respiratory Hazard



**ALWAYS** wear approved respiratory protection.



## Sight and Hearing hazard

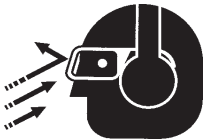

**ALWAYS** wear approved eye and hearing protection.



## Equipment Damage Messages

Other important messages are provided throughout this manual to help prevent damage to your pump, other property, or the surrounding environment.

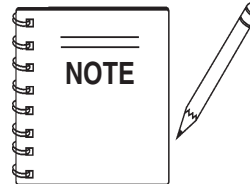

This pump, other property, or the surrounding environment could be damaged if you do not follow instructions.

# RULES FOR SAFE OPERATION

## DANGER

Failure to follow instructions in this manual may lead to serious injury or even death! This equipment is to be operated by trained and qualified personnel only! This equipment is for industrial use only.

The following safety guidelines should always be used when operating the **trash pump**:

### GENERAL SAFETY

- **DO NOT** operate or service this equipment before reading this entire manual.



- This equipment should not be operated by persons under 18 years of age.
- **NEVER** operate this equipment without proper protective clothing, shatterproof glasses, steel-toed boots and other protective devices required by the job.



- **NEVER** operate this equipment when not feeling well due to fatigue, illness or taking medicine.



- **NEVER** operate this equipment under the influence of drugs or alcohol.



- Whenever necessary, replace nameplate, operation and safety decals when they become difficult read.
- **ALWAYS** check the machine for loosened threads or bolts before starting.
- **ALWAYS** wear proper respiratory (mask) hearing and eye protection equipment when operating the pump.



- **NEVER** touch the hot exhaust manifold, muffler or cylinder. Allow these parts to cool before servicing engine or pump.

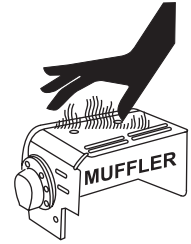

- **High Temperatures** – Allow the engine to cool before adding fuel or performing service and maintenance functions. Contact with *hot* components can cause serious burns.

- The engine of this pump requires an adequate free flow of cooling air. **NEVER!** operate the pump in any enclosed or narrow area where free flow of the air is restricted. If the air flow is restricted it will cause serious damage to the pump or engine and may cause injury to people and property. Remember the pump's engine gives off **DEADLY** gases.

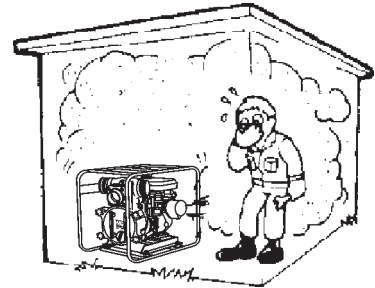

- **ALWAYS** refuel in a well-ventilated area, away from sparks and open flames.

- **ALWAYS** use extreme caution when working with **flammable** liquids. When refueling, **stop the engine** and allow it to cool. **DO NOT** smoke around or near the machine. Fire or explosion could result from fuel vapors, or if fuel is spilled on a hot engine.

- **NEVER** operate the pump in an **explosive atmosphere** or near combustible materials. An explosion or fire could result causing severe **bodily harm or even death**.

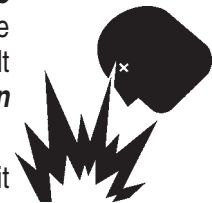

- Topping-off to filler port is dangerous, as it tends to spill fuel.

- Refer to the **Engine Owner's Manual** for engine technical questions or information.

- **NEVER** use accessories or attachments, which are not recommended by Multiquip for this equipment. Damage to the equipment and/or injury to user may result.

- Manufacturer does not assume responsibility for any accident due to equipment modifications.

# RULES FOR SAFE OPERATION

- **NEVER** Run engine without air cleaner. Severe engine damage may occur.
- **ALWAYS** read, understand, and follow procedures in Operator's Manual before attempting to operate equipment.
- **ALWAYS** be sure the operator is familiar with proper safety precautions and operation techniques before using pump.
- **ALWAYS** store equipment properly when it is not being used. Equipment should be stored in a clean, dry location out of the reach of children.
- **NEVER** leave the pump unattended, turn off engine when unattended.
- Unauthorized equipment modifications will void all warranties.
- **NEVER** pump volatile, explosive, flammable or low flash point fluids. These fluids could ignite or explode.
- **NEVER** operate the pump in an **explosive** atmosphere.
- Before starting the pump, check that the clean-out cover is securely fasten.
- **ALWAYS** ensure pump is on level ground before use.
- Become familiar with the components of the pump before operating.
- **NEVER** pump corrosive chemicals or water containing toxic substances. These fluids could create serious health and environmental hazards. Contact local authorities for assistance.
- **NEVER** open the priming plug when pump is hot. Hot water inside could be pressurized much like the radiator of an automobile. Allow pump to cool to the touch before loosening plug.
- **NEVER** open the pump housing during operation or start the pump with the clean-out cover removed. The rotating impeller inside the pump can cut or sever objects caught in it.
- **NEVER** block or restrict flow from discharge hose. Remove kinks from discharge line before starting pump. Operation with a blocked discharge line can cause water inside pump to overheat.
- **ALWAYS** fill the pump casing with water before starting the engine. Failure to maintain water inside the pump housing will cause severe damage to the pump.
- In winter drain water from pump housing to prevent freezing.

- **High Temperatures** – Always stop engine and allow the engine to cool before adding fuel, oil or performing service and maintenance functions. Contact with *hot* components can cause serious burns.
- **NEVER** disconnect any "**emergency or safety devices**". These devices are intended for operator safety. Disconnection of these devices can cause severe injury, bodily harm or even death! Disconnection of any of these devices will void all warranties.

## Maintenance Safety

- **NEVER** lubricate components or attempt service on a running machine.
- **ALWAYS** allow the machine a proper amount of time to cool before servicing.
- Keep the machinery in proper running condition.
- Fix damage to the machine immediately and always replace broken parts, or missing decals.
- Dispose of hazardous waste properly. Examples of potentially hazardous waste are used motor oil, fuel and fuel filters.
- **DO NOT** use food or plastic containers to dispose of hazardous waste.
- **DO NOT** pour waste, oil or fuel directly onto the ground, down a drain or into any water source.

## Emergencies

- **ALWAYS** know the location of the nearest **fire extinguisher**.



- **ALWAYS** know the location of the nearest **first aid kit**.



- In emergencies **always** know the location of the nearest phone or **keep a phone on the job site**. Also know the phone numbers of the nearest **ambulance, doctor** and **fire department**. This information will be invaluable in case of an emergency.

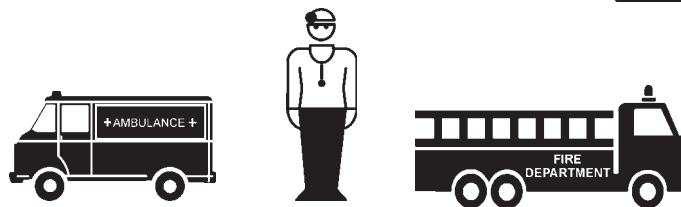

# QP-2TE — SPECIFICATIONS/DIMENSIONS (PUMP)

**Table 1. Specifications (Pump)**

	Model	QP-2TE
<b>Pump</b>	Type	Trash Pump
	Suction & Discharge Size	2.00 in. (51 mm.)
	Maximum Pumping Capacity	211 gallons/minute (800 liters/minute)
	Max. Solids Diameter	1.0 in. (25 mm.)
	Max. Lift	25 ft. (7.62 meters)
	Max. Head	98 ft. (30.0 meters)
	<b>Dimension (L x W x H)</b>	26.8 x 18.3 X 20.3 in. (680 X 465 X 516 mm.)
<b>Dry Net Weight</b>	97 lbs. (44 Kg.)	

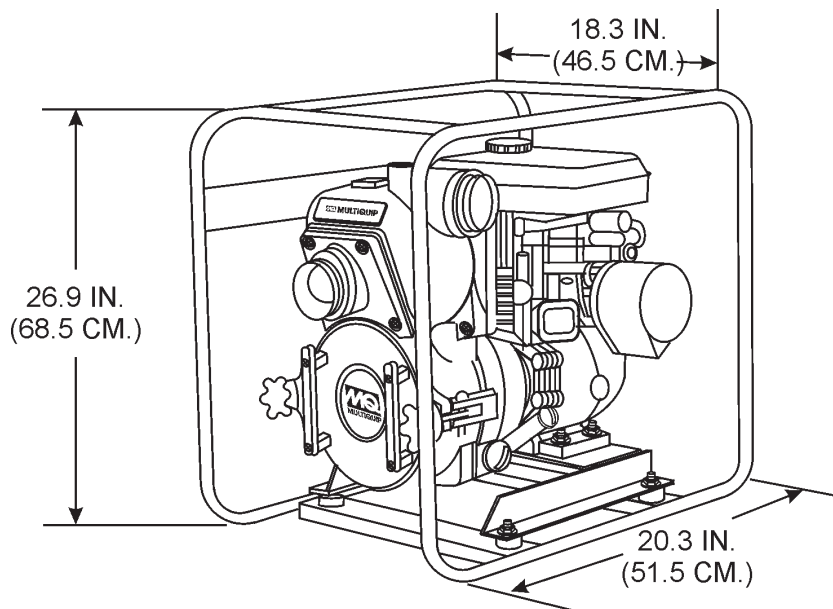
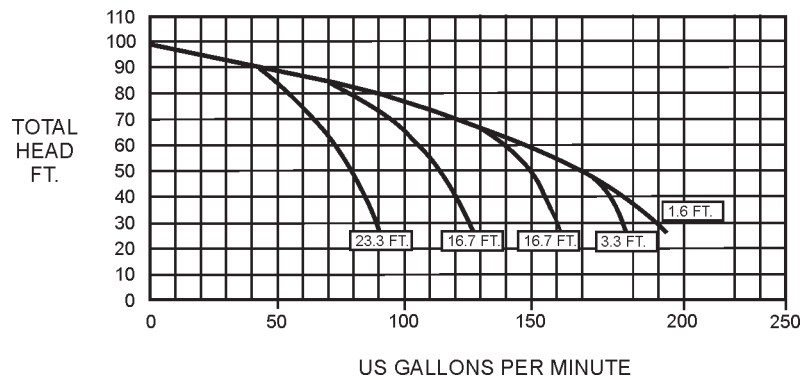

**Figure 1. QP-2TE Dimensions**

**Table 2. Specifications (Engine)**

<b>Engine</b>	<b>Model</b>	<b>ROBIN EX170D50021</b>
	<b>Type</b>	Air-cooled 4 stroke, Single Cylinder, Overhead Camshaft Gasoline Engine
	<b>Displacement</b>	169 cc (10.3 cu-in)
	<b>Max Output</b>	5.7 H.P./4,000 R.P.M.
	<b>Continuous Output</b>	4.0 H.P./3,600 R.P.M.
	<b>Fuel Tank Capacity</b>	Approx. .95 U.S. gallons (3.6 liters)
	<b>Fuel</b>	Unleaded Automobile Gasoline
	<b>Lube Oil Capacity</b>	.634 qts. (0.6 liters)
	<b>Speed Control Method</b>	Centrifugal Fly-weight Type
	<b>Spark Plug</b>	NGK BR-6HS (Champion RL86C)
<b>Dimension (L x W x H)</b>		11.96 x 13.93 x 13.1 in. (304 x 354 x 335 mm)
<b>Dry Net Weight</b>		33 lbs. (15 Kg.)

## APPLICATION

The **QP-2TE Trash Pump** is designed to be used for dewatering applications. Both the suction and discharge ports on the QP-2TE trash pump use a 2-inch diameter opening, which allows the pump to pump at a rate of approximately 211 gallons/minute (gpm) or 800 liters/minute (lpm).

Trash or self-priming pumps are designed to purge air from the suction line and create a partial vacuum in the pump body. The reduced atmospheric pressure inside the pump allows water to flow through the suction line and into the pump body. The centrifugal force created by the rotating impeller pressurizes the water and expels it from the pump.

## Power Plant

This trash pump is powered by an 5.7 horsepower air cooled 4-stroke, single cylinder **ROBIN EX-170** gasoline engine that incorporates a low "**Oil Alert Feature**"

## Oil Alert Feature

In the event of **low oil** or **no oil**, the ROBIN EX-170 engine has a built-in oil alarm engine shutdown feature. In the event the oil level is low the engine will automatically shut down.

## Trash Pump

Trash pumps derive their name from their ability to handle a greater amount of debris and solids than standard centrifugal pumps. This pump generally handle solids up to 1/2 the size of the discharge opening making them less likely to clog. Also trash pumps are capable of handling water with 25% solids by weight.

The advantage of using a trash pump is that it can be quickly and easily disassembled in the field "**without tools**" and easily cleaned when clogged.

## Suction Lift

This pump is intended to be used for dewatering applications and is capable of suction lifts up to 25 feet at sea level. For optimal suction lift performance, keep the suction hose or line as short as possible. In general, always place the pump as close to the water as possible.

## Pump Support

The pump should always be placed on **solid stationary ground** in a level position.

**NEVER** place the pump on **soft soil**. The suction hose or pipe connection should always be checked for tightness and leaks. A small suction leak in the hose or fittings could prevent the pump from priming.

## Elevation

Higher elevations will effect the performance of the pump. Due to less atmospheric pressure at higher altitudes, pumps **DO NOT** have the priming ability that they have at sea level. This is due to the "thinner air" or lack of oxygen at higher altitudes.

A general rule of thumb is that for every 1,000 feet of elevation above sea level a pump will lose one foot of priming ability.

For example, in Flagstaff, Arizona where the elevation is approximately 7,000 feet, the pump would have a suction lift of 25 feet rather than the 18 feet at sea level. Table 3 shows suction lift at various elevations.

**Table 3. Suction Lift at Various Elevations**

Altitude Feet (Meters)	Suction Lift in Feet (Meters)			
	Sea Level	10.0 (3.048)	15.0 (4.572)	20.0 (6.096)
2,000 (610)	8.80 (2.680)	13.2 (4.023)	17.6 (5.364)	22.0 (6.705)
4,000 (1,219)	7.80 (2.377)	11.7 (3.566)	15.6 (4.754)	19.5 (5.943)
6,000 (1,829)	6.90 (2.103)	10.4 (3.169)	13.8 (4.206)	17.3 (5.273)
8,000 (2,438)	6.20 (1.889)	9.30 (2.834)	12.4 (3.779)	15.5 (4.724)
10,000 (3,048)	5.70 (1.737)	8.60 (2.621)	11.4 (3.474)	14.3 (4.358)

Table 4 shows percentage drops in performance as elevation increases.

**Table 4. Performance Loss at Various Elevations**

Altitude Feet (Meters)	Discharge Flow	Discharge Head
Sea Level	100%	100%
2,000 (610)	97%	95%
4,000 (1,219)	95%	91%
6,000 (1,829)	93%	87%
8,000 (2,438)	91%	83%
10,000 (3,048)	88%	78%

## QP-2TE — PUMP COMPONENTS

Figure 2 shows a typical application using the QP- 2TE Trash pump. Please note that this pump is intended for the removal of clean water and water containing some debris and solids. Maximum size of solids should not exceed 1.0 inch (25 mm) in diameter. **DO NOT** set strainer on bottom of water bed. Placing the strainer above the water bed will prevent the pump from drawing in excessive amounts of sand and foreign debris.

**Figure 2. QP- 2TE Pump Application**

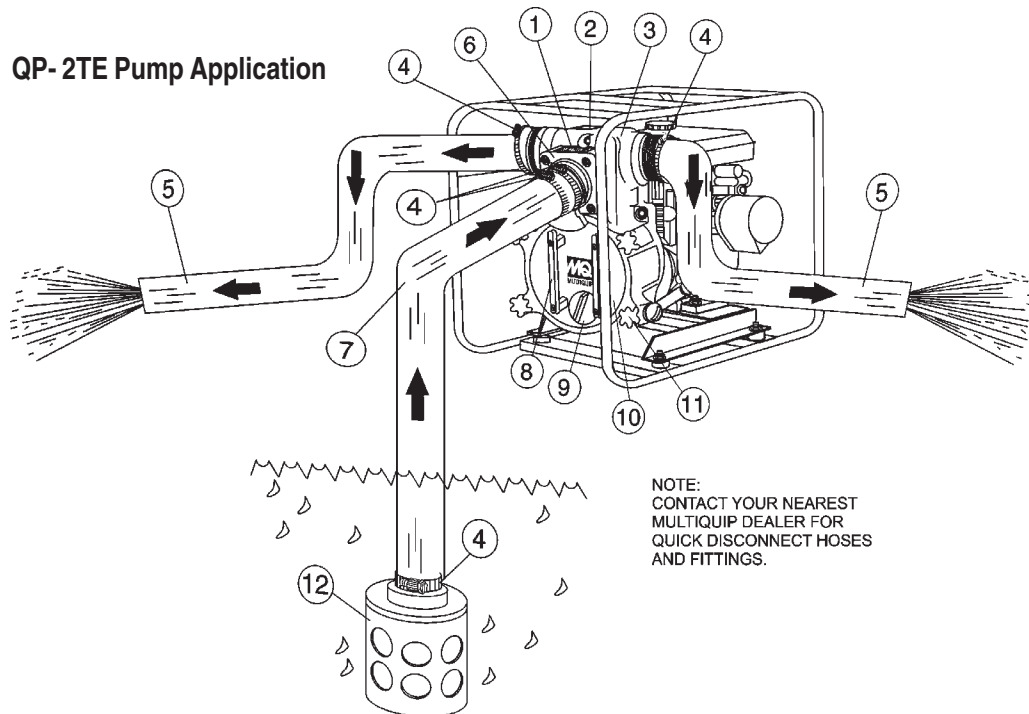

1. **Pump** – The model QP- 2TE is a 2-inch trash pump used in general dewatering applications. Typical dewatering applications consist of manholes, septic tanks, fast and slow seepage ditch water, silt water, mud water and muck water.
2. **Fill Cap** – Prior to operation, the pump casing should be filled with water. Remove this cap to add water to the pump. After the initial prime, a sufficient amount of water will be retained in the casing so that the operator will not need to re-prime later.  
If the casing is dry or has insufficient water, the pump will have difficulty in priming which could lead to premature mechanical seal wear thus causing damage to the pump.
3. **Discharge Port** – Connect a 2-inch discharge hose to this port.
4. **Worm Clamp** – Used to secure the hose to the inlet and outlet ports on the pump. Use two clamps to secure the hose on the inlet side of the pump.
5. **Discharge Hose** – Connect this flexible rubber hose to the discharge port on the pump. Make sure that the hose lays flat and is not kinked. Use only recommended type discharge hose. Contact Multiquip Parts Department for ordering information.
6. **Suction Port** – Connect a 2-inch inlet hose to this port. Use two worm clamps to secure the hose.
7. **Suction Hose** – Connect this flexible rubber hose to the suction portion the pump. Make sure that the hose lays flat and is not kinked. Use only recommended type suction hose. Contact Multiquip Parts Department for ordering information.
8. **Clean-out Cover Handles** – To gain access to the pump's clean-out area, grip both handles, then pull to remove cover. Make sure both locking knobs have been released before attempting to remove clean-out cover.
9. **Drain Plug** – Remove this plug to drain water from the pump.
10. **Clean-out Cover** – Remove cover to gain access to the clean-out area.
11. **Locking Knobs** – Turn both knobs clockwise to secure clean-out cover, turn counterclockwise to release cover.
12. **Strainer** – Always attach a strainer to the bottom side of the suction hose to prevent large objects and debris from entering the pump. Strainer should be positioned so that it will remain completely under water. Running the pump with the strainer above water for long periods can damage pump.



**DANGER**

Adding fuel to the tank should be done only when the engine is stopped and has had an opportunity to cool down. In the event of a fuel spill, **DO NOT** attempt to start the engine until the fuel residue has been completely wiped up, and the area surrounding the engine is dry. If pump is placed in a truck bed with a plastic liner, **REMOVE** pump from truck bed and place on ground (Figure 3) to refuel. The possibility of **fire** or **explosion** exists, due to static electricity.

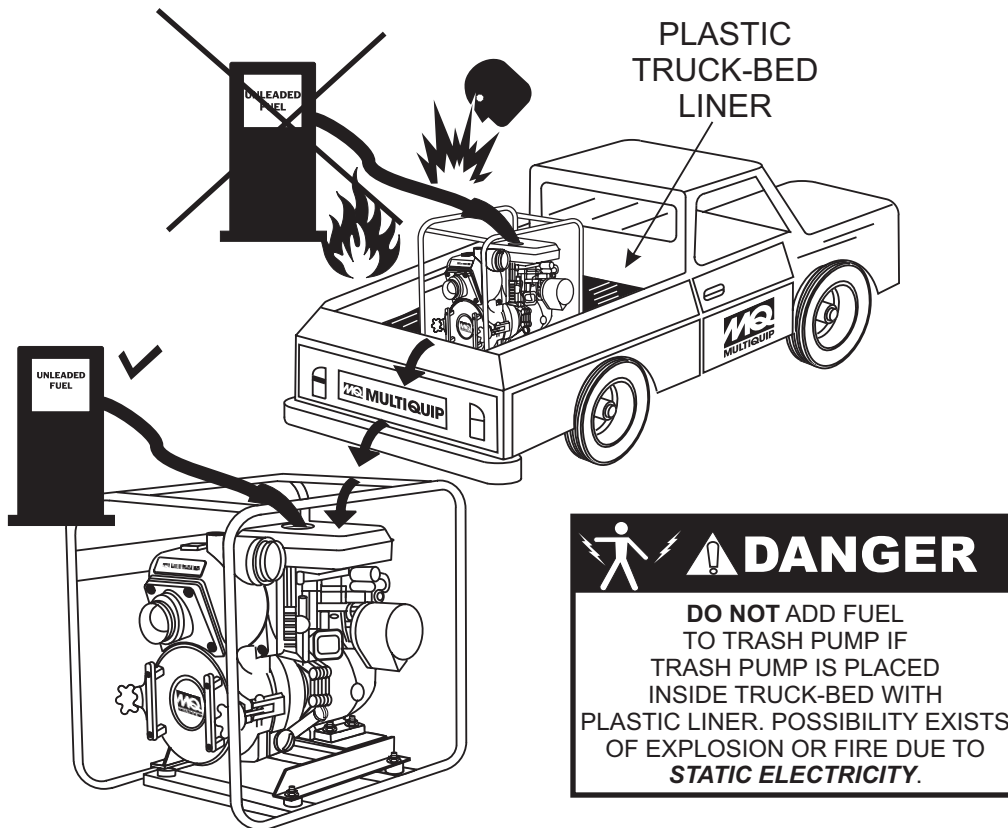

Figure 3. Pump Refueling

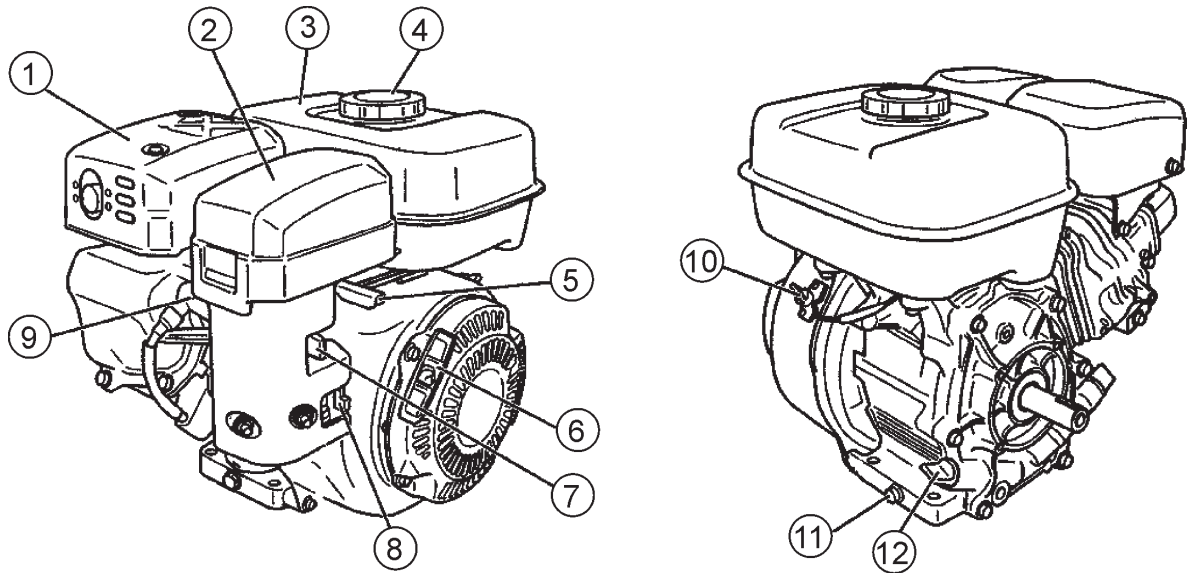



Figure 4. Engine Controls and Components

## INITIAL SERVICING

The engine (Figure 4) must be checked for proper lubrication and filled with fuel prior to operation. Refer to the **ROBIN** engine service manual for instructions and details for proper operation and servicing.

1. **Muffler** – Used to reduce noise and emissions.

**! WARNING**



Engine components can generate extreme heat. To prevent burns, **DO NOT** touch these areas while the engine is running or immediately after operating. **NEVER** operate the engine with the muffler removed.

2. **Air Cleaner** – Prevents dirt and other debris from entering the fuel system. Remove wing-nut on top of air filter canister to gain access to filter element.
3. **Fuel Tank** – Holds unleaded gasoline. For additional information refer to ROBIN engine owner's manual.
4. **Fuel Filler Cap** – Remove this cap to add unleaded gasoline to the fuel tank. Make sure cap is tightened securely. **DO NOT** over fill.

**! DANGER**



Adding fuel to the tank should be done only when the engine is stopped and has had an opportunity to cool down. In the event of a fuel spill, **DO NOT** attempt to start the engine until the fuel residue has been completely wiped up, and the area surrounding the engine is dry.

5. **Throttle Lever** – Used to adjust engine RPM speed (lever advanced forward **SLOW**, lever back toward operator **FAST**).
6. **Recoil Starter (pull rope)** – Manual-starting method. Pull the starter grip until resistance is felt, then pull briskly and smoothly.
7. **Choke Lever** – Used in the starting of a cold engine, or in cold weather conditions. The choke enriches the fuel mixture.
8. **Fuel Valve Lever** – **OPEN** to let fuel flow, **CLOSE** to stop the flow of fuel.
9. **Spark Plug** – Provides spark to the ignition system. Set spark plug gap to 0.6 - 0.7 mm (0.028 - 0.031 inch) Clean spark plug once a week.
10. **Engine ON/OFF Switch** – ON position permits engine starting, OFF position stops engine operations.
11. **Oil Drain Plug** – Remove this plug to drain engine oil from the crankcase.
12. **Oil Dipstick/ Filler Cap**– Remove the filler cap dipstick when checking the engine oil level. Add engine oil through this filler port. See Table 5 for recommended type engine oil.

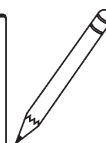
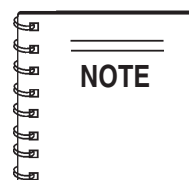

Operating the engine without an air filter, with a damaged air filter, or a filter in need of replacement will allow dirt to enter the engine, causing rapid engine wear.

# QP- 2TE — PRE-INSPECTION (ENGINE)

## CAUTION



**NEVER** operate the pump in a confined area or enclosed area structure that does not provide ample **free flow of air**.

**ALWAYS** wear approved eye and hearing protection before operating the pump.

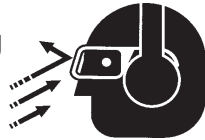

### Before Starting

1. Read safety instructions at the beginning of manual.
2. Clean the pump, removing dirt and dust, particularly the engine cooling air inlet, carburetor and air cleaner.
3. Check the air filter for dirt and dust. If air filter is dirty, replace air filter with a new one as required.
4. Check carburetor for external dirt and dust. Clean with dry compressed air.
5. Check fastening nuts and bolts for tightness.



### Engine Oil Check

1. To check the engine oil level, place the pump on secure level ground with the engine stopped.
2. Remove the filler dipstick from the engine oil filler hole (Figure 5) and wipe clean.

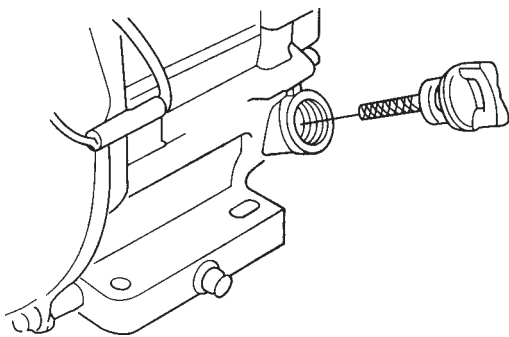

Figure 5. Engine Oil Dipstick (Removal)

3. Insert and remove the dipstick without screwing it into the filler neck. Check the oil level shown on the dipstick.
4. If the oil level is low (Figure 6), fill to the edge of the oil filler hole with the recommended oil type (Table 5). Maximum oil capacity is 1.16 quarts (1.1 liters)

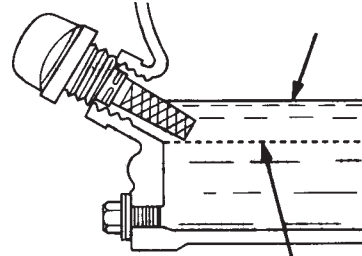

Figure 6. Engine Oil Dipstick (Oil Level)

Table 5. Oil Type

Season	Temperature	Oil Type
Summer	25°C or Higher	SAE 10W-30
Spring/Fall	25°C~10°C	SAE 10W-30/20
Winter	0°C or Lower	SAE 10W-10

## Explosive Fuel



## DANGER

Motor fuels are highly flammable and can be dangerous if mishandled. **DO NOT** smoke while refueling. **DO NOT** attempt to refuel the pump if the engine is **hot!** or **running**.

### Fuel Check

1. Remove the gasoline cap located on top of fuel tank.
2. Visually inspect to see if the fuel level is low. If fuel is low, replenish with unleaded fuel.
3. When refueling, be sure to use a strainer for filtration. **DO NOT** top-off fuel. Wipe up any spilled fuel **immediately!**

## Before Starting

1. Read safety instructions at the beginning of manual.
2. Place pump as near to water as possible, on a firm flat, level surface.
3. To prime pump, remove fill cap (Figure 2) and fill pump casing with water. If the pump casing is not filled with water before starting, it will not begin pumping.

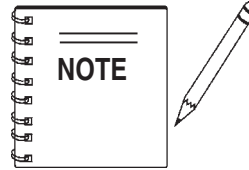

Suction and discharge hoses are available from Multiquip. Contact your nearest dealer for more information.

### CAUTION

Pump casing **must** be filled with water before using pump. Otherwise pump will not be able to begin pumping.

### WARNING

**DO NOT** open **fill cap** if pump is **hot!** Water inside may be under pressure.

4. Check for **leaks** between pump and engine. If water is leaking between the pump and engine housing, the seal inside the pump may be worn or damaged. Continued operation of the pump is not recommended. Further usage of the pump under these conditions may cause severe water damage to engine.

## Hoses and Clamps

1. Check that all hoses are **securely** attached to the pump. Make certain suction hose (Figure 2) does not have any air leakage. Tighten hose clamps and couplings as required.
2. It is recommended that 2 clamps be used when securing the suction hose to the inlet side (suction) of the pump.
3. Remember suction hoses must be **rigid** enough not to collapse when the pump is in operation.
4. Check that the **discharge** hose (Figure 2) is not restricted. Place hose so that it lays as straight as it is possible on the ground. Remove any twists or sharp bends from hose which may block the flow of water.

5. The discharge hose is usually a **collapsible** (thin-walled) hose, however if a thin-walled discharge hose is not available, a rigid suction hose can be substituted in its place.
6. Make sure the **suction strainer** (Figure 2) is clean and securely attached to the water end of the suction hose. The strainer is designed to protect the pump by preventing large objects from being pulled into the pump.

### CAUTION

The strainer should be positioned so it will remain completely **under water**. Running the pump with the strainer above water for long periods can damage the pump.

### CAUTION

**DO NOT** pump flammable fluids, corrosive chemicals or fluids containing toxic substances. These fluids can create potentially dangerous health and environmental hazards. Contact local authorities for assistance.

### CAUTION

This pump uses a water-cooled **mechanical seal** to prevent water from seeping into the engine. The passage of water through the pump casing lubricates the seal and prevents it from overheating. **NEVER!** operate the pump without water in the casing as this will cause damage to the mechanical seal.

# QP- 2TE — INITIAL START-UP (ENGINE)

## CAUTION



**DO NOT** attempt to operate the pump until the Safety, General Information and Inspection sections of this manual have been *read and thoroughly understood*.

This section is intended to assist the operator with the *initial start-up* of the trash pump. It is extremely important that this section be read carefully before attempting to use the pump in the field.

### Starting the Engine (ROBIN engine)

1. Place the engine *fuel valve lever* (Figure 7) to the "ON" position.

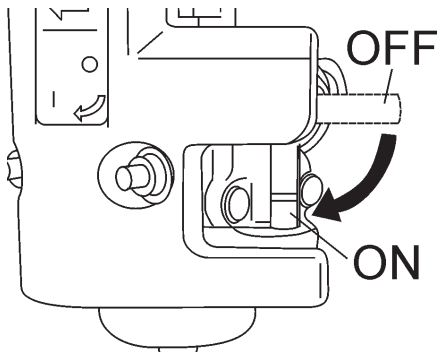

Figure 7. Engine Fuel Valve Lever (ON Position)

2. Move the *throttle lever* (Figure 8) away from the slow position, about 1/3 of the way toward the fast position.

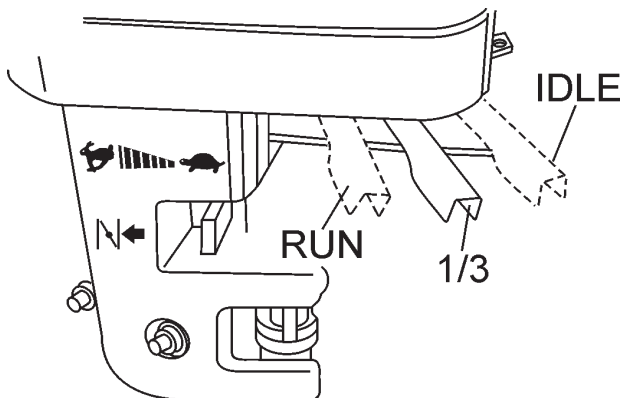

Figure 8. Throttle Lever (1/3 Start Position)

3. Place the *choke lever* (Figure 9) in the "CLOSED" position if starting a *cold* engine.

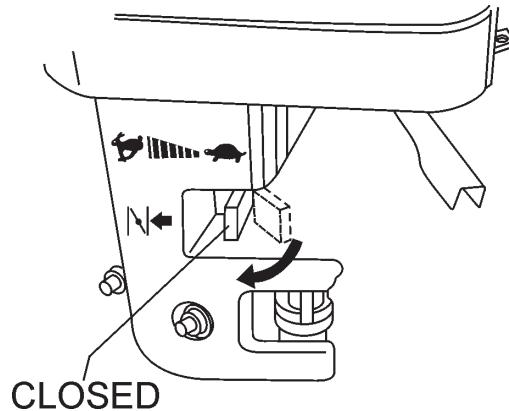

Figure 9. Engine Choke Lever (Closed)

4. Place the *choke lever* (Figure 10) in the "OPEN" position if starting a *warm engine* or the *temperature is warm*.

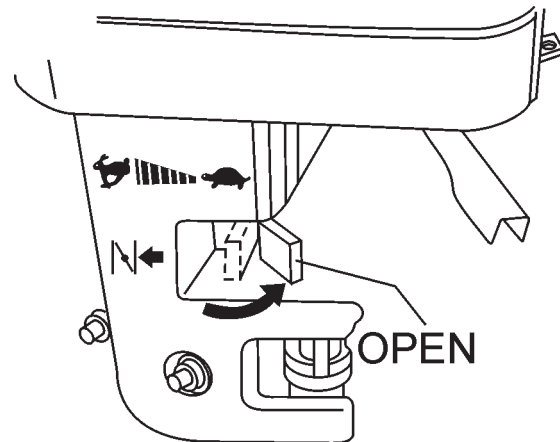

Figure 10. Engine Choke Lever (Open)

5. Place the *engine ON/OFF switch* (Figure 11) in the "ON" position.



Figure 11. Engine ON/OFF Switch (ON Position)

## QP- 2TE — INITIAL START-UP (ENGINE)

- Grasp the starter grip (Figure 12) and slowly pull it out. The resistance becomes the hardest at a certain position, corresponding to the compression point. Pull the starter grip briskly and smoothly for starting.

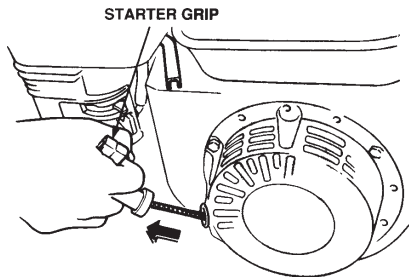

Figure 12. Starter Grip

- If the engine has started, slowly return the choke lever (Figure 13) to the **OPEN** position. If the engine has not started repeat steps 1 through 6.

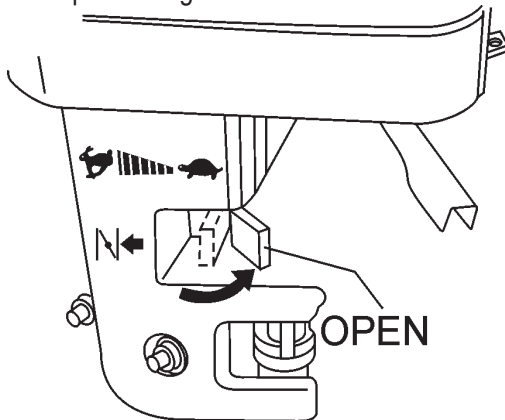

Figure 13. Choke Lever (Open)

- Before the pump is placed into operation, run the engine for several minutes. Check for fuel leaks, and noises that would associate with a loose component.
- To begin pumping, place the throttle lever (Figure 14) in the **"RUN"** position.

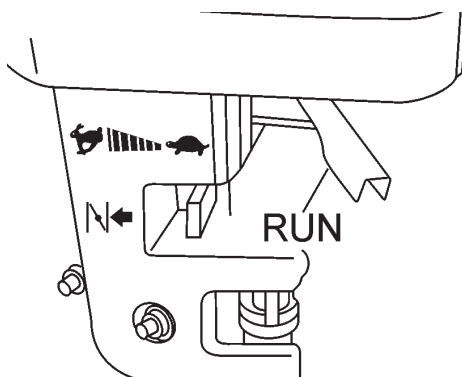

Figure 14. Throttle Lever (Run)

### **CAUTION**

**ALWAYS** run engine at **full speed** while pumping.

### Stopping The Engine

#### Normal Shutdown

- Move the throttle lever to the **IDLE** position (Figure 15) and run the engine for three minutes at low speed.

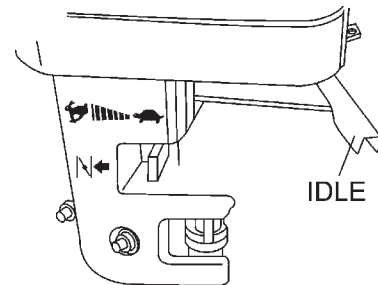

Figure 15. Throttle Lever (Idle)

- After the engine **cools**, turn the engine ON/OFF switch to the **"OFF"** position (Figure 16).

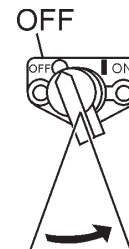

Figure 16. Engine ON/OFF Switch (OFF)

- Place the **fuel shut-off lever** (Figure 17) in the **OFF** position.

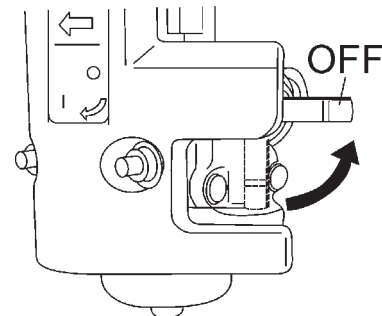

Figure 17. Fuel Valve Lever (OFF)

#### Emergency Showdown

- Move the throttle lever quickly to the **IDLE** position, and place the engine ON/OFF switch in the **OFF** position.

## Pump Vacuum Test

### CAUTION

**DO NOT** attempt to start the engine unless the pump has previously been **primed** with water. Severe pump damage will occur if pump has not been primed.

To perform the pump vacuum test do the following:

1. Remove the pump fill cap (Figure 2), and fill the pump with water.
2. Start the engine as outlined in the initial start-up section, and wait for the pump to begin pumping.
3. As shown in Figure 18 (next page), place a water hose inside the discharge opening of the pump, and turn on the water. This flow of water into the discharge opening will **prevent** the pump from running dry.
4. Place the **Pump Vacuum Tester** (P/N 7000030) over the pump suction (inlet) opening (Figure 18) with the vacuum gauge facing upwards. It may be necessary to apply a small amount of water around the rubber seal of the vacuum tester to make a good suction fit.
5. Check and make sure that there are no air leaks between the vacuum tester and the inlet port on the pump. If air leaks are present reset vacuum tester.
6. Run the pump for a few minutes while monitoring the vacuum gauge. If the gauge indicates a reading between -25 and -20 in. Hg. (inches of mercury) then it can be assumed that the pump is working correctly.

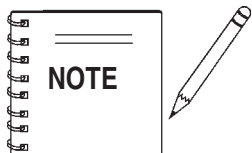

25 in. Hg (inches of mercury) translates into 25 feet of lift at **sea level**.

7. If the vacuum tester gauge indicates a reading **below** -20 in. Hg, it can then be assumed that the pump is not functioning correctly, and corrective action needs to be taken.
6. To test the **flapper valve**, shut down the engine. The vacuum tester should remain attached to the pump suction inlet port by vacuum. This indicates the pump's flapper valve is seating properly to hold water in the suction hose when the engine is stopped. This prevents backflow and allows for faster priming when the engine is restarted.

## Adjusting Impeller Clearance

1. If it is necessary to replace impeller or volute, be sure clearance between impeller and volute is adjusted correctly.
2. The impeller should be as close to the volute as possible without rubbing against it. Clearance is adjusted by adding or removing **shims** from behind the impeller.
3. Check clearance between impeller and insert by slowly pulling starter rope to turn impeller. Remove spark plug to make it easier to turn impeller.

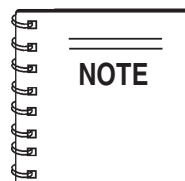

It is important not to remove too many shims or the clearance between the impeller and volute will become **too wide** and pump performance will be reduced. Remember as the impeller wear

down, additional shims may be required to maintain the clearance between the impeller and insert.

4. Check the impeller **every six months** for wear, and for clearance between the impeller face and the volute. Also check the shaft seal for wear, as well as the shaft sleeve.

## Pump Cleaning

After pumping water containing large amounts of dirt and debris, perform the following:

1. Remove the drain plug from the pump housing (Figure 2) and drain any water left in the pump.
2. Loosen the two locking hand knobs (turn counterclockwise) and remove **clean-out cover**.
3. Clean and remove dirt, debris from pump casing. Inspect impeller and volute for wear. Replace any damaged or worn parts.

### CAUTION

The impeller may develop **sharp edges**. Use extreme care when cleaning around the impeller to prevent being cut.

## CAUTION

DO NOT RUN PUMP WITHOUT WATER.

PLACE VACUUM TESTER OVER PUMP SUCTION PORT

DISCHARGE PORT

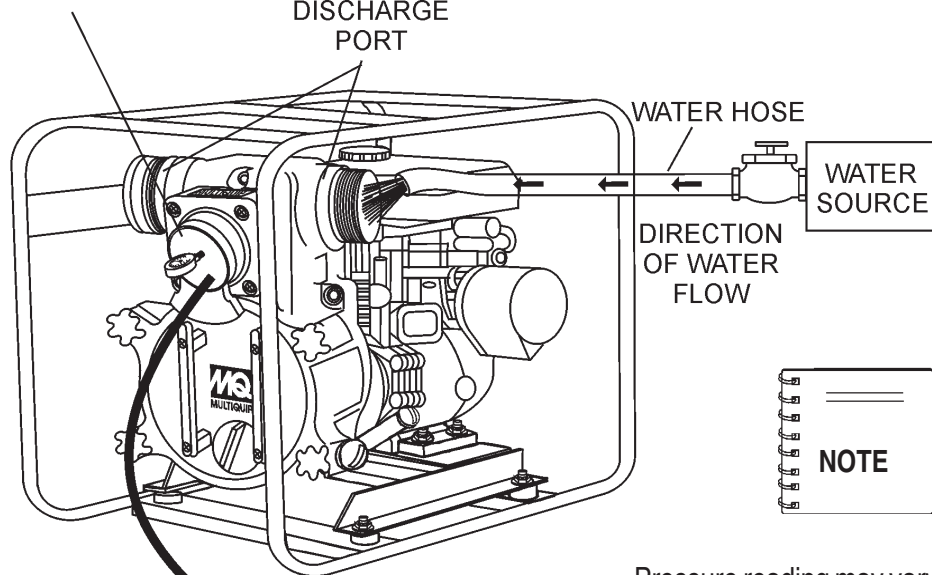

Pressure reading may vary depending on altitude. See Tables 3 and 4 on page 12.

ACCEPTABLE READING SHOULD BE BETWEEN -25 AND -20 IN. HG.

25 IN. HG. TRANSLATES INTO 25 FEET OF LIFT AT SEA LEVEL.

PUMP VACUUM TESTER

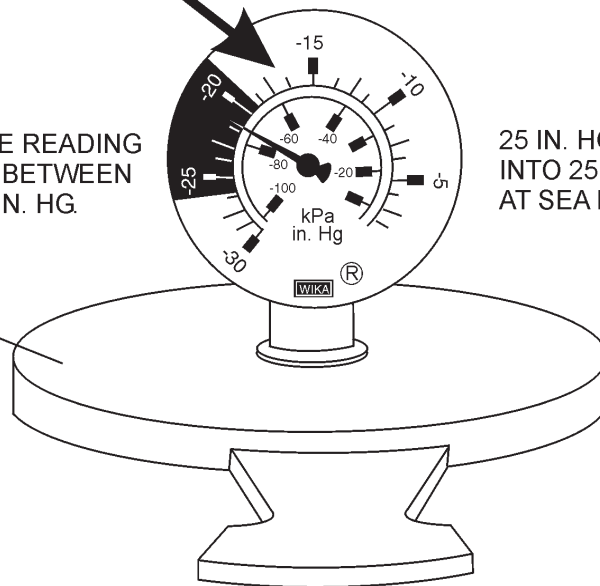

Figure 18. Pump Vacuum Tester

## Engine Maintenance

Perform engine maintenance procedures as referenced by Table 6 below:

Table 6. Engine Maintenance Schedule							
DESCRIPTION (3)	OPERATION	BEFORE	FIRST MONTH OR 10 HRS.	EVERY 3 MONTHS OR 25 HRS.	EVERY 6 MONTHS OR 50 HRS.	EVERY YEAR OR 100 HRS.	EVERY 2 YEARS OR 200 HRS.
Engine Oil	CHECK	X					
	CHANGE		X				
Air Cleaner	CHECK	X					
	CHANGE			X (1)			
All Nuts & Bolts	Re-tighten If Necessary	X					
Spark Plug	CHECK-CLEAN				X		
	REPLACE						X
Cooling Fins	CHECK				X		
Spark Arrester	CLEAN					X	
Fuel Tank	CLEAN					X	
Fuel Filter	CHECK					X	
Idle Speed	CHECK-ADJUST					X (2)	
Valve Clearance	CHECK-ADJUST						X (2)
Fuel lines	CHECK	Every 2 years (replace if necessary) (2)					

(1) Service more frequently when used in **DUSTY** areas.

(2) These items should be serviced by your servic dealer, unless you have the proper tools and are mechanically proficient. Refer to the ROBIN shop Manual for service procedures.

(3) For commercial use, log hours of operation to determine proper maintenance intervals.

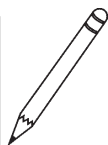
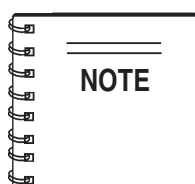

Reference manufacturer engine manual for specific servicing instructions.

## Maintenance

Perform the engine maintenance procedures as indicated below:

### DAILY

- Thoroughly remove dirt and oil from the engine and control area. Clean or replace the air cleaner elements as necessary. Check and retighten all fasteners as necessary. Check the spring box and bellows for oil leaks. Repair or replace as needed.

### WEEKLY

- Remove the fuel filter cap and clean the inside of the fuel tank.
- Remove or clean the filter at the bottom of the tank.
- Remove and clean the spark plug (Figure 19), then adjust the spark gap to 0.028 ~0.031 inch (0.6~0.7 mm). This unit has electronic ignition, which requires no adjustments.

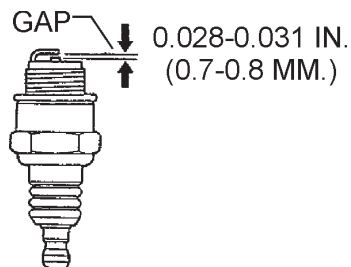

Figure 19. Spark Plug Gap

### ENGINE OIL

1. Drain the engine oil when the oil is **warm** as shown in Figure 20.
2. Remove the oil drain bolt and sealing washer and allow the oil to drain into a suitable container.
3. Replace engine oil with recommended type oil as listed in Table 5. Engine oil capacity is 1.16 quarts (1.1 liters). **DO NOT** overfill.
4. Install drain bolt with sealing washer and tighten securely.

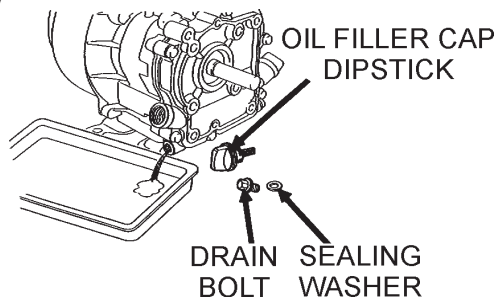

Figure 20. Engine Oil (Draining)

## DANGER

**DO NOT** use gasoline as a cleaning solvent, because that would create a risk of fire or explosion.

### ENGINE AIR CLEANER

1. Remove the air cleaner cover and foam filter element as shown in Figure 21.
2. Tap the paper filter element (Figure 20) several times on a hard surface to remove dirt, or blow compressed air [not exceeding 30 psi (207 kPa, 2.1 kgf/cm<sup>2</sup>)] through the filter element from the air cleaner case side. **NEVER** brush off dirt. Brushing will force dirt into the fibers. Replace the paper filter element if it is excessively dirty.
3. Clean foam element in warm, soapy water or nonflammable solvent. Rinse and dry thoroughly. Dip the element in clean engine oil and completely squeeze out the excess oil from the element before installing.

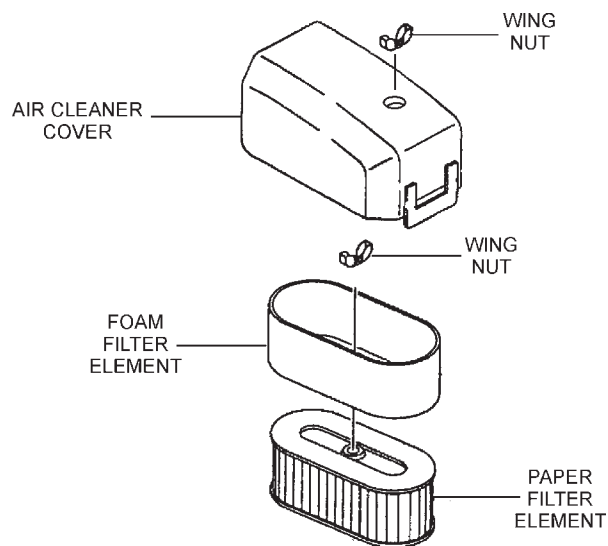

Figure 21. Engine Air Cleaner

### Pump Storage

For storage of the pump for over 30 days, the following is required:

- Drain the fuel tank completely.
- Run the engine until the fuel in the injection system is completely consumed.
- Completely drain used oil from the engine crankcase and fill with fresh clean oil, then follow the procedures described in the engine manual for engine storage.
- Remove the drain plug from the pump and drain out any water left in the housing.
- Remove the pump cover and clean the inside of pump housing. Coat the inside of pump housing with a light film of oil to reduce corrosion. A spray can of oil works well for this application.
- Cover suction and discharge ports with duct tape to prevent any foreign matter from falling into pump.
- Cover pump and engine with plastic covering or equivalent and store in a clean, dry place.
- To protect the water cooled-seals, place one-half pint of lubricating oil (new or used) through the discharge opening on the pump and crank the engine several times. This will prevent excessive corrosion and also keep the mechanical seal lubricated.



# QP- 2TE — TROUBLESHOOTING (ENGINE)

**TABLE 7. ENGINE TROUBLESHOOTING**

SYMPTOM	POSSIBLE PROBLEM	SOLUTION
<b>Difficult to start</b>		
Fuel is available but spark plug will not ignite. (Power available at high tension cable).	Ignition plug being bridge?	Check ignition system.
	Carbon deposit at ignition?	Clean or replace ignition.
	Short circuit due to defective insulators?	Replace insulators.
	Improper spark gap?	Set spark plug gap to the correct gap.
Fuel is available but spark plug will not ignite. (Power <b>NOT</b> available at high tension cable).	Short circuit at stop switch?	Check stop switch circuit. Replace stop switch if defective.
	Ignition coil defective?	Replace ignition coil.
Fuel is available and spark plug ignites (compression <b>normal</b> ).	Muffler clogged with carbon deposits?	Clean or replace muffler.
	Mixed fuel quality is inadequate?	Check fuel to oil mixture.
	Fuel in use inadequate (water, dust)?	Flush fuel sytem and replace with fresh fuel.
	Air Cleaner clogged?	Clean or replace air cleaner.
Fuel is available and spark plug ignites (compression <b>low</b> ).	Defective cylinder head gasket?	Tighten cylinder head bolts or replace head gasket.
	Cylinder worn?	Replace cylinder.
	Spark plug loose?	Tighen spark plug.
<b>Operation not satisfactory</b>		
Not enough power available (compression normal, no miss-firing).	Air cleaner clogged?	Clean or replace air cleaner.
	Air in fuel line?	Bleed (remove air) from fuel line.
	Fuel level in carbureator float chamber improper?	Adjust carbureator float
	Carbon deposits in cylinder?	Clean or replace cylinder
Not enough power available (compression normal, miss-firing).	Ignition coil defective?	Flush fuel sytem and replace with fresh fuel.
	Ignition plug often shorts?	Replace ignition wires, clean ignition.
	Fuel in use inadequate (water, dust)?	Flush fuel sytem and replace with fresh fuel.
Engine overheats.	Excessive carbon depostion in combustion chamber?	Clean or replace crankcase.
	Exhaust or muffler clogged with carbon.	Clean or replace muffler.
	Spark plug heat value incorrect?	Replace spark plug with correct type spark plug.

# QP-2TE — TROUBLESHOOTING (ENGINE/PUMP)

**TABLE 7. ENGINE TROUBLESHOOTING (Continued)**

SYMPTOM	POSSIBLE PROBLEM	SOLUTION
<b>Operation not satisfactory</b>		
Rotational speed fluctuates.	Governor adjustment improper?	Adjust governor to correct lever.
	Governor spring defective?	Clean or replace ignition.
	Fuel flow erratic?	Check fuel line.
	Air taken in through suction line?	Check suction line.
Recoil starter not working properly.	Dust in rotating part?	Clean recoil starter assembly.
	Spring spring failure?	Replace spiral spring.

**TABLE 8. PUMP TROUBLESHOOTING**

SYMPTOM	POSSIBLE PROBLEM	SOLUTION
Pump does not take on water.	Not enough priming water in the housing?	Add water.
	Engine speed too low?	Increase throttle.
	Strainer plugged?	Clean strainer.
	Suction hose damaged?	Replace or repair hose, and clamps
	Air leak at suction port?	Check that fittings are tight and properly sealed.
	Pump is located too high above water line?	Move pump closer to water.
	Debris collecting in pump housing?	Clean pump housing.
	Too much distance between impeller and volute.	Adjust clearance by adding shims or replace impeller. Min. .006" - Max. .020"
	Water leaking out weep hole between pump and engine?	Check condition of mechanical seal and gaskets, between pump end and engine housing.
Pump takes in water, little or no discharge.	Engine speed too low?	Increase throttle speed.
	Suction strainer partially plugged?	Clean strainer.
	Impeller/Volute worn?	Adjust clearance by adding shims or replace impeller/volute
Suction hose leaks at inlet.	Fittings/clamps are not sealed properly?	Tighten, replace or add clamp. (Keep extra seals on pump)
	Hose diameter is too large?	Use smaller diameter hose or replace hose.
Discharge does not stay on coupling.	Pressure too high?	Check pressure, add additional clamp.
	Hose kinked or end blocked?	Check hose.
Impeller does not turn: pump is hard to start.	Impeller jammed or blocked?	Open pump cover and clean dirt and debris from inside housing.
	Impeller and volute binding?	Adjust clearance by removing shim from behind impeller.
	Defective engine?	See Engine Owner's Manual.

# QP- 2TE — EXPLANATION OF CODE IN REMARKS COLUMN

How to read the marks and remarks used in this parts book.

## Items Found In the “Remarks” Column

**Serial Numbers**-Where indicated, this indicates a serial number range (inclusive) where a particular part is used.

**Model Number**-Where indicated, this shows that the corresponding part is utilized only with this specific model number or model number variant.

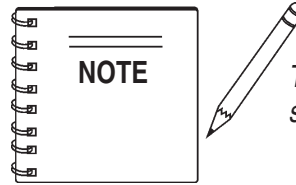

*The contents of this catalog are subject to change without notice.*

## Items Found In the “Items Number” Column

All parts with same symbol in the number column, \*, #, +, %, or ■, belong to the same assembly or kit.

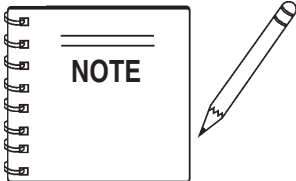

If more than one of the same reference number is listed, the last one listed indicates newest (or latest) part available.

## QP- 2TE TRASH PUMP 1 TO 3 UNITS W/ROBIN EX170D50021 ENGINE

Qty.	P/N	Description
2	.....	KIT, MECHANICAL SEAL, O-RINGS
1	1889040030	..... IMPELLER
2	0631211159	..... FLOODING CAP, W/ O-RING
3	0650140150	..... SPARK PLUG
3	2773261107	..... ELEMENT, AIR CLEANER
1	5825011118	..... ROPE STARTER
1	0430440050	..... CAP, FUEL TANK
1	0641360010	..... FUEL FILTER, GAS TANK

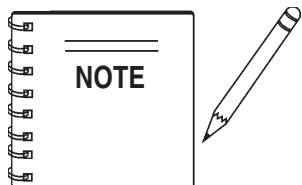

Part number on this Suggested Spare Parts List may supersede/replace the P/N shown in the text pages of this book.

# QP-2TE — PUMP ASSY.

PUMP ASSY.

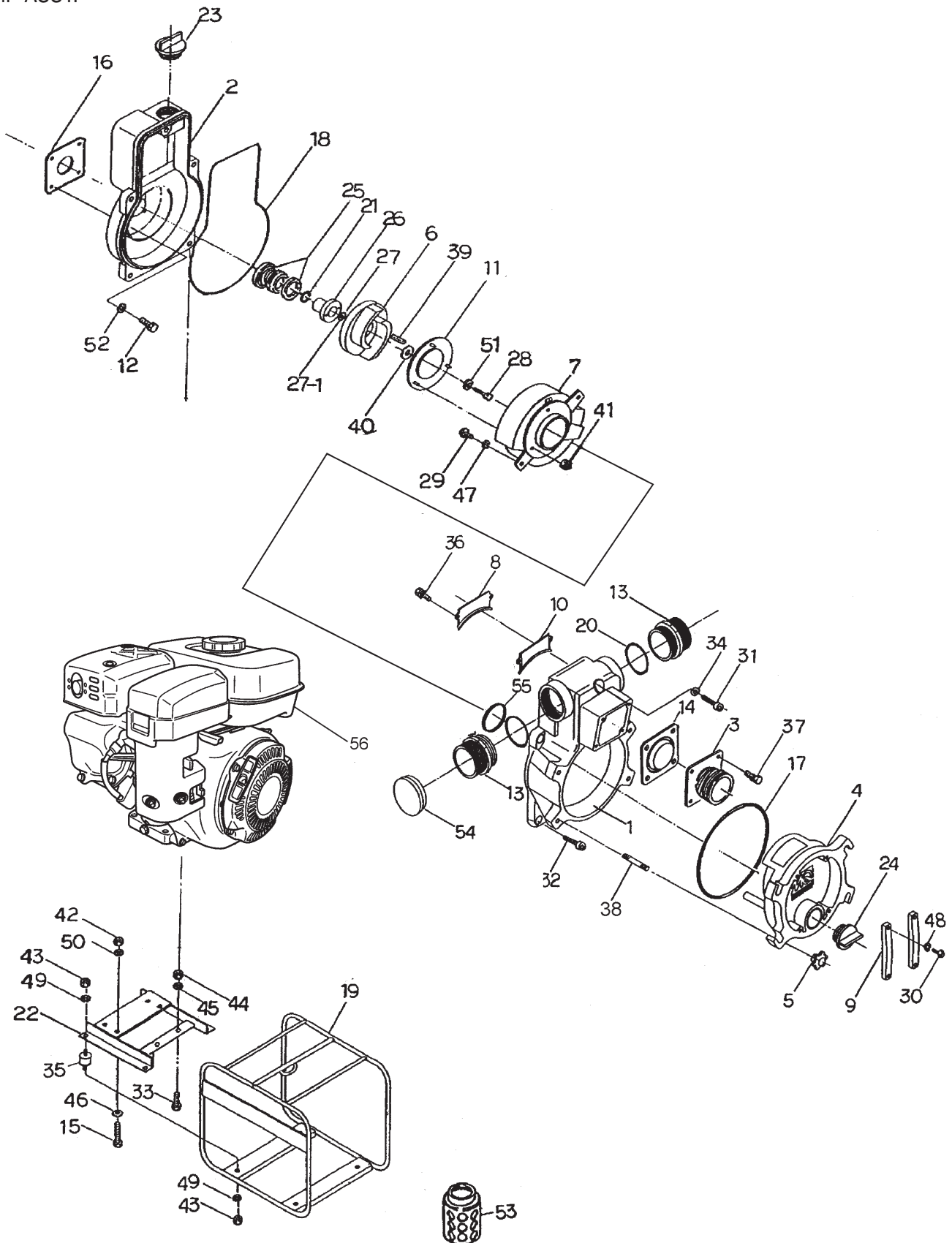

PUMP ASSY.

<u>NO.</u>	<u>PART NO.</u>	<u>PART NAME</u>	<u>QTY.</u>	<u>REMARKS</u>
1	1889100011	CASING	1	
2	1889100020	CASING COVER	1	
3	18890001600014	SUCTION COVER	1	
4	1889100171	DRAIN COVER	1	
5	19920002200014	DRAIN COVER HANDLE	4	
6	1889040030	IMPELLER	1	
7	1889000132	VOLUTE CASING	1	
8	1889100741	SUCTION PLATE	1	
9	1247100250	DRAIN COVER SET HANDLE	2	
10	1889330410	SUCTION PLATE PACKING	1	
11	1992250700	WEAR PLATE	1	
12	0191190525	BOLT(CASING COVER), 5/16-24UNF X 25	4	
13	07904320200014	NIPPLE, NPS2" X NPT2"	2	
14	1889350351	CHECK VALVE, NBR+SS400	1	
15	0105090840	BOLT(ENGINE), M8 X 40	4	
16	1211390610	CASING COVER PACKING, OIL SHEET, X 84	1	
17*	0481571950	O'RING (DRAIN COVER), G195	1	
18*	0489402910	O'RING (CASING)	1	
19	1889214010P002	BASE, SS400	1	
20	0481310550	O'RING (NIPPLE), G55	2	
21*	0482200180	O'RING (MECHANICAL SEAL SLEEVE), S18	1	
22	18892140200014	ENGINE BASE, SS400	1	
23	0631211159	FLOODING CAP, PF1 1/2"	1	
24	0631211159	DRAIN CAP, PF1 1/2"	1	
25*	0803442930	MECHANICAL SEAL, EH791-030-T, SIC X SIC	1	
26*	0811345443	MECHANICAL SEAL SLEEVE, 25 H43	1	
27*	0852833020	ADJUST LINER, 30 X 20 T0.3, Bs.P	1	
27-1*	0852853020	ADJUST LINER, 30 X 20 T0.5, Bs.P	1	
28	0191190525	BOLT(IMPELLER), 5/16-24UNF X 25	1	
29	0141090820	SCREW (VOLUTE CASING), M8 X 20	2	
30	0141090825	SCREW (DRAIN COVER SET HANDLE), M8 X 25	4	
31	0131191270	CAP SCREW (CASING), M12 X 70	1	
32	0131191235	CAP SCREW (CASING), M12 X 35	4	
33	0105091035	BOLT (PUMP),M10 X 35	2	
34	0459220120	SEAL WASHER(CASING), M12, W12S1	1	
35	0723302040	CUSHION RUBBER, 40 X 20 M10, NBR+SS400	4	
36	0181090820	BOLT SET WITH SPRING WASHER (SUCTION COVER)M8 X 20	2	
37	0181090825	BOLT SET WITH SPRING WASHER (SUCTION COVER)M8 X 25	4	

# QP-2TE — PUMP ASSY.

PUMP ASSY.

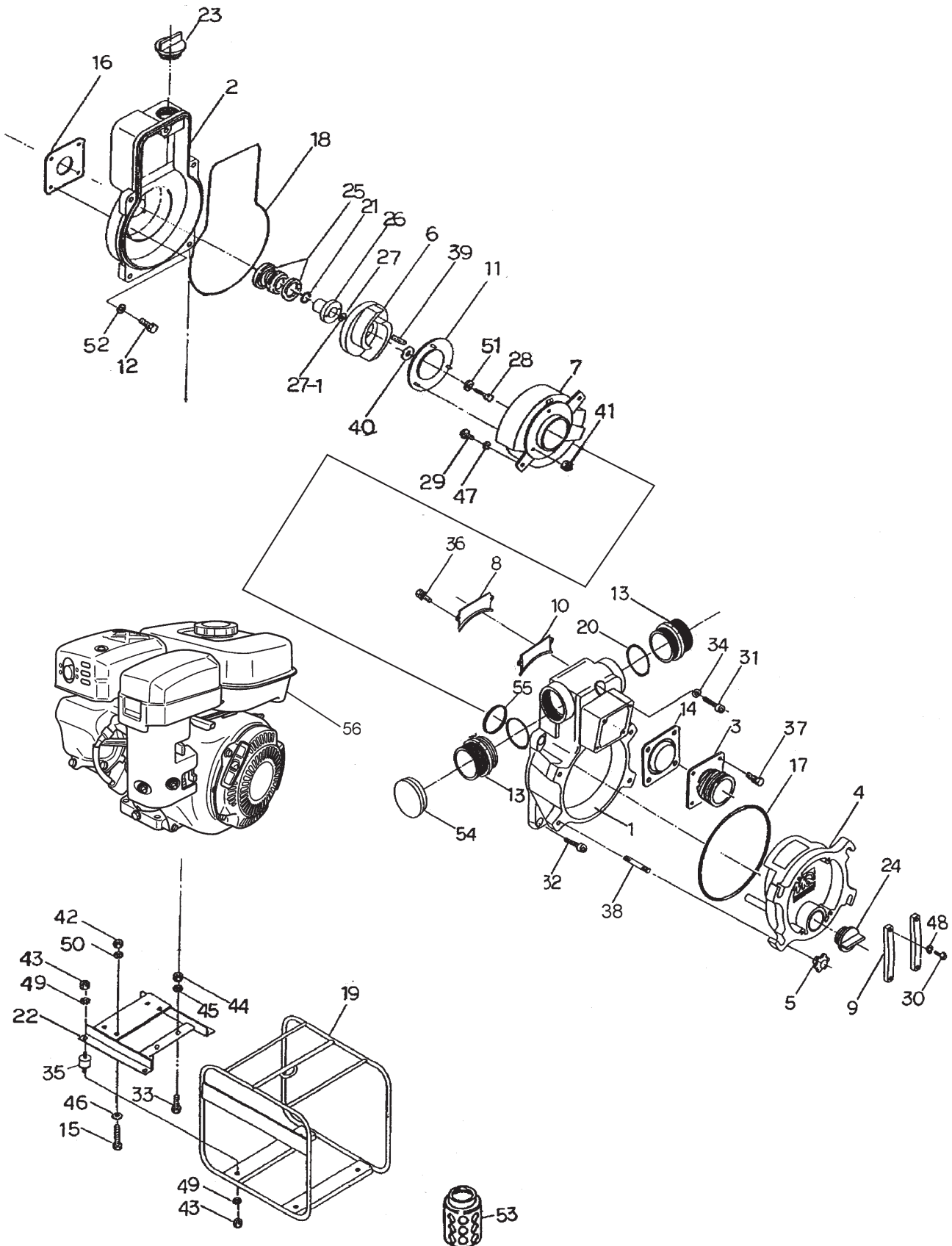

PUMP ASSY. (cont.)

<u>NO.</u>	<u>PART NO.</u>	<u>PART NAME</u>	<u>QTY.</u>	<u>REMARKS</u>
38	0151191257	STUD BOLT (DRAIN COVER HANDLE), X 4.7X16	4	
39	0520030413	KEY,12 X 50 X 15 X 20, S45C	1	
40	43592012400011	IMPELLER WASHER, f <sup>335</sup> X f <sup>39</sup> T4.5	1	
41	0204490060	U-NUT(WEAR PLATE, M6	3	
42	0205490080	NUT, ENGINE, M8	4	
43	0205490100	NUT, CUSHION RUBBER, M10	8	
44	0205490100	NUT, PUMP, M10	2	
45	0451290100	SPRING WASHER, PUMP, M10	2	
46	0401650080	WASHER, ENGINE, M8	4	
47	0457290080	SPRING WASHER (VOLUTE CASING), M8	2	
48	0451290080	SPRING WASHER“(DRAIN COVER SET, M8	4	
49	0451290100	SPRING WASHER (CUSHION RUBBER), M10	8	
50	0451290080	SPRING WASHER (ENGINE), M8	4	
51	0451290080	SPRING WASHER (IMPELLER), M8	1	
52	0742214050	SPRING WASHER“(CASING COVER ), M8	4	
53	0742214050	STRAINER, NPT	1	
54	1889068050	CAP	1	
55	0741310700	O’RING, G70	1	
56	EX170D50021	ENGINE, ROBIN KIT, MECHANICAL SEAL, O-RINGS	1	INCLUDES ITEMS W/ *

# ROBIN EX170D50021 ENGINE— CRANKCASE ASSY.

## CRANKCASE ASSY.

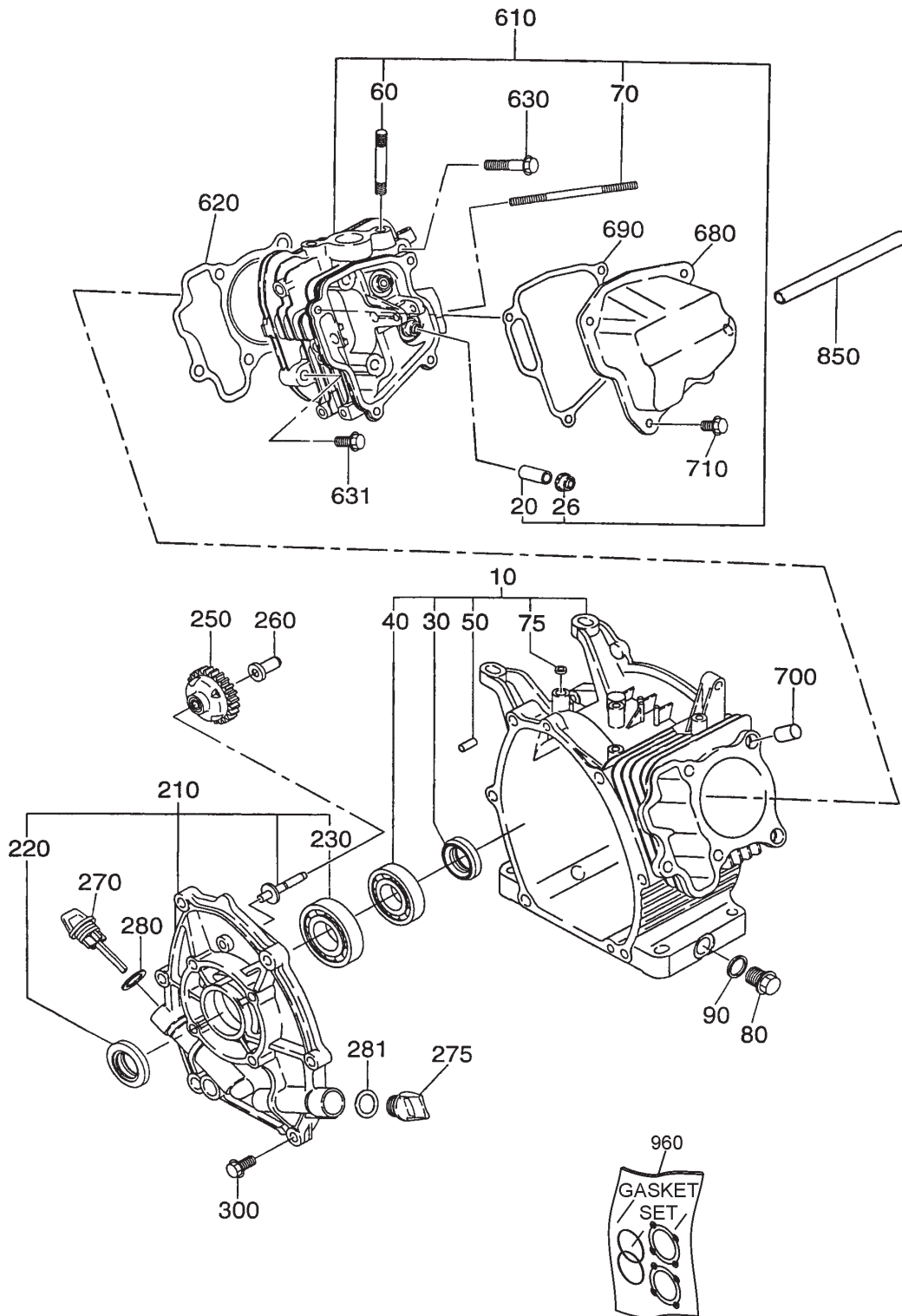

# ROBIN EX170D50021 ENGINE— CRANKCASE ASSY.

## CRANKCASE ASSY.

<u>NO</u>	<u>PART NO</u>	<u>PART NAME</u>	<u>QTY.</u>	<u>REMARKS</u>
10	2771010241	CRANKCASE CP .....	1 .....	INCLUDES ITEMS W/ *
20#	2371420103	VALVE GUIDE	2	
26#	2771601001	STEM SEAL	1	
30*	0440250200	OIL SEAL	1	
40*	0600280021	BALL BEARING	1	
50*	2771501103	PIPE KNOCK	2	
60#	0105080250	STUD	2	
70#	0105060351	STUD	2	
75*	0440060020	OIL SEAL	1	
80	0401140030	PLUG	2	
90+	0211140020	GASKET	2	
210	2771100131	MAIN BEARING COVER C .....	1 .....	INCLUDES ITEMS W/ %
220%	0440250210	OIL SEAL	1	
230%	0600250140	BALL BEARING, 6205	1	
250	2774500141	GOVERNOR GEAR CP	1	
260	2774190103	GOVERNOR SLEEVE	1	
270	2776360113	OIL GAUGE	1	
275	2776500103	FILLER PLUG	1	
280+	0213160020	GASKET	1	
281	0213160020	GASKET	1	
300	0010408350	FLANGE BOLT	6	
610	2771300111	CYLINDER HEAD CP .....	1 .....	INCLUDES ITEMS W/ #
620+	2771500123	GASKET, HEAD	1	
630	0110080240	FLANGE BOLT	4	
631	0010408350	FLANGE BOLT	1	
680	2771550101	ROCKER COVER CP	1	
690+	2771600103	GASKET, ROCKER COVER	1	
700	2771501103	PIPE KNOCK	2	
710	0110060020	FLANGE BOLT	4	
850	0851080000	RUBBER PIPE	1	
960	2779900107	GASKET SET .....	1 .....	INCLUDES ITEMS W/ + & ITEM 340 OF INTAKE AND EXHAUST ASSY.

# ROBIN EX170D50021 ENGINE— CRANKSHAFT AND PISTON ASSY.

CRANKSHAFT AND PISTON ASSY.

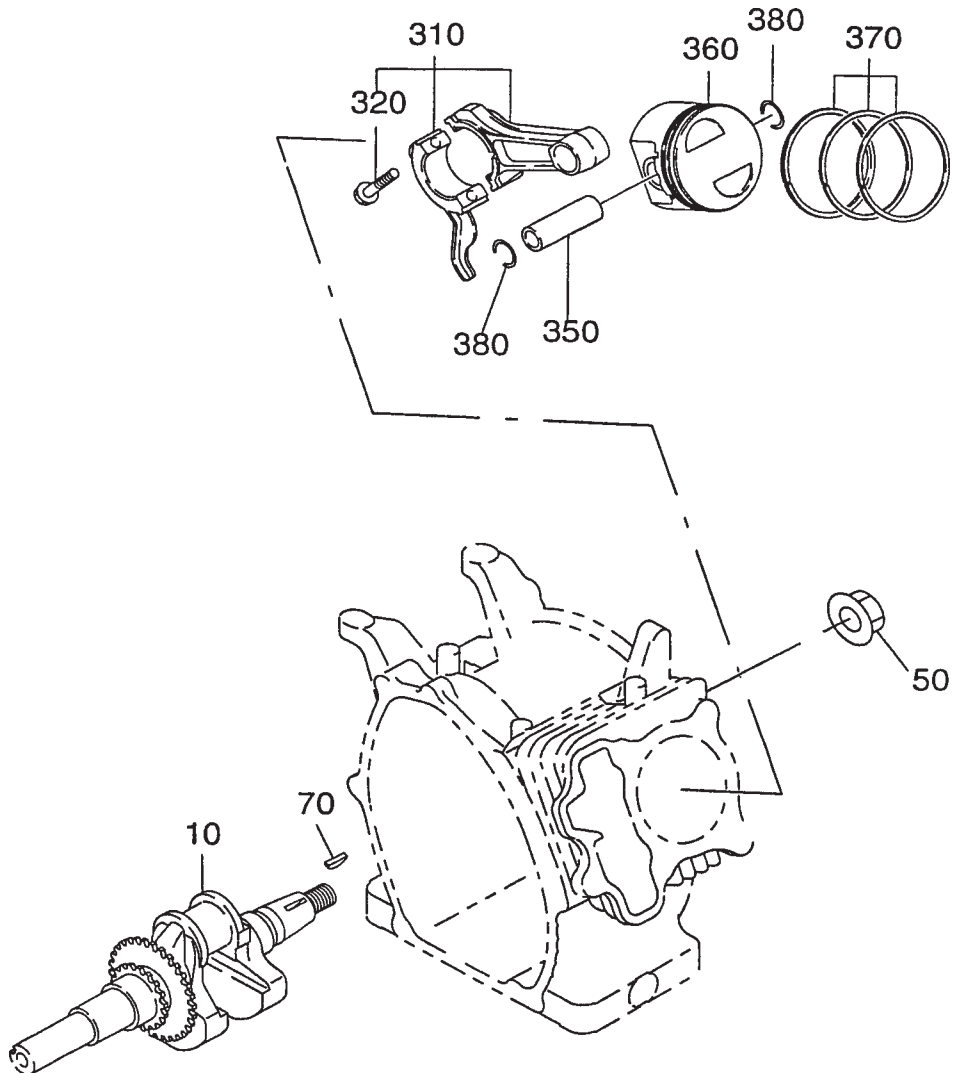

# ROBIN EX170D50021 ENGINE— CRANKSHAFT AND PISTON ASSY.

## CRANKSHAFT AND PISTON ASSY.

<u>NO</u>	<u>PART NO</u>	<u>PART NAME</u>	<u>QTY.</u>	<u>REMARKS</u>
10	2772030121	CRANKSHAFT CP	1	
50	0180140020	FLANGE NUT	1	
70	0323030010	WOODRUFF KEY	1	
310	2772250110	CONNECTING ROD ASSY. ....	1	INCLUDES ITEMS W/*
320*	2772300103	CONNECTING ROD BOLT	2	
350	2772330103	PISTON PIN	1	
360	2772340103	PISTON	1	
360	2772340303	PISTON, OVERSIZE 0.25 MM	1	
360	2772340403	PISTON, OVERSIZE 0.50 MM	1	
370	2772351107	PISTON RING SET	1	
370	2772351217	PISTON RING SET, OVERSIZE 0.25 MM	1	
370	2772351317	PISTON RING SET, OVERSIZE 0.50 MM	1	
380	0565160010	CLIP	2	

# ROBIN EX170D50021 ENGINE— GOVERNOR ASSY.

GOVERNOR ASSY.

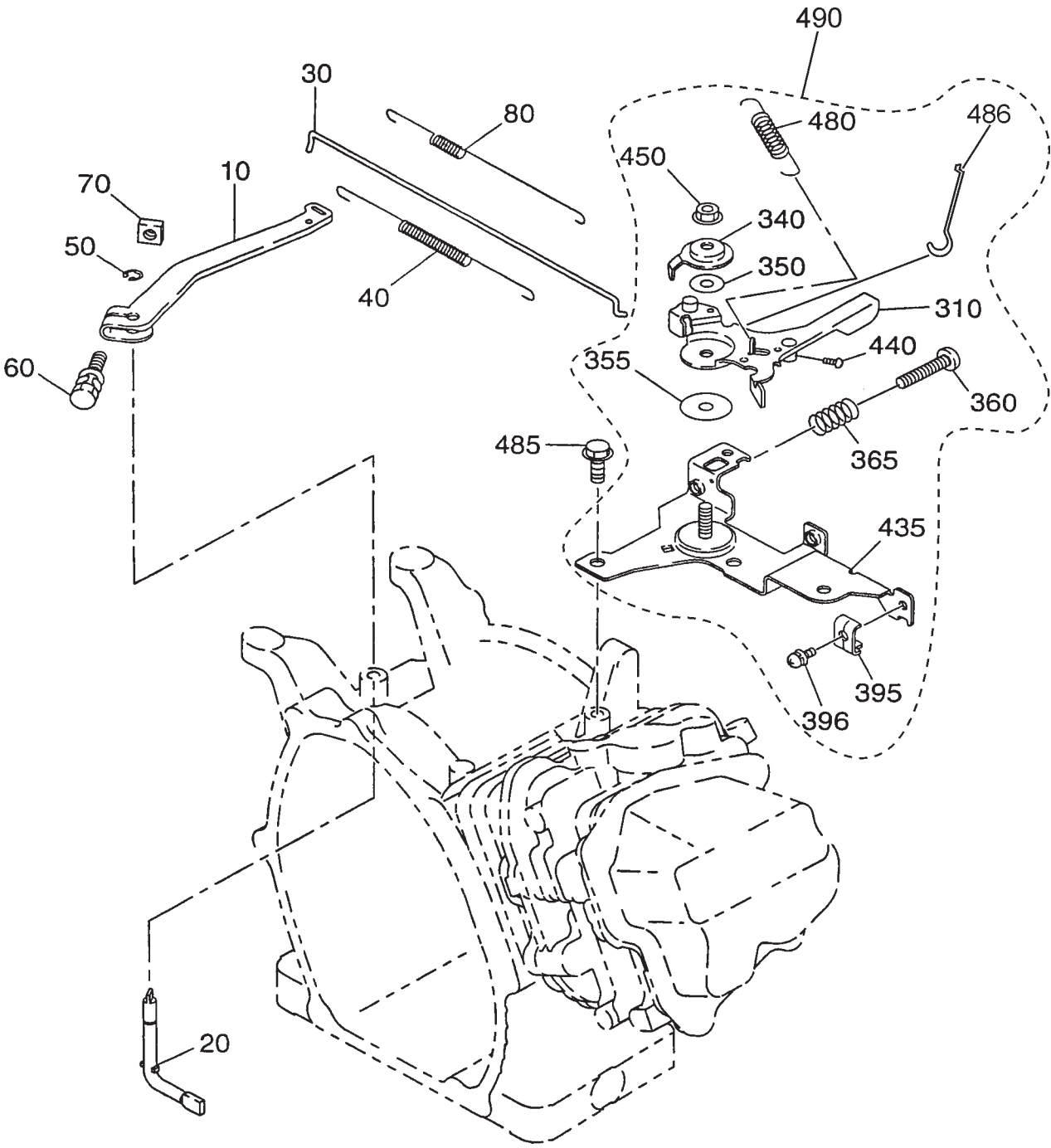

# ROBIN EX170D50021 ENGINE— GOVERNOR ASSY.

## GOVERNOR ASSY.

<u>NO</u>	<u>PART NO</u>	<u>PART NAME</u>	<u>QTY.</u>	<u>REMARKS</u>
10	2774230113	GOVERNOR LEVER	1	
20	2774220133	GOVERNOR SHAFT	1	
30	2774270101	GOVERNOR ROD CP	1	
40	2774280113	ROD SPRING	1	
50	0031305000	CLIP	1	
60	0130060240	BOLT & WASHER ASSY.	1	
70	0186060020	NUT	1	
80	2794250223	GOVERNOR SPRING	1	
80	2764250533	GOVERNOR SPRING	1	
310*	2774330301	SPEED CONTROL LEVER	1	
340*	2774350103	STOP PLATE	1	
350*	0200060170	WASHER	1	
355*	0217060070	FRICTION, WASHER	1	
360*	0043106250	SCREW	1	
365*	2374500423	SPRING, ADJUST	1	
395*	2774390203	CLAMP	1	
396*	0131050030	SCREW & WASHER ASSY.	1	
435*		SPEED CONT. BRKT CP .....	1	..... CAN ONLY BE PURCHASED W/ITEM 490
440*	0043104080	SCREW	1	
450*	0023506000	SELF LOCK NUT	1	
480*	674510103	RETURN SPRING	1	
485	0110060020	FLANGE BOLT	2	
486*	2774370101	LINK ROD	1	
490	2774600210	SPEED CONTROL ASSY. ....	1	..... INCLUDES ITEMS W/*

# ROBIN EX170D50021 ENGINE— INTAKE EXHAUST ASSY.

INTAKE AND EXHAUST GROUP ASSY.

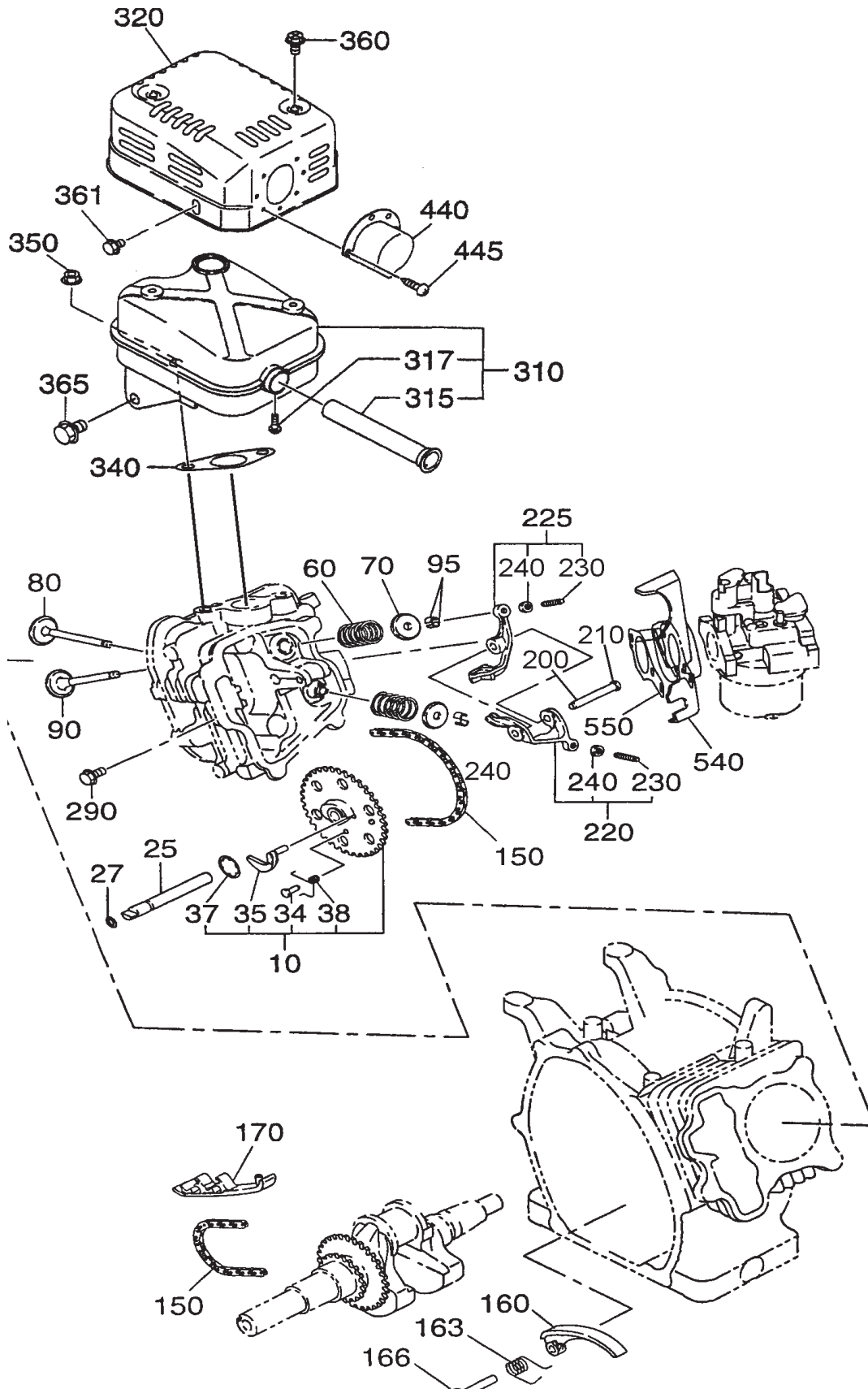

# ROBIN EX170D50021 ENGINE— INTAKE EXHAUST ASSY.

## INTAKE AND EXHAUST ASSY.

<u>NO</u>	<u>PART NO</u>	<u>PART NAME</u>	<u>QTY.</u>	<u>REMARKS</u>
10	2773160111	CAM SHAFT CP .....	1	INCLUDES ITEMS W/%
25	2773510103	PIN, CAM SHAFT	1	
27	0240060010	O-RING	1	
34%	2773860103	PIN, SPRING	1	
35%	2773640103	RELEASE LEVER	1	
37%	2773650103	CLIP	1	
38%	2773870203	RETURN SPRING	1	
60	2793360103	VALVE SPRING	2	
70	2693370103	SPRING RETAINER	2	
80	2773340113	INTAKE VALVE	1	
90	2773350113	EXHAUST VALVE	1	
95	13210KA031	COLLET VALVE	4	
150	2773560111	TIMING CHAIN CP	1	
160	2773691103	TENTIONER	1	
163	2773710103	SPRING, TENTIONER	1	
166	2773690203	PIN, TENTIONER	1	
170	2773691313	CHAIN GUIDE	1	
200	2773500203	PIN, ROCKER	1	
210	0031305000	CLIP	1	
220	2773620100	ROCKER ARM, IN, ASSY. ....	1	INCLUDES ITEM W/+
225	2773620200	ROCKER ARM, EX, ASSY. ....	1	INCLUDES ITEM W/+
230+	0149050020	ADJUST SCREW	1	
240+	0170050020	NUT	1	
290	0110060020	FLANGE BOLT	1	
310	2773011101	MUFFLER/SPARK ARRESTOR .....	1	INCLUDES ITEMS W/*
315*	2773760101	SPARK ARRESTOR	1	
317*	0150040060	TAPPING SCREW	1	
320	2773240111	MUFFLER COVER CP	1	
340	2773520113	GASKET, MUFFLER	1	
350	9802008280	FLANGE NUT	2	
360	0152060090	TAPPING BOLT	2	
361	0110060010	FLANGE BOLT	1	
365	0110080150	FLANGE BOLT	1	
440	2773700103	DEFLECTOR	1	
445	0150040060	TAPPING SCREW	2	
540	2773290113	INSULATOR	1	
550	2773590113	GASKET, INSULATOR	1	

# ROBIN EX170D50021 ENGINE — AIR CLEANER ASSY.

AIR CLEANER ASSY.

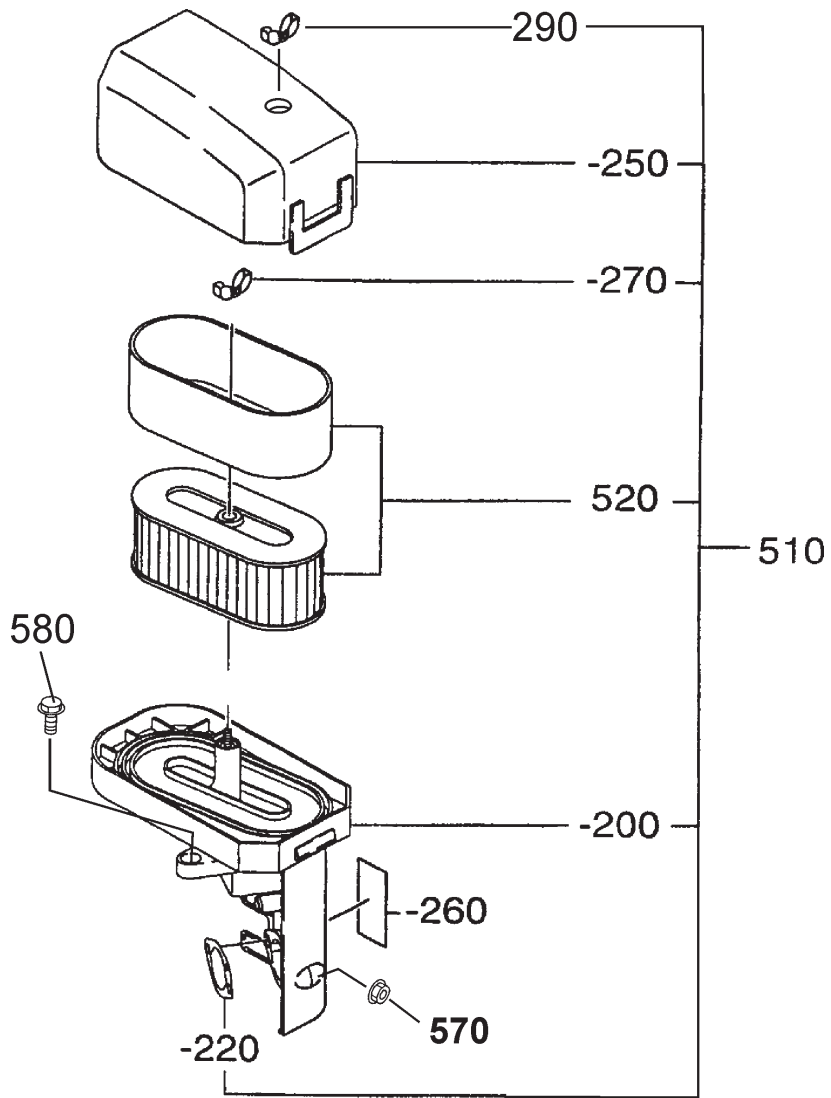

# ROBIN EX170D50021 ENGINE — AIR CLEANER ASSY.

## AIR CLEANER ASSY.

<u>NO.</u>	<u>PART NO.</u>	<u>PART NAME</u>	<u>QTY.</u>	<u>REMARKS</u>
510	2773261500	AIR CLEANER ASSY., DUAL	1	INCLUDES ITEMS W/ *
510-200*	2773263008	BASE CP	1	
510-220	2773260408	PACKING	1	
510-250*	2773264008	COVER CP	1	
510-260	2773260908	LABEL	1	
510-270	2773274108	WING NUT	1	
510-290	2773274008	WING NUT	1	
510-520	2773261107	ELEMENT ASSY, DUAL	1	
570	0023806000	FLANGE NUT	2	
580	0110060050	FLANGE BOLT	2	

# ROBIN EX170D50021 ENGINE — COOLING AND STARTING ASSY.

COOLING AND STARTING ASSY.

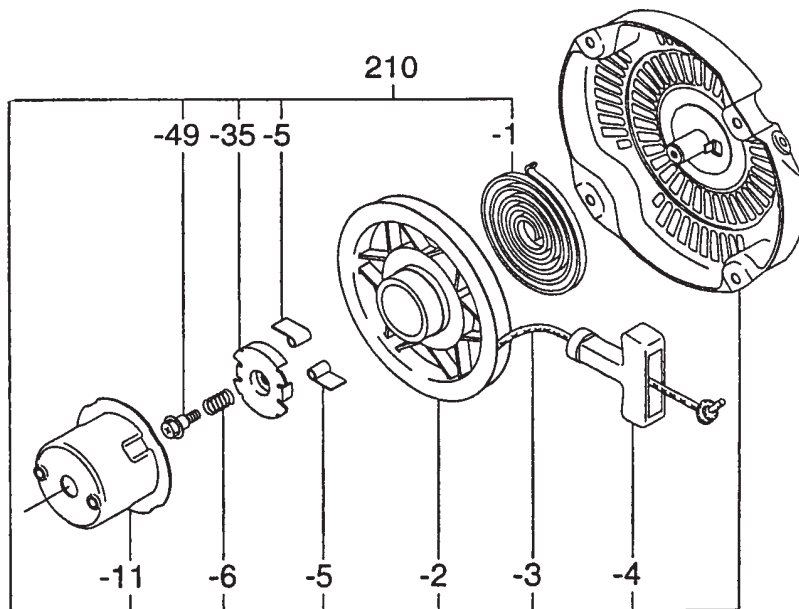
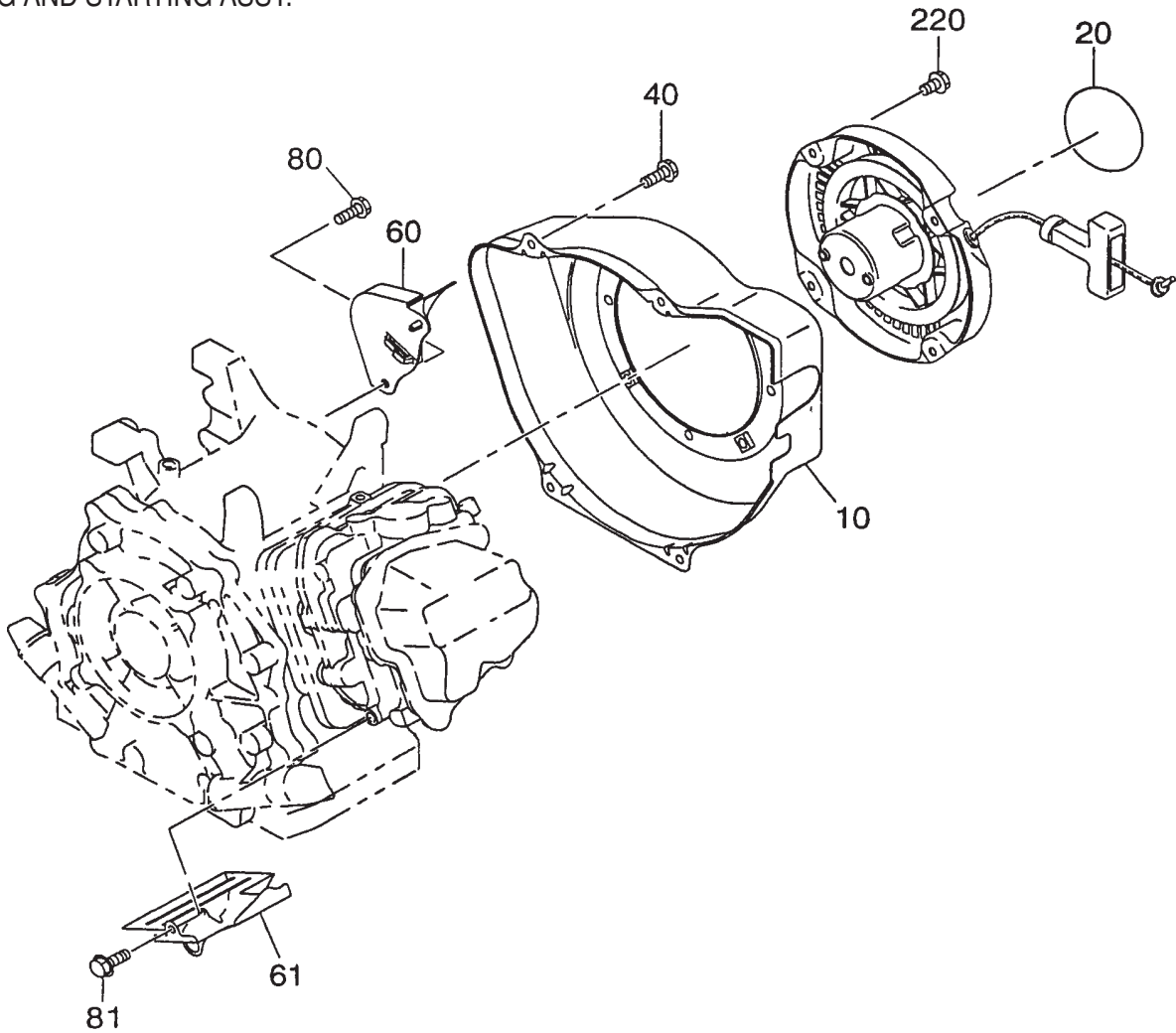

# ROBIN EX170D50021 ENGINE— COOLING AND STARTING ASSY.

## COOLING AND STARTING ASSY.

<u>NO</u>	<u>PART NO</u>	<u>PART NAME</u>	<u>QTY.</u>	<u>REMARKS</u>
10	2775120201	BLOWER HOUSING CP, BLACK	1	
20	0732005140	LABEL, TRADEMARK	1	
40	0110060030	FLANGE BOLT	4	
60	2775271111	BAFFLE 1, CASE CP	1	
61	2775270203	BAFFLE 2, HEAD	1	
80	0010406160	FLANGE BOLT	1	
81	0110060020	FLANGE BOLT	1	
210	2695020130	RECOIL STARTER ASSY. ....	1	INCLUDES ITEM W/*
210-1*	2705011508	SPIRAL SPRING	1	
210-2*	2695012008	REEL	1	
210-3*	5825011118	STARTER ROPE	1	
210-4*	2615010008	STARTER KNOB	1	
210-5*	2705012508	RATCHET	2	
210-6*	2275013108	FRICTION SPRING	1	
210-11*	2695014518	STARTER PULLEY	1	
210-35*	2705026108	RATCHET GUIDE	1	
210-49*	2275015208	SET SCREW	1	
220	0110060010	FLANGE BOLT	4	

**ROBIN EX170D50021 ENGINE — CARBURETOR ASSY.**

CARBURETOR ASSY.

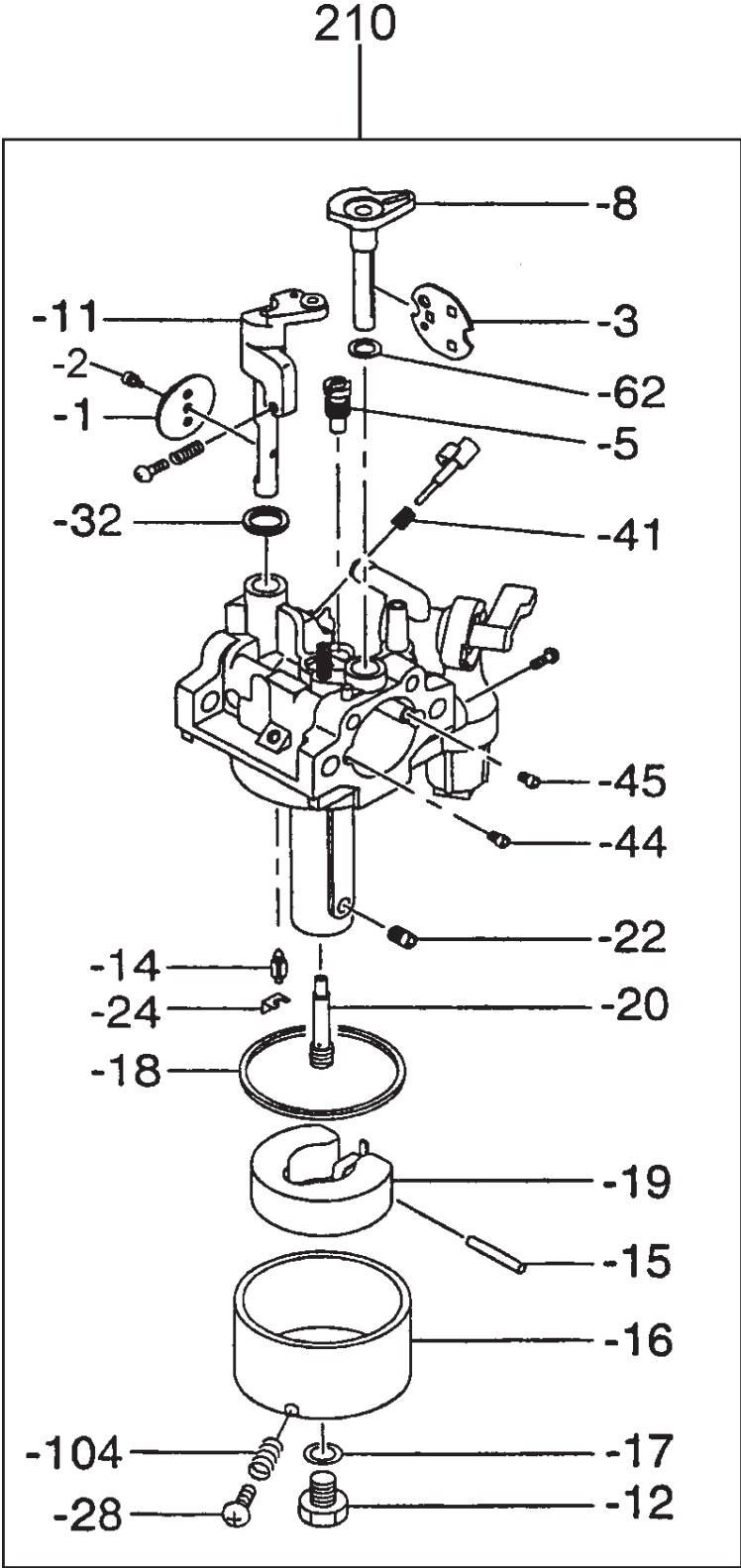

# ROBIN EX170D50021 ENGINE — CARBURETOR ASSY.

## CARBURETOR ASSY.

<u>NO</u>	<u>PART NO</u>	<u>PART NAME</u>	<u>QTY.</u>	<u>REMARKS</u>
210	2776230210	CARBURETOR ASSY. ....	1	INCLUDES ITEM W/*
210-1*	2776253508	THROTTLE VALVE	1	
210-2*	2096235108	THROTTLE SCREW	1	
210-3*	2776252508	CHOKE VALVE	1	
210-5*	2466242008	PILOT JET, #40	1	
210-8*	2776252008	CHOKE LEVER	1	
210-11*	2776253108	THROTTLE SHAFT	1	
210-12*	2276245108	BOLT	1	
210-14*	2776250008	NEEDLE	1	
210-15*	2776251508	PIN	1	
210-16*	2776250608	FLOAT BODY	1	
210-17*	2146245008	PACKING	1	
210-18*	2146254008	CHAMBER PACKING	1	
210-19*	2266250608	FLOAT ASSY.	1	
210-20*	2776244008	MAIN NOZZLE	1	
210-22*	2266241208	MAIN JET	1	
210-24*	2266270118	CLIP	1	
210-28*	2776236008	BOLT	1	
210-32*	2466239008	SEAL	1	
210-44*	2486241008	AIR JET	1	
210-45*	1066241008	AIR JET, PILOT	1	
210-62*	2366268008	SEAL	1	
210-104*	2366254108	PACKING	1	

# ROBIN EX170D50021 ENGINE — FLYWHEEL ASSY.

FLYWHEEL ASSY.

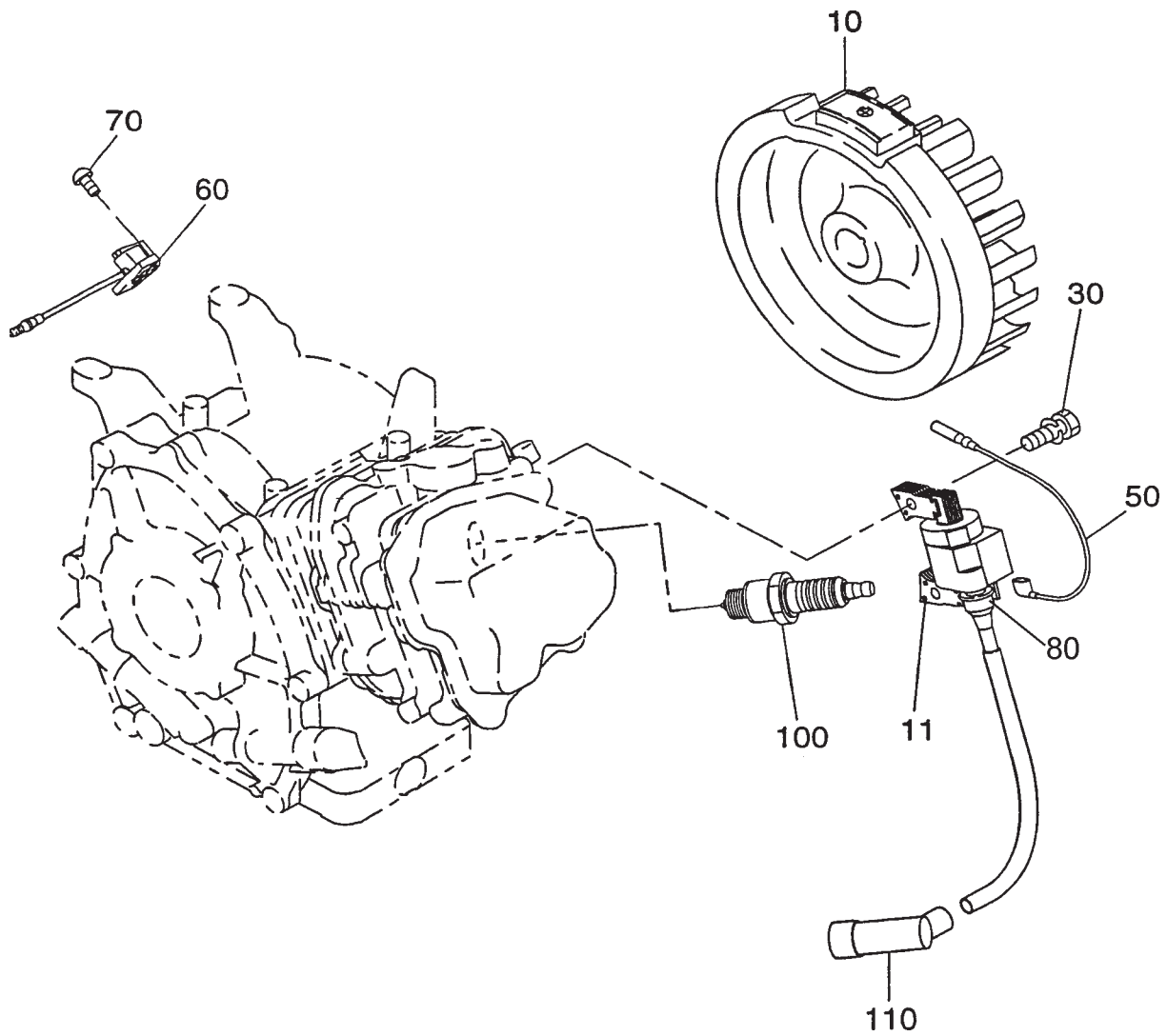

# ROBIN EX170D50021 ENGINE — FLYWHEEL ASSY.

FLYWHEEL ASSY.

<u>NO</u>	<u>PART NO</u>	<u>PART NAME</u>	<u>QTY.</u>	<u>REMARKS</u>
10	2777923011	FLYWHEEL CP	1	
11	2777943101	IGNITION COIL CP	1	
30	0011406250	BOLT & WASHER	2	
50	27773101H1	WIRE 1 CP	1	
60	X660000361	SWITCH ASSY.	1	
70	0150040090	TAPPING SCREW	2	
80	0241070110	GROMMET	1	
100	0650140150	SPARK PLUG .....	1 .....	NGK BR6HS
110	0655000270	SPARK PLUG CAP	1	

**ROBIN EX170D50021 ENGINE— ELECTRIC DEVICE ASSY.**

ELECTRIC DEVICE ASSY.

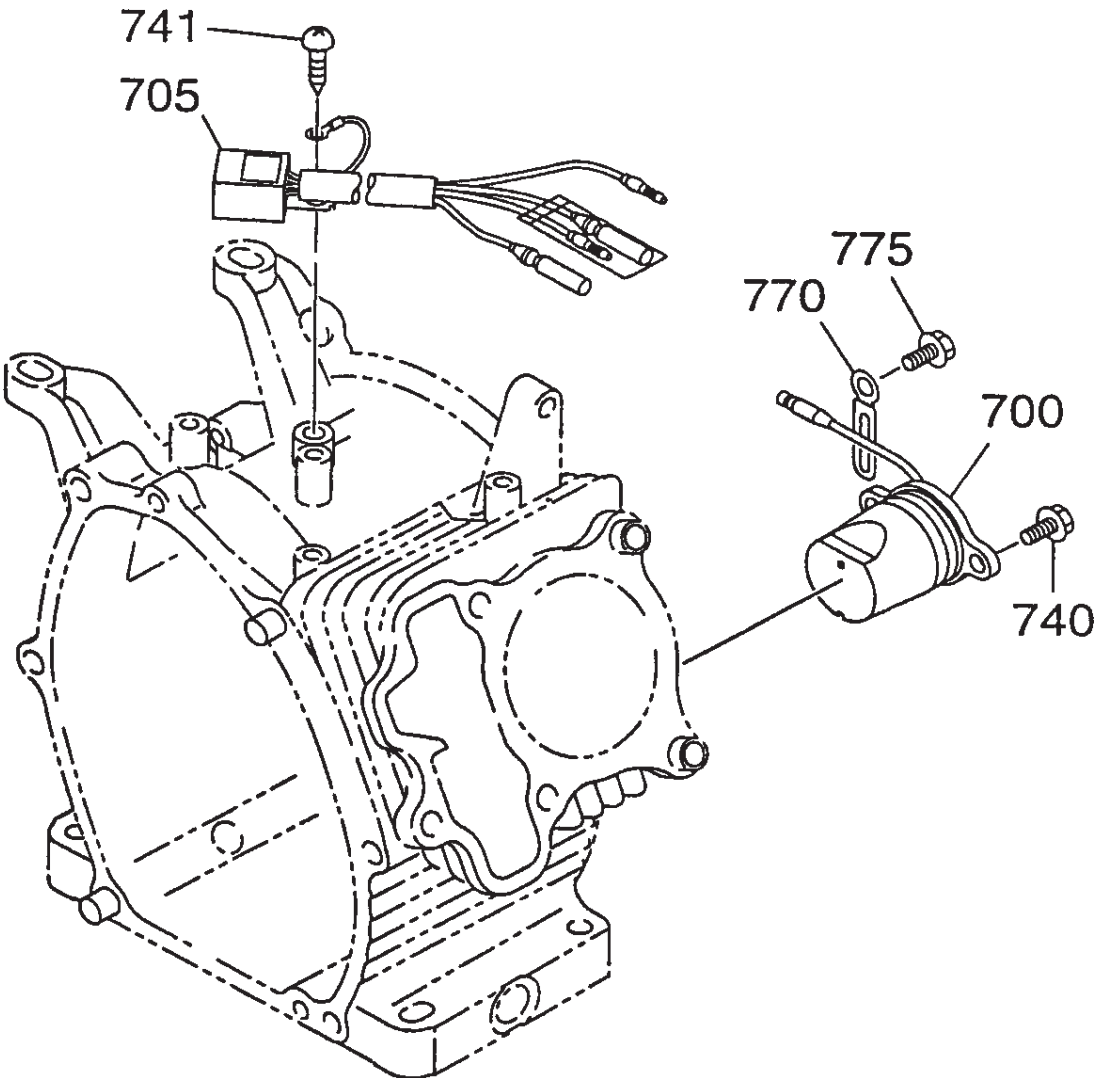

# ROBIN EX170D50021 ENGINE— ELECTRIC DEVICE ASSY.

ELECTRIC DEVICE ASSY.

<u>NO</u>	<u>PART NO</u>	<u>PART NAME</u>	<u>QTY.</u>	<u>REMARKS</u>
700	2777630111	OIL SENSOR CP	1	
705	KU31104311	CONTROL ASSY.	1	
740	0011406160	BOLT & WASHER ASSY.	2	
741	0150040090	TAPPING SCREW	1	
770	2147900601	CLAMP CP	1	
775	0110060020	FLANGE BOLT	1	

# ROBIN EX170D50021 ENGINE— FUEL TANK ASSY.

## FUEL TANK ASSY.

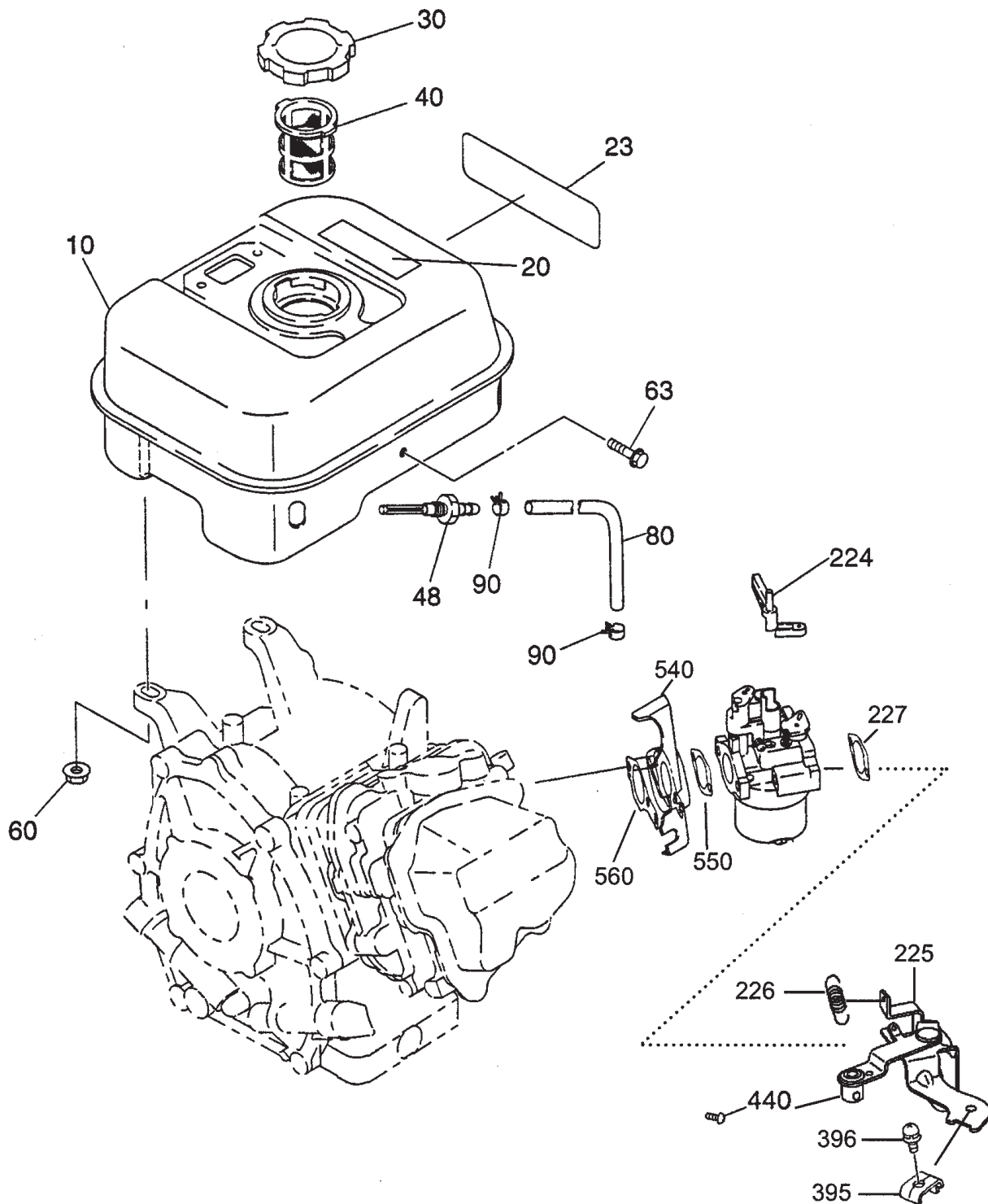

# ROBIN EX170D50021 ENGINE— FUEL TANK ASSY.

## FUEL TANK ASSY.

<u>NO</u>	<u>PART NO</u>	<u>PART NAME</u>	<u>QTY.</u>	<u>REMARKS</u>
10	2776010201	FUEL TANK CP	1	
20	0732005181	LABEL, WARNING	1	
23	2779510103	LABEL, MODEL	1	
30	0430440050	FUEL TANK CAP CP	1	
40	0641360010	FUEL FILTER	1	
48	0505120020	UNION	1	
60	0023806000	FLANGE NUT	2	
63	0110060130	FLANGE BOLT	1	
80	0851060000	RUBBER PIPE	1	
90	X561100030	HOSE CLAMP	2	
224	2774380101	CHOKE LEVER CP	1	
225		REMOTE CHOKE CONTROL	1	
226		SPRING	1	
227	2773260408	GASKET	1	
395	2774390203	CLAMP	1	
396	0131050030	SCREW AND WASHER	1	
440	0043104080	SCREW	1	
540	27732902H3	INSULATOR	1	
550	27735902H3	GASKET 1, INSULATOR	1	
560	27735903H3	GASKET 2, INSULATOR	1	

**PAYMENT TERMS**

Terms of payment for parts are net 10 days.

**FREIGHT POLICY**

All parts orders will be shipped collect or prepaid with the charges added to the invoice. All shipments are F.O.B. point of origin. Multiquip's responsibility ceases when a signed manifest has been obtained from the carrier, and any claim for shortage or damage must be settled between the consignee and the carrier.

**MINIMUM ORDER**

The minimum charge for orders from Multiquip is \$15.00 net. Customers will be asked for instructions regarding handling of orders not meeting this requirement.

**RETURNED GOODS POLICY**

Return shipments will be accepted and credit will be allowed, subject to the following provisions:

1. A Returned Material Authorization must be approved by Multiquip prior to shipment.
2. To obtain a Return Material Authorization, a list must be provided to Multiquip Parts Sales that defines item numbers, quantities, and descriptions of the items to be returned.
  - a. The parts numbers and descriptions must match the current parts price list.
  - b. The list must be typed or computer generated.
  - c. The list must state the reason(s) for the return.
  - d. The list must reference the sales order(s) or invoice(s) under which the items were originally purchased.
  - e. The list must include the name and phone number of the person requesting the RMA.
3. A copy of the Return Material Authorization must accompany the return shipment.
4. Freight is at the sender's expense. All parts must be returned freight prepaid to Multiquip's designated receiving point.

5. Parts must be in new and resalable condition, in the original Multiquip package (if any), and with Multiquip part numbers clearly marked.
6. The following items are not returnable:
  - a. Obsolete parts. (If an item is in the price book and shows as being replaced by another item, it is obsolete.)
  - b. Any parts with a limited shelf life (such as gaskets, seals, "O" rings, and other rubber parts) that were purchased more than six months prior to the return date.
  - c. Any line item with an extended dealer net price of less than \$5.00.
  - d. Special order items.
  - e. Electrical components.
  - f. Paint, chemicals, and lubricants.
  - g. Decals and paper products.
  - h. Items purchased in kits.
7. The sender will be notified of any material received that is not acceptable.
8. Such material will be held for five working days from notification, pending instructions. If a reply is not received within five days, the material will be returned to the sender at his expense.
9. Credit on returned parts will be issued at dealer net price at time of the original purchase, less a 15% restocking charge.
10. In cases where an item is accepted, for which the original purchase document can not be determined, the price will be based on the list price that was effective twelve months prior to the RMA date.
11. Credit issued will be applied to future purchases only.

**PRICING AND REBATES**

Prices are subject to change without prior notice. Price changes are effective on a specific date and all orders received on or after that date will be billed at the revised price. Rebates for price declines and added charges for price increases will not be made for stock on hand at the time of any price change.

Multiquip reserves the right to quote and sell direct to Government agencies, and to Original Equipment Manufacturer accounts who use our products as integral parts of their own products.

**SPECIAL EXPEDITING SERVICE**

A \$35.00 surcharge will be added to the invoice for special handling including bus shipments, insured parcel post or in cases where Multiquip must personally deliver the parts to the carrier.

**LIMITATIONS OF SELLER'S LIABILITY**

Multiquip shall not be liable hereunder for damages in excess of the purchase price of the item with respect to which damages are claimed, and in no event shall Multiquip be liable for loss of profit or good will or for any other special, consequential or incidental damages.

**LIMITATION OF WARRANTIES**

No warranties, express or implied, are made in connection with the sale of parts or trade accessories nor as to any engine not manufactured by Multiquip. Such warranties made in connection with the sale of new, complete units are made exclusively by a statement of warranty packaged with such units, and Multiquip neither assumes nor authorizes any person to assume for it any other obligation or liability whatever in connection with the sale of its products. Apart from such written statement of warranty, there are no warranties, express, implied or statutory, which extend beyond the description of the products on the face hereof.



# OPERATION AND PARTS MANUAL

## **HERE'S HOW TO GET HELP**

PLEASE HAVE THE MODEL AND SERIAL  
NUMBER *ON-HAND* WHEN CALLING

### **MULTIQUIP CORPORATE OFFICE**

18910 Wilmington Ave.

Carson, CA 90746

Email: [mq@multiquip.com](mailto:mq@multiquip.com)

Internet: [www.multiquip.com](http://www.multiquip.com)

800-421-1244

FAX: 310-537-3927

### **PARTS DEPARTMENT**

800-427-1244

310-537-3700

FAX: 800-672-7877

FAX: 310-637-3284

### **MAYCO PARTS**

800-306-2926

310-537-3700

FAX: 800-672-7877

FAX: 310-637-3284

### **SERVICE DEPARTMENT**

800-421-1244

310-537-3700

FAX: 310-537-4259

### **TECHNICAL ASSISTANCE**

800-478-1244

FAX: 310-631-5032

### **WARRANTY DEPARTMENT**

800-421-1244, EXT. 279

310-537-3700, EXT. 279

FAX: 310-537-1173

Your Local Dealer is:



### **MULTIQUIP INC.**

18910 WILMINGTON AVE.

CARSON, CALIFORNIA 90746

800-421-1244 • 310-537-3700

FAX: 310-537-3927

E-mail: [mq@multiquip.com](mailto:mq@multiquip.com)

Internet: [multiquip.com](http://multiquip.com)