

# OPERATION AND PARTS MANUAL



## MODEL QP-4TE TRASH PUMP (ROBIN GASOLINE ENGINE)

Revision #0 (01/25/05)

To find the latest revision of this  
publication, visit our website at:  
[www.multiquip.com](http://www.multiquip.com)



THIS MANUAL MUST ACCOMPANY THE EQUIPMENT AT ALL TIMES.



**WARNING**



**CALIFORNIA — Proposition 65 Warning**

Engine exhaust and some of its constituents are known to the State of California to cause cancer, birth defects and other reproductive harm.



**Multiquip QP-4TE Trash Pump**

Proposition 65 Warning ..... 2  
 Table Of Contents ..... 4  
 Parts Ordering Procedures ..... 5  
 Safety Message Alert Symbols ..... 6-7  
 Rules For Safe Operation ..... 8-9  
 General Information ..... 10  
 Pump Specifications/Dimensions ..... 11  
 Engine Specifications ..... 12  
 Pump Components ..... 13  
 Basic Engine ..... 14  
 Pre-Inspection (Engine) ..... 15  
 Pre-Set-up (Pump) ..... 16  
 Initial Start-up (Engine) ..... 17-18  
 Maintenance (Pump) ..... 19-20  
 Maintenance (Engine) ..... 21-22  
 Preparation for Long-Term Storage ..... 23  
 Troubleshooting (Engine) ..... 24  
 Troubleshooting (Engine/Pump) ..... 25  
 Explanation Of Code In Remarks Column ..... 26  
 Suggested Spare Parts ..... 27  
 Pump Assy. .... 28-31

**ROBIN EX270D50220 Engine (EPA)**

Air Cleaner Assy. .... 32-33  
 Camshaft Assy. .... 34-35  
 Carburetor Assy. .... 36-37  
 Crankcase Assy. .... 38-39  
 Crankshaft/Piston Assy. .... 40-41  
 Cylinder Head Assy. .... 42-43  
 Fuel Tank Assy. .... 44-45  
 Governor Assy. .... 46-47  
 Ignition Coil/Flywheel Assy. .... 48-49  
 Muffler Assy ..... 50-51  
 Oil Sensor Assy ..... 52-53  
 Recoil Starter Assy ..... 54-55  
 Terms and Conditions of Sale ..... 56

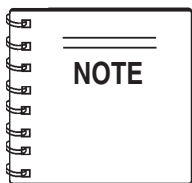

*Specification and part number are subject to change without notice.*

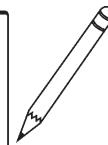
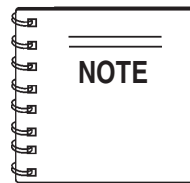

*As a continuing effort to update our parts book, contact the MULTIQIP literature department for the latest revision of your "Operation and Parts Manual"*

www.multiquip.com

**Ordering parts has never been easier!  
Choose from three easy options:**



**Order via Internet (Dealers Only):**

Order parts on-line using Multiquip's SmartEquip website!

- View Parts Diagrams
- Order Parts
- Print Specification Information



If you have an MQ Account, to obtain a Username and Password, E-mail us at: [parts@multiquip.com](mailto:parts@multiquip.com).

To obtain an MQ Account, contact your District Sales Manager for more information.

Goto [www.multiquip.com](http://www.multiquip.com) and click on **Order Parts** to log in and save!

Use the **internet** and qualify for a **5% Discount** on *Standard orders* for all orders which include complete part numbers.\*

Note: Discounts Are Subject To Change



**Order via Fax (Dealers Only):**

All customers are welcome to order parts via Fax.

**Domestic (US) Customers dial:**  
1-800-6-PARTS-7 (800-672-7877)

**Fax** your order in and qualify for a **3% Discount** on *Standard orders* for all orders which include complete part numbers.\*

Note: Discounts Are Subject To Change



**Order via Phone: Domestic (US) Dealers Call:**  
1-800-427-1244

**Non-Dealer Customers:**

Contact your local Multiquip Dealer for parts or call 800-427-1244 for help in locating a dealer near you.



**International Customers** should contact their local Multiquip Representatives for Parts Ordering information.

**When ordering parts, please supply:**

- |  |  |
|--|--|
| <ul style="list-style-type: none"> <li><input type="checkbox"/> Dealer Account Number</li> <li><input type="checkbox"/> Dealer Name and Address</li> <li><input type="checkbox"/> Shipping Address (if different than billing address)</li> <li><input type="checkbox"/> Return Fax Number</li> <li><input type="checkbox"/> Applicable Model Number</li> <li><input type="checkbox"/> Quantity, Part Number and Description of Each Part</li> </ul> | <ul style="list-style-type: none"> <li><input type="checkbox"/> Specify Preferred Method of Shipment:                     <ul style="list-style-type: none"> <li><input checked="" type="checkbox"/> Fed Ex/UPS <input checked="" type="checkbox"/> DHL</li> <li><input type="checkbox"/> Priority One <input checked="" type="checkbox"/> Truck</li> <li><input type="checkbox"/> Ground</li> <li><input type="checkbox"/> Next Day</li> <li><input type="checkbox"/> Second/Third Day</li> </ul> </li> </ul> |
|--|--|

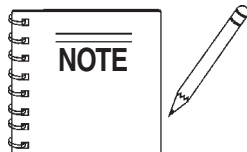

Unless otherwise indicated by customer, all orders are treated as *Standard Orders* and will ship within 24 hours. We will make every effort to ship *Air Shipments* the same day the order is received, if received prior to 2PM PST. *Stock Orders* must be noted on fax or web order form.

**WE ACCEPT ALL MAJOR CREDIT CARDS!**



# QP-4TE — SAFETY MESSAGE ALERT SYMBOLS

## FOR YOUR SAFETY AND THE SAFETY OF OTHERS!

Safety precautions should be followed at all times when operating this equipment. Failure to read and understand the Safety Messages and Operating Instructions could result in injury to yourself and others.

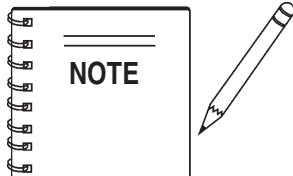

This Operation and Parts Manual has been developed to provide complete instructions for the safe and efficient operation of the **MQ Model QP-4TE Trash Pump**. Refer to the engine manufacturers' instructions for data relative to its safe operation.

**Before using this pump, ensure that the operating individual has read and understands all instructions in this manual.**

## SAFETY MESSAGE ALERT SYMBOLS

The three (3) Safety Messages shown below will inform you about potential hazards that could injure you or others. The Safety Messages specifically address the level of exposure to the operator, and are preceded by one of three words: **DANGER**, **WARNING**, or **CAUTION**.

### **DANGER**

You **WILL** be **KILLED** or **SERIOUSLY** injured if you **DO NOT** follow directions.

### **WARNING**

You **CAN** be **KILLED** or **SERIOUSLY** injured if you **DO NOT** follow directions.

### **CAUTION**

You **CAN** be **INJURED** if you **DO NOT** follow directions.

## HAZARD SYMBOLS

Potential hazards associated with the operation of the **MQ Model QP-4TE** will be referenced with Hazard Symbols which appear throughout this manual, and will be referenced in conjunction with Safety Message Alert Symbols.

### **WARNING - Lethal Exhaust Gas Hazards**

Engine exhaust gases contain poisonous carbon monoxide. This gas is colorless and odorless, and can cause death if inhaled. **NEVER** operate this equipment in a confined area or enclosed structure that does not provide ample free flow air.



### **DANGER - Explosive Fuel Hazards**

**Gasoline** is extremely flammable, and its vapors can cause an explosion if ignited. **DO NOT** start the engine near spilled fuel or combustible fluids.

**DO NOT** fill the fuel tank while the engine is running or hot. **DO NOT** overfill tank, since spilled fuel could ignite if it comes into contact with hot engine parts or sparks from the ignition system. Store fuel in approved containers, in well-ventilated areas and away from sparks and flames.



### **WARNING - Burn Hazards**

Engine components can generate extreme heat. To prevent burns, **DO NOT** touch these areas while the engine is running or immediately after operations. Never operate the engine with heat shields or heat guards removed.



### **WARNING - Respiratory Hazards**

**ALWAYS** wear approved **respiratory** protection when required.



# QP-4TE — SAFETY MESSAGE ALERT SYMBOLS

## CAUTION - Rotating Parts Hazards

**NEVER** operate equipment with covers, or guards removed. Keep fingers, hands, hair and clothing away from all moving parts to prevent injury.



## CAUTION - Equipment Damage Hazards

Other important messages are provided throughout this manual to help prevent damage to your pump, other property, or the surrounding environment.

## CAUTION - Accidental Starting Hazards

**ALWAYS** place the engine **ON/OFF** switch in the **OFF** position when the pump is not in use.



## CAUTION - Eye and Hearing Hazards

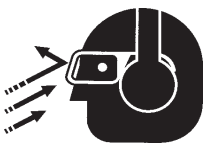

**ALWAYS** wear approved eye and hearing protection.

## CAUTION - Read Manual

Before attempting to operate the pump, and to avoid serious injury to personnel, always read and understand operation manual. Failure to read and understand operation manual could result in serious harm or even death!

	<b>WARNING</b> To avoid injury, you <b>MUST</b> read and understand operator's manual before using this machine.
	This machine to be operated by qualified personnel only. Ask for training as needed.

## DANGER - Refueling Hazard

**NEVER** refuel pump when placed in a truck-bed with plastic liner. The possibility exists of explosion due to static electricity. When adding fuel, remove pump from truck bed and place on ground.

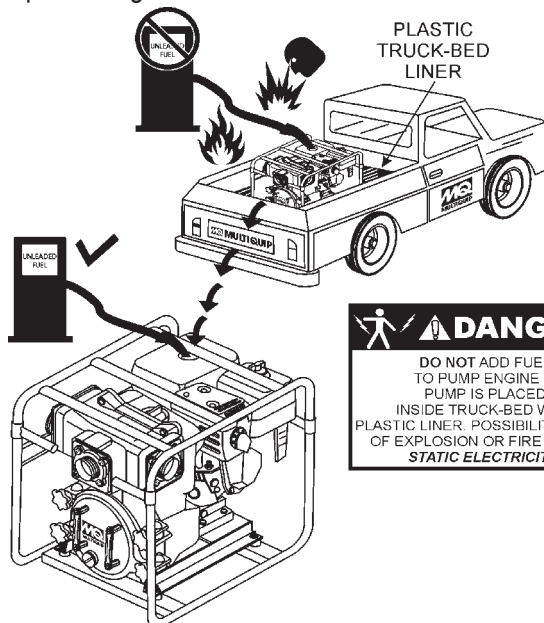

	<b>DANGER</b> DO NOT ADD FUEL TO PUMP ENGINE IF PUMP IS PLACED INSIDE TRUCK-BED WITH PLASTIC LINER. POSSIBILITY EXISTS OF EXPLOSION OR FIRE DUE TO <i>STATIC ELECTRICITY</i> .
--	---

# QP-4TE — RULES FOR SAFE OPERATION

## DANGER

Read this manual!

Failure to follow instructions in this manual may lead to serious injury or even death! This equipment is to be operated by trained and qualified personnel only! This equipment is for industrial use only.

The following safety guidelines should always be used when operating the **MQ Model QP-4TE Trash Pump**.

### GENERAL SAFETY

- **DO NOT** operate or service this equipment before reading this entire manual. 
- This equipment should not be operated by persons under 18 years of age.
- **NEVER** operate this equipment without proper protective clothing, shatterproof glasses, steel-toed boots and other protective devices required by the job.



- **NEVER** operate this equipment when not feeling well due to fatigue, illness or taking medicine. 
- **NEVER** operate this equipment under the influence of **drugs** or **alcohol**.

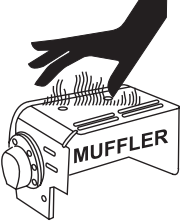
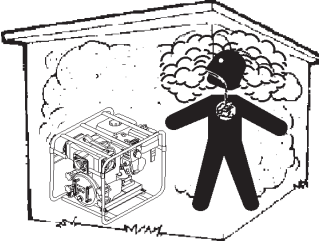

- **ALWAYS** wear proper respiratory (mask), hearing and eye protection equipment when operating the pump. 
- Whenever necessary, replace nameplate, operation and safety decals when they become difficult read.
- Manufacture does not assume responsibility for any accident due to equipment modifications.
- **NEVER** use accessories or attachments, which are not recommended by Multiquip for this equipment. Damage to the equipment and/or injury to user may result.

- **NEVER** touch the hot exhaust manifold, muffler or cylinder. Allow these parts to cool before servicing engine or mixer. 
- **High Temperatures** – Allow the engine to cool before adding fuel or performing service and maintenance functions. Contact with **hot!** components can cause serious burns.
- The engine section of this pump requires an adequate free flow of cooling air. **NEVER** operate the pump in any enclosed or narrow area where free flow of the air is restricted. If the air flow is restricted it will cause serious damage to the mixer or engine and may cause injury to people. Remember the pump's engine gives off **DEADLY** carbon monoxide gas. 

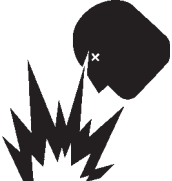
- **ALWAYS** refuel in a well-ventilated area, away from sparks and open flames.
- **ALWAYS** use extreme caution when working with **flammable** liquids. When refueling, **stop the** engine and allow it to cool. **DO NOT smoke** around or near the machine. Fire or explosion could result from fuel vapors, or if fuel is spilled on a hot engine. 
- **NEVER** operate the pump in an explosive atmosphere or near combustible materials. An explosion or fire could result causing severe **bodily harm or even death**. 
- Topping-off to filler port is dangerous, as it tends to spill fuel.
- Maintain this equipment in a safe operating condition at all times.
- **ALWAYS** store equipment properly when it is not being used. Equipment should be stored in a clean, dry location out of the reach of children.

## QP-4TE — RULES FOR SAFE OPERATION

- **ALWAYS** be sure the operator is familiar with proper safety precautions and operation techniques before using pump.
- **NEVER** leave the pump unattended, turn off engine when unattended.
- **NEVER** pump volatile, explosive, flammable or low flash point fluids. These fluids could ignite or explode.
- **NEVER** operate the pump in an **explosive** atmosphere.
- Keep all **inexperienced** and **unauthorized** people away from the equipment at all times.
- Before starting the pump, check that the clean-out cover is securely fasten.
- **ALWAYS** ensure pump is on level ground before use.
- Become familiar with the components of the pump before operating.
- **ALWAYS** replace any worn or damaged warning decals.
- **NEVER** pump corrosive chemicals or water containing toxic substances. These fluids could create serious health and environmental hazards. Contact local authorities for assistance.
- **NEVER** open the priming plug when pump is hot. Hot water inside could be pressurized much like the radiator of an automobile. Allow pump to cool to the touch before loosening plug.
- **NEVER** open the pump housing during operation or start the pump with the clean-out cover removed. The rotating impeller inside the pump can cut or sever objects caught in it.
- **NEVER** block or restrict flow from discharge hose. Remove kinks from discharge line before starting pump. Operation with a blocked discharge line can cause water inside pump to overheat.
- **ALWAYS** fill the pump casing with water before starting the engine. Failure to maintain water inside the pump housing will cause severe damage to the pump.
- In **winter** drain water from pump housing to prevent freezing.
- **ALWAYS** test the engine **ON/OFF** switch before operating. The purpose of this switch is to shut down the engine .
- Refer to the appropriate engine manual for technical questions or information recommended by Multiquip for this equipment. Damage to the equipment and/or injury to user may result.

### TRANSPORTING

- **ALWAYS** shutdown engine before transporting.
- Tighten fuel tank cap securely and close fuel cock to prevent fuel from spilling.
- Drain fuel when transporting pump over long distances or bad roads.

### MAINTENANCE

- **NEVER** lubricate components or attempt service on a running pump.
- **ALWAYS** allow the pump a proper amount of time to cool before servicing.
- Keep the pump in proper running condition.
- Fix damage to the pump immediately and always replace broken parts.
- Dispose of hazardous waste properly. Examples of potentially hazardous waste are used motor oil, fuel and fuel filters.
- **DO NOT** use food or plastic containers to dispose of hazardous waste.

### EMERGENCIES

- **ALWAYS** know the location of the nearest **fire extinguisher** and **first aid kit**.



- In emergencies **always** know the location of the nearest phone or **keep a phone on the job site**. Also know the phone numbers of the nearest **ambulance**, **doctor** and **fire department**. This information will be invaluable in the case of an emergency.



## APPLICATION

The **QP-4TE Trash Pump** is designed to be used for de-watering applications. Both the suction and discharge ports on the QP-4TE pump use a 4-inch diameter opening, which allows the pump to pump at a rate of approximately 528 gallons/minute (gpm) or 2,000 liters/minute (lpm).

Trash pumps derive their name from their ability to handle a greater amount of debris and solids than standard centrifugal pumps. These pumps generally handle solids up to 1/2 the size of the discharge opening making them less likely to clog. Also trash pumps are capable of handling water with 25% solids by weight.

The advantage of using a trash pump is that it can be quickly and easily disassembled in the field "**without tools**" and easily cleaned when clogged.

## Power Plant

This trash pump is powered by a 9 horsepower, air-cooled, 4-stroke, single-cylinder, **ROBIN EX-270D50021** gasoline engine that incorporates a low "**Oil Alert Feature**".

## Oil Alert Feature

In the event of **low oil** or **no oil**, the engine has a built-in oil alarm engine shut-down feature. In the event the oil level is low the engine will automatically shut-down.

## Suction Lift

This pump is intended to be used for dewatering applications and is capable of suction lifts up to 25 feet at sea level. For optimal suction lift performance keep the suction hose or line as short as possible. In general always put the pump as close to the water as possible.

## Pump Support

The pump should always be placed on **solid stationary ground** in a level position.

**NEVER** place the pump on **soft soil**. The suction hose or pipe connection should always be checked for tightness and leaks. A small suction leak in the hose or fittings could prevent the pump from priming.

## Elevation

Elevations over 3,000 feet will effect the performance of the pump. Due to less atmospheric pressure at higher altitudes, pumps **DO NOT** have the priming ability that they have at sea level.

A general rule of thumb is that for every 1,000 feet of elevation above sea level a pump will lose one foot of priming ability.

For example, in Flagstaff, Arizona where the elevation is approximately 7,000 feet, the pump would have a suction lift of only 18 feet rather than the 25 feet at sea level.

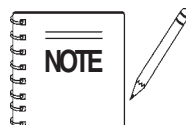

Please contact your nearest authorized MQ dealer for any accessories that your pump may require.

# QP-4TE — SPECIFICATIONS/DIMENSIONS (PUMP)

**Table 1. Specifications (Pump)**

Pump	Model	QP-4TE
	Type	Trash Pump
	Suction & Discharge Size	4x4 in. (100 x 100 mm.)
	Maximum Pumping Capacity	528 gallons/minute (2000 liters/minute)
	Max. Solids Diameter	2.00 in. (50.0 mm.)
	Max. Lift	25 ft. (7.62 meters)
	Max. Head	85 ft. (26.0 meters)
	Max. Horsepower	9 HP/3600RPM
Dimension (L x W x H)	30.1 x 27.4 X 30.7 in. (765 X 695 X 780 cm.)	
Dry Net Weight	194 lbs. (88 Kg.)	

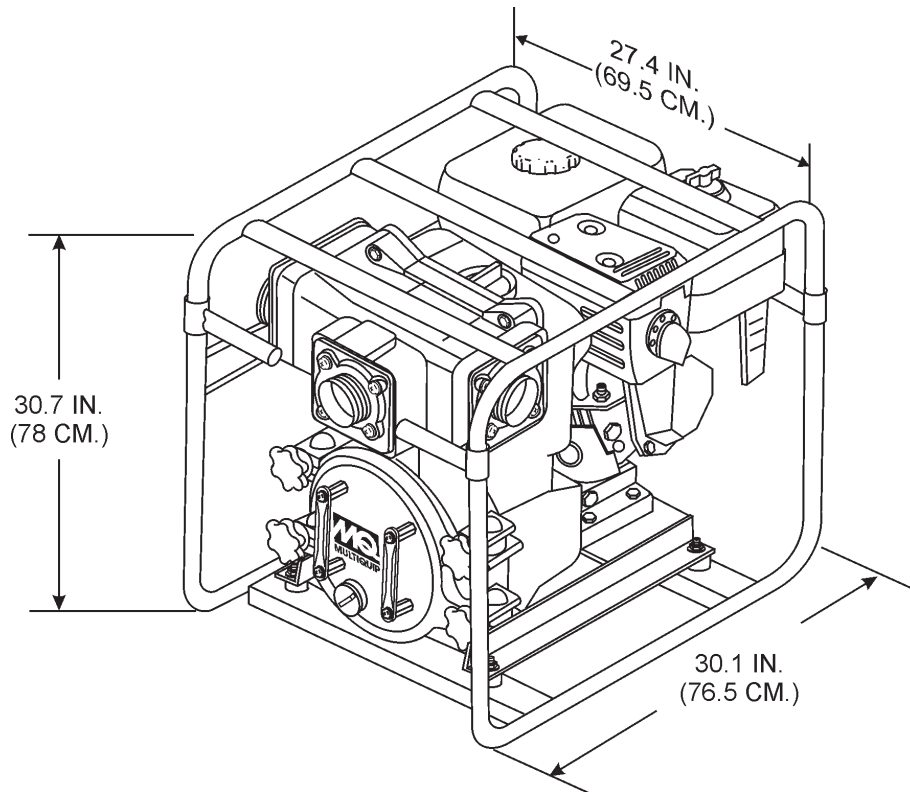

**Figure 1. QP-4TE Pump Dimensions**

**Table 2. Specifications (Engine)**

Engine	Model	ROBIN EX-270D50220
	Type	Air-cooled 4 stroke, Single Cylinder, OHV, Horizontal Shaft Gasoline Engine
	Displacement	265 cc
	Continuous Output	5.1 H.P./3600 R.P.M.
	Max Output	9.0 H.P./4000 R.P.M.
	Fuel Tank Capacity	1.72 gallons (6.5 liters)
	Fuel	Unleaded Automobile Gasoline
	Lube Oil Capacity	1.16 quarts (1.1 liters)
	Oil Alert System	Yes
	Speed Control Method	Centrifugal Fly-weight Type
	Starting Method	Recoil Start
Dimension (L x W x H)	13.97 x 16.5 X 16.14 in. (355 X 420 X 410 mm.)	
Dry Net Weight	46.3 lbs (21 Kg.)	

## QP-4TE — PUMP COMPONENTS

Figure 2 shows a typical application using the QP-4TE Centrifugal Trash pump. Please note that this pump is intended for the removal of clean water and water containing some debris and solids. Maximum size of solids should not exceed 2 inches (50 mm) in diameter. **DO NOT** set strainer on bottom of water bed. Placing the strainer above the water bed will prevent the pump from drawing in excessive amounts of sand and foreign debris.

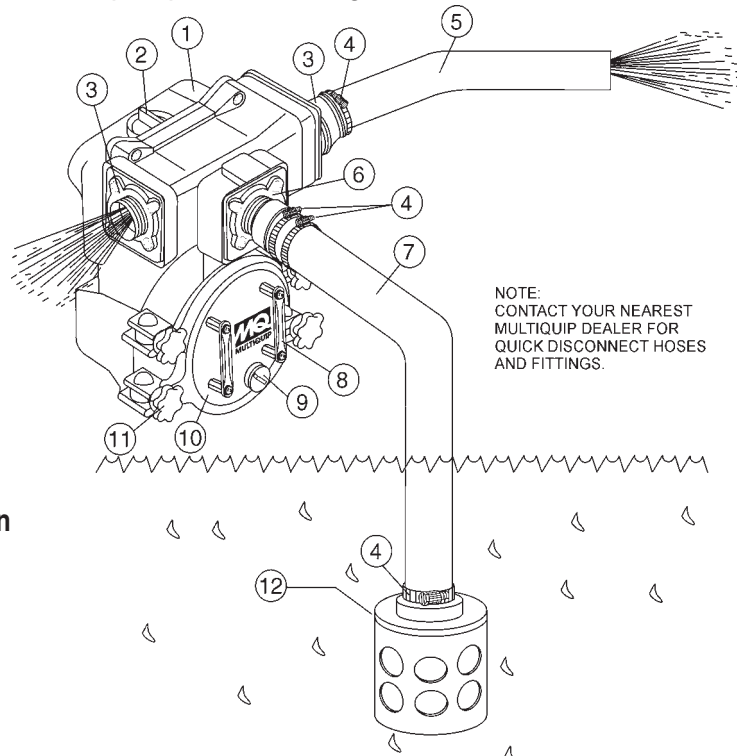

Figure 2. QP-4TE Pump Application

- 1. Pump** – The MQ Model QP-4TE is a 4-inch trash pump used in general de-watering applications. Typical dewatering applications consist of manholes, septic tanks, fast and slow seepage ditch water, silt water, mud water and muck water.
- 2. Fill Cap** – Prior to operation, the pump casing should be filled with water. Remove this cap to add water to the pump. After the initial prime, a sufficient amount of water will be retained in the casing so that the operator will not need to re-prime later.  
If the casing is dry or has insufficient water, the pump will have difficulty in priming which could lead to premature mechanical seal wear thus causing damage to the pump.
- 3. Discharge Port** – Connect a 4-inch discharge hose to this port.
- 4. Worm Clamp** – Used to secure the hose to the inlet and outlet ports on the pump. Use two clamps to secure the hose on the inlet side of the pump.
- 5. Discharge Hose** – Connect this flexible rubber hose to the discharge port on the pump. Make sure that the hose lays flat and is not kinked. Use only recommended type discharge hose. Contact Multiquip Parts Department for ordering information.
- 6. Suction Port** – Connect a 4-inch inlet hose to this port. Use two worm clamps to secure the hose.
- 7. Suction Hose** – Connect this flexible rubber hose to the suction port on the pump. Make sure that the hose lays flat and is not kinked. Use only recommended type suction hose. Contact Multiquip parts department for ordering information
- 8. Clean-out Cover Handles** – To gain access to the pump's clean-out area, grip both handles, then pull to remove cover. Make sure both locking knobs have been released before attempting to remove clean-out cover.
- 9. Drain Plug** – Remove this plug to drain water from the pump.
- 10. Clean-out Cover** – Remove cover to gain access to the clean-out area.
- 11. Locking Knobs** – Turn both knobs clockwise to secure clean-out cover, turn counter-clockwise to release cover.
- 12. Strainer** – Always attach a strainer to bottom side of the suction hose to prevent large objects and debris from entering the pump. Strainer should be positioned so that it will remain completely under water. Running the pump with the strainer above water for long periods can damage pump.

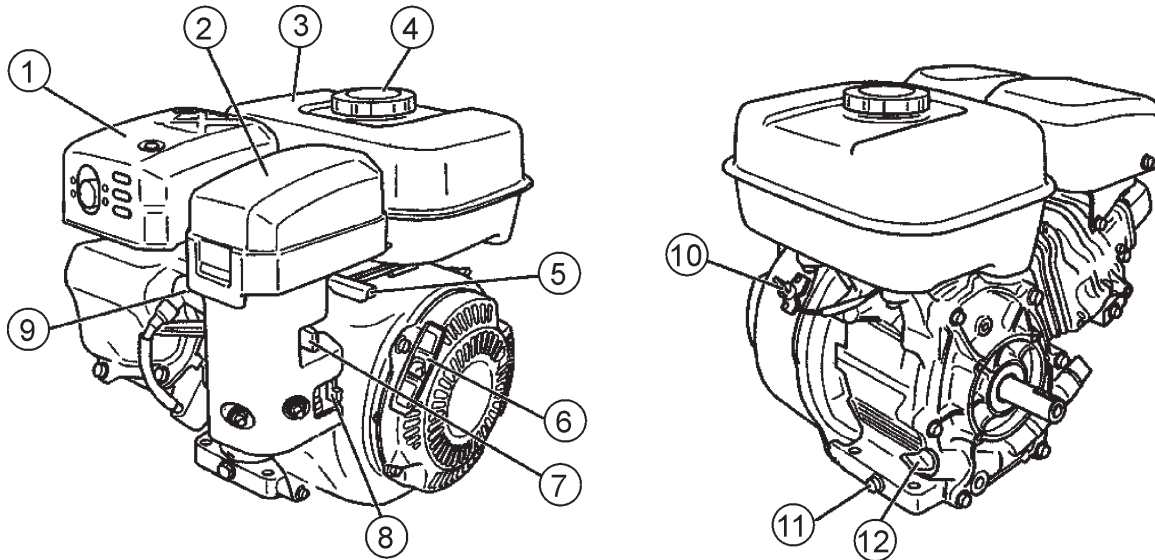



Figure 3. Engine Controls and Components

## INITIAL SERVICING

The engine (Figure 3) must be checked for proper lubrication and filled with fuel prior to operation. Refer to the **ROBIN** engine service manual for instructions and details for proper operation and servicing.

1. **Muffler** – Used to reduce noise and emissions.

**! WARNING**



Engine components can generate extreme heat. To prevent burns, **DO NOT** touch these areas while the engine is running or immediately after operating. **NEVER** operate the engine with the muffler removed.

2. **Air Cleaner** – Prevents dirt and other debris from entering the fuel system. Remove wing-nut on top of air filter canister to gain access to filter element.
3. **Fuel Tank** – Holds unleaded gasoline. For additional information refer to ROBIN engine owner's manual.
4. **Fuel Filler Cap** – Remove this cap to add unleaded gasoline to the fuel tank. Make sure cap is tightened securely. **DO NOT** over fill.

**! DANGER**



Adding fuel to the tank should be done only when the engine is stopped and has had an opportunity to cool down. In the event of a fuel spill, **DO NOT** attempt to start the engine until the fuel residue has been completely wiped up, and the area surrounding the engine is dry.

5. **Throttle Lever** – Used to adjust engine RPM speed (lever advanced forward **SLOW**, lever back toward operator **FAST**).
6. **Recoil Starter (pull rope)** – Manual-starting method. Pull the starter grip until resistance is felt, then pull briskly and smoothly.
7. **Choke Lever** – Used in the starting of a cold engine, or in cold weather conditions. The choke enriches the fuel mixture.
8. **Fuel Valve Lever** – **OPEN** to let fuel flow, **CLOSE** to stop the flow of fuel.
9. **Spark Plug** – Provides spark to the ignition system. Set spark plug gap to 0.6 - 0.7 mm (0.028 - 0.031 inch) Clean spark plug once a week.
10. **Engine ON/OFF Switch** – ON position permits engine starting, OFF position stops engine operations.
11. **Oil Drain Plug** – Remove this plug to drain engine oil from the crankcase.
12. **Oil Dipstick/ Filler Cap**– Remove the filler cap dipstick when checking the engine oil level. Add engine oil through this filler port. See Table 5 for recommended type engine oil.

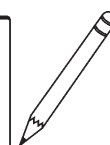
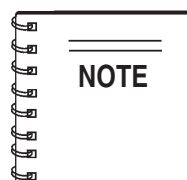

Operating the engine without an air filter, with a damaged air filter, or a filter in need of replacement will allow dirt to enter the engine, causing rapid engine wear.

## CAUTION - Read Manual

Please read the entire maintenance section in this manual before servicing the pump. In addition for operator safety, please read all safety messages at the beginning of the manual

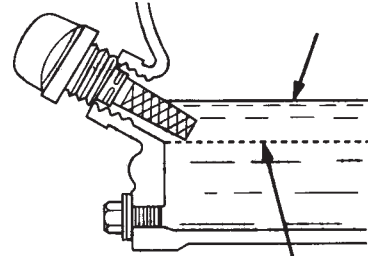

Figure 5. Engine Oil Dipstick (Oil Level)

## Inspection

1. Clean the pump, removing dirt and dust, particularly the engine cooling air inlet, carburetor and air cleaner.
2. Check the air filter for dirt and dust. If air filter is dirty, replace air filter with a new one as required.
3. Check carburetor for external dirt and dust. Clean with dry compressed air.
4. Check fastening nuts and bolts for tightness.

## Engine Oil Check

1. To check the engine oil level, place the pump on secure level ground with the engine stopped.
2. Remove the filler dipstick from the engine oil filler hole (Figure 4) and wipe clean.

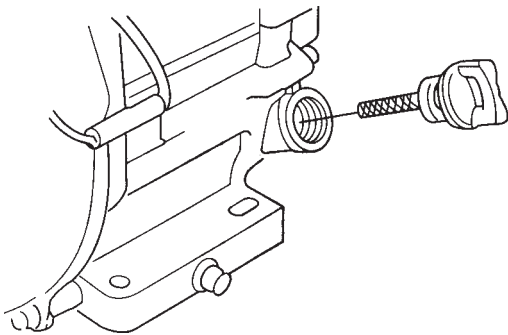

Figure 4. Engine Oil Dipstick (Removal)

3. Insert and remove the dipstick without screwing it into the filler neck. Check the oil level shown on the dipstick.
4. If the oil level is low (Figure 5), fill to the edge of the oil filler hole with the recommended oil type (Table 3). Maximum oil capacity is .63 quarts (.60 liters)

Table 3. Oil Type

Season	Temperature	Oil Type
Summer	25°C or Higher	SAE 10W-30
Spring/Fall	25°C~10°C	SAE 10W-30/20
Winter	0°C or Lower	SAE 10W-10

## DANGER - Explosive Fuel

Motor fuels are highly flammable and can be dangerous if mishandled. **DO NOT** smoke while refueling. Adding fuel to the tank should be done only when the engine is stopped and has had an opportunity to cool down. **DO NOT** attempt to refuel the pump if the engine is **hot!** or **running!** In the event of any spilled fuel, wipe up immediately. **DO NOT** attempt to start the engine until the fuel residue has been completely wiped up, and the area surrounding the engine is dry.

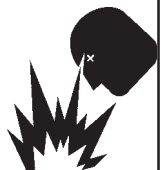

## Fuel Check

1. Remove the gasoline cap located on top of fuel tank.
2. Visually inspect to see if the fuel level is low. If fuel is low, replenish with unleaded fuel.
3. When refueling, be sure to use a strainer for filtration. **DO NOT** top-off fuel. Wipe up any spilled fuel **immediately!**

## Before Starting:

### CAUTION - General Safety Precautions

**NEVER** operate the pump in a confined area or enclosed area structure that does not provide ample **free flow of air**.



**ALWAYS** wear approved eye and hearing protection before operating the compactor.

## Before Starting

1. Read safety instructions at the beginning of manual.
2. Place pump as near to water as possible, on a firm flat, level surface.
3. To prime pump, remove fill cap (Figure 2) and fill pump casing with water. If the pump casing is not filled with water before starting, it will not begin pumping.



### CAUTION - Pump Casing

Pump casing **must** be filled with water before using pump. Otherwise pump will not be able to begin pumping.

### WARNING - Fill Cap

**DO NOT** open **fill cap** if pump is **hot!** Water inside may be under pressure.

4. Check for **leaks** between pump and engine. If water is leaking between the pump and engine housing, the seal inside the pump may be worn or damaged. Continued operation of the pump is not recommended. Further usage of the pump under these conditions may cause severe water damage to engine.

## Hoses and Clamps

1. Check that all hoses are **securely** attached to the pump. Make certain suction hose (Figure 2) does not have any air leakage. Tighten hose clamps and couplings as required.
2. It is recommended that 2 clamps be used when securing the suction hose to the inlet side (suction) of the pump.

3. Remember suction hoses must be **rigid** enough not to collapse when the pump is in operation.
4. Check that the **discharge** hose (Figure 2) is not restricted. Place hose so that it lays as straight as it is possible on the ground. Remove any twists or sharp bends from hose which may block the flow of water.

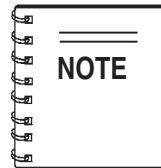

Suction and discharge hoses are available from Multiquip. Contact your nearest dealer for more information.

5. The discharge hose is usually a **collapsible** (thin-walled) hose, however if a thin-walled discharge hose is not available, a rigid suction hose can be substituted in its place.
6. Make sure the **suction strainer** (Figure 2) is clean and securely attached to the water end of the suction hose. The strainer is designed to protect the pump by preventing large objects from being pulled into the pump.

### CAUTION - Strainer

The strainer should be positioned so it will remain completely **under water**. Running the pump with the strainer above water for long periods can damage the pump.

### CAUTION - Flammable Fluids

**DO NOT** pump flammable fluids, corrosive chemicals or fluids containing toxic substances. These fluids can create potentially dangerous health and environmental hazards. Contact local authorities for assistance.

### CAUTION - Mechanical Seal

This pump uses a water-cooled **mechanical seal** to prevent water from seeping into the engine. The passage of water through the pump casing lubricates the seal and prevents it from overheating. **NEVER!** operate the pump without water in the casing as this will cause damage to the mechanical seal.

## QP-4TE — INITIAL START-UP (ENGINE)

### CAUTION

**DO NOT** attempt to operate the pump until the Safety, General Information and Inspection sections of this manual have been *read and thoroughly understood*.



This section is intended to assist the operator with the *initial start-up* of the trash pump. It is extremely important that this section be read carefully before attempting to use the pump in the field.

### Starting the Engine

1. Place the engine *fuel valve lever* (Figure 6) to the "ON" position.

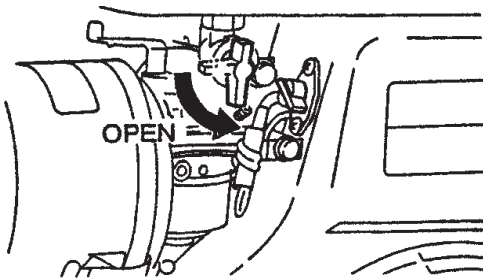

Figure 6. Engine Fuel Valve Lever (ON Position)

2. Move the *throttle lever* (Figure 7) away from the slow position, about 1/3 of the way toward the fast position.

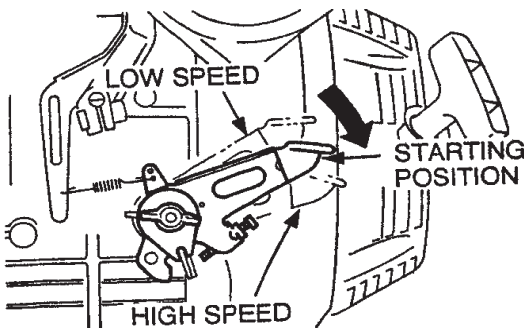

Figure 7. Throttle Lever (1/3 Start Position)

3. Place the *choke lever* (Figure 8) in the "OPEN" position if starting a *cold* engine.

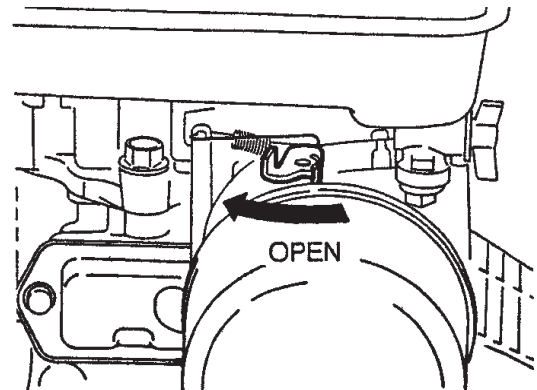
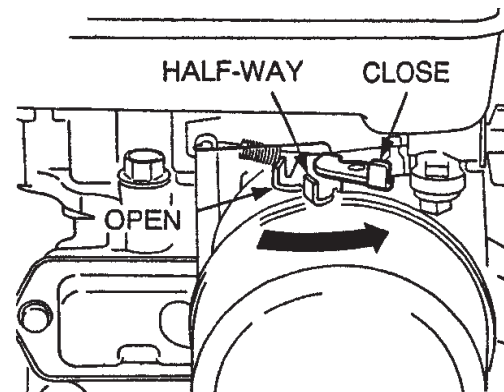

Figure 8. Engine Choke Lever (Open)

4. Place the *choke lever* (Figure 9) in the "CLOSED" position if starting a *warm engine* or the *temperature is warm*.



Close the choke lever.

Figure 9. Engine Choke Lever (Closed)

5. Place the *engine ON/OFF switch* (Figure 10) in the "ON" position.

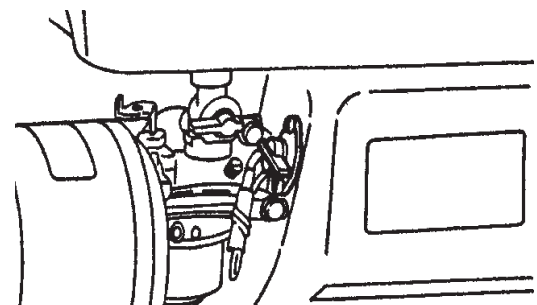

Figure 10. Engine ON/OFF Switch (ON Position)

## QP-4TE — INITIAL START-UP (ENGINE)

- Grasp the starter grip (Figure 11) and slowly pull it out. The resistance becomes the hardest at a certain position, corresponding to the compression point. Pull the starter grip briskly and smoothly for starting.

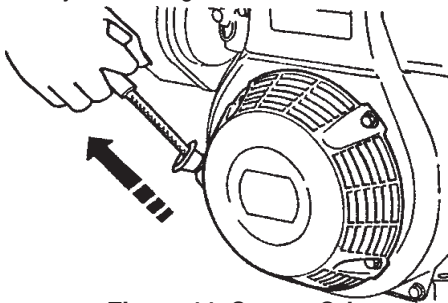
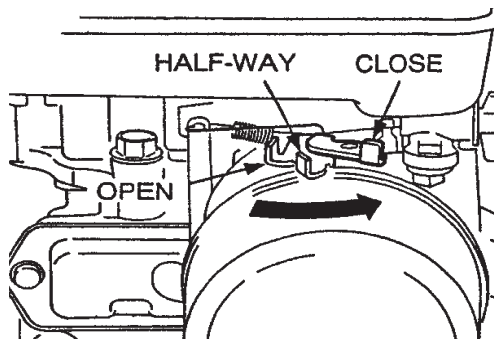

Figure 11. Starter Grip

- If the engine has started, slowly return the choke lever (Figure 12) to the **CLOSED** position. If the engine has not started repeat steps 1 through 6.



Close the choke lever.

Figure 12. Choke Lever (Closed)

- Before the pump is placed into operation, run the engine for several minutes. Check for fuel leaks, and noises that would associate with a loose component.
- To begin pumping, place the throttle lever (Figure 13) in the "RUN" position.

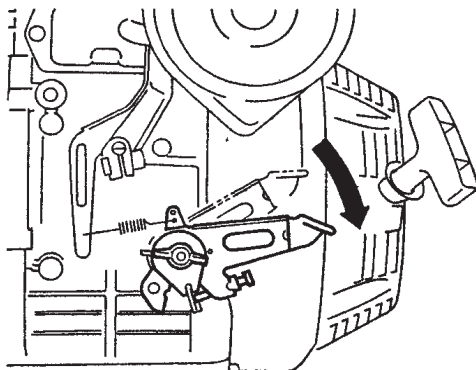

Figure 13. Throttle Lever (Run)

### CAUTION

**ALWAYS** run engine at *full speed* while pumping.

### Stopping The Engine

#### Normal Shutdown

- Move the throttle lever to the **IDLE** position (Figure 14) and run the engine for three minutes at low speed.

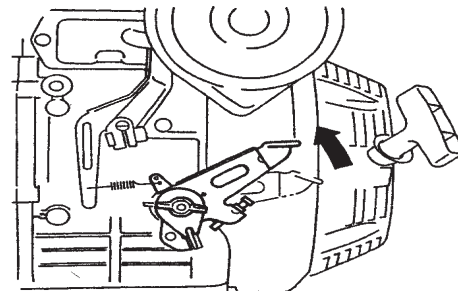

Figure 14. Throttle Lever (Idle)

- After the engine *cools*, turn the engine ON/OFF switch to the "OFF" position (Figure 15).

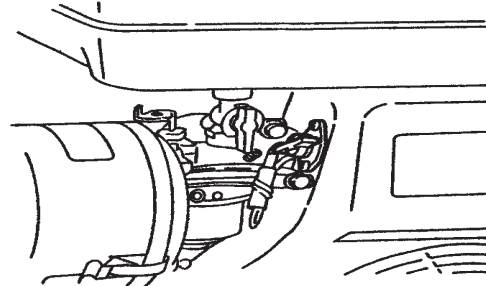

Figure 15. Engine ON/OFF Switch (OFF)

- Place the **fuel shut-off lever** (Figure 16) in the **OFF** position.

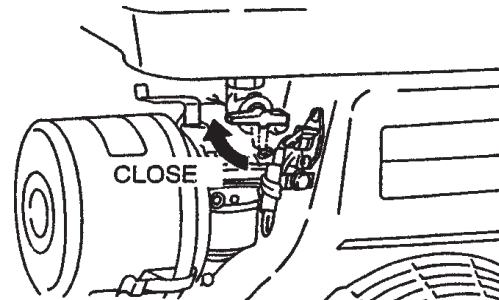

Figure 16. Fuel Valve Lever (OFF)

#### Emergency Showdown

- Move the throttle lever quickly to the **IDLE** position, and place the engine ON/OFF switch in the **OFF** position.

## Pump Vacuum Test

### CAUTION - Priming Pump

**DO NOT** attempt to start the engine unless the pump has previously been **primed** with water. Severe pump damage will occur if pump has not been primed.

To perform the pump vacuum test do the following:

1. Remove the pump fill cap (Figure 2), and fill the pump with water.
2. Start the engine as outlined in the initial start-up section, and wait for the pump to begin pumping.
3. As shown in Figure 17 (next page), place a water hose inside the discharge opening of the pump, and turn on the water. This flow of water into the discharge opening will **prevent** the pump from running dry.
4. Place the **Pump Vacuum Tester** (P/N 7000030) over the pump suction (inlet) opening (Figure 19) with the vacuum gauge facing upwards. It may be necessary to apply a small amount of water around the rubber seal of the vacuum tester to make a good suction fit.
5. Check and make sure that there are no air leaks between the vacuum tester and the inlet port on the pump. If air leaks are present reseal vacuum tester.
6. Run the pump for a few minutes while monitoring the vacuum gauge. If the gauge indicates a reading between -25 and -20 in. Hg. (inches of mercury) then it can be assumed that the pump is working correctly.

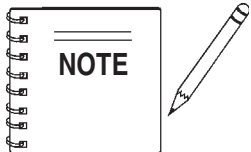

25 in. Hg (inches of mercury) translates into 25 feet of lift at **sea level**.

7. If the vacuum tester gauge indicates a reading **below** -20 in. Hg, it can then be assumed that the pump is not functioning correctly, and corrective action needs to be taken.
6. To test the **flapper valve**, shut down the engine. The vacuum tester should remain attached to the pump suction inlet port by vacuum. This indicates the pump's flapper valve is seating properly to hold water in the suction hose when the engine is stopped. This prevents backflow and allows for faster priming when the engine is restarted.

## Pump Cleaning

After pumping water containing large amounts of dirt and debris, perform the following:

1. Remove the drain plug from the pump housing (Figure 2) and drain any water left in the pump.
2. Clean and remove dirt, debris from pump casing. Inspect impeller and volute for wear. Replace any damaged or worn parts.

## CAUTION

DO NOT RUN PUMP WITHOUT WATER.

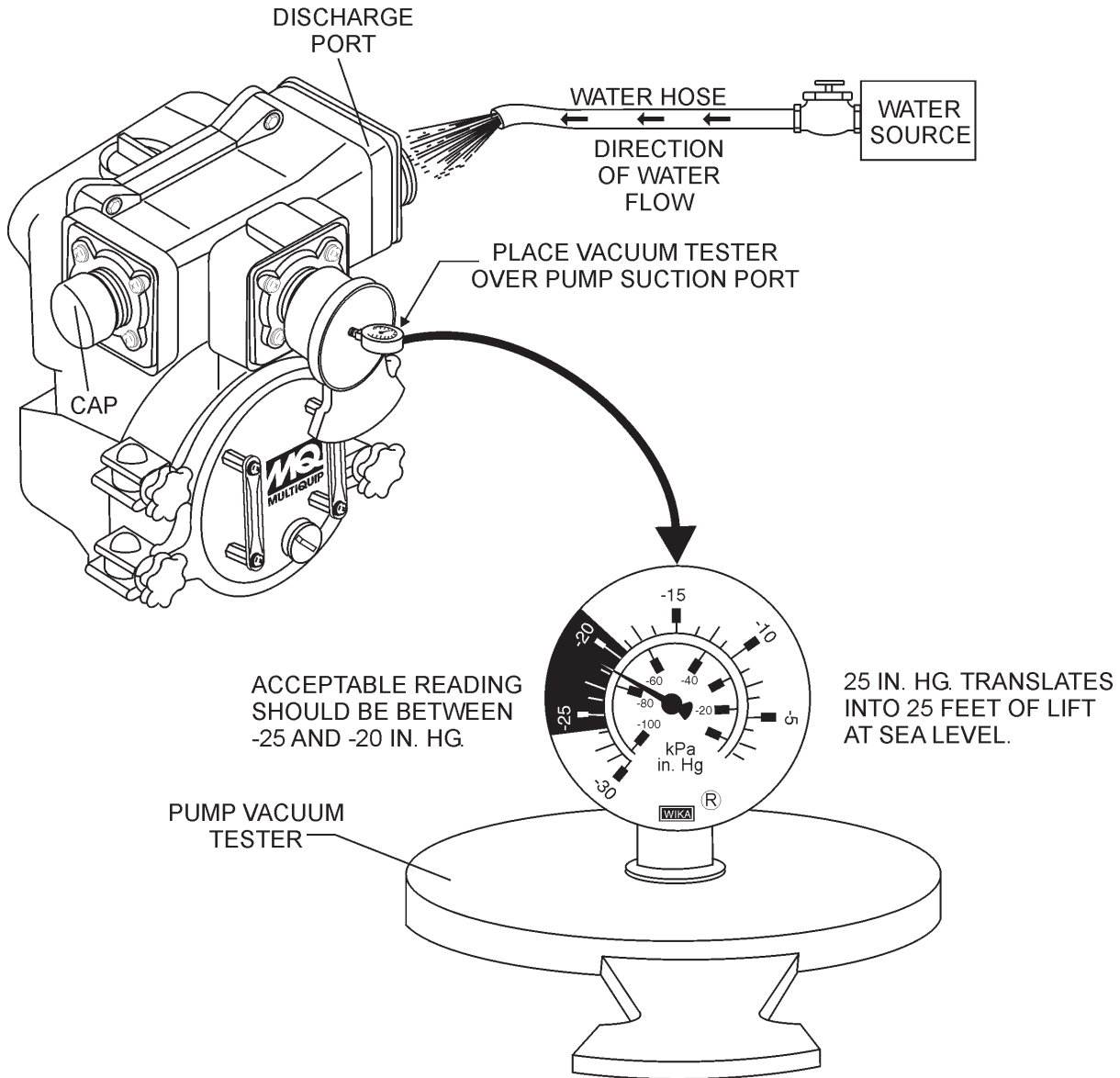
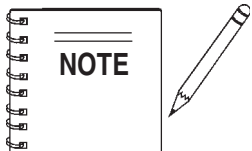
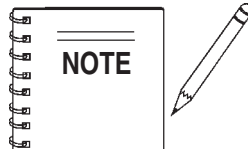

Figure 17. Pump Vacuum Tester



Pressure reading may vary depending on altitude.



When performing pressure test, be sure to place cap over one of the discharge ports.

## Engine Maintenance

Perform engine maintenance procedures as referenced by Table 4 below:

Table 4. Engine Maintenance Schedule							
DESCRIPTION (3)	OPERATION	BEFORE	FIRST MONTH OR 10 HRS.	EVERY 3 MONTHS OR 25 HRS.	EVERY 6 MONTHS OR 50 HRS.	EVERY YEAR OR 100 HRS.	EVERY 2 YEARS OR 200 HRS.
Engine Oil	CHECK	X					
	CHANGE		X				
Air Cleaner	CHECK	X					
	CHANGE			X (1)			
All Nuts & Bolts	Re-tighten If Necessary	X					
Spark Plug	CHECK-CLEAN				X		
	REPLACE						X
Cooling Fins	CHECK				X		
Spark Arrester	CLEAN					X	
Fuel Tank	CLEAN					X	
Fuel Filter	CHECK					X	
Idle Speed	CHECK-ADJUST					X (2)	
Valve Clearance	CHECK-ADJUST						X (2)
Fuel lines	CHECK	Every 2 years (replace if necessary) (2)					

(1) Service more frequently when used in **DUSTY** areas.

(2) These items should be serviced by your servic dealer, unless you have the proper tools and are mechanically proficient. Refer to the ROBIN shop Manual for service procedures

(3) For commercial use, log hours of operation to determine proper maintenance intervals.

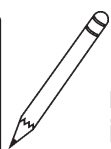
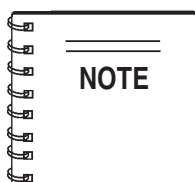

Reference manufacturer engine manual for specific servicing instructions.

## Maintenance

Perform the engine maintenance procedures as indicated below:

### DAILY

- Thoroughly remove dirt and oil from the engine and control area. Clean or replace the air cleaner elements as necessary. Check and retighten all fasteners as necessary. Check the spring box and bellows for oil leaks. Repair or replace as needed.

### WEEKLY

- Remove the fuel filter cap and clean the inside of the fuel tank.
- Remove or clean the filter at the bottom of the tank.
- Remove and clean the spark plug (Figure 18), then adjust the spark gap to 0.028 ~0.031 inch (0.6~0.7 mm). This unit has electronic ignition, which requires no adjustments.

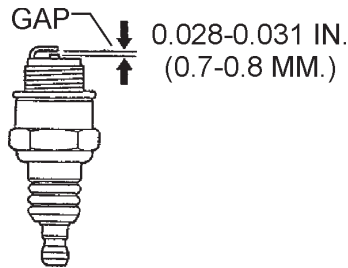

Figure 18. Spark Plug Gap

### ENGINE OIL

- Drain the engine oil when the oil is **warm** as shown in Figure 19.
- Remove the oil drain bolt and sealing washer and allow the oil to drain into a suitable container.
- Replace engine oil with recommended type oil as listed in Table 3. Engine oil capacity is 1.16 quarts (1.1 liters). **DO NOT** overfill.
- Install drain bolt with sealing washer and tighten securely.

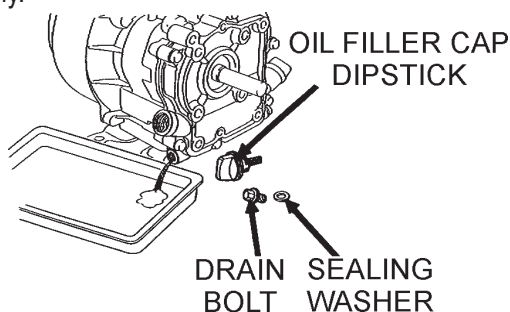

Figure 19. Engine Oil (Draining)

## **!** DANGER - Pump Cleaning (Gasoline)

**DO NOT** use gasoline as a cleaning solvent, because that would create a risk of fire or explosion.



### ENGINE AIR CLEANER

- Remove the air cleaner cover and foam filter element as shown in Figure 20.
- Tap the paper filter element (Figure 20) several times on a hard surface to remove dirt, or blow compressed air [not exceeding 30 psi (207 kPa, 2.1 kgf/cm<sup>2</sup>)] through the filter element from the air cleaner case side. **NEVER** brush off dirt. Brushing will force dirt into the fibers. Replace the paper filter element if it is excessively dirty.
- Clean foam element in warm, soapy water or nonflammable solvent. Rinse and dry thoroughly. Dip the element in clean engine oil and completely squeeze out the excess oil from the element before installing.

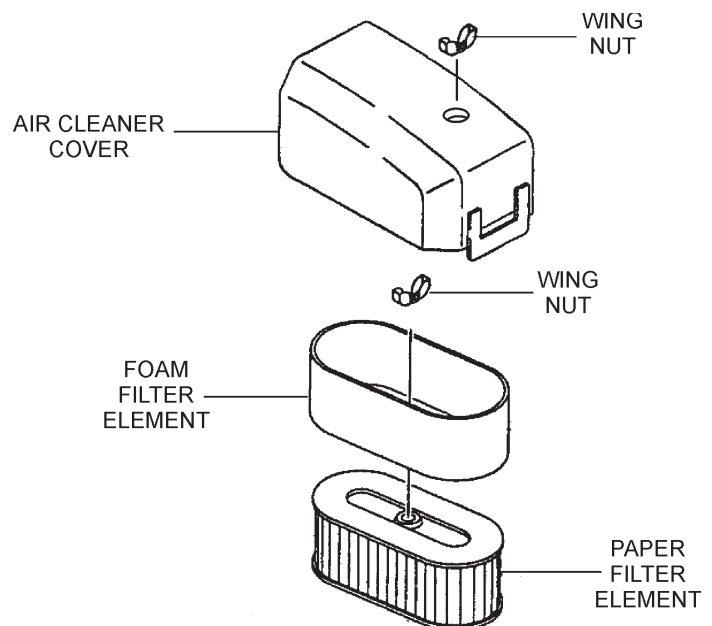

Figure 20. Engine Air Cleaner

### Pump Storage

For storage of the pump for over 30 days, the following is required:

- Drain the fuel tank completely.
- Run the engine until the fuel in the injection system is completely consumed.
- Completely drain used oil from the engine crankcase and fill with fresh clean oil, then follow the procedures described in the engine manual for engine storage.
- Remove the drain plug from the pump and drain out any water from left in the housing.
- Remove the pump cover and clean inside of pump housing. Coat inside of pump housing with a light film of oil to reduce corrosion. A spray can of oil works well for this application.
- Cover suction and discharge ports with duct tape to prevent any foreign matter from falling into pump.
- Cover pump and engine with plastic covering or equivalent and store in a clean, dry place.
- To protect the water cooled-seals, place one-half pint of lubricating oil (new or used) through the discharge opening on the pump and crank the engine several times. This will prevent excessive corrosion and also keep the mechanical seal lubricated.

# QP-4TE — TROUBLESHOOTING (ENGINE)

**TABLE 5. ENGINE TROUBLESHOOTING**

SYMPTOM	POSSIBLE PROBLEM	SOLUTION
<b>Difficult to start</b>		
Fuel is available but spark plug will not ignite. (Power available at high tension cable).	Ignition plug being bridge?	Check ignition system.
	Carbon deposit at ignition?	Clean or replace ignition.
	Short circuit due to defective insulators?	Replace insulators.
	Improper spark gap?	Set spark plug gap to the correct gap.
Fuel is available but spark plug will not ignite. (Power <b>NOT</b> available at high tension cable).	Short circuit at stop switch?	Check stop switch circuit. Replace stop switch if defective.
	Ignition coil defective?	Replace ignition coil.
Fuel is available and spark plug ignites (compression <b>normal</b> ).	Muffler clogged with carbon deposits?	Clean or replace muffler.
	Mixed fuel quality is inadequate?	Check fuel to oil mixture.
	Fuel in use inadequate (water, dust)?	Flush fuel sytem and replace with fresh fuel.
	Air Cleaner clogged?	Clean or replace air cleaner.
Fuel is available and spark plug ignites (compression <b>low</b> ).	Defective cylinder head gasket?	Tighten cylinder head bolts or replace head gasket.
	Cylinder worn?	Replace cylinder.
	Spark plug loose?	Tighen spark plug.
<b>Operation not satisfactory</b>		
Not enough power available (compression normal, no miss-firing).	Air cleaner clogged?	
	Air in fuel line?	Bleed (remove air) from fuel line.
	Fuel level in carbureator float chamber improper?	Adjust carbureator float
	Carbon deposits in cylinder?	Clean or replace cylinder
Not enough power available (compression normal, miss-firing).	Ignition coil defective?	Flush fuel sytem and replace with fresh fuel.
	Ignition plug often shorts?	Replace ignition wires, clean ignition.
	Fuel in use inadequate (water, dust)?	Flush fuel sytem and replace with fresh fuel.
Engine overheats.	Excessive carbon depostion in combustion chamber?	Clean or replace crankcase.
	Exhaust or muffler clogged with carbon.	Clean or replace muffler.
	Spark plug heat value incorrect?	Replace spark plug with correct type spark plug.

# QP-4TE — TROUBLESHOOTING (ENGINE/PUMP)

## TABLE 5. ENGINE TROUBLESHOOTING (Continued)

SYMPTOM	POSSIBLE PROBLEM	SOLUTION
<b>Operation not satisfactory</b>		
Rotational speed fluctuates.	Governor adjustment improper?	Adjust governor to correct lever.
	Governor spring defective?	Clean or replace ignition.
	Fuel flow erratic?	Check fuel line.
	Air taken in through suction line?	Check suction line.
Recoil starter not working properly.	Dust in rotating part?	Clean recoil starter assembly.
	Spring spring failure?	Replace sprial spring.

## TABLE 6 PUMP TROUBLESHOOTING

SYMPTOM	POSSIBLE PROBLEM	SOLUTION
Pump does not take on water.	Not enough priming water in the housing?	Add water.
	Engine speed too low?	Increase throttle.
	Strainer plugged?	Clean strainer.
	Suction hose damaged?	Replace or repair hose, and clamps
	Air leak at suction port?	Check that fittings are tight and properly sealed.
	Pump is located too high above water line?	Move pump closer to water.
	Debris collecting in pump housing?	Clean pump housing.
	Too much distance between impeller and volute.	Adjust clearance by adding shims or replace impeller. Min. .006" - Max. .020"
	Water leaking out weep hole between pump and engine?	Check condition of mechanical seal and gaskets, between pump end and engine housing.
Pump takes in water, little or no discharge.	Engine speed too low?	Increase throttle speed.
	Suction strainer partially plugged?	Clean strainer.
	Impeller/Volute worn?	Adjust clearance by adding shims or replace impeller/volute
Suction hose leaks at inlet.	Fittings/clamps are not sealed properly?	Tighten, replace or add clamp. (Keep extra seals on pump)
	Hose diameter is too large?	Use smaller diameter hose or replace hose.
Discharge does not stay on coupling.	Pressure too high?	Check pressure, add additional clamp.
	Hose kinked or end blocked?	Check hose.
Impeller does not turn: pump is hard to start.	Impeller jammed or blocked?	Open pump cover and clean dirt and debris from inside housing.
	Impeller and volute binding?	Adjust clearance by removing shim from behind impeller.
	Defective engine?	See Hatz Diesel Engine Owner's Manual.

# QP-4TE — EXPLANATION OF CODE IN REMARKS COLUMN

The following section explains the different symbols and remarks used in the Parts section of this manual. Use the help numbers found on the back page of the manual if there are any questions.

The contents and part numbers listed in the parts section are subject to change **without notice**. Multiquip does not guarantee the availability of the parts listed.

Sample Parts List:

NO.	PART NO.	PART NAME	QTY.	REMARKS
1	12345	BOLT .....	1 ....	INCLUDES ITEMS W/*
2*		WASHER, 1/4 IN. ....		NOT SOLD SEPARATELY
2*	12347	WASHER, 3/8 IN. ....	1 ....	MQ-45T ONLY
3	12348	HOSE .....	A/R ..	MAKE LOCALLY
4	12349	BEARING .....	1 ....	S/N 2345B AND ABOVE

## NO. Column

**Unique Symbols** - All items with same unique symbol (\*, #, +, %, or >) in the number column belong to the same assembly or kit, which is indicated by a note in the “Remarks” column.

**Duplicate Item Numbers** - Duplicate numbers indicate multiple part numbers are in effect for the same general item, such as different size saw blade guards in use or a part that has been updated on newer versions of the same machine.

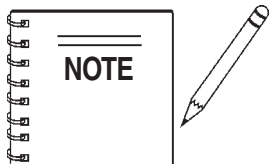

When ordering a part that has more than one item number listed, check the remarks column for help in determining the proper part to order.

## PART NO. Column

**Numbers Used** - Part numbers can be indicated by a number, a blank entry, or TBD.

TBD (To Be Determined) is generally used to show a part that has not been assigned a formal part number at time of publication.

A blank entry generally indicates that the item is not sold separately or is not sold by Multiquip. Other entries will be clarified in the “Remarks” Column.

## QTY. Column

**Numbers Used** - Item quantity can be indicated by a number, a blank entry, or A/R.

A/R (As Required) is generally used for hoses or other parts that are sold in bulk and cut to length.

A blank entry generally indicates that the item is not sold separately. Other entries will be clarified in the “Remarks” Column.

## REMARKS Column

Some of the most common notes found in the “Remarks” Column are listed below. Other additional notes needed to describe the item can also be shown.

**Assembly/Kit** - All items on the parts list with the same unique symbol will be included when this item is purchased.

Indicated by:

“INCLUDES ITEMS W/(unique symbol)”

**Serial Number Break** - Used to list an effective serial number range where a particular part is used.

Indicated by:

“S/N XXXXX AND BELOW”

“S/N XXXX AND ABOVE”

“S/N XXXX TO S/N XXX”

**Specific Model Number Use** - Indicates that the part is used only with the specific model number or model number variant listed. It can also be used to show a part is NOT used on a specific model or model number variant.

Indicated by:

“XXXXX ONLY”

“NOT USED ON XXXX”

**“Make/Obtain Locally”** - Indicates that the part can be purchased at any hardware shop or made out of available items. Examples include battery cables, shims, and certain washers and nuts.

**“Not Sold Separately”** - Indicates that an item cannot be purchased as a separate item and is either part of an assembly/kit that can be purchased, or is not available for sale through Multiquip.

## QP-4TE 1 TO 5 UNITS WITH ROBIN EX270D50021 ENGINE

Qty.....	P/N .....	Description
1 .....	0811885433 .....	MECHANICAL SEAL SLEEVE
1 .....	1470040030 .....	IMPELLER
1 .....	1401350350 .....	CHECK VALVE
4 .....	0631211159 .....	DRAIN CAP
4 .....	14660002200002 ....	DRAIN COVER KNOB
1 .....	0742214100 .....	STEEL STRAINER
5 .....	2793260707 .....	ELEMENT AIR CLEANER
5 .....	0650140150 .....	SPARK PLUG (ROBIN)
1 .....	0430440050 .....	CAP, FUEL TANK (ROBIN)
2 .....	0641360010 .....	FUEL, FILTER
1 .....	2795011008 .....	STARTER ROPE

# QP-4TE — PUMP ASSY.

PUMP ASSY.

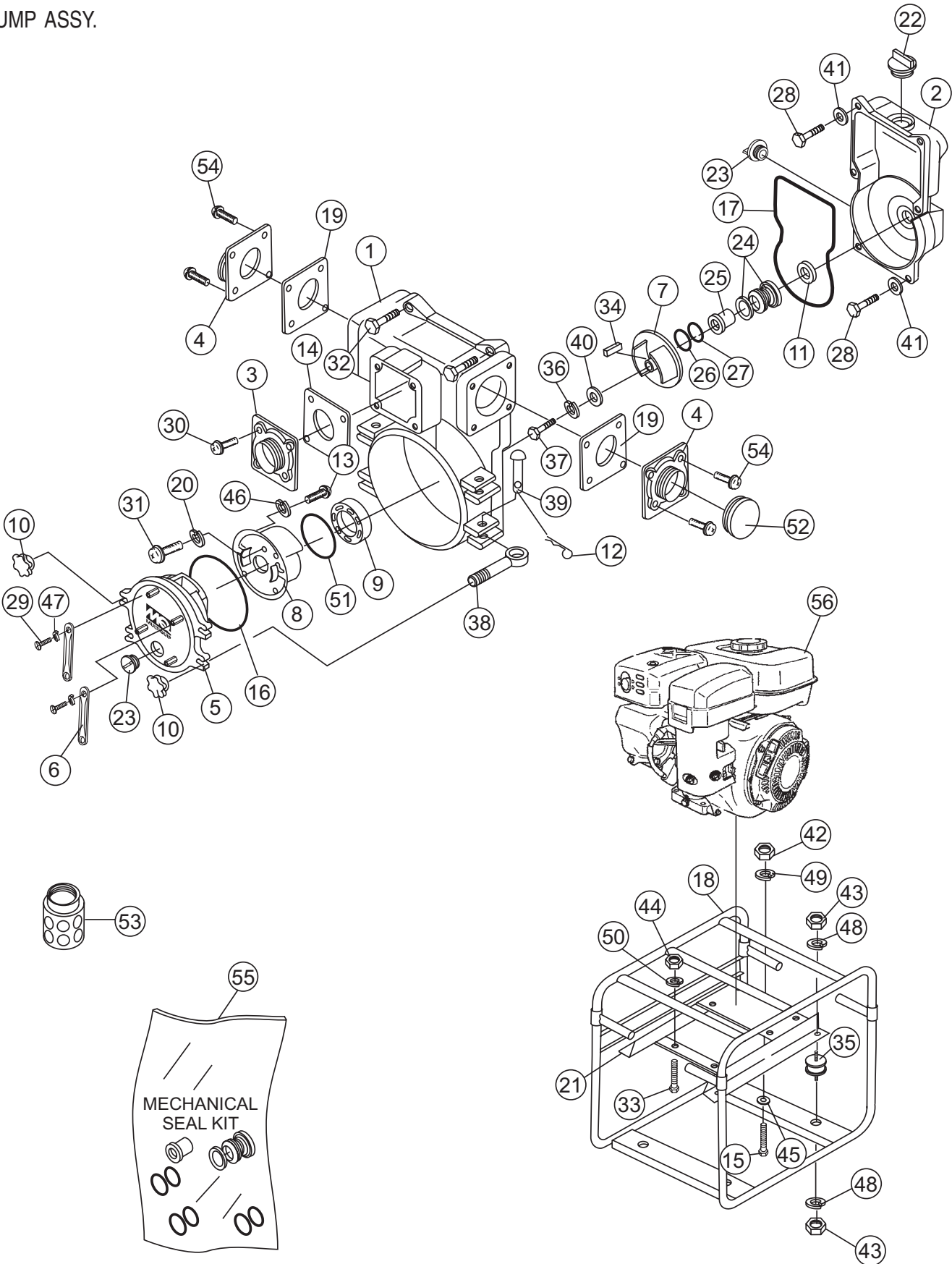

PUMP ASSY.

<u>NO.</u>	<u>PART NO.</u>	<u>PART NAME</u>	<u>QTY.</u>	<u>REMARKS</u>
1	14660600100002	CASING	1	
2	14660600200002	CASING COVER	1	
3	14660000900002	SUCTION COVER, NPT 4"	1	
4	14660000900002	DELIVERY COVER, NPT 4"	2	
5	14660601700002	DRAIN COVER	1	
6	12470002500002	DRAIN COVER SET HANDLE	2	
7	1470040030	IMPELLER	1	
8	1466000130	VOLUTE CASING	1	
9	1466040700	WEAR PLATE	1	
10	14660002200002	DRAIN COVER KNOB	4	
11*	0482200240	O-RING (MECHANICAL SEAL SLEEVE)	1	
12	0641400430	COTTER PIN	4	
13	0131190820	CAP SCREW, M8X20 (VOLUTE CASING)	3	
14	1401350350	CHECK VALVE	1	
15	0105051045	BOLT, M10X45 (ENGINE),	4	
16*	0483602750	O-RING (DRAIN COVER)	1	
17	1466330460	O-RING (CASING)	1	
18	1466214010P002	BASE	1	
19	1401330360	DELIVERY COVER PACKING	2	
20	0451290080	WASHER, LOCK M8 ( WEAR PLATE )	3	
21	14702140200014	ENGINE BASE	1	
22	0631211159	FLOODING CAP, PF1 1/2"	1	
23	0631211159	DRAIN CAP, PF1 1/2"	2	
24*	0803442930	MECHANICAL SEAL	1	
25*	0811885433	MECHANICAL SEAL SLEEVE	1	
26*	0852834525	ADJUST LINER, F45XF25.4 T0.3	1	
27*	0852854525	ADJUST LINER, F45XF25.4 T0.5	1	
28	0131290665	CAP SCREW, 3/8-16UNCx65 (CASING CVR SET BOLT)	4	
29	0141050825	SCREW, M8x25 (DRAIN CUVER SET HANDLE)	4	
30	0131151225	CAP SCREW, M12x25 (SUCTION COVER	4	
31	0131190820	CAP SCREW, M8x20 (WEAR PLATE)	3	
32	0131151230	CAP SCREW, M12x30 (CASING)	6	
33	0105051040	BOLT, M10x40 (PUMP)	2	
34	0520040451	KEY, 6.3x51	1	
35	0723302546	CUSHION RUBBER	4	
36	0451290120	WASHER, LOCK M12 (IMPELLER)	1	
37	0191190745	BOLT, 7/16-20UNFX45 (IMPELLER)	1	
38	1466200270	HINGE BOLT, M10x65	4	
39	1466220280	HINGE PIN	4	

# QP-4TE — PUMP ASSY.

PUMP ASSY.

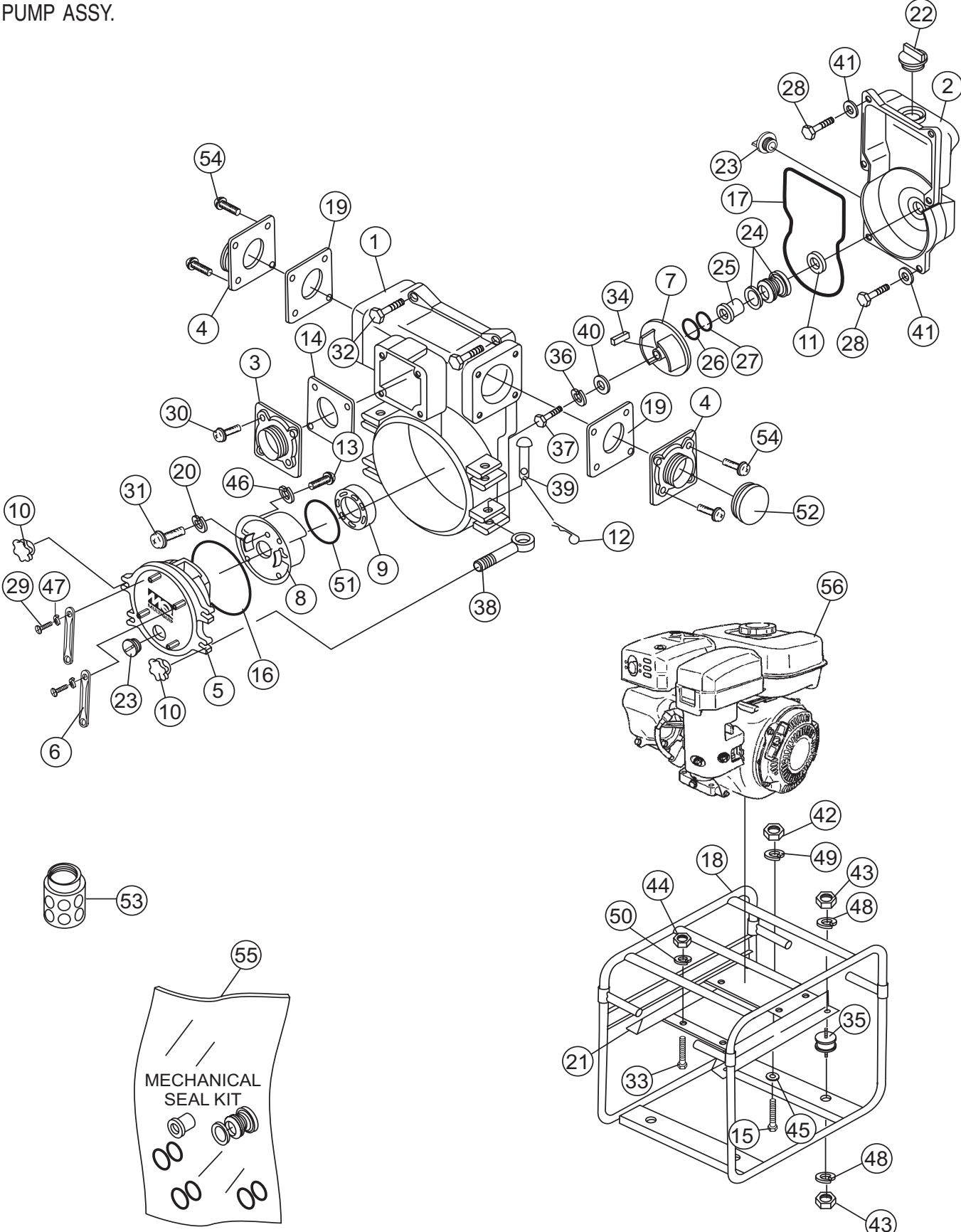

PUMP ASSY.

<u>NO.</u>	<u>PART NO.</u>	<u>PART NAME</u>	<u>QTY.</u>	<u>REMARKS</u>
40	4334201240	IMPELLER WASHER, F42XF12 T4.5	1	
41	0458220070	SEAL WASHER, 3/8" (CASING COVER )	4	
42	0205450100	NUT, M10 (ENGINE)	4	
43	0205450100	NUT, M10 (CUSHION RUBBER)	8	
44	0205450100	NUT, M10 (PUMP)	2	
45	0401450100	WASHER, M10 (ENGINE)	4	
46	0451290080	WASHER, LOCK M8 (VOLUTE CASING)	3	
47	0451250080	WASHER, LOCK M8 (DRAIN COVER SET HANDLE)	4	
48	0451250100	WASHER, LOCK M10 (CUSHION RUBBER)	8	
49	0451250100	WASHER, LOCK M10 (ENGINE)	4	
50	0451250100	WASHER, LOCK M10 (PUMP)	2	
51*	0481572500	O-RING (VOLUTE CASING)	1	
52	1466068050	CAP	1	
53	0742214100	STRAINER	1	
54	0131151220	CAP SCREW, M12x20 (DELIVERY COVER)	8	
55	KIT4TH	KIT, MECHANICAL SEAL, SLEEVE, O-RINGS .....	1	INCLUDES ITEMS W/*
56	EX270D50021	ENGINE, ROBIN	1	

# ROBIN EX270D50220 ENGINE — AIR CLEANER ASSY.

AIR CLEANER ASSY.

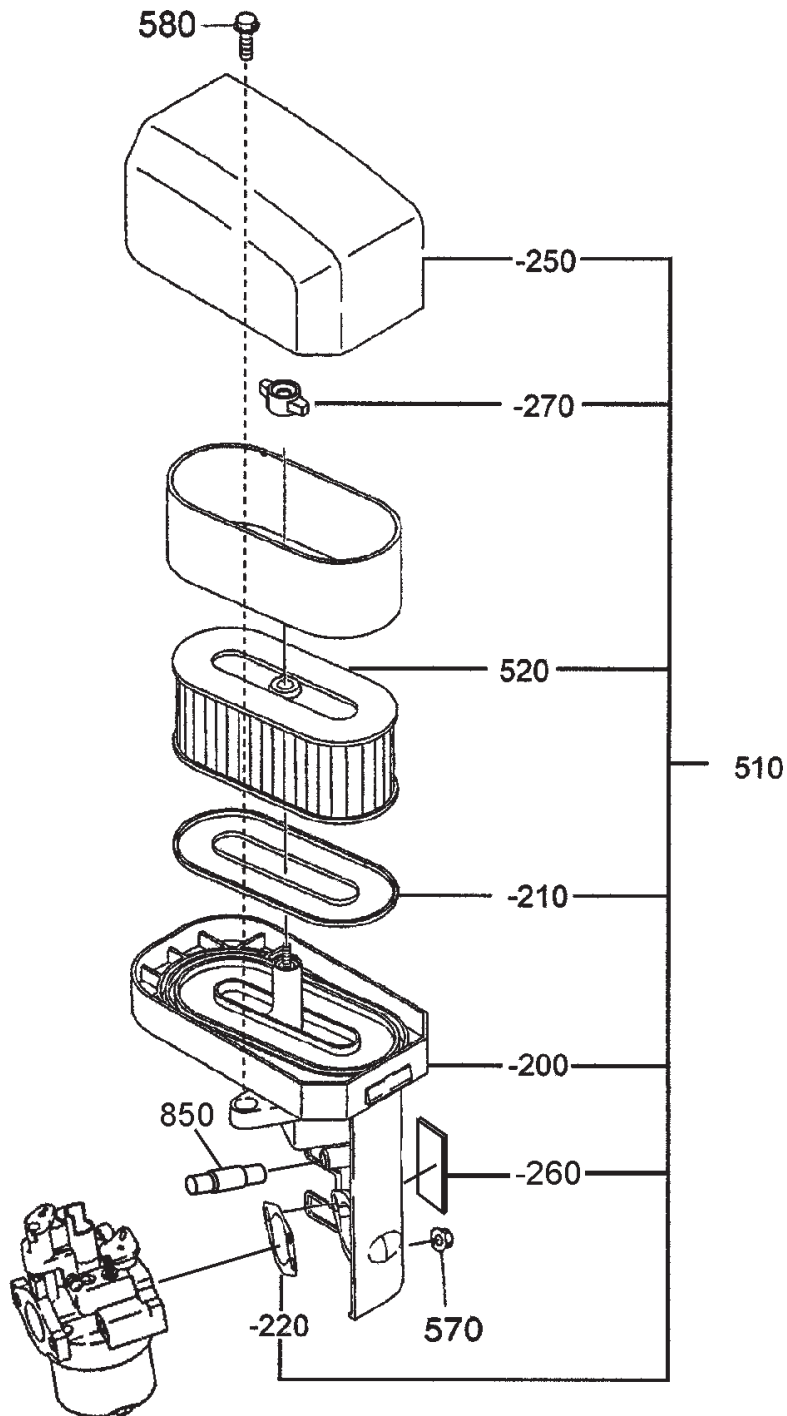

CARBURETOR  
REFERENCE  
ONLY

# ROBIN EX270D50220 ENGINE — AIR CLEANER ASSY.

## AIR CLEANER ASSY.

<u>NO.</u>	<u>PART NO.</u>	<u>PART NAME</u>	<u>QTY.</u>	<u>REMARKS</u>
510	2793261200	AIR CLEANER ASSY., DUAL .....	1 .....	INCLUDES ITEM W/*
510-200*	2793263108	BASE CP	1	
510-210*	2793263108	PACKING	1	
510-220*	2793265008	GASKET	1	
510-250*	2793264008	COVER	1	
510-260*	2793273008	LABEL	1	
510-270*	2793274008	NUT	1	
510-520*	2793260707	ELEMENT	1	
570	0023806000	FLANGE NUT	2	
580	0110060050	FLANGE BOLT	1	
850	0851080000	RUBBER PIPE, 8DX11D	1	

# ROBIN EX270D50220 ENGINE — CAMSHAFT ASSY.

CAMSHAFT ASSY.

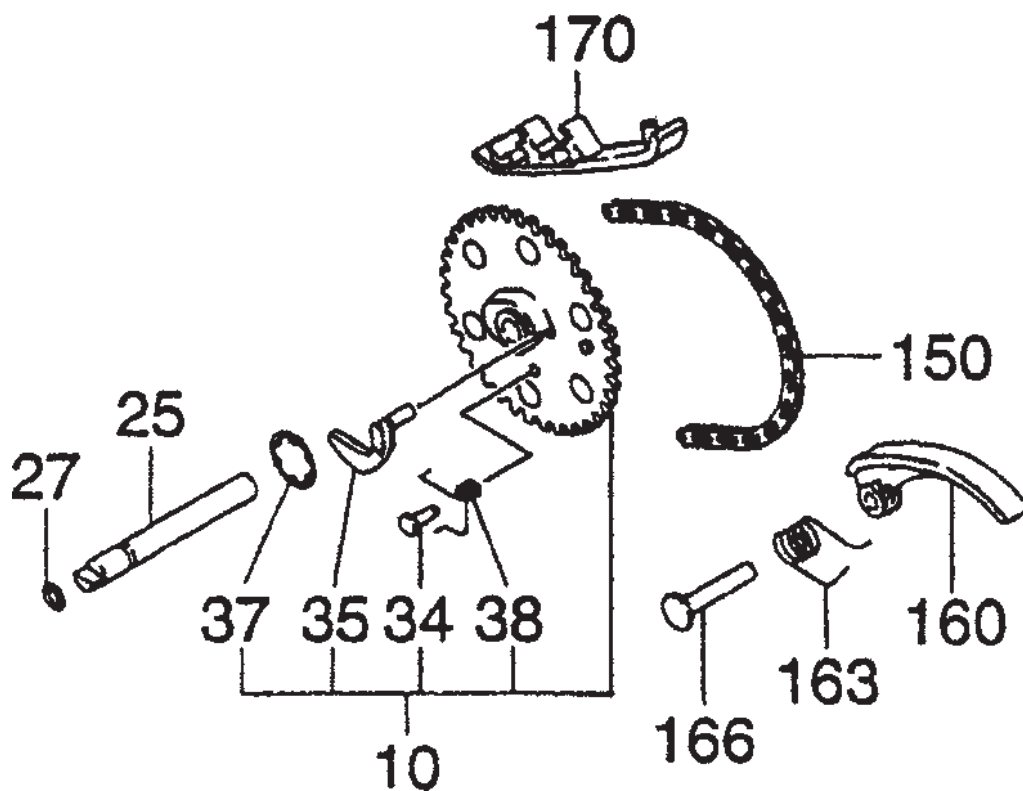

# ROBIN EX270D50220 ENGINE — CAMSHAFT ASSY.

## CAMSHAFT ASSY.

<u>NO.</u>	<u>PART NO.</u>	<u>PART NAME</u>	<u>QTY.</u>	<u>REMARKS</u>
10	2793160101	CAMSHAFT CP .....	1 .....	INCLUDES ITEMS W/ *
25	2773510103	PIN, CAMSHAFT, 9DX78.5L	1	
27	0240060010	O RING, 5.8DX9.6DX1.9T	1	
34*	2773860103	SPRING PIN, 4DX7.5DX11L	1	
35*	2793640103	RELEASE LEVER	1	
37*	2773650103	CLIP, 13.8DX20.3DX0.4T	1	
38*	2773870103	RETURN SPRING	1	
150	2793560101	TIMING CHAIN CP, 100 LINK	1	
160	2773691103	TENSIONER	1	
163	2773710103	SPRING, TENSIONER	1	
166	2773690203	PIN, TENSIONER, 6DX13DX34L	1	
170	2773691313	CHAIN GUIDE	1	

# ROBIN EX270D50220 ENGINE — CARBURETOR ASSY.

CARBURETOR ASSY.

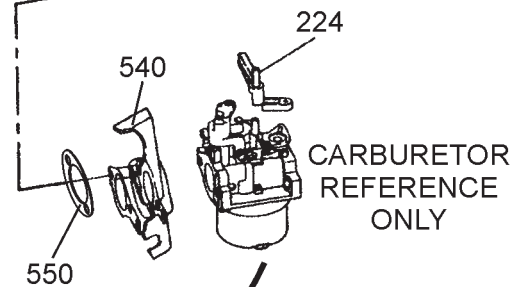
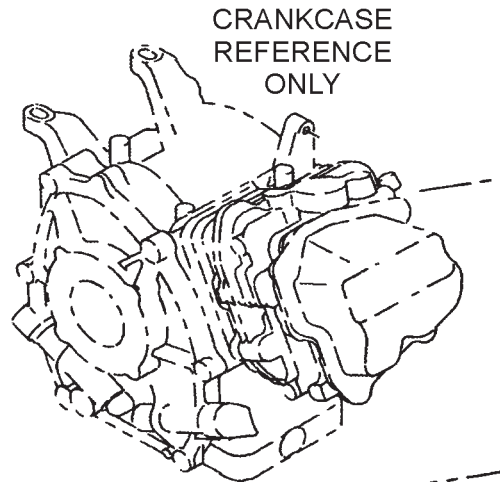
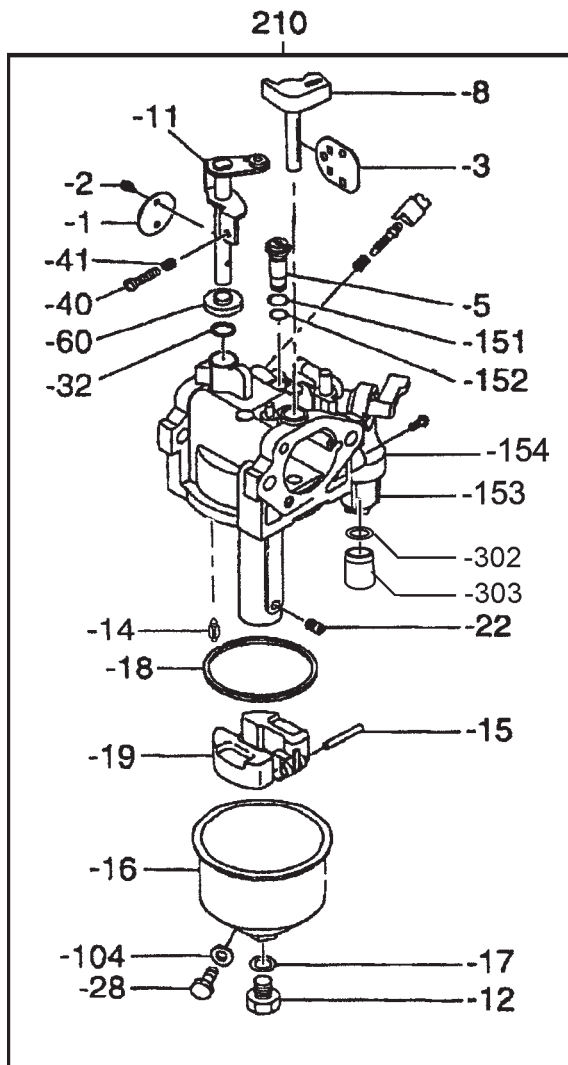

# ROBIN EX270D50220 ENGINE — CARBURETOR ASSY.

## CARBURETOR ASSY.

<u>NO.</u>	<u>PART NO.</u>	<u>PART NAME</u>	<u>QTY.</u>	<u>REMARKS</u>
210	2796230200	CARBURETOR ASSY. ....	1	INCLUDES ITEM W/*
210-1*	2796253508	VALVE THROTTLE	1	
210-2*	2516245008	SCREW	2	
210-3*	2796252508	VALVE CHOKE	1	
210-5*	2796242008	JET SLOW	1	
210-8*	2796252008	SHAFT CHOKE	1	
210-11*	2796253008	SHAFT SUB ASSY. THROTTLE	1	
210-12*	2516245308	SCREW	1	
210-14	2796250008	VALVE ASSY NEEDLE	1	
210-15*	2796251508	PIN FLOAT LEVER	1	
210-16*	2796255008	CHAMBER FLOAT	1	
210-17*	2516235008	GASKET	1	
210-18*	2796254008	GASKET CHAMBER	1	
210-19*	2796250508	FLOAT, CHAMBER	1	
210-22*	2796240108	JET MAIN	1	
210-28*	2796235508	SCREW DRAIN	1	
210-32*	2796256108	BUSH	1	
210-40*	2796235308	SCREW ADJUSTING	1	
210-41*	2796244508	SPRING	1	
210-60*	2796256208	COLLAR	1	
210-104*	2796255208	GASKET	1	
210-151*	2796245208	O-RING	1	
210-152*	2796245108	O-RING	1	
210-302*	0642006410	PACKING, FILTER CUP	1	
210-303*	0642007810	FILTER CUP	1	
224	2774380101	CHOKE LEVER CP	1	
540	2793290113	INSULATOR	1	
550	2793590123	GASKET, INSULATOR	1	

# ROBIN EX270D50220 ENGINE — CRANKCASE ASSY.

CRANKCASE ASSY.

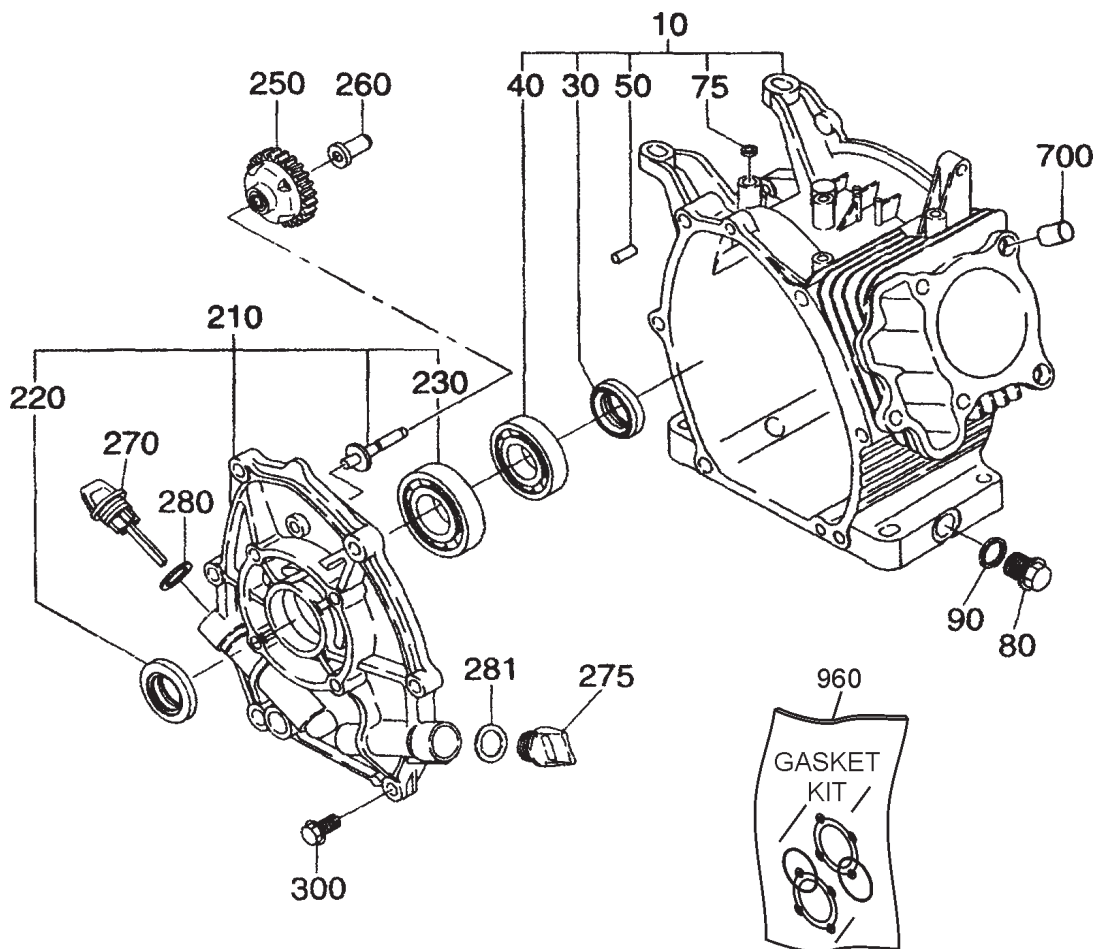

# ROBIN EX270D50220 ENGINE — CRANKCASE ASSY.

## CRANKCASE ASSY.

<u>NO</u>	<u>PART NO</u>	<u>PART NAME</u>	<u>QTY.</u>	<u>REMARKS</u>
10	2791010221	CRANKCASE CP, W/ OIL SENSOR .....	1	INCLUDES ITEMS W/ *
30*	0440300160	OIL SEAL, 28.8DX45DX7T	1	
40*	0600300340	BALL BEARING, BB6206, 30DX62DX16B	1	
50*	2771501103	PIPE KNOCK, 10DX8.5DX14L	2	
75*	0440060020	OIL SEAL, 5.6DX10DX2.5T	1	
80	0401140030	PLUG, M14X1.5 X20DX12L	2	
90+	0211140020	GASKET, 14.1DX19DX2.3T	2	
210	2791100201	MAIN BEARING COVER C .....	1	INCLUDES ITEMS W/ \$
220\$	0440300160	OIL SEAL, 28.8DX45DX7T	1	
230\$	0600300020	BALL BEARING	1	
250	2774500421	GOVERNOR GEAR CP, 52.5DX29T N=33	1	
260	2634190103	GOVERNOR SLEEVE, 6DX7.6DX16DX26L	1	
270	2796360103	OIL GAUGE, M22X1.5 L=67.5+18	1	
275	2796500103	FILLER PLUG, M22X1.5 L=12+18	1	
280+	0213200050	GASKET	1	
281	0213200050	GASKET	1	
300	0010408350	FLANGE BOLT	6	
700	2771501103	PIPE KNOCK, 10DX8.5DX14L	2	
960	2799900107	GASKET SET .....	1	INCLUDES ITEMS W/+ & ITEMS 620 & 690 IN THE CYLINDER HEAD ASSY

# ROBIN EX270D50220 ENGINE — CRANKSHAFT/PISTON ASSY.

CRANKSHAFT, PISTON ASSY.

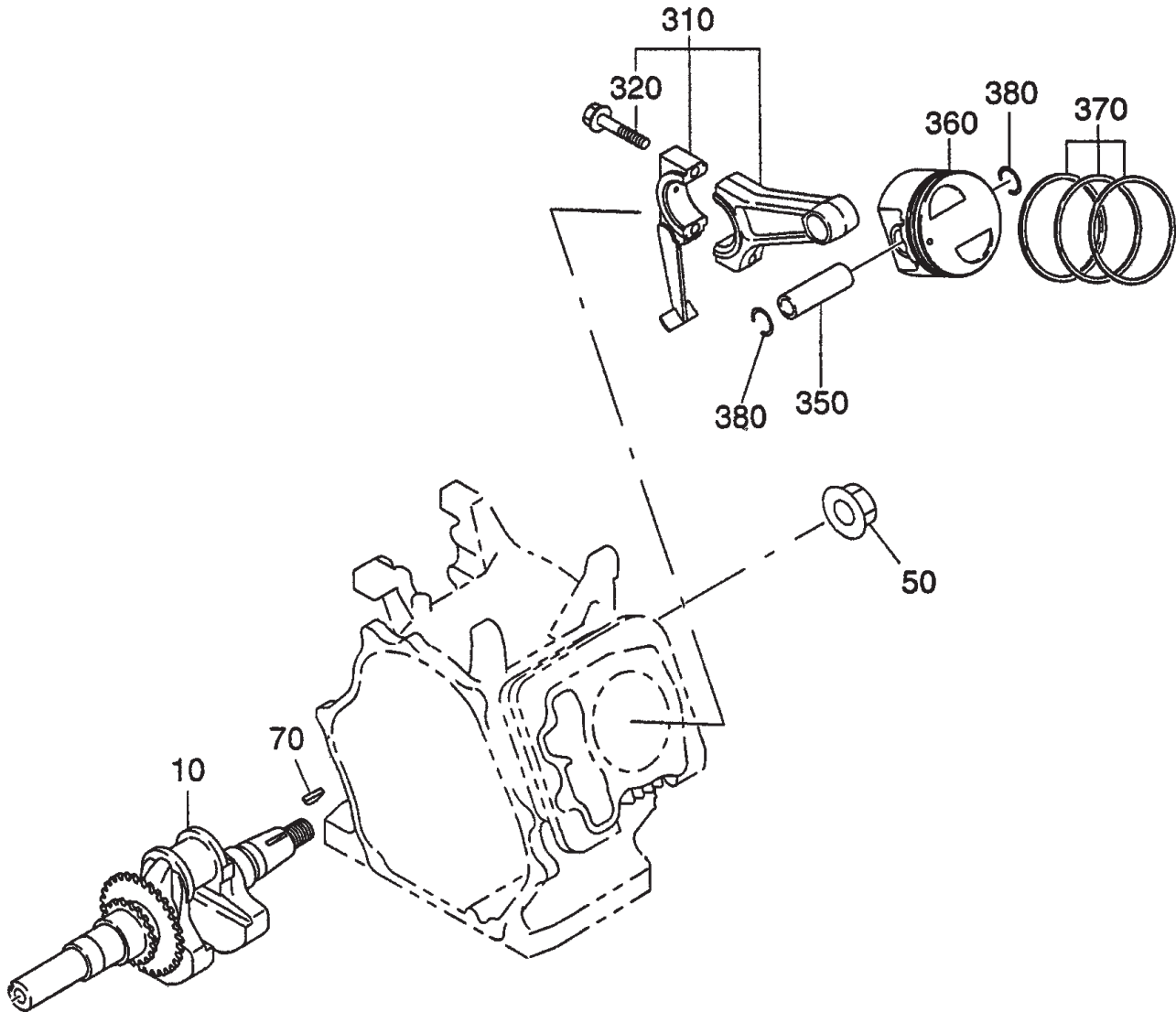

# ROBIN EX270D50220 ENGINE — CRANKSHAFT/PISTON ASSY.

CRANKSHAFT, PISTON ASSY.

<u>NO</u>	<u>PART NO</u>	<u>PART NAME</u>	<u>QTY.</u>	<u>REMARKS</u>
10	2792090111	CRANKSHAFT CP	1	
50	0180180010	FLANGE NUT, M18X31DX14H	1	
70	0323030010	WOODRUFF KEY, 3BX6HX16D	1	
310	2792250120	CONNECTING ROD ASSY. ....	1	INCLUDES ITEM W/#
320#	2792300103	CONNECTING ROD BOLT, M7X1.0X40L	2	
350	2792330103	PISTON PIN, 18DX13DX53L	1	
360	2792340103	PISTON, STD. 74.4DX43H	1	
360	2792340303	PISTON, OVERSIZE 0.25 MM	1	
360	2792340403	PISTON, OVERSIZE 0.50 MM	1	
370	2792351107	PISTON RING SET, STD.	1	
370	2792351207	PISTON RING SET, OVERSIZE 0.25 MM	1	
370	2792351307	PISTON RING SET, OVERSIZE 0.50 MM	1	
380	0565180010	CLIP, 17.3DX1.6D	2	

# ROBIN EX270D50220 ENGINE — CYLINDER HEAD ASSY.

CYLINDER HEAD ASSY.

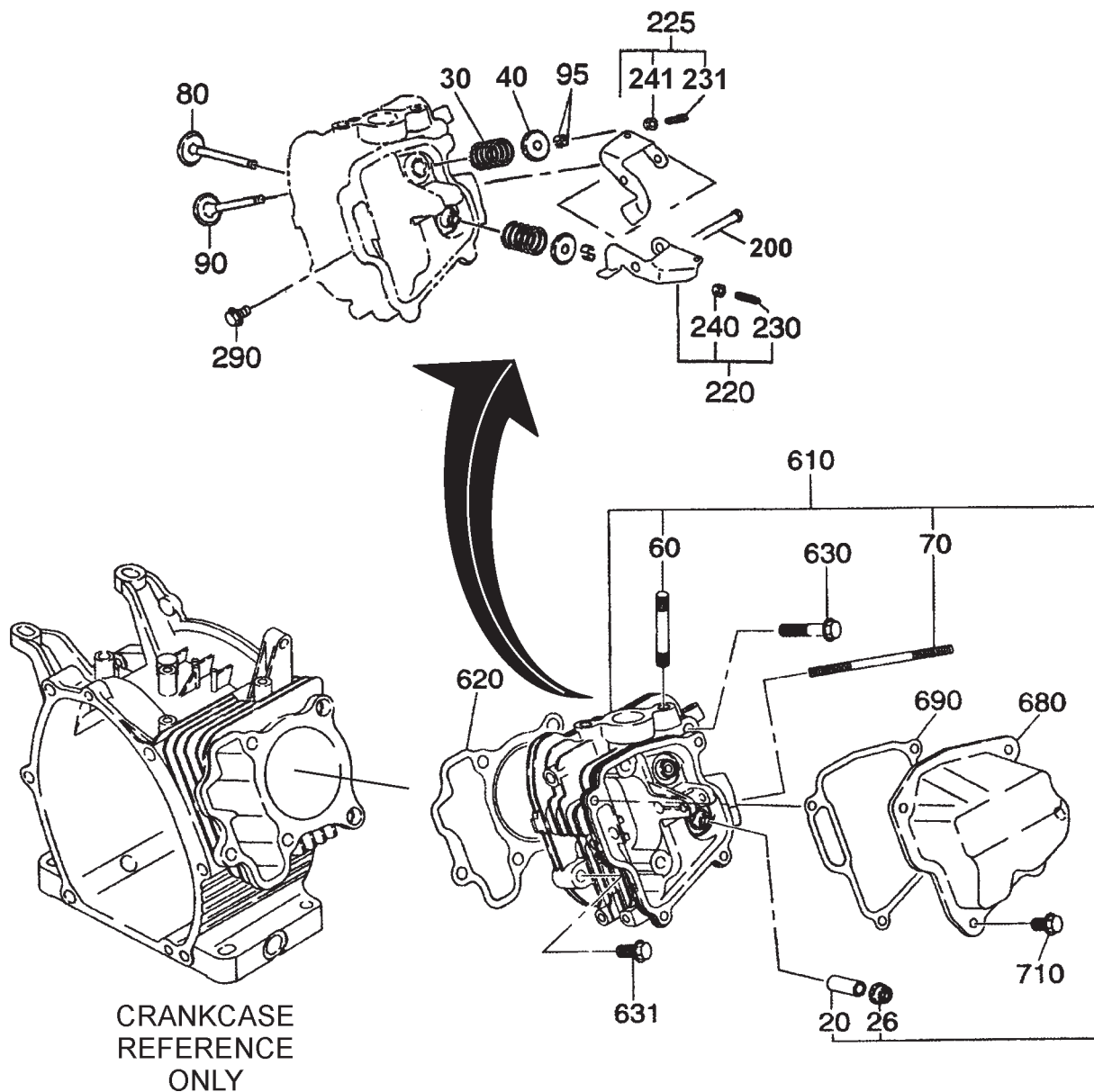

# ROBIN EX270D50220 ENGINE — CYLINDER HEAD ASSY.

## CYLINDER HEAD ASSY.

<u>NO.</u>	<u>PART NO.</u>	<u>PART NAME</u>	<u>QTY.</u>	<u>REMARKS</u>
20#	2371420203	VALVE GUIDE,5.5DX9.5DX27L	2	
26#	2771601001	STEM SEAL, 5DX11.6DX15DX7.8T	1	
30	2793360103	VALVE SPRING, 17DX2.3DX27L N=5.8	2	
40	2693370103	SPRING RETAINER	2	
60#	0105080250	STUD, M8X1.25X25L	2	
70#	0105060410	STUD, M6X1.0X107L	2	
80	2793340113	INTAKE VALVE, 28.5DX5.5DX67.8L	1	
90	2793350113	EXHAUST VALVE, 26.5DX5.5DX67.8L	1	
95	13210KA031	COLLET VALVE	4	
200	2773500103	PIN, ROCKER, 6DX9DX41L	1	
220	2773610100	ROCKER ARM ASSY. IN .....	1	INCLUDES ITEMS W/ *
225	2773610200	ROCKER ARM ASSY. EX .....	1	INCLUDES ITEMS W/ %
230*	0149050010	ADJUST SCREW, M5X0.5X23L	1	
231%	0149050010	ADJUST SCREW, M5X0.5X23L	1	
240*	0170050020	NUT, M5X0.5X4.1H	1	
241%	0170050020	NUT, M5X0.5X4.1H	1	
290	0110060020	FLANGE BOLT, M6X1.0X12L	1	
610	2791300101	CYLINDER HEAD CP .....	1	INCLUDES ITEM W/ #
620	2791500113	GASKET, HEAD	1	
630	0110080240	FLANGE BOLT, M8X1.25 X68L	4	
631	0010408350	FLANGE BOLT	1	
680	2771550101	ROCKER COVER CP	1	
690	2771600103	GASKET, ROCKER COVER, T=0.7	1	
710	0110060020	FLANGE BOLT, M6X1.0X12L	4	

# ROBIN EX270D50220 ENGINE — FUEL TANK ASSY.

FUEL TANK ASSY.

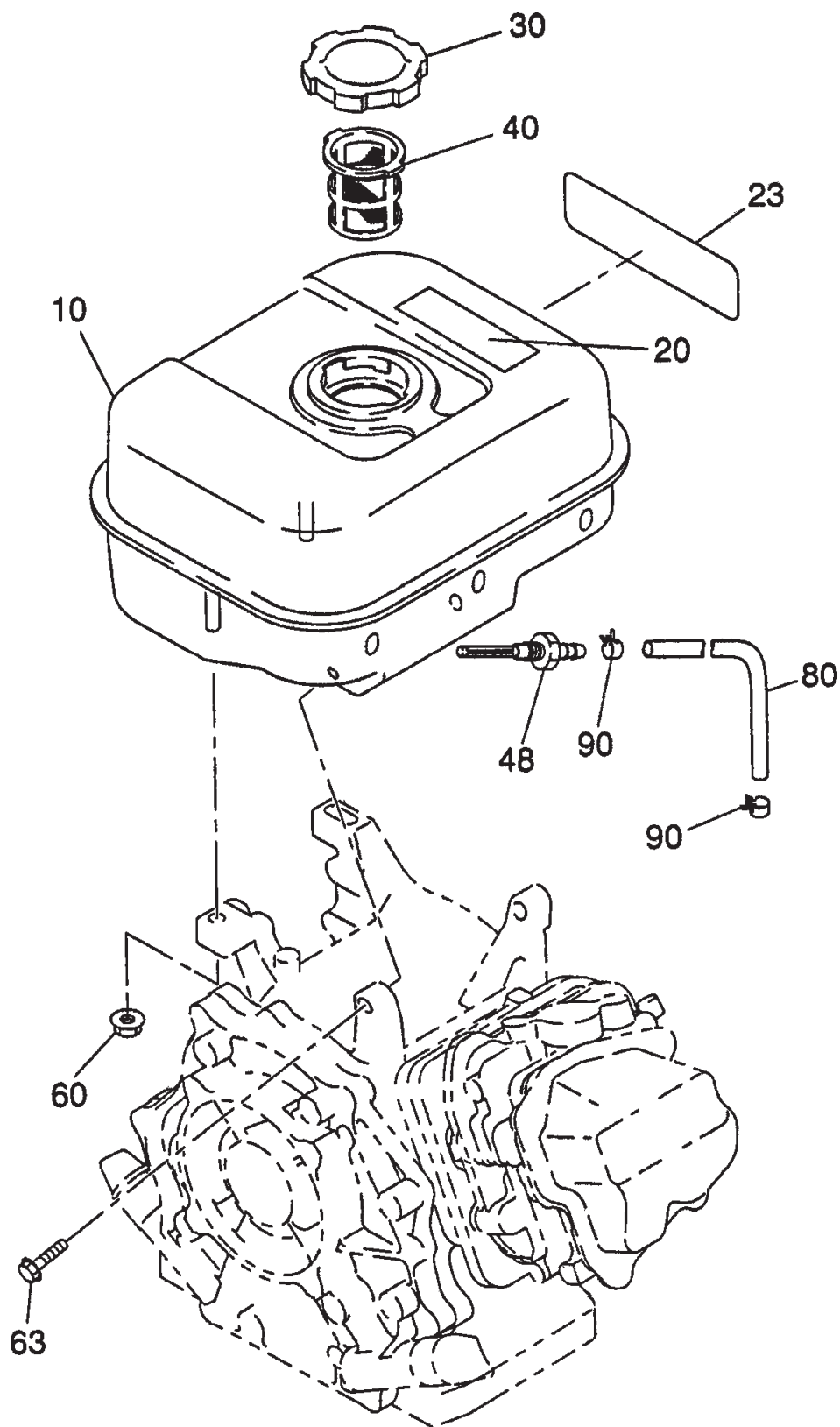

## ROBIN EX270D50220 ENGINE — FUEL TANK ASSY.

### FUEL TANK ASSY.

<u>NO.</u>	<u>PART NO.</u>	<u>PART NAME</u>	<u>QTY.</u>	<u>REMARKS</u>
10	2796010211	FUEL TANK CP, 3.6L BLACK	1	
20	0732005180	LABEL, WARNING	1	
23	2799510103	LABEL, MODEL	1	
30	0430440050	FUEL TANK CAP CP	1	
40	0641360010	FUEL, FILTER	1	
48	0505120020	UNION	1	
60	0023808000	FLANGE NUT	2	
63	0110080250	FLANGE BOLT, M8X1.25X25L	1	
80	0851060000	RUBBER PIPE, 6DX12D	1	
90	0561100030	HOSE CLAMP, 10DX8BX1T	2	
224	2774380101	CHOKE LEVER CP	1	

# ROBIN EX270D50220 ENGINE — GOVERNOR ASSY.

GOVERNOR ASSY.

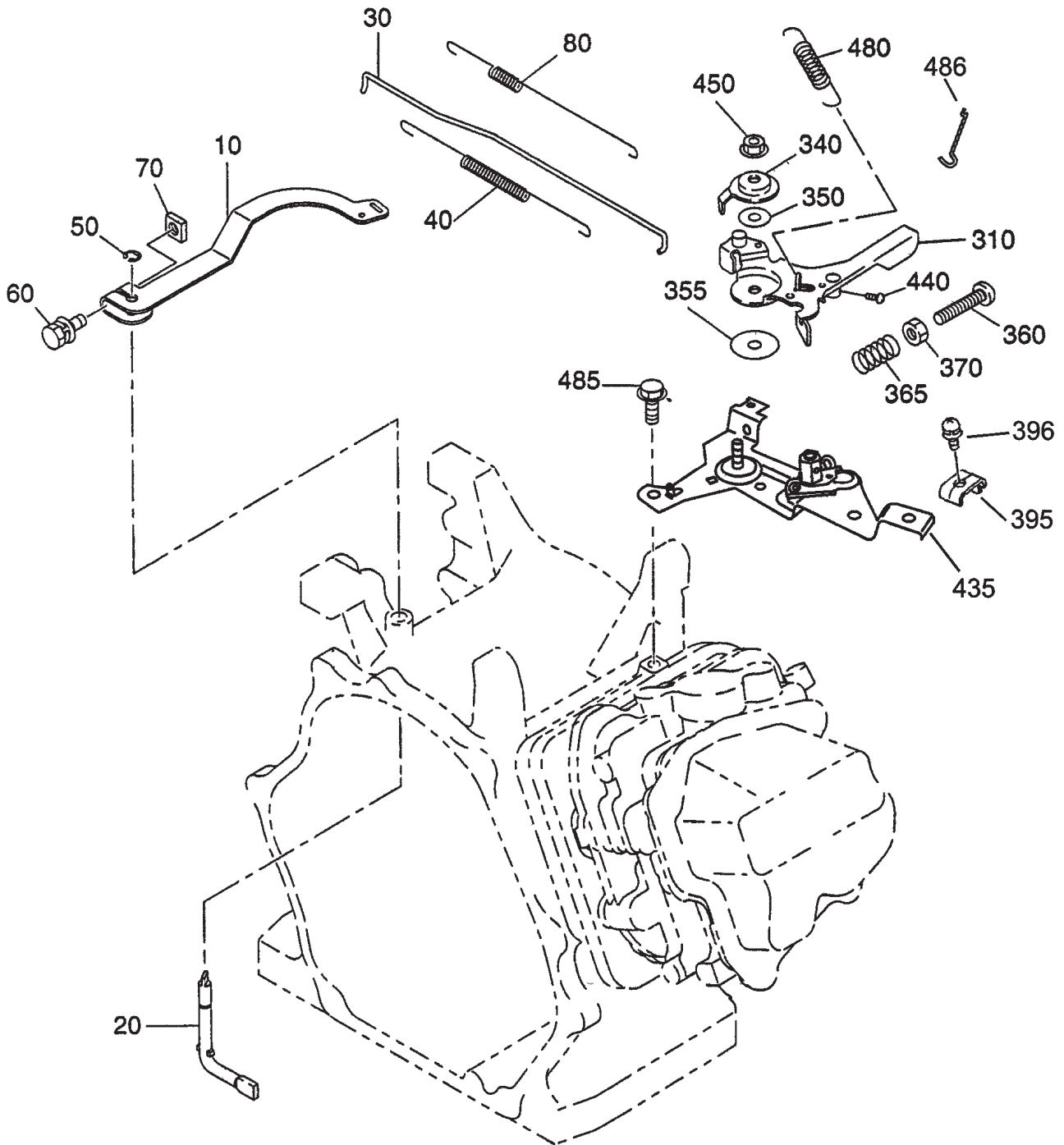

# ROBIN EX270D50220 ENGINE — GOVERNOR ASSY.

## GOVERNOR ASSY.

<u>NO.</u>	<u>PART NO.</u>	<u>PART NAME</u>	<u>QTY.</u>	<u>REMARKS</u>
10	2794230113	GOVERNOR LEVER	1	
20	2774220113	GOVERNOR SHAFT	1	
30	2794270101	GOVERNOR ROD CP.	1	
40	2774280113	ROD SPRING, 7DX0.5DX182L N=16	1	
50	0031305000	CLIP	2	
60	0130060240	BOLT AND WASHER ASSY.	1	
70	0186060020	NUT	1	
80	2794250223	GOVERNOR SPRING	1	
310	2794330201	SPEED CONTROL LEVER	1	
340	2774350103	STOP PLATE	1	
350	0200060170	WASHER, 6DX24DX2T	1	
355	0217060070	FRICTION WASHER, 6.5DX24DX0.8T	1	
360	0140060180	SCREW, M6X1.0X35L	1	
365	2374500423	SPRING, ADJUST	1	
370	0021706000	NUT	1	
395	2774390103	CLAMP	1	
396	0043605160	SCREW & WASHER ASSY.	1	
435	2774600101	SPEED CONTROL BRACKET CP	1	
440	0043104080	SCREW	1	
450	0023506000	SELF LOCK NUT	1	
480	2774510103	RETURN SPRING	1	
485	0110060020	FLANGE BOLT, M6X1.0X12L	2	

# ROBIN EX270D50220 ENGINE — IGNITION COIL/FLYWHEEL ASSY.

IGNITION/FLYWHEEL ASSY.

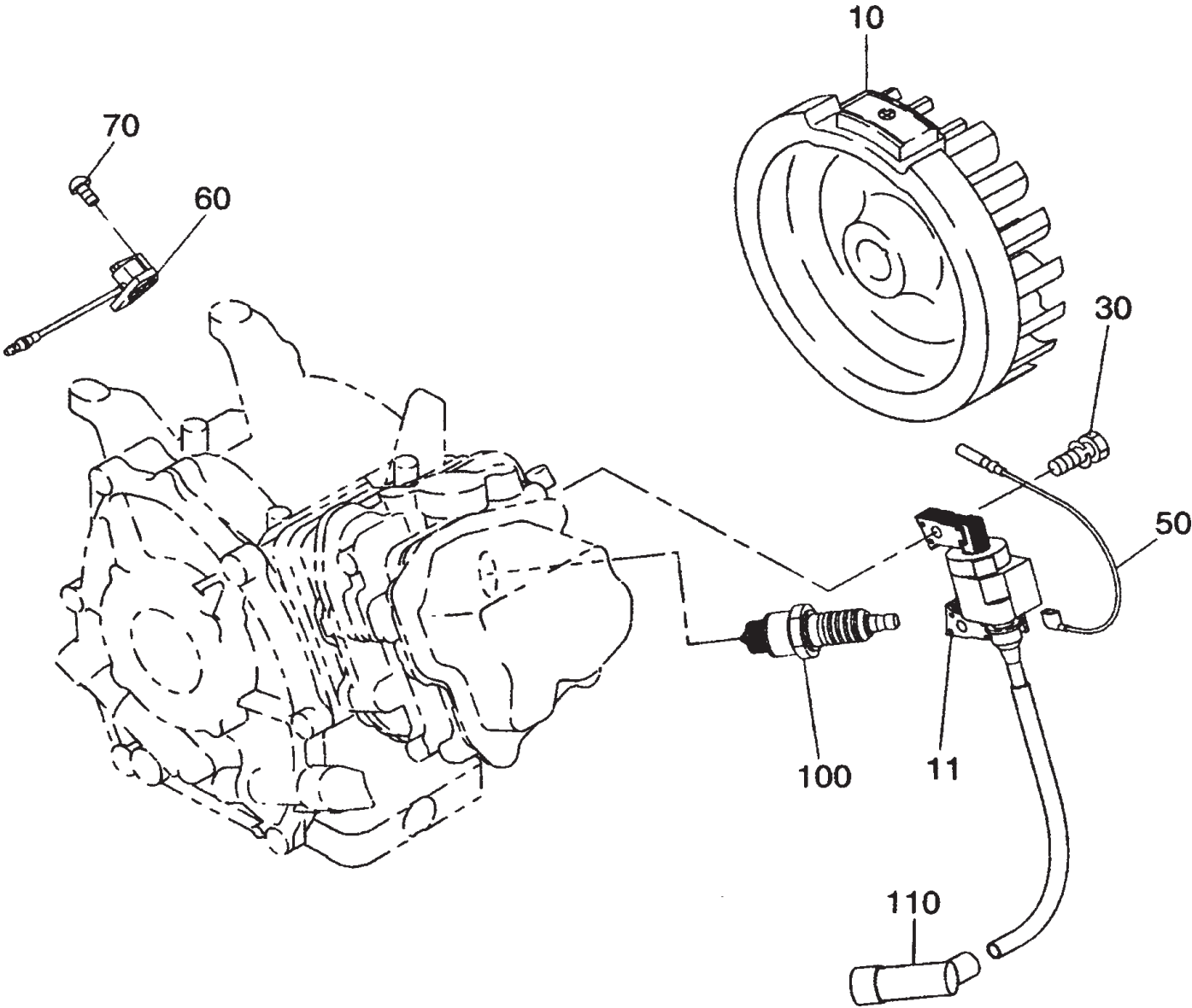

## ROBIN EX270D50220 ENGINE — IGNITION COIL/FLYWHEEL ASSY.

IGNITION/FLYWHEEL ASSY.

<u>NO</u>	<u>PART NO</u>	<u>PART NAME</u>	<u>QTY.</u>	<u>REMARKS</u>
10	2797923001	FLYWHEEL CP, 15W, 40W CHARGING	1	
11	2797943001	IGNITION COIL CP	1	
30	0011406250	BOLT & WASHER ASSY.	2	
50	27773101H1	WIRE 1 CP	1	
60	KU31107101	FLOAT C/U CP5	1	
70	0150040090	TAPPING SCREW, M4X10L	2	
100	0650140150	SPARK PLUG, NGK BR6HS	1	
110	0655000270	SPARK PLUG CAP	1	

# ROBIN EX270D50220 ENGINE — MUFFLER ASSY.

MUFFLER ASSY.

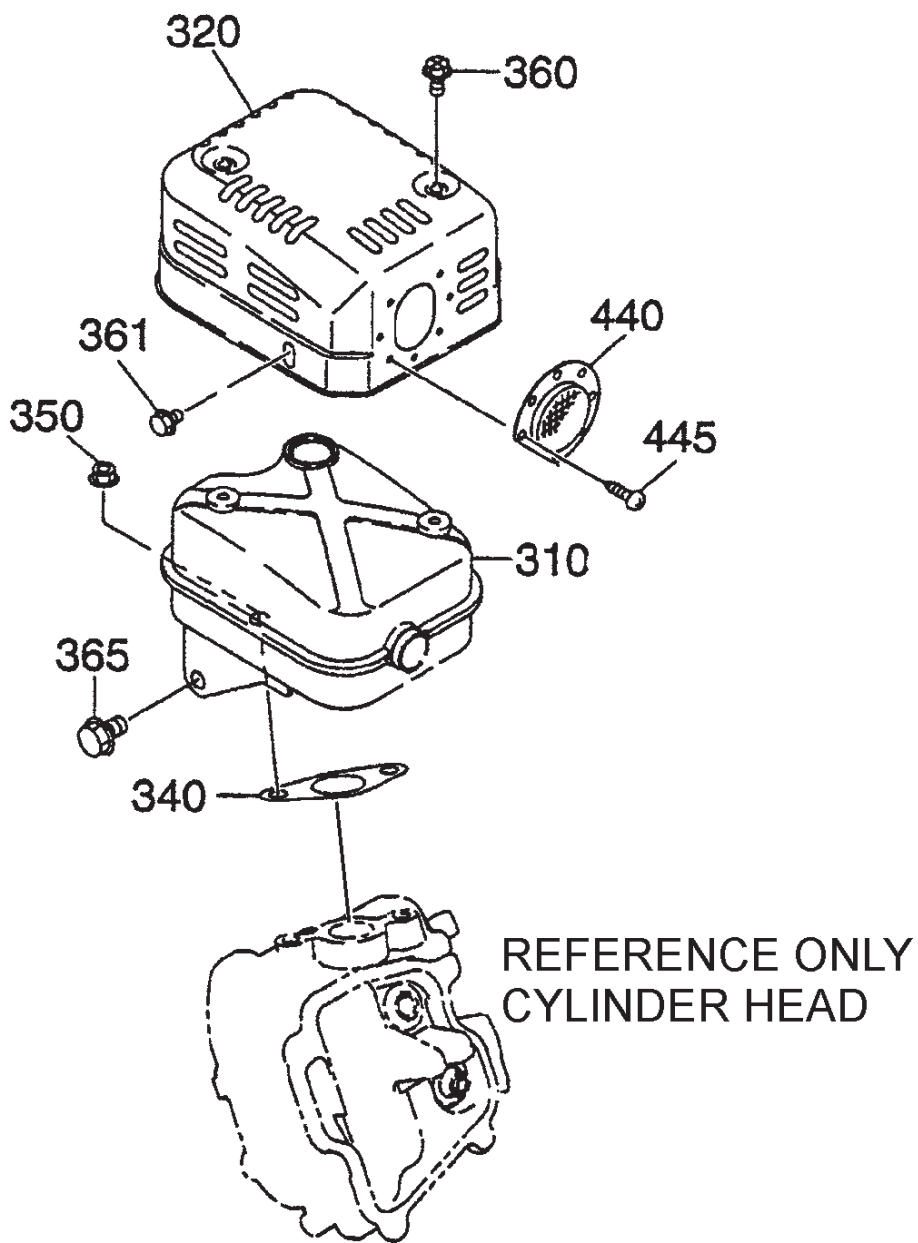

## ROBIN EX270D50220 ENGINE — MUFFLER ASSY.

### MUFFLER ASSY.

NO	PART NO	PART NAME	QTY.	REMARKS
310	2793010121	MUFFLER CP	1	
320	2793420111	MUFFLER COVER	1	
340	2773520103	GASKET, MUFFLER	1	
350	9802008280	FLANGE, NUT	2	
360	0152060090	TAPPING BOLT	2	
361	0110060010	FLANGE BOLT	1	
365	0110080150	FLANGE BOLT	1	
440	27737203H1	SCREEN CP	1	
445	0150040060	TAPPING SCREW	2	

# ROBIN EX270D50220 ENGINE — OIL SENSOR ASSY.

OIL SENSOR ASSY.

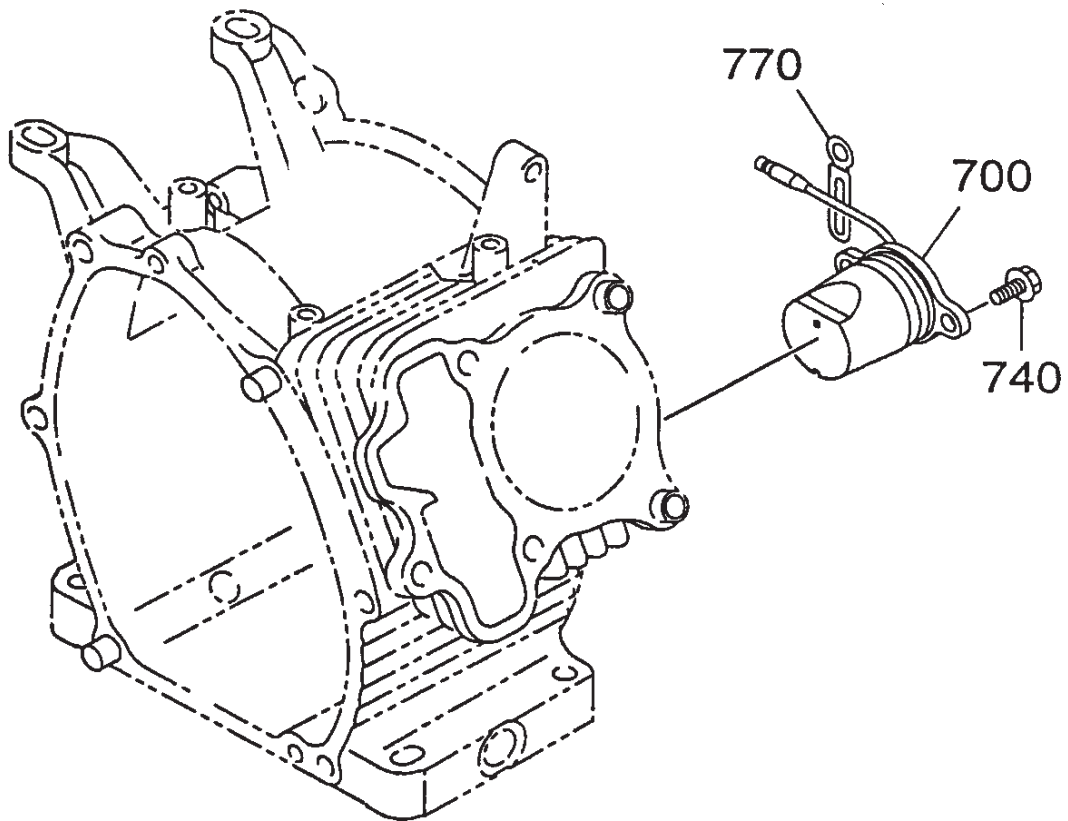

# ROBIN EX270D50220 ENGINE — OIL SENSOR ASSY.

OIL SENSOR ASSY.

NO	PART NO	PART NAME	QTY.	REMARKS
700	2797630121	OIL SENSOR CP	1	
740	0011406160	BOLT AND WASHER ASSY	2	
770	2077500101	CLAMP CP	1	

# ROBIN EX270D50220 ENGINE — RECOIL STARTER ASSY.

RECOIL STARTER ASSY.

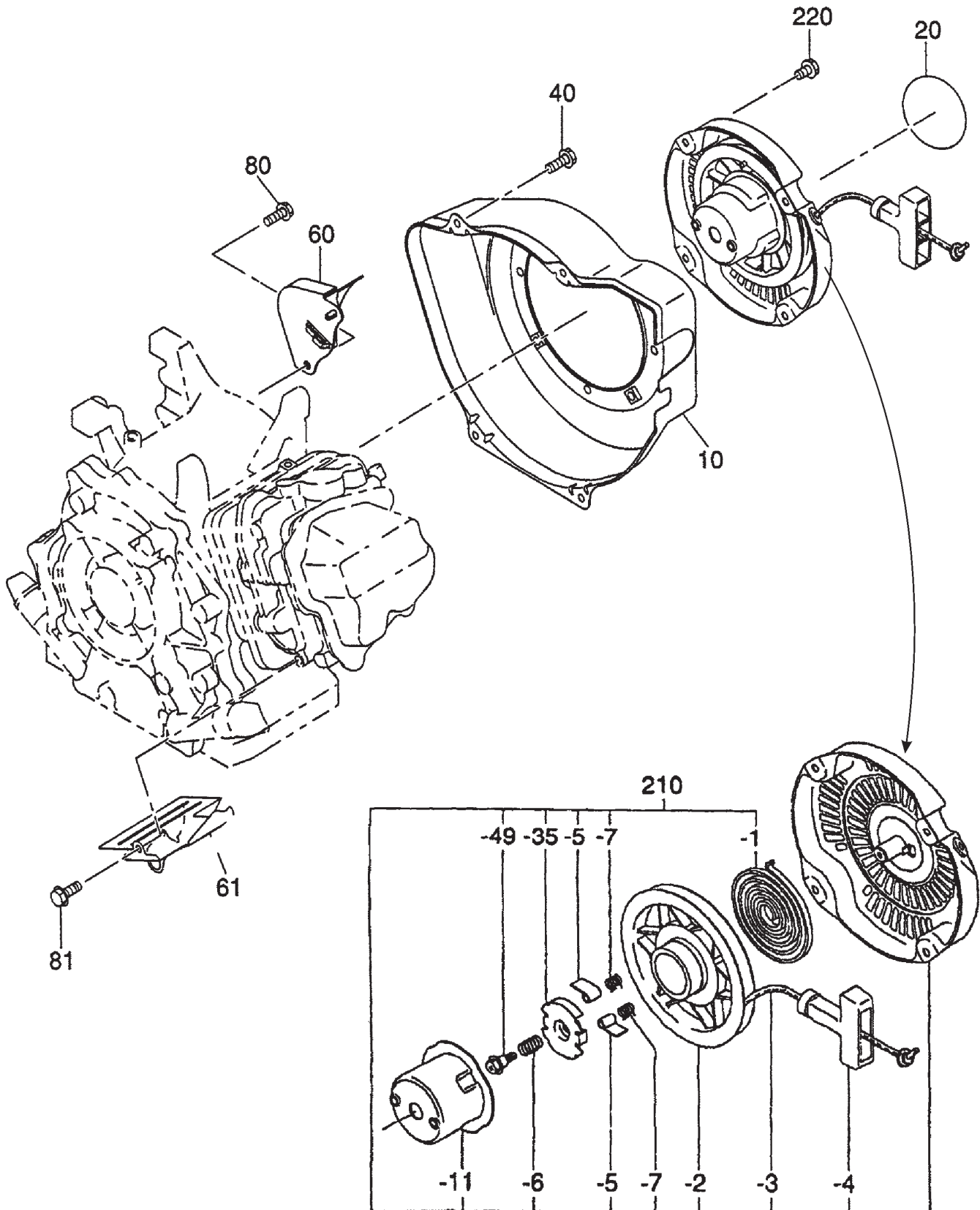

# ROBIN EX270D50220 ENGINE — RECOIL STARTER ASSY.

## RECOIL STARTER ASSY.

<u>NO.</u>	<u>PART NO.</u>	<u>PART NAME</u>	<u>QTY.</u>	<u>REMARKS</u>
10	2795120201	BLOWER HOUSING CP, BLACK	1	
20	0732005140	LABEL, TRADE MARK 64D	1	
40	0110060030	FLANGE BOLT, M6X1.0X14DX14L	4	
60	2795271111	BAFFLE 1, CASE CP	1	
61	2795270203	BAFFLE 2, HEAD	1	
80	0016508120	BOLT	1	
81	0110060020	FLANGE BOLT, M6X1.0X14DX12L	1	
210	2795020200	RECOIL STARTER ASSY., D-STD. ....	1	INCLUDES ITEM W/*
210-1*	2265071608	SPIRAL SPRING	1	
210-2*	2795012008	REEL	1	
210-3*	2795011008	STARTER ROPE	1	
210-4*	2265070108	STARTER KNOB	1	
210-5*	2795012508	RATCHET	2	
210-6*	2265073108	FRICITION SPRING	1	
210-7	2265075208	RATCHET SPRING	2	
210-11*	2795014508	STARTER PULLEY	1	
210-35*	2265074108	FRICITION PLATE	1	
210-49*	2265075318	CENTER SCREW	1	
220	0110060010	FLANGE BOLT, M6X1.0XX14DX8L	4	

**PAYMENT TERMS**

Terms of payment for parts are net 10 days.

**FREIGHT POLICY**

All parts orders will be shipped collect or prepaid with the charges added to the invoice. All shipments are F.O.B. point of origin. Multiquip's responsibility ceases when a signed manifest has been obtained from the carrier, and any claim for shortage or damage must be settled between the consignee and the carrier.

**MINIMUM ORDER**

The minimum charge for orders from Multiquip is \$15.00 net. Customers will be asked for instructions regarding handling of orders not meeting this requirement.

**RETURNED GOODS POLICY**

Return shipments will be accepted and credit will be allowed, subject to the following provisions:

1. A Returned Material Authorization must be approved by Multiquip prior to shipment.
2. To obtain a Return Material Authorization, a list must be provided to Multiquip Parts Sales that defines item numbers, quantities, and descriptions of the items to be returned.
  - a. The parts numbers and descriptions must match the current parts price list.
  - b. The list must be typed or computer generated.
  - c. The list must state the reason(s) for the return.
  - d. The list must reference the sales order(s) or invoice(s) under which the items were originally purchased.
  - e. The list must include the name and phone number of the person requesting the RMA.
3. A copy of the Return Material Authorization must accompany the return shipment.
4. Freight is at the sender's expense. All parts must be returned freight prepaid to Multiquip's designated receiving point.
5. Parts must be in new and resalable condition, in the original Multiquip package (if any), and with Multiquip part numbers clearly marked.
6. The following items are not returnable:
  - a. Obsolete parts. (If an item is in the price book and shows as being replaced by another item, it is obsolete.)
  - b. Any parts with a limited shelf life (such as gaskets, seals, "O" rings, and other rubber parts) that were purchased more than six months prior to the return date.
  - c. Any line item with an extended dealer net price of less than \$5.00.
  - d. Special order items.
  - e. Electrical components.
  - f. Paint, chemicals, and lubricants.
  - g. Decals and paper products.
  - h. Items purchased in kits.
7. The sender will be notified of any material received that is not acceptable.
8. Such material will be held for five working days from notification, pending instructions. If a reply is not received within five days, the material will be returned to the sender at his expense.
9. Credit on returned parts will be issued at dealer net price at time of the original purchase, less a 15% restocking charge.
10. In cases where an item is accepted, for which the original purchase document can not be determined, the price will be based on the list price that was effective twelve months prior to the RMA date.
11. Credit issued will be applied to future purchases only.

**PRICING AND REBATES**

Prices are subject to change without prior notice. Price changes are effective on a specific date and all orders received on or after that date will be billed at the revised price. Rebates for price declines and added charges for price increases will not be made for stock on hand at the time of any price change.

Multiquip reserves the right to quote and sell direct to Government agencies, and to Original Equipment Manufacturer accounts who use our products as integral parts of their own products.

**SPECIAL EXPEDITING SERVICE**

A \$35.00 surcharge will be added to the invoice for special handling including bus shipments, insured parcel post or in cases where Multiquip must personally deliver the parts to the carrier.

**LIMITATIONS OF SELLER'S LIABILITY**

Multiquip shall not be liable hereunder for damages in excess of the purchase price of the item with respect to which damages are claimed, and in no event shall Multiquip be liable for loss of profit or good will or for any other special, consequential or incidental damages.

**LIMITATION OF WARRANTIES**

No warranties, express or implied, are made in connection with the sale of parts or trade accessories nor as to any engine not manufactured by Multiquip. Such warranties made in connection with the sale of new, complete units are made exclusively by a statement of warranty packaged with such units, and Multiquip neither assumes nor authorizes any person to assume for it any other obligation or liability whatever in connection with the sale of its products. Apart from such written statement of warranty, there are no warranties, express, implied or statutory, which extend beyond the description of the products on the face hereof.



# PARTS AND OPERATION MANUAL

## HERE'S HOW TO GET HELP

PLEASE HAVE THE MODEL AND SERIAL  
NUMBER *ON-HAND* WHEN CALLING

### UNITED STATES

#### ***Multiquip Corporate Office***

18910 Wilmington Ave. Tel. (800) 421-1244  
Carson, CA 90746 Fax (800) 537-3927  
Contact: mq@multiquip.com

#### ***Mayco Parts***

800-306-2926 Fax: 800-672-7877  
310-537-3700 Fax: 310-637-3284

#### ***Service Department***

800-421-1244 Fax: 310-537-4259  
310-537-3700

#### ***MQ Parts Department***

800-427-1244 Fax: 800-672-7877  
310-537-3700 Fax: 310-637-3284

#### ***Warranty Department***

800-421-1244, Ext. 279 Fax: 310-537-1173  
310-537-3700, Ext. 279

#### ***Technical Assistance***

800-478-1244 Fax: 310-631-5032

### MEXICO

#### ***MQ Cipsa***

Carr. Fed. Mexico-Puebla KM 126.5 Tel: (52) 222-225-9900  
Momoxpan, Cholula, Puebla 72760 Mexico Fax: (52) 222-285-0420  
Contact: pmastretta@cipsa.com.mx

### CANADA

#### ***Multiquip***

4110 Industriel Boul. Tel: (450) 625-2244  
Laval, Quebec, Canada H7L 6V3 Fax: (450) 625-8664  
Contact: jmartin@multiquip.com

### UNITED KINGDOM

#### ***Multiquip (UK) Limited Head Office***

Hanover Mill, Fitzroy Street, Tel: 0161 339 2223  
Ashton-under-Lyne, Fax: 0161 339 3226  
Lancashire OL7 0TL  
Contact: sales@multiquip.co.uk

### BRAZIL

#### ***Multiquip***

Av. Evandro Lins e Silva, 840 - grupo 505 Tel: 011-55-21-3433-9055  
Barra de Tijuca - Rio de Janeiro Fax: 011-55-21-3433-9055  
Contact: cnavarro@multiquip.com.br, srentes@multiquip.com.br

© COPYRIGHT 2005, MULTIQUIP INC.

Multiquip Inc, the MQ logo are registered trademarks of Multiquip Inc. and may not be used, reproduced, or altered without written permission. All other trademarks are the property of their respective owners and used with permission.

This manual **MUST** accompany the equipment at all times. This manual is considered a permanent part of the equipment and should remain with the unit if resold.

The information and specifications included in this publication were in effect at the time of approval for printing. Illustrations are based on the *QP-4TE Trash Pump*. Illustrations, descriptions, references and technical data contained in this manual are for guidance only and may not be considered as binding. Multiquip Inc. reserves the right to discontinue or change specifications, design or the information published in this publication at any time without notice and without incurring any obligations.

Your Local Dealer is:

