

OPERATION AND PARTS MANUAL



Model V30-4 VIBRATORY ROLLER

© COPYRIGHT 2006, MULTIQUIP INC.

Revision #5 (09/22/06)



MULTIQUIP INC.

18910 WILMINGTON AVE.
CARSON, CALIFORNIA 90746
310-537-3700
800-421-1244
FAX: 310-537-3927

E-mail: mq@multiquip.com • www.multiquip.com

Atlanta • Boise • Dallas • Houston • Newark
Montreal, Canada • Manchester, UK
Rio De Janeiro, Brazil • Guadalajara, Mexico

PARTS DEPARTMENT:

800-427-1244
FAX: 800-672-7877

SERVICE DEPARTMENT/TECHNICAL ASSISTANCE:

800-478-1244
FAX: 310-631-5032



WARNING



CALIFORNIA — Proposition 65 Warning

Engine exhaust and some of its constituents, and some dust created by power sanding, sawing, grinding, drilling and other construction activities contains chemicals known to the State of California to cause cancer, birth defects and other reproductive harm. Some examples of these chemicals are:

- Lead from lead-based paints.
- Crystalline silica from bricks.
- Cement and other masonry products.
- Arsenic and chromium from chemically treated lumber.

Your risk from these exposures varies, depending on how often you do this type of work. To reduce your exposure to these chemicals: **ALWAYS** work in a well ventilated area, and work with approved safety equipment, such as dust masks that are specially designed to filter out microscopic particles.

HERE'S HOW TO GET HELP

*PLEASE HAVE THE MODEL AND SERIAL NUMBER
ON-HAND WHEN CALLING*

PARTS DEPARTMENT

800-427-1244 or 310-537-3700

FAX: 800-672-7877 or 310-637-3284

SERVICE DEPARTMENT/TECHNICAL ASSISTANCE

800-478-1244 or 310-537-3700

FAX: 310- 537-4259

WARRANTY DEPARTMENT

888-661-4279, or 310-661-4279

FAX: 310- 537-1173

MAIN

800-421-1244 or 310-537-3700

FAX: 310-537-3927

TABLE OF CONTENTS

Here's How To Get Help	3	Explanation Of Code In Remarks Column	34
Table Of Contents	4	Suggested Spare Parts	35
Parts Ordering Procedures	5	Name Plate and Decals	36-37
		Cocoa Mat Assy.	38-39
		Travel Linkage Assy.	40-41
		Vibratory Linkage	42-43
		Handle Assy.	44-45
		Chassis Assy.	46-47
		Transport Hooks Assy.	48-49
		Pump Drive Assy.	50-51
		Vibratory Drive Assy.	52-53
		Vibratory Roll Assy.	54-55
		Battery Assy.	56-57
		Spray Assy.	58-59
		Transmission Assy.	60-61
Multiquip V30-4 — Vibratory Roller			
Safety Message Alert Symbols	6-7		
Rules For Safe Operation	8-9		
Operation and Safety Decals	10		
Specifications	11		
Roller Dimensions	12-13		
Roller Components	14-16		
Roller Components	17-18		
General Information	19		
Inspection	20-22		
Initial Start-Up (Engine)	23-24		
Operation	25-26		
Maintenance	27-29		
Preparation For Long Term Storage	30		
Troubleshooting (Roller)	31		
Troubleshooting (Engine)	32-33		

NOTE

Specification and part number are subject to change without notice.

www.multiquip.com

**Ordering parts has never been easier!
Choose from three easy options:**



Order via Internet (Dealers Only):

Order parts on-line using Multiquip's SmartEquip website!

- View Parts Diagrams
- Order Parts
- Print Specification Information



If you have an MQ Account, to obtain a Username and Password, E-mail us at: parts@multiquip.com.

To obtain an MQ Account, contact your District Sales Manager for more information.

Goto www.multiquip.com and click on **Order Parts** to log in and save!

Use the *internet* and qualify for a **5% Discount** on *Standard orders* for all orders which include complete part numbers.*

Note: Discounts Are Subject To Change



Order via Fax (Dealers Only):

All customers are welcome to order parts via Fax.

Domestic (US) Customers dial:
1-800-6-PARTS-7 (800-672-7877)

Fax your order in and qualify for a **3% Discount** on *Standard orders* for all orders which include complete part numbers.*

Note: Discounts Are Subject To Change



Order via Phone: Domestic (US) Dealers Call:
1-800-427-1244

Non-Dealer Customers:

Contact your local Multiquip Dealer for parts or call 800-427-1244 for help in locating a dealer near you.



International Customers should contact their local Multiquip Representatives for Parts Ordering information.

When ordering parts, please supply:

- | | |
|--|--|
| <ul style="list-style-type: none"> <input type="checkbox"/> Dealer Account Number <input type="checkbox"/> Dealer Name and Address <input type="checkbox"/> Shipping Address (if different than billing address) <input type="checkbox"/> Return Fax Number <input type="checkbox"/> Applicable Model Number <input type="checkbox"/> Quantity, Part Number and Description of Each Part | <ul style="list-style-type: none"> <input type="checkbox"/> Specify Preferred Method of Shipment: <ul style="list-style-type: none"> <input checked="" type="checkbox"/> Fed Ex/UPS <input checked="" type="checkbox"/> DHL <input type="checkbox"/> Priority One <input checked="" type="checkbox"/> Truck <input type="checkbox"/> Ground <input type="checkbox"/> Next Day <input type="checkbox"/> Second/Third Day |
|--|--|

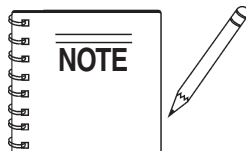

Unless otherwise indicated by customer, all orders are treated as *Standard Orders* and will ship within 24 hours. We will make every effort to ship *Air Shipments* the same day the order is received, if received prior to 2PM PST. *Stock Orders* must be noted on fax or web order form.

WE ACCEPT ALL MAJOR CREDIT CARDS!



V30-4 — SAFETY MESSAGE ALERT SYMBOLS

FOR YOUR SAFETY AND THE SAFETY OF OTHERS!

Safety precautions should be followed at all times when operating this equipment. Failure to read and understand the Safety Messages and Operating Instructions could result in injury to yourself and others.

NOTE

This Owner's Manual has been developed to provide complete instructions for the safe and efficient operation of the Multiquip Model V30-4 Vibratory Roller. Refer to the engine manufacturers instructions for data relative to its safe operation.

Before using this vibratory roller, ensure that the operating individual has read and understands all instructions in this manual.

SAFETY MESSAGE ALERT SYMBOLS

The three (3) Safety Messages shown below will inform you about potential hazards that could injure you or others. The Safety Messages specifically address the level of exposure to the operator, and are preceded by one of three words: **DANGER**, **WARNING**, or **CAUTION**.



DANGER: You **WILL** be **KILLED** or **SERIOUSLY** injured if you do not follow directions.



WARNING: You **CAN** be **KILLED** or **SERIOUSLY** injured if you do not follow directions.



CAUTION: You **CAN** be injured if you do not follow directions.

Potential hazards associated with V30-4 vibration roller operation will be referenced with Hazard Symbols which appear throughout this manual, and will be referenced in conjunction with Safety Message Alert Symbols.

HAZARD SYMBOLS



Lethal Exhaust Gases



Engine exhaust gases contain poisonous carbon monoxide. This gas is colorless and odorless, and can cause death if inhaled. **NEVER** operate this equipment in a confined area or enclosed structure that does not provide ample free flow air.



Explosive Fuel



GASOLINE is extremely flammable, and its vapors can cause an explosion if ignited. **DO NOT** start the engine near spilled fuel or combustible fluids. **DO NOT** fill the fuel tank while the engine is running or hot. **DO NOT** overfill tank, since spilled fuel could ignite if it comes into contact with hot engine parts or sparks from the ignition system. Store fuel in approved containers, in well-ventilated areas and away from sparks and flames. **NEVER** use fuel as a cleaning agent.



Burn Hazards



Engine components can generate extreme heat. To prevent burns, **DO NOT** touch these areas while the engine is running or immediately after operations. Never operate the engine with heat shields or heat guards removed.



Rotating Parts



NEVER operate equipment with covers, or guards removed. Keep fingers, hands, hair and clothing away from all moving parts to prevent injury.

V30-4 — SAFETY MESSAGE ALERT SYMBOLS



Accidental Starting



OFF

ALWAYS place the engine ON/OFF switch in the **OFF** position, and remove the ignition key when the machine is not in use.



Respiratory Hazard



ALWAYS wear approved respiratory protection.



Sight and Hearing hazard



ALWAYS wear approved eye and hearing protection.



Equipment Damage Messages

Other important messages are provided throughout this manual to help prevent damage to your trash pump, other property, or the surrounding environment.

NOTE

This compaction roller, other property, or the surrounding environment could be damaged if you do not follow instructions.

RULES FOR SAFE OPERATION

CAUTION:



Failure to follow instructions in this manual may lead to serious injury or even death! This equipment is to be operated by trained and qualified personnel only! This equipment is for industrial use only.

The following safety guidelines should always be used when operating the V30-4 Vibration Roller:

GENERAL SAFETY

- **DO NOT** operate or service this equipment before reading this entire manual.



- This equipment should not be operated by persons under 18 years of age.

- **NEVER** operate this equipment without proper protective clothing, shatterproof glasses, steel-toed boots and other protective devices required by the job.



- **NEVER** operate this equipment when not feeling well due to fatigue, illness or taking medicine.



- **NEVER** operate this equipment under the influence of drugs or alcohol.



- **NEVER** use accessories or attachments, which are not recommended by Multiquip for this equipment. Damage to the equipment and/or injury to user may result.

- Manufacture does not assume responsibility for any accident due to equipment modifications.

- Whenever necessary, replace nameplate, operation and safety decals when they become difficult read.

- **ALWAYS** check the machine for loosened threads or bolts before starting.

- **NEVER** touch the hot exhaust manifold, muffler or cylinder. Allow these parts to cool before servicing engine or pump.



- **High Temperatures** – Allow the engine to cool before adding fuel or performing service and maintenance functions. Contact with *hot* components can cause serious burns.

- The engine of this roller requires an adequate free flow of cooling air. Never operate the roller in any enclosed or narrow area where free flow of the air is restricted. If the air flow is restricted it will cause serious damage to the pump or engine and may cause injury to people and property. Remember the roller's engine gives off **DEADLY** gases.

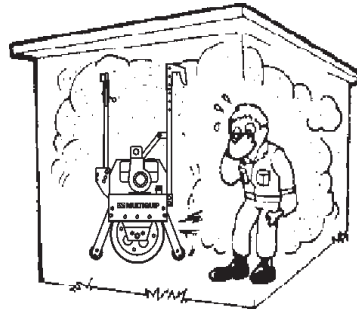

- **ALWAYS** refuel in a well-ventilated area, away from sparks and open flames.

- **ALWAYS** use extreme caution when working with **flammable** liquids. When refueling, **stop the engine** and allow it to cool. **DO NOT** smoke around or near the machine. Fire or explosion could result from fuel vapors, or if fuel is spilled on a hot engine.

- **NEVER** operate the vibration roller in an explosive atmosphere or near combustible materials. An explosion or fire could result causing severe *bodily harm or even death*.

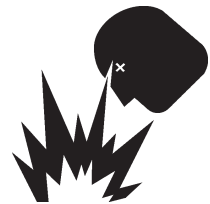

- Topping-off to filler port is dangerous, as it tends to spill fuel.

RULES FOR SAFE OPERATION

- **NEVER** Run engine without air cleaner. Severe engine damage may occur.
- **ALWAYS** read, understand, and follow procedures in Operator's Manual before attempting to operate equipment.
- **ALWAYS** be sure the operator is familiar with proper safety precautions and operations techniques before using pump.
- **ALWAYS** store equipment properly when it is not being used. Equipment should be stored in a clean, dry location out of the reach of children.
- **DO NOT** operate this roller with hydrostatic oil temperature higher than 180 degrees Fahrenheit.
- **NEVER** leave the roller unattended, turn off engine and place lock handle in upright position.
- **CAUTION** must always be observed while servicing this roller. Rotating parts can cause injury if contacted.
- **DO NOT** leave roller with engine running. Use chock blocks if parking roller on a grade.
- **NEVER** ride on a walk-behind roller in unshored trenches or near steep, unsupported banks. The vibration caused by the roller could cause a cave-in.
- **ALWAYS** use extreme care when walking behind the roller, avoid having your feet or clothing getting caught under the dolly wheels or roller.
- Whenever possible try and stand to one side of the roller rather than directly behind it.
- **ALWAYS** use extreme care when operating near obstructions, on slippery surfaces, grades and side slopes.
- **ALWAYS** wear slip resistant safety shoes or boots.
- Unauthorized equipment modifications will void all warranties.
- Uneven grades can cause the handle to **raise** or **lower** unexpectedly, striking the operator by surprise.
- When working on slopes, avoid **sidehill travel** whenever possible. Operate up and down travel only. Remember, the danger of sliding on and/or tripping on steep slopes is always present
- **NEVER** ride on a walk-behind roller unless it is designed to accommodate riders and an appropriate seat is provided.
- Refer to the **Engine Owner's Manual** for engine technical questions or information.
- **High Temperatures** – Always stop engine and allow the engine to cool before adding fuel, oil or performing service and maintenance functions. Contact with *hot* components can cause serious burns.
- **NEVER** engage the "**free wheel engagement lever**" when parked on an incline.
- **NEVER** disconnect any "**emergency or safety devices**". These devices are intended for operator safety. Disconnection of these devices can cause severe injury, bodily harm or even death! Disconnection of any of these devices will void all warranties.

Emergencies

- **ALWAYS** know the location of the nearest **fire extinguisher** and **first aid kit**. Know the location of the nearest telephone. Also know the phone numbers of the nearest **ambulance, doctor** and **fire department**. This information will be invaluable in the case of an emergency.

Maintenance Safety

- **NEVER** lubricate components or attempt service on a running machine.
- **ALWAYS** allow the machine a proper amount of time to cool before servicing.
- Keep the machinery in proper running condition.
- Fix damage to the machine immediately and always replace broken parts.
- Dispose of hazardous waste properly. Examples of potentially hazardous waste are used motor oil, fuel and fuel filters.
- **DO NOT** use food or plastic containers to dispose of hazardous waste.
- **DO NOT** pour waste, oil or fuel directly onto the ground, down a drain or into any water source.

Lifting

- The roller has an operating weight of approximately 1,045 lbs. (474 Kg). Use lifting equipment capable of lifting this weight.
- **ALWAYS** check the roller's transport hooks. Make sure the hooks are secure and tight before lifting the machine.

OPERATION AND SAFETY DECALS

Machine Safety Decals

The V30-4 Compaction Roller is equipped with a number of safety decals. These decals are provided for operator safety and maintenance information. The illustration below and on the next page shows these decals as they appear on the machine. Should any of these decals become unreadable, replacements can be obtained from your dealer.



P/N 511782

ESSICK SAFETY INSTRUCTIONS
A MULTIQUIP COMPANY

1. Do not operate or service this machine before reading the operating and maintenance manual.
2. Keep all inexperienced and/or unauthorized people away from equipment at all times
3. Do not operate this equipment unless all guards and safety devices are attached and in place.
4. Keep this equipment in safe operating at all times.
5. Caution must be exercised while servicing this equipment. Rotating and moving parts can cause injury if contacted.
6. Stop engine and allow to cool before adding fuel or oil.
7. Stop engine when leaving equipment.
8. Block unit when parking on a slope.
9. Unauthorized equipment modifications will void all warranties.

ESSICK CONSTRUCTION PRODUCTS A MULTIQUIP COMPANY CARSON, CALIFORNIA 948501

OFF
V
I
B
R
A
T
I
O
N
ON
512071

F
O
R
W
A
R
D
511766

R
E
V
E
R
S
E
511767

USE COCOA MAT ONLY
WHEN ROLLING ASPHALT

LIFT FROM ROLL
WHEN NOT REQUIRED
948044

 CAUTION
ATTACH SAFETY CHAIN
DURING TRANSPORT
511769

WATER TANK
948438

511768

HYDRAULIC OIL
SHELL TELLUS 32
CHECK LEVEL EVER 50 HOURS

PRE-WET MATS
BEFORE USING
948366

PUSH
TO STOP
9486330

TURN ON
WATER TANK
OUTLET VALVE
948484

NAMEPLATE

CONTACT MULTIQUIP
SERVICE DEPT.



TABLE 1. ENGINE SPECIFICATIONS

	Model	Honda GX340K1QAE	Robin EH34OYS0610	Yanmar L100AEDE/ L100EEDEVK3 (EPA Approved)
Engine	Type	Air-cooled 4 stroke, overhead valve, single cylinder, horizontal shaft gasoline engine	Air-cooled 4 stroke, overhead valve, single cylinder, horizontal shaft gasoline engine	Single cylinder, vertical 4-cycle air-cooled diesel
	Bore X Stroke	3.2 in. X 2.50 in. (88 x 64 mm)	3.31 in. X 2.40 in. (84 x 61 mm)	3.39 in. X 2.76 in. (86 x 70 mm)
	Displacement	20.60 cu. (337 cc)	20.63 cu. (338 cc)	24.78 cu. (406 cc)
	Max Output	11 H.P./3600 R.P.M.	11 H.P./3600 R.P.M.	10 H.P./3600 R.P.M.
	Fuel Tank Capacity	Approx. 1.59 U.S. Gallons (6 liters)	Approx. 1.6 U.S. Gallons (6 liters)	Approx. 1.65 U.S. Gallons (6.1 liters)
	Fuel	Unleaded Automobile Gasoline	Unleaded Automobile Gasoline	Diesel Fuel
	Lube Oil Capacity	1.1 liters (1.16 qt)	1.2 liters (1.27 qt)	1.65 liters (1.74 qt)
	Engine Speed Full Load	2650 rpm ±100	2650 rpm ±100	2650 rpm ±100
	Engine Speed Full Idle	1450 rpm ±100	1450 rpm ±100	1450 rpm ±100
	Air Cleaner	Dual Element	Dual Element	Dual Element
	Engine Lubrication	SAE 10W-30 (Oil Grade) SG or SF (Service Class)	SAE 10W-30 (Oil Grade) SG or SF (Service Class)	SAE 10W-30 (Oil Grade) SG or SF (Service Class)
	Speed Control Method	Centrifugal Fly-weight Type	Centrifugal Fly-weight Type	Centrifugal Fly-weight Type
	Starting Method	Recoil/Electric Start	Recoil/Electric Start	Recoil/Electric Start
	Dimension (LXWXH)	15.0 X 17.7 X 17.4 mm (380 X 450 X 443 mm)	15.83 X 17.91 X 10.09 mm (402 X 455 X 485 mm)	16.42 X 18.50 X 19.45 mm (417 X 470 X 494 mm)
Dry Net Weight	68.4 lbs (31 Kg.) Electric Start	82.8 lbs (33 Kg.) Electric Start 66.1 lbs (30 Kg.) Recoil Start	117 lbs (53 Kg.) Electric Start 106 lbs (48 Kg.) Recoil Start	

TABLE 2. ROLLER SPECIFICATIONS

Impact Force	3,730 lbs. (1,692 kg)
Frequency	4,400 vpm
Gradeability	21 Percent
Drum Width	30 in. (76.2)
Overall Width	35.5 in. (90.1)
Drive System	Hydrostatic
Travel Speed	0-2.5 mph (0-4 kph)
Water Tank Capacity	8.3 gal. (31.4 liters)
Compaction Depth of Dirt	10 in (24.9 cm)
Compaction Depth of Asphalt	4.0 (9.9 cm)
Vibration Amplitude	.019 in.
Operating Weight (Empty)	1,045 lbs. (474 kg.) Honda/Robin
Operating Weight (Empty)	1,065 lbs. (483 kg.) Yanmar

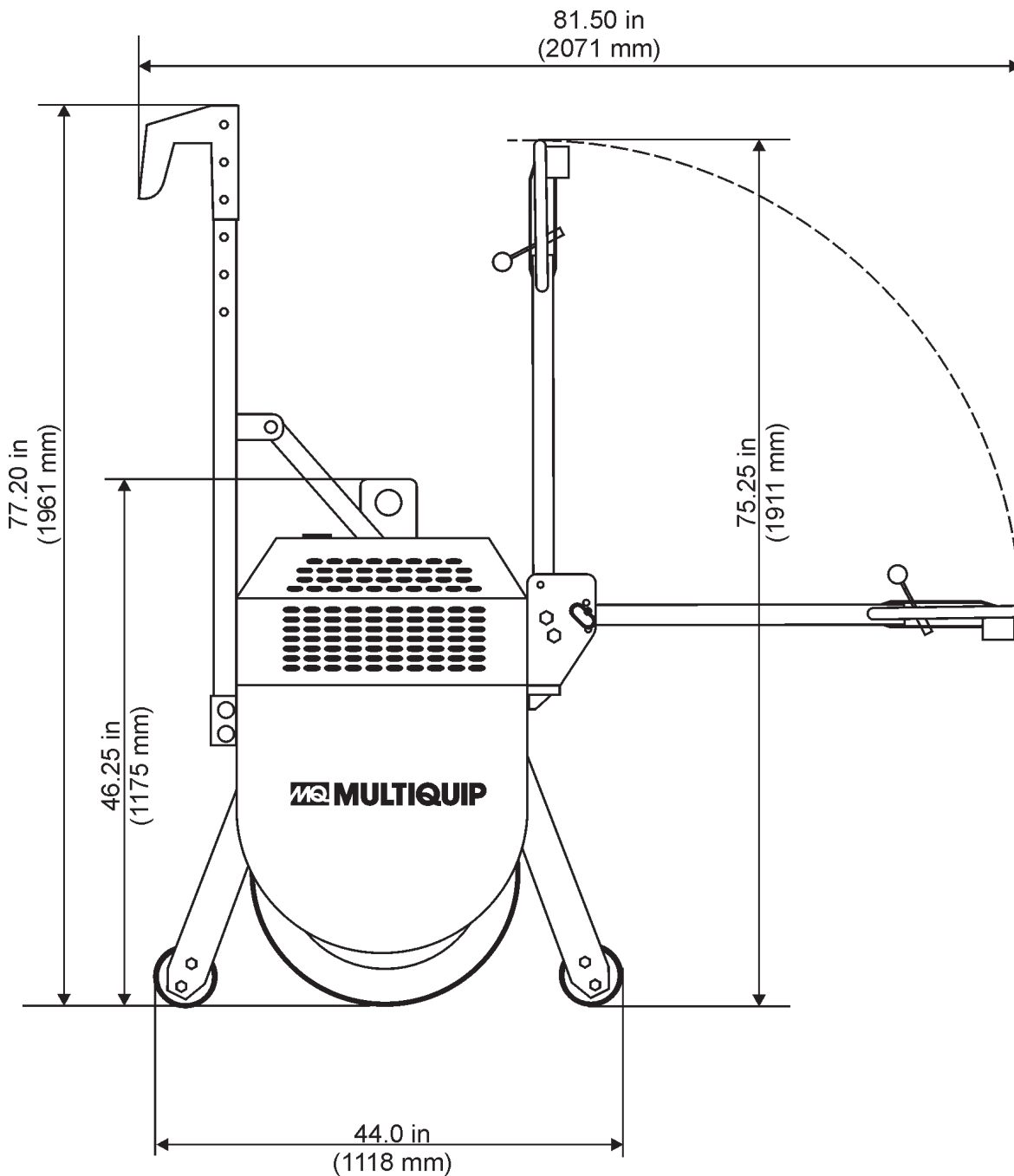

Figure 1. V-30-4 Roller Dimensions Side View)

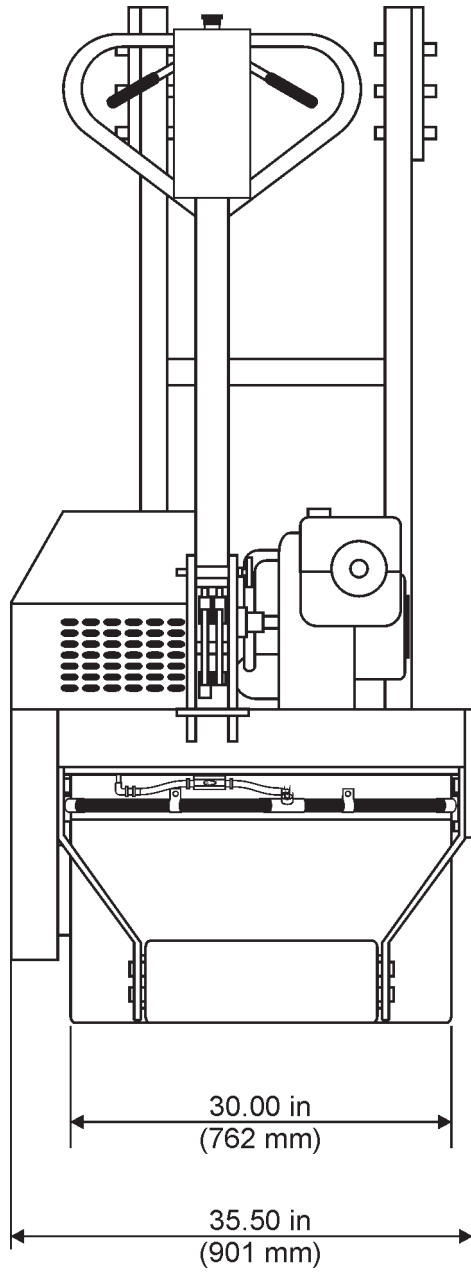

Figure 2. V30-4 Roller Dimensions (Front View)

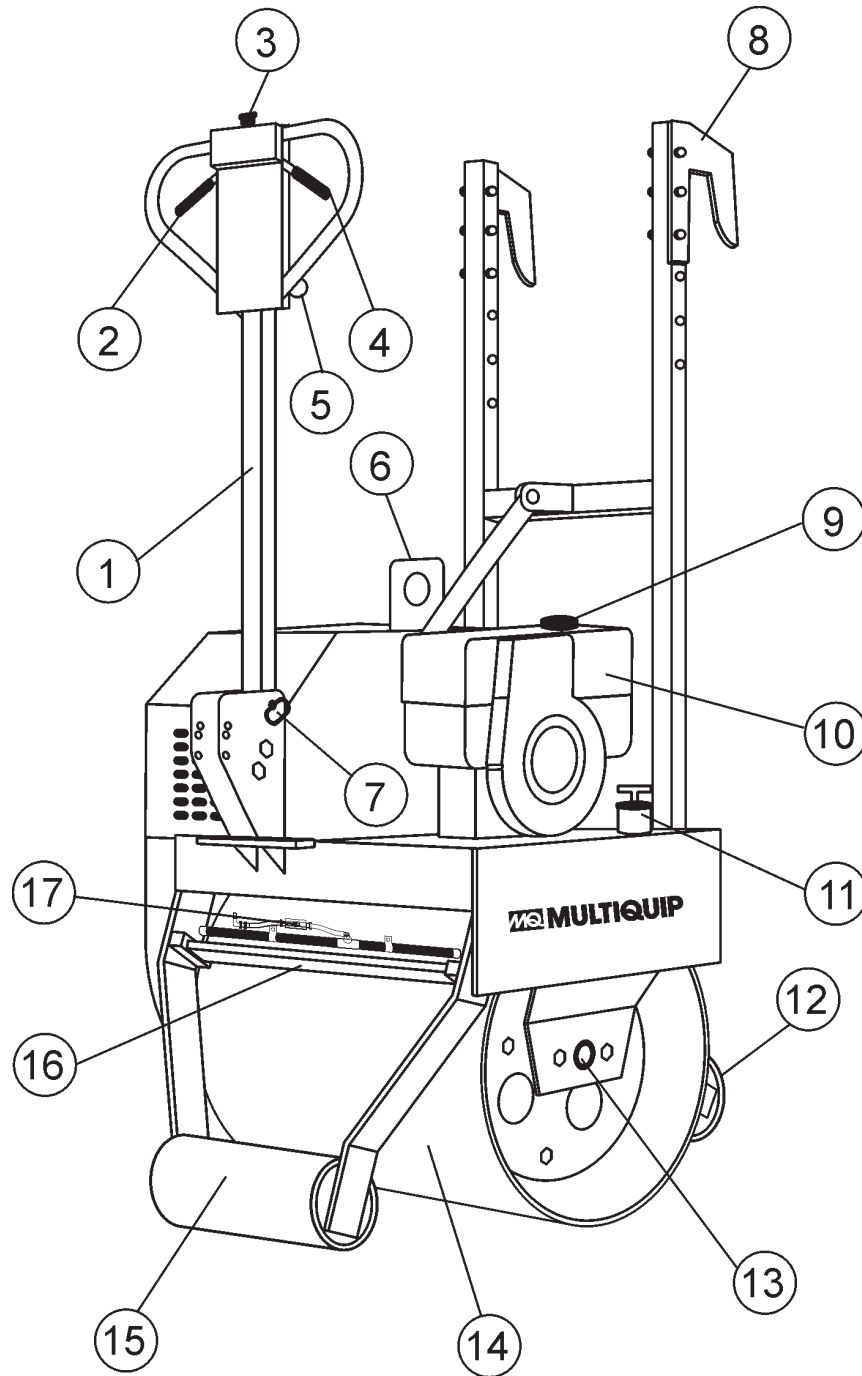

Figure 3. Roller Components 1

Figure 3 shows the location of the components and basic components for the V30-4 compaction roller. The function of each component or control is described below:

1. **Multi-Position Handle Bar** – This bar can be set to four different positions, park, high, middle and low. When transporting the roller, **always** have the handle bar in the upright (stow) position.
2. **Forward Travel Lever** – This is a variable speed control lever. Squeeze this lever to make the roller travel in a forward direction.
3. **Emergency Stop Button** – Press this button to stop the roller in the event of an **emergency**. **DO NOT** use this button as a means of stopping the roller under normal conditions. When starting the engine make sure that this push-button switch is in the up position.
4. **Reverse Travel Lever** – This is a variable speed control lever. Squeeze this lever to make the roller travel in a reverse direction.
5. **Vibration Control Lever** – Move this lever to the **ON** position and the eccentric will produce a vibration frequency of 4,400 vpm (vibrations per minute). Move the lever to the **OFF** position to stop the vibrations.
6. **Lifting Hook Eye** – Attach a crane or lifting device to this lifting hook eye. The lifting device should have a lifting capacity of 1,000 lbs. (450 kg.)
7. **Handle Bar Release Pin** – Remove this pin to position the handle bar to the desired position. Make sure to reinsert release pin and cotter pin after each new position.
8. **Transport Hooks** – These hooks are used in the transportation of the roller (Figure 4). The hooks allow the roller to hang over the tailgate of a dump truck.

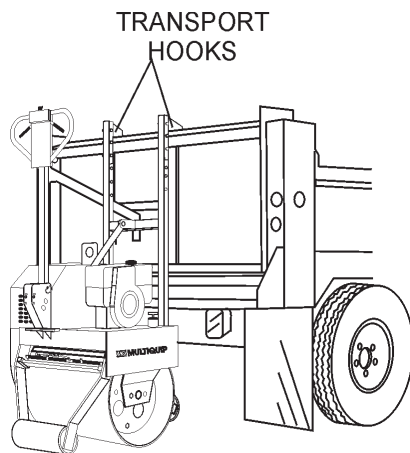

Figure 4. Transport Hooks

9. **Fuel filler Port** – Remove this cap to determine the amount of fuel in the fuel tank. If low, add fuel through this port.
10. **Engine** – This roller uses three different types of engines, Honda GX-340, Robin EH-34 and Yanmar L100 (Diesel). For additional engine information read the engine Owner's Manual supplied with the roller.
11. **Water Tank Filler Port** – Remove this cap to determine the amount of water in the water tank. If low, add **clean** water through this port. This water tank holds 8.3 gallons (31.4 liters) of water.
12. **Rear Stabilizer Roller** – This roller aids the roller in maintaining stability (prevents tipping) and simplifies handling when maneuvering the roller.
13. **Zerk Fittings** – Lube and grease these fittings as recommended in the maintenance section of this manual.
14. **Main Vibratory Roller** – This roller is 30 inches wide **steel drum** with beveled edges. The beveled help prevent asphalt marring.
15. **Front Stabilizer Roller** – This roller aids the roller in maintaining stability (prevents tipping) and simplifies handling when maneuvering the roller.
16. **Coco Mat/Scrapper Blade** – This mat and blade helps prevent the buildup of material between the drum and frame. When using the roller for earth compaction **DO NOT** let the mat come in contact with the roller drum. A hook type latch is provide to keep the mat away from the drum.
17. **Sprinkler System/Water Shut-off Valve** – A gravity feed spray bar is provided for the wetting the roll for asphalt pavement. Turn the water valve to the **open** position to let water flow, return this valve to the **closed** position when water is not required. In addition a water filter has been provided to prevent foreign matter from clogging the spray bar holes. Clean this filter as referenced in the maintenance section of this manual.

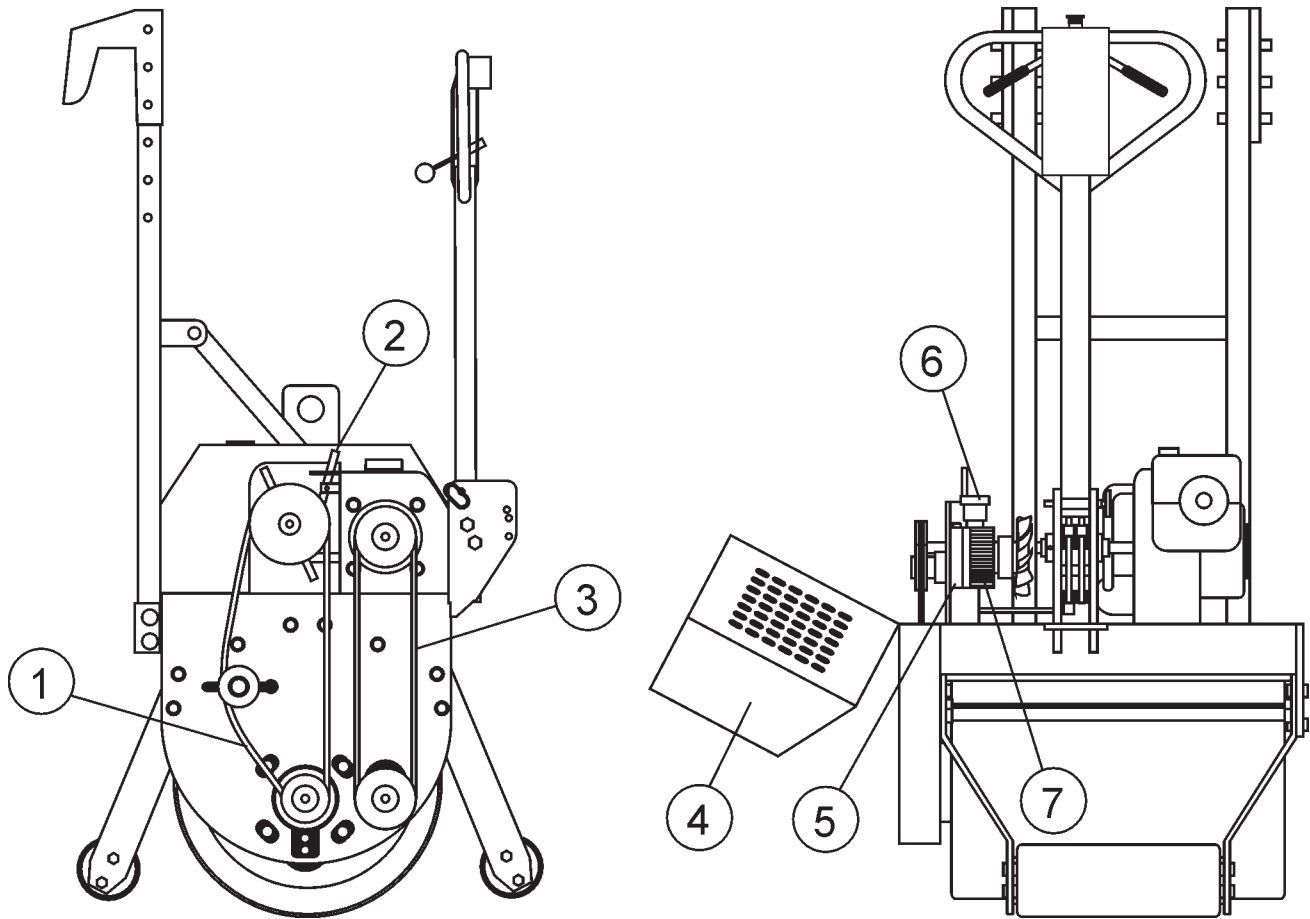

Figure 5. Roller Components 2

Figure 5 shows the location of additional components for the V30-4 compaction roller. The function of each component or control is described below:

1. **Vibration Drive V-Belt** – This belt is required to make the roller vibrate. Check this V-belt as outlined in the maintenance section of this manual.
2. **Free Wheel Engagement Lever** – Under normal conditions this lever should be placed in the **forward** position (engaged). In the event the roller becomes disabled and must be moved (will not start), place the lever in the **side** position (disengaged).

This will allow the roller drum to rotate (free wheel). **IMPORTANT!**, this lever is only to be used in cases where the roller has been disabled. In normal operating conditions this lever should be left in the engaged position (forward)

3. **Travel Drive V-Belt** – This belt is required to make the roller travel in a forward or reverse direction. Check this V-belt as outlined in the maintenance section of this manual.
4. **Compartment Hood** – Remove this hood to gain access to the V-belts, hydrostatic pump, coupling components, free wheel engagement lever etc.
5. **Hydrostatic Pump** – Provides hydraulic pressure to the drive system.
6. **Hydrostatic Fluid Reservoir** – Fill this reservoir with hydrostatic transmission fluid. Fill with Mobil 300, GM Dextron B or Ford MCZ-41A type transmission fluid.
7. **Cogged- Drive Belt** – This belt is used with the hydraulic pump. Check this cogged drive belt as outlined in the maintenance section of this manual.

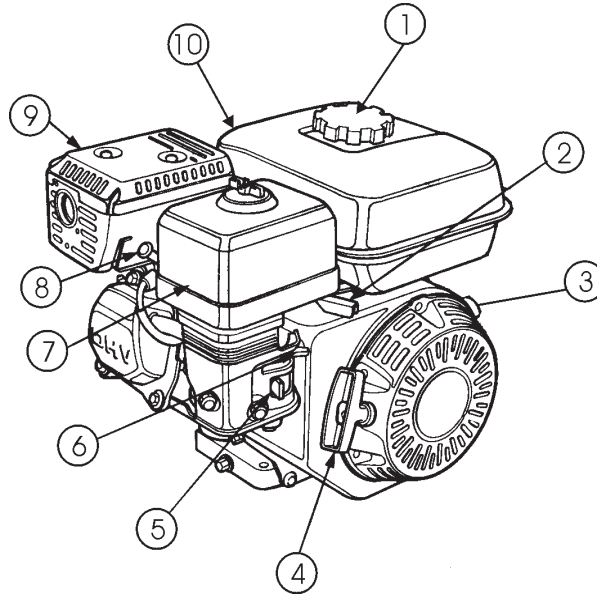

Figure 6. Engine Controls and Components (HONDA)

INITIAL SERVICING

The engine (Figure 6) must be checked for proper lubrication and filled with fuel prior to operation. Refer to the manufacturers Engine manual for instructions & details of operation and servicing.

1. **Fuel Filler Cap** – Remove this cap to add unleaded gasoline to the fuel tank. Make sure cap is tightened securely. **DO NOT** over fill.



WARNING

Adding fuel to the tank should be accomplished only when the engine is stopped and has had an opportunity to cool down. In the event of a fuel spill,

DO NOT attempt to start the engine until the fuel residue has been completely wiped up, and the area surrounding the engine is dry.

2. **Throttle Lever** – Used to adjust engine RPM speed (lever advanced forward **SLOW**, lever back toward operator **FAST**).
3. **Engine ON/OFF Switch** – ON position permits engine starting, OFF position stops engine operations.
4. **Recoil Starter (pull rope)** – Manual-starting method. Pull the starter grip until resistance is felt, then pull briskly and smoothly.

5. **Fuel Valve Lever** – **OPEN** to let fuel flow, **CLOSE** to stop the flow of fuel.
6. **Choke Lever** – Used in the starting of a cold engine, or in cold weather conditions. The choke enriches the fuel mixture.
7. **Air Cleaner** – Prevents dirt and other debris from entering the fuel system. Remove wing-nut on top of air filter cannister to gain access to filter element.

NOTE

Operating the engine without an air filter, with a damaged air filter, or a filter in need of replacement will allow dirt to enter the engine, causing rapid engine wear.

8. **Spark Plug** – Provides spark to the ignition system. Set spark plug gap to 0.6 - 0.7 mm (0.028 - 0.031 inch) Clean spark plug once a week.
9. **Muffler** – Used to reduce noise and emissions.



WARNING

Engine components can generate extreme heat. To prevent burns, **DO NOT** touch these areas while the engine is running or immediately after operating. **NEVER** operate the engine with the muffler removed.

10. **Fuel Tank** – Holds unleaded gasoline. For additional information refer to engine owner's manual.

V30-4 — GENERAL INFORMATION

The V30-4 Vibratory Roller is a walk-behind vibratory roller specifically designed for the compaction and patching of asphalt type surfaces.

The compaction force is delivered by a 30-inch wide steel drum with beveled edges to help prevent asphalt *marring*. A fully enclosed hydrostatic drive system offers a variable speed control as well as smooth acceleration and braking

HYDROSTATIC DRIVE SYSTEM

This hydrostatic design offers a smooth performance, because of a fully integrated hydrostatically actuated drive system, which provides a variable speed control under varying load conditions. Power from the hydraulic drive system is transferred via a drive belt to a gear reducer.

CONTROLS

The forward-reverse control lever (located on the handle) operates the hydrostatic pump which governs the roller speed and direction of travel. The neutral position of this lever will cause the roller to stop. The vibration control when actuated will apply a force of 4,400 vpm (vibrations per minute). This vibratory feature is controlled by an eccentric shaft via an operator controlled mechanical clutch.

FREE WHEEL ENGAGEMENT LEVER

The hydrostatic transmission is equipped with a free wheel engagement lever, which, when actuated, allows the oil to circulate freely within the roller, thereby permitting the roller to be moved without the engine running. This lever is only to be used in the event the roller is disabled.

This lever is located on the that side of the transmission which faces the front of the roller. It is actuated by placing the handle into the side-lock position. To gain access to this lever raise the roller's hood. **DO NOT** raise hood while engine is running, **STOP** engine.

NOTE

In normal operating conditions the roller will not move in a forward or reverse direction unless the free wheel engagement lever is in the engage position (forward).

SPRINKLER SYSTEM

A 8.3 gallon (31.4 liters) water tank with a gravity feed spray bar is provided for wetting the roll for asphaltic pavement rolling.

Before starting an asphalt rolling job, be sure all spray bar holes are clear of dirt or foreign matter and are working. A coco mat is provided to insure an even distribution of water.

DO NOT leave the coco mat in contact with the roll (drum) when the roller is used for earth compaction. A hook is provided to hold the mat away from the roll. The coco mats are intended to prevent the build-up of material between the drum and the frame.

Always use clean fresh water in the water tank. To prevent rust and foreign debris from clogging the spray bar holes, drain and flush water tank and spray bars every 30 days.

TRANSPORTATION

To help transport the roller from job site to job site, adjustable transport hooks have been provided. These transport hooks allow an operator to place the roller on the tailgate of a dump truck without any assistance. The control handle of the V30-4 roller can be folded vertically for ease of transport and storage.

LIFTING THE ROLLER

When lifting of the roller is required (Figure 7), attach a suitable hook or shackle to the *lifting eye* of the roller. Make sure the lifting device is capable of lifting 1,045 lbs (450 kg).

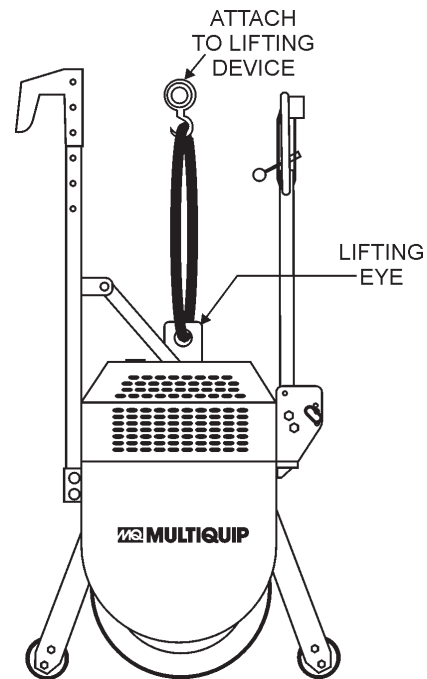

Figure 7. Lifting The Roller

CAUTION :



NEVER! stand under, or get onto the roller while it is being lifted or moved.

CAUTION :



ONLY! use steel ropes or chains that are capable of lifting at least 1,045 lbs (450 kg).

CAUTION :



NEVER! use any other part of the roller for lifting purposes. Use the lifting eye. Using other parts of the roller for lifting will cause severe damage to the roller,

OPERATING ON SLOPES

Special care must be taken when operating the roller on hills or slopes. There exist the possibility of serious injury to the operator and severe damage to the roller in the event of a roll over. **ALWAYS** operate the roller up and down hills rather than from side to side. For safe operation hillside slopes should not exceed 12 degree (21 % grade). See Figure 8 below.

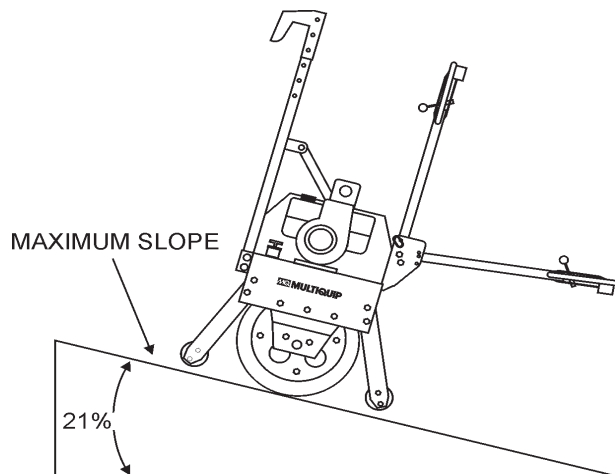

Figure 8. Recommend Slope

Tipping (Rollovers)

NEVER! operate the roller on side slopes (Figure 9). The possibility exist that the roller could tip over (roll over), thus causing bodily harm even death and serious damage to the equipment.

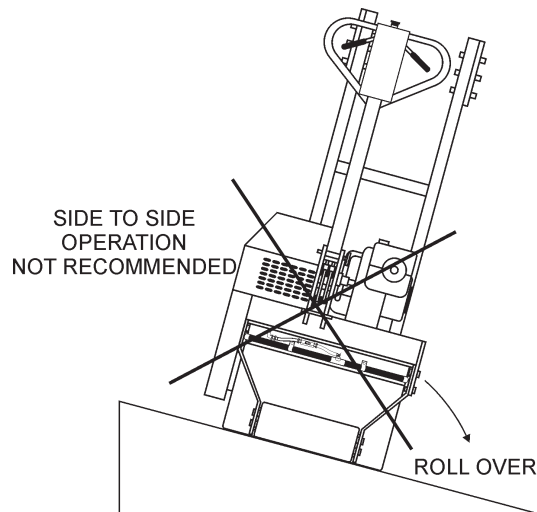

Figure 9. Tipping (Rollover)

In the event the roller does tip over, extreme care must be taken to prevent damage to the engine. When the roller has been tipped over, oil from the engine crankcase can flow into the combustion chamber, which can severely damage the engine the next time it is started.

IMMEDIATELY after a unit has tipped over upright the unit as soon as possible to prevent oil from leaking into the combustion chamber.

CAUTION :



To prevent damage to the engine after a rollover, the unit must **NOT** be started. **NEVER** start a unit after a rollover. **CONTACT** your nearest authorized multiquip dealer for instructions or servicing.

NOTE

NEVER! operate the roller on *side slopes*. The roller may tip over causing injury to personnel and severe damage to the equipment

Before Starting

1. Read safety instructions at the beginning of manual.
2. Clean the ROLLER, removing dirt and dust, particularly the engine cooling air inlet, carburetor and air cleaner.
3. Check the air filter for dirt and dust. If air filter is dirty, replace air filter with a new one as required.
4. Check carburetor for external dirt and dust. Clean with dry compressed air.
5. Check fastening nuts and bolts for tightness.

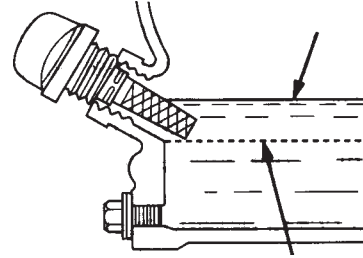

Figure 11. Engine Oil Dipstick (Oil Level)

Engine Oil Check

1. To check the engine oil level, place the saw on secure level ground with the engine stopped, and the diamond blade removed.
2. Remove the filler cap/dipstick from the engine oil filler hole (Figure 10) and wipe it clean.

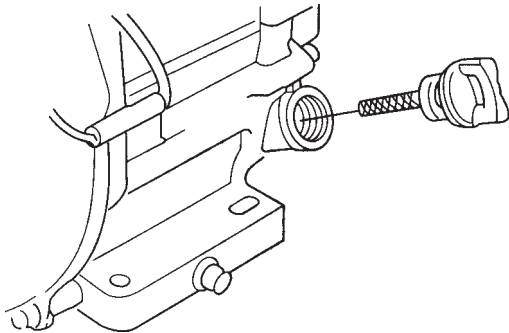

Figure 10. Engine Oil Dipstick (Removal)

3. Insert and remove the dipstick without screwing it into the filler neck. Check the oil level shown on the dipstick.
4. If the oil level is low (Figure 11), fill to the edge of the oil filler hole with the recommended oil type (Table 3). Maximum oil capacity is 400 cc.

NOTE

Reference manufacturer engine manual for specific servicing instructions.

NOTE

Some engines used with the V30-4 Roller have an oil Alert System. This system will automatically stop the in the event of low oil level. **ALWAYS** be sure to check the engine oil level prior to starting the engine.

Table 3. Oil Type

Season	Temperature	Oil Type
Summer	25°C or Higher	SAE 10W-30
Spring/Fall	25°C~10°C	SAE 10W-30/20
Winter	0°C or Lower	SAE 10W-10

Fuel

CAUTION :

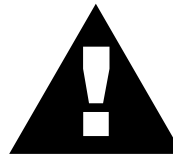

NEVER fill the fuel tank (Figure 12) while the engine is running or in the dark. Fuel spillage on a hot engine can cause a fire or explosion. If fuel spillage occurs, wipe up the spilled fuel completely to prevent fire hazards.

DO NOT smoke while refueling, motor fuels are highly flammable and can be dangerous if mishandled.

Explosive Fuel



Gasoline Check

1. Remove the gasoline cap located on top of fuel tank.
2. Handle Fuel in a safety container. If the container does not have a spout use a funnel.
3. Visually inspect to see if fuel level is low. If fuel is low, replenish with unleaded fuel. When refueling, be sure to use a strainer for filtration. **DO NOT** top-off fuel. Wipe up any spilled fuel.
4. Pay attention to the fuel tank capacity when replenishing fuel. Refer to the fuel tank capacity listed on page 11, Engine Specification Table 1.

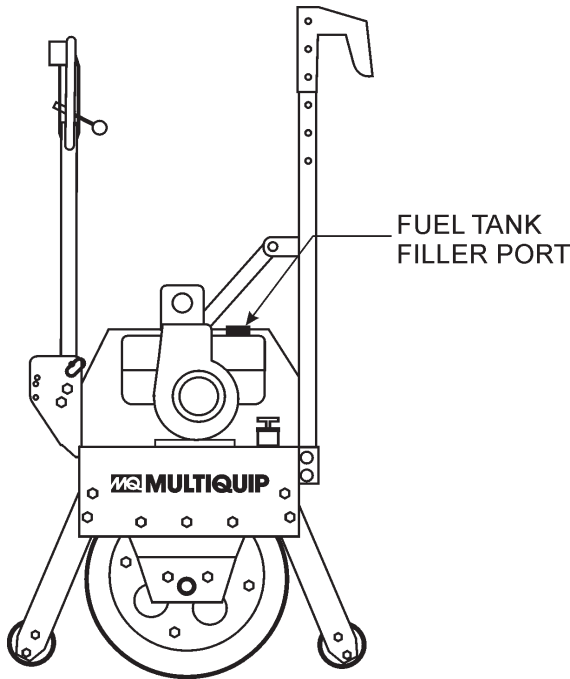

Figure 12. Fuel Tank Filler Port

Water Tank

1. Fill the water tank (Figure 13) with clean water, and verify that valve for the water tank is **closed**.

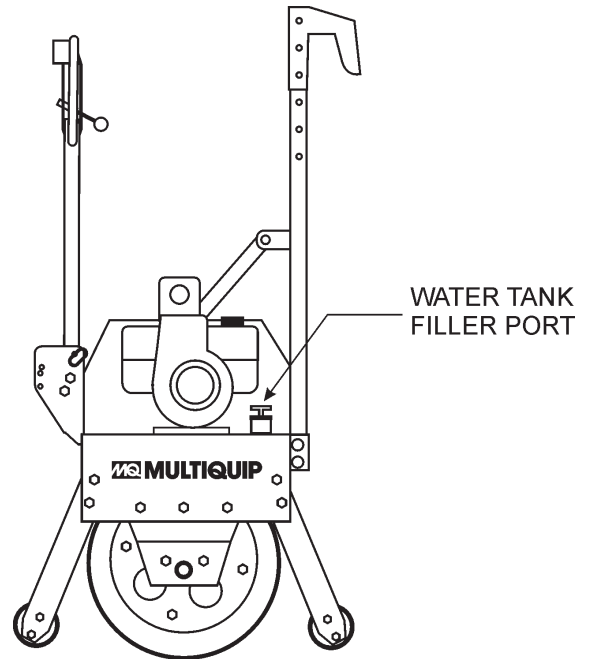

Figure 13. Water Tank Filler Port

Hydraulic Pump Fluid

1. Visually inspect the hydraulic fluid in the hydraulic reservoir (Figure 14). If the hydraulic fluid is low, fill the reservoir with Mobil 300, GM Dextron B or Ford MZC-41A type hydraulic transmission fluid to the correct level. The correct hydraulic fluid level will be indicated on the reservoir.

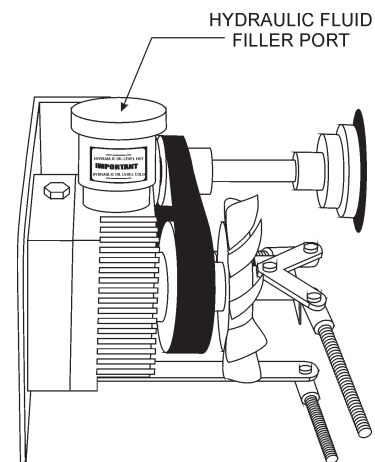

Figure 14. Hydraulic Reservoir Filler Port

Gearbox Lubrication

1. Remove the oil fill drain plug on the gearbox (Figure 15). If the oil level is **correct** oil will begin to leak out. Retighten drain plug.
2. If the level of the oil in the gearbox is **low**, no oil will leak out when the drain plug is removed. Add gearbox oil, type SAE 90 through this drain opening. Fill until oil begins to leak out from the drain opening cavity. If gearbox oil is **low** no oil will leak out when drain plug is removed. Retighten drain plug.

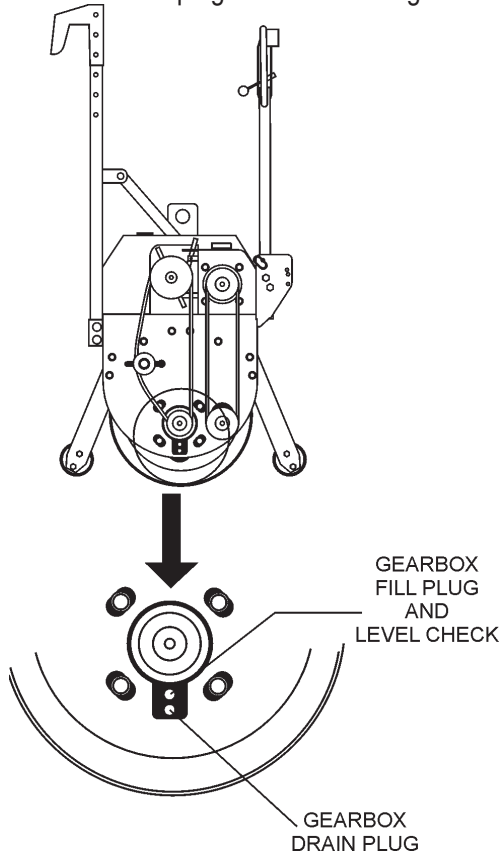

Figure 15. Gearbox Fill and Drain Plug

Vibratory and Travel V-Belt Tension

Check the tension of the vibratory and travel V-belts (Figure 16). This tension can be checked by the amount of deflection when the belt is pressed midway between the two pulleys. The deflection of the travel belt should be approximately 3/4 of an inch (2 cm.), the vibratory V-belt should have a deflection of approximately 2 to 2-1/2 inches (5 to 6 cm.)

Clogged Drive Belt Tension

Check the tension of the clogged V-belt (hydrostatic pump). This tension can be checked by the amount of deflection when the belt is pressed midway between the two pulleys. The deflection of the travel belt should be approximately 1/2 of an inch (1.27 cm.).

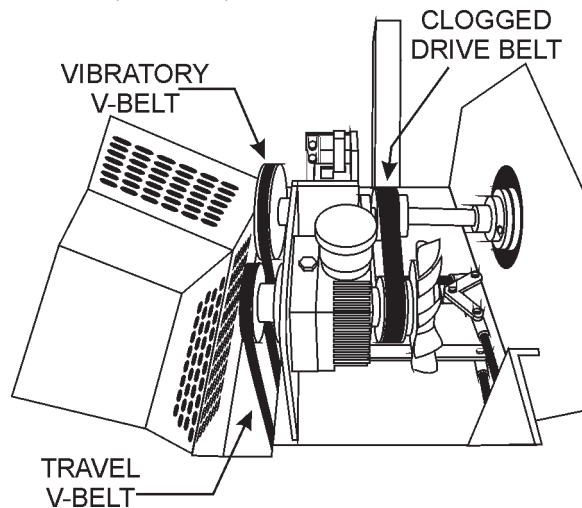

Figure 16. Vibratory, Travel and Pump Belts

Initial Start-up Instructions

Handle Bar Adjustment

Adjustment of the handle bar is made by removing the handle bar **hitch pin**, then pulling the release pin. Once released pin has been removed, position handle bar to desired height (Figures 17 and 18), then insert release pin and lock with cotter pin.

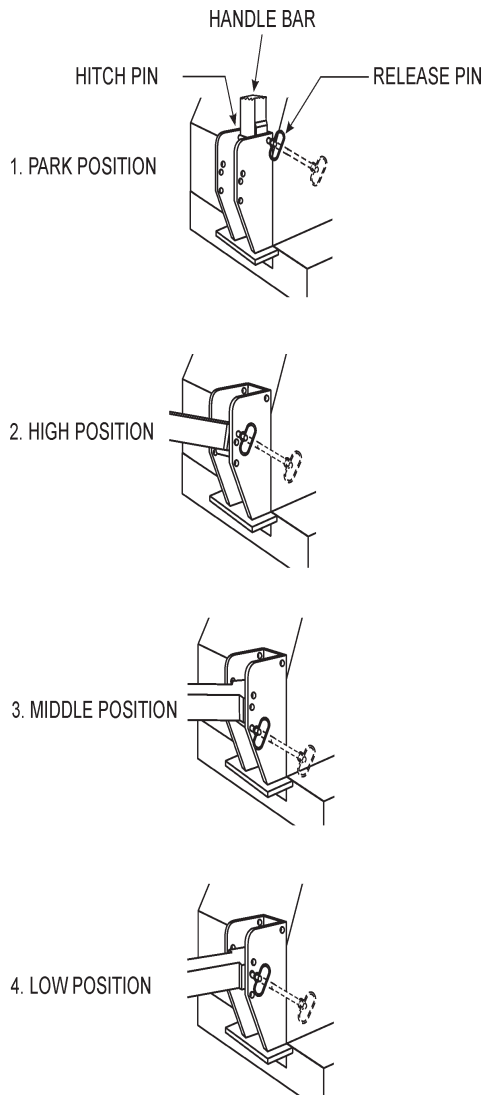

Figure 17. Handle Positions 1

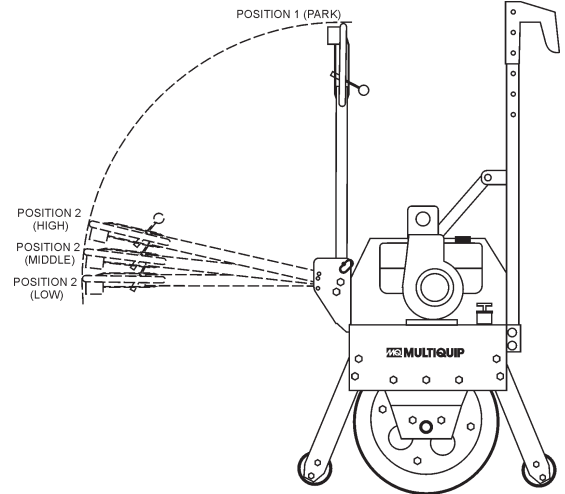
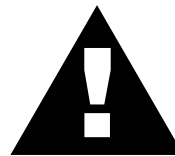

Figure 18. Handle Positions 2

Starting

CAUTION:



DO NOT attempt to operate the roller until the Safety, General Information and Inspection sections have been read and understood. Depending on the type of engine installed on roller, operating steps may vary somewhat. See engine manufacturer's operating manual. The following start-up procedure makes reference to a **HONDA** engine.

1. **ALWAYS** make sure that the emergency stop button (Figure 19) is pulled all the way out (disengage).

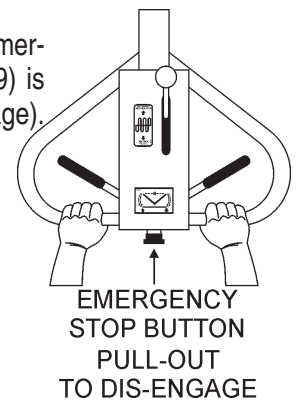

Figure 19. Emergency Stop Button

2. Place the engine **fuel valve lever** (Figure 20) to the "ON" position.

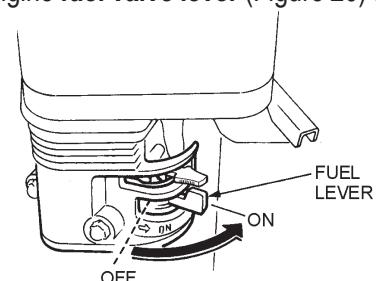

Figure 20. Engine Fuel Valve Lever

- Place the **Engine ON/OFF switch** (Figure 21) in the "ON" position.

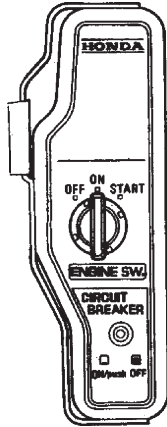

Figure 21. Engine Ignition Switch (On Position)

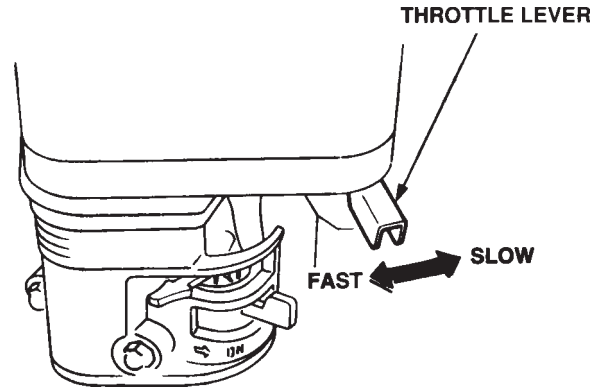

Figure 23. Throttle Lever

- Place the **Engine ON/OFF switch** (Figure 24) to the "START" position. Hold until engine starts.

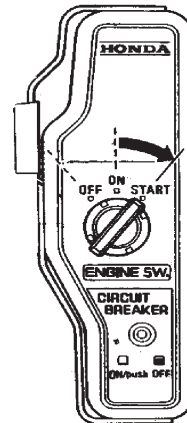

Figure 24. Engine Ignition Switch (Start Position)

NOTE

The **CLOSED** position of the choke lever enriches the fuel mixture for starting a **COLD** engine. The **OPEN** position provides the correct fuel mixture for normal operation after starting, and for restarting a warm engine.

- Place the **Choke Lever** (Figure 22) in the "OPEN" position

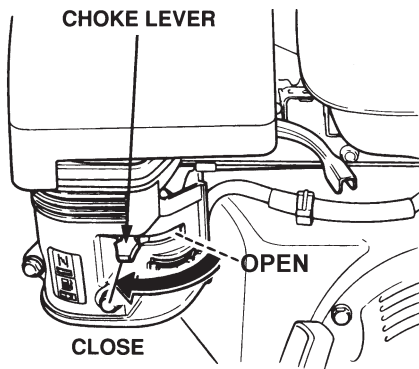

Figure 22. Choke Lever

- Place the **throttle lever** (Figure 23) halfway between **fast** and **slow** for starting. All sawing is done at full throttle. The engine governor speed is factory set to ensure optimum blade operating speeds.

NOTE

DO NOT keep the ignition switch in the **START** position for more than 5 seconds.

- If the engine has started allow switch to return to **ON** position, then slowly return the choke lever (Figure 22) to the **CLOSED** position. If the engine has not started repeat steps 1 through 5.
- Before the roller is placed into operation, run the engine for several minutes. Check for fuel leaks, and noises that would associate with a loose guard and/or covers.
- All rolling is done at full throttle. Your engine governor has been set at the factory to ensure an optimum speed setting.

Operation

CAUTION :



NEVER perform service or maintenance on the roller when the engine is running. The engines used with this roller **DO NOT** require a pre-mix of oil and gasoline.

Free Wheel Engagement Lever

Before the roller can be put into operation, check and make sure that the free *wheel engagement lever* (Figure 25) is in the engagement position (forward). Lift the compartment hood to gain access to this lever.

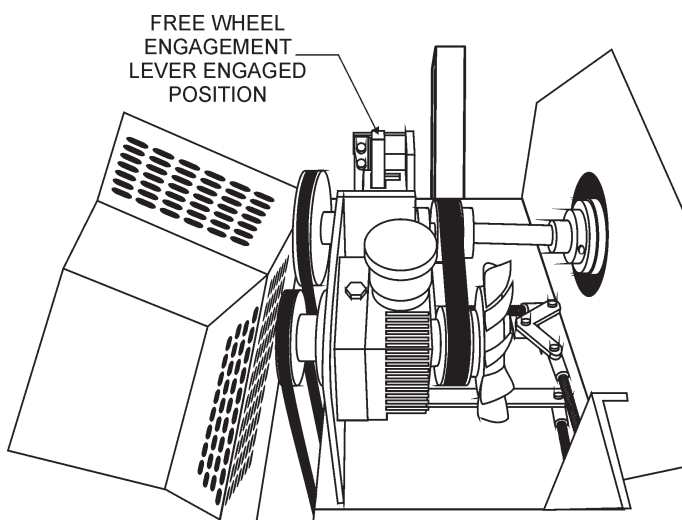

Figure 25. Free Wheel Engagement Lever

Water Shut-off Valve

If the water sprinkler is going to be used for a roll of asphalt paving, fill the water tank with clean water and turn the water valve to the **OPEN** position (Figure 26).

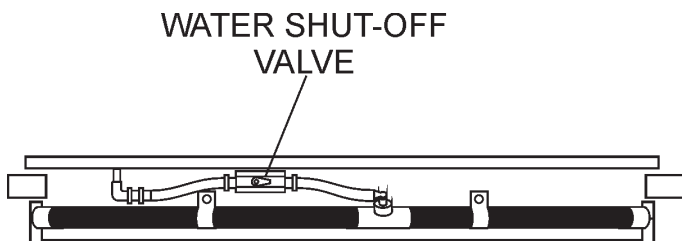

Figure 26. Water Shut-Off Valve

Directional Speed Control Levers

1. With the engine running, both directional and speed control levers (Figure 27) should be in their neutral positions.

NEUTRAL POSITION

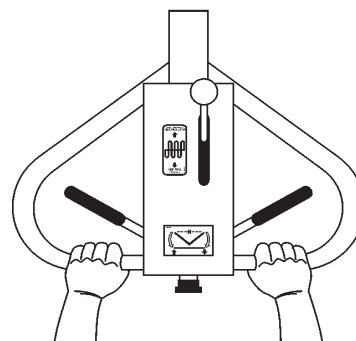

Figure 27. Forward and Reverse Control Levers Neutral Position

1. Squeezing the **left** control lever (Figure 28) will cause the roller to move in a **forward direction**. Squeezing the lever all the way towards the operator will achieve maximum speed. Use a smooth squeezing action on the drive control lever to prevent abrupt takeoffs.

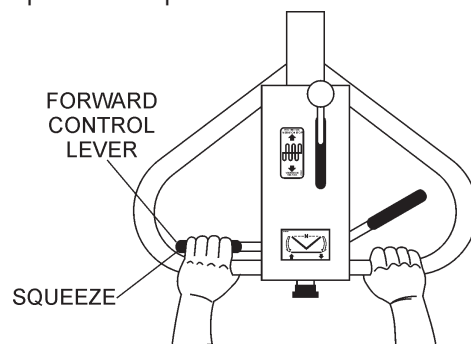

Figure 28. Forward Control Lever

2. Squeezing the **right** control lever (Figure 29) will cause the roller to move in a **reverse direction**. Use a smooth squeezing action on the drive control lever to prevent abrupt take-offs.

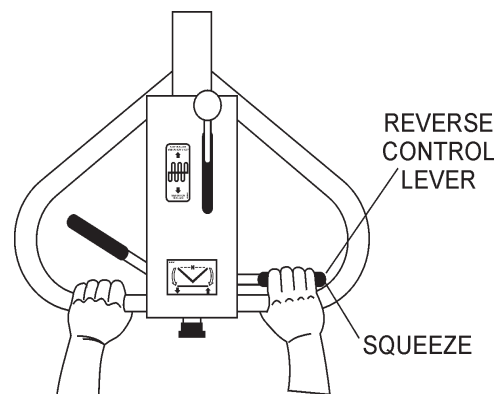

Figure 29. Reverse Control Lever

Vibratory Control

1. For vibratory action, with the engine running (full speed) place the vibratory control lever (Figure 30) to the ON position. The roller will now produce a vibratory frequency of 4,400 vps.

CAUTION :



NEVER! engage vibrator on **concrete** or **asphalt** type surfaces.

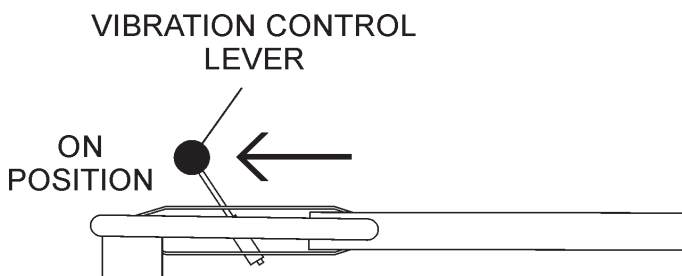

Figure 30. Vibratory Control Lever (ON)

Shut-Down

1. Place the vibration control lever (Figure 31) on the roller to the OFF position (vibration stops).

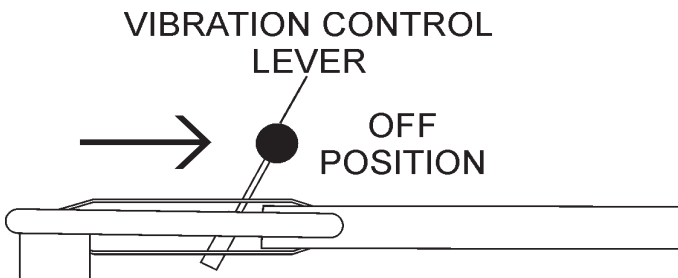

Figure 31. Vibratory Control Lever (OFF)

2. Place the water valve in the **CLOSED** position (if used).
3. Place the **engine throttle lever** (Figure 23) in the **slow** position, and let the engine idle for 3-5 minutes.
4. Place the **Engine ON/OFF switch** (Figure 32) in the "OFF" position and remove the key. Place the key in a safe place.

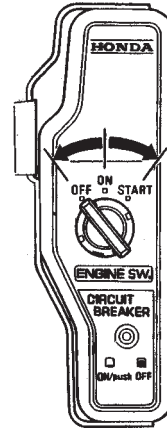

Figure 32. Engine Ignition Switch (OFF Position)

4. Place the engine **fuel valve lever** (Figure 20) in the **OFF** position.
5. Clean the entire roller with warm water and mild soap. Pay close attention to the scrapper bar and spray bar holes, making sure that no dirt or debris is present. Dirt and debris can cause the sprinkler system to get clogged.

Maintenance

Vibrating Shaft Bearings (50 hrs)

The double row of self-aligning ball bearings on the vibrator shaft are special bearings that are not available at the local bearing supply houses. Lubrication of these bearings is very important and should be lubricated after each 50 hours of operation. Rotate roller drum so that grease fittings are towards the lower front.

If it becomes necessary to tear down and reassemble the roller, remove wash out and repack bearing housing with specified grease. After cleaning and checking bearings, they should be lightly packed with the specified grease.

It is essential that no end thrust be applied to these bearings. On reassembly there should be approximately .060" (min) to .120" (max) end float on the vibrator shaft, which may reduce when the shaft reaches working temperature. The bearings must be a light slip fit on the shaft to insure axial freedom.

Hydrostatic Transmission Fluid (50 hrs)

Inspect the fluid level in the hydraulic fluid reservoir every 50 hours of operation, if low, fill with Mobil 300, GM Dextron B or Ford MZC-41A type hydraulic transmission fluid. Change hydraulic transmission fluid on a yearly basis.

Vibrator Clutch Assembly (100 hrs)

The clutch must be greased every 100 hours of operation. Stop the engine with clutch engaged to check V-belt tension. See "ensioning g the V-belts"

Engine and Vibratory Shaft Speed Check (100 hrs)

To check the engine and vibratory shaft speed the use of an "Vibra-Tak" tool will be required.

To check engine speed, place the bottom of the Vibra-Tak tool (knurled cap) on the engine shroud. Move sliding sleeve to a position where the maximum throw of wire reed is obtained. Take a reading from edge of sleeve and multiply reading by 1000. The result is the RPM's the engine is running at.

If the engine RPM speed is too fast or slow, consult the engine owner's manual on how to adjust the engine speed.

To check the vibrations per minute (vpm) of the roller shaft, place the bottom of the Vibra-Tak tool (knurled cap) on the roller drum while the vibrating clutch is engaged. Adjust and read tool as mentioned above. The **vibratory shaft speed** should be 4400 vpm.

Scrapper Blades (Daily)

The scrapper blades should be cleaned daily after each use to prevent the build-up of dirt, mud, tar and any other foreign matter associated with pavement rolling. Use a high pressure water jet (500-1000 psi) and a strong brush to clean the scrapper blades.

V-30-4 Roller (Daily)

Clean the roller daily after each use. If using a pressurized hose keep the pressure between 500 and 1000 psi. Avoid using harsh chemicals, mild detergent soap will do. Avoid direct high water pressure to the engine, hoses and decals.

Water Tank (30 Days)

Drain and flush the water tank and spray bars every 30 days. When refilling the water tank, use only clean water.

Adjusting or Changing Travel V-Belt

1. Un-lock the hood retaining latch and lift the hood to gain access to the V-belts. To adjust the **travel** V-belt, loosen the four mounting screws on the reduction gearbox (Figure 33)

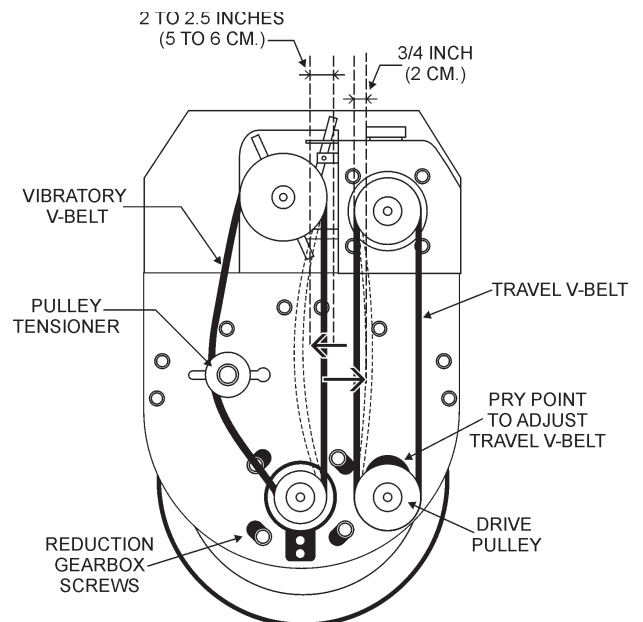

Figure 33. Travel and Vibratory V-Belts

2. Use the prypoint (Figure 33) to achieve correct amount of V-belt tension. Tighten gearbox screws, and check belt tension by verifying the amount of deflection when the belt is pressed midway between the two pulleys. This deflection should be approximately 3/4 of an inch (2 cm.)

Adjusting or Changing Vibratory V-Belt

1. To adjust the vibratory V-belt, loosen the pulley tensioner nut (Figure 33) and adjust the V-belt for approximately 2 to 2-1/2 inches (5 to 6 cm.) of deflection. Check V-belt deflection when V-belt is pressed midway between the two pulleys. When the correct amount V-belt deflection has been achieved, retighten pulley tensioner nut.
2. **IMPORTANT!** always adjust the vibratory V-belt to the recommended belt tension. A tight V-belt will cause the roller to vibrate even if the vibration control lever is in the OFF position. Remember a loose V-belt will decrease the vibratory action or there may not be any vibratory action at all.

Adjusting or Changing Hydrostatic Pump Drive Belt

1. To change or adjust the clogged drive belt (Figure 34) for the hydrostatic pump, loosen the four mounting bolts on the hydrostatic pump. Move the pump unit towards the rear of the roller and adjust the clogged belt for approximately 1/2 inch (1.27 cm) deflection when the belt is pressed midway between the two pulleys. When the correct amount of belt deflection has been achieved, retighten hydrostatic pump mounting screws.

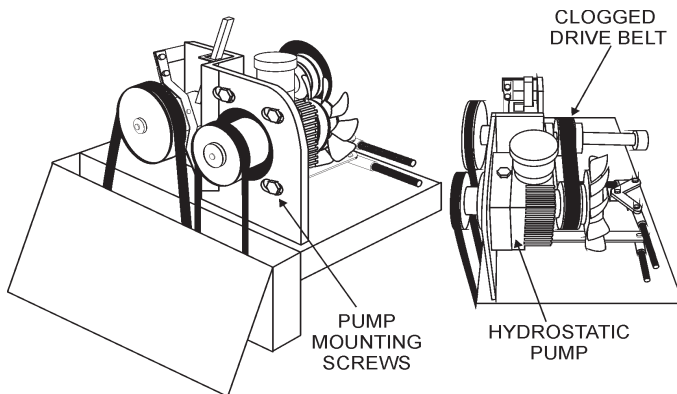

Figure 34. Hydrostatic Pump Drive Belt

NOTE

Use **caution** when adjusting control rods, since engine is running.

Adjusting Control Rods

Travel Control Rod

1. To adjust the travel control rod (controls forward, reverse and neutral) it will be necessary to start the engine and run it at a **low** speed.
2. On the travel control rod, loosen the counter nut on the **rod end**. Remove retaining screw as shown in Figure 35, then rotate the rod end to acquire desired length. Adjust travel rod so that its static position (no force applied on drive control) falls into the neutral position. The roller should not move once adjustment is complete. Retighten all hardware.

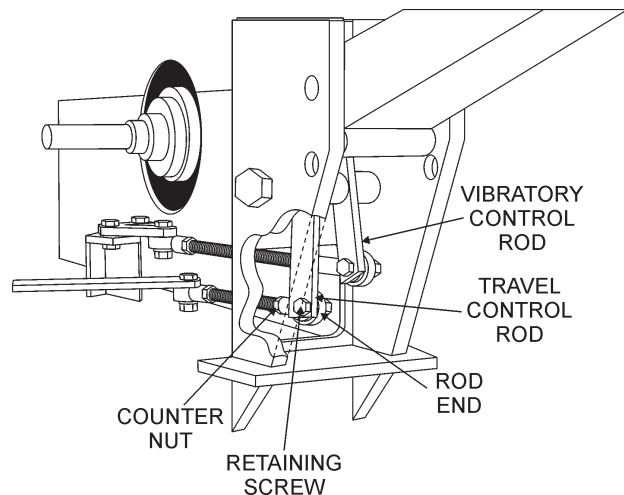

Figure 35. Travel and Vibratory V-Belts

Vibratory Control Rod

1. To adjust the vibratory control rod (controls vibration), loosen the counter nut (Figure 3) on the rod end of the vibratory control rod. Remove the retaining screw on the rod end and rotate the rod to achieve the desired rod length.
2. Continue adjusting, until clutch operation is adequate. The V-belt for the vibratory action should not move when the control lever is in the **OFF** position. Once adjustment is complete, retighten all hardware.

Clutch and Engine coupling Lubrication

Lubricate the clutch and engine coupling as shown in Figure 36.

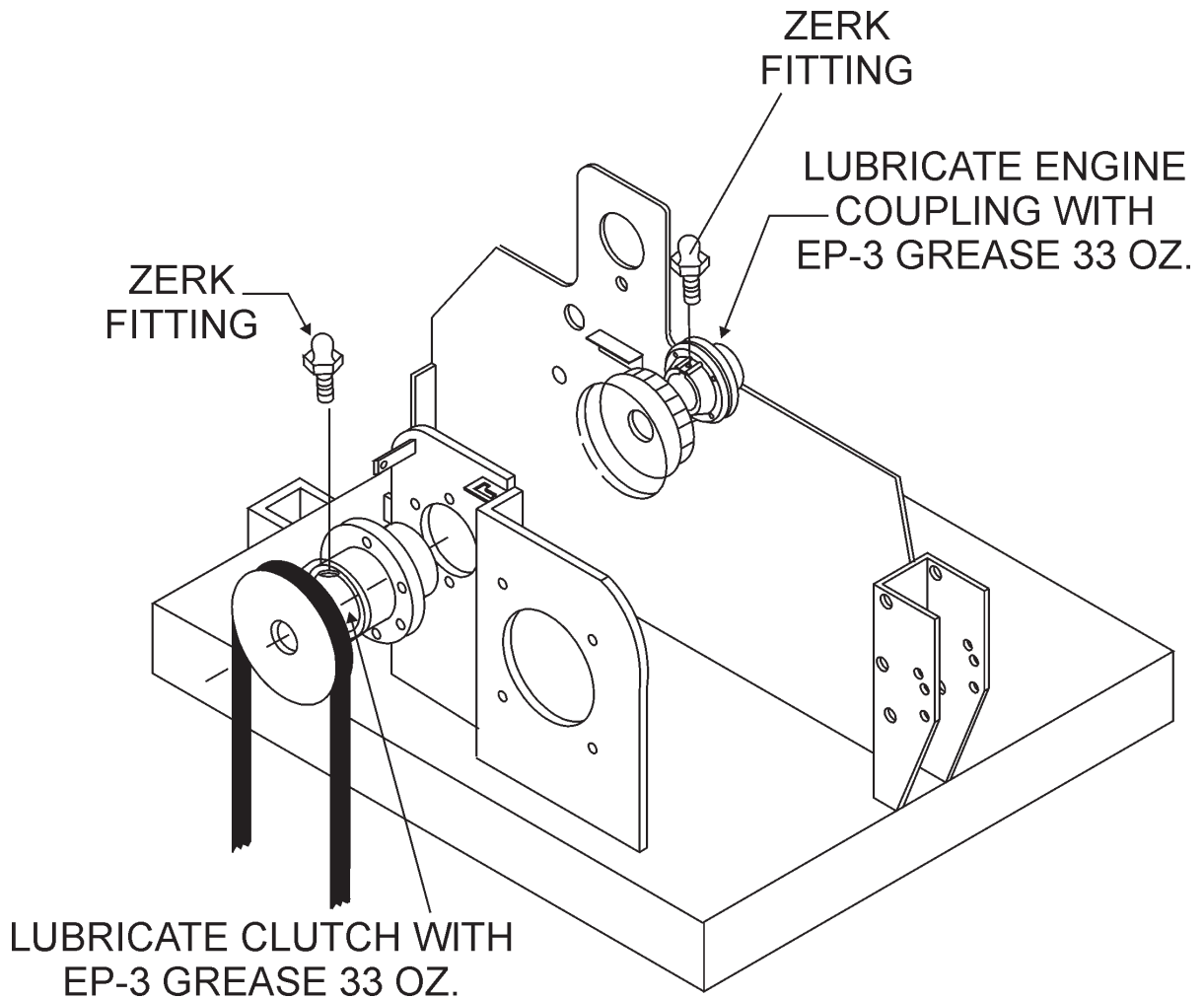

**Figure 36. Clutch and Engine Coupling
Lubrication Points (Zerk Fittings)**

Roller Storage

For storage of the roller for over 30 days, the following is recommended:

- Drain the fuel tank completely.
- Run the engine until the fuel in the injection system is completely consumed.
- Completely drain used oil from the engine crankcase and fill with fresh clean oil, then follow the procedures described in the engine manual for engine storage.
- Drain water tank
- Clean the entire roller and engine compartment.
- Remove battery and store it in cool dry place.
- Place roller control handle in the upright position (vertical).
- Cover the roller and place it a clean dry area, that is protected from harsh elements.
- Remove ignition key, and store in a safe place.

V30-4 — TROUBLESHOOTING (ROLLER)

TABLE 4. ROLLER TROUBLESHOOTING

SYMPTOM	POSSIBLE PROBLEM	SOLUTION
Low Vibration	Low engine RPM?	Adjust to 2650 RPM.
	V-belt slipping?	Adjust tension or replace.
	Clutch rod linkage out of adjustment?	Adjust linkage.
Loss of Power	Low engine speed?	Adjust to 2650, inspect linkage.
	Low transmission oil?	Fill to proper level.
System Operation Hot	Low transmission fluid?	Fill to proper level.
	Check cooling fan?	Replace.
Operates Slow in One Direction	Linkage out of Adjustment?	Adjust linkage.
No Vibration	Defective clutch?	Replace clutch.
	V-belt tension?	Adjust or replace.
Engine Stalls when Vibration Lever is Engaged	Main eccentric bearings?	Inspect vibratory shaft floatation.
	Lubrication problem?	Lubricate bearing.

V30-4 — TROUBLESHOOTING (ENGINE)

TABLE 5. ENGINE TROUBLESHOOTING

SYMPTON	POSSIBLE PROBLEM	SOLUTION
Engine will not start or start is delayed, although engine can be turned over.	Speed control lever is in "STOP" position?	Set speed control lever to "START" position.
	STOP solenoid is in the "STOP" position?	Set stop solenoid to the "START" position. Adjust and lubricate if necessary.
	No Fuel reaching injection pump?	Add fuel. Check entire fuel system.
	Defective fuel pump?	Replace fuel pump.
	Fuel filter clogged?	Replace fuel filter and clean tank.
	Faulty fuel supply line?	Replace or repair fuel line.
	Compression too low?	Check piston, cylinder and valves. Adjust or repair per engine repair manual.
	Fuel injector not working correctly?	Repair or replace injector in accordance with engine repair manual.
	Oil pressure too low?	Check engine oil pressure.
	Low starting temperature limit exceeded	Comply with cold starting instructions and proper oil viscosity.
Defective battery?	Charge or replace battery.	
At low temperatures engine will not start.	Fuel separates has inadequate resistance to low temperatures?	Check whether clear (not turbid) fuel emerges from the fuel line (detach from injection pump). If the fuel is turbid or separated either, warm up the engine or drain the complete fuel supply system. Refuel with winter grade diesel fuel.
	Engine oil too thick?	Refill engine crankcase with correct type of oil for winter environment.
	Defective battery?	Replace battery.
Engine fires but stops soon as starter is switched off.	Throttle lever in STOP position?	Reposition throttle lever to RUN position.
	Fuel filter blocked?	Replace fuel filter.
	Fuel supply blocked?	Check the entire fuel system.
	Electrical problem at fuel solenoid?	Repair using #7 wire.
Engine stops by itself during normal operation.	Fuel tank empty?	Add fuel.
	Fuel filter blocked?	Replace fuel filter.
	Defective fuel pump?	Replace fuel pump.
	Mechanical oil pressure shutdown sensor stops the engine due to low oil?	Add oil. Replace low oil shutdown sensor if necessary.

TABLE 5. ENGINE TROUBLESHOOTING (CONTINUED)

SYMPTON	POSSIBLE PROBLEM	SOLUTION
Low engine power, output and speed.	Fuel tank empty?	Replace fuel filter.
	Fuel filter clogged?	Replace fuel filter.
	Fuel tank venting is inadequate?	Ensure that tank is adequately vented.
	Leaks at pipe unions?	Check threaded pipe unions tape and tighten unions as required.
	Speed control lever does not remain in selected position?	See engine manual for corrective action.
	Engine oil level too full?	Correct engine oil level?
Low engine power output and low speed, black exhaust smoke.	Air filter blocked?	Clean or replace air filter.
	Incorrect valve clearances?	Adjust valves per engine specification.
	Malfunction at injector?	See engine manual.
Air-cooled diesel engine runs very "HOT". Cylinder head overheat, telltale lamp comes on (option)	Too much oil in engine crankcase?	Drain off engine oil down to uppermark on dipstick.
	Entire cooling air system contaminated blocked?	Clean cooling air system, remove shrouds and cooling fin areas.
	Inadequate sealing at air guide plates or capsule elements?	Check that air guide plates and enclosure elements are all present and make a tight seal.

EXPLANATION OF CODE IN REMARKS COLUMN

How to read the marks and remarks used in this parts book.

Items Found In the “Remarks” Column

Serial Numbers-Where indicated, this indicates a serial number range (inclusive) where a particular part is used.

Model Number-Where indicated, this shows that the corresponding part is utilized only with this specific model number or model number variant.

Items Found In the “Items Number” Column

All parts with same symbol in the number column, *, #, +, %, or n, belong to the same assembly or kit.

Note: If more than one of the same reference number is listed, the last one listed indicates newest (or latest) part available.

NOTE

If more than one of the same reference number is listed, the last one listed indicates newest (or latest) part available.

NOTE

The contents of this parts catalog are subject to change without notice.

V30-4 1 TO 3 UNITS WITH HONDA GX340K1QAE,
ROBIN EH-34OYSO610 AND YANMAR L100ADDE
ENGINES.

1 to 3 Units

Qty.	P/N	Description
12	EM906131	BUSHING
12	EM906132	WASHER
3	EM505284	COCOA MAT
3	EM491116	V-BELT TRAVEL
3	EM504233	V-BELT VIBRATORY
3	EM491132	COGGED DRIVE BELT (PUMP)
15	EM504441	MOUNT, SHOCK
3	491010	RUBBER LATCH
3	9807955846	SPARK PLUG (HONDA)
3	17210ZE3505	ELEMENT AIR CLEANER (HONDA)
1	EM502133	CLUTCH ASSY.
1	EM106395	WATER TANK EXPANSION PLUG

NAME PLATE AND DECALS

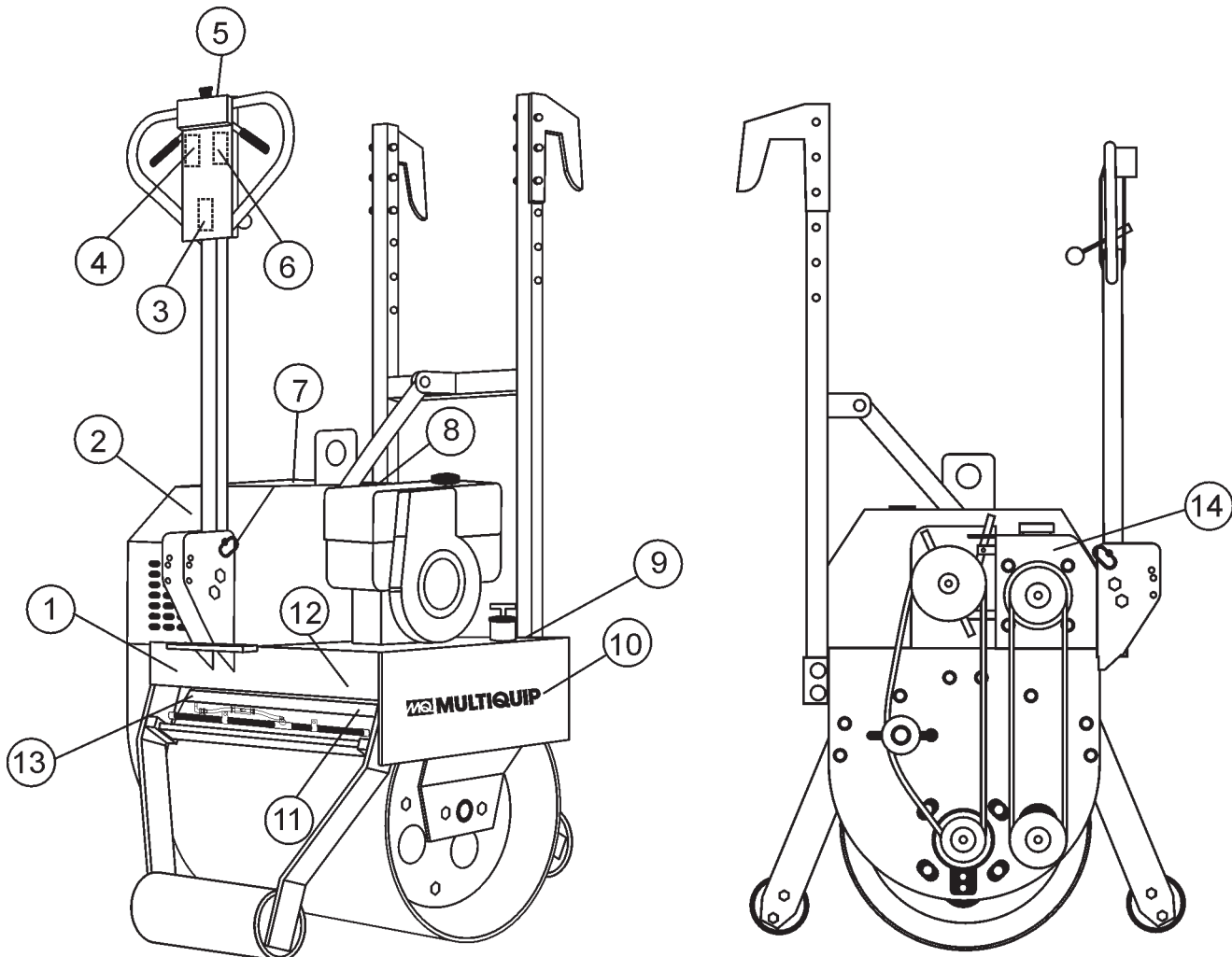

V30-4 — NAME PLATE AND DECALS

NAME PLATE AND DECALS

<u>NO</u>	<u>PART NO</u>	<u>PART NAME</u>	<u>QTY.</u>	<u>REMARKS</u>
1*	EM948484	DECAL : WATER VALVE	1	
2*	EM948501	DECAL : SAFETY INSTRUCTIONS	1	
3*	EM512071	DECAL : VIBRATION ON/OFF	1	
4*	EM511767	DECAL : REVERSE	1	
5*	EM9486330	DECAL : PUSH TO STOP	1	
6*	EM511766	DECAL : FORWARD	1	
7*	EM511769	DECAL : SAFETY CHAIN	1	
8		DECAL : NAME PLATE	1 CONTACT MQ SERVICE DEPT. W/MODEL & S/N
9*	EM948438	DECAL : WATER TANK	1	
10*	EM511782	DECAL : MQ LONG	1	
11*	EM948044	DECAL: COCO MAT	1	
12*	13118	DECAL: POWDER COATED	1	
13*	EM948366	DECAL: PRE-WET MATS	1	
14*	EM511768	DECAL: HYDRAULIC OIL	1	
15	DCLV304	KIT, DECAL	1 INCLUDES ITEMS/*

SEE DECAL ILLUSTRATIONS ON PAGE 10

V30-4 — COCOA MAT ASSY.

COCOA MAT ASSY.

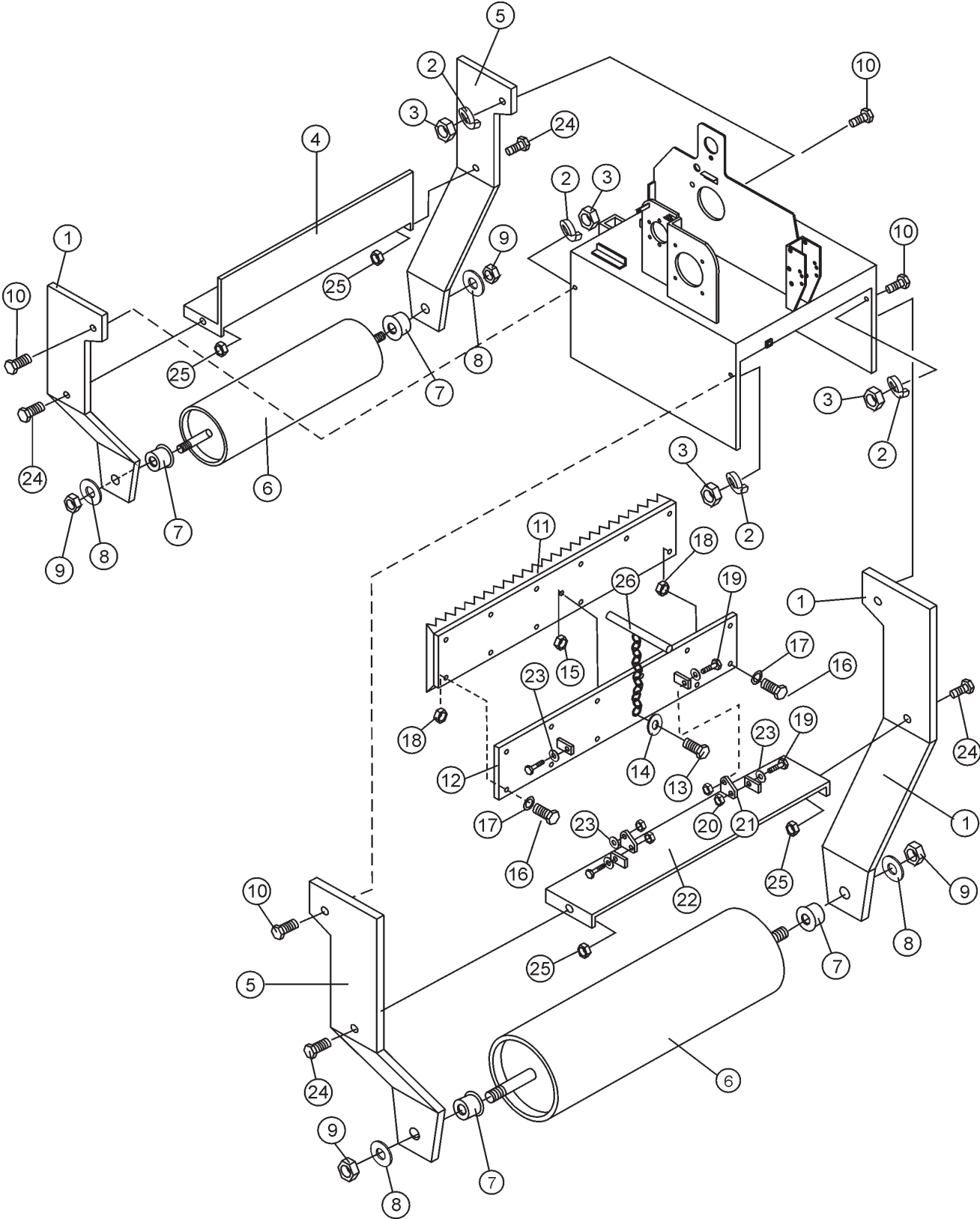

COCOA MAT ASSY.

<u>NO</u>	<u>PART NO</u>	<u>PART NAME</u>	<u>QTY.</u>	<u>REMARKS</u>
1	EM505543	ARM, RH STABILIZER ROLLER	2	
2	EM923348	WASHER, LOCK 5/8	4	
3	EM969023	NUT, 5/8 - 11	4	
4	EM505146	PLATE, FRONT SCRAPER	1	
5	EM505542	ARM, LH STABILIZER ROLLER	2	
6	EM505454	ROLLER, STABILIZER	2	
7	EM906132	BUSHING, ROLLER	4	
8	EM906131	WASHER, BUSHING	4	
9	EM969023	NUT, NYLOC 5/8 - 11	4	
10	EM503982	SCREW, HHC 5/8 - 11 X 2	4	
11	EM505284	MAT, COCOA	1	
12	EM505138	FRAME, COCOA MAT	1	
13	EM492358	SCREW, HHC 1/4 - 20 X 1-1/4	1	
14	EM923057	WASHER, FLAT 1/4	1	
15	EM969049	NUT, NYLOC 1/4 - 20	1	
16	EM963003	SCREW, HHC 1/4 - 20 X 3/4	12	
17	EM923057	WASHER, FLAT 1/4	12	
18	EM969005	NUT, NYLOC 1/4 - 20	12	
19	EM963610	SCREW, HHC 3/8 - 16 X 1	4	
20	EM969013	NUT, NYLOC 3/8 - 16	4	
21	EM505140	BRACKET	2	
22	EM505582	PLATE, REAR SCRAPER	1	
23	3019092	WASHER, FLAT 3/8	4	
24	EM963692	SCREW, HHC 1/2 - 13 X 1-1/2	4	
25	492584	NUT, NYLOC 1/2 - 13	4	
26	EM505375	CHAIN, COCOA MAT	1	

V30-4 — TRAVEL LINKAGE ASSY.

TRAVEL LINKAGE ASSY.

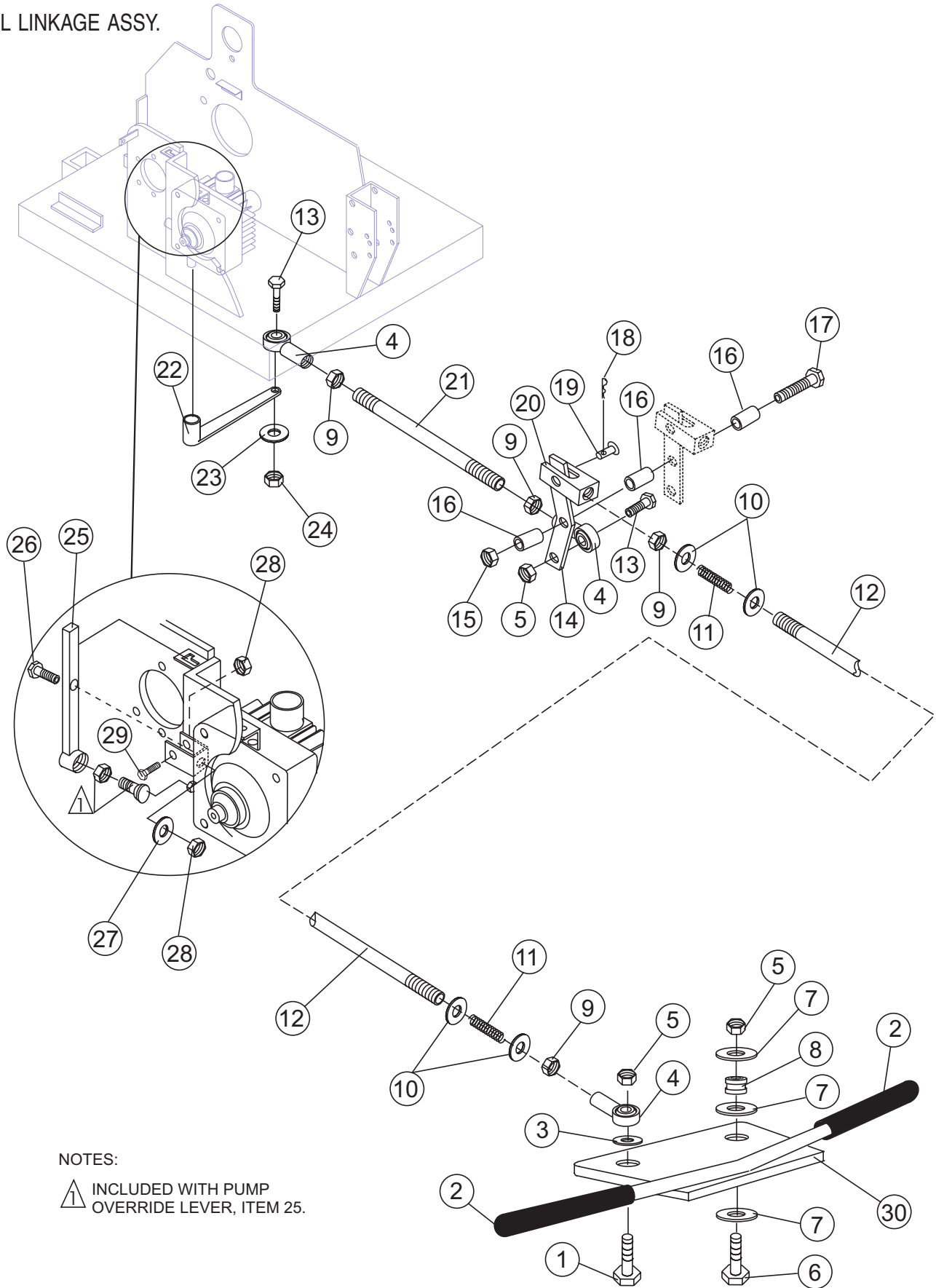

NOTES:

- 1 INCLUDED WITH PUMP
OVERRIDE LEVER, ITEM 25.

V30-4 — TRAVEL LINKAGE ASSY.

TRAVEL LINKAGE ASSY.

<u>NO</u>	<u>PART NO</u>	<u>PART NAME</u>	<u>QTY.</u>	<u>REMARKS</u>
1	EM963057	SCREW, HHC 3/8 - 16 X 1-1/2	1	
2	504564	GRIP, HANDLE	2	
3	503736	SPACER	1	
4	EM959080	ROD END, 3/8 - 24 - R/HAND	3	
5	EM969013	NUT, NYLOC 3/8 - 16	2	
6	492378	SCREW, HHC 3/8 - 16 X 1-3/4	1	
7	503736	SPACER	3	
8	EM503738	BEARING	1	
9	EM490172	NUT, HEX 3/8 - 24	4	
10	3019092	WASHER, FLAT 3/8	2	
11	EM503744	SPRING, LOWER DRIVE CONTROL	2	
12	EM511911	ROD, DRIVE CONTROL	1	
13	963610	SCREW, HHC 3/8 - 16 X 1-1/4	2	
14	EM511883	BELL CRANK, DRIVE CONTROL	1	
15	492584	NUT, NYLOC 1/2 - 13	1	
16	EM511869	BUSHING, OUTER BELL CRANK	3	
17	503111	SCREW, HHC 1/2 - 13 X 4-1/2	1	
18	EM509157	KEY, COTTER 1/16 X 1/2	1	
19	EM511898	PIN, CLEVIS	1	
20	EM511875	CLEVIS, DRIVE CONTROL	1	
21	EM511913	ROD, HYD. PUMP CONTROL	1	
22	EM511909	LEVER, PUMP CONTROL	1	
23	0166 A	WASHER, LOCK 3/8	1	
24	EM969012	NUT	1	
25	EM511890	LEVER, PUMP OVERRIDE	1	
26	EM492365	SCREW, HHC 5/16 - 18 - 1	1	
27	EM923023	WASHER, FLAT 5/16"	1	
28	492582	NUT, NYLOC 5/16-18	2	
29	EM492365	SCREW, HHC 5/16 - 18 X 1-1/4	1	
30	EM511905	HANDLE CONTROL	1	

V30-4 — VIBRATORY LINKAGE ASSY.

VIBRATORY LINKAGE ASSY.

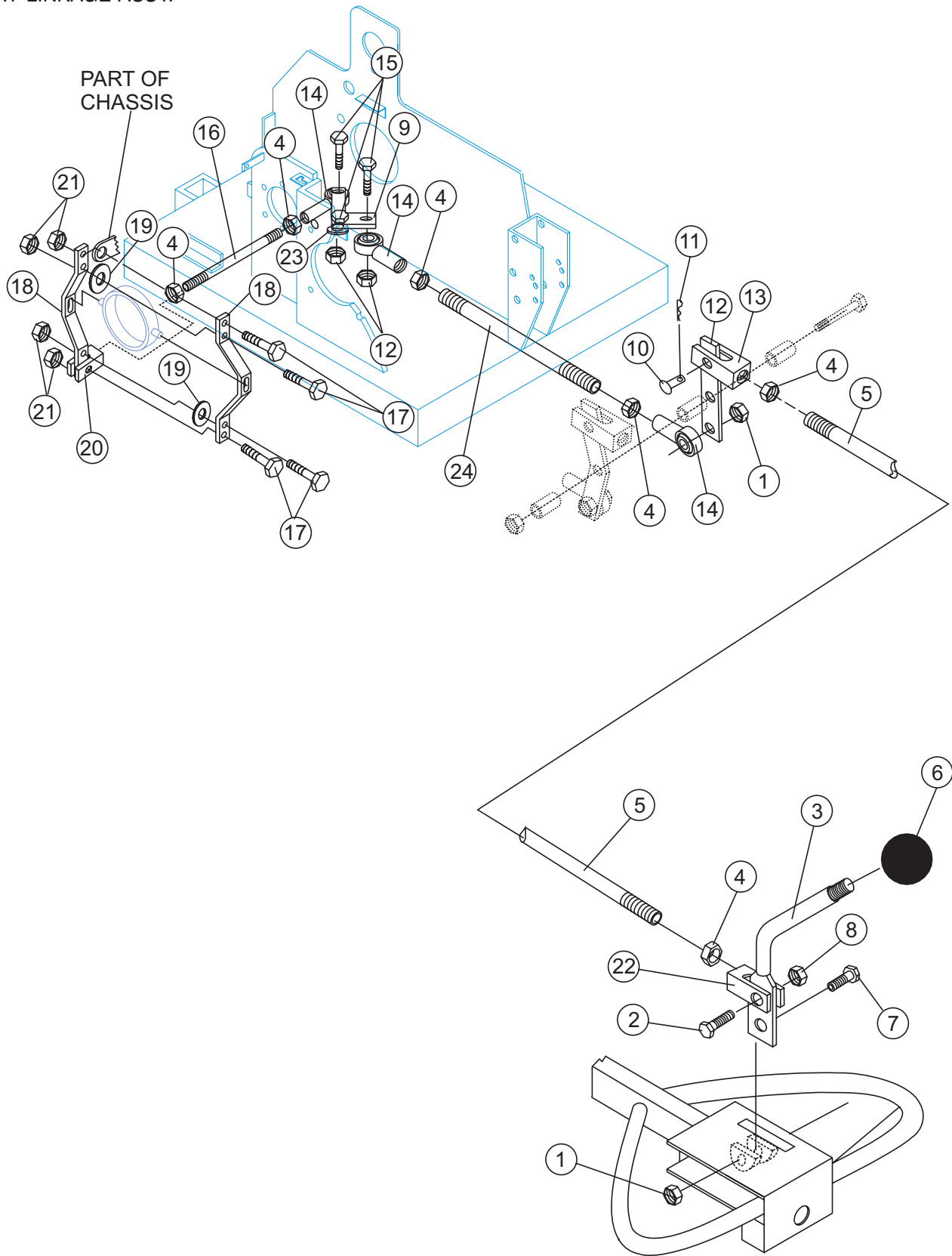

V30-4 — VIBRATORY LINKAGE ASSY.

VIBRATORY LINKAGE ASSY.

<u>NO</u>	<u>PART NO</u>	<u>PART NAME</u>	<u>QTY.</u>	<u>REMARKS</u>
1	EM969013	NUT, NYLOC 3/8 - 16	2	
2	EM492358	SCREW, HHC 1/4 - 20 X 1-1/4	1	
3	EM505279	LEVER, VIBRATORY CONTROL	1	
4	EM490172	NUT, HEX 3/8 - 24	4	
5	EM511912	ROD VIBRATORY CONTROL	1	
6	491019	KNOB	1	
7	EM963059	SCREW, HHC 3/8 - 16 X 2	1	
8	EM969079	NUT, NYLOC 1/4- 20	1	
9	EM511886	BELL CRANK, CLUTCH	1	
10	EM511898	PIN, CLEVIS	1	
11	EM509157	KEY, COTTER 1/16 X 1/2	1	
12	EM511884	BELL CRANK, CLUTCH CONTROL	1	
13	EM511875	CLEVIS, LOWER VIBRATORY CONTROL	1	
14	EM959080	ROD-END, 3/8 - 24 R/HAND	2	
15	EM963610	SCREW, HHC 3/8 - 16 X 1-1/4"	3	
16	EM511914	ROD, NO.1 CLUTCH	1	
17	492364	SCREW, HHC 5/16 - 18 X 1"	4	
18	EM502643	FORK, CLUTCH	2	
19	EM923023	WASHER, FLAT 5/16"	3	
20	EM512067	CLEVIS, CLUTCH	1	
21	442582	NUT, NYLOC 5/16 - 18	1	
22	EM511874	CLEVIS, UPPER VIBRATORY CONTROL	1	
23	3019092	WASHER, FLAT 3/8"	1	
24	EM511915	ROD, NO. 2 CLUTCH	1	

HANDLE ASSY.

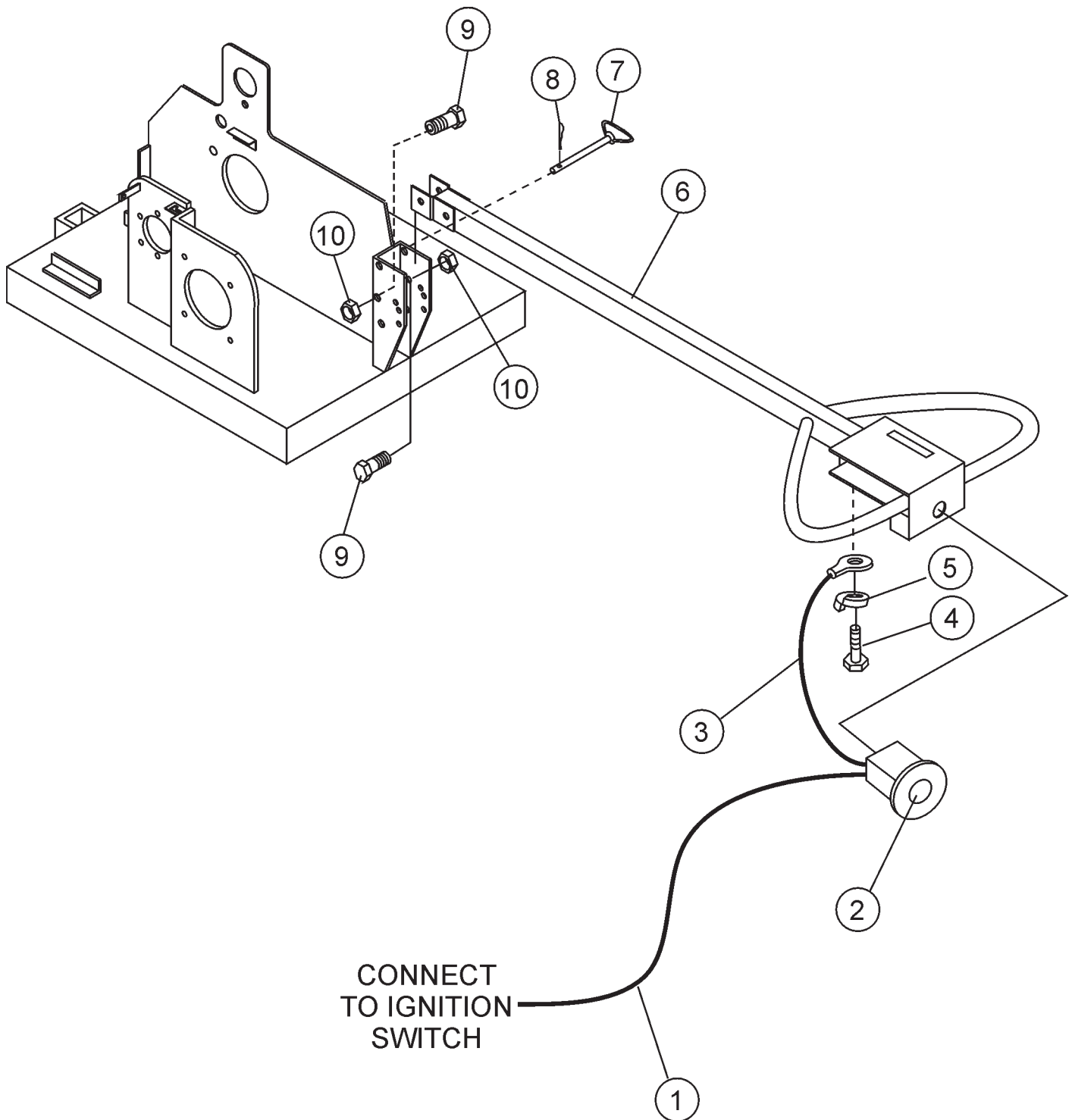

HANDLE ASSY.

<u>NO</u>	<u>PART NO</u>	<u>PART NAME</u>	<u>QTY.</u>	<u>REMARKS</u>
1	EM505307	CABLE ASSY. (ENGINE)	1	
2	EM505398	SWITCH, KILL	1	
3	EM505310	CABLE ASSY. (KILL SWITCH)	1	
4	EM503115	SCREW	1	
5	3103160	WASHER, LOCK 3/16"	1	
6	EM511907	HANDLE BAR	1	
7	EM744	CLEVIS PIN 1/2" X 4"	1	
8	EM745	HAIR PIN 5/8" X 3/4"	1	
9	EM963102	SCREW, HHC 1/2 - 13 X 1-1/4	2	
10	492584	NUT, NYLOC 1/2 - 13	2	

V30-4 — CHASSIS ASSY.

CHASSIS ASSY.

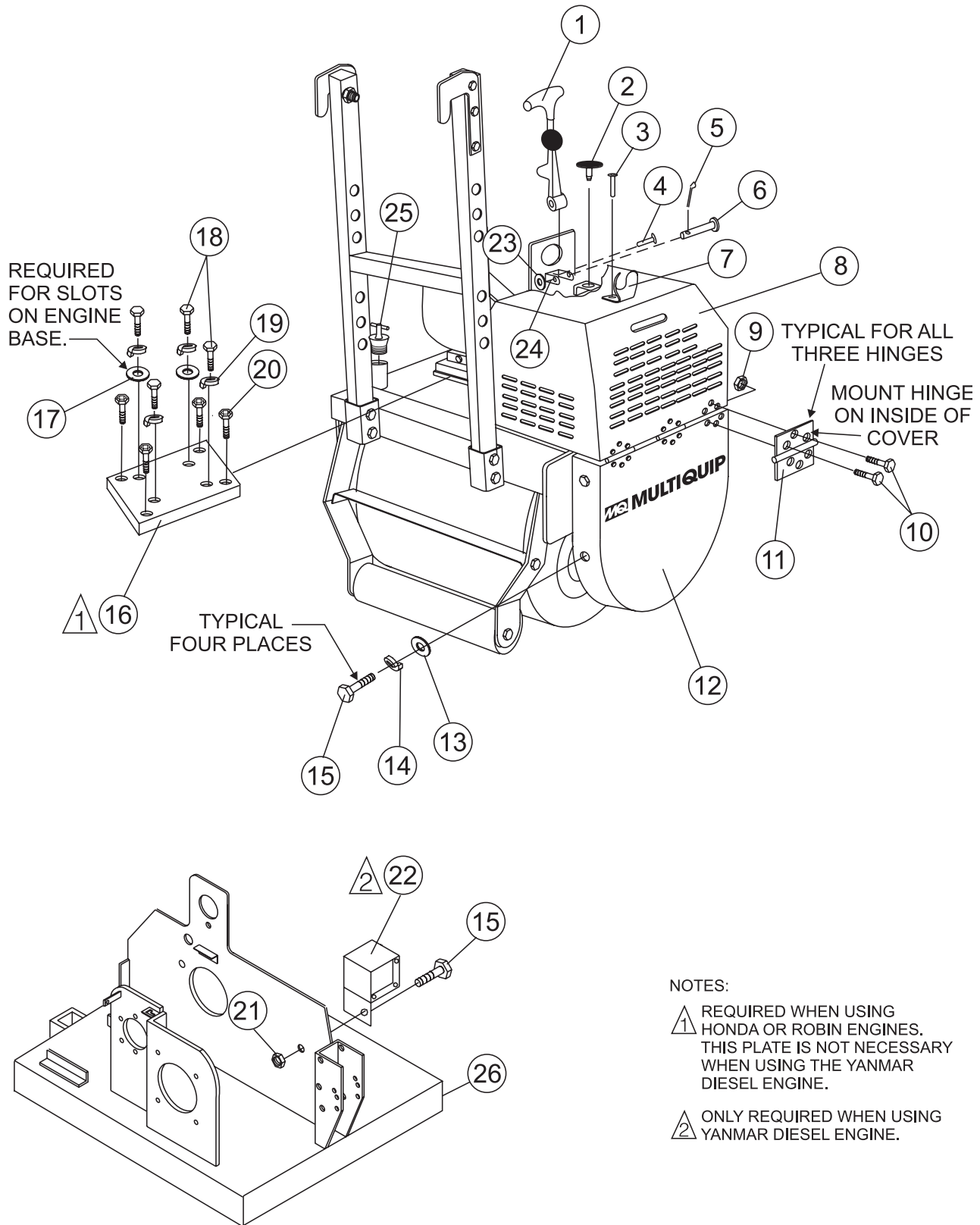

CHASSIS ASSY.

<u>NO</u>	<u>PART NO</u>	<u>PART NAME</u>	<u>QTY.</u>	<u>REMARKS</u>
1	491010	LATCH KIT, ENG HSG (RUBBER)	1	INCLUDES ITEMS W/*
2	490202	RUBBER PROTECTOR	1	
3	503723	RIVET	2	
4	EM503978	RIVET	1	
5*	5117	COTTER PIN, 1/16 X 1/2	1	
6*	8167	CLEVIS PIN, 1/4 X 1-1/2 PLATED	1	
7*		SHROUD FASTENER	1	SUPPLIED IN KIT ONLY
8	EM504050	COVER, PUMP AND CONTROLS	1	
9	EM969079	NUT, NYLOC 1/4 -20	18	
10	492355	SCREW, HHC 1/4 20 X 1/2	18	
11	EM503740	HINGE, COVER	3	
12	EM504051	COVER, BELT	1	
13	EM923023	WASHER, FLAT 5/16"	4	
14	EM923343	WASHER, LOCK 5/16	4	
15	492363	SCREW, HHC 5/16 - 18 X 3/4	5	
16	EM510091	PLATE, ENGINE BASE	1	
17	3019092	WASHER, FLAT 3/8	4	
18	EM963057	SCREW, HHC 3/8 - 16 X 1-1/2	4	
19	0166A	WASHER, LOCK 3/8	4	
20	EM492263	SCREW, ALLEN 3/8 - 16 X 3/4	4	
21	492582	NUT, NYLOC 5/16 - 18	1	
22	EM505652	BASE SWITCH	1	
23*		FLAT WASHER	1	SUPPLIED IN KIT ONLY
24*		BRACKET, LATCH HOLDER	1	SUPPLIED IN KIT ONLY
25	EM106395	WATER TANK EXPANSION PLUG	1	
26	EM505641	FRAME	1	

V30-4 — TRANSPORT HOOKS ASSY.

TRANSPORT HOOKS ASSY.

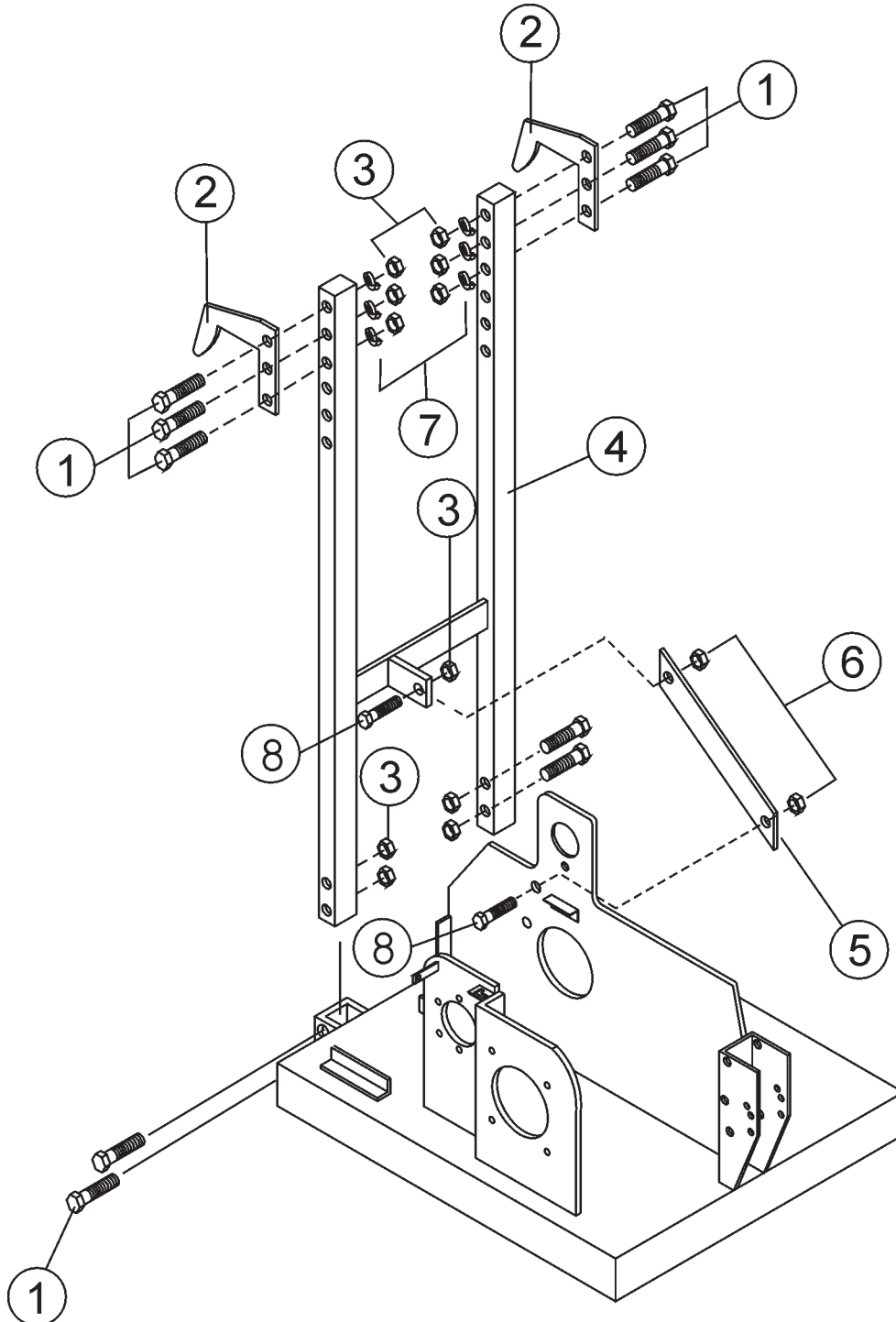

V30-4 — TRANSPORT HOOKS ASSY.

TRANSPORT HOOKS ASSY.

<u>NO</u>	<u>PART NO</u>	<u>PART NAME</u>	<u>QTY.</u>	<u>REMARKS</u>
1	EM492421	SCREW, HHC 3/4 - 10 X 3-1/2	6	
2	EM502677	HOOK, HANGER	2	
3	EM968446	NUT, HEX 3/4 - 10	6	
4	EM505396	CARRYING, HANGER	1	
5	EM511866	BRACKET, STRUT	1	
6	EM969023	NUT, NYLOC 5/8 - 11	2	
7	EM923350	WASHER, LOCK 3/4	6	
8	EM492406	SCREW, HHC 5/8 - 11 X 1-1/2	1	

V30-4 — PUMP DRIVE ASSY.

PUMP DRIVE ASSY.

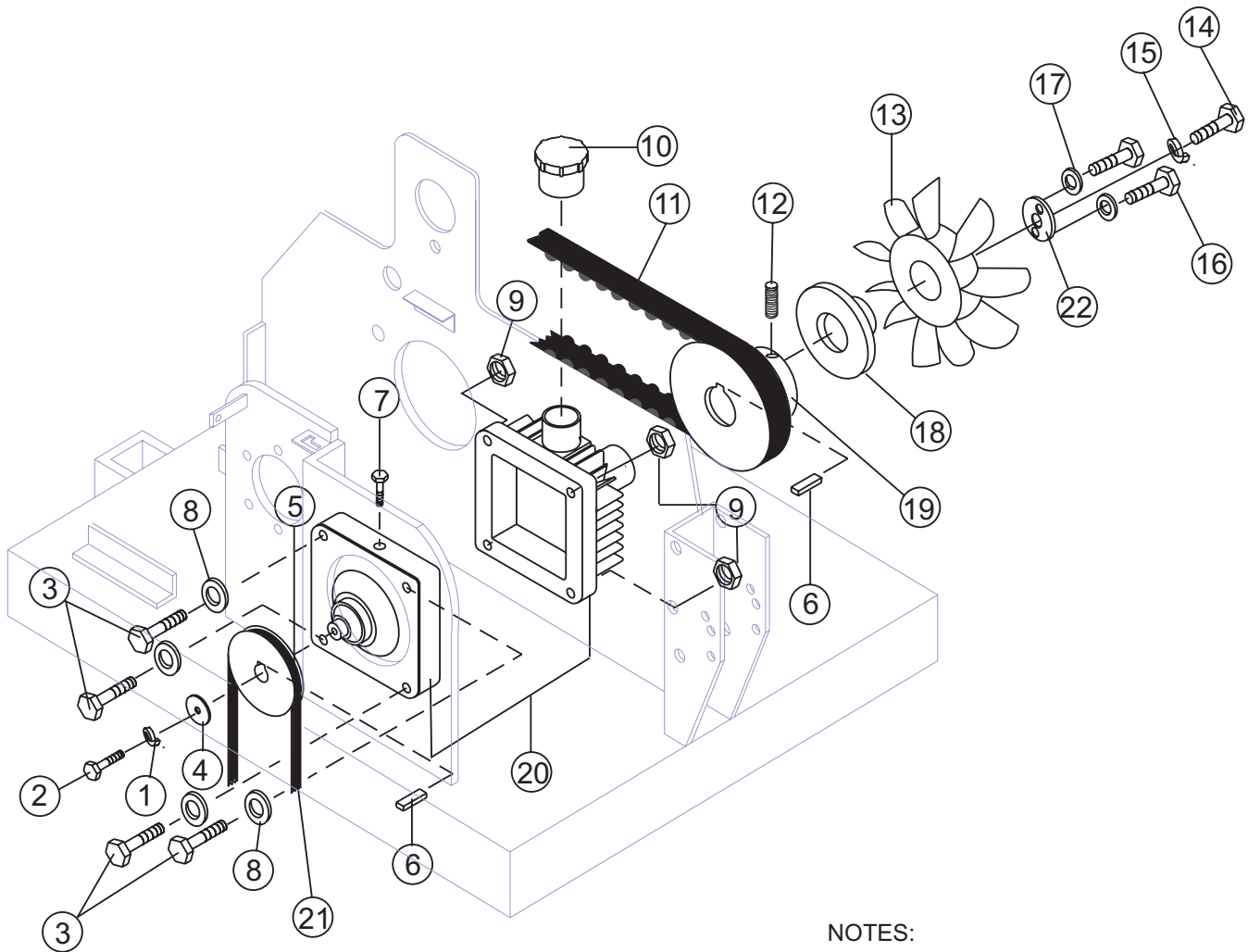

NOTES:

- △ INCLUDED WITH HYDROSTATIC PUMP, ITEM 20.

PUMP DRIVE ASSY.

<u>NO</u>	<u>PART NO</u>	<u>PART NAME</u>	<u>QTY.</u>	<u>REMARKS</u>
1	492622	WASHER, LOCK 1/4	1	
2	EM963003	SCREW, HHC 1/4 - 20 X 3/4	1	
3	EM490166	SCREW, HHC 3/8 - 16 X 3-1/2	4	
4	EM491086	WASHER, FLAT PULLEY	1	
5	EM490300	PULLEY, TRAVEL	1	
6	EM491759	KEY, WOODRUFF 1/8 X 1/2	2	
7	TBD	SCREW	1	
8	EM504679	WASHER, 3/8	4	
9	492583	NUT, NYLOC 3/8 - 16	4	
10*		HYDRAULIC RESERVOIR/CAP	1	
11	EM491132	BELT, ENGINE TO PUMP DRIVE	1	
12	EM503110	SCREW, SET 1/4 - 20 X 1/4	1	
13	EM493150	FAN	1	
14	492369	SCREW, HHC 1/4 - 20 X 1-1/2	1	
15	2101402	WASHER, LOCK 1/4	1	
16	EM503115	SCREW, HHC 3/16- 24 X 3/4	2	
17	3103160	WASHER, LOCK 3/16	2	
18	502651	SPACER, FAN	1	
19	EM491033	PULLEY, DRIVEN BELT	1	
20	EM510971	PUMP, HYDROSTATIC	1INCLUDES ITEM/*
21	EM491116	V-BELT, DRIVE	1	
22	EM502650	WASHER, FAN SECURING	1	

V30-4 — VIBRATORY DRIVE ASSY.

VIBRATORY DRIVE ASSY.

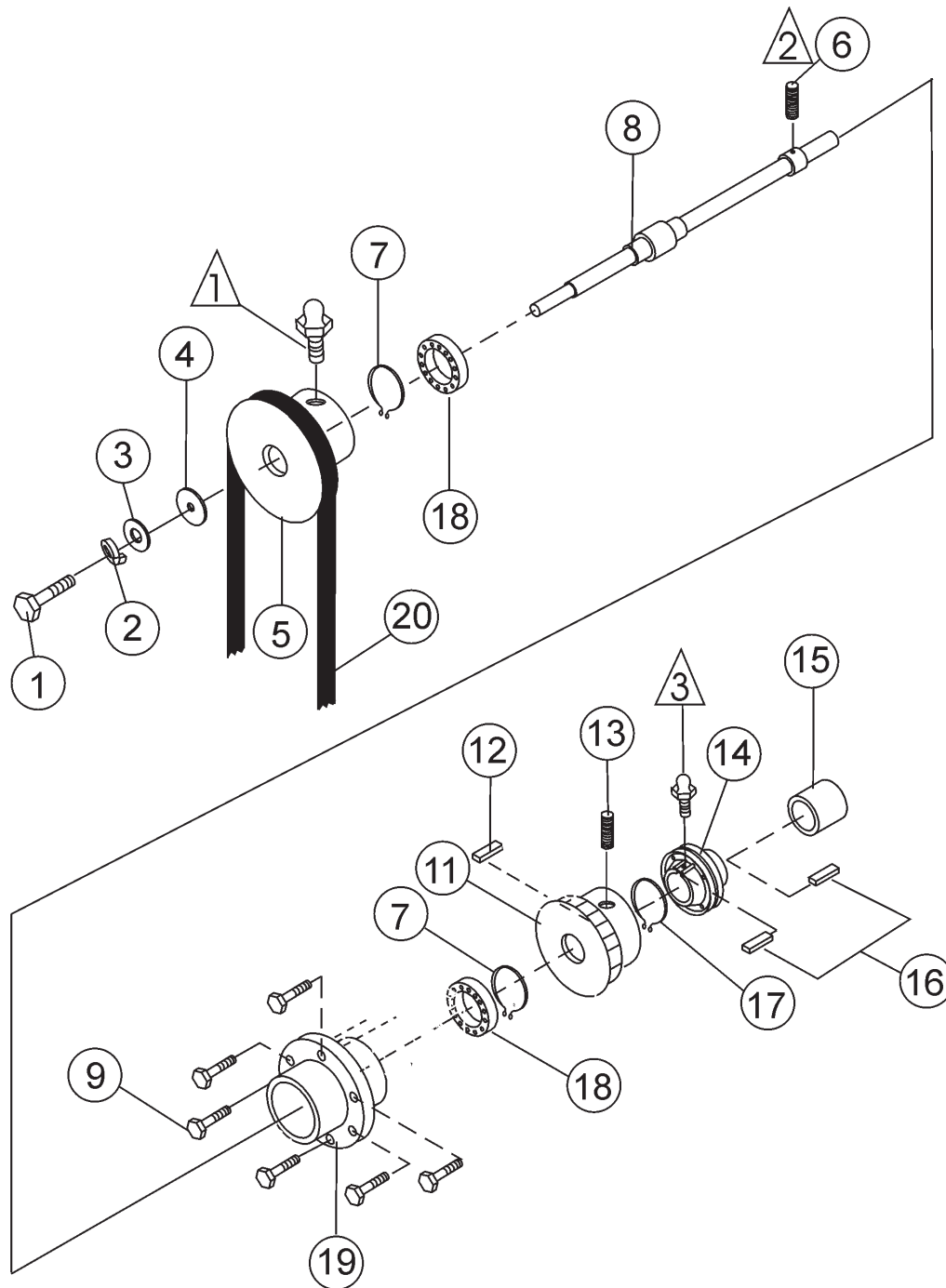

NOTES:

- △ INCLUDED WITH PULLEY CLUTCH, ITEM 5.
- △ INCLUDED WITH VIBRATORY SHAFT, ITEM 8.
- △ INCLUDED WITH ENGINE COUPLER, ITEM 14.

V30-4 — VIBRATORY DRIVE ASSY.

VIBRATORY DRIVE ASSY.

<u>NO</u>	<u>PART NO</u>	<u>PART NAME</u>	<u>QTY.</u>	<u>REMARKS</u>
1	EM963003	SCREW, HHC 1/4 - 20 X 3/4	1	
2	492622	WASHER, LOCK 1/4	1	
3	EM504451	WASHER, FLAT 1/4	1	
4	EM502630	SPACER	1	
5	EM502133	CLUTCH ASSY.	1	
6*		SET SCREW	1	
7	EM9260967	RING, SNAP	2	
8	EM500131	SHAFT, ENGINE DRIVE	1	INCLUDES ITEM/*
9	EM492365	SCREW, HHC 5/16 - 18 X 1-1/4	6	
11	EM491032	PULLEY, DRIVE BELT	1	
12	EM502625	KEY, 1/4 X 25MM	1	
13	492468	SCREW, SET 5/16 - 18 X 1/2	1	
14	EM500133	COUPLING, ENGINE SHAFT	1	
15	EM510131	BUSHING, ENGINE SHAFT	1	
16	EM500194	KEY, 1/4 X 25MM	2	
17	JISB2804C25	RING, SNAP	1	
18	492179	BEARING, FLANGE	2	
19	EM502629	FLANGE, ENGINE DRIVE SUPPORT	1	
20	EM504233	V-BELT, VIBRATORY DRIVE	1	

V30-4 — VIBRATORY ROLL ASSY.

VIBRATORY ROLL ASSY.

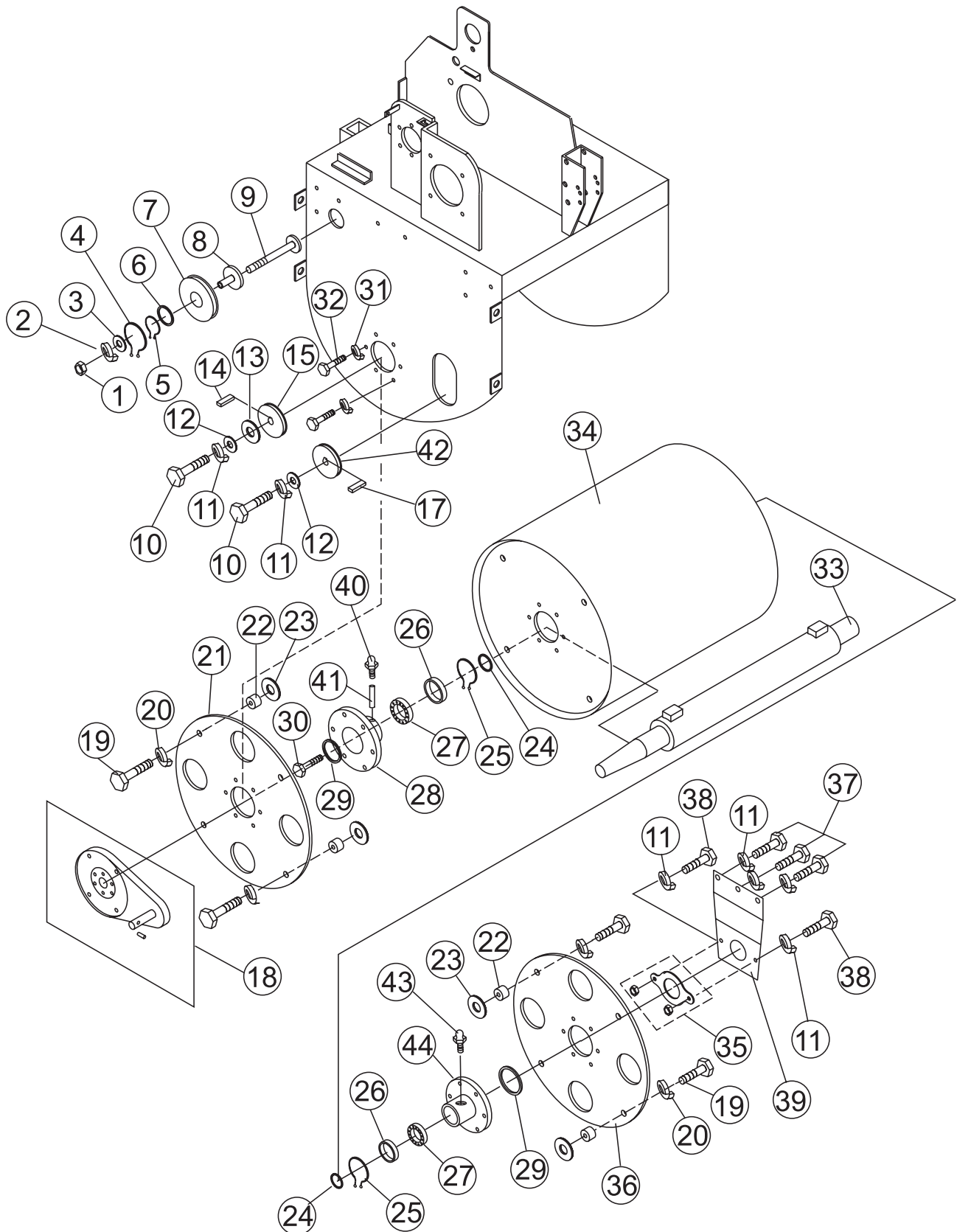

V30-4 — VIBRATORY ROLL ASSY.

VIBRATORY ROLL ASSY.

<u>NO</u>	<u>PART NO</u>	<u>PART NAME</u>	<u>QTY.</u>	<u>REMARKS</u>
1	EM492555	NUT, HEX 7/16 - 14	1	
2	EM492625	WASHER, LOCK 7/16	1	
3	EM492599	WASHER, FLAT 7/16	1	
4	EM490981	RING, SNAP	1	
5	EM490951	RING, SNAP	1	
6	EM490163	BEARING, IDLER PULLEY	1	
7	EM502134	PULLEY, IDLER PULLEY	1	
8	EM502646	BUSHING, IDLER PULLEY	1	
9	EM502645	SHAFT, IDLER PULLEY	1	
10	EM492356	SCREW, HHC 1/4 - 20 X 3/4	1	
11	EM492622	WASHER, LOCK 1/4	11	
12	EM491086	WASHER, FLAT 1/4	1	
13	EM501299	WASHER, FLAT FENDER 1/4	1	
14	EM502625	KEY, 1/4 X 1	1	
15	EM502135	PULLEY, VIBRATORY CONTROL	1	
16	EM490300	PULLEY, GEAR DRIVE	1	
17	EM491759	KEY, WOODRUFF 1/8 X 1/2	1	
18	EM500913	DRIVE, GEAR REDUCTION ASSY.	1	
19	EM504456	SCREW, 1/2 - 13 X 3/4	5	
20	EM492626	WASHER, LOCK 1/2	5	
21	EM503992	PLATE, DRIVE SUPPORT	1	
22	EM504441	MOUNT, SHOCK	5	
23	EM504457	WASHER, FLAT FENDER 9/16	5	
24	EM509470	WASHER	2	
25	EM490985	RING, SNAP	2	
26	EM502538	CAP, BEARING	2	
27	EM492160	BEARING, SHAFT	2	
28	511771	HOUSING, LH BEARING, CLOSED	1	
29	EM511777	SEAL	2	
30	EM492299	SCREW, HHC 5/16 - 18 X 1/2	2	
31	EM492625	WASHER, LOCK 7/16	12	
32	EM492453	SCREW, HHC 7/16 - X 1	12	
33	EM511775	SHAFT, ECCENTRIC VIBRATORY	1	
34	504741	ROLLER	1	
35	EM512272	BEARING, PILLOW BLOCK ASSY.	1	
36	EM503990	PLATE, ROLLER SUPPORT	1	
37	EM492396	SCREW, HHC 1/2 - 13 X 2	3	
38	492395	SCREW, HHC 1/2 - 13 X 1- 3/4	2	
39	EM505010	SUPPORT, ROLLER	1	
40	EM916019	GREASE FITTING	1	
41	EM510520	EXTENSION, ZERK	1	
42	EM490300	PULLEY, GEAR DRIVE	1	
43	EM491703	ZERK FITTING 1/8 NPT	1	
44	EM503655	HOUSING, RH BEARING, OPEN	1	

BATTERY ASSY.

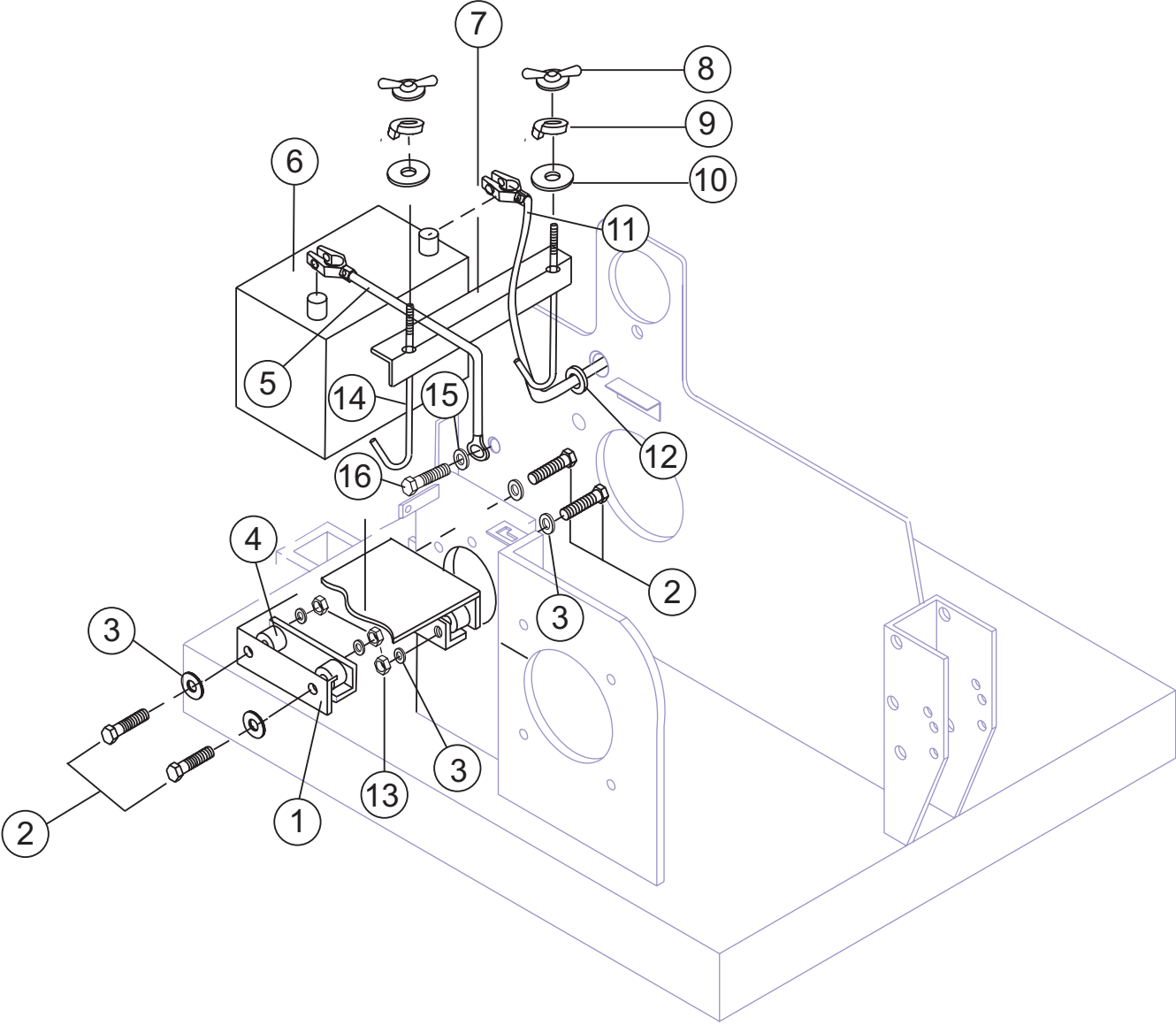

BATTERY ASSY.

<u>NO</u>	<u>PART NO</u>	<u>PART NAME</u>	<u>QTY.</u>	<u>REMARKS</u>
1	EM507583	BASE, BATTERY MOUNTING	1	
2	505401	SCREW, HHC 5/16 - 18 X 1/2	4	
3	EM923343	WASHER, LOCK 5/16	8	
4	EM505201	BUSHING, RUBBER SHOCK	4	
5	EM507591C	CABLE, NEGATIVE BATTERY	1	
6	507590	BATTERY 12V.	1	
7	EM506429	BRACKET, BATTERY HOLD-DOWN	1	
8	EM505333	NUT, WING 5/16 - 18	2	
9	EM923343	WASHER, LOCK 5/16	2	
10	EM923023	WASHER, FLAT 9.5 X 22.2	2	
11	EM506302C	CABLE, POSITIVE BATTERY	1	
12	EM505249	GROMMET	1	
13	492553	NUT, HEX 5/16 - 18	4	
14	EM506430	HOOK, BATTERY HOLD-DOWN	2	
15	EM963610	SCREW, HHC 3/8 - 16 X 1-1/4	1	
16	3019092	WASHER, FLAT 3/8	1	

SPRAY ASSY.

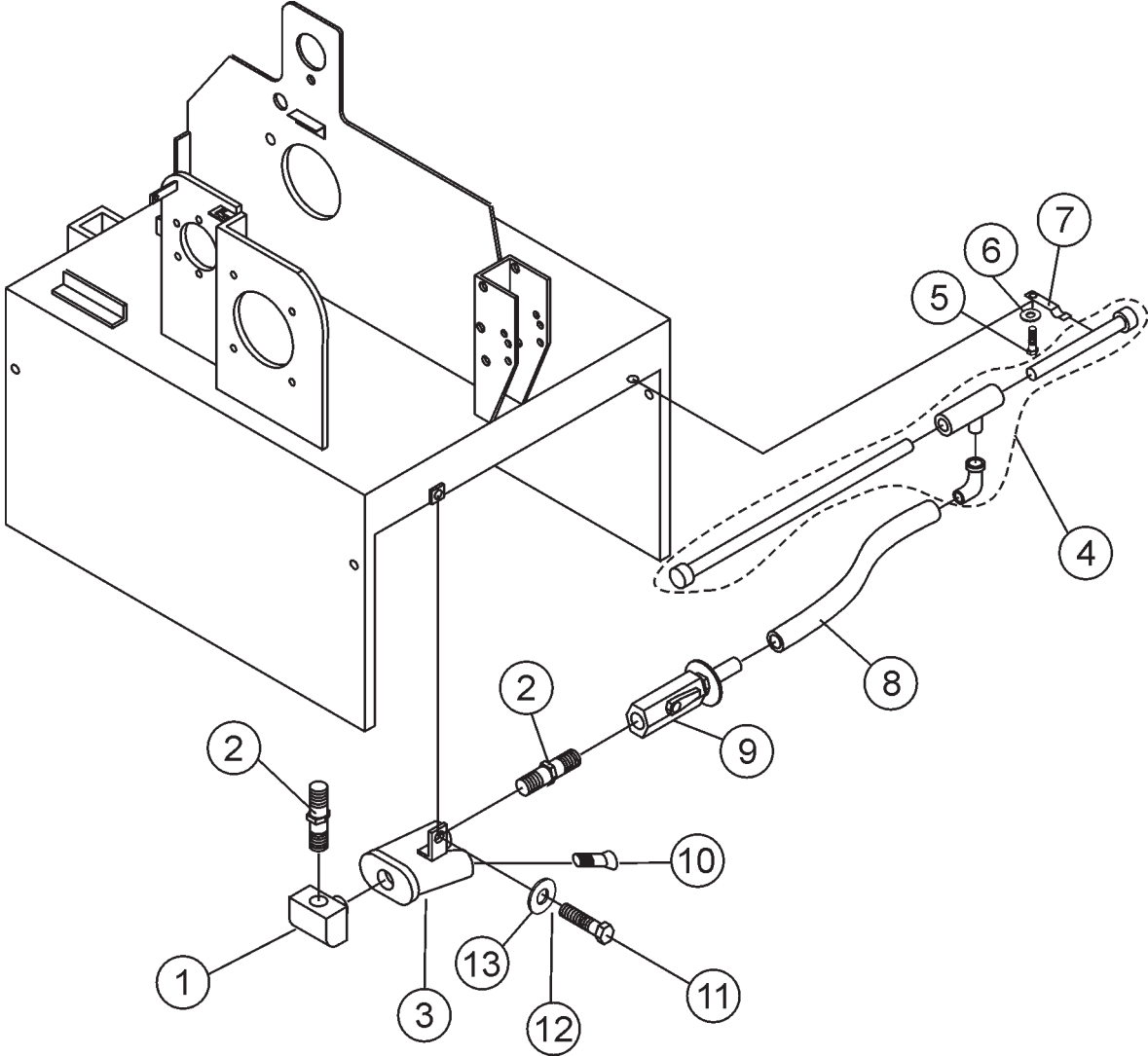

SPRAY ASSY.

<u>NO</u>	<u>PART NO</u>	<u>PART NAME</u>	<u>QTY.</u>	<u>REMARKS</u>
1	EM491260	ELBOW, CONNECTOR	1	
2	EM508578	CONNECTOR	1	
3	EM508582	FILTER, Y-CONNECTOR	1	
4	EM508614	BAR ASSY.	1	
5	492364	SCREW, HHC 5/16 - 18 X 1	2	
6	EM923343	WASHER, LOCK 5/16	2	
7	351104770	CLAMP	2	
8	EM508615	HOSE	1	
9	EM505144	VALVE, SHUT-OFF	1	
10	EM508579	PLUG	1	
11	492373	SCREW, HHC 3/8 - 16 X 3/4	1	
12	0166A	WASHER, LOCK 3/8	1	
13	EM504679	WASHER, 3/8	1	

TRANSMISSION

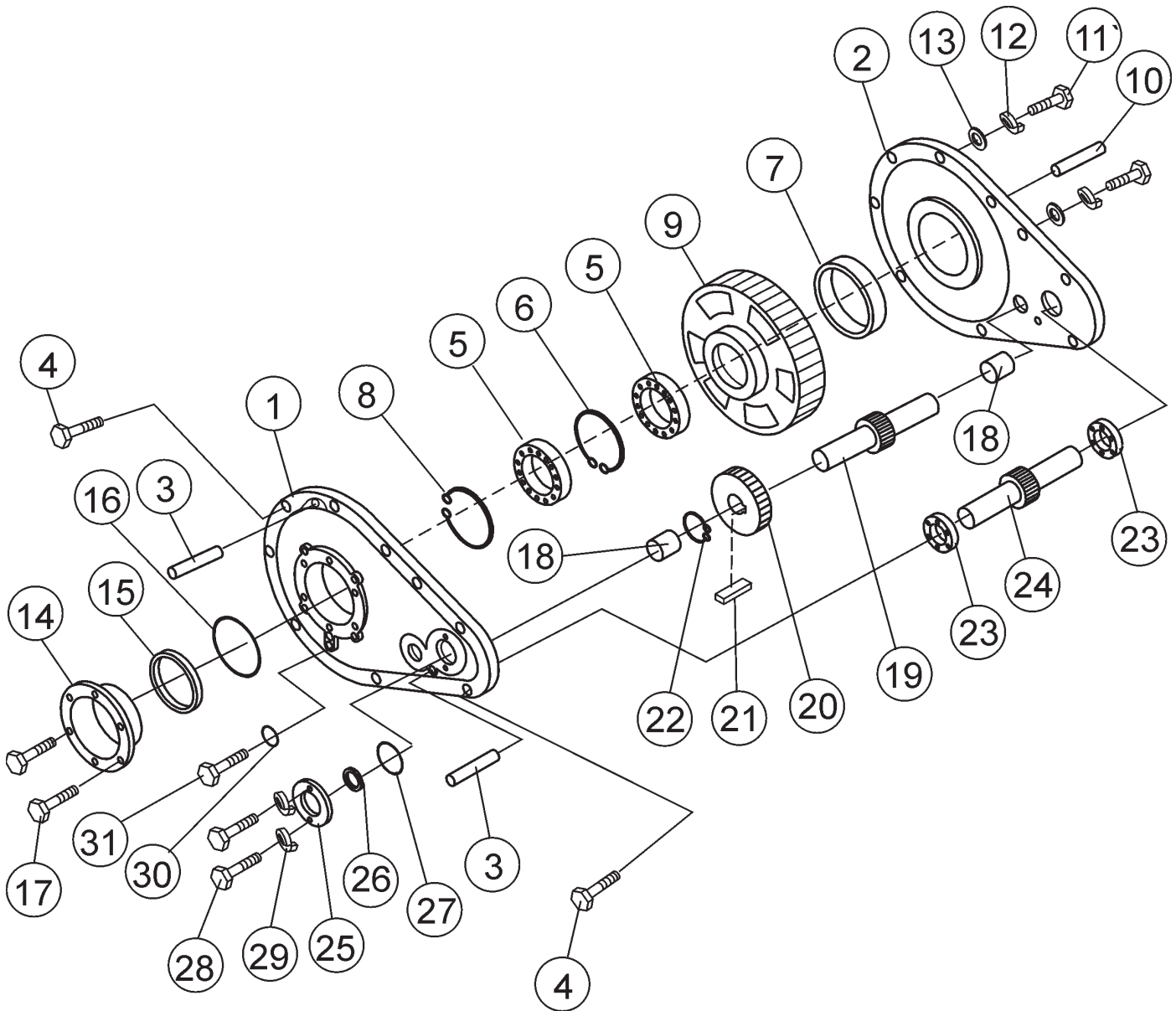

TRANSMISSION

<u>NO</u>	<u>PART NO</u>	<u>PART NAME</u>	<u>QTY.</u>	<u>REMARKS</u>
1*	EM502546	TRANSMISSION BASE BOX	1	
2*	EM502547	TRANSMISSION COVER BOX	1	
3*	EM491722	SPIRAL PIN	2	
4*	EM492302	SPECIAL CAP SCREW	9	
5*	EM492228	BEARING	2	
6*	EM490990	INTERNAL RETAINING RING	1	
7*	EM492123	SEAL	1	
8*	EM490968	EXTERNAL RETAINING RING	1	
9*	EM503802	GEAR	1	
10*	EM503803	PIN	2	
11*	492451	SPECIAL CAP SCREW	6	
12*	0166A	LOCK WASHER, 3/8"	6	
13*	3019092	FLAT WASHER, 3/8"	6	
14*	EM502556	COVER	1	
15*	EM492122	SEAL	1	
16*	EM491057	O-RING	1	
17*	EM492258	HEX SOCKET HEAD BOLT	6	
18*	EM492229	BEARING	2	
19*	EM502550	SHAFT	1	
20*	EM502552	GEAR	1	
21*	EM502551	KEY	1	
22*	EM490952	EXTERNAL RETAINING RING	1	
23*	EM492212	BEARING	2	
24*	EM502553	SHAFT	1	
25*	EM502555	COVER	1	
26*	EM492108	SEAL	1	
27*	EM491058	O-RING	1	
28*	EM492254	HEX SOCKET HEAD BOLT	2	
29*	2101402	LOCK WASHER, 1/4"	2	
30*	EM491056	O-RING	2	
31*	EM492325	CAP SCREW	2	
32	EM500913	TRANSMISSION ASSY.	1	INCLUDES ITEM/*

PAYMENT TERMS

Terms of payment for parts are net 30 days.

FREIGHT POLICY

All parts orders will be shipped collect or prepaid with the charges added to the invoice. All shipments are F.O.B. point of origin. Multiquip's responsibility ceases when a signed manifest has been obtained from the carrier, and any claim for shortage or damage must be settled between the consignee and the carrier.

MINIMUM ORDER

The minimum charge for orders from Multiquip is \$15.00 net. Customers will be asked for instructions regarding handling of orders not meeting this requirement.

RETURNED GOODS POLICY

Return shipments will be accepted and credit will be allowed, subject to the following provisions:

1. A Returned Material Authorization must be approved by Multiquip prior to shipment.
2. To obtain a Return Material Authorization, a list must be provided to Multiquip Parts Sales that defines item numbers, quantities, and descriptions of the items to be returned.
 - a. The parts numbers and descriptions must match the current parts price list.
 - b. The list must be typed or computer generated.
 - c. The list must state the reason(s) for the return.
 - d. The list must reference the sales order(s) or invoice(s) under which the items were originally purchased.
 - e. The list must include the name and phone number of the person requesting the RMA.
3. A copy of the Return Material Authorization must accompany the return shipment.
4. Freight is at the sender's expense. All parts must be returned freight prepaid to Multiquip's designated receiving point.

5. Parts must be in new and resalable condition, in the original Multiquip package (if any), and with Multiquip part numbers clearly marked.
6. The following items are not returnable:
 - a. Obsolete parts. (If an item is in the price book and shows as being replaced by another item, it is obsolete.)
 - b. Any parts with a limited shelf life (such as gaskets, seals, "O" rings, and other rubber parts) that were purchased more than six months prior to the return date.
 - c. Any line item with an extended dealer net price of less than \$5.00.
 - d. Special order items.
 - e. Electrical components.
 - f. Paint, chemicals, and lubricants.
 - g. Decals and paper products.
 - h. Items purchased in kits.
7. The sender will be notified of any material received that is not acceptable.
8. Such material will be held for five working days from notification, pending instructions. If a reply is not received within five days, the material will be returned to the sender at his expense.
9. Credit on returned parts will be issued at dealer net price at time of the original purchase, less a 15% restocking charge.
10. In cases where an item is accepted, for which the original purchase document can not be determined, the price will be based on the list price that was effective twelve months prior to the RMA date.
11. Credit issued will be applied to future purchases only.

PRICING AND REBATES

Prices are subject to change without prior notice. Price changes are effective on a specific date and all orders received on or after that date will be billed at the revised price. Rebates for price declines and added charges for price increases will not be made for stock on hand at the time of any price change.

Multiquip reserves the right to quote and sell direct to Government agencies, and to Original Equipment Manufacturer accounts who use our products as integral parts of their own products.

SPECIAL EXPEDITING SERVICE

A \$35.00 surcharge will be added to the invoice for special handling including bus shipments, insured parcel post or in cases where Multiquip must personally deliver the parts to the carrier.

LIMITATIONS OF SELLER'S LIABILITY

Multiquip shall not be liable hereunder for damages in excess of the purchase price of the item with respect to which damages are claimed, and in no event shall Multiquip be liable for loss of profit or good will or for any other special, consequential or incidental damages.

LIMITATION OF WARRANTIES

No warranties, express or implied, are made in connection with the sale of parts or trade accessories nor as to any engine not manufactured by Multiquip. Such warranties made in connection with the sale of new, complete units are made exclusively by a statement of warranty packaged with such units, and Multiquip neither assumes nor authorizes any person to assume for it any other obligation or liability whatever in connection with the sale of its products. Apart from such written statement of warranty, there are no warranties, express, implied or statutory, which extend beyond the description of the products on the face hereof.

OPERATION AND PARTS MANUAL

HERE'S HOW TO GET HELP

PLEASE HAVE THE MODEL AND SERIAL
NUMBER *ON-HAND* WHEN CALLING

UNITED STATES

Multiquip Corporate Office

18910 Wilmington Ave. Tel. (800) 421-1244
Carson, CA 90746 Fax (800) 537-3927
Contact: mq@multiquip.com

Mayco Parts

800-306-2926 Fax: 800-672-7877
310-537-3700 Fax: 310-637-3284

Service Department

800-421-1244 Fax: 310-537-4259
310-537-3700

MQ Parts Department

800-427-1244 Fax: 800-672-7877
310-537-3700 Fax: 310-637-3284

Warranty Department

800-421-1244, Ext. 279 Fax: 310-537-1173
310-537-3700, Ext. 279

Technical Assistance

800-478-1244 Fax: 310-631-5032

MEXICO

MQ Cipsa

Carr. Fed. Mexico-Puebla KM 126.5 Tel: (52) 222-225-9900
Momoxpan, Cholula, Puebla 72760 Mexico Fax: (52) 222-285-0420
Contact: pmastretta@cipsa.com.mx

CANADA

Multiquip

4110 Industriel Boul. Tel: (450) 625-2244
Laval, Quebec, Canada H7L 6V3 Fax: (450) 625-8664
Contact: jmartin@multiquip.com

UNITED KINGDOM

Multiquip (UK) Limited Head Office

Hanover Mill, Fitzroy Street, Tel: 0161 339 2223
Ashton-under-Lyne, Fax: 0161 339 3226
Lancashire OL7 0TL
Contact: sales@multiquip.co.uk

BRAZIL

Multiquip

Av. Evandro Lins e Silva, 840 - grupo 505 Tel: 011-55-21-3433-9055
Barra de Tijuca - Rio de Janeiro Fax: 011-55-21-3433-9055
Contact: cnavarro@multiquip.com.br, srentes@multiquip.com.br

© COPYRIGHT 2006, MULTIQUIP INC.

Multiquip Inc, the MQ logo are registered trademarks of Multiquip Inc. and may not be used, reproduced, or altered without written permission. All other trademarks are the property of their respective owners and used with permission.

This manual MUST accompany the equipment at all times. This manual is considered a permanent part of the equipment and should remain with the unit if resold.

The information and specifications included in this publication were in effect at the time of approval for printing. Illustrations are based on the *V30-4 VIBRATORY ROLLER*. Illustrations, descriptions, references and technical data contained in this manual are for guidance only and may not be considered as binding. Multiquip Inc. reserves the right to discontinue or change specifications, design or the information published in this publication at any time without notice and without incurring any obligations.

Your Local Dealer is:

