

ITEM NO.	QTY.	PART NUMBER	Description
1	1	HF-1001	LOWER GEAR BLOCK
2	1	CRBE-1006	UPPER GEAR BLOCK
3	1	CRBE-1003	TOP ADJUSTMENT BLOCK
4	1	HF-1009	BOTTOM POST ASSEMBLY
5	2	CRBE-1002	SIDE PLATE
6	1	HF-A-2022	CLAMP ASSEMBLY
7	1	CRBE-1004	GEARED TOP SHAFT
8	1	CRBE-1005	GEARED BOTTOM SHAFT
9	1	HF-1015	TOP HANDLE (LONG)
10	1	HF-1012	HANDLE ARM (LONG)
11	1	HF-1010	BRASS PUCK
12	1	HF-1013	HANDLE ARM (SHORT)
13	1	HF-1014	TOP HANDLE (SHORT)
14	1	HF-1017	SPUR GEAR
15	1	CRBE-1019	LOWER SPUR GEAR
16	2	HF-1018	WASHER
17	1	HF-1023	CLAMP THREADED ROD
18	1	HF-1024	CLAMP PUCK
19	1	HF-1025	T-HANDLE
20	2	HF-1027	LOCK INSERT: 1/4-20 INTERNAL X 7/16-14 EXTERNAL
21	1	HF-1029	LOCK INSERT 5/8-11 INTERNAL X 7/8-14 EXTERNAL
22	4	HF-1035	BEARING: PRT # B-128
23	1	.787 tall spring	SPRING
24	4	HHCS CS .25-20 X .50	HH CAP SCREW, CS 1/4-20 X 1/2
25	4	HHCS CS .25-20 X .75	HH CAP SCREW, CS 1/4-20 X 3/4
26	2	WASHER-FLAT CS .25	1/4" FLAT WASHER,ZINC PLATED
27	2	DOWELPIN .25X.75	1/4" DIA X 1" LONG DOWEL PIN
28	4	SETSCR BO .25-20 x .38	1/4-20 X 3/8 SH SET SCREW 1/4-20 X 1/2, BLACK OXIDE
29	1	SSCUPSKT 0.19-32x0.375-HX-N	SOCKET SET SCREW #10-32 X 3/8
30	1	E RING .44	E-RING 7/16" DIA SHAFT
31	1	CRBE-1001	THREADED ADJUSTING ROD, TOP
32	1	THR INS .5-13 TO .75-16 BO	THREADED INSERT INT 1/2-13 EXT 3/4-16 BLACK OXIDE
33	8	HHCS CS .25-20 X .63	HH CAP SCREW, CS 1/4-20 X 5/8
34	1	CRBE-1007	ADJUSTING WHEEL
35	1	CRBE-1008	ADJUSTING PIN
36	1	CRBE-1009	GUIDE BLOCK
37	2	HHCS CS .25-20 X 1.25	HH CAP SCREW, CS 1/4-20 X 1-1/4
38	1	KNOB 101	KNOB-GRIP, 906643 ELESA
39	1	CRBE-2001	WELDMENT-GUIDE
40	1	DOWELPIN .19 X 1.75	1/4" DIA X 1" LONG DOWEL PIN
41	2	SHCS BO .375-16 X 2.50	SHCS 3/8-16 X 2-1/2 BLACK OXIDE
42	1	OGB-1010	BOTTOM FORMING ROLL
43	1	OGB-1011	TOP FORMING ROLL

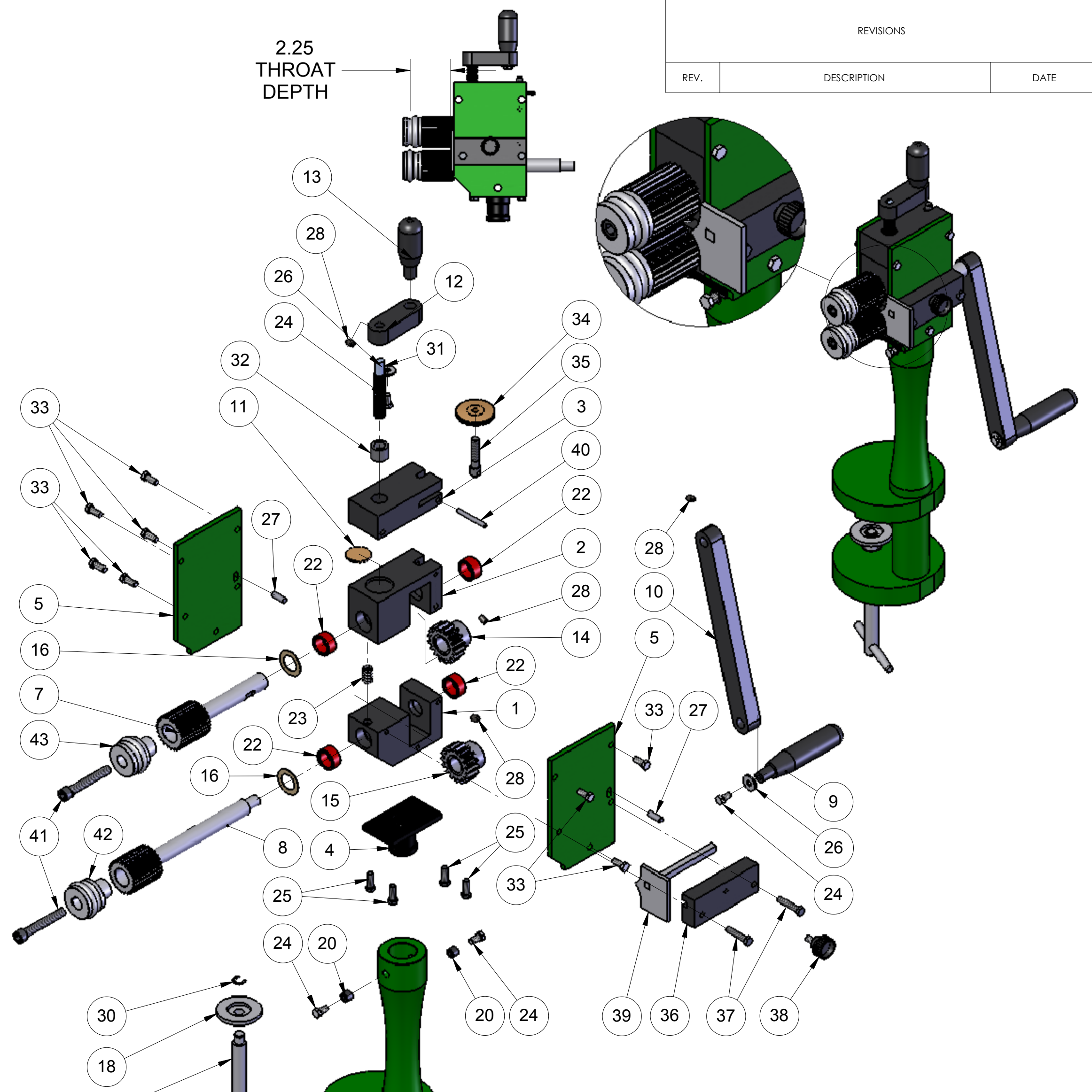

REVISIONS		
REV.	DESCRIPTION	DATE

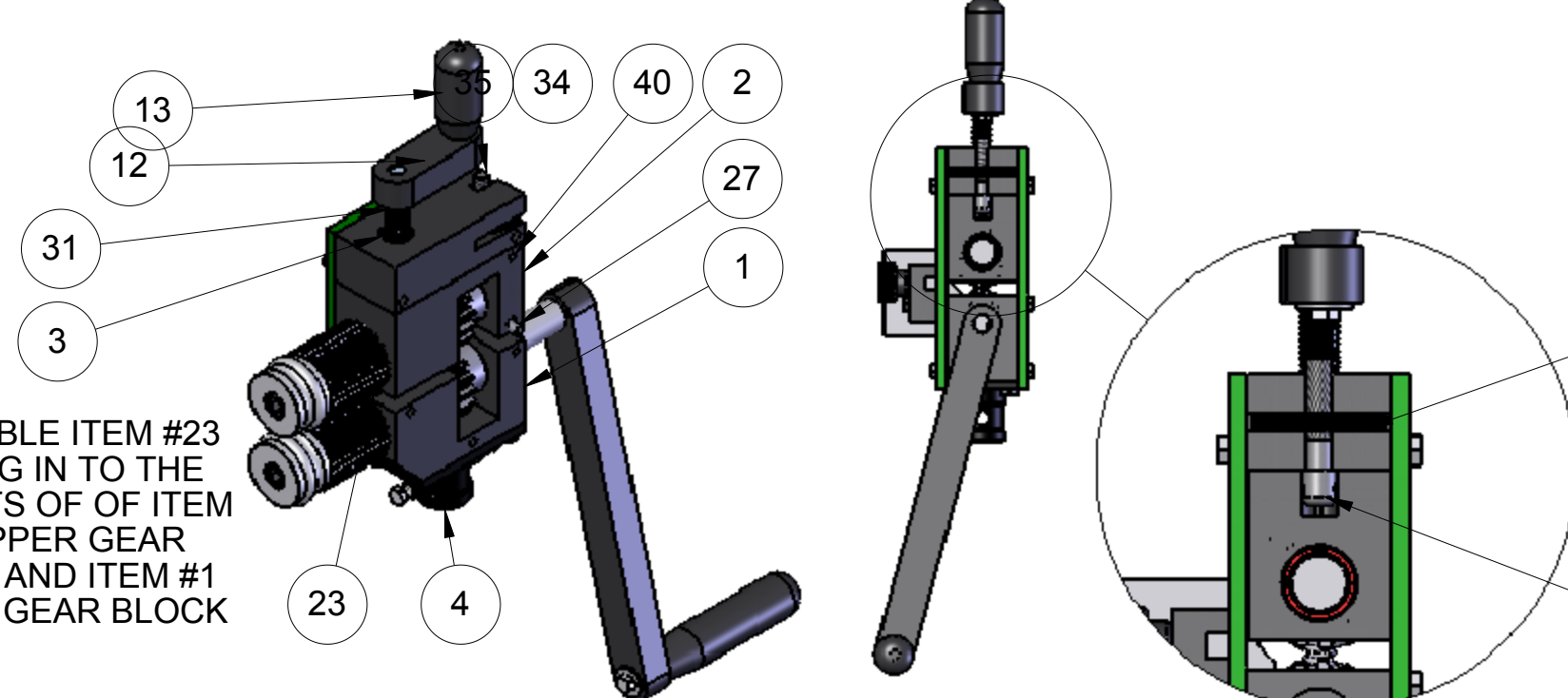

ASSEMBLE ITEM #23 SPRING IN TO THE POCKETS OF OF ITEM #2 UPPER GEAR BLOCK AND ITEM #1 LOWER GEAR BLOCK

STANDARD RAMS-2010 CONTAINS FORMING ROLLERS FOR OGEE BEAD WITH 2-1/4 THROAT DEPTH

RAMS-2010 CRIMPER/BEADER

DIMENSIONS ARE IN INCHES
 TOLERANCES:
 FRACTIONAL ± 1/16
 ANGULAR: MACH ± BEND ±
 TWO PLACE DECIMAL ±.01
 THREE PLACE DECIMAL ±.005

DRAWN		NAME	DATE	HORIZON SYSTEMS MACHINING 9121 58TH PLACE KENOSHA, WI 53144 PH: 262-605-1122 FAX: 262-605-1198
CHECKED		CR	12-18-06	
ENG APPR.				
MFG APPR.				
Q.A.				
MATERIAL		TITLE: RAMS-2010 CRIMPER/BEADER		
FINISH		SIZE	DWG. NO.	REV
DO NOT SCALE DRAWING		C	RAMS-2010	
SCALE: 1:4		SHEET 1 OF 1		

THE INFORMATION CONTAINED IN THIS DRAWING IS THE SOLE PROPERTY OF HORIZON SYSTEMS MACHINING. ANY REPRODUCTION IN PART OR AS A WHOLE WITHOUT THE WRITTEN PERMISSION OF HORIZON SYSTEMS MACHINING IS PROHIBITED.