



# OPERATOR MANUAL

## MODELS: 45CM & 55CM



### CONCRETE MIXER

A 100% employee-owned American manufacturer



# TABLE of CONTENTS

45CM & 55CM

<b>FOREWORD</b> .....	<b>4</b>
<b>LIMITED WARRANTY</b> .....	<b>5</b>
<b>TECHNICAL DATA</b> .....	<b>6 - 8</b>
Specifications .....	6
Imperial Torque Chart .....	7
Metric Torque Chart .....	8
<b>HEALTH &amp; SAFETY</b> .....	<b>9 - 13</b>
<b>OPERATIONS</b> .....	<b>14 - 17</b>
Before Starting .....	14
Safety Chain Installation .....	14
Oil Levels and Lubrication .....	14
Hardware .....	14
Fuel .....	14
To Start the Engine/Motor .....	14 - 15
To Stop The Engine/Motor .....	15
Operation .....	15
General Mixing Instructions .....	15
Sample Mix .....	15
Cleaning .....	16
Towing .....	16
Maintenance Schedule .....	17
<b>CALIFORNIA PROPOSITION 65 WARNING</b> .....	<b>19</b>

# FOREWORD

---

These instructions include:

- Safety regulations
- Operating instructions
- Maintenance instructions

**These instructions have been prepared for operation on the construction site and for the maintenance engineer.**

These instructions are intended to simplify operation of the machine and to avoid malfunctions through improper operation.

Observing the maintenance instructions will increase the reliability and service life of the machine when used on the construction site and reduce repair costs and downtimes.

**Always keep these instructions at the place of use of the machine.**

**Only operate the machine as instructed and follow these instructions.**

**Observe the safety regulations as well as the guidelines of the civil engineering trade association. Observe the safety rules for operation and the pertinent regulations for the prevention of accidents.**

Stone Construction Equipment, Inc. is not liable for the function of the machine when used in an improper manner or for other than the intended purpose.

Operating errors, improper maintenance and the use of incorrect operating materials are not covered by the warranty.

The above information does not extend the warranty and liability conditions of business of Stone Construction Equipment, Inc.

Please enter (data on machine type plate)

Machine Type: \_\_\_\_\_

Machine No.: \_\_\_\_\_

Engine Type: \_\_\_\_\_

Engine No.: \_\_\_\_\_

---

Stone Construction Equipment, Inc.  
P.O. Box 150, Honeoye, New York 14471  
Phone: (800) 888-9926  
Fax: (716) 229-2363

## Limited Warranty

The Manufacturer warrants that products manufactured shall be free from defects in material and workmanship that develop under normal use for a period of 90 days for concrete vibrators and electric pumps, one year for Rhino®, Bulldog®, Wolfpac Rollers™, trowels, Stompers®, saws, forward plates, engine powered pumps, and 6 months for all other products from the date of shipment. The foregoing shall be the exclusive remedy of the buyer and the exclusive liability of the Manufacturer. Our warranty excludes normal replaceable wear items, i.e. gaskets, wear plates, seals, O-rings, V-belts, drive chains, clutches, etc. Any equipment, part or product which is furnished by the Manufacturer but manufactured by another, bears only the warranty given by such other manufacturer. (The Manufacturer extends the warranty period to "Lifetime" for the drum bearings and seals for the mortar mixers, and agrees to furnish, free of charge, the bearings and seals only upon receipt of the defective parts. The warranty is two years for eccentric bearings on the forward plate compactors, mortar and plaster mixer drums, trowel gearboxes and five years on the Bulldog trench roller eccentric bearings.) A Warranty Evaluation Form must accompany all defective parts. Warranty is voided by product abuse, alterations, and use of equipment in applications for which it was not intended, use of non-manufacturer parts, or failure to follow documented service instructions. The foregoing warranty is exclusive of all other warranties whether written or oral, expressed or implied. No warranty of merchantability or fitness for a particular purpose shall apply. The agents, dealer and employees of Manufacturer are not authorized to make modification to this warranty, or additional warranties binding on Manufacturer. Therefore, additional statements, whether oral or written, do not constitute warranty and should not be relied upon.

The Manufacturer's sole responsibility for any breach of the foregoing provision of this contract, with respect to any product or part not conforming to the Warranty or the description herein contained, is at its option (a) to repair, replace or refund such product or parts upon the prepaid return thereof to location designated specifically by the Manufacturer. Product returns not shipped prepaid or on an economical transportation basis will be refused (b) as an alternative to the foregoing modes of settlement - the Manufacturer's dealer to repair defective units with reimbursement for expenses, except labor, and be reviewed with the Manufacturer prior to repair. A Warranty Evaluation Form must accompany all warranty claims.

Except as set forth hereinabove and without limitation of the above, there are no warranties or other affirmations which extends beyond the description of the products and the fact hereof, or as to operational efficiency, product reliability or maintainability or compatibility with products furnished by others. In no event whether as a result of breach of contract or warranty or alleged negligence, shall the Manufacturer be liable for special or consequential damages including but not limited to: Loss of profits or revenues, loss of use of the product or any associated product, cost of capital, cost of substitute products, facilities or services or claims of customers.

No claim will be allowed for products lost or damaged in transit. Such claims should be filed with the carrier within fifteen days.

Effective April 1, 1998.



Stone Construction Equipment, Inc.  
32 East Main Street, P. O. Box 150  
Honeoye, NY 14471-0150

Phone: 1-800-888-9926 • 1-716-229-5141

Fax: 1-716-229-2363

www.stone-equip.com • e-mail: sceny@mcimail.com

# TECHNICAL DATA

## Specifications

### Stone 45CM & 55CM Mixer – Specifications

	45CM	55CM
<u>Dimensions</u>		
Operating Wt.	418 lbs. (w/5hp Honda) 189.6 kg	425 lbs. (w/5hp Honda) 192.8 kg
Batch Capacity (Bags)	1/3 - 1/2 bags	1/2 - 2/3 bags
Batch Capacity (cu. ft.)	4 cu. ft. / .1 cu. m.	5 cu. ft. / .14 cu. m.
Total Volume	6.0 cu. ft. / .17 cu. m.	6.6 cu. ft. / .19 cu. m
L x W x H	70 x 46 x 56 (in) 177.8 x 116.8 x 142.2 (cm)	70 x 46 x 59 (in) 177.8 x 116.8 x 149.9 (cm)
Power Source	3/4 hp / 5.6 kW Electric 3.5 hp / 2.6 kW B&S 5 hp / 3.7 kW B&S 5 hp / 3.7 kW B&S I/P 5.5 hp / 4.1 kW Honda	3/4 hp / 5.6 kW Electric 3.5 hp / 2.6 kW B&S 5 hp / 3.7 kW B&S 5 hp / 3.7 kW B&S I/P 5.5 hp / 4.1 kW Honda

# TECHNICAL DATA

## Imperial Torque Chart

SAE GRADE 5 Coarse Thread, Zinc-Plated		
SIZE	TORQUE	
	ft. lbs.	Nm
1/4 - 20 (.250)	6	8
5/16 - 18 (.3125)	13	18
3/8 - 16 (.375)	23	31
7/16 - 14 (.4375)	37	50
1/2 - 13 (.500)	57	77
9/16 - 12 (.5625)	82	111
5/8 - 11 (.625)	112	152
3/4 - 10 (.750)	200	271
7/8 - 9 (.875)	322	436.5
1 - 8 (1.000)	483	655

SAE GRADE 8 Coarse Thread, Zinc-Plated		
SIZE	TORQUE	
	ft. lbs.	Nm
1/4 - 20 (.250)	9	12
5/16 - 18 (.3125)	18	24
3/8 - 16 (.375)	33	45
7/16 - 14 (.4375)	52	70
1/2 - 13 (.500)	80	108
9/16 - 12 (.5625)	115	156
5/8 - 11 (.625)	159	215
3/4 - 10 (.750)	282	382
7/8 - 9 (.875)	454	615
1 - 8 (1.000)	682	925

SAE GRADE 5 Fine Thread, Zinc-Plated		
SIZE	TORQUE	
	ft. lbs.	Nm
1/4 - 28 (.250)	7	10
5/16 - 24 (.3125)	14	19
3/8 - 24 (.375)	26	35
7/16 - 20 (.4375)	41	56
1/2 - 20 (.500)	64	87
9/16 - 18 (.5625)	91	123
5/8 - 18 (.625)	128	173
3/4 - 16 (.750)	223	302
7/8 - 14 (.875)	355	481
1 - 12 (1.000)	529	717
1 - 14 (1.000)	541	733

SAE GRADE 8 Fine Thread, Zinc-Plated		
SIZE	TORQUE	
	ft. lbs.	Nm
1/4 - 28 (.250)	10	14
5/16 - 24 (.3125)	20	27
3/8 - 24 (.375)	37	50
7/16 - 20 (.4375)	58	79
1/2 - 20 (.500)	90	122
9/16 - 18 (.5625)	129	175
5/8 - 18 (.625)	180	244
3/4 - 16 (.750)	315	427
7/8 - 9 (.875)	501	679
1 - 12 (1.000)	746	1011
1 - 14 (1.000)	764	1036

t-chrt\_i.doc

# TECHNICAL DATA

## Metric Torque Chart

### Property Class 8.8

ZINC-PLATED

SIZE	Coarse Thread		Fine Thread	
	Nm	ft. lbs.	Nm	ft. lbs.
M6	9.9	7	NA	NA
M8	24	18	25	18
M10	48	35	49	36
M12	83	61	88	65
M14	132	97	140	103
M16	200	148	210	155
M20	390	288	425	313
M24	675	498	720	531

### Property Class 10.9

ZINC-PLATED

SIZE	Coarse Thread		Fine Thread	
	Nm	ft. lbs.	Nm	ft. lbs.
M6	14	10	NA	NA
M8	34	25	35	26
M10	67	49	68	50
M12	117	86	125	92
M14	185	136	192	142
M16	285	210	295	218
M20	550	406	600	443
M24	950	701	1000	738

### Property Class 12.9

ZINC-PLATED

SIZE	Coarse Thread		Fine Thread	
	Nm	ft. lbs.	Nm	ft. lbs.
M6	16.5	12	NA	NA
M8	40	30	42	31
M10	81	60	82	60
M12	140	103	150	111
M14	220	162	235	173
M16	340	251	350	258
M20	660	487	720	531
M24	1140	841	1200	885

Conversion Factor: 1 ft. lb. = 1.3558 Nm

# HEALTH & SAFETY

## Safety Precautions

Before using this equipment, study this entire manual to become familiar with its operation. Do not allow untrained or unauthorized personnel, especially children, to operate this equipment. Use only factory authorized parts for service.

When warning decals are destroyed or missing, contact the Manufacturer immediately at 1-800-888-9926 for replacement. For the safety of yourself and others, it is imperative that the following rules are observed. Failure to do so may result in serious injury or death.

### FOLLOW SAFETY INSTRUCTIONS

Carefully read all safety messages and decals in this manual and on your machine safety signs. Keep decals in good condition. Replace missing or damaged decals. Be sure new equipment components and repair parts include the current safety signs. Replacement safety signs and decals are available through your dealer.

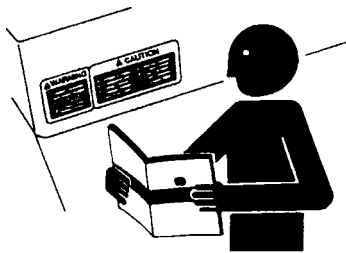

Learn how to operate the machine and how to use controls properly. Do not let anyone operate without instruction.

Keep your machine in proper working condition. Unauthorized modifications to the machine may impair the function and/or safety and affect machine life.

If you do not understand any part of this manual and need assistance, contact your dealer.



This notation appears before warnings in the text. It means that the step which follows must be carried out to avoid the possibility of personal injury or death. These warnings are intended to help the technician avoid any potential hazards encountered in the normal service procedures. We strongly recommend that the reader takes advantage of the information provided to prevent personal injury or injury to others.

**▲ DANGER**

**▲ WARNING**

**▲ CAUTION**

### UNDERSTAND SIGNAL WORDS

A signal word – DANGER, WARNING, or CAUTION – is used with the safety-alert symbol. DANGER identifies the most serious hazards.

DANGER or WARNING safety signs are located near specific hazards. General precautions are listed on CAUTION safety signs. CAUTION also calls attention to safety messages in this manual.



### USE COMMON SENSE WHEN HANDLING FUELS

- Transport and handle fuel only when contained in approved safety container.
- Do not smoke when refueling or during any other fuel handling operation.
- Do not refuel while the engine is running or while it is still hot.
- If fuel is spilled during refueling, wipe it off of the engine immediately and discard the rag in a safe place.
- Do not operate the equipment if fuel or oil leaks exist - repair immediately.
- Never operate this equipment in an explosive atmosphere.



- Always use the proper size grounded extension cord, conforming to the National Electric Code and Local Ordinances.
- Inspect all extensions and electrical cords for cuts, frayed wire and broken connectors before use. Do not use cords if not in good condition.
- Do not route extension cords through standing water.
- Do not operate the mixer in standing water.
- When cleaning the mixer, never spray water on the electric motor.



### HOT SURFACES

- Avoid contact with hot exhaust systems and engines.
- Allow all components in the engine compartment to cool before performing any service work.

## **WARNING**

- Never leave mixer unattended while running.
- Mix only concrete.

# HEALTH & SAFETY

## Safety Precautions

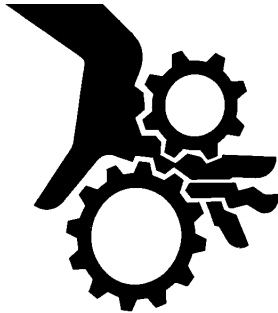

- Never perform any work on the mixer while it is running.
- Before working on the mixer, stop the engine and disconnect the spark plug wire(s) to prevent accidental starting. On electric models, disconnect the electric cord at the mixer.
- Keep cowl closed and latched during the operation, close and latch cowl immediately after starting.
- Keep hands, clothing and jewelry away from all moving parts.
- Keep all guards in place, including drum guards.
- Never place your hands or any solid object into the drum while the mixer is in operation.

---

### WEAR PROTECTIVE CLOTHING

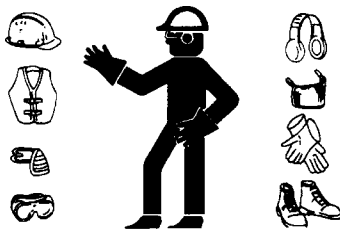

- Wear close fitting clothing and safety equipment appropriate to the job.
- Prolonged exposure to loud noise can cause impairment or loss of hearing.
- Wear a suitable hearing protective device such as earmuffs or earplugs to protect against objectionable or uncomfortable loud noises.
- Operating equipment safely requires the full attention of the operator. Do not wear radio or music headphones while operating machine.

---

### PREPARE FOR EMERGENCIES

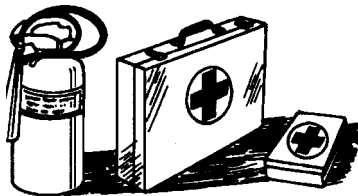

- Be prepared if a fire starts.
- Keep a first aid kit and fire extinguisher handy.
- Keep emergency numbers for doctors, ambulance service, hospital, and fire department near your telephone.

# HEALTH & SAFETY

## Safety Precautions



### Warning-Eye Protection

- Always wear splash goggles when operating mixer.



### Warning-Towing

- Warning: Do not tow the mixer with the drum in the dump position. Mixer may become unstable and tip over when hitting a curb, pothole, or other obstruction.



- Warning: Always attach safety chains properly before mixer is towed. Maximum towing speed 55 m.p.h. (90 km/hr). Reduce speed according to highway conditions.



- Starting fluid (ether) is highly flammable, do not use or an explosion or fire may result.



- Never operate unit in a poorly ventilated or enclosed area.
- Avoid prolonged breathing of exhaust gases.
- Engine exhaust fumes can cause sickness or death.

# HEALTH & SAFETY

## Safety Precautions

### PRACTICE SAFE MAINTENANCE



- Understand service procedure before doing work. Keep area clean and dry.
- Never lubricate, service or adjust machine while it is moving. Keep hands, feet, and clothing from power-driven parts. Disengage all power and operate controls to relieve pressure. Lower equipment to the ground. Stop the engine. Remove the key. Allow machine to cool.
- Securely support any machine elements that must be raised for service work.
- Keep all parts in good condition and properly installed. Repair damage immediately. Replace worn or broken parts. Remove any buildup of grease, oil, or debris.
- Disconnect battery ground cable (-) before making adjustments on electrical systems or welding on machine.

### DISPOSE OF WASTE PROPERLY

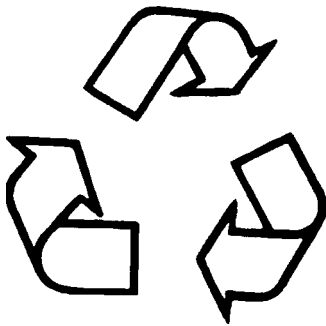

- Improperly disposing of waste can threaten the environment and ecology. Potentially harmful waste used with equipment include such items as oil, fuel, coolant, brake fluid, filters, and batteries.
- Use leakproof containers when draining fluids. Do not use food or beverage containers that may mislead someone into drinking from them.
- Do not pour waste onto the ground, down a drain, or into any water source.
- Air conditioning refrigerants escaping into the air can damage the Earth's atmosphere. Government regulations may require a certified air conditioning service center to recover and recycle used air conditioning refrigerants.
- Inquire on the proper way to recycle or dispose of waste from your local environmental or recycling center.

### SAFETY DECALS - FOR THE SAFETY OF YOURSELF AND OTHERS REPLACE ANY DAMAGED OR MISSING SAFETY DECALS.

- Warning Decal (SN-92) P/N 55011
- Safety Instruction Decal (SN-67A) P/N 55046
- Warning Decal (SN-8) P/N 55127
- Safety Chain Decal (Front Post, SN-66) P/N 55121

# OPERATION

45CM & 55CM

## BEFORE STARTING

Mixers are shipped completely assembled and ready for operation except for installation of the safety chain.

## SAFETY CHAIN INSTALLATION

Remove the safety chain kit from the engine compartment. The kit includes (1) 8 ft. length of safety chain and (2) connecting links. Pull one end of the chain through the (2) key hole slots located in the front post of the mixer with a hook (see drawing below and decal on mixer front post). Attach the connecting links to each end of the chain. Follow the instructions in the TOWING section of this manual and on the mixer front post to attach the safety chain to the towing vehicle.

### INSTALLING CHAIN TO MIXER

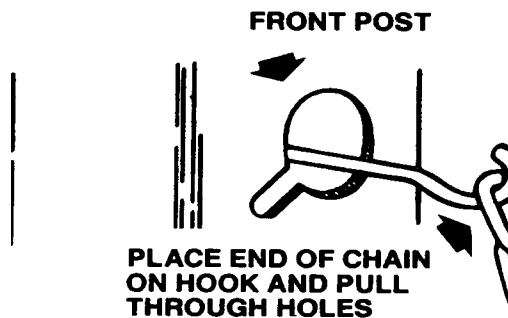

## OIL LEVELS AND LUBRICATION

Be sure to check the oil levels in the engine and engine reduction unit BEFORE starting this unit. The engine warranty is **VOID** if it is run without oil. Consult the ENGINE MANUAL supplied with this unit for specific instructions and oil recommendations.

Also check the trunnion bearings to make sure they have been greased.

## **⚠**WARNING

**BEFORE WORKING ON MACHINE, MAKE SURE ENGINE SPARK PLUG WIRE IS DISCONNECTED, OR, IF ELECTRIC, THAT THE ELECTRIC CORD IS DISCONNECTED, TO PREVENT ANY ACCIDENTAL STARTING.**

## HARDWARE

Check all hardware on mixer and engine / motor before starting. Consult the TORQUE CHART section of this manual and tighten any loose hardware accordingly.

## FUEL

If your mixer is equipped with a gasoline engine, fill the gas tank with clean gasoline from a safety can. Consult the ENGINE MANUAL supplied with this unit for the proper type of gasoline required.

**DO NOT** mix oil with gasoline.

## **⚠**WARNING

**FOLLOW THE GUIDELINES FOUND IN THE SAFETY PRECAUTION SECTION OF THIS MANUAL WHENEVER HANDLING GASOLINE.**

## TO START THE ENGINE / MOTOR

**COLD START** - Open the fuel valve under the gas tank all the way. Open the throttle approximately half way and apply the choke. Pull the starter rope sharply until the engine starts. When the engine starts, open the choke and adjust the throttle as necessary to keep it running. Allow the engine to warm up for a few minutes before placing it under the load. If the engine doesn't start after (3) pulls, open choke slightly to prevent flooding. Always operate the engine at full throttle when under load.

**HOT START** - Open the valve under the gas tank all the way if it has been shut off. Open the throttle approximately half way. Do not apply the choke. Pull the starter rope sharply until the engine starts. When the engine starts, adjust the throttle. Always operate

# OPERATION

45CM & 55CM

the engine at full throttle when under load. Adjust engine speed so drum is turning between 20 - 25 RPM.

**NOTE:** These starting instructions are general guidelines only. Since many engine options are available on the manufacturer's CM mixers, consult the ENGINE MANUAL included with this unit for specific instructions.

**ELECTRIC MOTORS** - Use the proper size (3) wire (grounded) extension cord, conforming to the National Electric Code and Local Ordinances. DO NOT use (2) wire extension cord. Check any extension cord carefully for broken connectors, bare wires and damaged insulation. DO NOT use any cord found to be in poor condition. Make sure the extension cord is not routed through standing water and that all the connections are tight. Use the shortest extension cord possible. Turn motor on.

## TO STOP THE ENGINE / MOTOR

**GASOLINE ENGINES** - Depress grounding switch located on the left cowl side and hold down until engine stops completely. Consult the ENGINE MANUAL included with this unit for specific instructions. If the mixer is to be left unattended for any length of time, close the fuel valve under the gas tank.

**ELECTRIC MOTORS** - Turn the motor off. If the mixer is to be left unattended for any length of time, disconnect the power cord.

## OPERATION

Start the engine / motor as previously instructed and allow gasoline engines to reach operating temperatures. Close the engine cowl. NEVER operate the mixer with cowl open.

With drum operating between 20 - 25 RPM's the mixer is now ready for the addition of the concrete mix. For best results proceed as follows:

1. Pour the required amount of water into drum.

2. Add the required amount of gravel.
3. Add the required amount of cement.
4. Add the required amount of sand. By adding the water and gravel first the drum will be kept clean and a good tumbling action will be maintained when cement and sand will be added.

To discharge concrete, grab the drum handle firmly and push it towards the drum to disengage. Dump drum in desired direction. After discharge of concrete return the drum to the desired position. To prevent accidental discharge, make sure the dump handle lock pin is firmly seated into tilt disc mounted on the frame. Immediately pour in the required amount of water for the next batch, this will clean the drum and paddles between batches.

## GENERAL MIXING INSTRUCTIONS

The total volume is 6.2 / 6.7 cubic ft. The maximum batch size is 4 / 5 cubic ft. depending on the type of mix being used. A smaller batch size may be required to give a uniformly mixed batch.

## SAMPLE MIX

Volume relationship of 1:2 - 1/2:3 (cement : sand : gravel) mix. The mix volume may vary depending on aggregate used.

Mix Volume Cu. Ft.	2	3	4	5
Cement (bags)	1/3	1/2	2/3	7/8
Water (gal.)	1-3/4	2-1/2	3-1/2	4-3/4
Sand (gal./ shovels)	6	9	12	15
Gravel (gal./ shovels)	8	12	16	20

# OPERATION

45CM & 55CM

## CLEANING

For consistent performance, long life and continued high quality mixing of cement, thoroughly clean the mixer inside and out at the end of each day's operation. Drum may be scoured by 2 minute operation with gravel and water mixture. Discharge, then hose down drum inside and outside. Keep mixer clean.

Before cleaning, shut off the engine or motor and disconnect the spark plug wire or electric cord to prevent accidental starting. Spray the mixer with water before the mix dries to remove any accumulations. Dried mix should be scraped out as necessary. **DO NOT** beat on drum with shovel, hammer or other device to break up accumulations of dried mix, as this will dent and damage the drum.

## **⚠️ WARNING**

**NEVER POUR OR SPRAY WATER ON THE ENGINE OR MOTOR.**

**NEVER PUT HANDS OR ANY OBJECT INTO THE DRUM WHILE THE ENGINE OR MOTOR IS RUNNING.**

**ALWAYS DISCONNECT THE SPARK PLUG WIRE OR ELECTRIC CORD WHEN CLEANING INSIDE DRUM.**

## TOWING

Before attempting to tow this mixer, check the state and local laws that apply to your intended route and check the following:

1. Hitch attached to the towing vehicle securely.
2. Towpole fully extended and bolted to mixer securely.
3. Safety chain hooked up properly (see illustration or decal on mixer front post).

## INSTALLING CHAIN TO VEHICLE

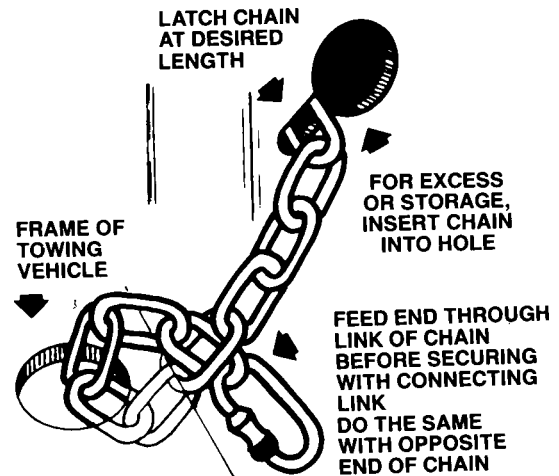

4. Lug nuts, wheel nuts and axle mount nuts tight.
5. Drum rotated straight down, dump handle lock pin firmly seated into the tilt disc.
6. Tires in good shape and at proper inflation as follows:

Tire size 4.80 x 8 @ 60 P.S.I.

Refer to FRAME, DRUM, AND ENGINE ASSEMBLY section of the Service/Parts Manual for parts identification and location.

## **⚠️ WARNING**

**DO NOT EXCEED A TOWING SPEED OF 55 MILES/HR (90 KM/HR). FOR POOR ROAD CONDITIONS OR INCLEMENT WEATHER, REDUCE SPEED ACCORDINGLY.**

# MAINTENANCE SCHEDULE

45CM & 55CM

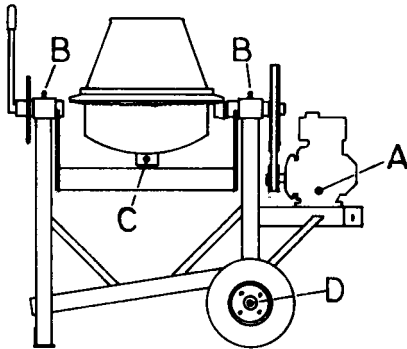

**NOTE:** Cowl removed for clarity.  
Do not operate mixer with cowl removed.

**A. ENGINE** - Daily check the oil levels in the engine and engine reduction unit. The engine warranty is **VOID** if run without oil. Since there are many options available on this mixer, consult the **ENGINE MANUAL** for specific recommendation as to oil level, oil type required and frequency of oil changes required. For maximum service life from the engine, follow those recommendations.

**B. WEEKLY** - Grease trunnions (2) places.

**C. MONTHLY** - Grease drum spindle through grease fitting (1) place.

**YEARLY** - Disassemble drum and drum spindle and clean and repack drum spindle bearings as follows - Remove plug from inside drum. Remove the cotter key and castle nut from the drum spindle and slide the drum off the spindle.

Remove the drum bearings, clean thoroughly and repack with grease. Clean spindle and drum bearing housing and coat with grease inside. Reassemble the drum and bearings to the drum spindle and install the castle nut to hold in place. Tighten castle nut snugly to seat bearings, then back off to the nearest slot which aligns with the hole in the spindle shaft, then install cotter key. Turn drum and check that it turns freely. Install plug and tighten securely. **Note:** **DO NOT** allow any sand, cement or other foreign matter to fall into the bearing housing during reassembly.

**D. YEARLY** - Disassemble the wheel hubs and clean and repack the wheel bearings with grease. Reassemble the hubs using new wheel seals. Tighten castle nuts snugly then back off to the 1st slot that aligns with the hole in the axle spindle. Install cotter key and spin hubs to check for binding or excessive slop. Reinstall dust cap and tires. **DO NOT** lubricate pinion and ring gear. They will collect abrasive materials and accelerate wear.

Use any Grade #1 lithium base grease for the above applications.

## BELT TENSION

**WEEKLY** - Check drive belt for proper tension and excessive wear. Replace worn belt or adjust belt tension as required. To remove and adjust belt, loosen (do not remove) motor base mounting bolt, lift up on motor base, and remove belt. Install new belt and push motor base down until proper belt tension is achieved. Tighten motor base mounting bolt. Proper belt tension is achieved when belt deflection is 1/2 inch to 3/4 inch midway between drive sheaves.



**CALIFORNIA PROPOSITION 65 WARNING: Engine exhaust from this product contains chemicals known to the State of California to cause cancer, birth defects, or other reproductive harm.**



Stone Construction Equipment, Inc.  
P.O. Box 150, Honeoye, New York 14471  
Phone: (800) 888-9926  
Fax: 716-229-2363  
e-mail: [sceny@mcimail.com](mailto:sceny@mcimail.com)  
www: [stone-equip.com](http://stone-equip.com)

A 100% employee-owned American manufacturer

© 1995 Stone Construction Equipment, Inc.  
Printed in U.S.A.

GP1M