



OPERATOR MANUAL

MODELS: 855PMP



PLASTIC DRUM CHAMPION® PLASTER/MORTAR MIXER

A 100% employee-owned American manufacturer

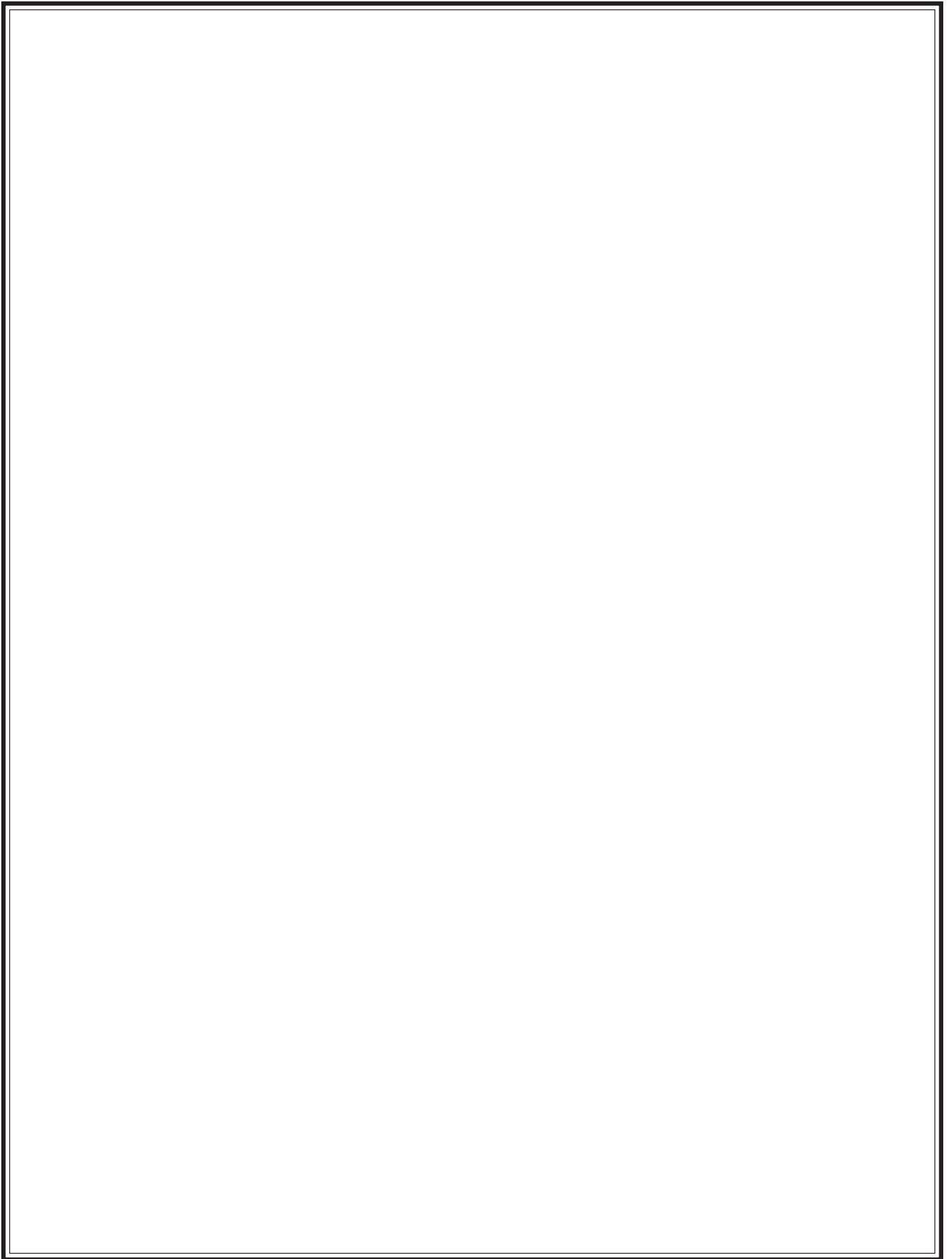

TABLE of CONTENTS

855PMP

FOREWORD	4
LIMITED WARRANTY	5
TECHNICAL DATA	6 -8
Specifications	6
Imperial Torque Chart	7
Metric Torque Chart	8
HEALTH & SAFETY	9 - 13
OPERATION	14-18
Location and Use of Controls	14
Operating Features/Patented Automatic Guard Lifter/Quadruple Shaft Seal/Axle	15
Before Starting/Read Owners Manual/Safety Chain Installation/Dump Handle Installation	15
Oil Levels and Lubrication/Axle Blocks/Rubber Blades/Hardware/Fuel	15
To Start/Disengage Drive Train/Check Drum Dump Latch	16
Start the Engine/Motor	16
Gasoline Engine/Cold Start/Hot Start	16
Electric Motors/Electric Motor Switch	16
Stop the Engine/Motor/Gasoline Engines/Electric Motors	16
Operation/Cleaning	17
Warnings	18
MAINTENANCE	19-
Cleaning/Lubrication/Hardware/Towing	19-20
Bull Gear Assembly	20
Maintenance Schedule	21
Maintenance Chart	22
CALIFORNIA PROPOSITION 65 WARNING	IBC

**MANUFACTURED UNDER ONE OR MORE OF THE FOLLOWING PATENTS AND OTHERS
PENDING: 3761058, 3905519, 3931748, 3932006, 4043540, 4180281.**

User Information

Foreword

These instructions include:

- Safety regulations
- Operating instructions
- Maintenance instructions

These instructions have been prepared for operation on the construction site and for the maintenance engineer.

These instructions are intended to simplify operation of the machine and to avoid malfunctions through improper operation.

Observing the maintenance instructions will increase the reliability and service life of the machine when used on the construction site and reduce repair costs and downtimes.

Always keep these instructions at the place of use of the machine.

Only operate the machine as instructed and follow these instructions.

Observe the safety regulations as well as the guidelines of the civil engineering trade association. Observe the safety rules for operation and the pertinent regulations for the prevention of accidents.

Stone Construction Equipment, Inc. is not liable for the function of the machine when used in an improper manner or for other than the intended purpose.

Operating errors, improper maintenance and the use of incorrect operating materials are not covered by the warranty.

The above information does not extend the warranty and liability conditions of business of Stone Construction Equipment, Inc.

1. Machine Type: _____

Machine S/N: _____

2. Engine Type: _____

Engine S/N: _____

3. VIN: _____

4. Purchase Date: _____

5. Dealer/Distributor Information:

Name: _____

Address: _____

Phone #: _____

Fax #: _____

6. Battery Manufacturer: _____

Battery Type: _____

Battery S/N: _____

Location of above information:

1. Information on S/N tag.
2. Information on engine tag.
3. Information on S/N tag - if applicable.
4. Date you purchased machine.
5. Dealer machine was purchased from.
6. Information on battery and battery warranty card.

Stone Construction Equipment, Inc.
P.O. Box 150, Honeoye, New York 14471
Phone: (800) 888-9926
Fax: (716) 229-2363

Limited Warranty

The Manufacturer warrants that products manufactured shall be free from defects in material and workmanship that develop under normal use for a period of 90 days for concrete vibrators and electric pumps, one year for Rhino®, Bulldog®, Wolfpac Rollers™, trowels, Stompers®, saws, forward plates, engine powered pumps, and 6 months for all other products from the date of shipment. The foregoing shall be the exclusive remedy of the buyer and the exclusive liability of the Manufacturer. Our warranty excludes normal replaceable wear items, i.e. gaskets, wear plates, seals, O-rings, V-belts, drive chains, clutches, etc. Any equipment, part or product which is furnished by the Manufacturer but manufactured by another, bears only the warranty given by such other manufacturer. (The Manufacturer extends the warranty period to "Lifetime" for the drum bearings and seals for the mortar mixers, and agrees to furnish, free of charge, the bearings and seals only upon receipt of the defective parts. The warranty is two years for eccentric bearings on the forward plate compactors, mortar and plaster mixer drums, trowel gearboxes and five years on the Bulldog trench roller eccentric bearings.) A Warranty Evaluation Form must accompany all defective parts. Warranty is voided by product abuse, alterations, and use of equipment in applications for which it was not intended, use of non-manufacturer parts, or failure to follow documented service instructions. The foregoing warranty is exclusive of all other warranties whether written or oral, expressed or implied. No warranty of merchantability or fitness for a particular purpose shall apply. The agents, dealer and employees of Manufacturer are not authorized to make modification to this warranty, or additional warranties binding on Manufacturer. Therefore, additional statements, whether oral or written, do not constitute warranty and should not be relied upon.

The Manufacturer's sole responsibility for any breach of the foregoing provision of this contract, with respect to any product or part not conforming to the Warranty or the description herein contained, is at its option (a) to repair, replace or refund such product or parts upon the prepaid return thereof to location designated specifically by the Manufacturer. Product returns not shipped prepaid or on an economical transportation basis will be refused (b) as an alternative to the foregoing modes of settlement - the Manufacturer's dealer to repair defective units with reimbursement for expenses, except labor, and be reviewed with the Manufacturer prior to repair. A Warranty Evaluation Form must accompany all warranty claims.

Except as set forth hereinabove and without limitation of the above, there are no warranties or other affirmations which extends beyond the description of the products and the fact hereof, or as to operational efficiency, product reliability or maintainability or compatibility with products furnished by others. In no event whether as a result of breach of contract or warranty or alleged negligence, shall the Manufacturer be liable for special or consequential damages including but not limited to: Loss of profits or revenues, loss of use of the product or any associated product, cost of capital, cost of substitute products, facilities or services or claims of customers.

No claim will be allowed for products lost or damaged in transit. Such claims should be filed with the carrier within fifteen days.

Effective April 1, 1998.



Stone Construction Equipment, Inc.
32 East Main Street, P. O. Box 150
Honeoye, NY 14471-0150

Phone: 1-800-888-9926 • 1-716-229-5141

Fax: 1-716-229-2363

www.stone-equip.com • e-mail: sceny@mcimail.com

TECHNICAL DATA

Specifications

Stone 855PMP Mixer – Specifications

<u>Dimensions</u> Operating Wt.	605 lbs. / 275 kg
Batch Capacity (Bags)	2 1/2 - 3 bags
Batch Capacity (cu. ft.)	8 cu. ft. / .23 cu. m.
Total Volume	9.0 cu. ft. / .25 cu. m.
L x W x H	76 x 34 x 54 (in.) / 193 x 86 x 137 (cm.)
Engine	2 hp Electric / 1.5 kW 8 hp B&S / 6.0 kW 8 hp B&S I/P / 6.0 kW 8.5 hp Robin / 6.3 kW 8 hp Honda / 6.0 kW 8 hp B&S 6.0 kW 10 hp B&S I/C / 7.5 kW

TECHNICAL DATA

Imperial Torque Chart

SAE GRADE 5 Coarse Thread

SIZE	PLATED	
1/4 – 20 (.250)	6 ft. lbs.	8 Nm
5/16 – 18 (.3125)	13 ft. lbs.	18 Nm
3/8 – 16 (.375)	23 ft. lbs.	31 Nm
7/16 – 14 (.4375)	37 ft. lbs.	50 Nm
1/2 – 13 (.500)	57 ft. lbs.	77 Nm
9/16 – 12 (.5625)	82 ft. lbs.	111 Nm
5/8 – 11 (.625)	112 ft. lbs.	152 Nm
3/4 – 10 (.750)	200 ft. lbs.	271 Nm
7/8 – 9 (.875)	322 ft. lbs.	436.5 Nm
1 – 8 (1.000)	483 ft. lbs.	655 Nm

SAE GRADE 8 Coarse Thread

SIZE	PLATED	
1/4 – 20 (.250)	9 ft. lbs.	12 Nm
5/16 – 18 (.3125)	18 ft. lbs.	24 Nm
3/8 – 16 (.375)	33 ft. lbs.	45 Nm
7/16 – 14 (.4375)	52 ft. lbs.	70 Nm
1/2 – 13 (.500)	80 ft. lbs.	108 Nm
9/16 – 12 (.5625)	115 ft. lbs.	156 Nm
5/8 – 11 (.625)	159 ft. lbs.	215 Nm
3/4 – 10 (.750)	282 ft. lbs.	382 Nm
7/8 – 9 (.875)	454 ft. lbs.	615 Nm
1 – 8 (1.000)	682 ft. lbs.	925 Nm

SAE GRADE 5 Fine Thread

SIZE	PLATED	
1/4 – 28 (.250)	7 ft. lbs.	10Nm
5/16 – 24 (.3125)	14 ft. lbs.	19 Nm
3/8 – 24 (.375)	26 ft. lbs.	35 Nm
7/16 – 20 (.4375)	41 ft. lbs.	56 Nm
1/2 – 20 (.500)	64 ft. lbs.	87 Nm
9/16 – 18 (.5625)	91 ft. lbs.	123 Nm
5/8 – 18 (.625)	128 ft. lbs.	173 Nm
3/4 – 16 (.750)	223 ft. lbs.	302 Nm
7/8 – 14 (.875)	355 ft. lbs.	481 Nm
1 – 12 (1.000)	529 ft. lbs.	717 Nm
1 – 14 (1.000)	541 ft. lbs.	733 Nm

SAE GRADE 8 Fine Thread

SIZE	PLATED	
1/4 – 28 (.250)	10 ft. lbs.	14Nm
5/16 – 24 (.3125)	20 ft. lbs.	27 Nm
3/8 – 24 (.375)	37 ft. lbs.	50 Nm
7/16 – 20 (.4375)	58 ft. lbs.	79 Nm
1/2 – 20 (.500)	90 ft. lbs.	122 Nm
9/16 – 18 (.5625)	129 ft. lbs.	175 Nm
5/8 – 18 (.625)	180 ft. lbs.	244 Nm
3/4 – 16 (.750)	315 ft. lbs.	427 Nm
7/8 – 9 (.875)	501 ft. lbs.	679 Nm
1 – 12 (1.000)	746 ft. lbs.	1011 Nm
1 – 14 (1.000)	764 ft. lbs.	1036 Nm

TECHNICAL DATA

Metric Torque Chart

Property Class 8.8

ZINC-PLATED

SIZE	Coarse Thread		Fine Thread	
	Nm	ft. lbs.	Nm	ft. lbs.
M6	9.9	7	10	7
M8	24	18	25	18
M10	48	35	49	36
M12	83	61	88	65
M14	132	97	140	103
M16	200	148	210	155
M20	390	288	425	313
M24	675	498	720	531

Property Class 10.9

ZINC-PLATED

SIZE	Coarse Thread		Fine Thread	
	Nm	ft. lbs.	Nm	ft. lbs.
M6	14	10	14	10
M8	34	25	35	26
M10	67	49	68	50
M12	117	86	125	92
M14	185	136	192	142
M16	285	210	295	218
M20	550	406	600	443
M24	950	701	1000	738

Property Class 12.9

ZINC-PLATED

SIZE	Coarse Thread		Fine Thread	
	Nm	ft. lbs.	Nm	ft. lbs.
M6	16.5	12	16.5	12
M8	40	30	42	31
M10	81	60	82	60
M12	140	103	150	111
M14	220	162	235	173
M16	340	251	350	258
M20	660	487	720	531
M24	1140	841	1200	885

Conversion Factor: 1 ft. lb. = 1.3558 Nm

HEALTH & SAFETY

Safety Precautions

Before using this equipment, study this entire manual to become familiar with its operation. Do not allow untrained or unauthorized personnel, especially children, to operate this equipment. Use only factory authorized parts for service.

When warning decals are destroyed or missing, contact the Manufacturer immediately at 1-800-888-9926 for replacement. For the safety of yourself and others, it is imperative that the following rules are observed. Failure to do so may result in serious injury or death.

FOLLOW SAFETY INSTRUCTIONS

Carefully read all safety messages and decals in this manual and on your machine safety signs. Keep decals in good condition. Replace missing or damaged decals. Be sure new equipment components and repair parts include the current safety signs. Replacement safety signs and decals are available through your dealer.

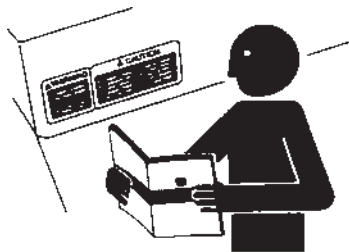

Learn how to operate the machine and how to use controls properly. Do not let anyone operate without instruction.

Keep your machine in proper working condition. Unauthorized modifications to the machine may impair the function and/or safety and affect machine life.

If you do not understand any part of this manual and need assistance, contact your dealer.

▲ DANGER

▲ WARNING

▲ CAUTION

UNDERSTAND SIGNAL WORDS

A signal word – DANGER, WARNING, or CAUTION – is used with the safety-alert symbol. DANGER identifies the most serious hazards.

DANGER or WARNING safety signs are located near specific hazards. General precautions are listed on CAUTION safety signs. CAUTION also calls attention to safety messages in this manual.



This notation appears before warnings in the text. It means that the step which follows must be carried out to avoid the possibility of personal injury or death. These warnings are intended to help the technician avoid any potential hazards encountered in the normal service procedures. We strongly recommend that the reader takes advantage of the information provided to prevent personal injury or injury to others.

HEALTH & SAFETY

Safety Precautions

USE COMMON SENSE WHEN HANDLING FUELS



- Transport and handle fuel only when contained in approved safety container.
- Do not smoke when refueling or during any other fuel handling operation.
- Do not refuel while the engine is running or while it is still hot.
- If fuel is spilled during refueling, wipe it off from the engine immediately and discard the rag in a safe place.
- Do not operate the equipment if fuel or oil leaks exist - repair immediately.
- Never operate this equipment in an explosive atmosphere.



- Always use the proper size grounded extension cord, conforming to the National Electric Code and Local Ordinances.
- Inspect all extensions and electrical cords for cuts, frayed wire and broken connectors before use. Do not use cords if not in good condition.
- Do not route extension cords through standing water.
- Do not operate the mixer in standing water.
- When cleaning the mixer, never spray water over the motor.



HOT SURFACES

- Avoid contact with hot exhaust systems and engines.
- Allow all components in the engine compartment to cool before performing any service work.

WARNING

- Never leave mixer unattended while running.
- Mix only Motor, Plaster, Terrazzo, Fireproofing and Grout.
- Do Not operate machine if rocks, stones, ice or frozen materials are in mix and/or in drum of mixer. The machine could jam, causing damage to the equipment or injury to the operator.

HEALTH & SAFETY

Safety Precautions

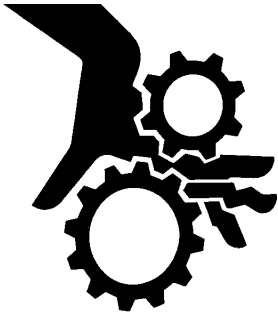

- Never perform any work on the mixer while it is running.
- Before working on the mixer, stop the engine and disconnect the spark plug wire(s) to prevent accidental starting. On electric models, disconnect the electric cord at the mixer.
- Keep cowl closed during the operation, close cowl immediately after starting.
- Keep hands, clothing and jewelry away from all moving parts.
- Keep all guards in place, including drum guards.
- Never stick your hands or any solid object into the drum while the mixer is in operation.

WEAR PROTECTIVE CLOTHING



- Wear close fitting clothing and safety equipment appropriate to the job.
- Prolonged exposure to loud noise can cause impairment or loss of hearing.
- Wear a suitable hearing protective device such as earmuffs or earplugs to protect against objectionable or uncomfortable loud noises.
- Operating equipment safely requires the full attention of the operator. Do not wear radio or music headphones while operating machine.

PREPARE FOR EMERGENCIES

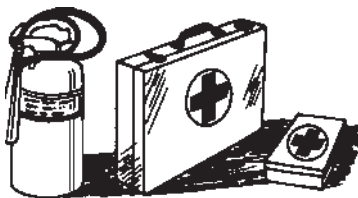

- Be prepared if a fire starts.
- Keep a first aid kit and fire extinguisher handy.
- Keep emergency numbers for doctors, ambulance service, hospital, and fire department near your telephone.

HEALTH & SAFETY

Safety Precautions



Warning-Eye Protection

- Always wear splash goggles when operating mixer.
-

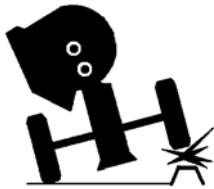

Warning-Towing

- Warning: Do not tow the mixer with the drum in the dump position. Mixer may become unstable and tip over when hitting a curb, pothole, or other obstruction.



- Warning: Always properly attach safety chains before mixer is towed. Maximum towing speed 55 m.p.h. (90 km/hr). Reduce speed according to highway conditions.
-



- Starting fluid (ether) is highly flammable, do not use or an explosion or fire may result.
-



- Never operate unit in a poorly ventilated or enclosed area.
- Avoid prolonged breathing of exhaust gases.
- Engine exhaust fumes can cause sickness or death.

HEALTH & SAFETY

Safety Precautions



PRACTICE SAFE MAINTENANCE

- Understand service procedure before doing work. Keep area clean and dry.
- Never lubricate, service or adjust machine while it is moving. Keep hands, feet, and clothing from power-driven parts. Disengage all power and operate controls to relieve pressure. Lower equipment to the ground. Stop the engine. Remove the key. Allow machine to cool.
- Securely support any machine elements that must be raised for service work.
- Keep all parts in good condition and properly installed. Fix damage immediately. Replace worn or broken parts. Remove any buildup of grease, oil, or debris.
- Disconnect battery ground cable (-) before making adjustments on electrical systems or welding on machine.

DISPOSE OF WASTE PROPERLY

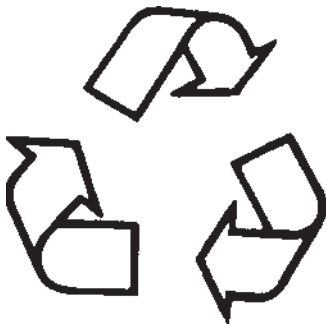

- Improperly disposing of waste can threaten the environment and ecology. Potentially harmful waste used with equipment include such items as oil, fuel, coolant, brake fluid, filters, and batteries.
- Use leakproof containers when draining fluids. Do not use food or beverage containers that may mislead someone into drinking from them.
- Do not pour waste onto the ground, down a drain, or into any water source.
- Air conditioning refrigerants escaping into the air can damage the Earth's atmosphere. Government regulations may require a certified air conditioning service center to recover and recycle used air conditioning refrigerants.
- Inquire on the proper way to recycle or dispose of waste from your local environmental or recycling center.

SAFETY DECALS - FOR THE SAFETY OF YOURSELF AND OTHERS REPLACE ANY DAMAGED OR MISSING SAFETY DECALS.

- Warning Decal (SN-91) P/N 55010
- Warning Decal (SN-92) P/N 55011
- Safety Instruction Decal (SN-67A) P/N 55013
- Warning Decal (SN-8) P/N 55014
- Safety Chain Decal (Front Post, SN-66) P/N 55121

OPERATION

Location and Use of Controls

Before operating this unit, it is important to familiarize yourself, and any other personnel who will be using it, with the location and proper use of the controls to insure safe and efficient operation.

- A. Always make sure that the drum latch is in the lock position (down) before starting machine. With engine running, turn clutch lever to the right to turn paddles or to the left to stop.



- B. To dump mix from drum, stop paddles, move drum latch up and pull dump handle down. Always use caution when dumping mix.

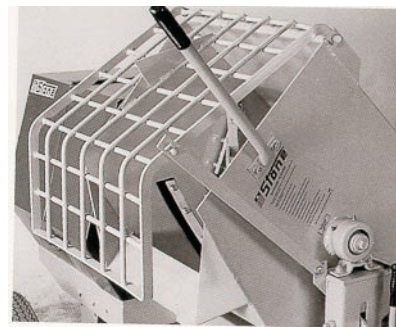

- C. Always grease drum seals (at both ends) as recommended in the maintenance chart. The grease purges dirt, prolonging bearing life.



- D. Always keep drum and paddles clean. Never run machine with hardened mix or foreign objects in drum. Doing so damages paddles and/or engine.

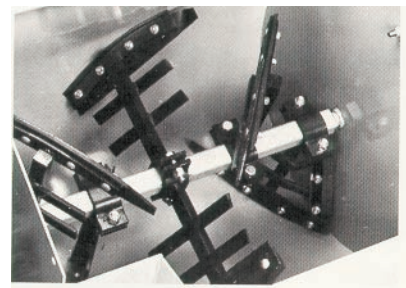

OPERATION

Operating Features Location and Use of Controls

OPERATING FEATURES

Your new 855 plastic drum plaster/mortar mixer comes standard with the following features:

PATENTED AUTOMATIC GUARD LIFTER

Lifts the drum guard as the drum is tilted to prevent the mix from being poured through the guard and causing a building up on it. The guard and guard lifter system is designed for your safety and convenience, please **DO NOT** operate the mixer with the guard lifter disconnected or the guards removed.

QUADRUPLE SHAFT SEAL

Provides a life long neoprene and urethane seal system that completely isolates the sealed ball bearings in the drum trunnions from the mix.

EXTENDIBLE AXLE

Collapses to less than 36 inches total width for ease in maneuvering mixer around the work site or to save space while the mixer is in storage, extends to 46 inches total width to provide stability and safety when towing the mixer.

BEFORE STARTING

READ ENGINE OWNERS MANUAL.

Mixers are shipped completely assembled and ready for operation except for installation of the safety chain.

SAFETY CHAIN INSTALLATION

Remove the safety chain kit from the engine compartment. The kit includes (1) 12 ft. length of safety chain and (2) connecting links. Pull one end of the chain through the (2) key hole slots located in the front post of the mixer with a hook (see drawing below and decal on mixer front post). Attach the connecting links to each end of the chain. Follow the instructions in the TOWING section of this

manual and on the mixer front post to attach the safety chain to the towing vehicle.

INSTALLING CHAIN TO MIXER

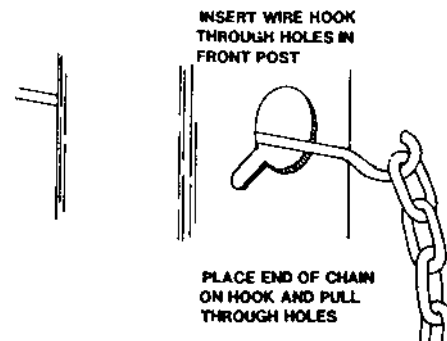

DUMP HANDLE INSTALLATION

Remove the dump handle from the mixer drum where it is attached to the paddle shaft. Consult the **FRAME AND DRUM ASSEMBLY** section of this manual and use the (2) 3/8 bolts and nuts provided near the top, tow pole end of the drum to install the drum handle as shown in the exploded view. Do not torque bolt that holds the guard - see note in the **TORQUE CHART** section of this manual.

OIL LEVELS AND LUBRICATION

Be sure to check the oil levels in the engine and engine reduction unit **BEFORE** starting this unit. The engine warranty is **VOID** if it is run without oil. Consult the **ENGINE MANUAL** supplied with this unit for specific instructions and oil recommendations.

AXLE BLOCKS (SPRING AXLE OPTION ONLY)

Before your mixer was shipped, wood blocks were placed in the axle springs to avoid bouncing during transport. Before operation, loosen spring bolts, remove blocks and retighten spring bolts until locknut is fully engaged.

OPERATION

Hardware/Drive Train/Start the Engine/Motor

RUBBER BLADES

The rubber blades are factory pre-set. Due to local preferences, some readjustment may be desired. On the 855PMP the blades will never rub on the side of the drum.

WARNING

BEFORE WORKING ON MACHINE, MAKE SURE ENGINE SPARK PLUG WIRE IS DISCONNECTED, OR, IF ELECTRIC, THAT THE ELECTRIC CORD IS DISCONNECTED, TO PREVENT ANY ACCIDENTAL STARTING.

HARDWARE

Check all hardware on mixer and engine / motor before starting. Consult the TORQUE CHART section of this manual and tighten any loose hardware accordingly.

FUEL

If your mixer is equipped with a gasoline engine, fill the gas tank with clean gasoline from a safety can. Consult the ENGINE MANUAL supplied with this unit for the proper type of gasoline required.

DO NOT mix oil with gasoline.

WARNING

FOLLOW THE GUIDELINES FOUND IN THE SAFETY PRECAUTION SECTION OF THIS MANUAL WHENEVER HANDLING GASOLINE.

TO START

DISENGAGE DRIVE TRAIN

Move clutch lever located at front of mixer to the UP position (lever parallel to front post).

CHECK DRUM DUMP LATCH

Make sure that the drum latch is engaged with the drum in the upright or mixing position.

START THE ENGINE/MOTOR

GASOLINE ENGINE

COLD START - Open the fuel valve under the gas tank all the way. Open the throttle approximately half way and apply the choke. Pull the starter rope sharply about (3) times. When the engine starts, open the choke and adjust the throttle as necessary to keep it running. Allow the engine to warm up for a few minutes before placing it under the load. If the engine doesn't start after (3) pulls, open choke slightly to prevent flooding. Always operate the engine at full throttle when under load.

HOT START - Open the valve under the gas tank all the way if it has been shut off. Open the throttle approximately half way. Do not apply the choke. Pull the starter rope sharply until the engine starts. When the engine starts, adjust the throttle. Always operate the engine at full throttle when under load.

NOTE: These starting instructions are general guidelines only. Since many engine Options are available on the manufacturer's PMP mixers, consult the ENGINE MANUAL included with this unit for specific instructions.

ELECTRIC MOTORS - Use the proper size (3) wire (grounded) extension cord, conforming to the National Electric Code and Local Ordinances. **DO NOT** use (2) wire extension cord. Check any extension cord which you plan on using carefully for broken connectors, bare wires and damaged insulation. **DO NOT** use any cord found to be in poor condition. Make sure the extension cord is not routed through standing water and that all the connections are tight. Use the shortest extension cord possible. Turn motor on.

OPERATION

ELECTRIC MOTOR SWITCH - Located on the motor. It is used to start and stop the electric mixer.

TO STOP THE ENGINE / MOTOR

GASOLINE ENGINES - Depress kill switch located on stationary cowl half and hold down until engine stops completely. To improve the engine service life, move the clutch lever to the UP position to disengage the drive train and allow the engine to idle without load for (2) to (5) minutes before shutting it down. When the idling period is up, use the grounding clip, kill switch, or oil minder switch to stop the engine. Consult the ENGINE MANUAL included with this unit for specific instructions. **IF THE MIXER IS TO BE LEFT UNATTENDED FOR ANY LENGTH OF TIME, CLOSE THE FUEL VALVE UNDER THE GAS TANK.**

ELECTRIC MOTORS - Disengage the drive train by moving the clutch lever to the UP position.

WARNING

TURN THE MOTOR OFF. IF THE MIXER IS TO BE LEFT UNATTENDED FOR ANY LENGTH OF TIME, DISCONNECT THE POWER CORD.

OPERATION

Start the engine / motor as instructed above and allow gasoline engines to reach operating temperatures. Close the engine cowl. **NEVER** operate the mixer with cowl open. **NEVER** operate the mixer with the drum guard open or removed. Move the clutch lever clockwise to the DOWN position to engage the drive train and set mixer paddles in motion.

The mixer is now ready for the addition of the mortar mix. For best results proceed as follows:

1. Pour half the required amount of water into drum.

To Stop/Operation/Cleaning

2. Add half the required amount of sand.
3. Add the total required amount of mortar mix (cement, lime, etc.).
4. Add the balance of sand and water.

After mixing for the proper length of time (homogeneous mix obtained), discharge the mix from the drum by using the dump handle to dump the drum and control the discharge.

After discharge, if another batch of mortar is to be mixed, return the drum to the mixing position and make sure the drum latch is engaged. Immediately pour in half of the required water for the next batch with paddles turning. This will clean the paddles and drum between batches and help prevent lumps of dried mortar from forming and contaminating the next batch.

If no more mortar is to be mixed in the next hour or so, the mixer drum and paddle should be thoroughly cleaned. If no more mortar is to be mixed that day, the entire mixer should be thoroughly cleaned inside and outside to insure maximum life and performance.

CLEANING

For consistent performance, long life and continued high quality mixing of plaster or mortar, thoroughly clean the mixer inside and out at the end of each day's operation. To prevent lumps of dried plaster from forming and contaminating future batches of plaster or mortar, do not allow build up materials to form on drum guards, around paddles or anywhere inside the drum.

Before cleaning, shut the engine or motor and disconnect the spark plug wire or electric cord to prevent accidental starting. Spray the mixer with water before the mix dries to remove any accumulations. Dried mix should be scraped out as necessary. **DO NOT** beat on the drum with a shovel, hammer or other device to break up accumulations of dried mix, as this will dent and damage the drum.

WARNING

NEVER POUR OR SPRAY WATER OVER THE ENGINE OR MOTOR.

NEVER PUT HANDS OR ANY OBJECT INTO THE DRUM WHILE THE ENGINE OR MOTOR IS RUNNING.

ALWAYS DISCONNECT THE SPARK PLUG WIRE OR ELECTRIC CORD WHEN CLEANING INSIDE DRUM.

ALWAYS MAKE SURE GUARD LIFTER IS RECONNECTED TO GUARD BEFORE USING MIXER, DO NOT OPERATE THE MIXER WITH DRUM GUARD OPEN OR REMOVED.

MAINTENANCE

Cleaning/Lubrication/ Hardware/Towing

CLEANING

For consistent performance, long life and continued high quality mixing of plaster or mortar, thoroughly clean the mixer inside and out at the end of each day's operation. To prevent lumps of dried plaster from forming and contaminating future batches of plaster or mortar, do not allow build up materials to form on drum guards, around paddles or anywhere inside the drum.

Before cleaning, shut the engine or motor and disconnect the spark plug wire or electric cord to prevent accidental starting. Spray the mixer with water before the mix dries to remove any accumulations. Dried mix should be scraped out as necessary. **DO NOT** beat on the drum with a shovel, hammer or other device to break up accumulations of dried mix, as this will dent and damage the drum.

WARNING

NEVER POUR OR SPRAY WATER OVER THE ENGINE OR MOTOR.

NEVER PUT HANDS OR ANY OBJECT INTO THE DRUM WHILE THE ENGINE OR MOTOR IS RUNNING.

ALWAYS DISCONNECT THE SPARK PLUG WIRE OR ELECTRIC CORD WHEN CLEANING INSIDE DRUM.

ALWAYS MAKE SURE GUARD LIFTER IS RECONNECTED TO GUARD BEFORE USING MIXER, DO NOT OPERATE THE MIXER WITH DRUM GUARD OPEN OR REMOVED. WHEEL BEARING

LUBRICATION

Fill wheel hub with grease to inside diameter of outer races and also fill hub grease cap. Never use grease heavier than 265 A.S.T.M. penetration (No. 2 grade). Grease bearing cone by machine or by hand method. Force grease between rollers, cone and cage. (If Ball Bearing Hub: force grease between balls.) It is not recommended that a pressure grease fitting be installed on the hub.

HARDWARE

Periodically inspect all hardware on the mixer and engine / motor. Loose hardware can contribute to early component failure and poor performance.

NOTE: Some hardware is used to retain parts that have to move freely for correct operation of this unit. These items include the guard lifter and drum guard. The hardware for these items should be snug enough to prevent excessive play, yet loose enough to allow the parts to pivot freely.

TOWING

Before attempting to tow this mixer, check the state and local laws that apply to your intended route and check the following:

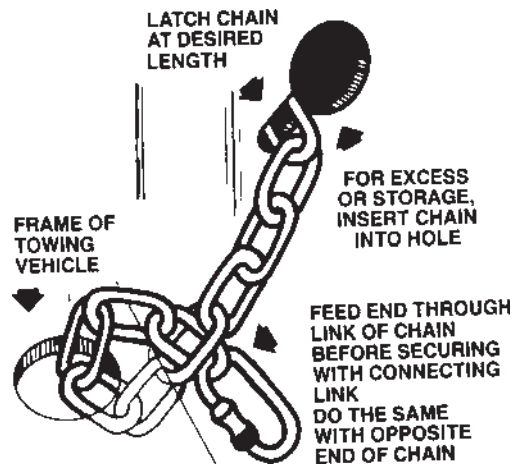

MAINTENANCE

Towing/Bull Gear Assy

1. Hitch attached to the towing vehicle securely.
2. Towpole fully extended and bolted to mixer securely.
3. Safety chain hooked up properly (see illustration below or decal on mixer front post).
4. Drum in the mixing position and drum latch engaged, clutch lever in the UP position.
5. Lug nuts and axle mount nuts tight.
6. On extendible axles, axle extended to full

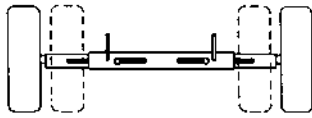

width and adjustment bolts tight.

7. On spring axles--spring mounting hardware tight, main springs and snubber springs not cracked or broken.
8. Tires in good shape and at proper inflation, for maximum safety and load capacity tires should be inflated to the following pressures.

Tire size 4.80 x 12 @ 60 P.S.I.

Tire size 6.50 x 13 @ 32 P.S.I.

WARNING

DO NOT EXCEED A TOWING SPEED OF 55 MILES/HR (90 KM/HR). FOR POOR ROAD CONDITIONS OR INCLEMENT WEATHER, REDUCE SPEED ACCORDINGLY.

Refer to FRAME AND DRUM ASSEMBLY, STANDARD AXLE ASSEMBLY and SPRING AXLE ASSEMBLY sections of this manual for parts identification and location.

BULL GEAR ASSEMBLY

1. Align Bull Gear keyway opposite to gear mesh.
2. Adjust pinion for tooth alignment and engagement using .010" feeler gauge.
3. Tighten all four (4) pillow block bolts before removing feeler gauge.

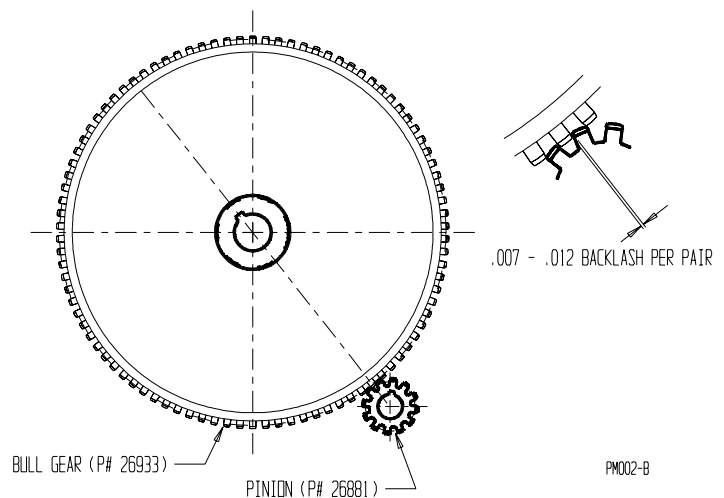

MAINTENANCE

Schedule

A. ENGINE--Daily check the oil levels in the engine and engine reduction unit. The engine warranty is **VOID** if run without oil . Since there are many options available on this mixer, consult the **ENGINE MANUAL** for specific recommendation as to oil level, oil type required and frequency of oil changes required. For maximum service life from the engine, follow those recommendations.

B. ENGINE AIR FILTER--A supply of clean, unrestricted air is essential for long engine life and maximum performance. Check the air filter daily and clean or replace as necessary, again following the specific instructions found in the **ENGINE MANUAL**. **NEVER** run the engine without the air cleaner.

C. DRUM SEALS--Greasing the drum seals is particularly important, as the lifetime warranty on the seal is **VOID** if they are not greased properly.

D. TRUNNIONS--Grease the trunnion to allow easy turning of the drum.

E. PILLOW BLOCK BEARINGS--Pillow block bearings need to be greased after each 40-50 hours of operation. Use any grade #1 lithium based grease.

F. BULL GEAR--Lightly grease the bull gear and pinion after each 250 hours of operation. Avoid over-greasing as this will attract dirt and accelerate wear.

G. WHEEL HUBS--Repack (4) tapered roller bearings in wheel hubs and replace wheel seals. Install washer and nut. Torque to 20 ft. lbs., back off one turn, torque to 7 ft. lbs., back off to first slot in nut and insert cotter key.

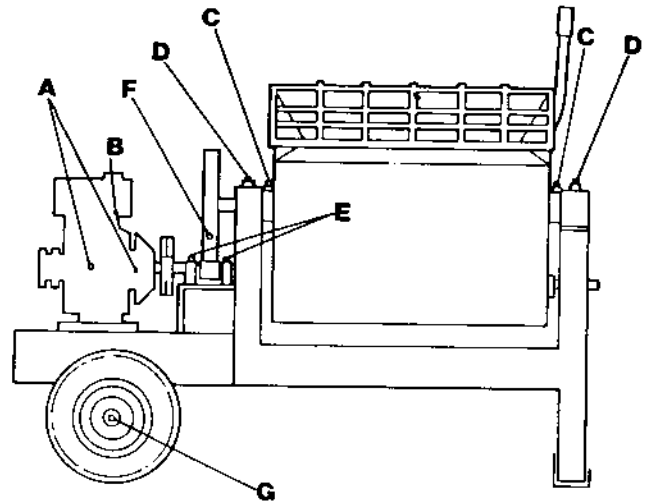

NOTE: Cowl removed for clarity. Do not operate mixer with cowl removed.

MAINTENANCE

Chart

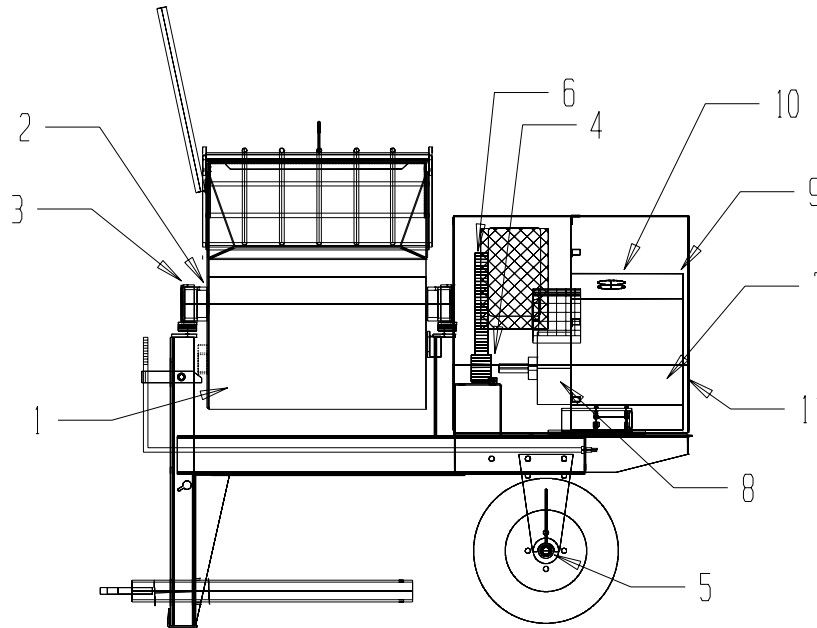

MIXER MAINTENANCE REFER TO MIXER OWNER'S MANUAL PROVIDED PRIOR TO OPERATING OR SERVICING EQUIPMENT	EVERY 5 HOURS OR DAILY	25 HOURS OR EVERY WEEK	50 HOURS OR EVERY MONTH	100 HOURS OR EVERY YEAR
1. MIXER: CLEAN MIXER INSIDE & OUT/REMOVE ALL BUILD UP	CLEAN			
2. DRUM SEALS: GREASE FITTINGS W/ LITHIUM BASE GREASE		GREASE		
3. TRUNNIONS: GREASE FITTINGS W/ LITHIUM BASE GREASE		GREASE		
4. PILLOW BLOCK BEARINGS: W/ LITHIUM BASE GREASE		GREASE		
5. WHEEL HUBS: REPACK EVERY YEAR W/ WHEEL BRG GREASE				EVERY YEAR
6. BULL GEAR: LIGHTLY GREASE EVERY 250 HRS				
ENGINE MAINTENANCE				
REFER TO ENGINE OWNER'S MANUAL PROVIDED PRIOR TO OPERATING OR SERVICING EQUIPMENT				
7. OIL LEVEL: 40F-110F SAE 30W SE,SF,SG	CHECK		CHANGE *	
BELOW 40F SAE 10W-30 SE,SF,SG	CHECK		CHANGE *	
8. REDUCTION OIL: SAE 30W SE,SF,SG				CHANGE
9. AIR FILTER: PRE-CLEANER WASH IN SOAP & WATER/APPLY OIL		CLEAN **		REPLACE
ELEMENT CLEAN BY TAPPING		CLEAN **		REPLACE
10. SPARK PLUG: CLEAN OR REPLACE			CLEAN	REPLACE
11. COOLING SYS & AIR SCREEN				CLEAN

* CHANGE OIL AFTER FIRST 5 HOURS, THEN EVERY 50 HOURS
CHANGE OIL EVERY 25 HOURS UNDER HEAVY LOADS OR HIGH TEMPERATURES
** CLEAN/CHANGE AIR FILTER MORE OFTEN UNDER DUSTY CONDITIONS

SAFETY 1ST DISCONNECT SPARK PLUG OR ELECTRIC CORD BEFORE SERVICING
DANGER DO NOT REFUEL WHEN ENGINE IS HOT OR SMOKE WHEN REFUELING
AVOID PROLONGED BREATHING OF EXHAUST GASES 56376-A

CALIFORNIA PROPOSITION 65 WARNING: Engine exhaust from this product contains chemicals known to the State of California to cause cancer, birth defects, or other reproductive harm.



*Bred Tough. TechnologyBorn to Work.
The Way It Ought To Be.*

Stone Construction Equipment, Inc.
P.O. Box 150, Honeoye, New York 14471
Phone: (800) 888-9926
Fax: 716-229-2363
e-mail: sceny@mcimail.com
www: stone-equip.com

A 100% employee-owned American manufacturer

© 1993 Stone Construction Equipment, Inc.
Printed in U.S.A.