

SOUTHERN-TOOL
1-800-458-3687
FAX: 1-865-675-8296

MOLDING KNIVES

W&H supplies just about any molding knives you need. We ship most off-the-shelf knives within 48hours—faster, if you're in a jam. The standard patterns shown in our style sheet are the most often used—and they're normally in stock.

Need special knives? Just send us an accurate tracing or a sample of the molding you wish to duplicate—we'll grind the knives for you! The workmanship will be superb, with quick delivery.

All knives are made from the *finest quality High Speed Steel* for long run production requirements.

If molding requires knives for top and bottom cuts, please specify by ordering: 1 set each top and bottom.

STANDARD PATTERNS

EDP NO.	PART NO.	EDP NO.	PART NO.	EDP NO.	PART NO.
10347	1001	10219	8016T	10202	C132
10348	1002	10220	8016B	10263	C871
10204	1003	10221	8025T	10264	C872
10205	1004	10222	8025B	10265	C873
10206	1005	10223	8052	10266	C874
10207	1006	10224	8057	10280	C875
10208	1007	10225	8058	10281	C876
10209	1008	10226	8063	10349	C877
10210	1009	10227	8064	10352	C878
10211	1010	10228	8065	10353	C879
10212	1011	10229	8070	10362	C880
10213	1012	10279	8071	10363	C881
10214	1013	10230	8076	10364	C882
10215	1014	10231	8077	10365	C883
10216	1016	10278	8078	10366	C884
10217	1017	10277	8079	10367	CP101
10218	1018	10276	8081	10368	CP102
10237	1019	10232	8090	10369	CP103
10254	1020	10233	8140	10290	CR891T
10255	1021	10361	8141	10291	CR891B
10256	1022	10234	8610	10340	CR892T
10257	1023	10235	8611	10341	CR892B
10258	1024	10236	8793	10359	CR893T
10342	1025	10267	8794	10360	HR100
10343	1026	10350	AW500	10201	NY100
10344	1027	10351	AW501	10370	R101
10345	1028	10292	B3125	10371	R102
10346	1029	10293	B3750	10372	R103
10354	1030	10294	B4375	10373	R104
10355	1031	10295	B5000	10259	RP871
10356	1032	10296	BC100	10260	RP872
10357	1033	10297	BC200	10261	RP873
10358	1034	10298	BC300	10262	RP874
				10203	WP691

SPECIAL PATTERNS — Subject to CONFIRMATION OF FACTORY

Prices of knives for patterns not listed above are based on over-all width of knives. NOT molding.

To determine correct knife size add 1/8" to both ends of molding for clearance purposes.

1" or less	3 1/2" or less	5 1/2" or less
1 1/2" or less	4" or less	6" or less
2" or less	4 1/2" or less	6 1/2" or less
2 1/2" or less	5" or less	7" or less
3" or less		



Call 1-800-458-3687
For Pricing!



Payment in advance is required for all special knives, no COD orders are accepted.

Orders for special knives may not be cancelled or returned for credit.

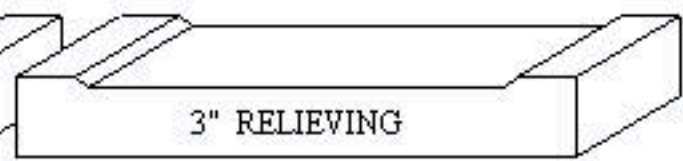
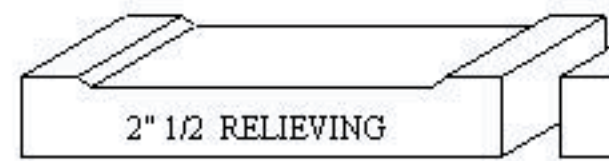
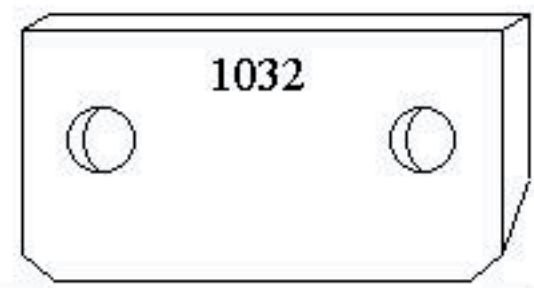
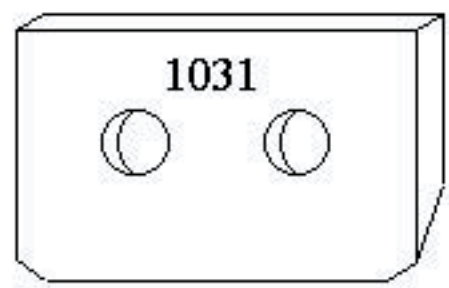
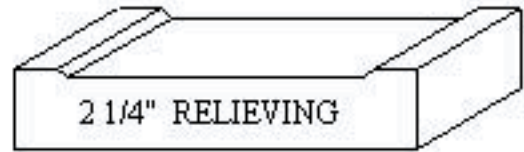
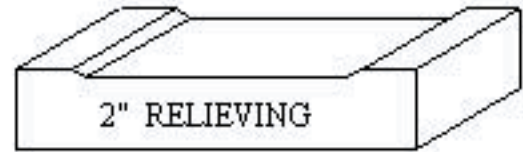
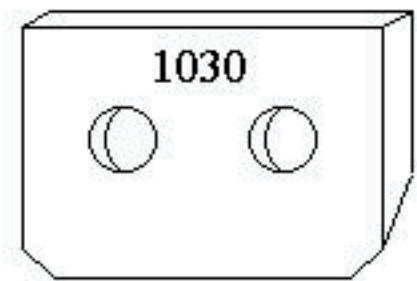
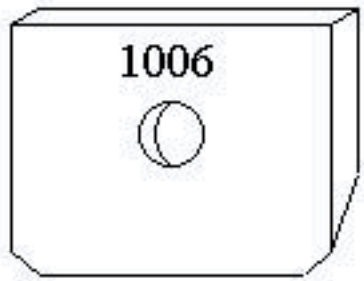
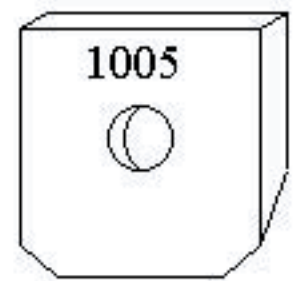
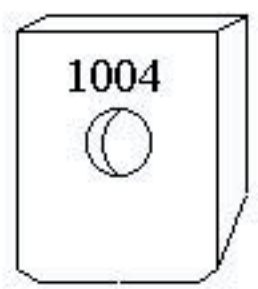

②

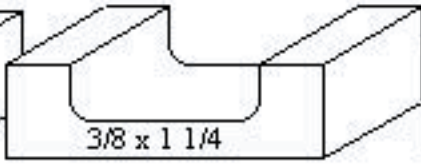
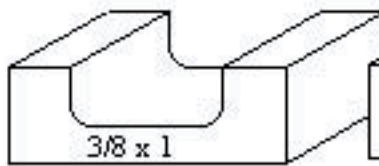
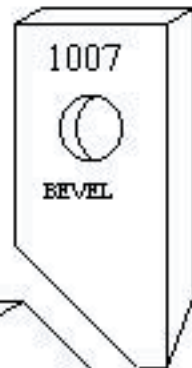
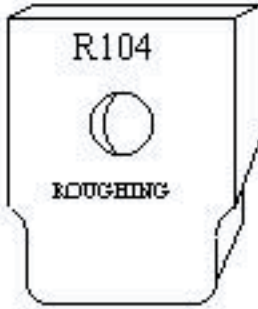
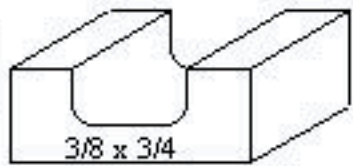
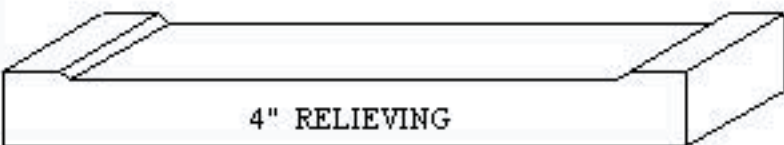
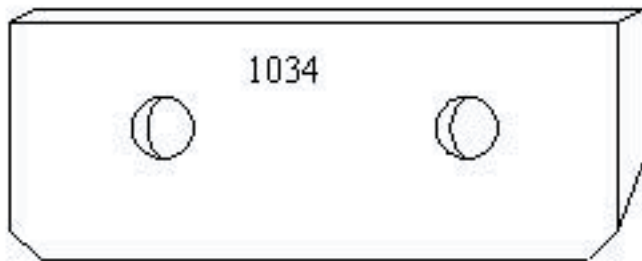
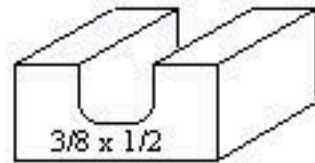
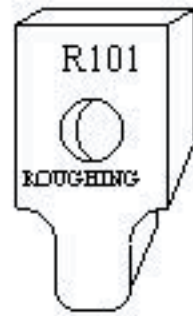
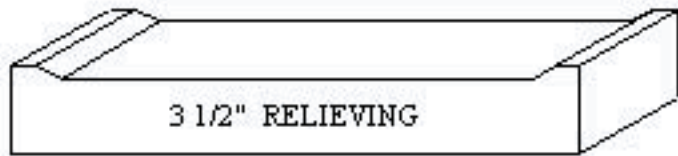
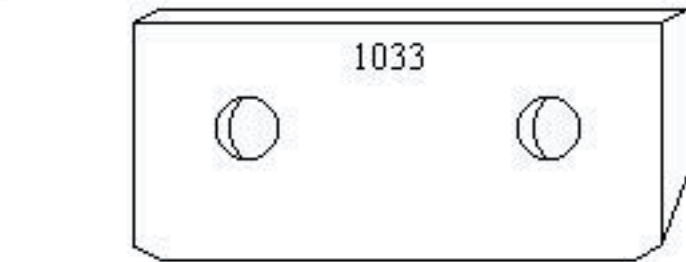

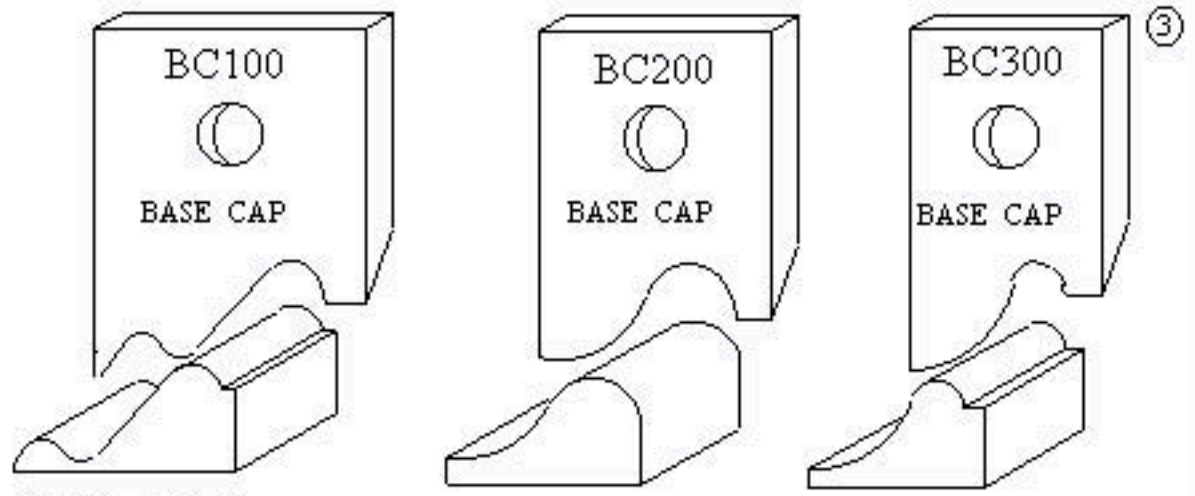

1 1/16" x 1 7/16"

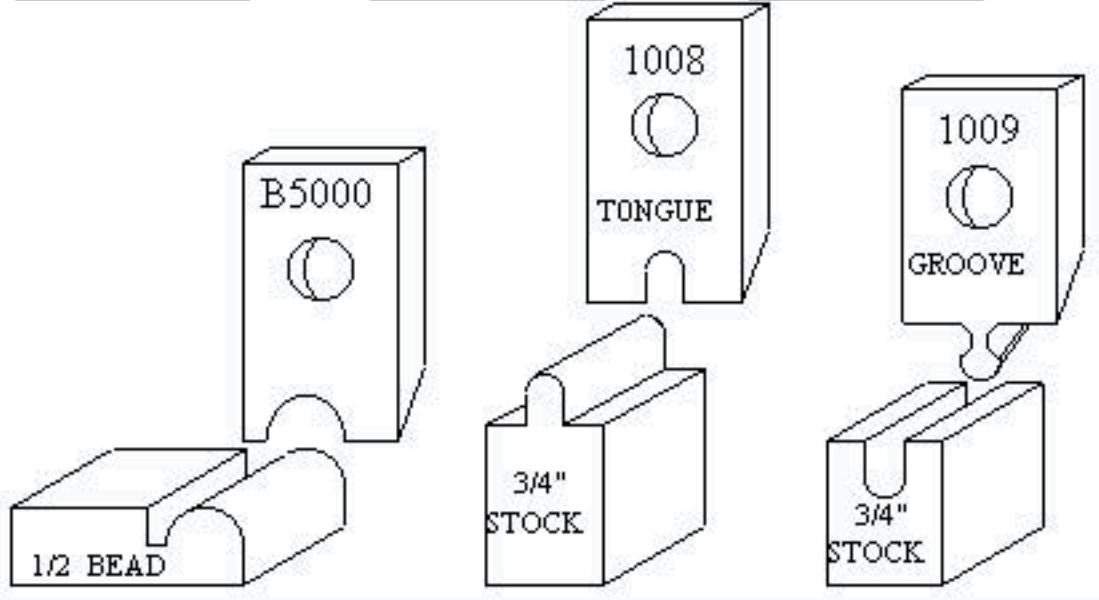
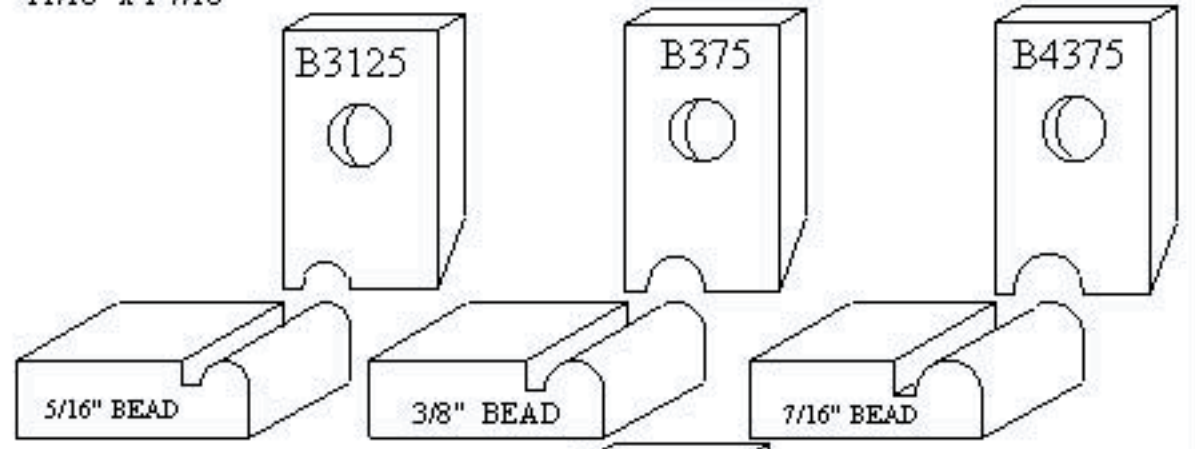

④

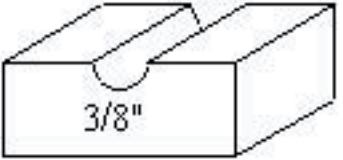
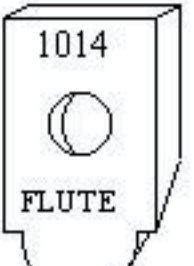
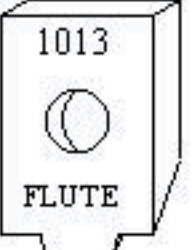
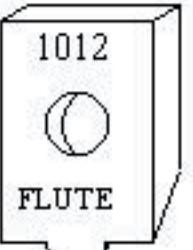
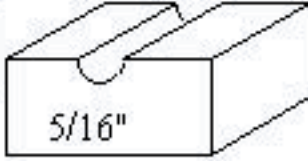
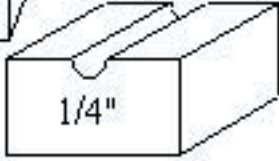
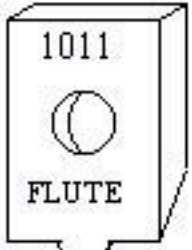
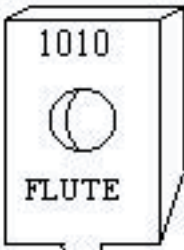
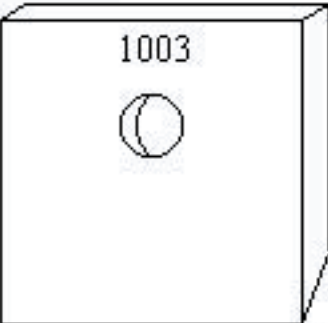
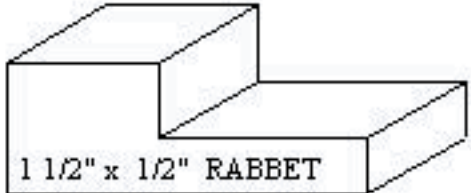
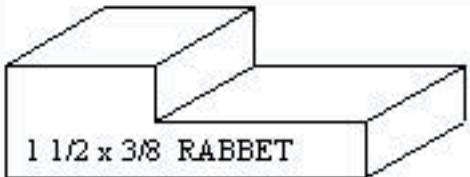
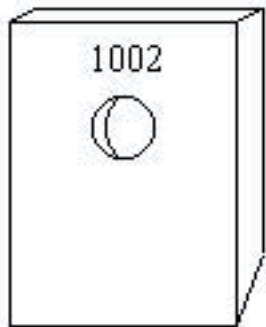
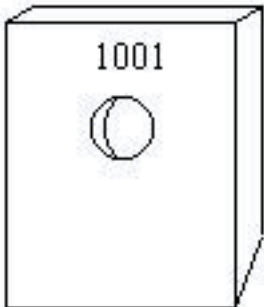

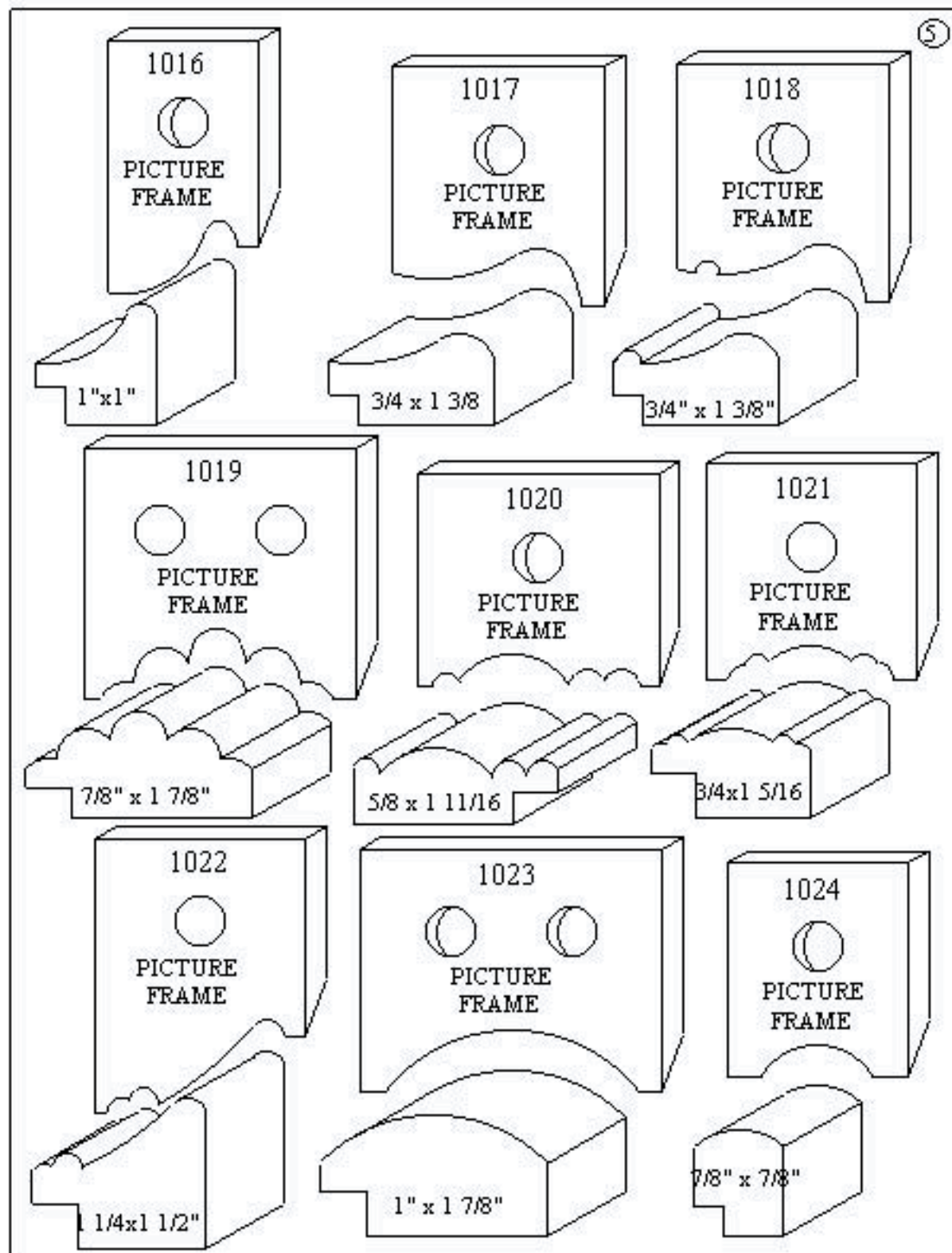

⑥

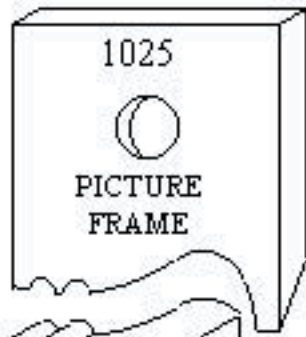

3/4" x 1 3/8"

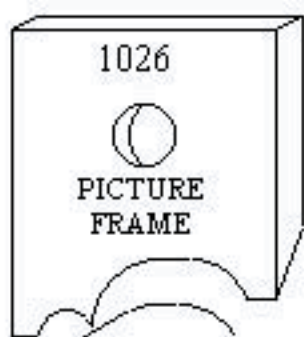

7/8" x 1 1/4"

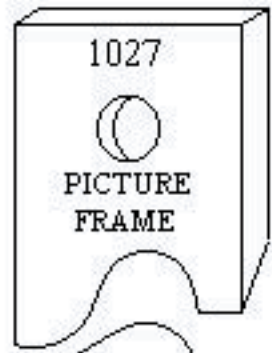

1 1/8 x 1 3/16

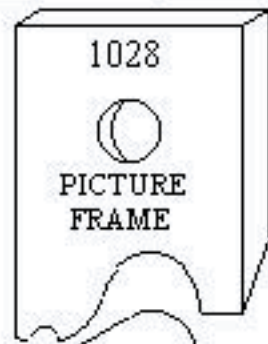

1 1/8" x 1 3/16"

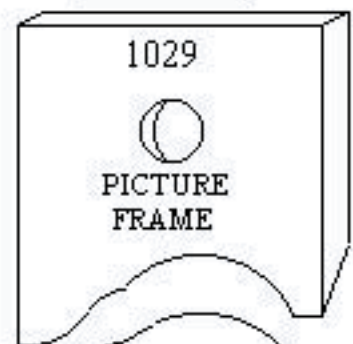

1" x 1 5/8"

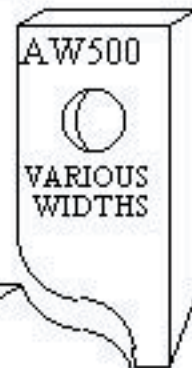

3/4" STOCK

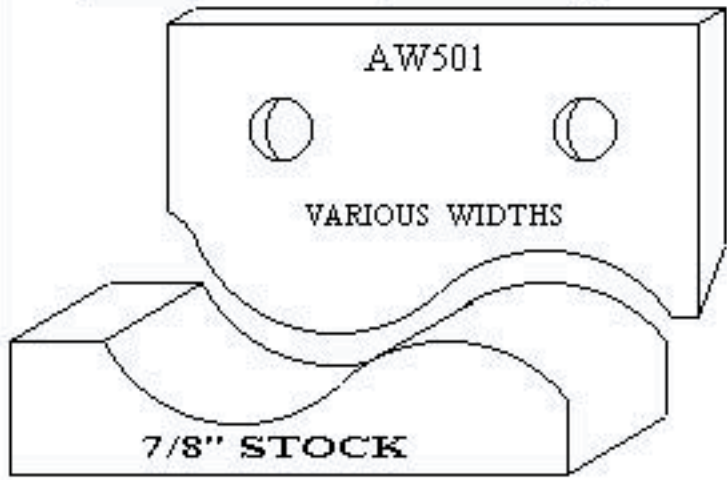

7/8" STOCK

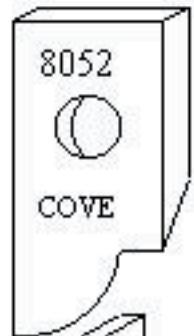

5/4 x 3/4

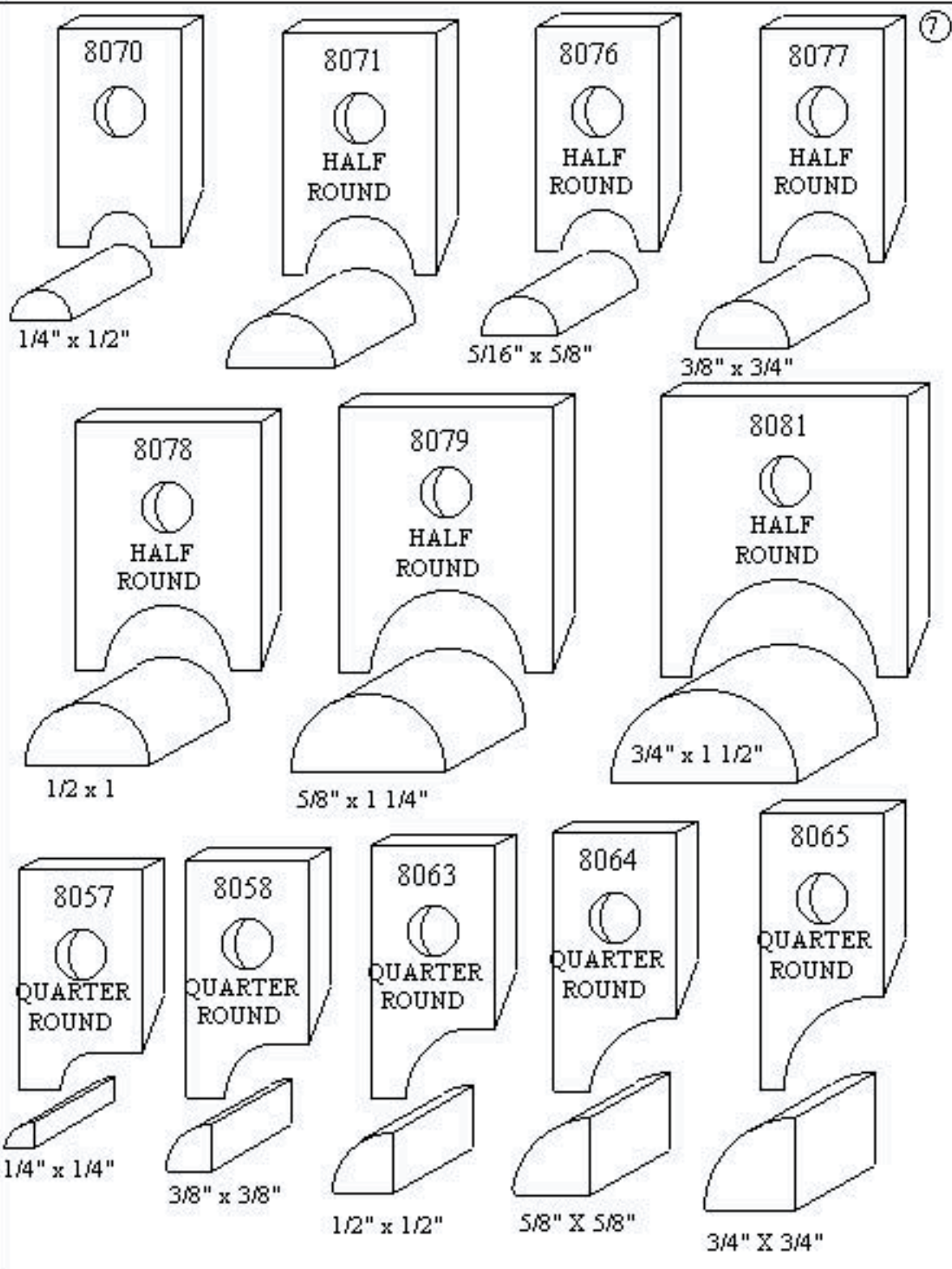

⑧

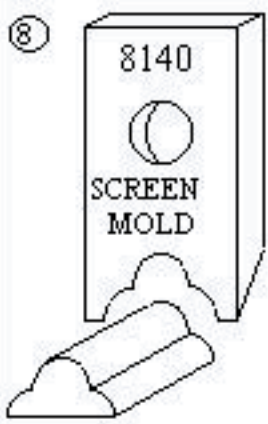

3/8" x 3/4"

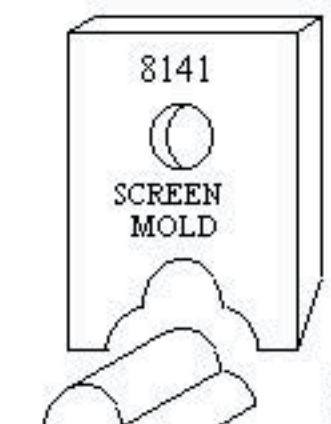

1/2 x 1

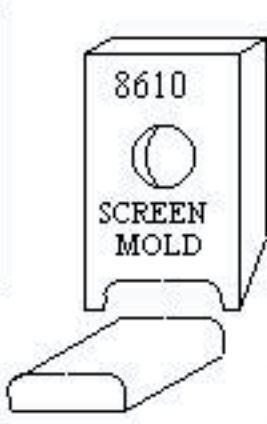

1/4" x 3/4"

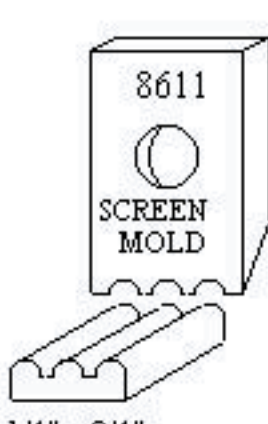

1/4" x 3/4"



3/4" x 1 1/8"



3/4" x 1 3/8"

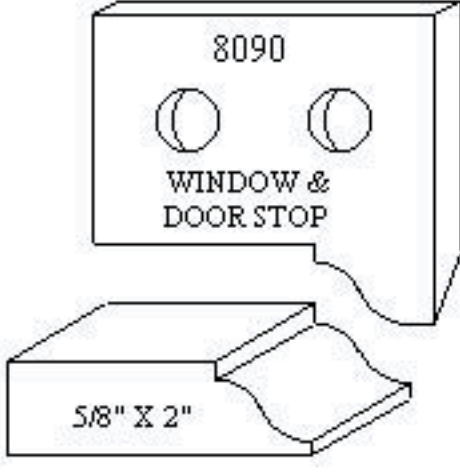

5/8" X 2"

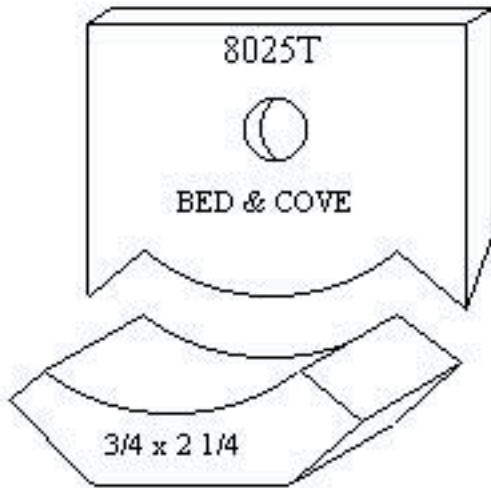

3/4 x 2 1/4

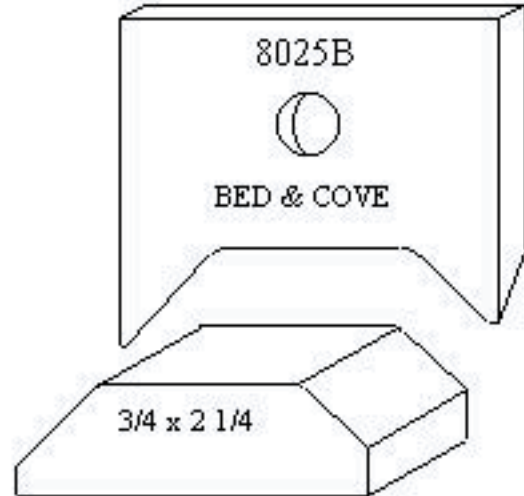

3/4 x 2 1/4

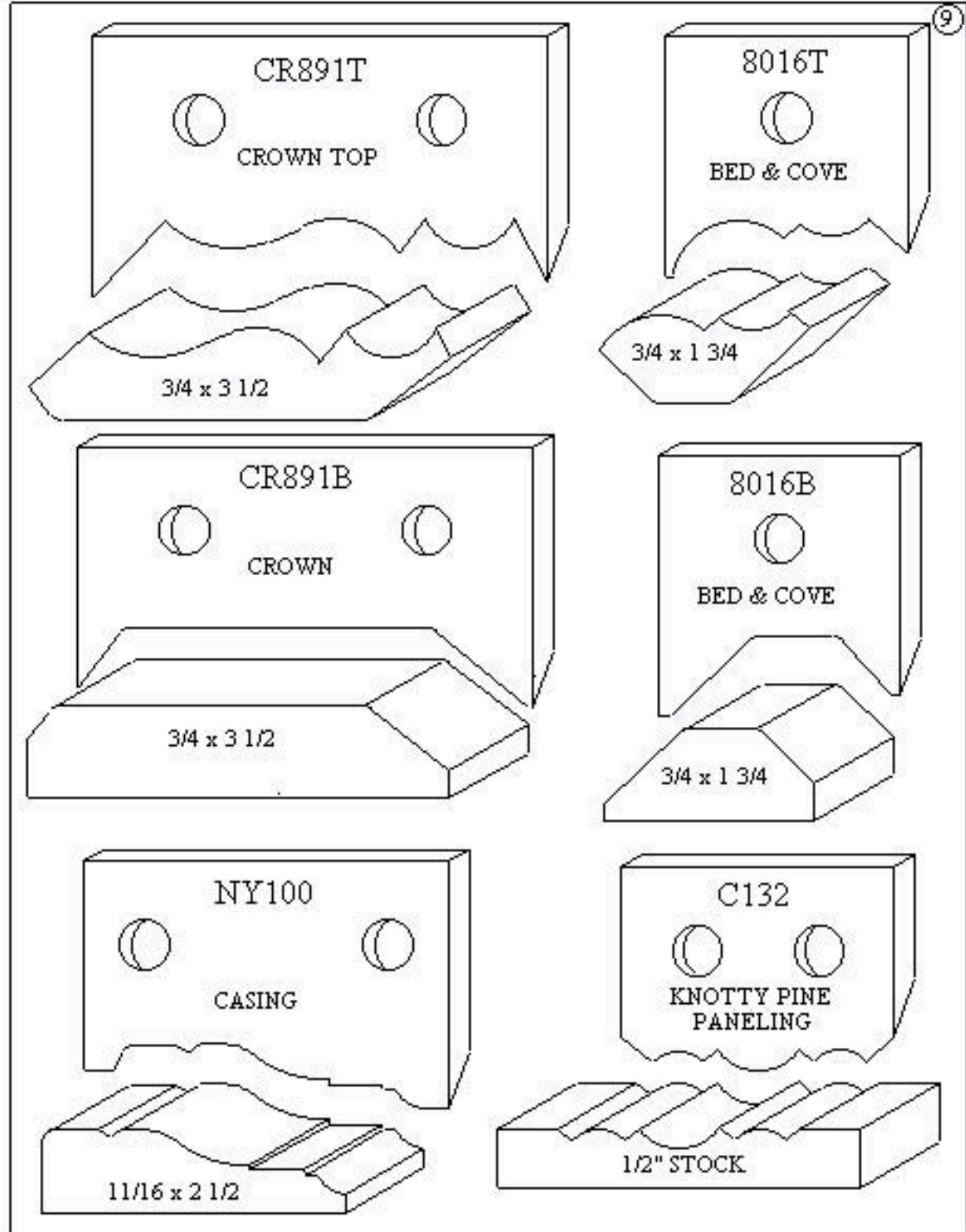

⑩

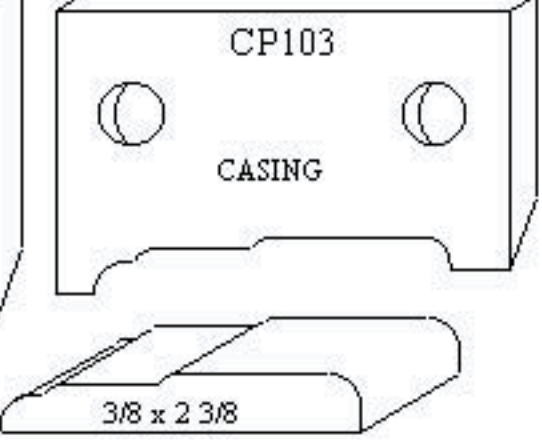
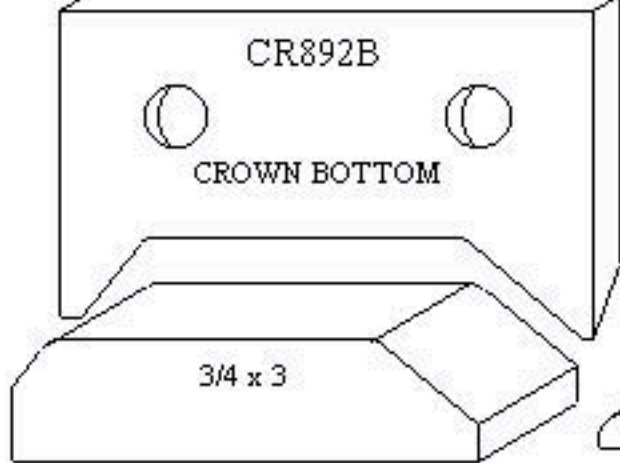
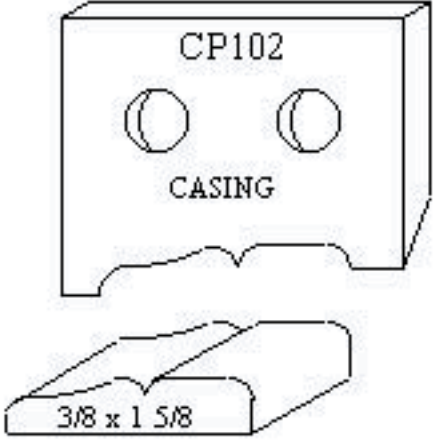
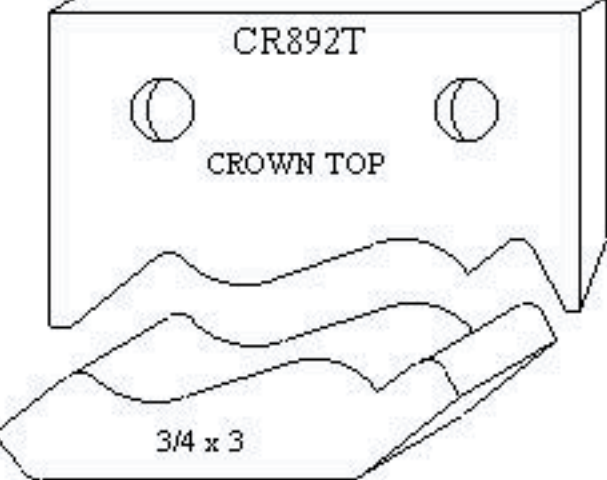
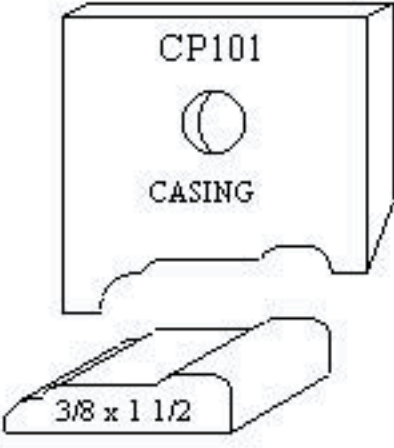
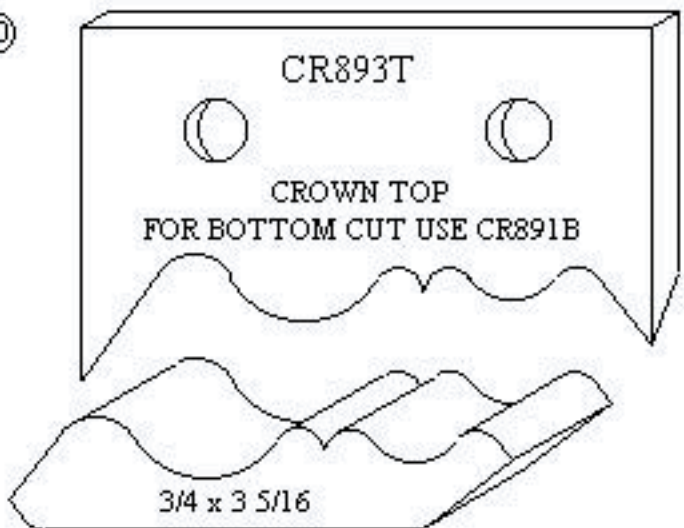

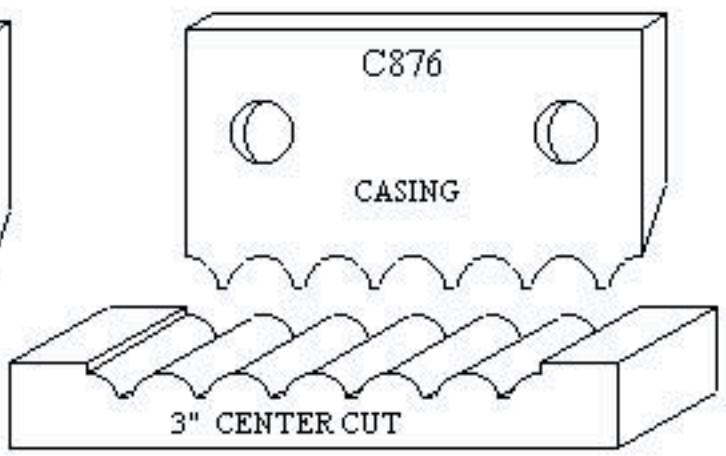
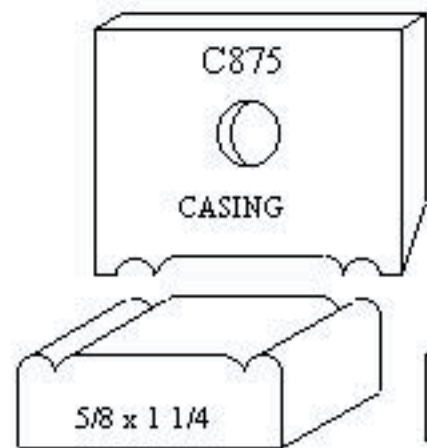
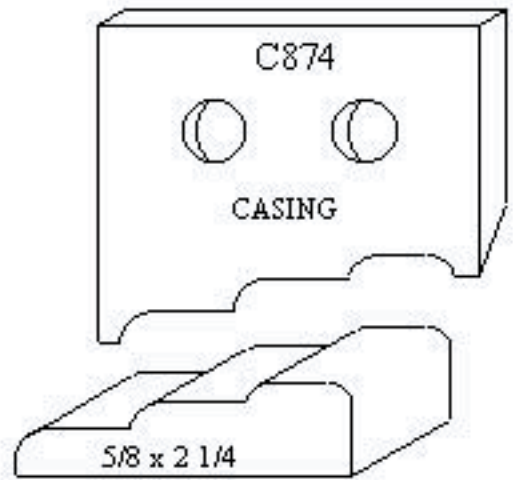
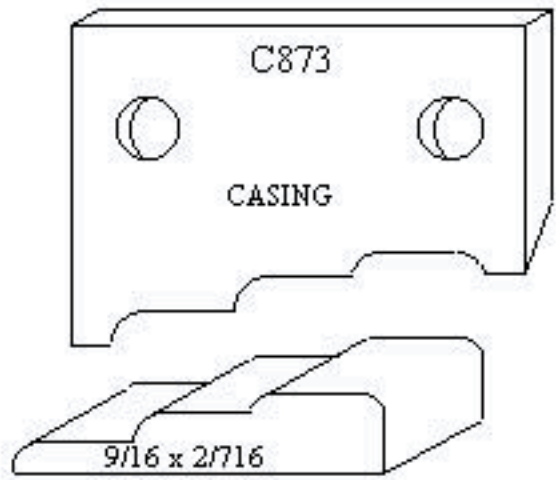
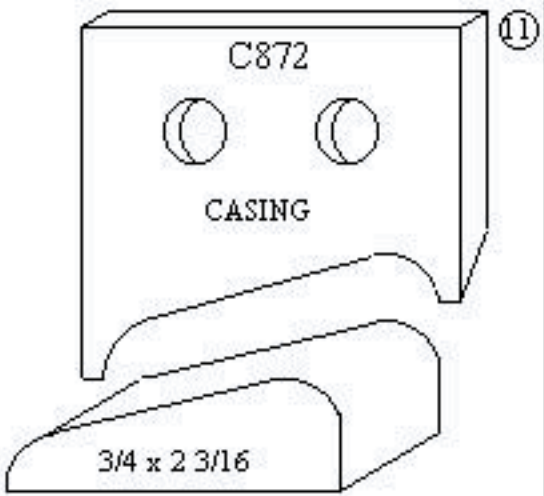
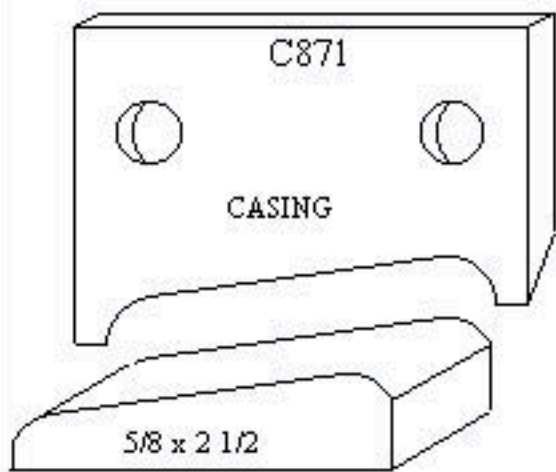

⑫

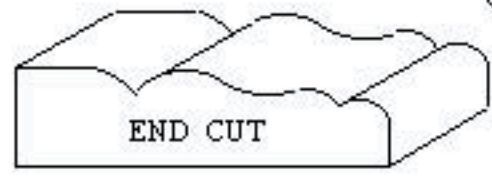
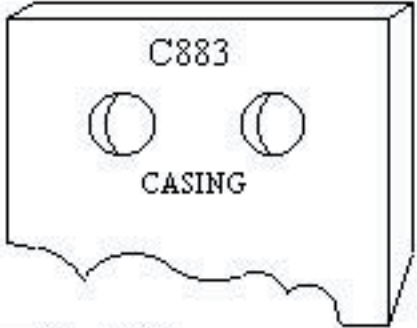
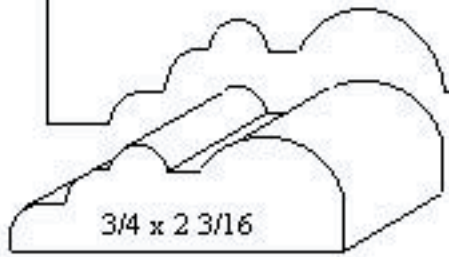
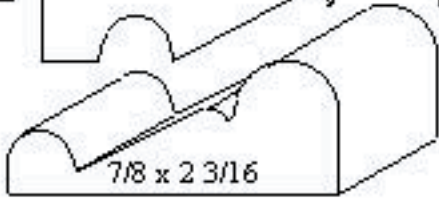
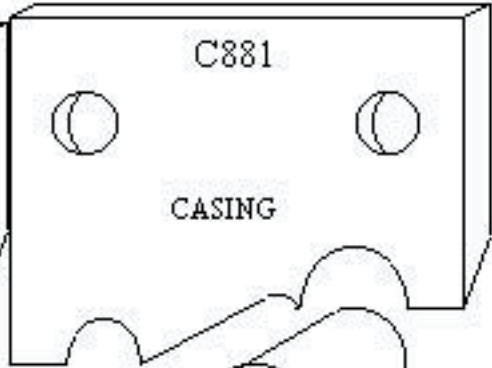
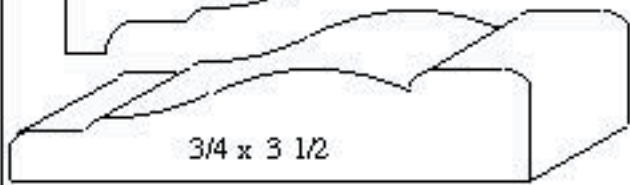
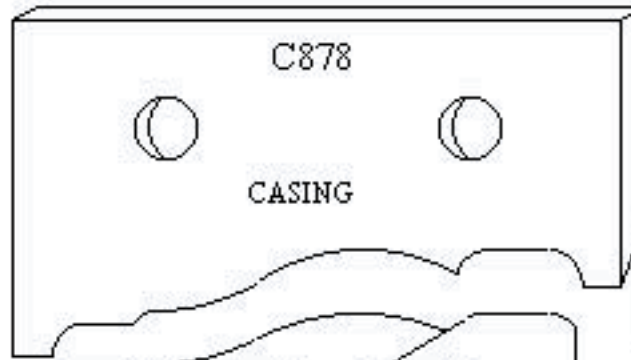
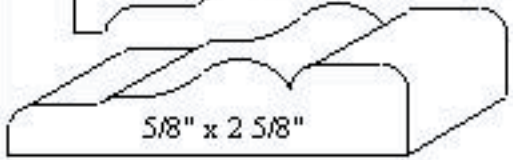
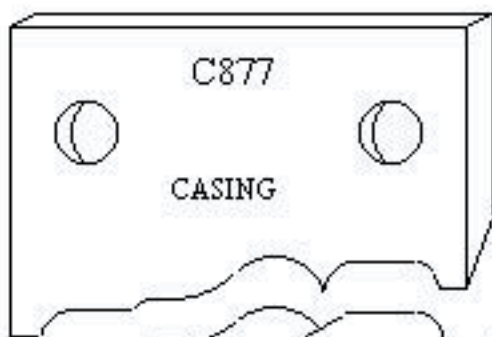

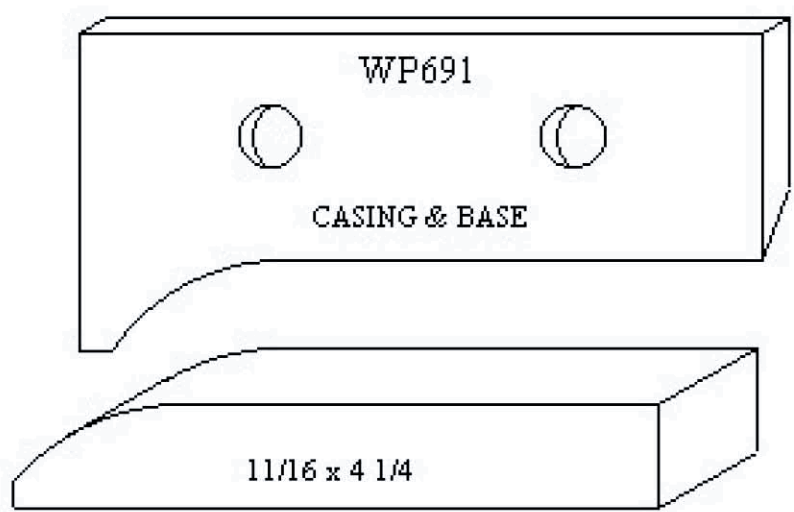
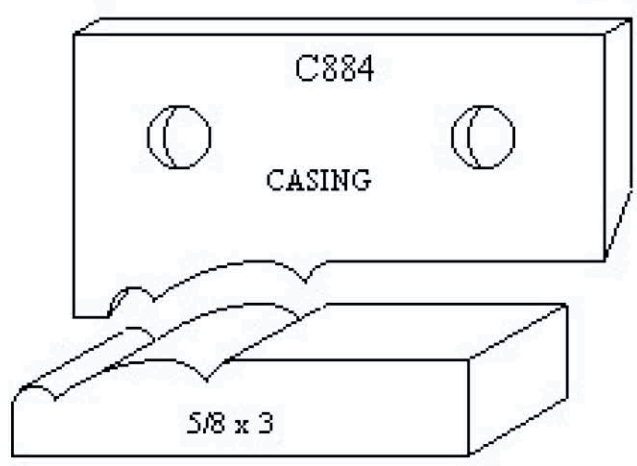
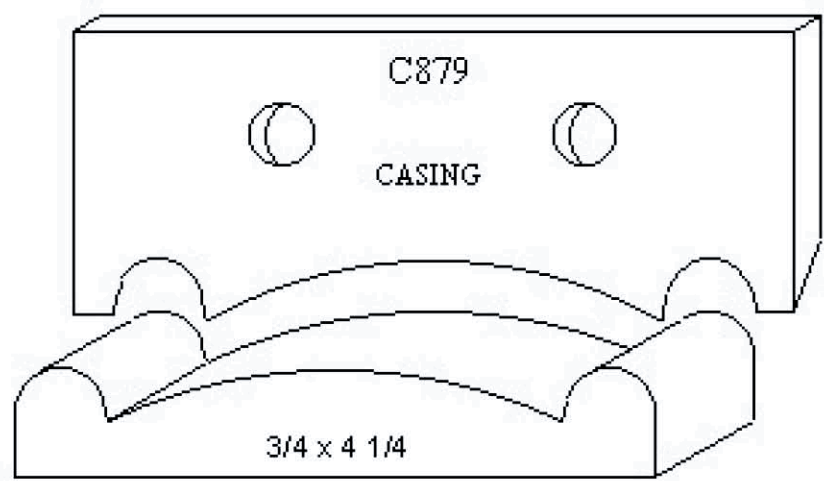

(4)

