

DRIVE CLEAT AUXILIARY ROLL SET

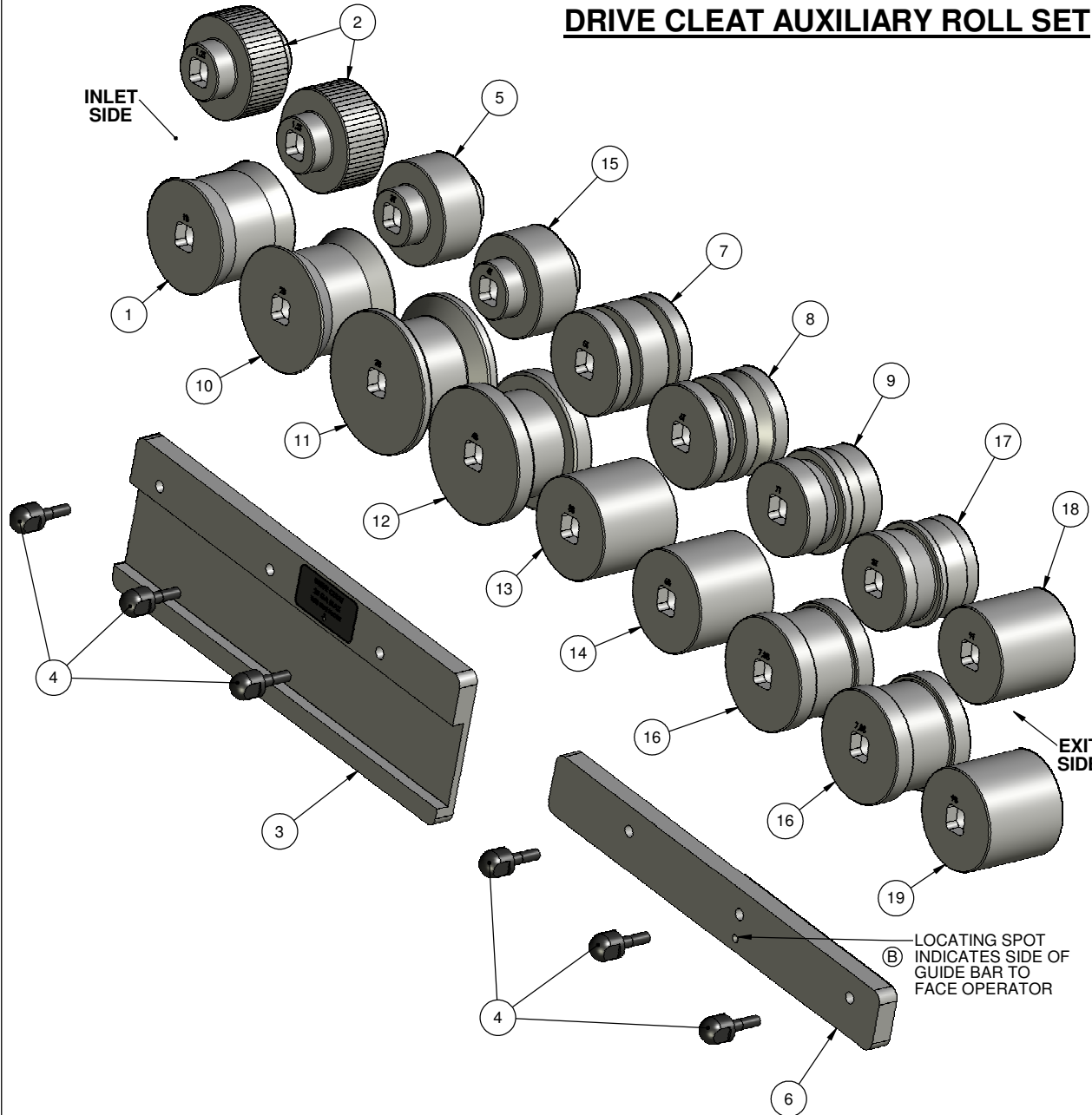

REVISIONS				
ZONE	REV.	DESCRIPTION	DATE	APPROVED
	A	INITIAL RELEASE	10/3/08	SSL
	B	ADDED LOCATING SPOT TO GUIDE BAR	11/21/2008	SSL
	C	ITEM 3 WAS AX-1821; ITEM 4 WAS QTY 4; ITEM 6 WAS AX-1017	07/22/10	DRP

INSTALLATION INSTRUCTIONS:

1. INSTALL ROLLERS, MARKED "1,2T" & "1B", ONTO THE SHAFTS AT THE INLET SIDE OF MACHINE, PLACING "1,2T" ON THE UPPER SHAFT AND "1B" ON THE LOWER SHAFT.
2. REPEAT THE ABOVE PROCEDURE FOR THE REMAINING ROLLERS IN NUMERIC ORDER.
3. ALL ROLLERS MARKED "T" SHOULD BE ON THE TOP SHAFTS AND ROLLERS MARKED "B" SHOULD BE ON THE BOTTOM SHAFTS.
4. ALL ROLLER MARKINGS MUST FACE OUTWARD, OR TOWARDS THE OPERATOR.
5. MOUNT INLET GUIDE BAR (ITEM 3) ON THE INLET SIDE OF THE MACHINE. GUIDE BAR TO BE BOLTED INTO THREADED HOLES IN TABLETOP OF MACHINE, (2.15" FROM THE FRONT EDGE OF THE ROLLERS).
6. MOUNT EXIT GUIDE BAR (ITEM 6) ON THE EXIT SIDE OF THE MACHINE. GUIDE BAR TO BE BOLTED INTO THREADED HOLES IN TABLETOP OF MACHINE, (1.64" FROM THE FRONT EDGE OF THE ROLLERS). LOCATING SPOT ON GUIDE BAR MUST BE FACING OPERATOR.

RAMS 2014 - AUXILIARY MACHINE

ITEM NO.	PART NUMBER	DESCRIPTION	QTY.
1	AX-1801	#1 STATION BOTTOM CLEAT ROLLER	1
2	AX-1801,2-T	#1 & 2 STATIONS TOP CLEAT ROLLER	2
3	AX-1821-2	GUIDE BAR, DRIVE CLEAT, INLET, EXTRA WIDE	1
4	2054	ADJUSTING BOLT:1/4-20 THREAD	6
5	AX-1803-T	#3 STATION TOP CLEAT ROLLER	1
6	AX-1017-1	GUIDE BAR, DRIVE CLEAT, EXIT	1
7	AX-1805-T	#5 STATION TOP CLEAT ROLLER	1
8	AX-1806-T	#6 STATION TOP CLEAT ROLLER	1
9	AX-1807-T	#7 STATION TOP CLEAT ROLLER	1
10	AX-1802-B	#2 STATION BOTTOM CLEAT ROLLER	1
11	AX-1803-B	#3 STATION BOTTOM CLEAT ROLLER	1
12	AX-1804-B	#4 STATION BOTTOM CLEAT ROLLER	1
13	AX-1805-B	#5 STATION BOTTOM CLEAT ROLLER	1
14	AX-1806-B	#6 STATION BOTTOM CLEAT ROLLER	1
15	AX-1804-T	#4 STATION TOP CLEAT ROLLER	1
16	AX-1807,8-B	#7 & 8 STATIONS BOTTOM CLEAT ROLLER	2
17	AX-1808-T	#8 STATION TOP CLEAT ROLLER	1
18	AX-1809-T	#9 STATION TOP CLEAT ROLLER	1
19	AX-1809-B	#9 STATION BOTTOM CLEAT ROLLER	1

DIMENSIONS ARE IN INCHES TOLERANCES: FRACTIONAL ± 1/16 ANGULAR: MACH ± BEND ± TWO PLACE DECIMAL ±.01 THREE PLACE DECIMAL ±.005		<table border="1"> <tr> <th>NAME</th> <th>DATE</th> </tr> <tr> <td>SSL</td> <td>9/2/08</td> </tr> <tr> <td>CHECKED</td> <td></td> </tr> <tr> <td>ENG APPR.</td> <td></td> </tr> <tr> <td>MFG APPR.</td> <td></td> </tr> <tr> <td>Q.A.</td> <td></td> </tr> </table>	NAME	DATE	SSL	9/2/08	CHECKED		ENG APPR.		MFG APPR.		Q.A.		HORIZON SYSTEMS MACHINING 9121 58TH PLACE KENOSHA, WI 53144 PH: 262-605-1122 FAX: 262-605-1198
NAME	DATE														
SSL	9/2/08														
CHECKED															
ENG APPR.															
MFG APPR.															
Q.A.															
MATERIAL: SEE BOM FINISH: N/A DO NOT SCALE DRAWING	TITLE: DRIVE CLEAT ROLLERS, SQ. DR. SIZE: C DWG. NO.: RAMS AUX-1800 REV: C	SCALE: 1:1.85 SHEET 1 OF 1													