

OWNERS MANUAL

Small Concrete Saw



MODEL:
C1318P

FORM <<7317A 3/2011



WARRANTY

Norton warrants all products manufactured by it against defects in workmanship or materials for a period of one (1) year from the date of shipment to the customer.

The responsibility of Norton under this warranty is limited to replacement or repair of defective parts at Norton's Gainesville, Georgia factory, or at a point designated by it, of such part as shall appear to us upon inspection at such point, to have been defective in material or workmanship, with expense for transportation borne by the customer.

In no event shall Norton be liable for consequential or incidental damages arising out of the failure of any product to operate properly.

Integral units such as **gasoline engines, electric motors, batteries, tires, transmissions, etc.**, are excluded from this warranty and are subject to the prime manufacturer's warranty.

This warranty is in lieu of all other warranties, expressed or implied, and all such other warranties are hereby disclaimed.

Important: Before placing equipment in operation, record the following information.

MODEL: _____ **SERIAL NO.** _____

PURCHASE FROM: _____

ADDRESS: _____

CITY _____ **STATE** _____ **ZIP** _____

TELEPHONE NO. _____

Before using this equipment, make sure that any person using it reads and understands the instructions in this owner's manual.

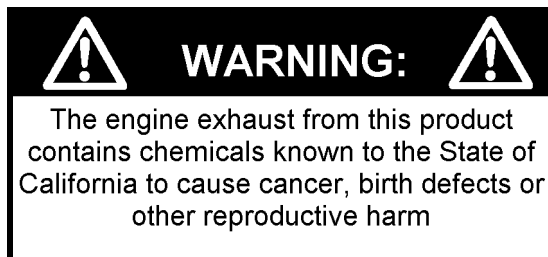

Table of Contents

CONTENTS	PAGE
I. Preparation	
A. Safety Precautions	4-6
B. Assembly	7
C. C1318P Series Concrete Saw Specifications	8
D. Engine Specifications	9
E. Pointer Alignment	9
II. Operation	
A. Blade Installation	9-10
B. Starting The Engine	10-11
C. Water Supply	12
D. Operating The Saw	12-13
E. Cutting Technique	13
III. Maintenance	
A. Engine	14-15
B. Bearings	15-16
C. V-Belts	16-20
D. Depth Control	21
IV. Parts List Section	
A. Ordering Information	22
B. Parts Drawing and Service Parts List	23-33
Depth Control And Depth Lock Group	23
Handle Bar Group	24
Blade Guard Group	25
Blade Shaft Group	26-27
Belt Tensioning Group	28
Engine Mount Group	29
Main Frame Group	30
Water Control Group	31-32
Front Pointer Group	33



Read Owners Manual Before Use



Safety Alert Symbol: Information Following This Symbol Is Very Important.

Use Only Norton Diamond Blades

I. PREPARATION

A. Safety Precautions

Important! The following safety precautions must always be observed.

Hazard Symbols



Fuel (gasoline) is extremely flammable and its vapors can explode if ignited. Store gasoline only in approved containers, in well-ventilated, unoccupied approved areas, and away from sparks or flames. Do not fill the fuel tank while the engine is hot or running. Do not start the engine near spilled fuel. Never use the fuel as a cleaning agent



Engine components can get extremely hot from operation. To prevent burns, do not touch the engine or related parts while the engine is running or immediately after it is turned off. Never operate the engine with any heat shields or guards removed.



Keep all guards in place when operating any piece of equipment



Keep hands, feet, hair, and clothing away from all rotating parts



Lethal Exhaust Gas: use only in well ventilated areas. Engine exhaust gases contain poisonous carbon monoxide, which is odorless, colorless, and can cause death if inhaled. Avoid inhaling exhaust fumes, and never run the engine in a closed building or confined area.



Never tamper with the governor components of settings to increase the maximum speed. Severe personal injury and damage to the engine or equipment can result if operated at speed above maximum. Always obey the maximum speed rating of blade.



DO NOT LIFT THE SAW BY THE HANDLE BARS

WARNING

Dust and Silica Warning

Grinding/cutting/drilling of masonry, concrete, metal and other materials can generate dust, mists and fumes containing chemicals known to cause serious or fatal injury or illness, such as respiratory disease, cancer, birth defects or other reproductive harm. If you are unfamiliar with the risks associated with the particular process and/or material being cut or the composition of the tool being used, review the material safety data sheet and/or consult your employer, the material manufacturer/supplier, governmental agencies such as OSHA and NIOSH and other sources on hazardous materials and make certain to comply with all product warnings and instructions for the safe and effective use of the material being cut. California and some other authorities, for instance, have published lists of substances known to cause cancer, reproductive toxicity, or other harmful effects.

Control dust, mist and fumes at the source where possible. In this regard use good work practices and follow the recommendations of the manufacturer/supplier, OSHA/NIOSH, and occupational and trade associations. Water should be used for dust suppression when wet cutting is feasible. When the hazards from inhalation of dust, mists and fumes cannot be eliminated through engineering controls such as vacuum and/or water mist, the operator and any bystanders should always wear a respirator approved by NIOSH/MSHA for the material being cut.

Use Approved:



Eye Protection



Hearing Protection



Respiratory Protection



Head Protection

1. Before mounting any blade on the saw, the blade should be inspected for any damage which might have occurred during shipment, handling or previous use.
2. The blade collars and arbors should be cleaned and examined for damage before mounting the blade.
3. The blade must be properly fitted over the arbor with the drive pin on the outside collar projecting through the drive pin hole on the blade and inside collar.
4. The blade shaft nut, which is a left-hand thread nut, must be tightened securely against the outside blade shaft collar.
5. The blade must be operated within the specified maximum operating speed listed on the blade.
6. Turn water control valve to full to provide adequate coolant (4 to 6 gallons per minute) for diamond blades and wet cutting abrasive blades. Insufficient coolant could result in severe blade breakage or diamond segment separation.
7. The blade guard must be in place with the nose guard down and locked when the saw is running.
8. The operator should wear safety glasses and any other appropriate safety equipment.
9. When starting the saw, the operator should stand away and to the side of the blade.
10. If for any reason the saw should stall in the cut, raise the blade out of the cut. Check the outside blade shaft collar and nut for tightness. Inspect the blade for damage before restarting the saw. Use caution when resuming a cut. Be certain that the blade is in alignment with the previous cut.
11. During cutting operations do not exert excess side pressure on the handles as a method of steering. Do not force the blade into the cut by lowering the blade too fast or by pushing the saw too fast.



You Are Responsible For Your Safety!!!

I. PREPARATION

B. Assembly

The compact concrete saws are shipped completely assembled and ready for use except for diamond blade, gasoline, oil, and handle bar. Inspect the saw for shipping damage. If any damage is found, contact the shipper immediately and file a freight claim. Norton Clipper is not responsible for any freight-related damages. Remove the saw from the pallet. Reverse the position of the handlebars so that the handle bar sticks out towards the operator. Adjust the handlebars to the desired height. Align the hole located in the operator's right side of the Handle Bar Assembly with the M10 Weld Nut in the frame. Attach the handlebars to the saw with the supplied hardware. The Operator's Right Side Screw part# 028098 will pass through a hole in the Handle Bar Assembly. Tighten 029098 to the Handle Bar Assembly and then tighten the M10 Jam Nut 027006. Tighten 027021 to the Handle Bar Assembly and then tighten the M10 Jam Nut 027006. Read and understand the remaining sections of this Owners Manual. NOTE: Do not install the blade until it is time to use the saw. ANSI regulations prohibit the transportation of any concrete saw with the blade installed.



DO NOT LIFT THE SAW BY THE HANDLE BARS

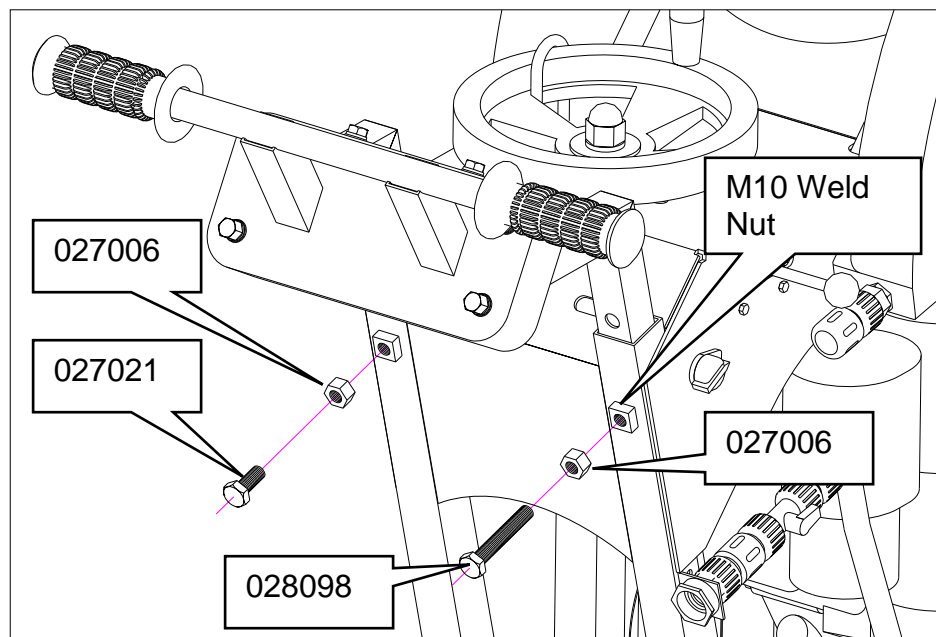

Part #	Description	QTY
027021	Screw DIN931 M10 x 25 Hex Head Cap	1
028098	Screw DIN933 M10 x 65 Hex Head Cap	1
027006	M10 Jam Nut DIN934	2

C. C1318P Series Concrete Saw Specifications

Dimensions/Weight	
Length (Working)	45.66" (1160 mm)
Length (Transport)	33.50" (850 mm)
Width	39.50" (1003 mm)
Height	39" (990 mm)
Weight	220 lbs (100 kg)
Engine	
Engine Mfg.	Honda
Spec No.	GX390K1QXC9
Engine Type	Single Cylinder 4 Cycle
Horse Power - Gross	13 hp* (9.5kW) @ 3,600 rpm
Max Torque – Gross	19.5 ft-lbs (26.5 Nm, 2.7 kg-m) @ 2,500 rpm
Model	GX390K1QXC9
Model	GX390
Cooling System	Air
Oil Capacity	1.16 US qt (1.1 liter)
Fuel Capacity	1.79 US gal (6.5 liter)
Fuel Type	Unleaded Gasoline (86 pump octane)
Low Oil Sensor	Yes
Air Filtration	Four Stage Cyclone
Characteristics	
Max Blade	Ø18" (450 mm)
Depth of Cut 18" (406 mm)	6.75" (172 mm)
16" (406 mm)	5.75" (146 mm)
14" (356 mm)	4.75" (121 mm)
12" (305 mm)	3.75" (95 mm)
Arbor Bore	1" (25.4 mm)
Blade Shaft Locking Device	Machined Into Flats Of Tight Collar
Blade Shaft Speed	2,573 rpm
Depth Control	Hand Wheel With Screw Feed
Depth Lock	Standard
Depth Gauge	Customer Installed Accessory
Number Of Belts	Single Ten (10) Groove K Section Belt
Blade Guard Type	Hinged, All Steel Construction
Right or Left Side Cutting	Yes
Lifting Bale	Built In
Handle Bars	Adjustable, Stays Level At All Times
Water Tank	Standard
Water Tank Capacity	6.5 US Gallons (24.6 liter)
Water Hose Connector	Standard Garden Hose With Flow Control Valve
Recessed Rear Wheels	Standard
Sound pressure ¹	88 db(A)
Sound power ¹	105 db(A)
Vibration emission value	9.18 ft/ s ² (2.8 m/s ²) (according to EN 12096)

* = Horse power and Torque ratings are Gross Horse power and are supplied by the engine manufacturer. Actual output of the engine will vary due to many factors including operational speed of engine, environmental conditions, maintenance, fuel, and other variables. Saint-Gobain Abrasives, Inc. makes NO claim to actual or gross horse power and torque ratings. 1) The sound measures have been made following pr EN 12638, Annex A; 2) Floor sawing, grooving and milling machines – Safety"

D. Engine

Prior to attempting to operate the engine, read the information contained in the engine owner's manual. An engine owner's manual is supplied with every gasoline powered concrete saw.

1. **Check Oil:** Add oil if low. Refer to the engine owner's manual for the recommended SAE viscosity grades. Capacity of oil is 1.16 US quarts (1.1 liters)
2. **Check Fuel:** Fill if low. Use only unleaded gasoline with a pump sticker octane rating of 86 or higher is recommended. **Never use an oil and gasoline mixture!**
3. **Air Cleaner:** Never run the engine without the air cleaner! Rapid engine wear will result from contaminants being drawn through the carburetor and into the engine.
4. **Engine Starting:** Refer to the engine owner's manual additional proper engine starting procedure.

E. Pointer Alignment

1. Use a straight edge, and carefully mark a line 12 feet long on a smooth level surface.
2. Place the saw blade on the marked line, move the saw to the center of the marked line and then lower the blade until it is about 1/16" above the marked line
3. Measure from each end of the saw frame to insure that the frame is parallel to the marked line. Adjust the saw as needed.
4. With the blade centered on the marked line and the saw frame parallel to the marked line, lower the front pointer.
5. Adjust the pointer by bending it until is aligned with the marked line.

II. OPERATION

A. Installing the Blade

1. Disconnect the spark plug.
2. Remove the blade shaft nut, (Turn clockwise), and remove the outside collar.

3. Clean off any foreign particles on the clamping surfaces of both collars and on the mounting surface of the blade.
4. Place the blade on the blade shaft, lining up the drive pin hole in the blade with the drive pinhole in the inside collar.



For Best Performance Use Only Norton Diamond Blades Specified For the Material Being Cut.

5. Slide the outside blade shaft collar onto the blade shaft. The drive pin on the outside collar must project through the drive pin hole in the blade and into the inside collar.
6. Tighten the blade shaft nut (counter-clockwise) securely against the outside collar.
7. Reconnect the spark plug.

B. Starting the Engine

1. Refer to the engine owner's manual for detail starting procedures.
2. Always cut with engine rpm in the full throttle setting.



Before starting, insure that the blade is properly installed, all guards are in place and in safe operating condition, and that the Blade is not in contact with any surface or object. Also verify that the area where the work is to be preformed is clean, safe, and has proper ventilation and lighting. Always located and properly mark all water, gas, and electrical services before beginning any work.

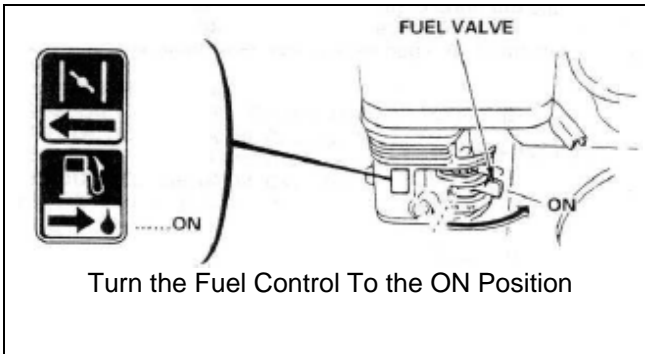

Turn the Fuel Control To the ON Position

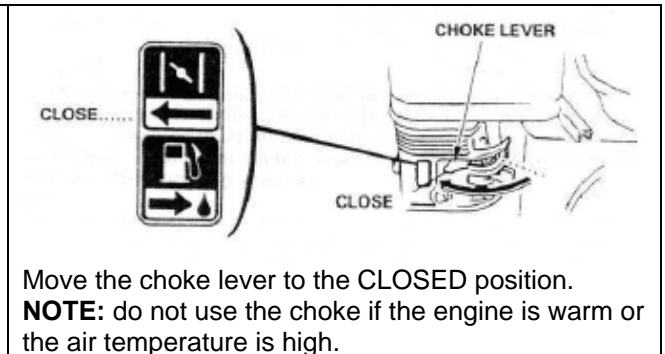

Move the choke lever to the CLOSED position.
NOTE: do not use the choke if the engine is warm or the air temperature is high.

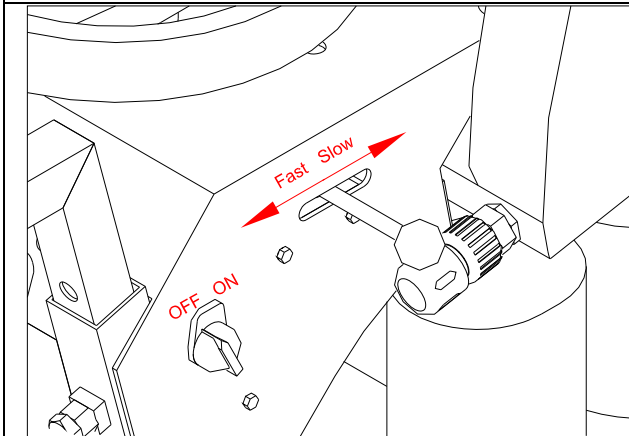

Pull The Throttle Control Slightly to the Rear to provide some engine throttle.

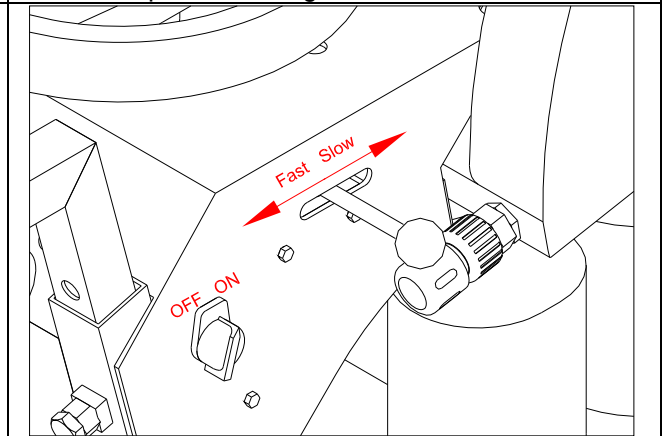

Place the engine ON/OFF switch to the ON position

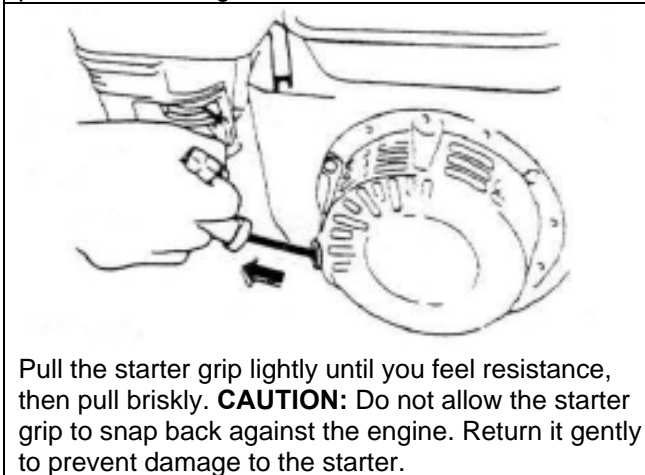

Pull the starter grip lightly until you feel resistance, then pull briskly. **CAUTION:** Do not allow the starter grip to snap back against the engine. Return it gently to prevent damage to the starter.

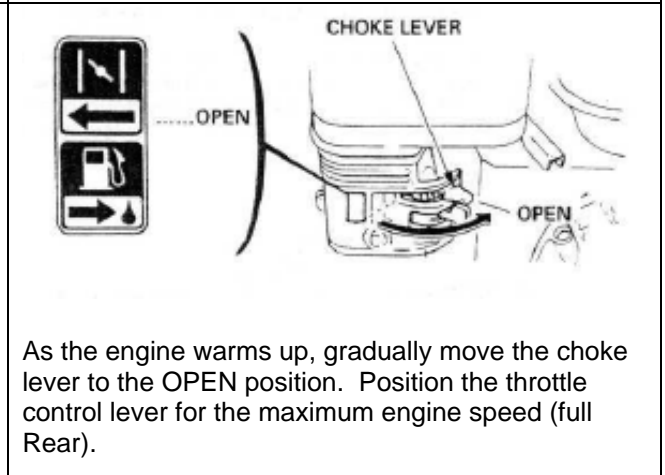

As the engine warms up, gradually move the choke lever to the OPEN position. Position the throttle control lever for the maximum engine speed (full Rear).

To stop the engine, move the Throttle Control Lever fully to the Forward Position (Slow) right, then turn the engine switch to the OFF position. Turn the fuel valve to the OFF position.



Never transport the machine with the Fuel Valve in the ON position. Never Store the machine with the Fuel Valve in the ON position. Never Transport a machine with the blade installed.

C. Water Supply

Pressurized source: Turn the water control to full "ON" when using wet cutting blades. The required flow rate is 4-6 gallons per minute.

Water Tank on saw: This supply is designed for use with dry blades to keep the dust levels down. The tank will not supply the proper water flow rates when used with wet cut only blades. Do not drink the water from this tank. Fill the tank with water only. Close the water tank valve. Attach the saws water supply hose to the tank outlet. Fill the tank with water. The capacity of the tank is 6.5 US Gallons (24.6 liter). When you are ready to cut, adjust the water supply rate until a fine mist or a slow trickle is made. The use of water greatly decreases the amount of dust produced during the cutting process, aids in the cooling of the blade, and provides additional stability.

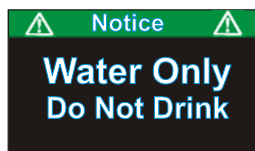

- Use Only Water In The Water Tank
- Do Not Drink From The Tank

D. Operating the Saw

1. For blade installation instructions **see section II. Operation sub heading A. Installing the Blade.** For the engine starting instructions, see the Engine manual and follow the instructions located in section II. **Operation sub heading B. Starting the Engine.**
2. Check the Engine Oil level.
3. Raise the saw to the full upright position. Do not let the blade come in contact with the ground.
4. Maneuver the saw to the desired starting point.
5. If wet cutting, connect the water supply to the saw.
6. Follow the instructions for starting the engine found in the Engine manual.
7. If wet cutting, turn on the water supply at the source and then open the water valves on the saw. Make sure that there is a minimum of 4-6 gallons per minute of water flow!!
8. Be sure the engine is running at full throttle!!!
9. Slowly lower the blade by rotating the hand wheel clockwise until the desired depth of cut is reached. Use a reasonable rate of feed. Do not force the blade into the cut!!

10. When the end of the cut is reached, slowly raise the blade out of the cut by rotating the Hand Wheel counter-clockwise until the blade is at least one (1) inch above the ground.
11. Only move the saw in reverse with the blade in the raised position.
13. When moving the saw to a new location, be sure the blade is not touching the ground. Always pay close attention to where you are moving and where the blade is at all times.

E. Cutting Technique

Lower the blade into the concrete to the required depth by turning the hand wheel clockwise.

Reduce the forward pressure if the saw begins to stall.

Note: For deeper cuts (4 inches or more), several cuts should be made in incremental steps of 1-1/2 to 2 inches until the desired depth of cut is reached.

Push the saw steadily forward using the front pointer as a guide. Exert enough forward pressure so that the engine begins to labor, but does not slow down. If the saw begins to stall, reduce the forward movement until full rpm is restored to the blade. If the saw stalls, raise the blade out of the cut before restarting. Avoid excessive side pressure or twisting of the blade in the cut.

Additional Guide Lines For Sawing:

- Understand and follow all of the instructions in this owner's manual.
- If wet cutting, turn on the water supply so that there is a minimum of 4-6 gallons per minute of water flow!!
- In critically hard aggregate, more than a single pass may be needed to cut the desired depth.
- If the saw stalls in the cut, immediately stop the forward speed and raise the blade out of the cut. If this is not done the belts can fail or the blade may be damaged.
- Go slowly with a new blade until it opens up, that is, until the diamonds can be seen and felt.

III. MAINTENANCE

A. Engine

Follow the below schedule for engine maintenance. NOTE: Check the Honda Engine manual that came with the engine for any changes to the maintenance schedule. If the charts have any differences, follow the chart in the Honda Engine Manual. The Norton does not warranty the engine. If any warranty or service of the engine is required contact your nearest Honda service center, or from the Internet: <http://www.honda-engines.com/home.htm>

Honda engine (refer to owner's manual for complete maintenance.)

MAINTENANCE SCHEDULE

ITEM	REGULAR SERVICE PERIOD	EACH USE	FIRST 20HRS	EVERY 50HRS	EVERY 100HRS	EVERY 300HRS	Refer to page	
	Perform at every indicated operating hour interval.							
Engine oil	Check level	○					3-2	
	Change		○		○			
Reduction gear oil	Check level	○					3-2	
	Change		○			○		
Air cleaner	Check	○					3-3	
	Clean			○ (1)				
Fuel strainer cup	Clean				○		3-7	
Spark plug	Check-Clean				○		3-6	
Valve clearance	Check-Adjust					○	3-5	
Combustion chamber and valves	Clean-Lap					○	9-3,4	
Fuel line	Check (Replace if necessary)	Every 2 years						3-8

NOTE: (1) Service more frequently when used in dusty areas.

Check the engine oil level before each use when the engine is cool and the engine is level. Add oil if the level is low. The oil level should be within the operating range (see the engine owner's manual for details).

Only use a high-detergent, premium quality motor oil certified to meet or exceed U.S. automobile manufacturer's requirements for Service Classification SG, SF/CC, CD. Motor oils will show the classification on the container. A SAE viscosity of 10W-30 is recommend by Honda for general, all temperature use. Please consult the below chart or contact your local Honda service center for the proper viscosity for your temperature range.

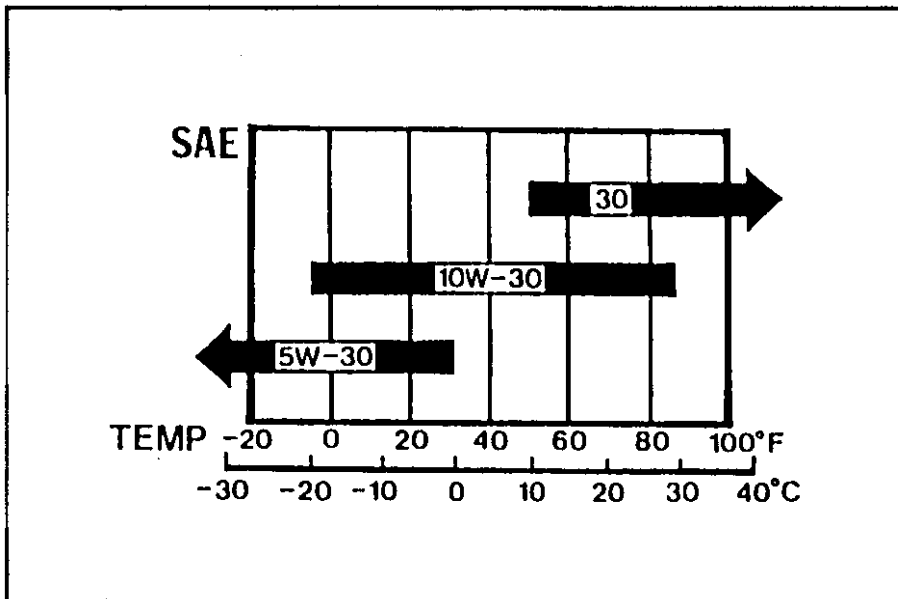

Always refer to the engine manual for more detailed information on checking the oil, changing oil, and oil capacity, air filter changes, and fuel type to use. Use only Honda air filters. Do not clean the air filter with gasoline or other flammable solvents. A fire or explosion could result. To clean, follow the instructions found in the Honda engine manual.

Dry Cutting Engine Maintenance

- When operating the engine in dry cutting or dusty environments the following is required:
- Engine oil changed more often.
- Every 50 hours (or more often if conditions require) clean all of the engine cooling fins.
- Every 25 hours (or more often if conditions require) clean the engine precleaner.
- Every 100 hours (or more often if conditions require) replace the air filter. If the engine is equipped with a reusable air cleaner, clean and re-oil it.
- Check and clean the air filter after each use. Replace as needed.

B. Bearings

Re lubrication type bearings must be relubricated **weekly** to assure long life. The grease used should conform to the NLGI grade two and be free of any chemical impurities such as free acid or free alkali, dust, rust, metal particles or abrasives.

For best results, bearings should be relubricated while in operation. **Note: Due caution for personal safety must be observed when servicing rotating equipment.** The grease should be pumped in slowly until a slight bead forms around the seals. This bead, in addition to acting as an indicator of adequate relubrication, provides additional protection against the entry of foreign matter. If necessary to relubricate while the bearing is idle refer to relubrication table for maximum grease capacity for the various size bearings.

Shaft Size	Maximum Grease Capacity of Bearing Chamber in Ounces
1/2" to 3/4"	1/8
7/8" to 1-3/16"	3/8
1-1/4" to 1-1/2"	5/8



Improper Maintenance Of Bearings Is Not Covered By Any Warranty. Over Lubrication Will Damage A Bearing. Grease Protruding From The Sides Of The Bearing Is A Sign Of Over Lubrication. Not Lubricating Bearings Will Damage The Bearing Unit. Damage Caused By Over or Under Lubricating Bearings Is Not Covered By Any Warranty.

C. V-Belts

Warning: Never make adjustments to belts or pulleys while engine is running!

The best tension for a belt drive is the lowest tension at which the belts will not slip under full load.

To adjust the C1318P Belt Tension:

The C1318P uses a simple single point tensioning system for the belt tensioning. The Belt Tensioning Assembly can be found behind the engine and is located in the center of the Frame. The Belt Tensioning Device is designed to pull or push the engine from the center which helps to reduce the Engine from twisting during the Belt Tensioning process. This new system is designed to be simple to install and to maintain with the tools equipped with the machine.



Insure that the Engine ON/OFF Switch is in the OFF position and that the Spark Plug is disconnected before making any adjustment to the Belt tension.

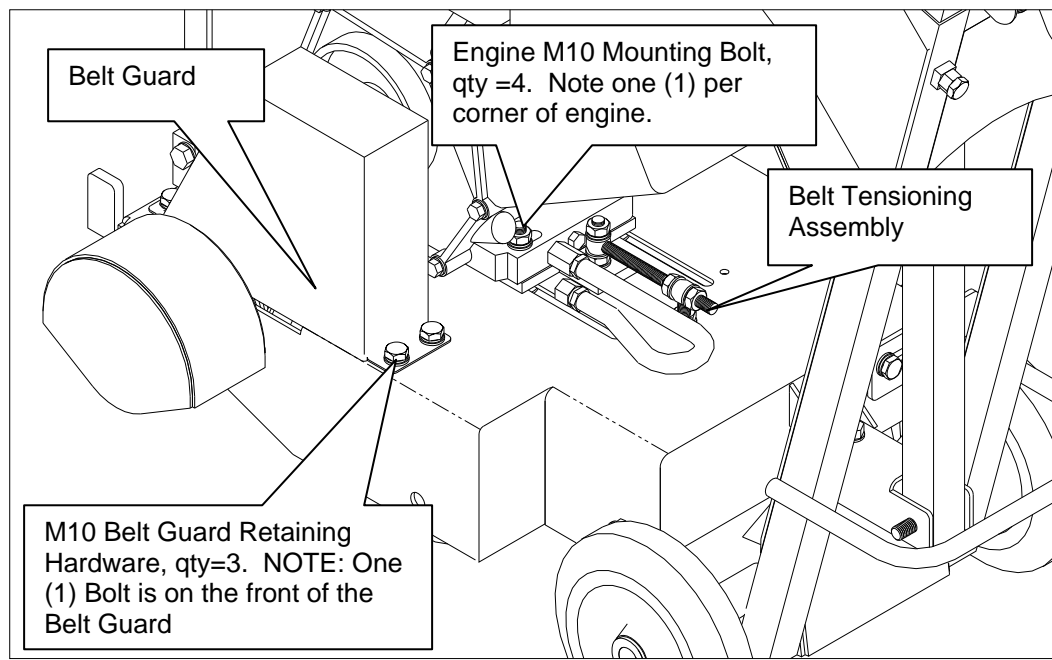

Figure: C1318P Belt Tensioning System

1. Review the locations of the C1318P Belt Tensioning system before proceeding. (See **Figure: C1318P Belt Tensioning System** on the previous page).
2. Remove the Belt Guard by loosening and removing the three M10 Belt Guard Retaining Bolts.
3. Check belt tension by pushing up or down at the center top span of the belt. The belt should move around 3/8" to 1/2" up and down. If adjustment is needed go to step 4. If no adjustment is required, replace belt guard and tighten all of the M10 Belt Guard Retaining Hardware.
4. Loosen the four (4) M10 Engine Mounting Bolts.
5. Loosen the two (2) M10 Jam Nuts on the C1318P Belt Tensioning Assembly (See **Figure: C1318P Belt Tensioning Assembly** below).

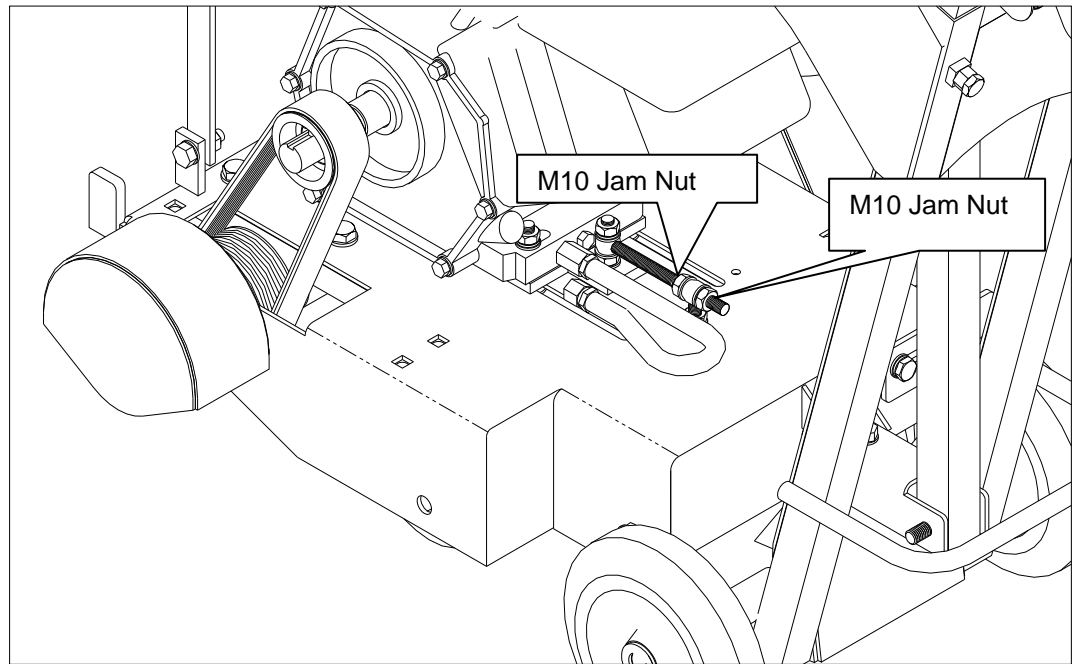

Figure: C1318P Belt Tensioning Assembly

6. To apply tension to the Belts tighten (turn clockwise) the rear M10 Jam Nut until the required Belt Tension is achieved. To loosen the Belts turn the front M10 Jam Nut counter clockwise until the required Belt Tension is achieved. (See **Figure: C1318P Belt Tensioning Jam Nut Directions**). NOTE: Do not over tighten the belts as too tight of belts can break Engine Output Shafts, Blade Shafts, Belts, and cause premature Bearing Failures. Failures due to too tight of Belts are not covered by any warranty. Too loose of Belts will cause the Belts to slip under load, and may cause burning of the Belts and is not covered under any warranty.

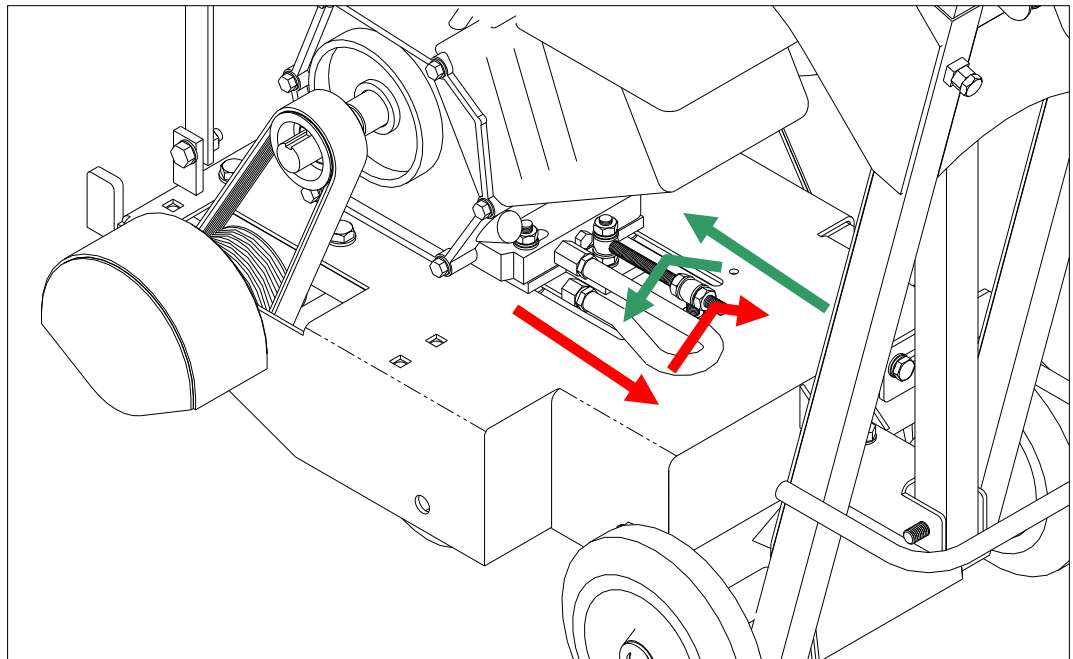

Figure: C1318P Belt Tensioning Jam Nut Directions

7. Tighten the four (4) M10 Engine Mounting Bolts.
8. Replace the Belt Guard and replace and tighten the M10 Belt Guard Retaining Hardware.
9. Run the machine for around 15 minutes and recheck the belt tension. If the Belts slip under load increase the belt tension.

Remember, too much tension shortens belt and bearing life!

Check the belt tension frequently during the first day of operation. Check the belt tension periodically thereafter and make any necessary adjustments.

To align the Pulleys:

1. Review the locations of the C1318P Belt Tensioning system before proceeding. (See **Figure: C1318P Belt Tensioning System** on page 15).
2. Remove the Belt Guard by loosening and removing the three M10 Belt Guard Retaining Bolts.
3. Line up a straight edge along the out side face of both pulleys. (See **Figure: Pulley Alignment** to the right.)
4. Misalignment will show up as a gap between the pulley face and the straight edge.
5. To correct the misalignment move one pulley in or out as required.

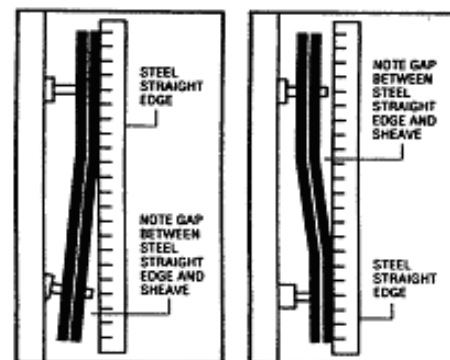

Figure: Pulley Alignment

Main Causes of Belt Failures:

Premature Belt failure can be attributed to the following issues: Tension (too much or too little), Pulley Misalignment, Damaged Pulleys, Improper Handling or Storage, Incorrect Blade Specification for Material Being Cut, and Cutting Too Deep.

Symptom	Possible Cause	Corrective Action
Belt Breakage	Too Much Tension	Re-tension Belts
	Excessive Shock Load	Reduce Load/ Check Blade Specification
	Pulley Out Of Round	Replace Pulley
Burning of Belt	Too Little Belt Tension	Increase Belt Tension
	Excessive Load (Cutting Full Depth)	For Best Performance Only Cut only 1-1/2" to 2" Per Pass
	Containments On Belts	Replace Belts and Find Source Of Containments
	Incorrect Blade Specification	Replace Blade With One Designed For Material Being Cut

Belt Failure Table Continued From Previous Page

Symptom	Possible Cause	Corrective Action
Belt Tearing/Ripping	Pulley Misalignment	Align Pulleys
Belt Rolling Off Pulley	Pulley Misalignment	Align Pulleys
Belt Cracking	Extremely Low Temperature at Startup	Warm Machine Before Use
	Exposure To Chemicals or Lubricates	Locate Source of Containments and Replace Belts.



Belts are a normal wear item and are not covered under warranty.

D. Depth Control

The depth control (raising screw) consists of a threaded rod, which feeds into a steel nut. In order to keep the two parts working smoothly it is necessary to keep the rod free from dirt and sludge as much as possible. Cleaning the threaded rod with a rag after each use will prevent sludge from collecting in the tube assembly and protect the threads. It is a good practice to keep the raising screw threads lubricated, as the slurry generated during cutting will cause premature thread wear.

The bearing used to support the raising screw should be checked after each use to make sure it is turning freely and lubricated. If the bearing requires re lubrication lithium base grease is recommended.

F. Inspections and Cleaning

For long life and better machine performance follow the inspection and cleaning schedule below.

		Regular Service Period Performed At Every Indicated Period →						
		After First Hour of Work	Beginning Of Day	During Blade Change	End Of Day	Once A Week	After Failure	After Damage
Whole Machine	Inspect For Damaged or Missing Components	X	X			X	X	X
	Clean		X			X		
Blade Collars	Clean			X				
Belt Tension	Check	X				X	X	X
Water Hose, Water Fittings, and Nozzles	Clean		X			X		
	Inspect		X			X		X
Depth Screw	Grease					X		
Engine	Clean					X		
Reachable Hardware	Tighten					X		
Bearings (Blade Shaft and Depth Control)	Grease*					X		
Wheels	Inspect	X	X			X		
Handle Bar Vibration Reduction System	Inspect	X	X			X	X	X

* = See Bearing Maintenance of This Manual Before Greasing



Replace any damaged or missing components before using machine.

IV. PARTS LIST SECTION

A. Ordering Information

1. List model number and serial number of machine from the Machine's Serial Number Plate.
2. List part number, UPC number, and Description of part DO NOT use the item number.
3. Wherever alternate parts are shown due to product improvement, inspect the part you have and provide additional description as necessary.
4. Specify mode of shipping desired, such as, parcel post, truck, U.P.S., best way, etc.

For the nearest Norton Clipper distributor call **254-918-2310**

Common Replacement Parts

Description	Part Number	UPC
BELT Poly-V 10 PK 698MM	232344	70184643371
Blade Shaft Nut $\frac{3}{4}$ -16 Left Hand Thread (Operators Right Side Of Saw)	227156	70184673903
Blade Shaft Nut $\frac{3}{4}$ -16 Right Hand Thread (Operators Left Side Of Saw)	227191	70184674346
Collar Tight (Operators Right Side)	227159	70184673904
Collar Tight (Operators Left Side)	227190	70184674352
Collar Loose Assembly (With Pin)	227247	70184674082
Drive Pin \varnothing 3/8 x 1	227154	70184674556
Water Tank Complete C1318P/CS451	232356	00310351798
Bearing Blade Shaft W/Hardware (1)	72474	00310004295
Front Wheel Complete W/Hardware (1)	82786	00310006552
Rear Wheel (1)	80991	00310005495
Wrench 1-1/2"	105377	70184649317
Wrench 32mm	82910	70184681049
Wrench 17mm	72279	70184655806

NOTE: All Parts Are Sold As Individual (each) Unless Noted Otherwise

Blades Use Only Clipper Diamond Blades. Contact your local Norton Clipper Distributor or our Customer Service at 254-918-2310 for the best blade for the application.

All parts are designated as either Service Parts (S) or Wear Parts (W) in the Type column in the parts listing. Wear parts are worn out through normal use of the machine. The wear period depends on the intensity of use of the machine, handling, and maintenance of the machine. Wear parts must be serviced and eventually changed following the indications of the manufacturer. Any wear due to normal use of the machine will not be considered as a case of warranty for items designated as Wear Parts (W). For best performance and life Genuine Norton Clipper replacement parts should always be used. Changes to part specifications, are subject to change with out notice.

Depth Control and Depth Lock Group

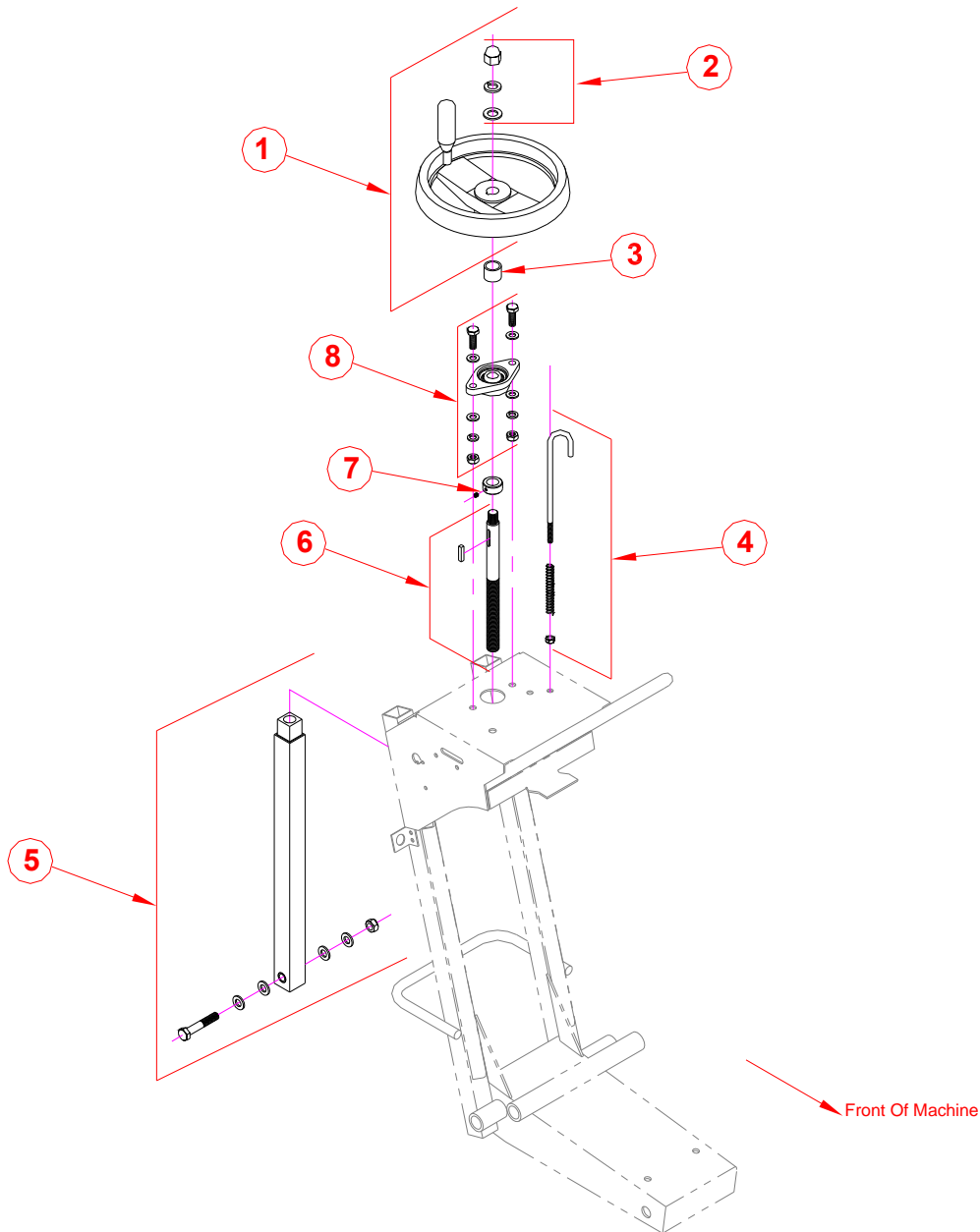

Item	Part No	UPC No	Description	QTY	Type	NOTES
1	076465	00310002163	HANDWHEEL AND HANDLE	1	S	Includes: Handle and Hardware
2	076843	00310004966	NUT HANDWHEEL	1	S	Includes: Acorn Nut, and Washers
3	048620	70184643370	SPACER 28x22x22	1	S	
4	232349	00310327609	WHEEL HOOK + SPRING CS 501	1	S	Includes: Hook, Spring, and Nut
5	082787	00310006553	TUBE DEPTH CTRL W/HARDWARE	1	S	Includes: Depth Tube and Hardware
6	082788	00310006554	RAISE SCREW C13/C13P18/C1318P	1	S	Includes: Raise Screw and Key
7	082789	00310006555	RING STOP DEPTH CONTROL	1	S	Includes: Set Collar and Set Screw
8	076670	00310004907	BEARING FLG KIT DEPTH CONTROL	1	W	Includes: Bearing and Hardware

Type: S = Service Part, W = Wear Part, All Parts Are Sold As Individual (each) Unless Noted Otherwise

Handle Bar Group

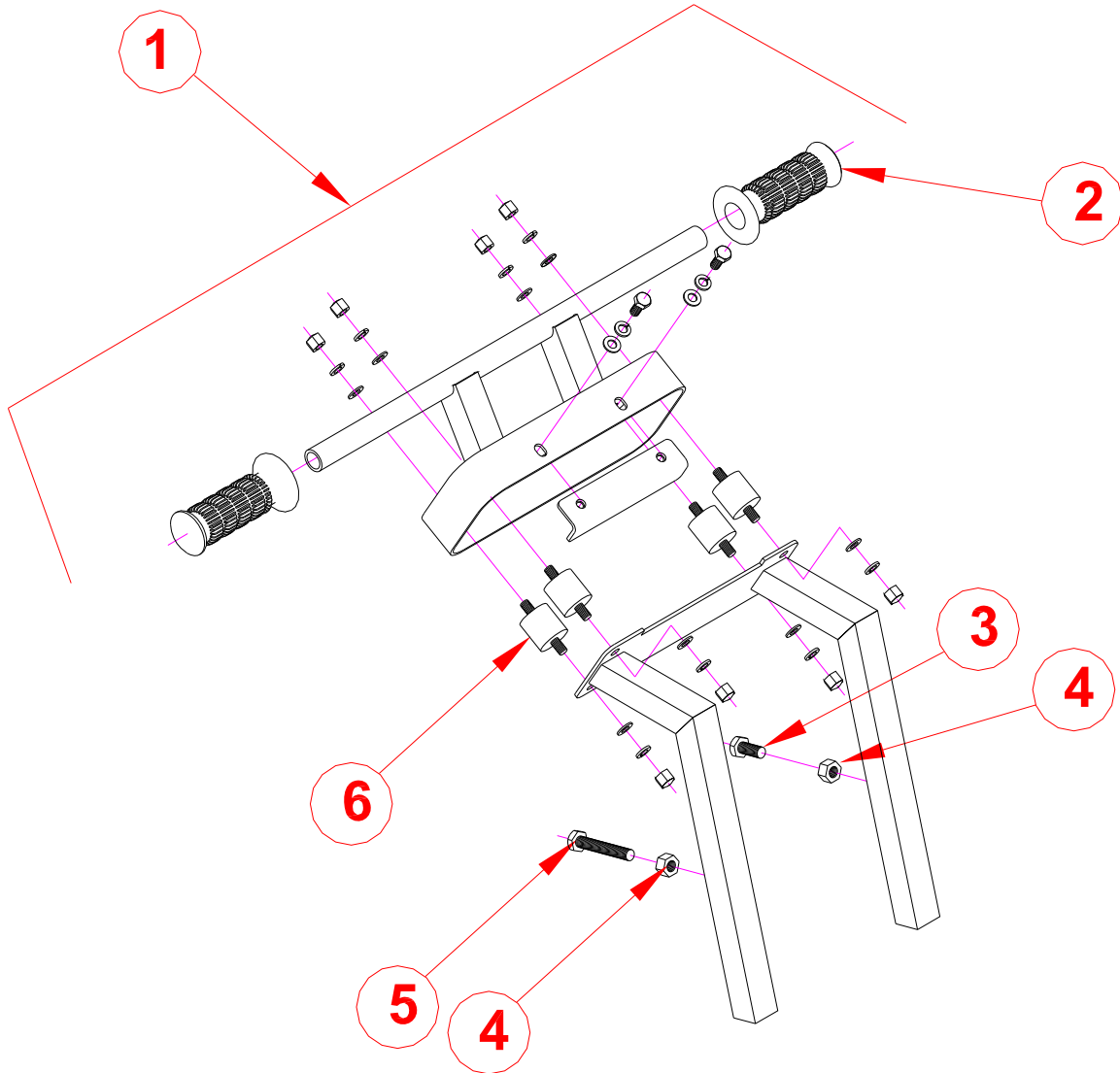

Item	Part No	UPC No	Description	QTY	Type	NOTES
1	232313	70184643284	HANDLE BAR ASSEMBLY C1318P	1	S	Includes: Handle Bar Frame (Upper and Lower), Hand Grips (2), Vibration Absorber Kit (4), and Hardware
2	072097	00310004190	GRIP HANDLE	2	S	Sold As Each. Appearance May Vary
3	027021	70184600809	SCR M10 X 25 8.8 DIN933	1	S	
4	027006	70184681615	NUT M10 1.5 DIN934	2	S	
5	232368	70184643256	SCR M10 X 70 1.5 DIN933	1	S	
6	232350	00310353381	VIBRATION ABSORBER KIT (4) C1318P	1	W	Includes: Set of Four (4) Silent Bock and Mounting Hardware

Type: S = Service Part, W = Wear Part, All Parts Are Sold As Individual (each) Unless Noted Otherwise

NOTE: In order for the Vibration Reduction System to function properly the Acorn Nuts towards the operator are torque to 0.27 lb-feet (4Nm). The Acorn Nuts on the bottom of the handle bars are fully tightened. Over tightening of the Operator Size Acorn Nuts will prevent the Vibration Reduction System from functioning.

Blade Guard Group

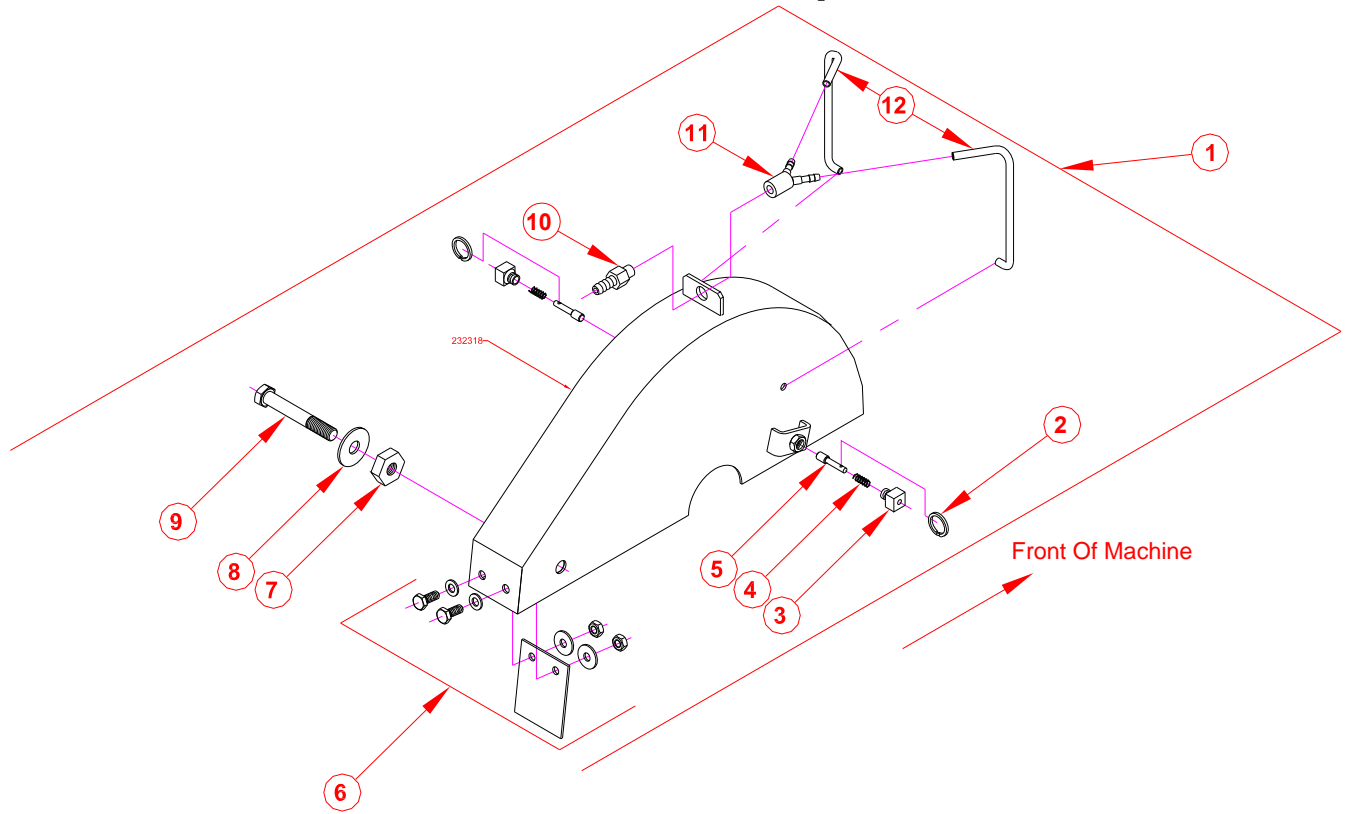

Item	Part No	UPC No	Description	QTY	Type	NOTES
1	232317	70184643285	BLADE GUARD ASSEMBLY C1318P	1	S	Includes: Items 2 (2x), 3 (2x), 4 (2x), 5 (2x), 6, 7, 8, and 9
2	238222	70184628500	PIN GUARD LOCK	2	S	
3	238223	70184628501	RING GUARD LOCK	2	S	
4	238224	70184628499	SPRING GUARD LOCK	2	W	
5	238225	70184628498	GUARD LOCK	2	S	
6	082800	00310006566	GUARD SPLASH KIT	1	W	Includes: Splash Guard and Hardware
7	083366	00310007020	NUT HEX M15 X 38MM	1	S	
8	232351	70184643255	WASHER M16 FENDER DIN9021	1	S	
9	083367	00310007021	BOLT BLADE GUARD	1	S	
10	9600010	70184650463	FIT BARB HOSE 1/4MPTX3/8	1	S	
11	072286	00310004233	FIT HOSE Y	1	S	
12	082998	70184681299	NOZZEL WATER (2) C13/C1318P/C1318P/C13E/C9E	1	S	Set of two (2) Nozzles

Type: S = Service Part, W = Wear Part, All Parts Are Sold As Individual (each) Unless Noted Otherwise

Blade Shaft Group

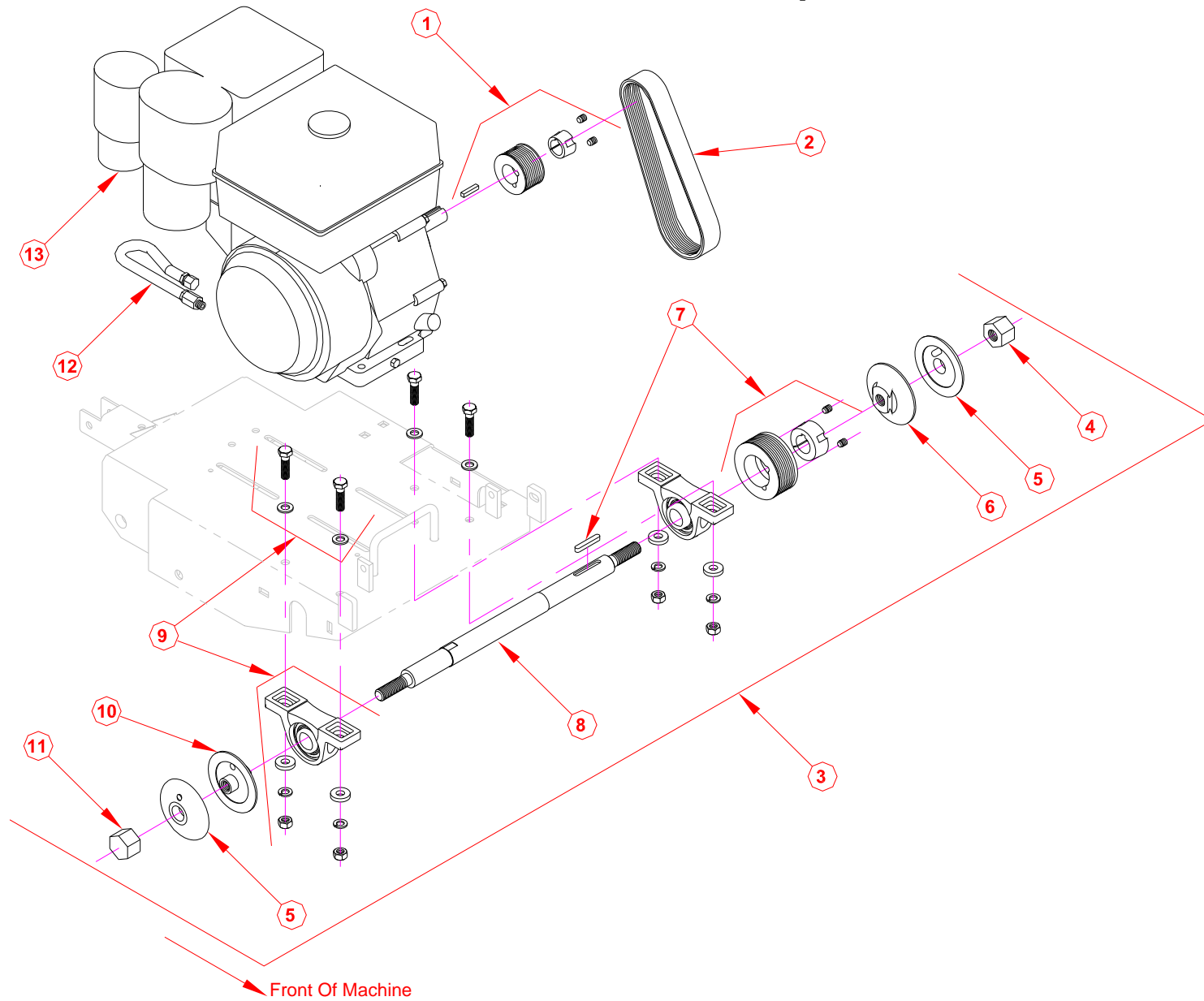

Blade Shaft Group

Item	Part No	UPC No	Description	QTY	Type	NOTES
1	232352	70184643291	PULLEY ENGINE KIT C1318P	1	S	Includes: Pulley, Bushing, Set Screws, and Key
2	232344	70184643371	BELT POLY-V 10 PK 698MM	1	W	
3	232357	70184643372	SHAFT BLADE ASSEMBLY C1318P	1	S	Includes: Items 4, 5 (2x), 6, 7, 8, 9 (2x), 10, and 11 NOTE: Does Not Include Belt
4	227156	70184673903	NUT BLADE SHAFT 3/4-16 LH	1	S	Operator's Left Side - Right Hand Thread
5	227247	70184674082	ASSY OUTER FLANGE (LOOSE)	2	S	Includes: Collar and Drive Pin
-NA-	227154	70184674556	PIN DRIVE (GROOVED) 3/8X1	2	W	
6	227190	70184674352	COLLAR TIGHT LEFT SIDE RH	1	S	Operator's Left Side - Right Hand Thread
7	232353	70184643373	PULLEY BLADE SHAFT KIT C1318P	1	S	Includes: Pulley, Bushing, Set Screws, and Key
8	083421	00310007070	BLADE SHAFT C13P18/C1318P	1	S	Blade Shaft Only
9	072474	00310004295	BEARING BLADE SHAFT (1) W/HARDWARE	2	W	Includes: One (1) Bearing, and Hardware
10	227159	70184673904	COLLAR TIGHT RIGHT SIDE LH	1	S	Operator's Right Side - Left Hand Thread
11	227156	70184673903	NUT BLADE SHAFT 3/4-16 LH	1	S	Operator's Right Side - Left Hand Thread
12	238057	70184628179	OIL DRAIN HOSE ASSY 13HP HONDA	1	S	
13	123327	70184671620	ENG 13HP HONDA GX390K1QXC9	1	S	Engine Only
N/A	123328	70184676096	AIR FILTER HONDA 11-13HP	1	W	

Type: S = Service Part, W = Wear Part, All Parts Are Sold As Individual (each) Unless Noted Otherwise

Belt Tensioning Group

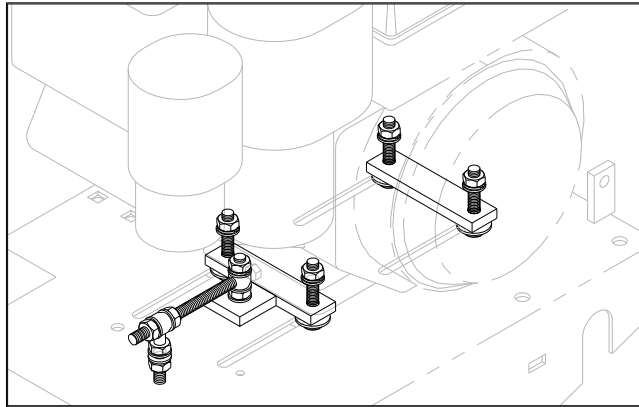

232330 Componets Assembled To C1318P

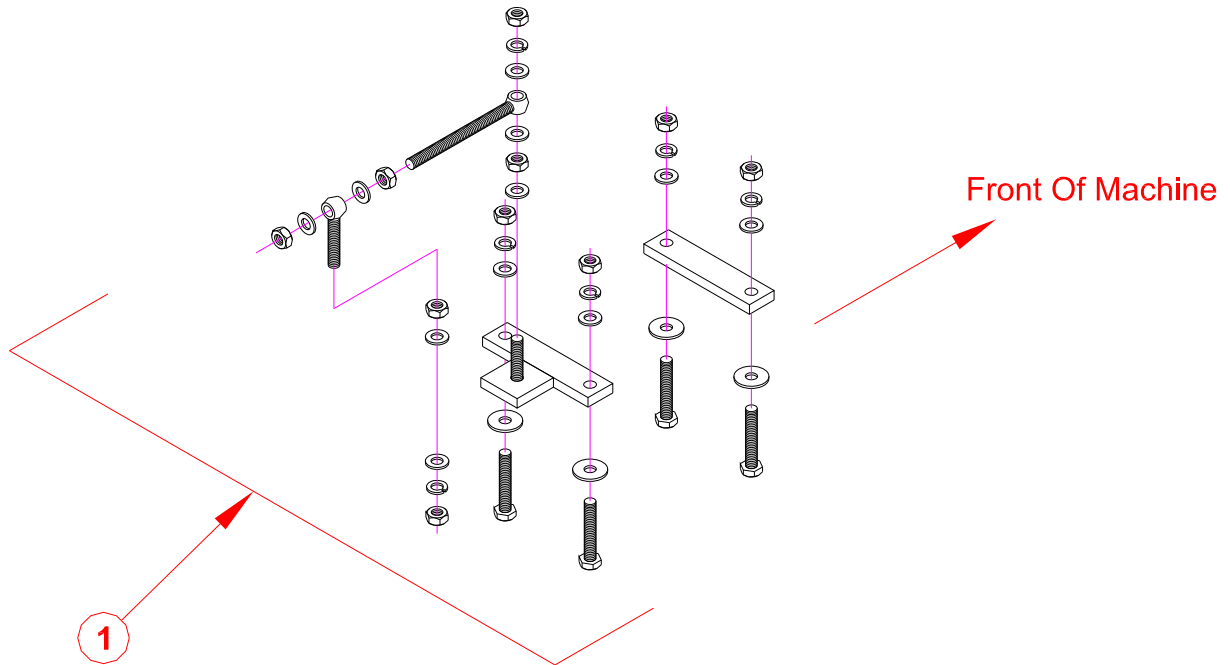

Item	Part No	UPC No	Description	QTY	Type	NOTES
1	232330	70184643374	ENGINE MOUNTING KIT W/HARDWARE C1318P	1	S	Includes: Front, Rear Motor Mounts, and Hardware

Type: S = Service Part, W = Wear Part, All Parts Are Sold As Individual (each) Unless Noted Otherwise

Engine Mount Group

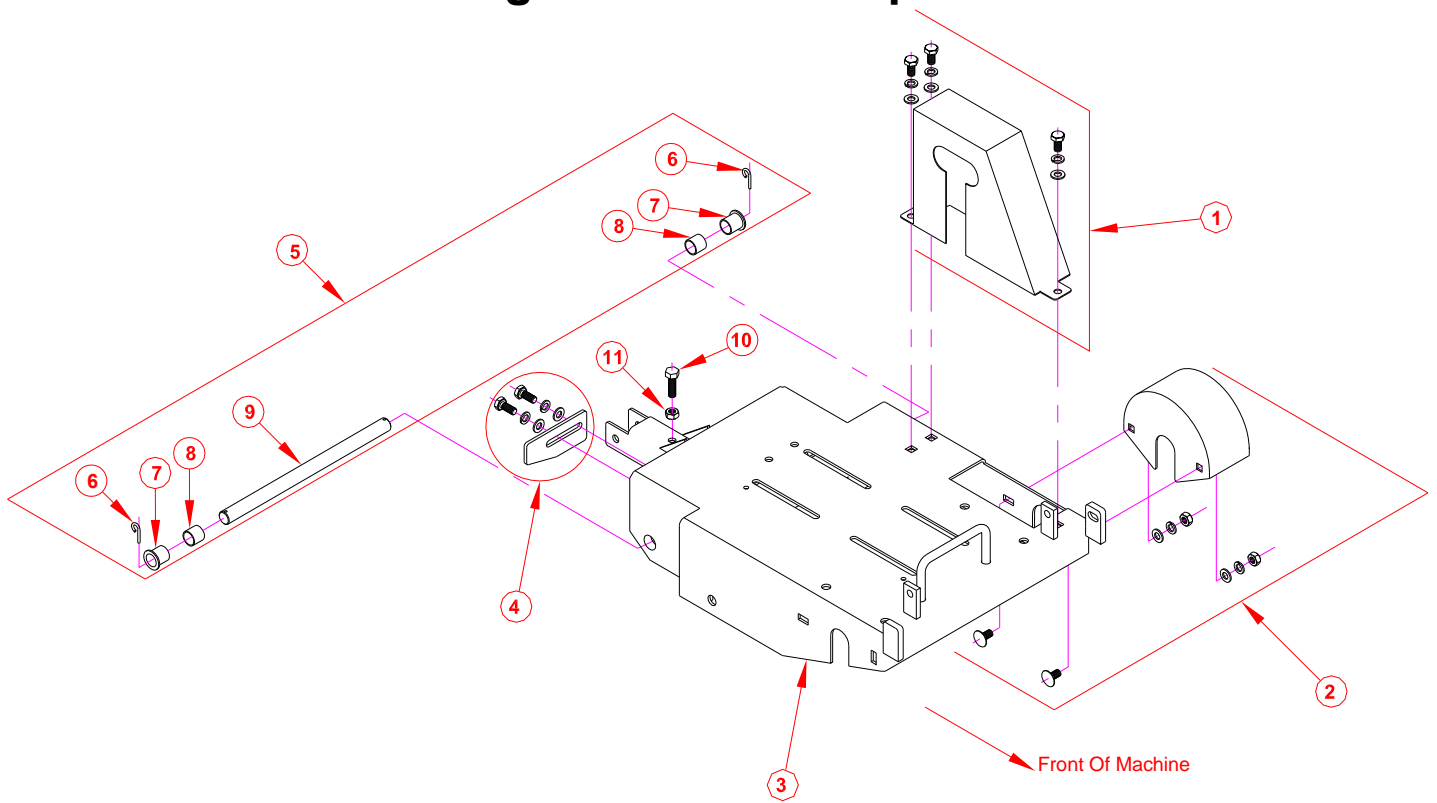

Item	Part No	UPC No	Description	QTY	Type	NOTES
1	083371	00310007025	GUARD BELT ASSY	1	S	Includes: Belt Guard and Hardware
2	232358	70184643375	BLADE SHAFT GUARD ASSMEBLY C1318	1	S	Includes: Blade Shaft Guard and Hardware
3	083369	00310007023	FRAME WELD MOTOR C13P18/C1318P	1	S	Includes: Engine Mount Only
4	082804	00310006570	BRAKE KIT REAR WHEEL C13P18/C1318P	1	S	Includes: Break and Hardware
5	082802	00310006568	PIVOT MOTOR & FRAME KIT	1	W	Includes Items: 6 (2x), 7 (2x), 8 (2x). 9 (2x)
6	227146	70184674553	PIN COTTER 1/8 X 1-1/2	2	W	
7	080999	00310005502	BUSH OUTR MOT PIVOT (1)	2	W	
8	080297	00310005129	BUSH INNR MOT PIVOT (2)	2	W	Sold In Set Of Two (2)
9	082803	00310006569	PIVOT MOTOR & FRAME	1	S	Engine Mount Pivot Shaft Only
10	27030A	70184681620	SCR M10 X 35 1.5 DIN933	1	S	
11	27006	70184681615	NUT M10 1.5 DIN934	1	S	

Type: S = Service Part, W = Wear Part, All Parts Are Sold As Individual (each) Unless Noted Otherwise

Main Frame Group

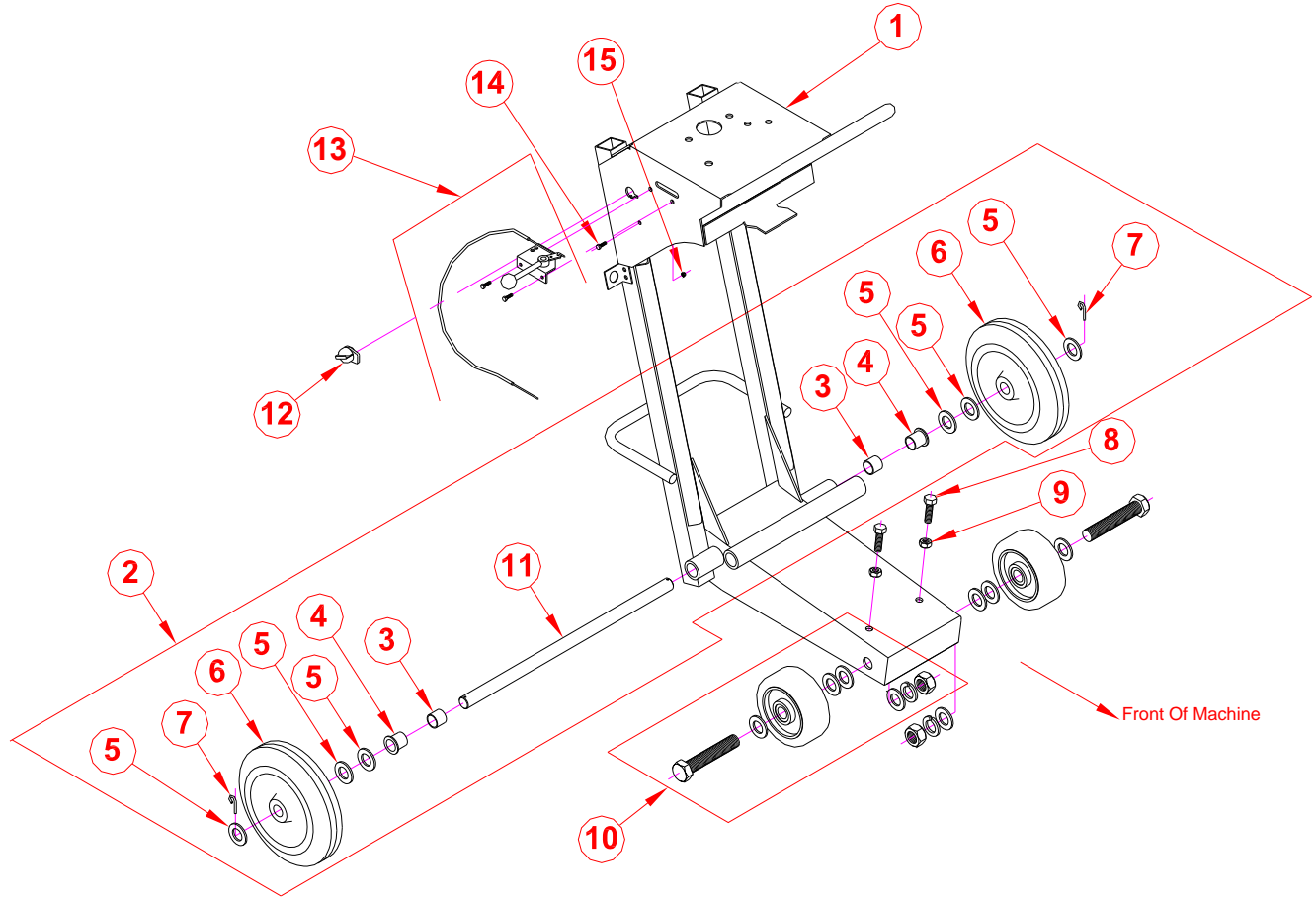

Item	Part No	UPC No	Description	QTY	Type	NOTES
1	232323	70184643376	MAIN FRAME WELDMNT C318P	1	S	Frame Only
2	082784	00310006550	AXLE REAR COMPLT W/WHEELS	1	S	Includes Items: 3 (2x), 4 (2x), 5 (6x), 6 (2x), 7 (2x), and 11
3	080297	00310005129	BUSH INNR MOT PIVOT (2)	2	W	Sold In Set Of Two (2)
4	080999	00310005502	BUSH OUTR MOT PIVOT (1) C	4	W	
5	27504B	70184681623	WASHER M20 DIN125 FLAT	6	S	
6	080991	00310005495	WHEEL 200X50X100 (20mm Bore) REAR	2	W	
7	227146	70184674553	PIN COTTER 1/8 X 1-1/2	1	W	
8	27030A	70184681620	SCR M10 X 35 1.5 DIN933	2	S	
9	27006	70184681615	NUT M10 1.5 DIN934	2	S	
10	082786	00310006552	WHEEL FRONT KIT 125/50/20	2	W	Includes: Wheel and Hardware
11	082785	00310006551	AXLE REAR ONLY C13/C13P18/C1318P	1	S	
12	227115	70184674394	SWITCH ENGINE ON/OFF HONDA	1	W	Sold as Each For GX390K1QXC
13	232124	00310024052	THROTTLE ASSEMBLY C13P18/C1318P	1	W	Includes: Throttle Control, Control Cable, and Hardware
14	224237	70184665412	SCR M6 X 20 1.0 DIN933	1	S	
15	300833	70184625661	NUT M6 1.0 DIN934 HEX	1	S	

Type: S = Service Part, W = Wear Part, All Parts Are Sold As Individual (each) Unless Noted Otherwise

Water Control Group

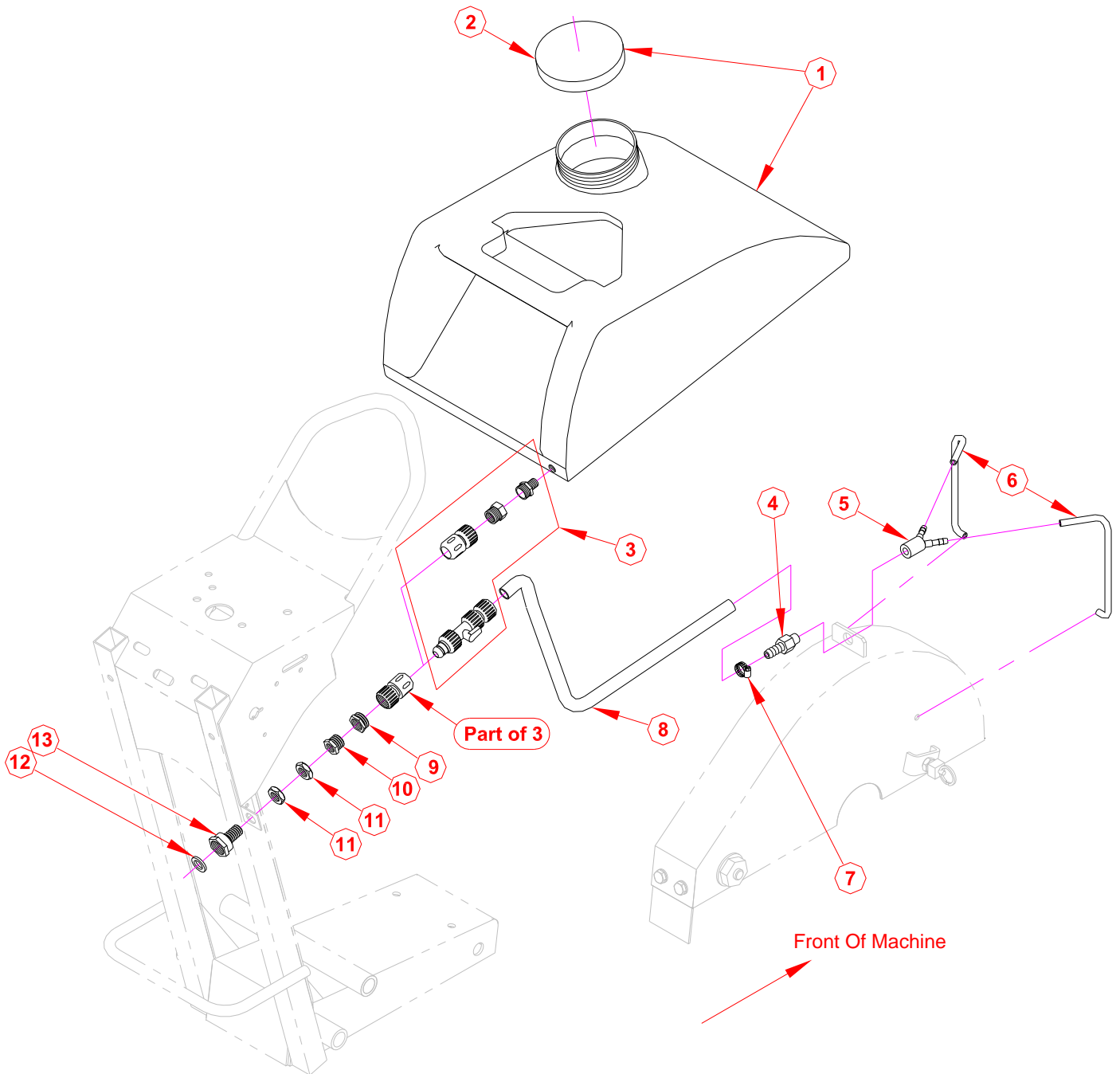

Water Control Group

Item	Part No	UPC No	Description	QTY	Type	NOTES
1	232356	00310351798	WATER TANK COMPLETE C1318P/CS451	1	S	Includes: Water Tank and Stopper (Cap)
2	082794	00310006560	STOPPER WATER TANK C13/C13P18/C1318P	1	S	
3	232121	00310024053	VALVE & CONNECTOR ASSY	1	S	Includes: Valve Assembly w/Hose Adapter (1), Male Quick Detach x 3/4" Garden Hose (1), Female Quick Detach (1) x 3/4" Garden Hose, Hex Bushing 3/4" Garden Hose x 1/2 FPT (1), and Reducing Bushing 1/2 MPT x 1/4MPT (1) NOTE: Valve Assembly w/ Hose Adapter, Male Quick Detach x 3/4" Garden Hose, and Female Quick Detach x 3/4" Garden Hose are not sold separately
4	9600010	70184650463	FIT BARB HOSE 1/4MPTX3/8	1	S	
5	072286	00310004233	FIT HOSE Y	1	S	
6	082998	70184681299	NOZZEL WATER (2) C13P18/C1318P	1	S	Set of two (2) Nozzles
7	227126	70184674516	CLAMP HOSE WORM 7/32"TO 5/8 x 5/16"W	1	S	
8	200195	70184627867	HOSE 3/8"ID X 1/2"OD X 48"LG	1	S	
9	238067	70184628020	REDUCER FIT 3/4MGH x 1/2FMPT	1	S	
10	232354	70184643377	BUSHING HEX 1/2MPT x 3/8 FPT	1	S	
11	232355	70184643378	NUT PIPE LOCK 3/8 BRASS	2	S	
12	101868	70184650620	WASHER HOSE 1.00OD X .625	1	W	
13	121273	70184650637	SWIVEL HOSE 3/8MPTX3/4GHT	1	S	Does Not Include Hose Washer

Type: S = Service Part, W = Wear Part, All Parts Are Sold As Individual (each) Unless Noted Otherwise

Front Pointer Group

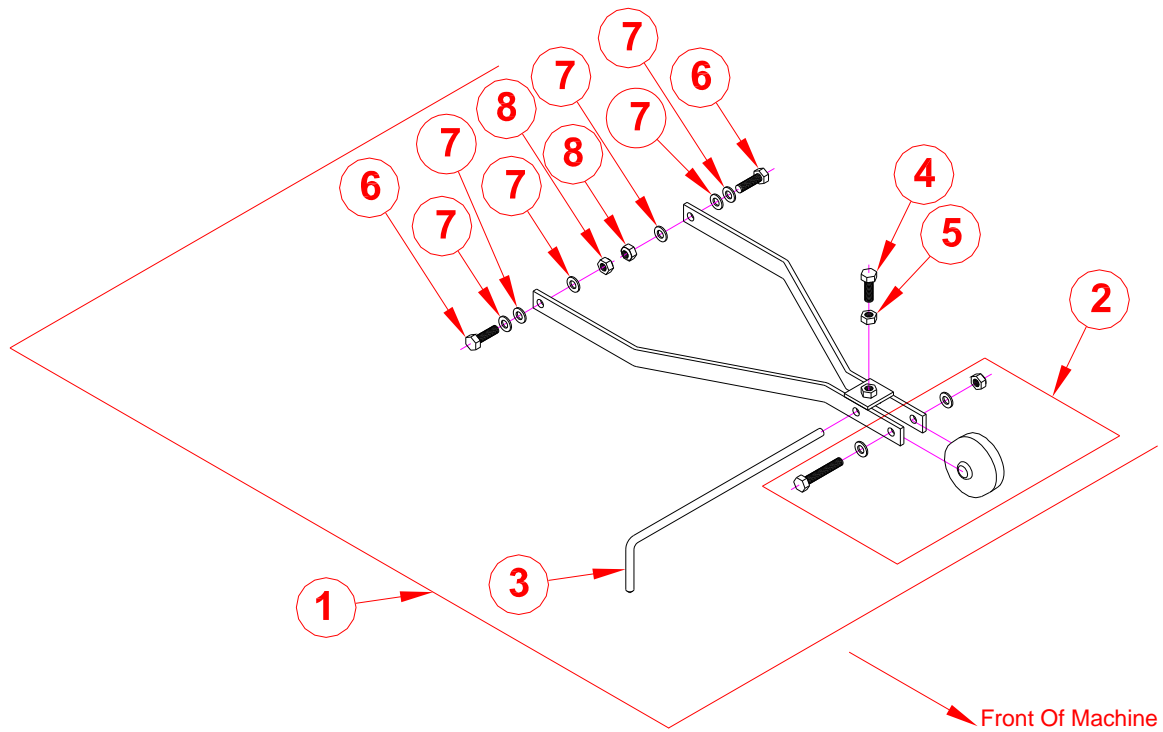

Item	Part No	UPC No	Description	QTY	Type	NOTES
1	232127	00310024051	POINTER ASSY C13PC18/C13P18/C1318P	1	S	Includes: Front Pointer Rod, Pointer Frame, Wheel, and Hardware
2	232126	00310004622	WHEEL POINTER W/HARDWARE C13P18/C1318P	1	S	Front Wheel and Hardware
3	232125	00310004244	POINTER ROD C13P18/C1318P/C13SP18	1	W	Front Pointer Rod Only
4	237242	70184627482	SCR M10 X 50 1.5 DIN933	1	S	Sold as Each
5	27006	70184681615	NUT M10 1.5 DIN934	1	S	Sold as Each
6	27030	70184681605	SCR M10 X 30 1.5 DIN933	2	S	Sold as Each
7	27504	70184681610	WASHER M10 DIN125	6	S	Sold as Each
8	239007	70184628215	NUT M10 1.5 DIN985 LOCK	2	S	Sold as Each

Type: S = Service Part, W = Wear Part, All Parts Are Sold As Individual (each) Unless Noted Otherwise

Saint-Gobain Abrasives

2770 West Washington

Stephenville, TX 76401

Phone: 254-918-2310

Fax: 254-918-2312

The Norton logo consists of the word "NORTON" in a bold, italicized, white sans-serif font, centered within a blue parallelogram shape that is wider at the top and tapers towards the bottom.

NORTON

SAINT-GOBAIN

WARNING

Some dust created by power sanding, sawing, grinding, drilling, and other construction activities contains chemicals known to cause cancer, birth defects or other reproductive harm. Some examples of these chemicals are:

- **Lead from lead-based paints,**
- **Crystalline silica from bricks and cement and other masonry products, and**
- **Arsenic and chromium from chemically-treated lumber.**

Your risk from these exposures varies, depending on how often you do this type of work. To reduce your exposure to these chemicals: work in a well ventilated area, and work with approved safety equipment, such as those dust masks that are specially designed to filter out microscopic particles.