



Operating Instructions & Service Parts Manual

COLD FRONT™

Atomized Cooling Fan

Model WACF-3037

#28900

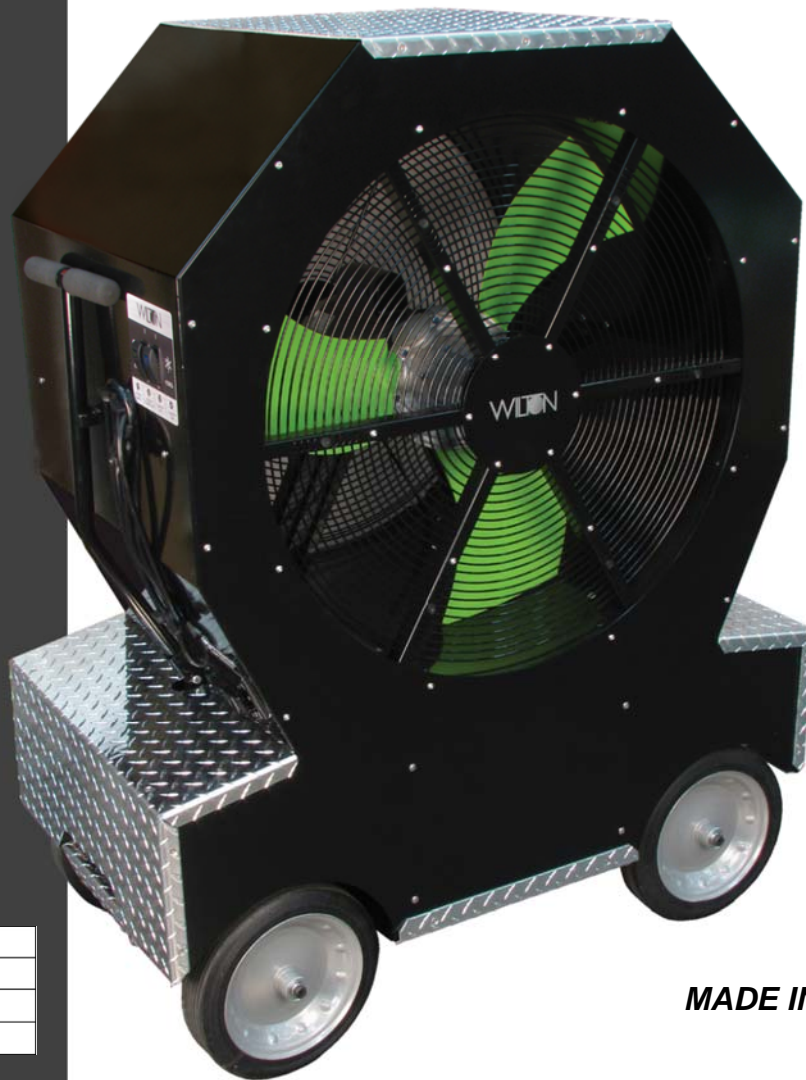

Stock No.:	
Serial No.:	
Purchased from:	
Date purchased:	



MADE IN THE U.S.A.

WILTON
 427 New Sanford Road
 LaVergne, Tennessee 37086
 Ph.: 800-274-6848
 www.wilontools.com

Manual No. M-28900
 Edition 5
 02/2018
 Copyright © 2018 WILTON



1.0 IMPORTANT SAFETY INSTRUCTIONS

WARNING – To reduce risk of fire, electric shock, or injury:

1. Read and understand all warnings posted on the machine and in this manual. Failure to comply with all of these warnings may cause serious injury.
2. Do not use this cooling fan for other than its intended use.
3. Replace warning labels if they become obscured or removed.
4. Keep ground or floor around the machine uncluttered and free of scrap material, oil and grease. Wear non-slip footwear.
5. Disconnect from power source before performing any maintenance or cleaning.
6. Do not unplug by pulling on cord. To unplug, grasp the plug, not the cord.
7. Have machine serviced only by qualified personnel, using authorized replacement parts.
8. Keep children away from area where Cooling Fan is being operated.
9. Do not pull this unit by the power cord, use cord as a handle, close a door on cord, or pull cord around sharp edges or corners. Keep cord away from heated surfaces.
10. Do not mount this fan to, or suspend it from, a wall or ceiling.
11. Do not stack fan units.
12. Do not allow any object to enter the screen guard and fan area during operation, as it may cause damage to machine and potential injury to bystanders.
13. Keep hair, loose clothing, fingers, and all parts of body away from openings and moving parts.
14. Do not obstruct the misting nozzles.
15. Unplug machine from outlet when not in use and before servicing.
16. Do not use this Cooling Fan in flammable or explosive environments, or around hazardous materials.
17. Do not store the Cooling Fan outdoors.
18. Do not use this unit with a damaged cord or plug. If the unit is not working as it should, has been dropped, damaged, left outdoors, or dropped into water, return it to a service center.
19. Do not stand on the machine. Serious injury could occur if the machine tips over.
20. Use wheel blocks in addition to applying the brake pedal when operating the unit on inclines or uneven terrain.

SAVE THESE INSTRUCTIONS

Familiarize yourself with the following safety notices used in this manual:



This means that if precautions are not heeded, it may result in minor injury and/or possible machine damage.



This means that if precautions are not heeded, it may result in serious, or possibly even fatal, injury.

2.0 Table of contents

Section	Page
1.0 IMPORTANT SAFETY INSTRUCTIONS	2
2.0 Table of contents.....	3
3.0 About this machine and manual.....	3
4.0 Specifications.....	4
5.0 Setup and operation.....	6
5.1 Shipping contents.....	6
5.2 Operation.....	6
5.3 Safeguards.....	6
5.4 GFCI test.....	6
6.0 Electrical connections	6
6.1 GROUNDING INSTRUCTIONS	6
6.2 Extension cords.....	7
7.0 User-maintenance.....	7
7.1 Tools required	7
7.2 General cleaning.....	7
7.3 Cleaning filters.....	8
7.4 Brake adjustment	8
7.5 Air pressure valve.....	8
7.6 Additional servicing	8
8.0 Troubleshooting Wilton WACF-3037 COLD FRONT™	9
9.0 Replacement Parts for WACF-3037 COLD FRONT™	10
10.0 Warranty and service	11

3.0 About this machine and manual

The WACF-3037 Wilton COLD FRONT™ is designed for areas more than 3,000 square feet. Its hydro-pneumatic system atomizes water into very fine particles which evaporate instantly in the high-velocity airstream, reducing the temperature of the expelled air to create an immediate cooling effect. The absence of conventional pads, and its micro-atomization of the water means lower risk of clogging and less need for maintenance. The low-pressure pump contributes to energy efficiency.

This manual covers operation and maintenance procedures for the Wilton COLD FRONT. It contains instructions on setup, safety precautions, general operating procedures, maintenance instructions and service parts information. Your machine has been designed and constructed to provide consistent, long-term operation if used in accordance with the instructions set forth in this document.

If there are questions or comments, please contact your local supplier or Wilton. Wilton can also be reached at our web site: www.wiltontools.com. Retain this manual for future reference. If the machine transfers ownership, the manual should accompany it.

Register your product using the mail-in card provided, or register online: <http://www.wiltontools.com>

⚠WARNING Read and understand the entire contents of this manual before attempting assembly or operation. Failure to comply may cause serious injury.

4.0 Specifications

Model	WACF-3037 COLD FRONT™
Stock number	28900
Fan motor	(UR,CSA), 0.5HP, single phase, 60Hz, 115VAC, 6.4A, 1100RPM, thermally protected
Air compressor	(UR-c/us), 330W, 115VAC, 60Hz, 3A
Water pump	(VDE, ETL, CQC), 25W, 120VAC, 60Hz, 0.208mA, protected by water tank float switch
Optimal air pressure	30 PSI (2 kg/cm ²)
Power draw	1200W, 120VAC, 60 Hz, 10A
Power cable	(UL) SJTW 3/C, 14AWG, 300V, 6'9" length, 120V plug installed
Auxiliary dual receptacle	120V with GFCI, 5A max. output
Fan speed	1100 RPM
Fan diameter	30 in. (76.2 cm)
Air velocity	20 mph (32 kph)
Air delivery	8462 CFM (14377 m ³ /hr)
Water tank capacity	19 gal. (71.9 L), 10 hrs. operation before refill
Wheels	Aluminum rims, rubber tires Ø12 in. x W 3in. (305 x 76 mm)
Main enclosure	16ga. galvanized steel, powder-coat finish, with 8ga. aluminum diamond plates
Chassis	11ga. steel
Overall dimensions LxWxH	45 x 24 x 56 in. (114 x 62 x 142 cm)
Net weight	335 lbs. (152 kg)

Table 1

L = length, W = width, H = height Ø = diameter

CFM = cubic foot per minute

PSI = pounds per square inch

GFCI = ground fault circuit interrupter

The specifications in this manual were current at time of publication, but because of our policy of continuous improvement, Wilton reserves the right to change specifications at any time and without prior notice, without incurring obligations.

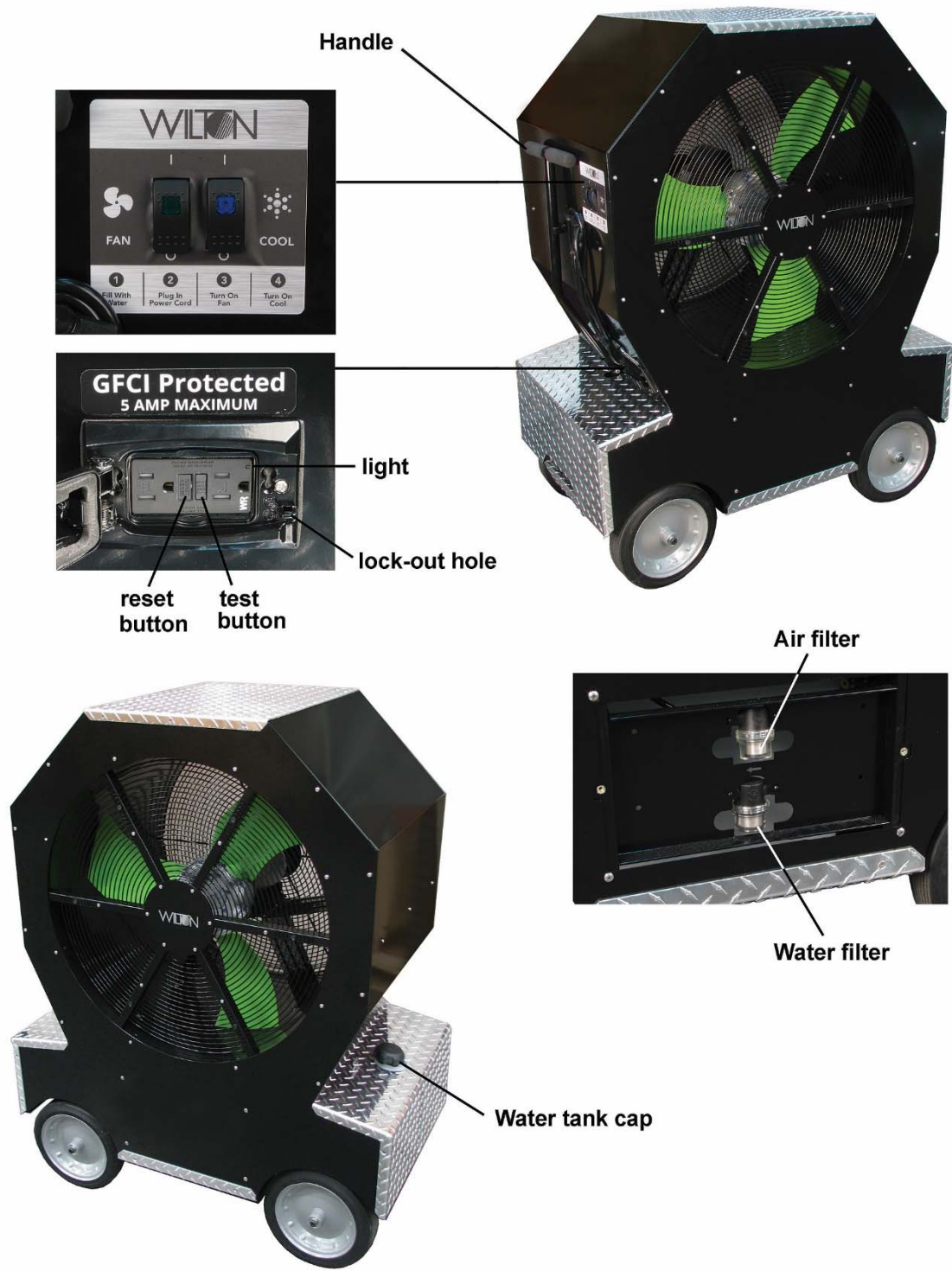

Figure 5-1

⚠WARNING Read and understand the entire contents of this manual before attempting to operate the Cooling Fan. Failure to comply may cause serious injury.

5.0 Setup and operation

No assembly is required for the Cooling Fan.

Remove Cooling Fan from shipping container and inspect it. If any shipping damage is discovered, immediately contact your dealer or Wilton at the phone number on the cover. Do not discard any shipping materials until Cooling Fan is set up and operating correctly.

5.1 Shipping contents

- 1 Cooling Fan
- 1 Instructions and parts manual
- 1 Product registration card

5.2 Operation

Refer to Figure 5-1.

1. Make sure tank drain plug is tight (located beneath chassis).
2. Unscrew tank cap, fill tank with clean, potable water, and reinstall cap.
3. Pull handle downward from clip, steer unit into position, then return handle to clip.
4. Push brake pedal all the way down to lock wheels in place. (Also use wheel blocks if on an incline or uneven terrain.) To release brake, place foot below pedal and push upward.
5. Connect the plug to the power source. **Make sure power source matches the electrical specifications of the Cooling Fan.** (When not in use, wrap the power cord around the provided holders.)
6. Press FAN switch to on (I) position to activate fan. Allow fan to run approximately 30 seconds, then press COOL switch to activate misting feature.
7. The COOL switch independently controls the misting system. Turn FAN switch off (O) to stop both fan and misting. Some misting may continue for a few moments during depressurization.

5.3 Safeguards

The fan motor has a thermal protector, which will automatically open the circuit (shut off machine) if the motor overheats. If this occurs, immediately turn off the switches, wait for unit to cool down, then use switches to restart.

CAUTION: If the switches are left on, the fan will start immediately once unit has cooled down sufficiently.

A float switch in the tank will shut off the air compressor and water pump if water level falls below threshold. Fill tank to continue operating.

5.4 GFCI test

1. Plug cord into power source. Green light on GFCI receptacle will illuminate.
2. Press FAN switch to on (I) position.
3. Press TEST button on GFCI. Light will go out and fan will stop working.
4. Press RESET button on GFCI. Light will illuminate and fan will restart.
5. The GFCI is functioning properly.

To prevent unauthorized access to GFCI receptacle, close cover and insert padlock (not provided) through lock-out holes.

6.0 Electrical connections

⚠WARNING All electrical connections must be done by a qualified electrician in compliance with all local codes and ordinances. Failure to comply may result in serious injury.

The Cooling Fan is rated at 115-volt power only, and is supplied with a plug designed for use on a circuit with a *grounded outlet* that looks like the one pictured in Figure 6-1.

Before connecting to power source, be sure switch is in *off* position.

It is recommended that the Cooling Fan be connected to a dedicated 15 amp circuit with circuit breaker or fuse. Local codes take precedence over recommendations.

6.1 GROUNDING INSTRUCTIONS

This machine must be grounded. In the event of a malfunction or breakdown, grounding provides a path of least resistance for electric current to reduce the risk of electric shock. This tool is equipped with an electric cord having an equipment-grounding conductor and a grounding plug. The plug must be plugged into a matching outlet that is properly installed and grounded in accordance with all local codes and ordinances.

Do not modify the plug provided - if it will not fit the outlet, have the proper outlet installed by a qualified electrician.

Improper connection of the equipment-grounding conductor can result in a risk of electric shock. The conductor with insulation having an outer surface that is green with or without yellow stripes is the equipment-grounding conductor.

If repair or replacement of the electric cord or plug is necessary, do not connect the equipment-grounding conductor to a live terminal.

⚠WARNING Check with a qualified electrician or service personnel if the grounding instructions are not completely understood, or if in doubt as to whether the tool is properly grounded. Failure to comply may cause serious or fatal injury.

Use only 3-wire extension cords that have 3-prong grounding plugs and 3-pole receptacles that accept the tool's plug.

Repair or replace damaged or worn cord immediately.

This machine is for use on a nominal 120-V circuit, and has a grounded plug that looks like the plug illustrated in sketch A in Figure 6-1. A temporary adaptor that looks like the adaptor illustrated in sketch B may be used to connect this plug to a 2-pole receptacle as shown in sketch B if a properly grounded outlet is not available. The temporary adaptor should be used only until a properly grounded outlet (sketch A) can be installed by a qualified electrician. The green colored rigid ear, lug, or the like extending from the adaptor must be connected to a permanent ground such as a properly grounded outlet box cover. Whenever the adaptor is used, it must be held in place by a metal screw.

In Canada, the use of a temporary adaptor is not permitted by the Canadian Electrical Code, C22.1.

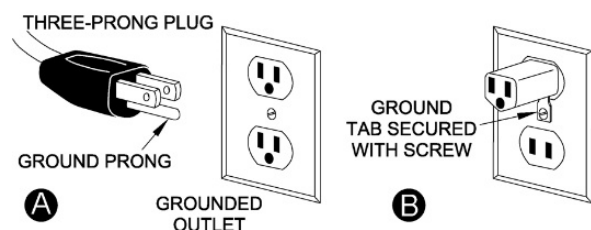

Figure 6-1

6.2 Extension cords

The use of extension cords is discouraged; try to position machines near the power source. If an extension cord is necessary, make sure it is in good condition. When using an extension cord, be sure to use one heavy enough to carry the current your product will draw. An undersized cord will cause a drop in line voltage resulting in loss of power and overheating. Table 2 shows correct size to use

depending on cord length and nameplate ampere rating. If in doubt, use the next heavier gauge. The smaller the gauge number, the heavier the cord.

Extension Cord Recommended Gauges (AWG)						
Amps	Extension cord length *					
	25 feet	50 feet	75 feet	100 feet	150 feet	200 feet
< 5	16	16	16	14	12	12
5 to 8	16	16	14	12	10	NR
8 to 12	14	14	12	10	NR	NR
12 to 15	12	12	10	10	NR	NR
15 to 20	10	10	10	NR	NR	NR
21 to 30	10	NR	NR	NR	NR	NR

*based on limiting the line voltage drop to 5V at 150% of the rated amperes.

NR = Not Recommended.

Table 2

7.0 User-maintenance

⚠WARNING Disconnect (unplug) from power source before performing any cleaning or maintenance of the unit, unless indicated otherwise.

7.1 Tools required

Cross-point (Phillips) screwdriver
T20 Torx head driver (for pan head screws)
T25 Torx head driver (for flat head screws)

7.2 General cleaning

- Do not use solvents or harsh chemicals on the cooling fan when cleaning.
- Keep air compressor fan housing clear of dust; blow out with compressed air if needed.
- Annually drain and clean water tank. Drain plug is located beneath tank – unscrew to remove.
- If cooled air produces musty or stale odor, drain water from tank. Place approximately 10 drops of unscented chlorine bleach into 2 gallons of clean water, and pour mixture into tank. Operate fan and misting system until air compressor and water pump shut off. Drain any remaining bleach mixture from the tank. Refill tank with clean water (no mixture) and operate normally.

NOTE: Undiluted vinegar may be used instead of bleach.

- If an individual nozzle is blocked, remove post (A, Figure 7-1), push blue rings (B) to pull out hoses, and remove entire nozzle unit (C). Soak nozzle unit in vinegar. Reinstall nozzle unit and test.

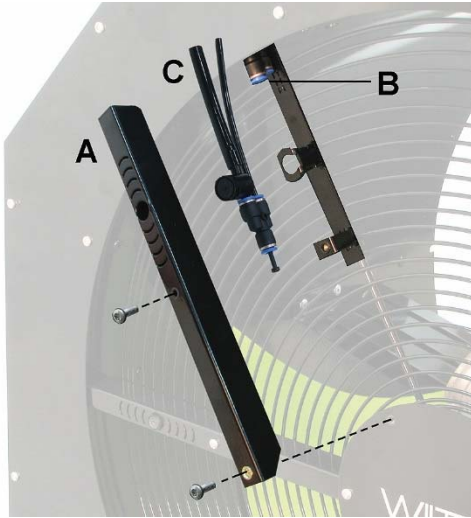

Figure 7-1

7.3 Cleaning filters

Inspect air and water filters annually (see Figure 5-1). Remove back panel to access them. Top filter is for air, bottom filter for water. Arrow on unit shows direction of flow.

Unscrew cup to remove filter mesh. Rinse any debris from mesh with clean water or vinegar. Reinsert mesh and reinstall cup onto filter body.

7.4 Brake adjustment

Brake function has been set by the manufacturer. If further adjustment is needed:

1. Remove lower end panel.
2. Loosen (do not remove) four hex cap screws (D, Figure 7-2).
3. Turn pan head screws (E) equally.
4. Retighten hex cap screws (D).

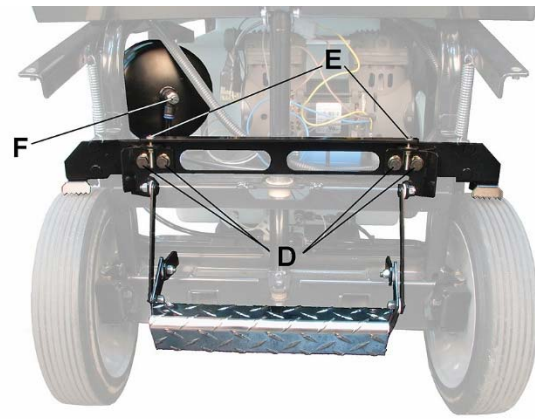

Figure 7-2

7.5 Air pressure valve

The (brass) pressure *release* valve at rear of air tank has been set by the manufacturer for the desired 30 PSI and should not require adjustment.

The pressure *output* valve at opposite end of air tank has been set by the manufacturer but can be adjusted by the user if needed. Loosen knurled nut and turn knob (F, Figure 7-2) to change setting. Tighten knurled nut to secure setting.

7.6 Additional servicing

Any additional servicing should be performed by authorized service personnel.

8.0 Troubleshooting Wilton WACF-3037 COLD FRONT™

Problem	Possible cause	Remedy *
Fan motor will not start.	No incoming current.	Check connections at plug or circuit panel.
	GFCI on machine has tripped.	Push RESET on GFCI receptacle.
	Low voltage.	Check power line for proper voltage.
	Open circuit in motor or loose connection.	Inspect switch and motor for loose or open connections.
	Faulty start switch.	Inspect and replace switch if needed.
	Faulty start capacitor.	Replace capacitor.
	Faulty motor.	Inspect and replace motor if needed.
Fan motor will not start: fuse blows or circuit breaker trips.	Too many machines on shared circuit.	Connect unit to dedicated circuit.
	GFCI on machine has tripped.	Push RESET on GFCI receptacle.
	Short circuit in line cord or plug.	Inspect cord or plug for damaged insulation and shorted wires.
	Short circuit in motor or loose connections.	Inspect all connections on motor for loose or shorted terminals or worn insulation.
	Incorrect fuse or circuit breaker in power line.	Install correct fuse or circuit breaker at power source.
Motor overheats.	Motor overloaded.	Allow to cool, then restart.
Thermal protector trips frequently.	Incorrect fuse or circuit breaker in power line.	Install correct fuse or circuit breaker at power source.
	Fan used for extended periods of time, motor overheats.	Allow to cool, then restart.
Loud noise or vibrations coming from machine.	Loose fasteners.	Inspect machine and tighten all fasteners.
	Fan is loose or imbalanced.	Inspect and tighten/repair.
Not cooling, or unsatisfactory misting effect.	Tank empty, float switch activated.	Fill with clean water.
	Water filter clogged.	Clean out filter.
	Nozzles obstructed.	Clean nozzles with weak acid solution, such as white vinegar. Inspect water system and hoses for impurities and blockages. Use clean water.
	Leak in water system.	Locate source of leak, replace seals.
	Water pump defective.	Inspect and replace if needed.
	Cooling switch defective.	Inspect and replace if needed.
Poor atomization of water, large droplets or nozzles streaming water.	Insufficient startup power provided to air compressor.	Turn fan on first and allow it to reach full speed, then turn on Cooling.
	Diminished air flow.	Run only fan for a short time, then turn on Cooling switch.
	Clogged air filter.	Clean out air filter.
	Nozzles or air hoses obstructed.	Clean nozzles with weak acid solution, such as white vinegar. Inspect air system and hoses for blockages. Use clean water.
	Cooling used for extended periods of time, air compressor overheats.	Allow to cool, then restart.
	Unstable power source, causing compressor to shut off while fan and water remain running.	Use stable power source.

***WARNING:** Some remedies may require a qualified electrician.

9.0 Replacement Parts for WACF-3037 COLD FRONT™

To order parts or reach the Wilton service department, call 1-800-274-6848 Monday through Friday, 8:00 a.m. to 5:00 p.m. CST. Having the Model Number and Serial Number of your machine available when you call will allow us to serve you quickly and accurately.

Non-proprietary parts, such as fasteners, can be found at local hardware stores or may be ordered from Wilton.

Part No.	Description
WACF-10101	FAN MOTOR (SINGLE SPEED, 0.5HP, 1100RPM)
WACF-10102	FAN BLADE ASSEMBLY (GREEN, SICKLE SHAPE)
WACF-10200	AIR COMPRESSOR (3.2 CFM, 35.5 PSI)
WACF-10301B	WATER PUMP (200 CC/MIN, 3.5 BAR, 120 VAC)
WACF-10401	WATER TANK (19 GAL)
WACF-10401D	DRAIN PLUG (FOR WATER TANK)
WACF-10401F	FILL CAP (FOR WATER TANK)
WACF-10402	FITTING, 6MM X 1/4 NPT
WACF-10403	LIQUID LEVEL SWITCH
WACF-10606	ACCESSORY OUTLET (GFCI PROTECTED)
WACF-10607	WEATHERPROOF COVER (FOR OUTLET)
WACF-10608	ROCKER SWITCH (GREEN, FOR FAN)
WACF-10609	ROCKER SWITCH (BLUE, FOR COOLING)
WACF-10703	POWER CORD WRAP KNOB
WACF-10801	FRONT FAN GUARD
WACF-10802	REAR FAN GUARD
WACF-10901	HANDLE GRIP
WACF-10903	GRIPPER CLIP (FOR STEERING HANDLE)
WACF-10904	WHEEL (12" DIA, SOLID TIRE)
WACF-11000A	AIR FILTER ASSEMBLY (8MM IN, 8MM OUT)
WACF-11000W	WATER FILTER ASSEMBLY (8MM IN, 6MM OUT)
WACF-11004	MESH STRAINER (40 MICRON, FOR FILTERS)
WACF-11005	CLEAR BOWL (FOR FILTERS)
WACF-11100	NOZZLE ASSEMBLY
WACF-20110	WHEEL BOLT (0.5" DIA, 3.5" LONG)
WACF-20121	SCREW, 10-24 x 0.75", T25 PAN HEAD, SS
WACF-20122	SCREW, 10-24 x 0.75", PHIL TRUSS HEAD, SS
WACF-20123	SCREW, 10-24 x 0.75", T20 FLAT HEAD, SS
WACF-60103	FILTER ACCESS PANEL

10.0 Warranty and service

Wilton® warrants every product they sell against manufacturers' defects. If one of our tools needs service or repair, please contact Technical Service by calling 1-800-274-6846, 8AM to 5PM CST, Monday through Friday.

Warranty Period

The general warranty lasts for the time period specified in the literature included with your product or on the official Wilton branded website. **The WACF-3037 Wilton COLD FRONT Atomized Cooling Fan carries a ONE-YEAR warranty.**

Who is Covered

This warranty covers only the initial purchaser of the product from the date of delivery.

What is Covered

This warranty covers any defects in workmanship or materials subject to the limitations stated below. This warranty does not cover failures due directly or indirectly to misuse, abuse, negligence or accidents, normal wear-and-tear, improper repair, alterations or lack of maintenance.

How to Get Technical Support

Please contact Technical Service by calling 1-800-274-6846. **Please note that you will be asked to provide proof of initial purchase when calling.** If a product requires further inspection, the Technical Service representative will explain and assist with any additional action needed. Wilton has Authorized Service Centers located throughout the United States. For the name of an Authorized Service Center in your area call 1-800-274-6846 or use the Service Center Locator on the Wilton website.

More Information

Wilton is consistently adding new products. For complete, up-to-date product information, check with your local distributor or visit the Wilton website.

How State Law Applies

This warranty gives you specific legal rights, subject to applicable state law.

Limitations on This Warranty

WILTON LIMITS ALL IMPLIED WARRANTIES TO THE PERIOD OF THE LIMITED WARRANTY FOR EACH PRODUCT. EXCEPT AS STATED HEREIN, ANY IMPLIED WARRANTIES OF MERCHANTABILITY AND FITNESS FOR A PARTICULAR PURPOSE ARE EXCLUDED. SOME STATES DO NOT ALLOW LIMITATIONS ON HOW LONG AN IMPLIED WARRANTY LASTS, SO THE ABOVE LIMITATION MAY NOT APPLY TO YOU.

WILTON SHALL IN NO EVENT BE LIABLE FOR DEATH, INJURIES TO PERSONS OR PROPERTY, OR FOR INCIDENTAL, CONTINGENT, SPECIAL, OR CONSEQUENTIAL DAMAGES ARISING FROM THE USE OF OUR PRODUCTS. SOME STATES DO NOT ALLOW THE EXCLUSION OR LIMITATION OF INCIDENTAL OR CONSEQUENTIAL DAMAGES, SO THE ABOVE LIMITATION OR EXCLUSION MAY NOT APPLY TO YOU.

Wilton sells through distributors only. The specifications listed in Wilton printed materials and on official Wilton branded website are given as general information and are not binding. Wilton reserves the right to effect at any time, without prior notice, those alterations to parts, fittings, and accessory equipment which they may deem necessary for any reason whatsoever.

NOTE: Wilton is a division of JPW Industries, Inc. References in this document to Wilton also apply to JPW Industries, Inc., or any of its successors in interest to the Wilton brand.



427 New Sanford Road
LaVergne, Tennessee 37086
Phone: 800-274-6848
www.wiltontools.com